



Mirage 2000D

CATNO
72075



SCALE

1:72

SPAN: 127 mm
LENGTH: 202 mm
PARTS: 247 pieces

ЗБІРНА МОДЕЛЬ І ПАРТОВАНИЙ ВАРІАНТ
PLASTIC MODEL KIT LIMITED EDITION

 Mirage 2000 - французький багатоцільовий винищувач четвертого покоління, розроблений у 1970-х роках компанією Dassault. На службі з 1984 року. Був основним бойовим літаком ВПС Франції кінця XX - початку XXI століття. Зараз знаходиться на озброєнні декількох країн Азії, Європи та Латинської Америки.

Перший політ Mirage 2000D відбувся 19 лютого 1991 року, а перший політ вже серійного літака 31 березня 1993 року. Введений у склад ВПС Франції в березні 1994 року. Машина є першим французьким винищувачем, призначеним для проходження систем ППО на малих висотах і нанесення ударів по наземних цілях при будь-яких погодних умовах і в нічний час з використанням як ядерної, так і звичайної високоточної керованої авіаційної зброї з системами лазерного наведення. Інші особливості літака, що відрізняють його від попередньої модифікації, включають наявність передового бортового радіоелектронного обладнання, також системи управління польотом і прицільно-навігаційні засоби РЕБ. Всього було побудовано 86 літаків.

 The Mirage 2000 is a fourth-generation French multi-role fighter developed in the 1970s by Dassault. In service since 1984. It was the main combat aircraft of the French Air Force of the late XX - early XXI centuries. Currently in service with several countries in Asia, Europe and Latin America.

The first flight of the Mirage 2000D took place on February 19, 1991, and the first flight of the already serial aircraft on March 31, 1993. Introduced into the French Air Force in March 1994. The aircraft is the first French fighter designed to pass air defense systems at low altitudes and strike ground targets in all weather conditions and at night using both nuclear and conventional high-precision guided aircraft weapons with laser guidance systems. Other features of the aircraft that distinguish it from the previous modification include the presence of advanced on-board electronic equipment, as well as flight control systems and EW sighting and navigation means. A total of 86 aircraft were built.

НЕОБХІДНІ ФАРБИ \ REQUIRED PAINTS

A Forest Green Mr.Color C309 AK RC027	B Dark Gull Grey Mr.Color C317 AK RC247	C Pale Yellow Mr.Color C313 AK RC018	D White Mr.Color C62 AK RC004	E Flat Black Mr.Color C33 AK RC001	F Olive Drab Mr.Color C012 AK RC023	G Dark Olive Drab Mr.Color C304 AK RC026	H Steel Mr.Met.Color MC213 AK Xtr.Met. - AK476
I Burnt Metal Mr.Color C61 AK Xtr.Met. - AK484	J Aluminium Mr.Met.Color MC218 AK Xtr.Met. - AK479	K Chrom Silver Mr.Met.Color MC211 AK Xtr.Met. - AK477	L Rubber/Tires Mr.Color C137 AK RC022	M Light Grey Mr.Color C338 AK RC253	N Orange Yellow Mr.Color C113 AK RC267	O Red Mr.Color C47 AK RC503	P Khaki Mr.Color C55 AK RC096
Q Green Mr.Color C303 AK 2303	R Blue Mr.Color C110 AK RC011						

УМОВНІ СИМВОЛИ \ USED SYMBOLS

1 ЕТАПИ ЗБИРАННЯ / STAGES OF ASSEMBLY **A1** НОМЕР ДЕТАЛІ / PART NUMBER **1** ОКРЕМІ ДЕТАЛІ / SEPARATE DETAILS **1** НАКЛІЙТИ ДЕКАЛІ / APPLY DECALS **1** НАКЛІЙТИ МАСКУ / APPLY THE ADHESIVE MASK **?** НА ВИБІР / OPTIONAL

A ВАРИАНТИ ДЛЯ ЗБИРАННЯ / VARIANTS OF ASSEMBLY **S** КЛЕЙТИ НА СУПЕРКЛЕЙ / GLUE ON "SUPER GLUE" **X** НЕ КЛЕЙТИ / DON'T GLUE **○** ЗРОБИТИ ОТВІР / MAKE A HOLE **△** ВІДРІЗАТИ НОЖЕМ / DETACH WITH KNIFE **A** ФАРБУВАТИ / TO PAINT

Модель вироблена за технологією «short run»
і призначена для досвідчених моделістів

This model is produced using short run technology,
designed for experienced modelers



Комплектність / Complete Set

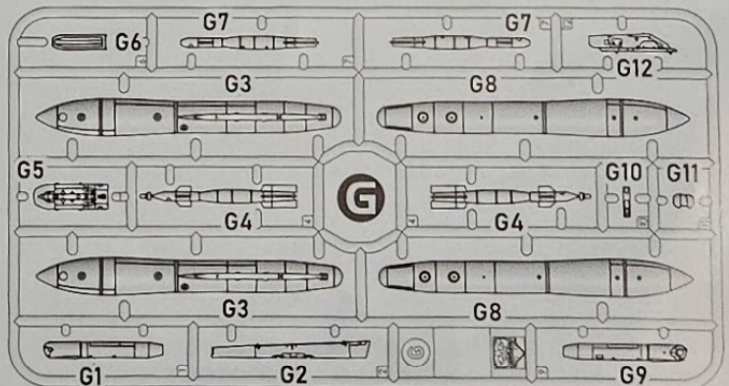
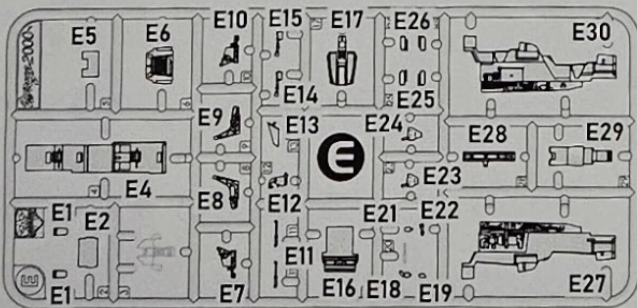
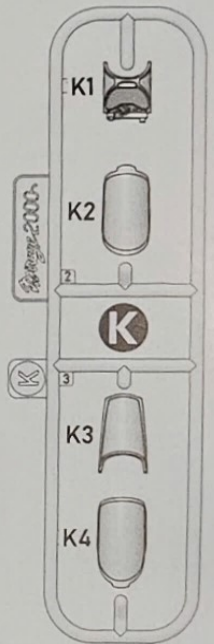
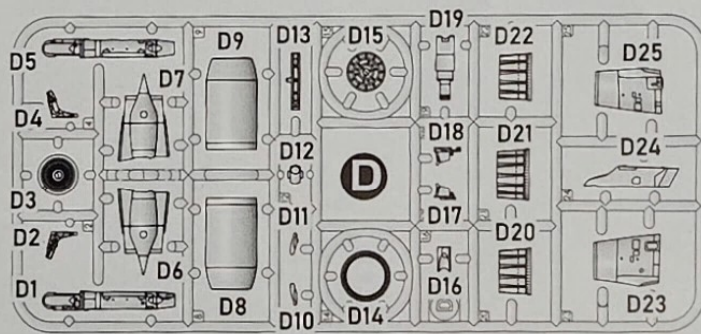
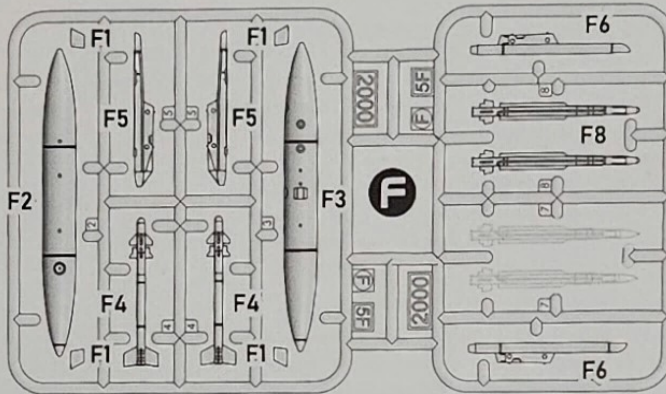
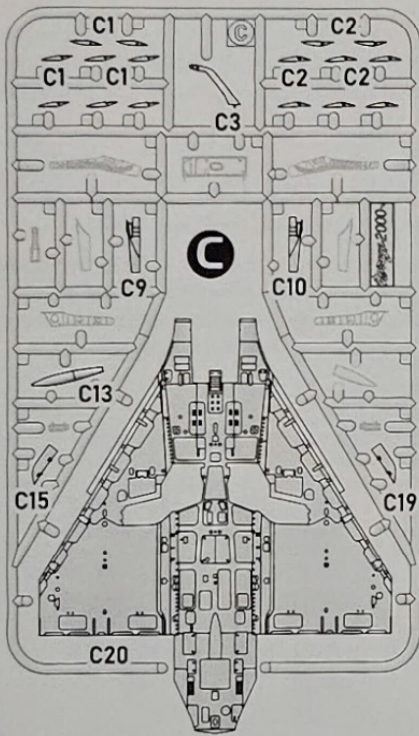
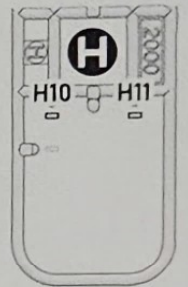
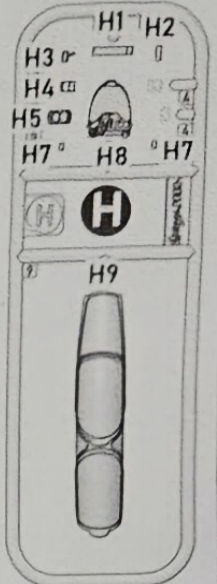
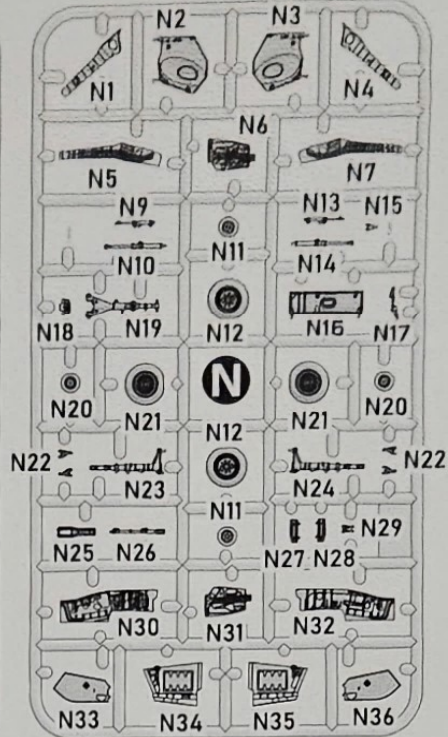
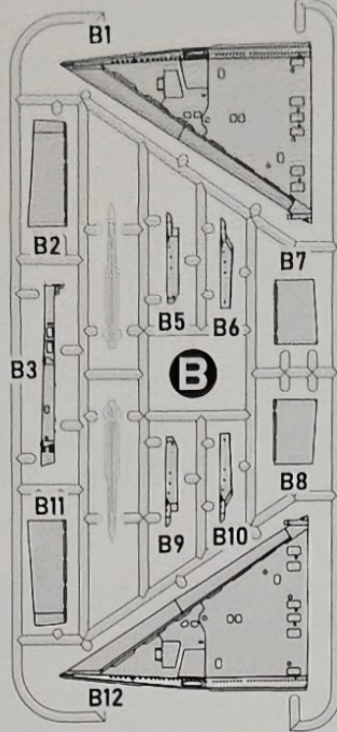
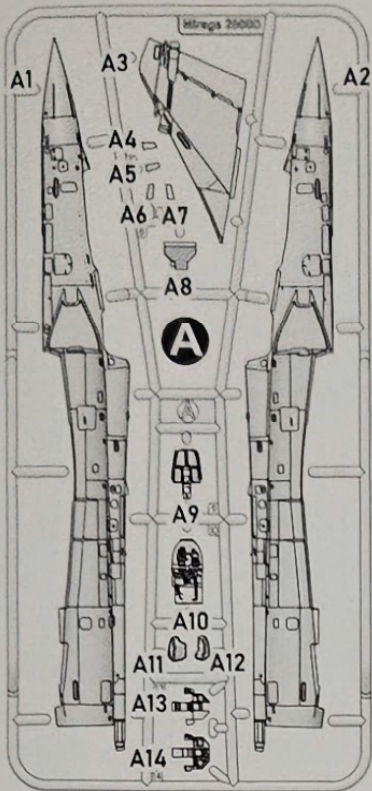



Комплектність / Complete Set

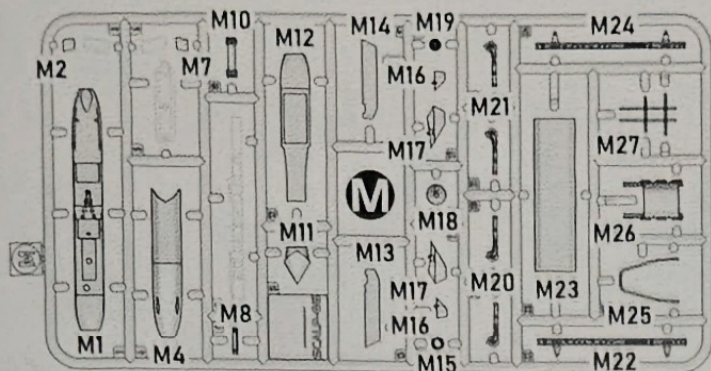

ОДНА ДЕКАЛЬ ДЛЯ ТРЬОХ ВАРІАНТІВ ЗАБАРВЛЕННЯ
ONE DECAL FOR THREE VERSIONS OF COLOURING

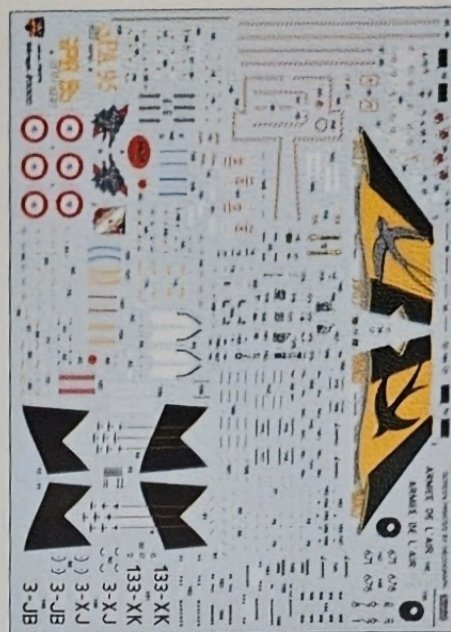

2

ЛИСТ ФОТОЕТЧУ
PHOTO-ETCHED SHEET

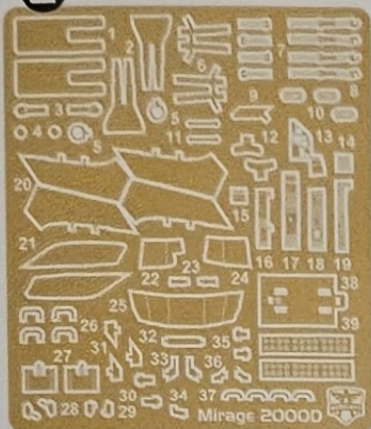

МАСКИ ДЛЯ ФАРБУВАННЯ
MASKS FOR PAINTING

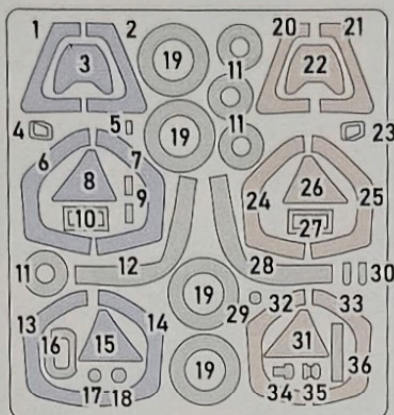

ЗОВНІ
OUTSIDE

ВСЕРЕДИНИ
INSIDE

Схема збирання / The scheme of assembly

1

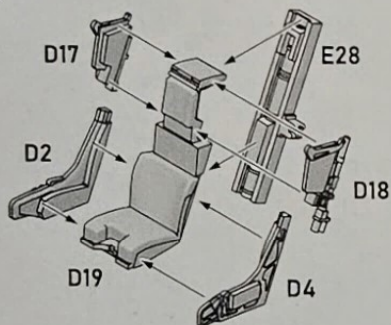

2

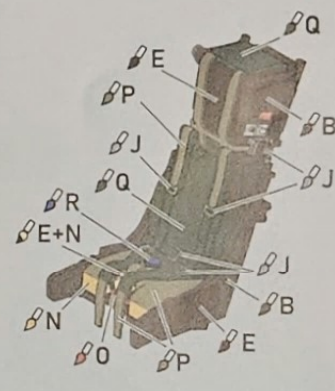
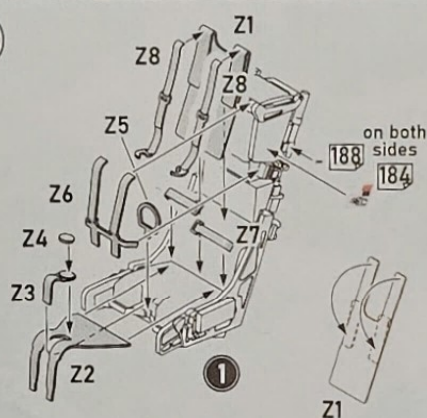

3

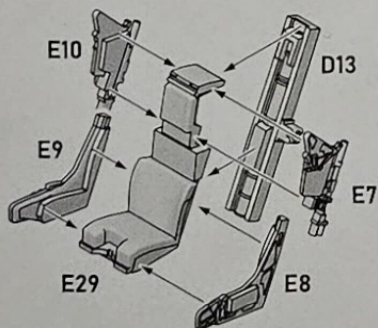

4





Схема збирання / The scheme of assembly



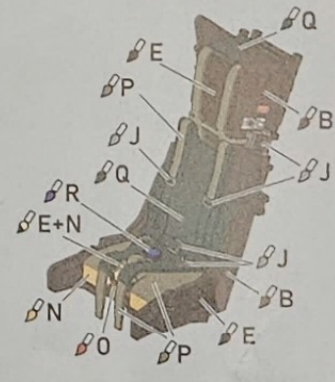
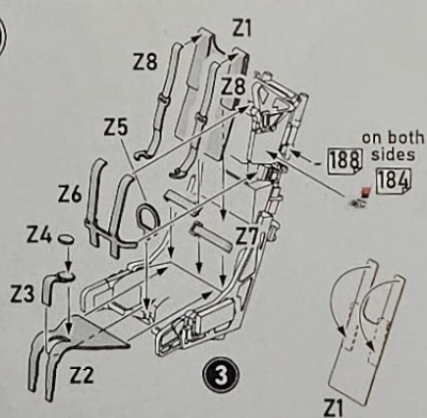

Схема збирання / The scheme of assembly



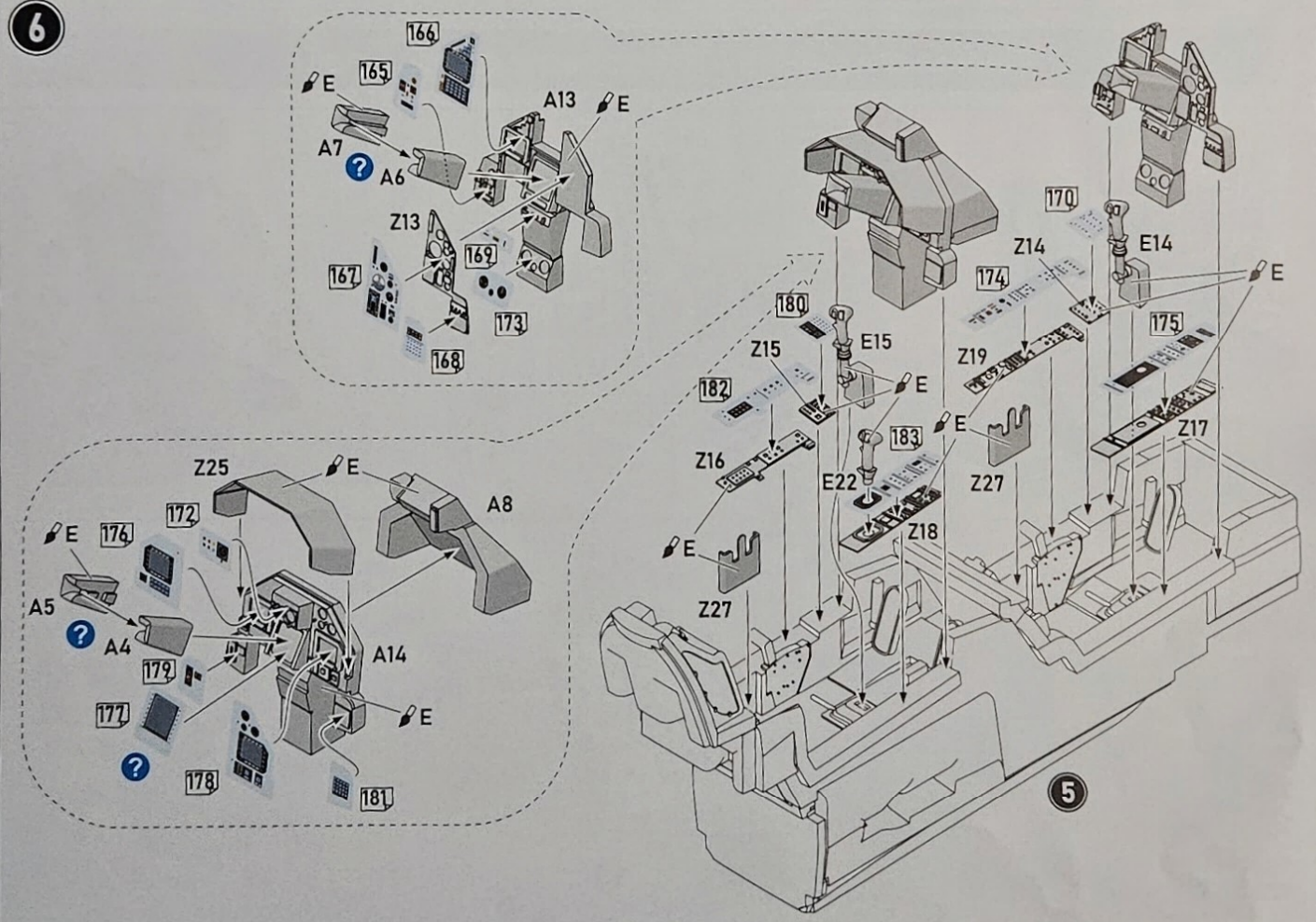
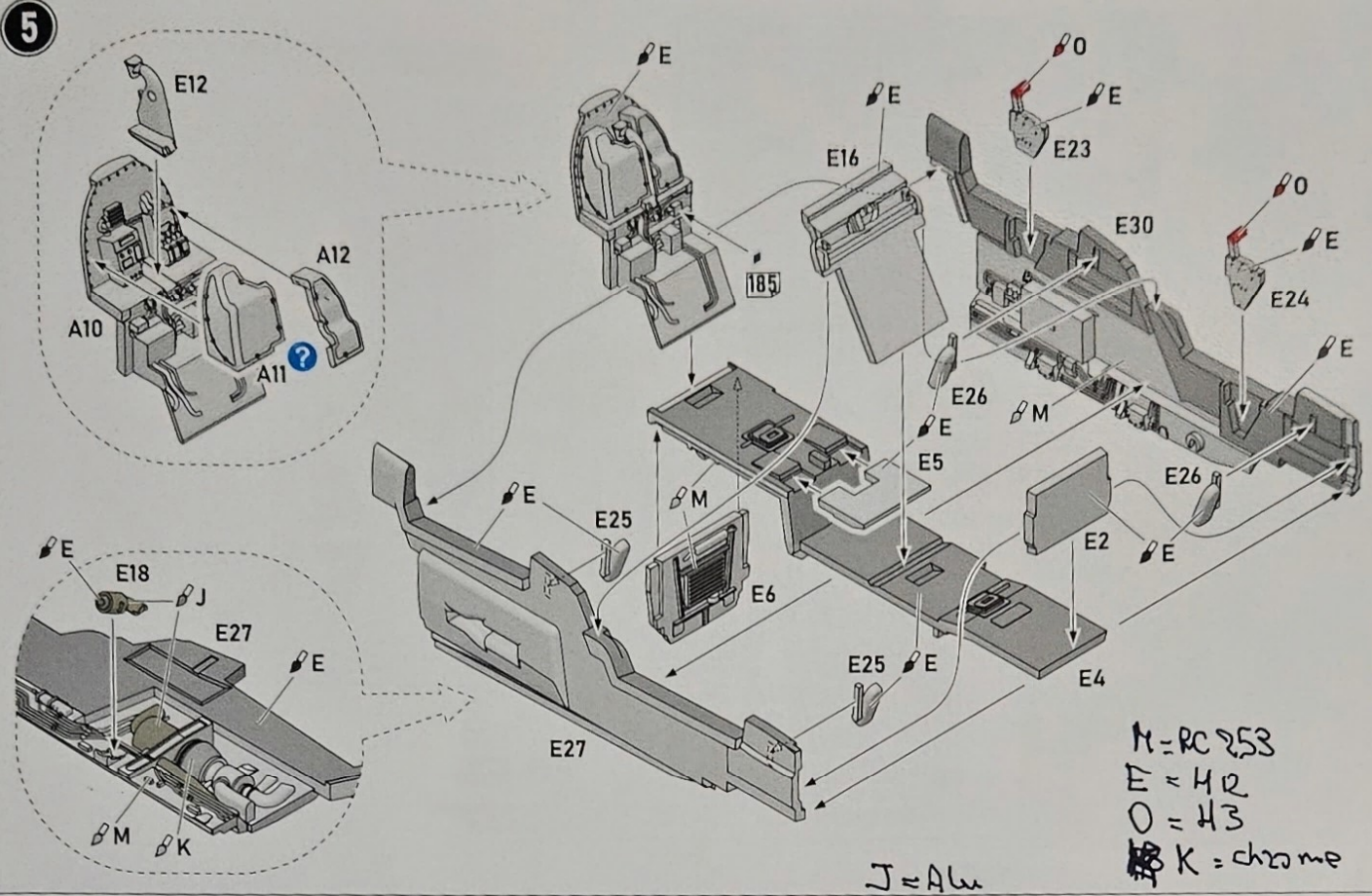

Схема збирання / The scheme of assembly



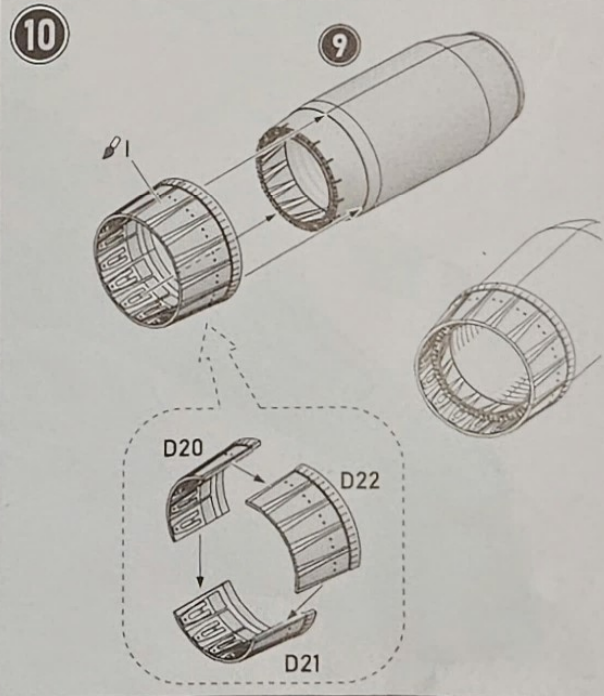
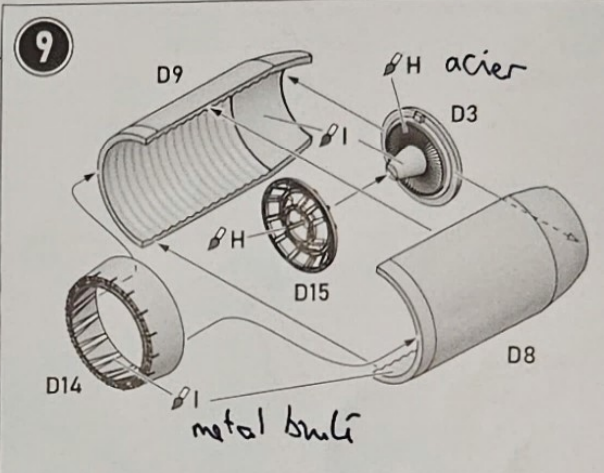
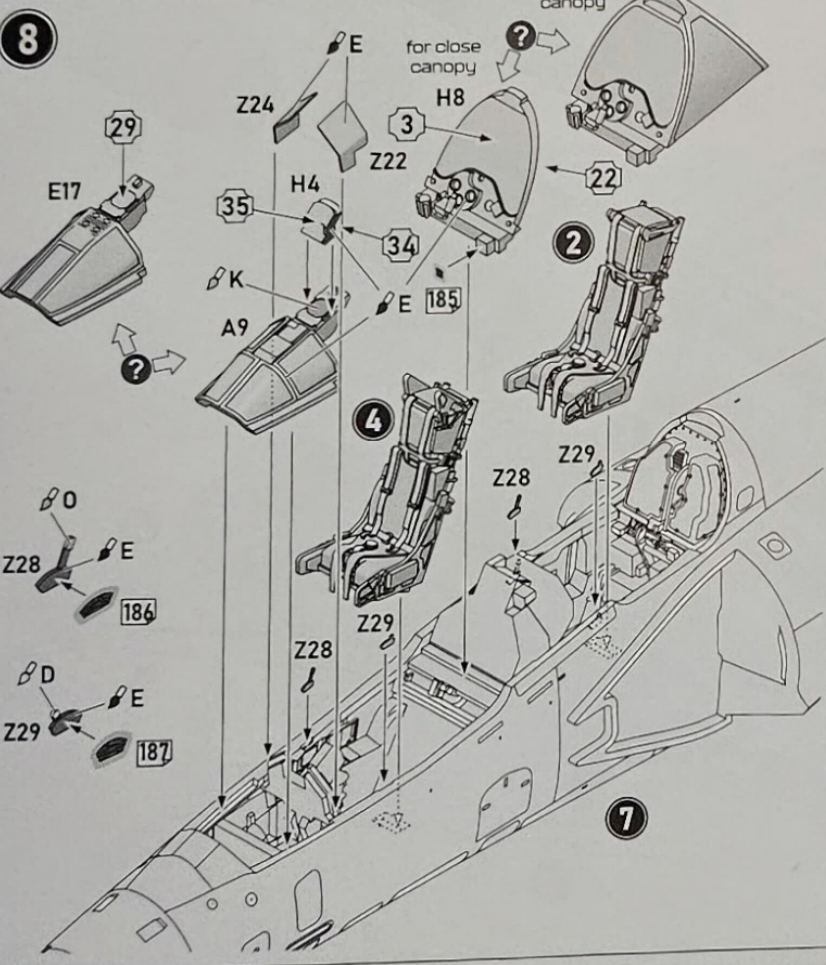
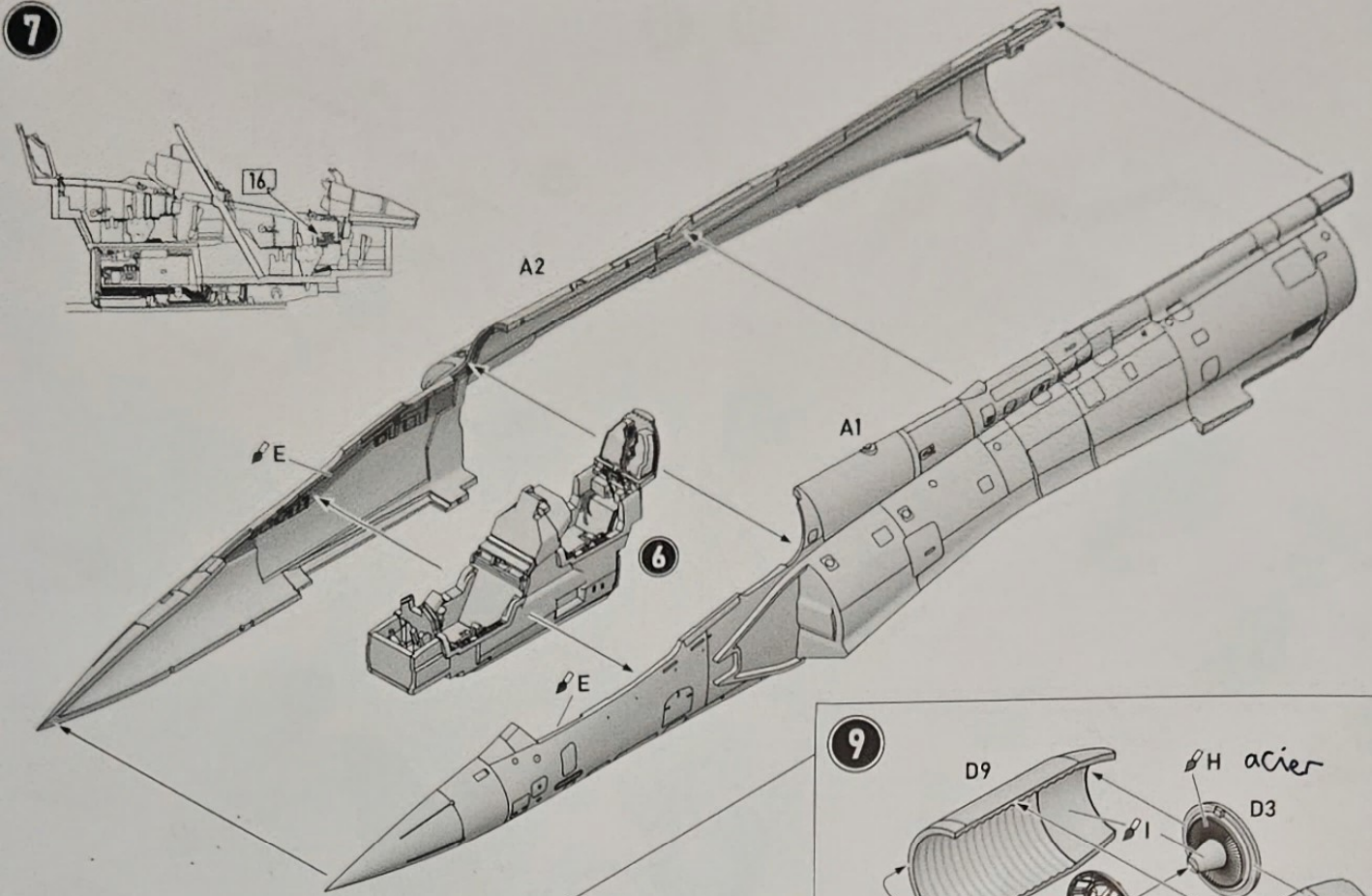

Схема збирання / The scheme of assembly



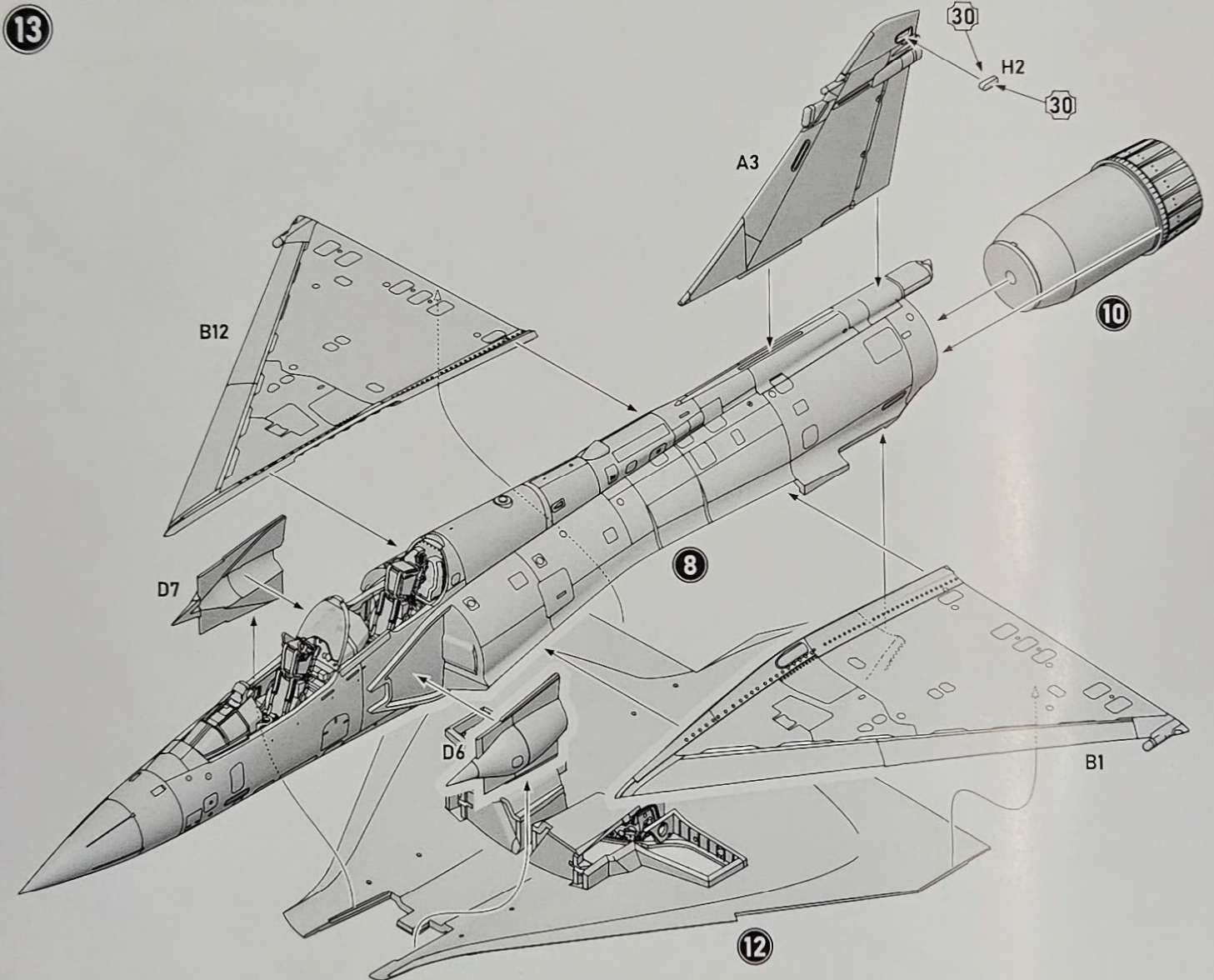
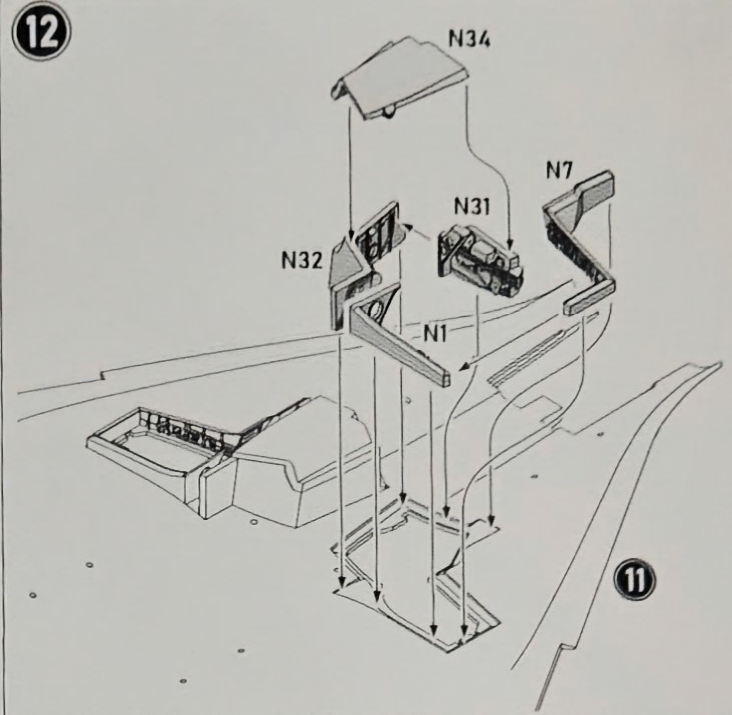
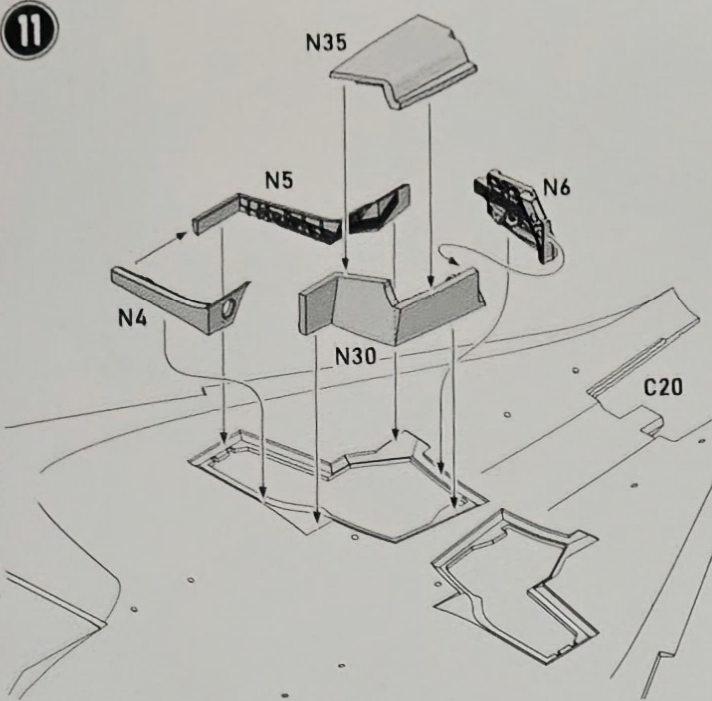

Схема збирання / The scheme of assembly

22

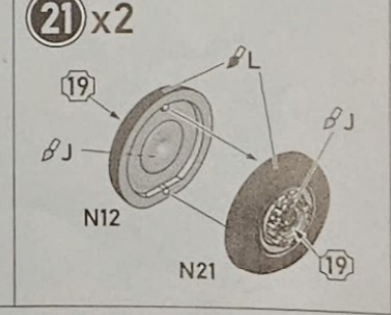
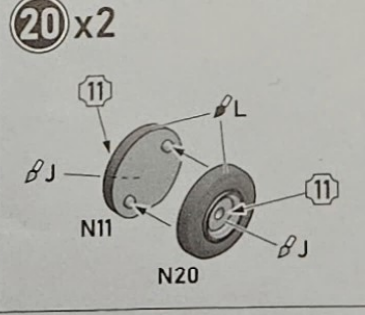
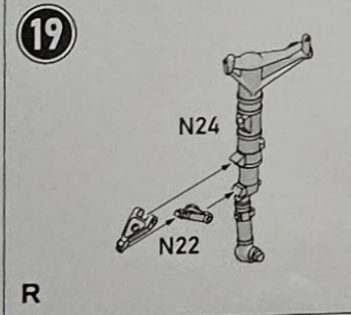
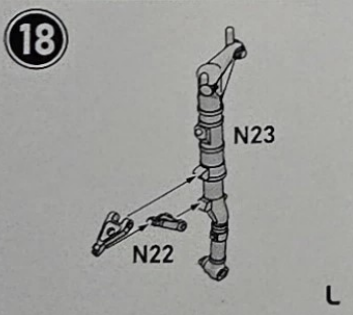
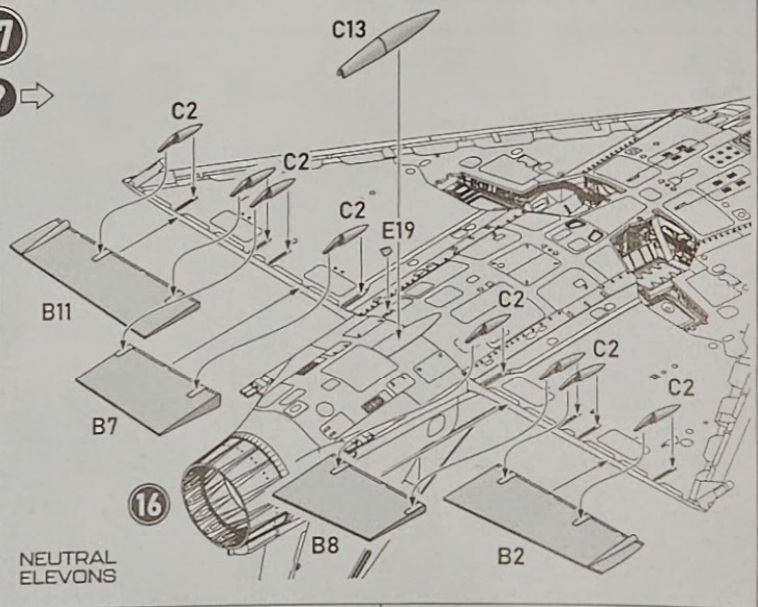
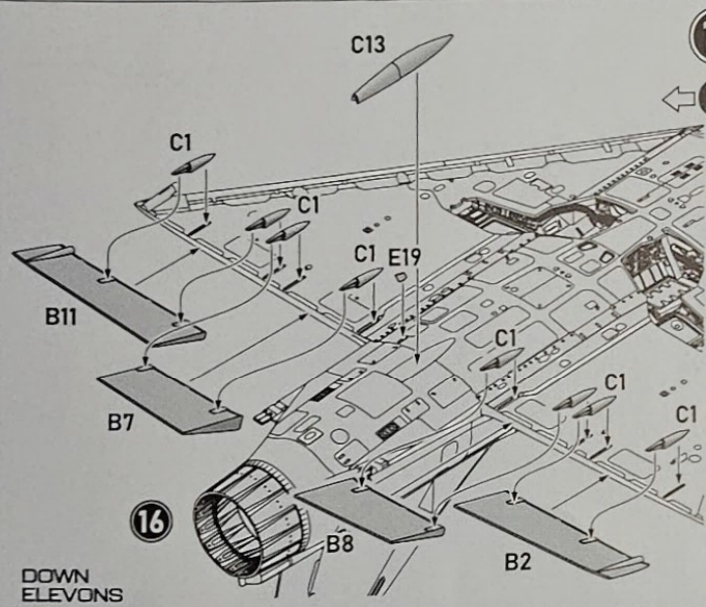
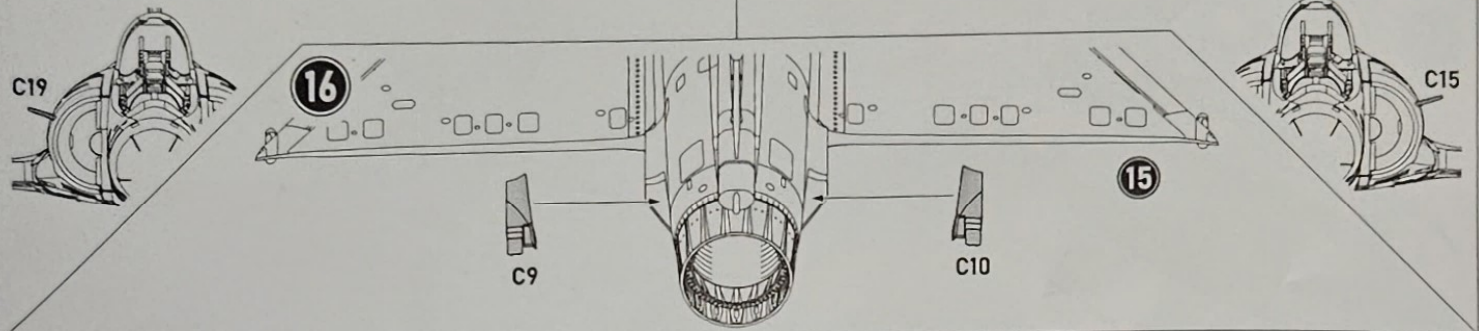
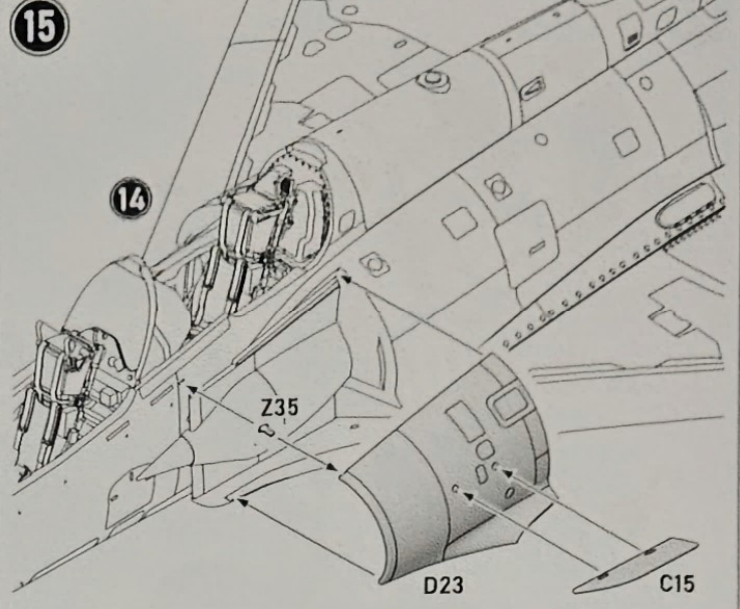
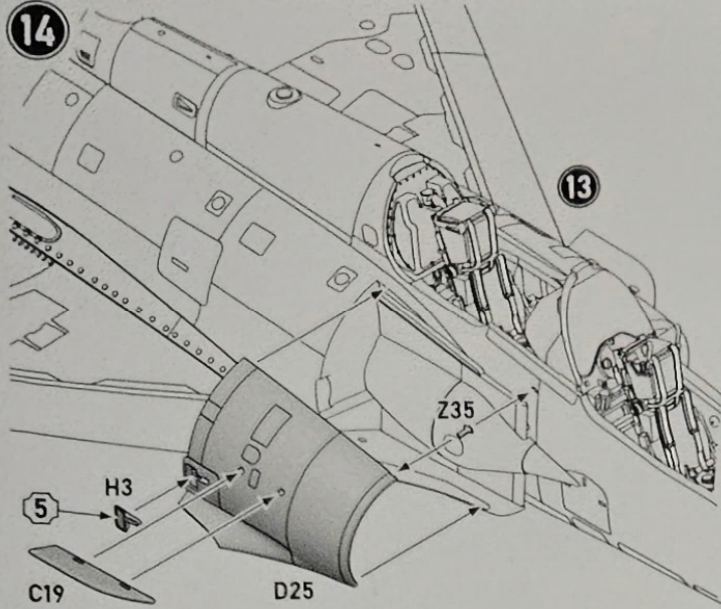
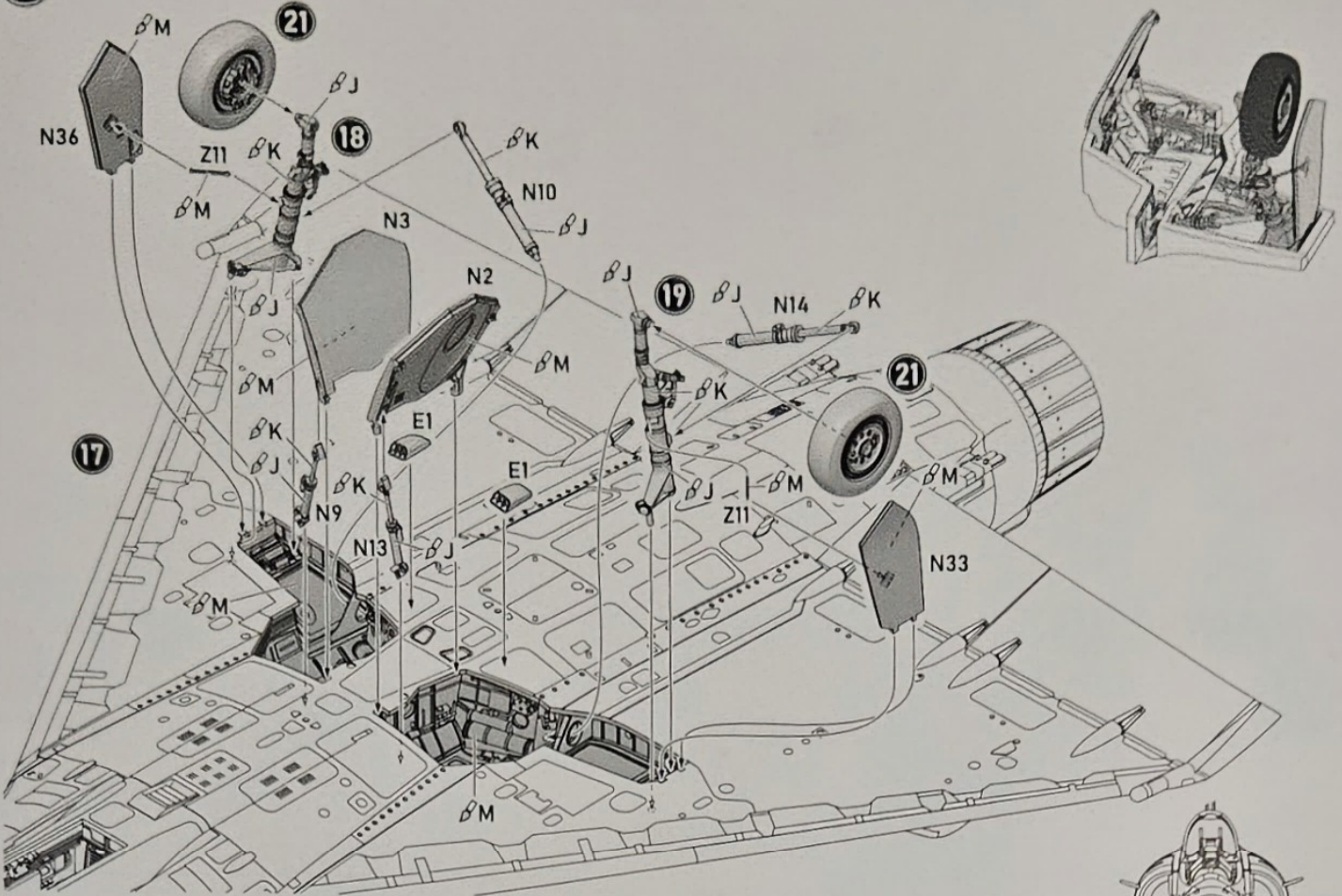

23

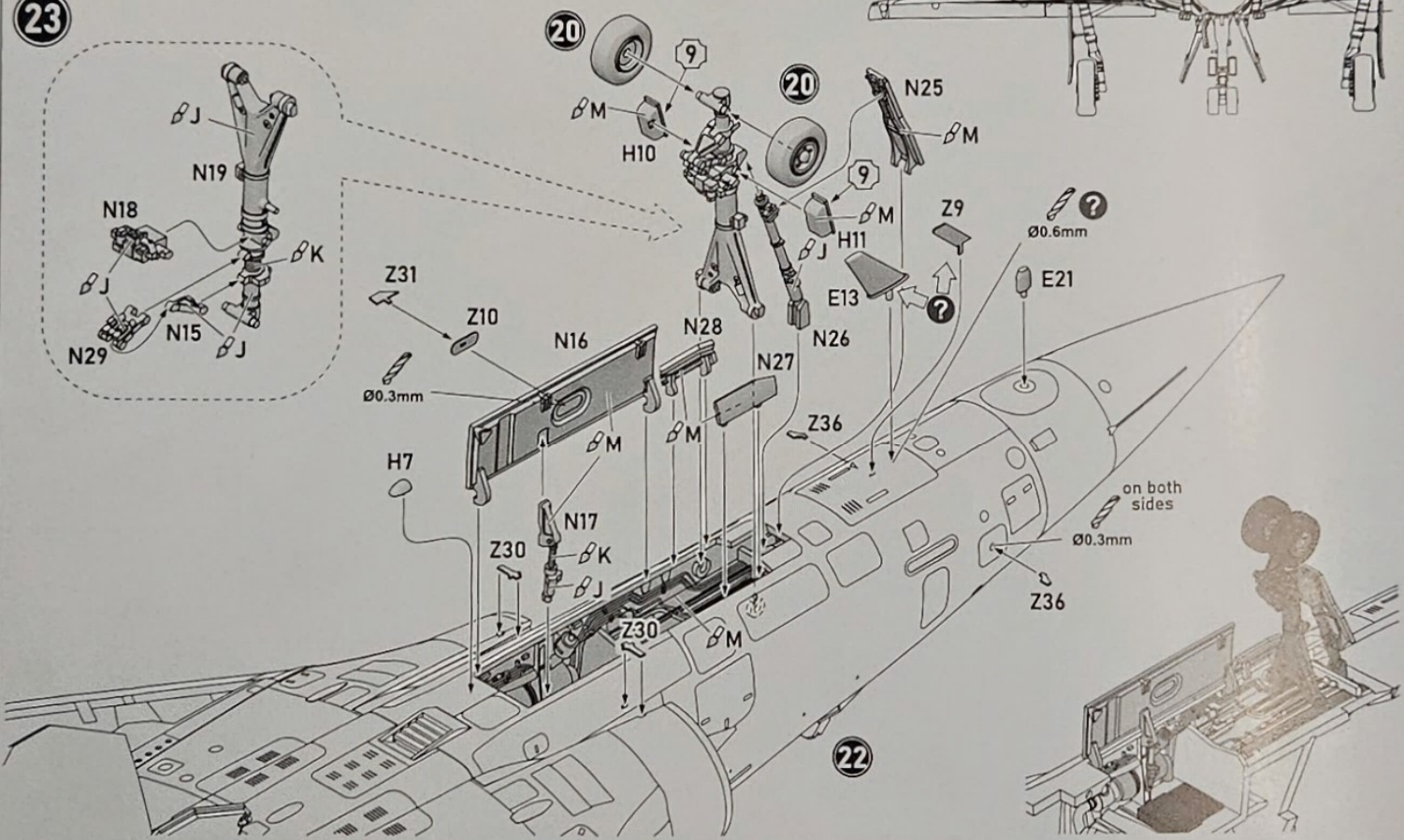

24

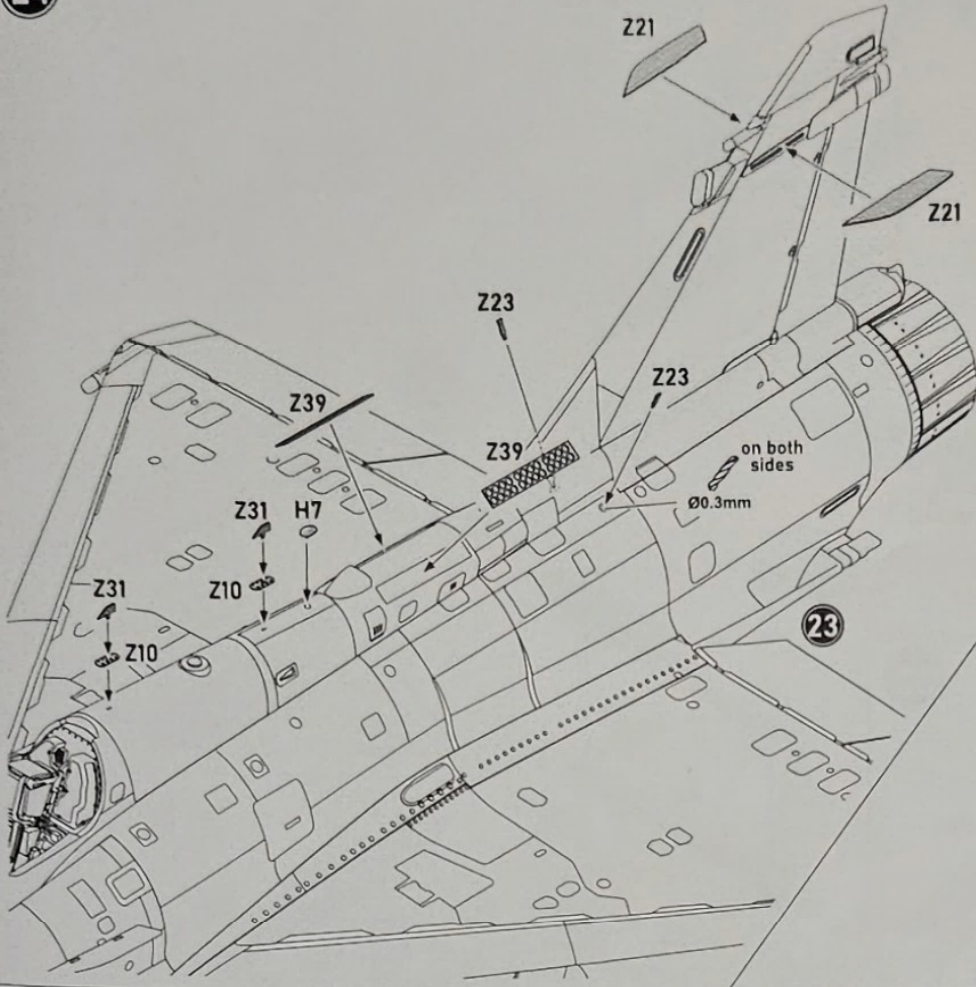

25

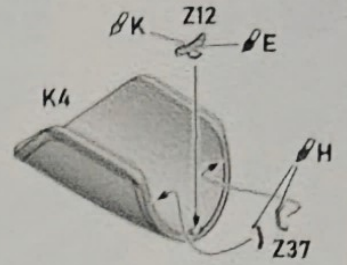

26

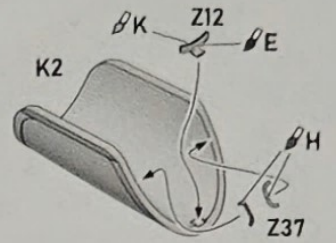

27

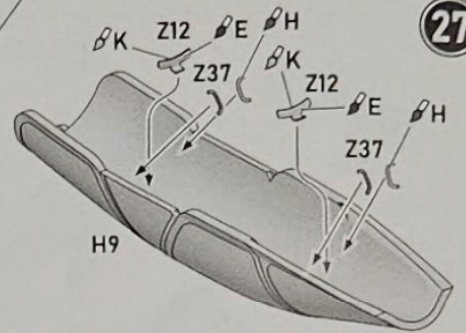

28





Схема збирання / The scheme of assembly

29 x2

RP-54I/542
2000L
Fuel Tank

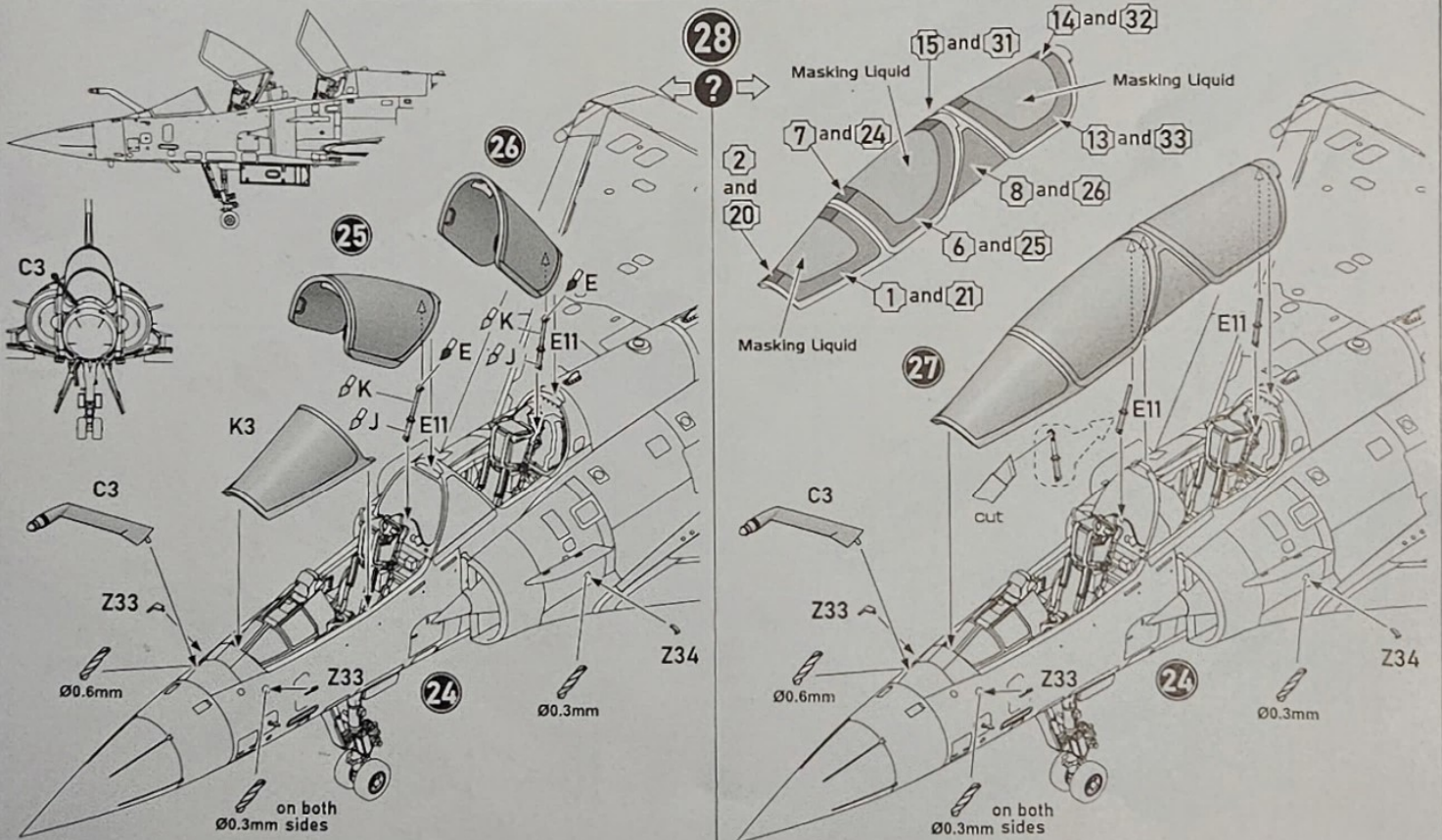
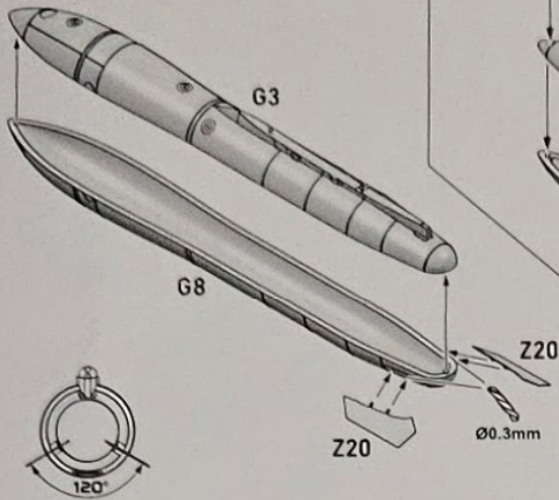

30

RP-522 1300L
Fuel Tank

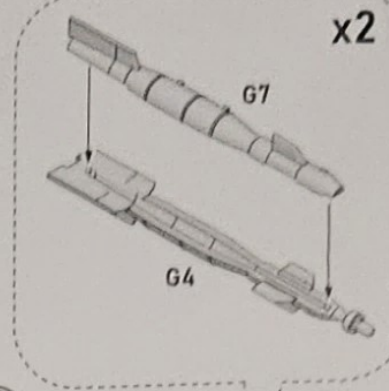
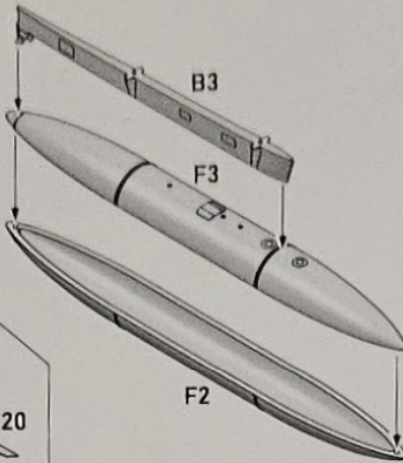

31

GBU-12
Laser Guided
Aerial Bomb

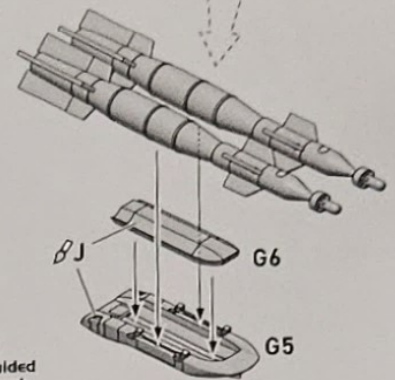

32 x2

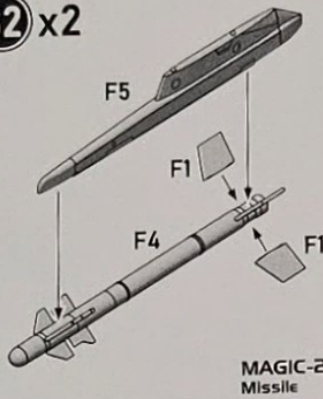

MAGIC-2
Missile

33

PDLCTS
Pod

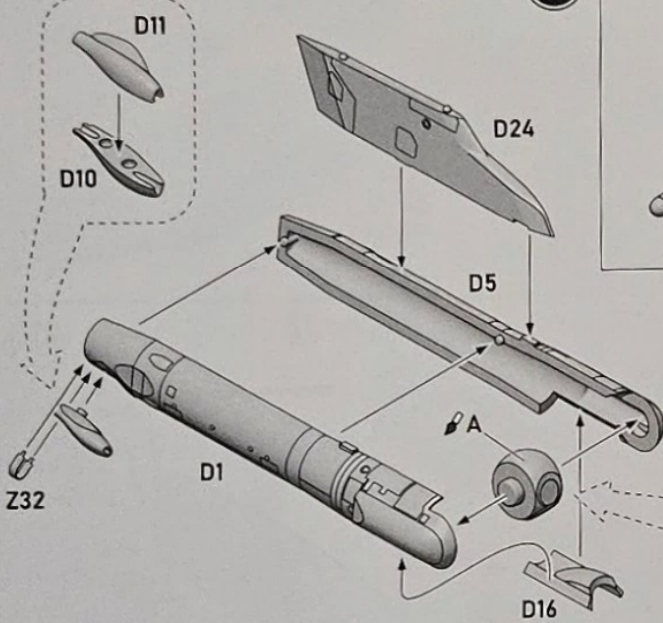

34

ATLIS II
Pod

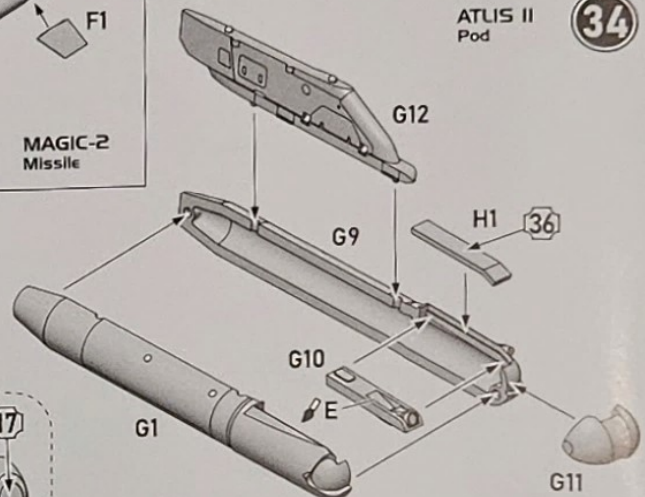

35

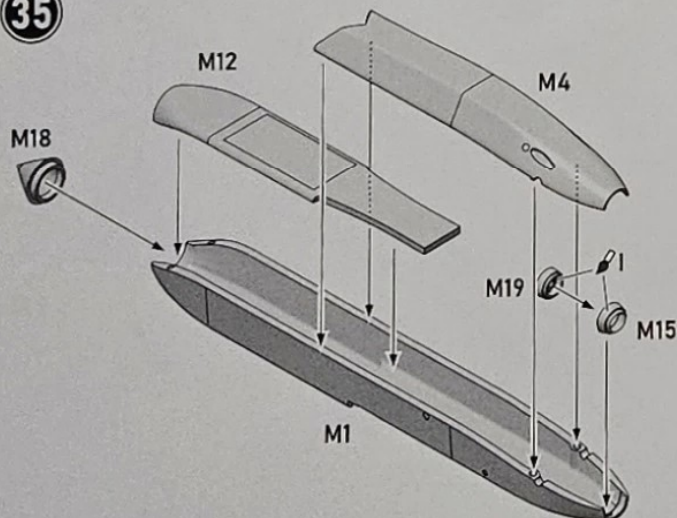

36

SCALP-EG
Cruise Missile





Схема збирання / The scheme of assembly

37

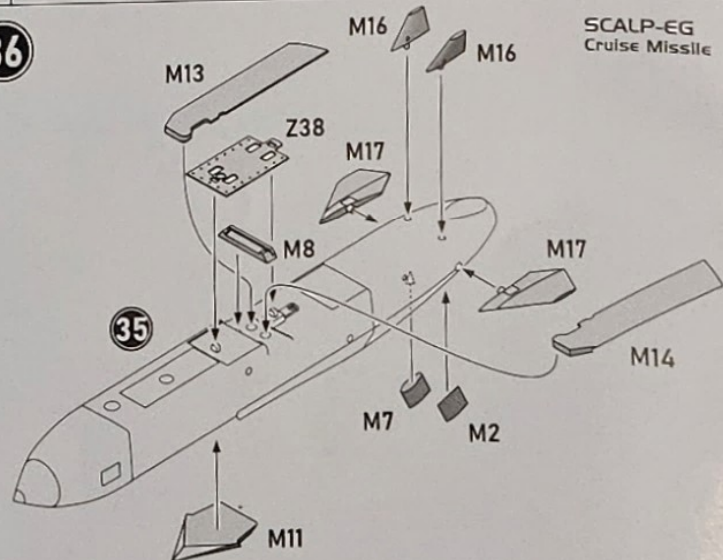
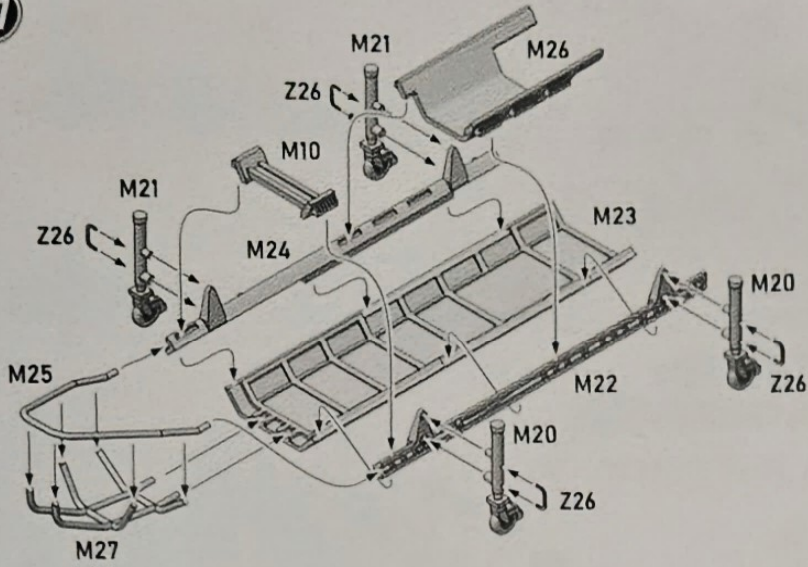

38

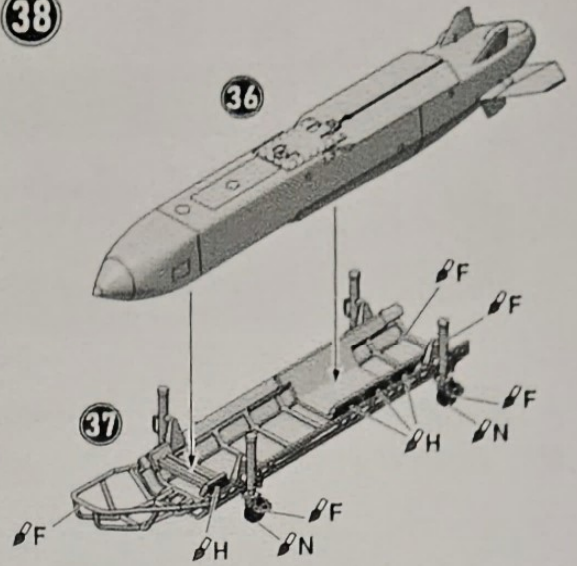

39

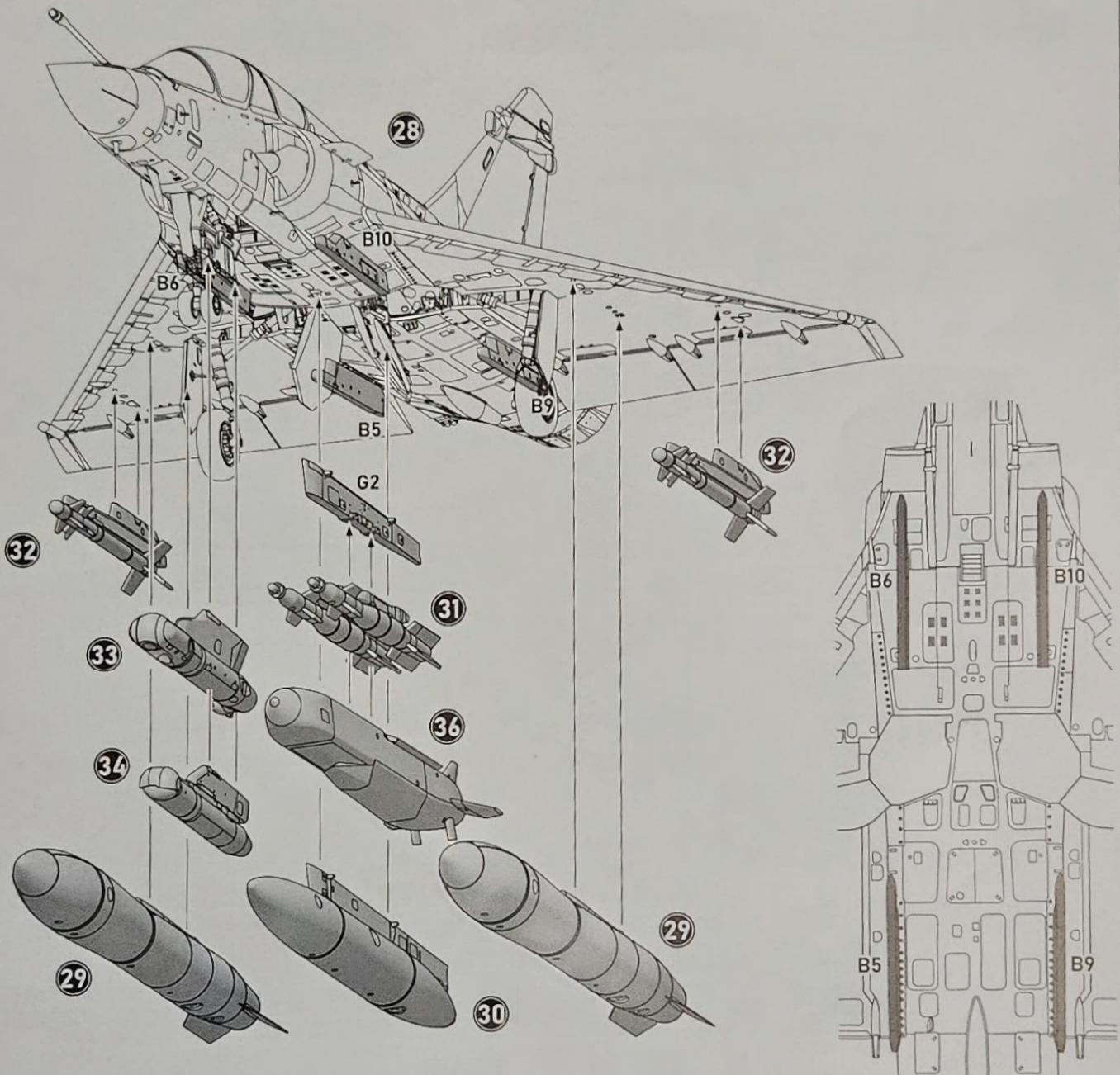

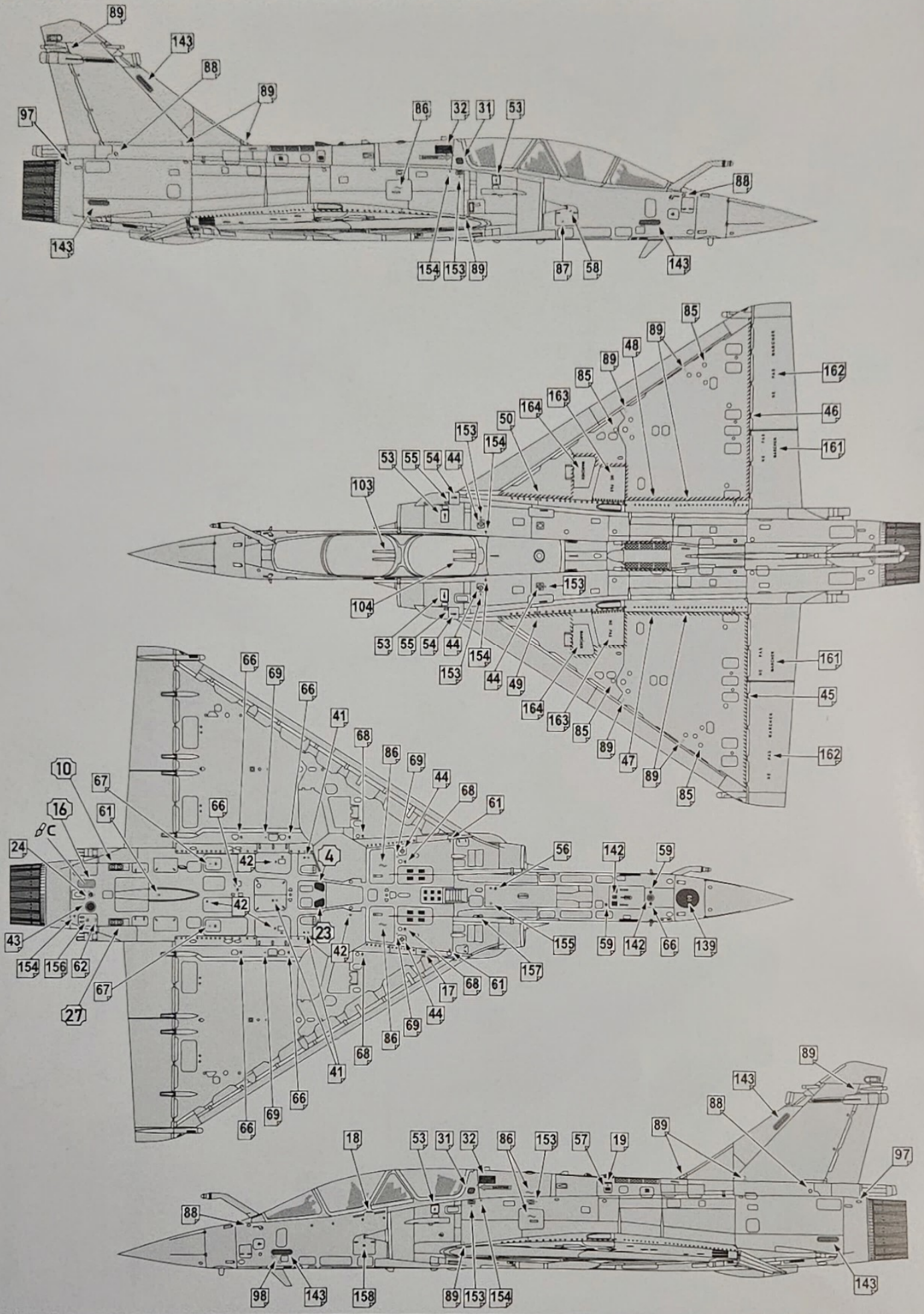



Технічні нагнучу / Technical stencils

SCALP-EG

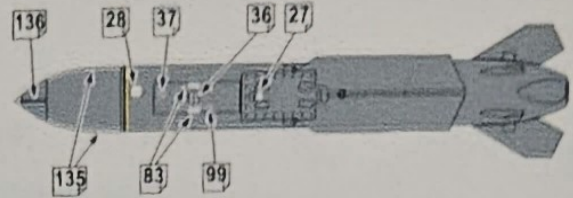
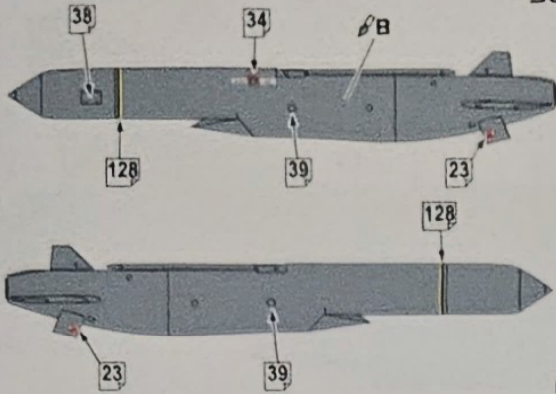

GBU-12



ATLIS II

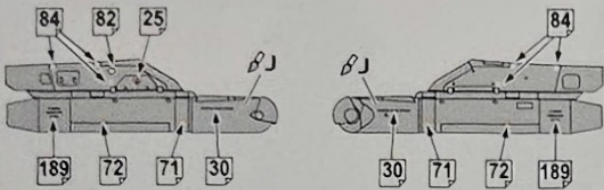

PDLCTS

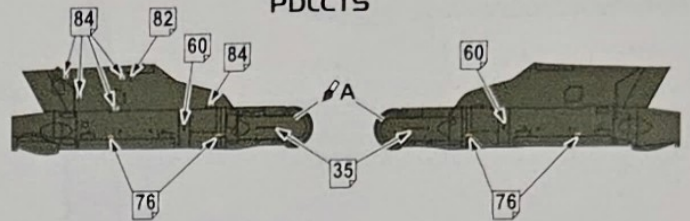

MAGIC-2

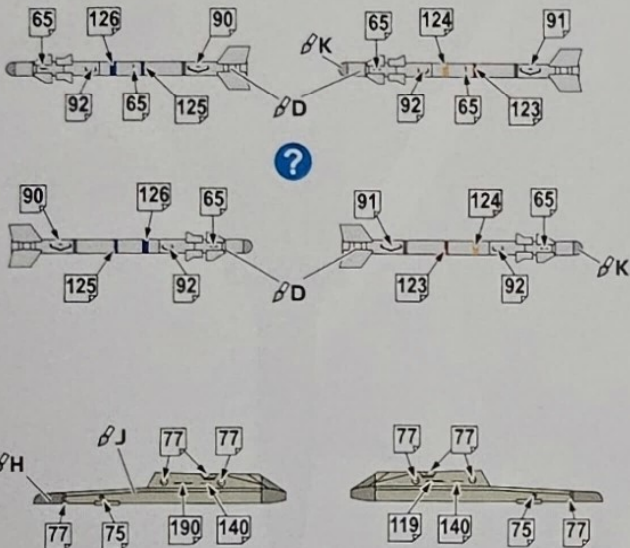

RP-54I/542 2000L

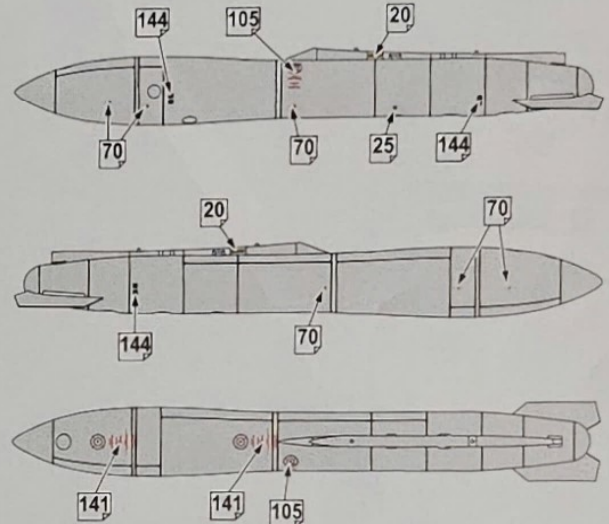

RP-522 1300L

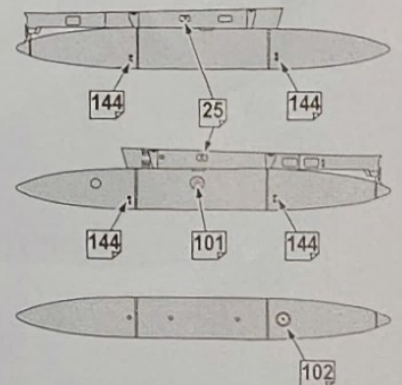
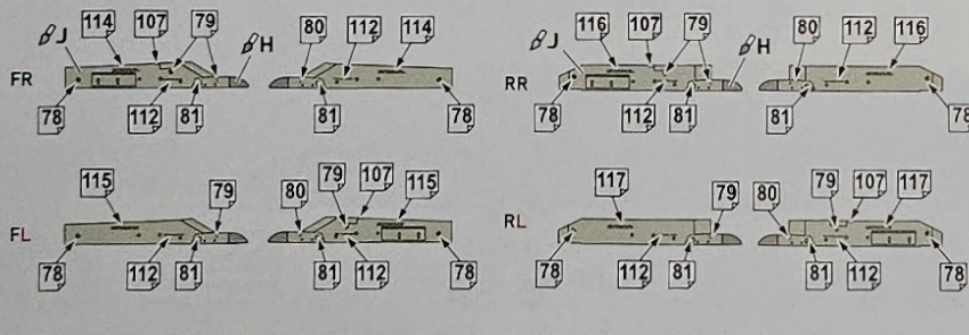

A Forest Green
Mr.Color C309
AK RC027

B Dark Gull Grey
Mr.Color C317
AK RC247

D White
Mr.Color C62
AK RC004

G Dark Olive Drab
Mr.Color C304
AK RC026

H Steel
Mr.Met.Color MC213
AK Xtr.Met.- AK476

J Aluminium
Mr.Met.Color MC218
AK Xtr.Met.- AK479

K Chrom Silver
Mr.Met.Color MC211
AK Xtr.Met.- AK477



Схема розфарбування / Painting scheme

1 Mirage 2000D N°671 133-XK, EC 3-3, Souda Bay AB, 2011

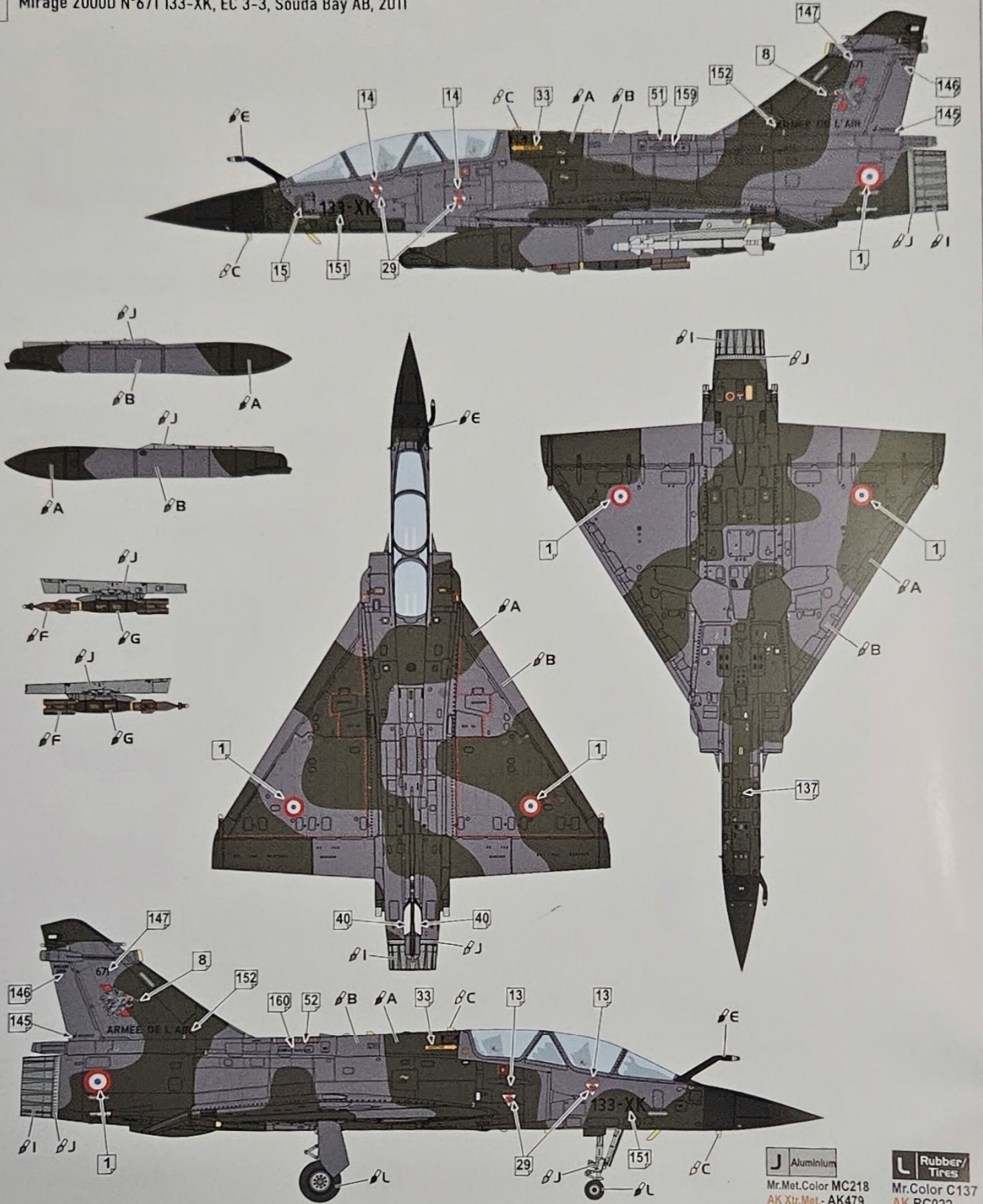

A Forest Green
Mr.Color C309
AK RC027

B Dark Gull Grey
Mr.Color C317
AK RC247

C Pale Yellow
Mr.Color C313
AK RC018

E Flat Black
Mr.Color C33
AK RC001

F Olive Drab
Mr.Color C012
AK RC023

G Dark Olive Drab
Mr.Color C304
AK RC026

H Steel
Mr.Met.Color MC213
AK Xtr.Met.- AK476

I Burnt Metal
Mr.Color C61
AK Xtr.Met.- AK484

J Aluminium
Mr.Met.Color MC218
AK Xtr.Met.- AK479

L Rubber/Tires
Mr.Color C137
AK RC022



Схема розфарбування / Painting scheme

2 Mirage 2000D N°678 3-JB, EC 02.003 Champagne



A Forest Green
Mr.Color C309
AK RC027

B Dark Gull Grey
Mr.Color C317
AK RC247

C Pale Yellow
Mr.Color C313
AK RC018

E Flat Black
Mr.Color C33
AK RC001

H Steel
Mr.Met.Color MC213
AK Xtr.Met.- AK476

I Burnt Metal
Mr.Color C61
AK Xtr.Met.- AK484

J Aluminium
Mr.Met.Color MC218
AK Xtr.Met.- AK479

L Rubber/Tires
Mr.Color C137
AK RC022



Схема розфарбування / Painting scheme

3 Mirage 2000D N°602 3-XJ. CN 393. Spa 95. EC 13 Navarre



A Forest Green
Mr.Color C309
AK RC027

B Dark Gull Grey
Mr.Color C317
AK RC247

C Pale Yellow
Mr.Color C313
AK RC018

E Flat Black
Mr.Color C33
AK RC001

H Steel
Mr.Met.Color MC213
AK Xtr.Met.- AK476

I Burnt Metal
Mr.Color C61
AK Xtr.Met.- AK484

J Aluminium
Mr.Met.Color MC218
AK Xtr.Met.- AK479

N Orange Yellow
Mr.Color C113
AK RC267

L Rubber/Tires
Mr.Color C137
AK RC022