

# 35 K04

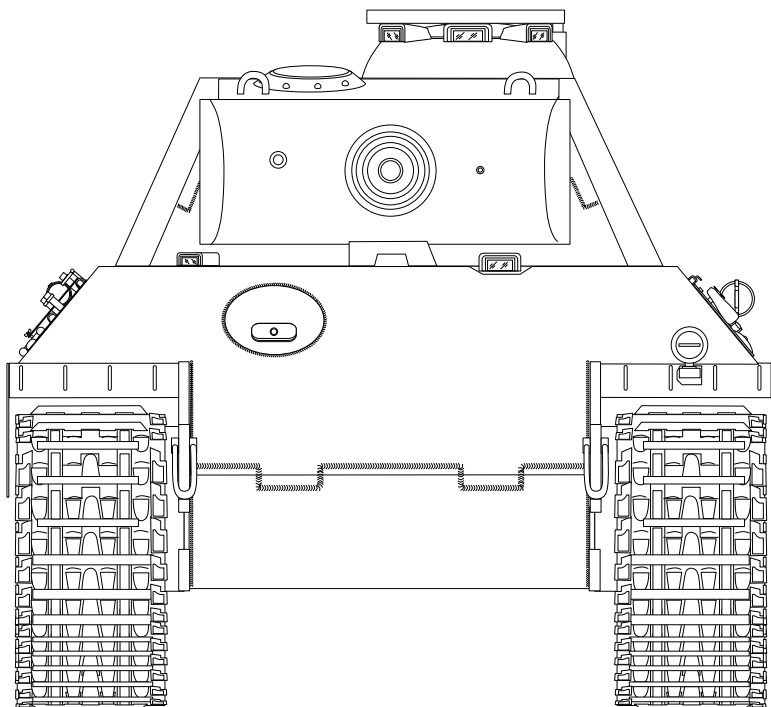

## EXCLUSIVE EDITION

### UPGRADE SET FOR DRAGON 1/35 MODEL



## GERMAN MEDIUM TANK PANTHER G

Pz.Kpfw. V (Sd.Kfz. 181) - Ausf. G

*Niemiecki średni czołg Sd.Kfz. 181 "Panther G"*

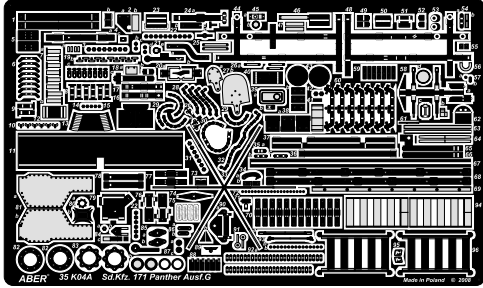
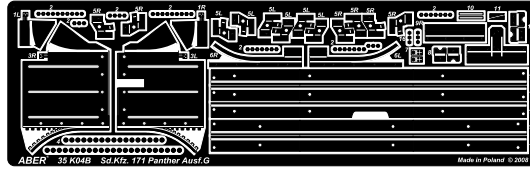
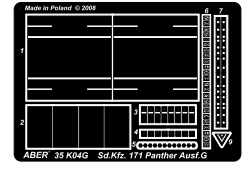
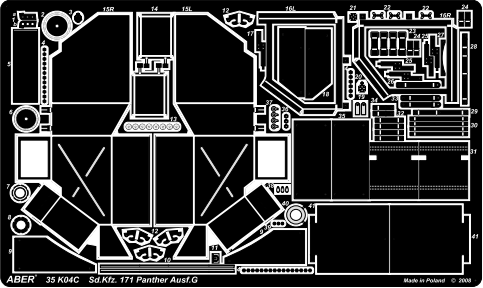
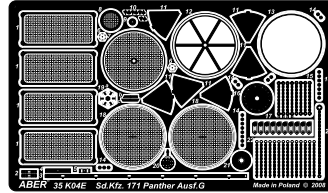
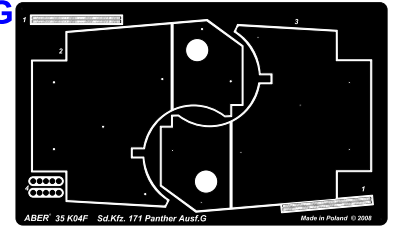
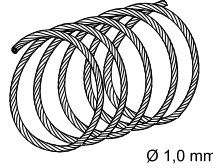
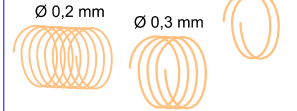
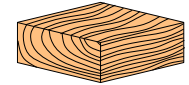
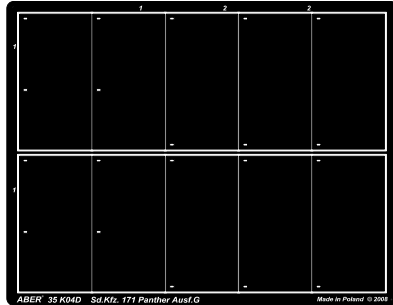
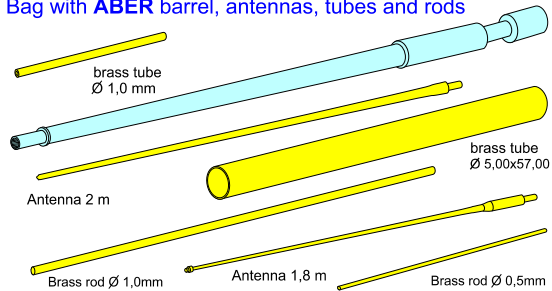
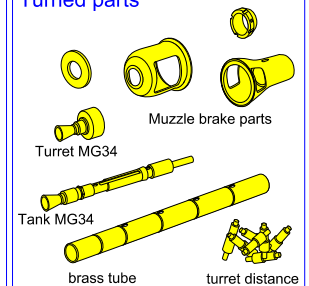
**A****C****F****B****E****G****Bag with cable****Bag with wires****Bag with wood chock****D****Bag with ABER barrel, antennas, tubes and rods****Turned parts**

## MOST IMPORTANT BIBLIGRAPHY:

- 1) Sd.Kfz.171; Pz.Kpfw.V PANTHER - Waldemar Trojca - "Trojca" ©2003
- 2) Achtung Panzer No.4 - PANTHER, Jagdpanther & Brummbär by Mitsuru Bitoh - Dai Nippon Kaiga Co.,Ltd. ©1994
- 3) GROUND POWER No.024, 079 - Delta Publishing Co.,Ltd. ©1996, ©2000
- 4) Militärfahrzeuge Band 9; Der Panzer-Kampfwagen Panther und Seine Abarten - Walter J. Spielberger - Motorbuch ©1994
- 5) Panther in Detail - B. Culver & U. Feist - Ryton Publications ©1998
- 6) Panzer Tracts No.5 - Thomas L. Jentz & Hilary Louis Doyle
- 7) New Vanguard 22: PANTHER VARIANTS 1942-1945 - Osprey Military ©1997

Thank you for purchase our set **35 K04**.

Read carefully this instruction.

We advise that better method to join metal to metal parts is soldering.

Cement metal parts to plastic with good cyanoacryl or epoxy glue.

### WARNING

Any unauthorized copying, producing and reproducing of ABER company products, or any part thereof, is strictly prohibited and any such action establishes liability for a civil action and may give rise to criminal prosecution.

### OSTRZEŻENIE

Jakiegokolwiek kopiowanie, produkowanie i reprodukcja wyrobów firmy ABER bez zezwolenia, w całości lub części jest surowo zabronione. Powyższe działania powodują powstanie odpowiedzialności cywilnej oraz mogą spowodować wszczęcie postępowania karnego.

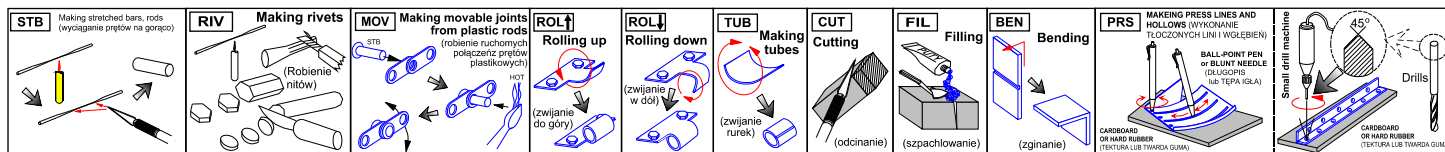

## TOOLS RECOMMENDED

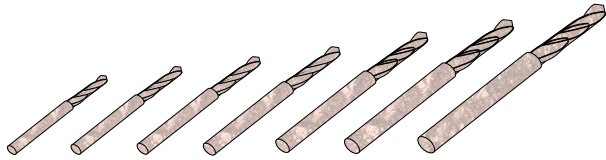

Drills from  $\varnothing$  0,4 to 1,5 mm



Assortment of cutting wheels and mills

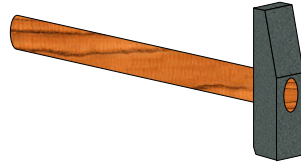

Light weight hammer

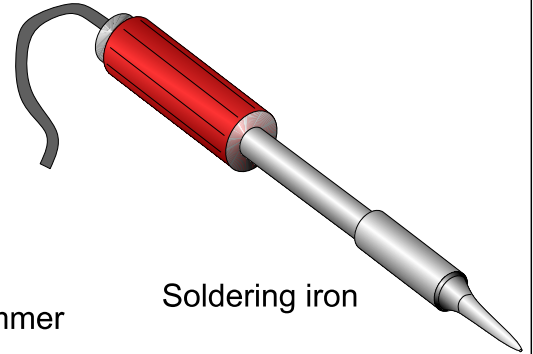

Soldering iron

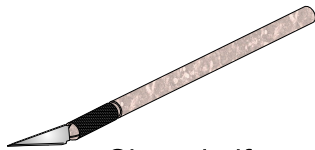

Sharp knife

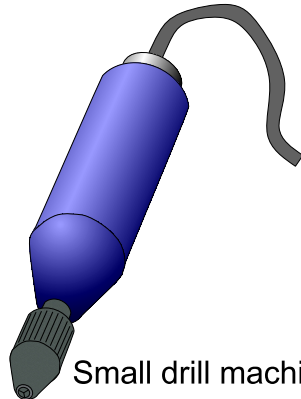

Small drill machine



Bending tool  
PG01 or PG02



Soldering flux



Solder

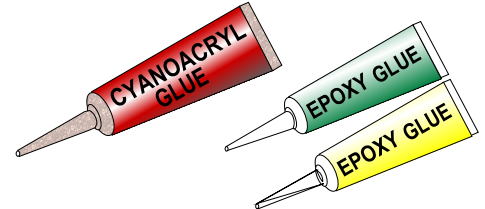

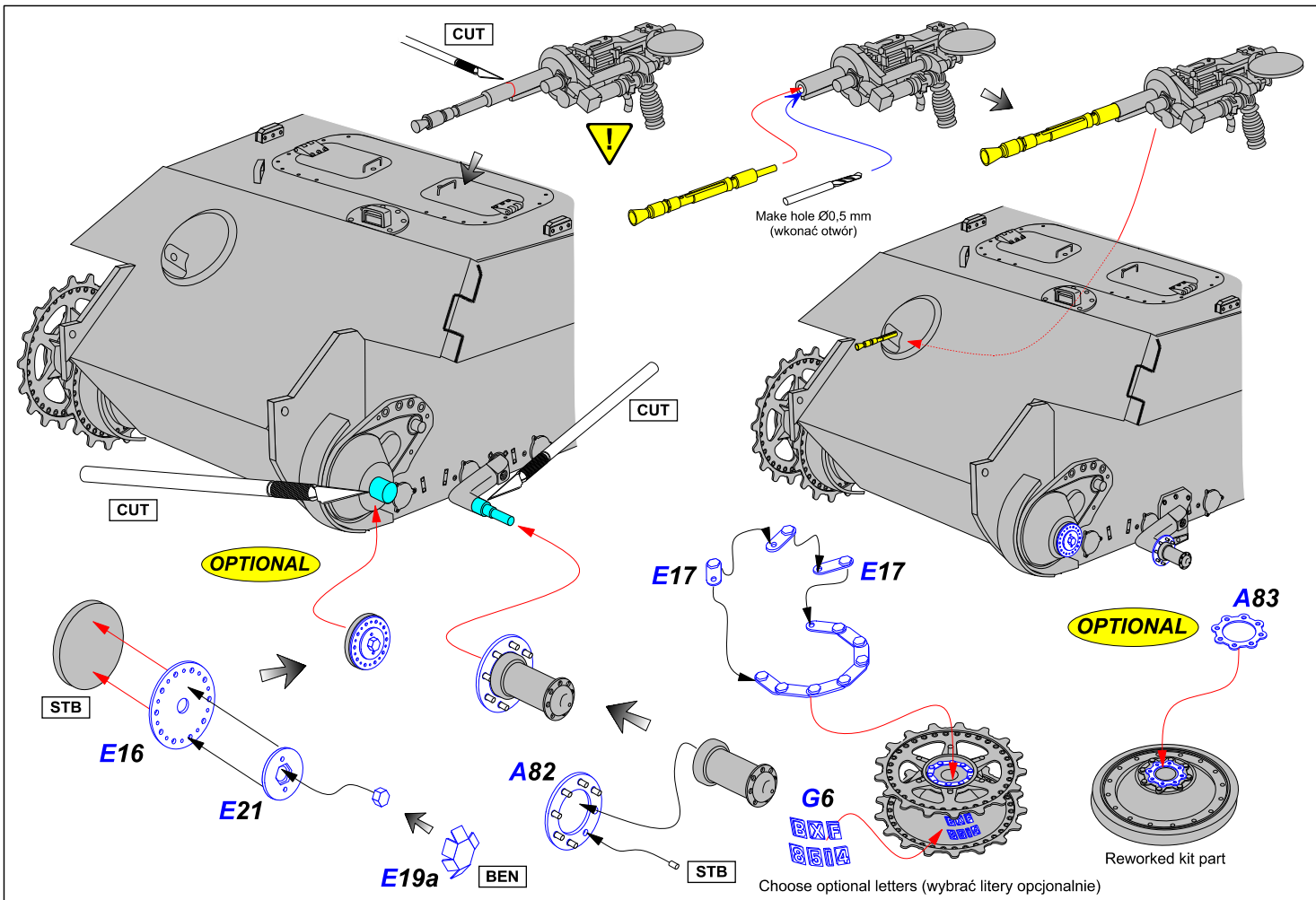

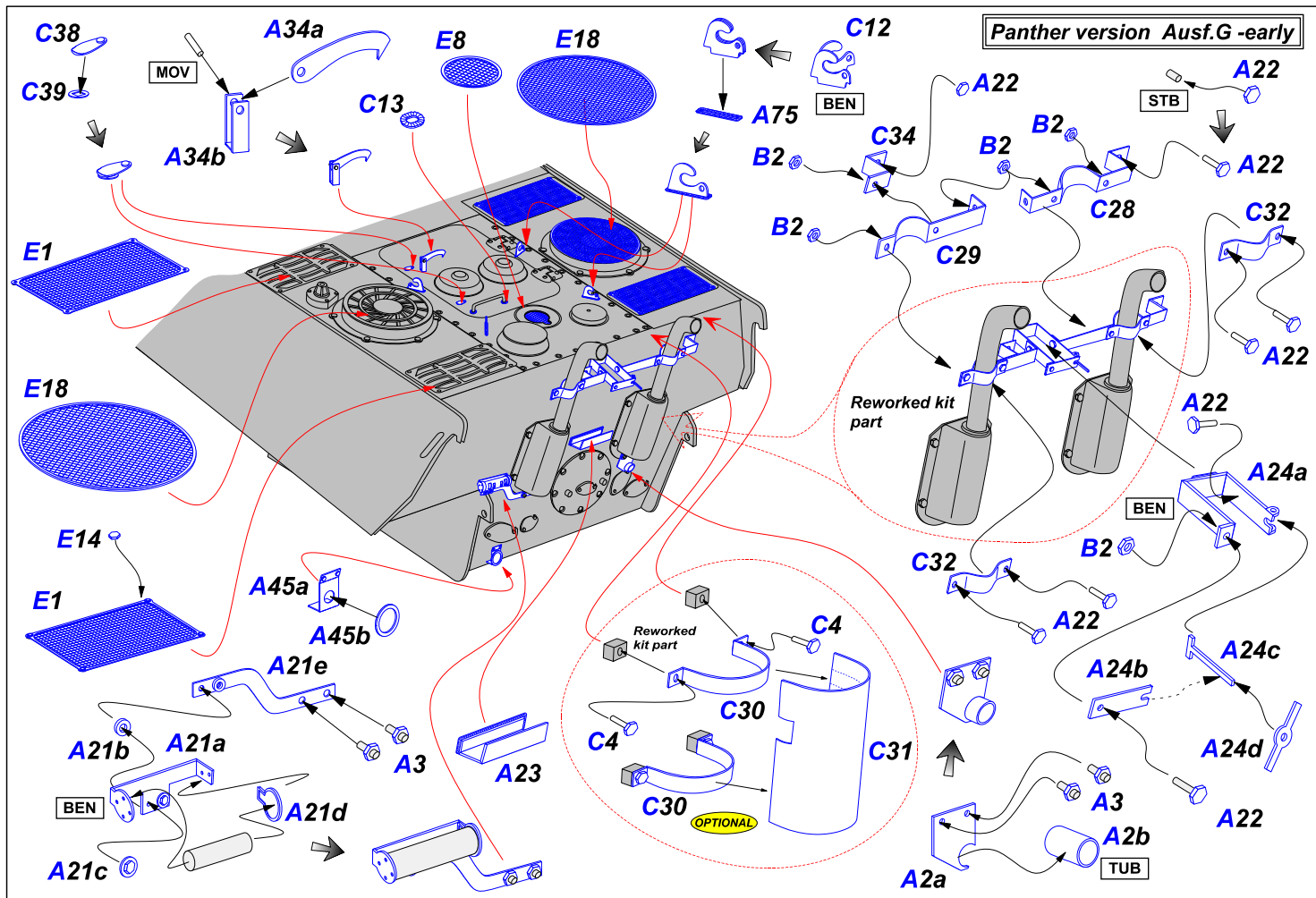

Panther version Ausf.G -late

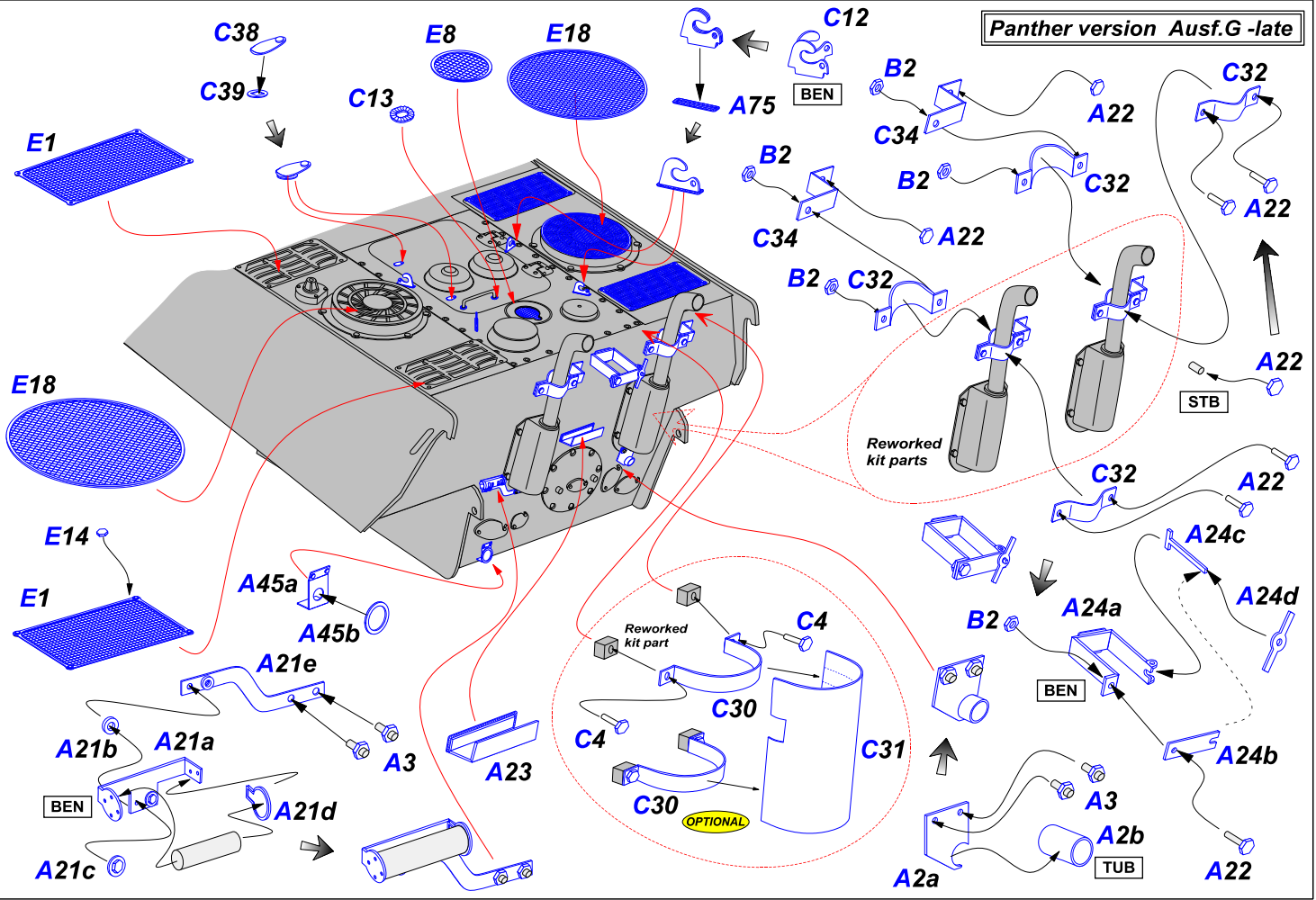

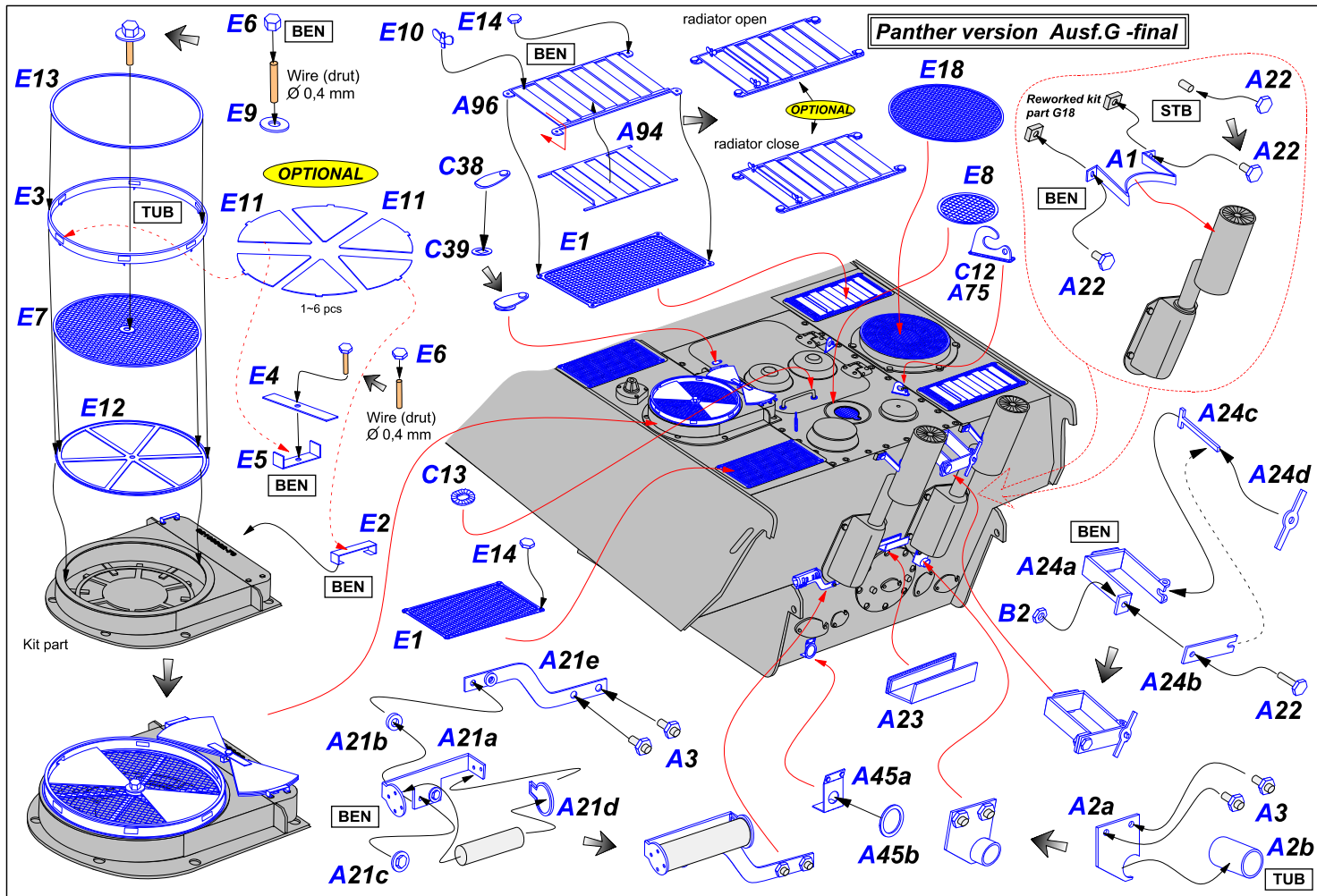



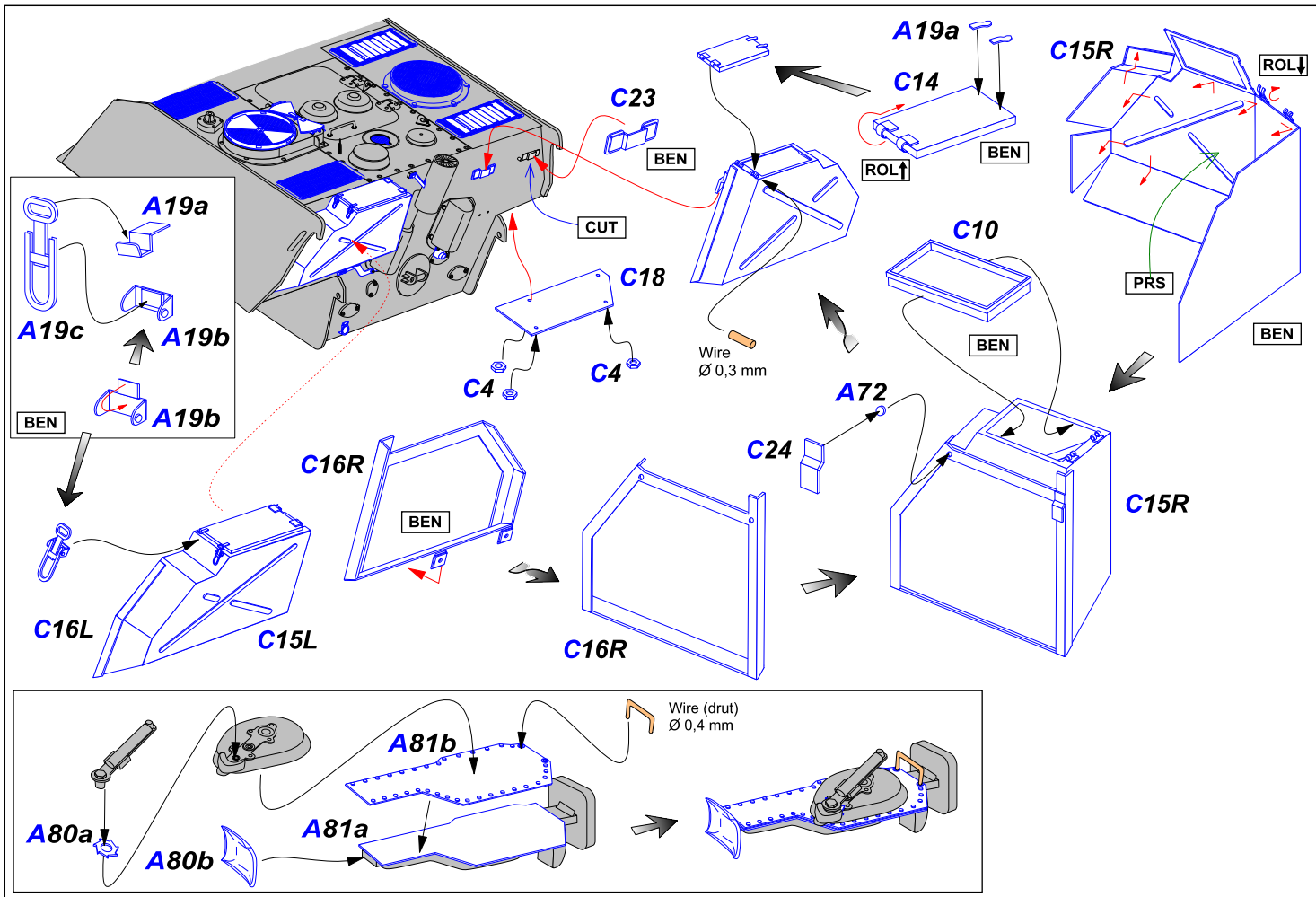

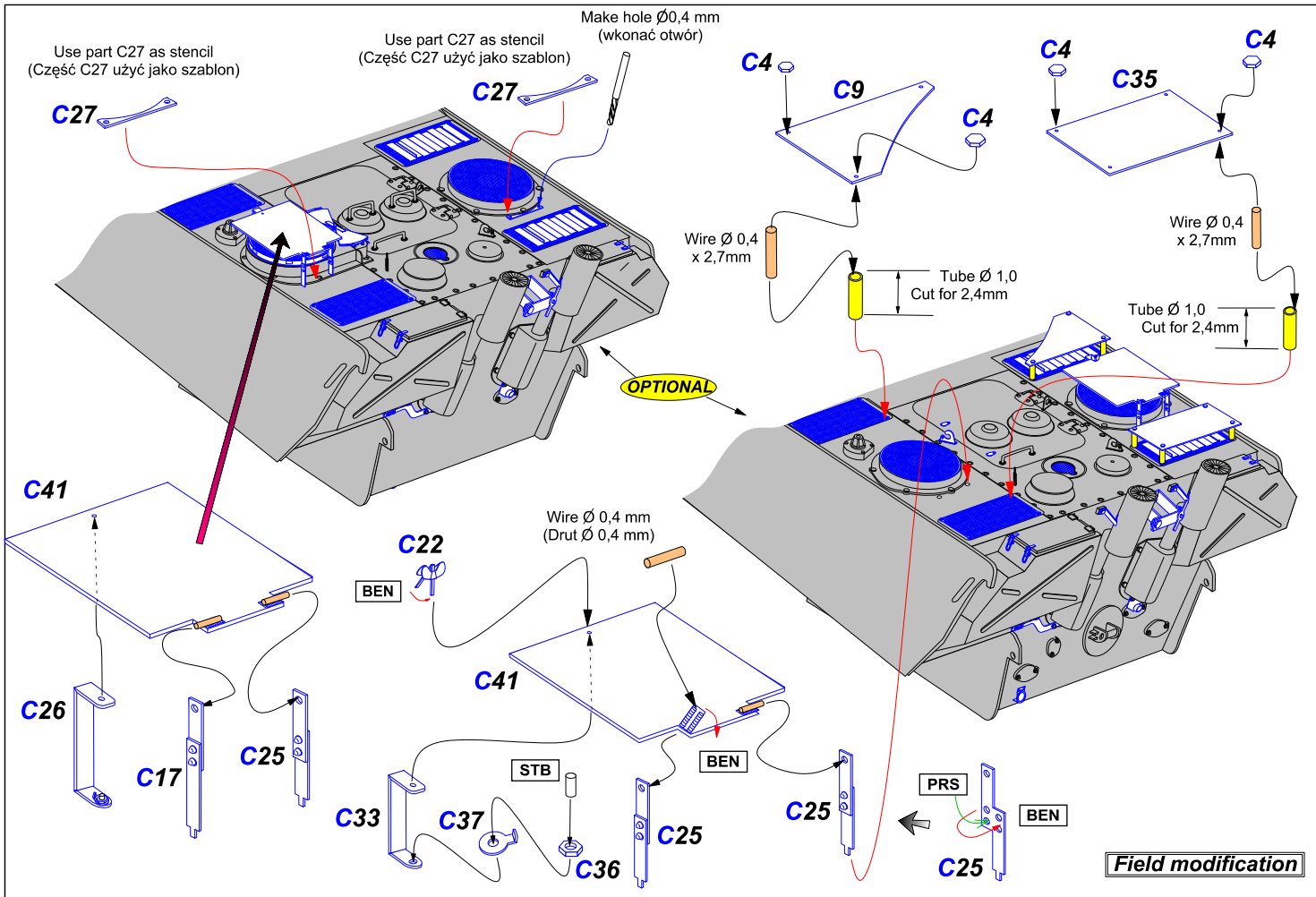

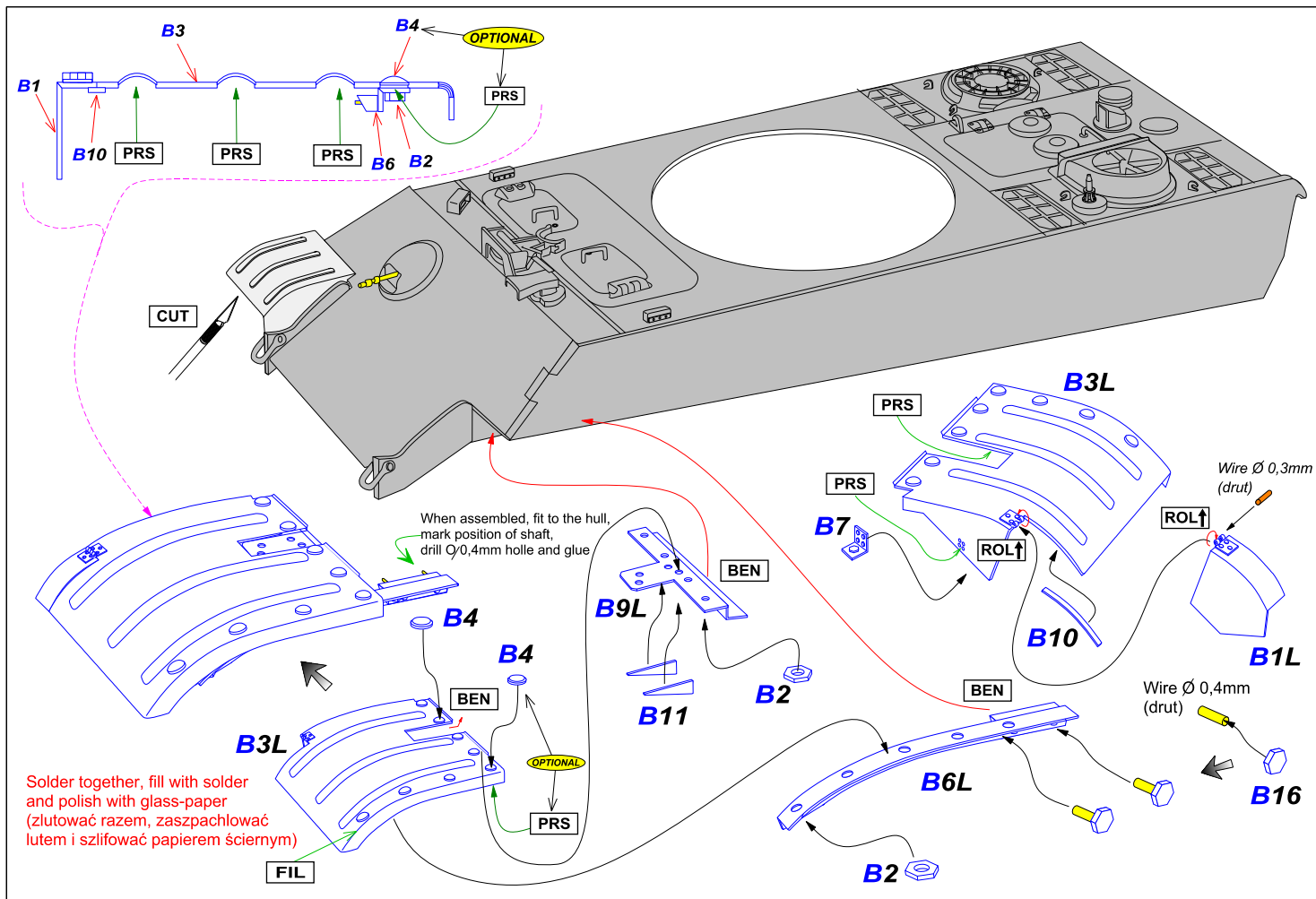

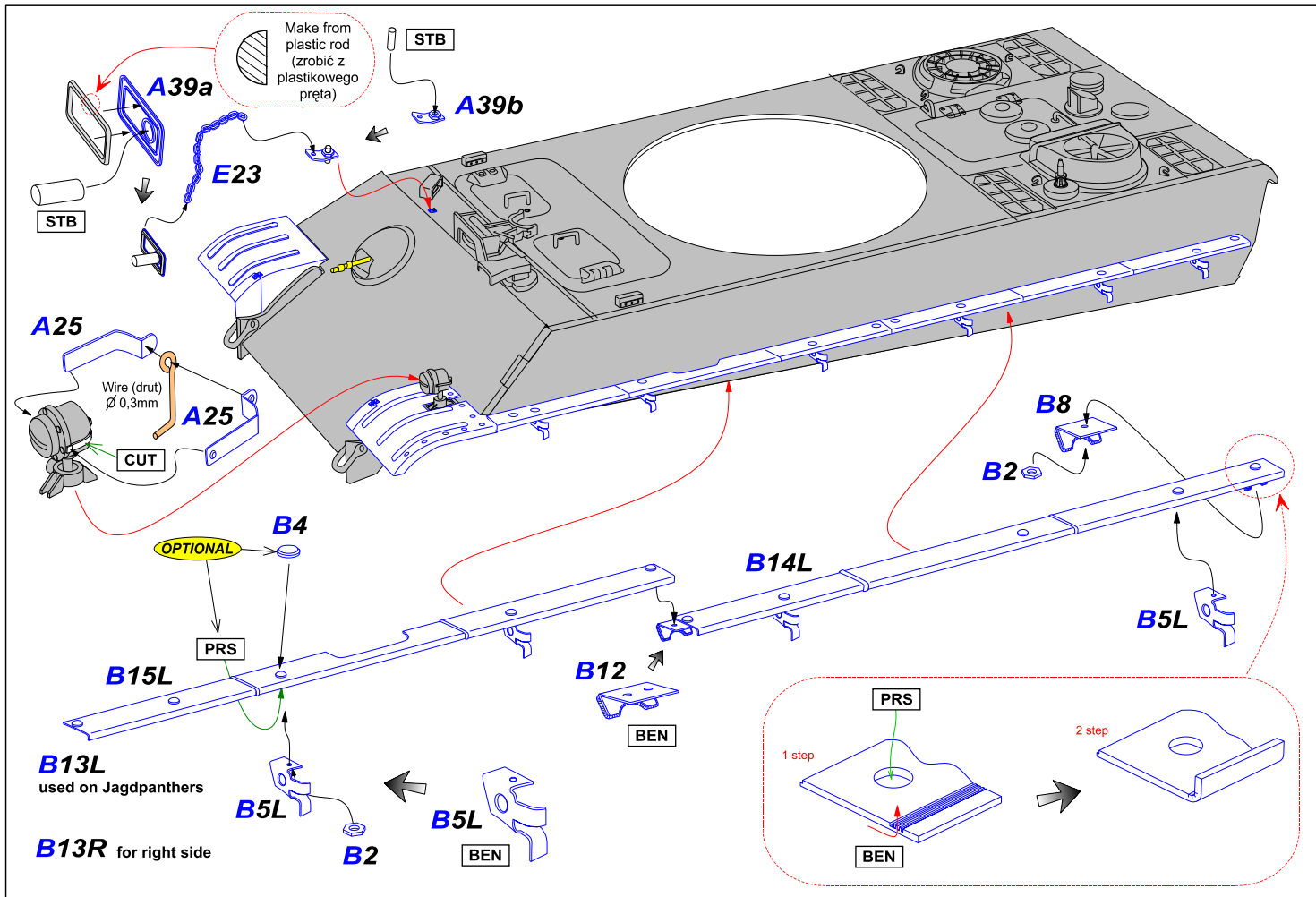

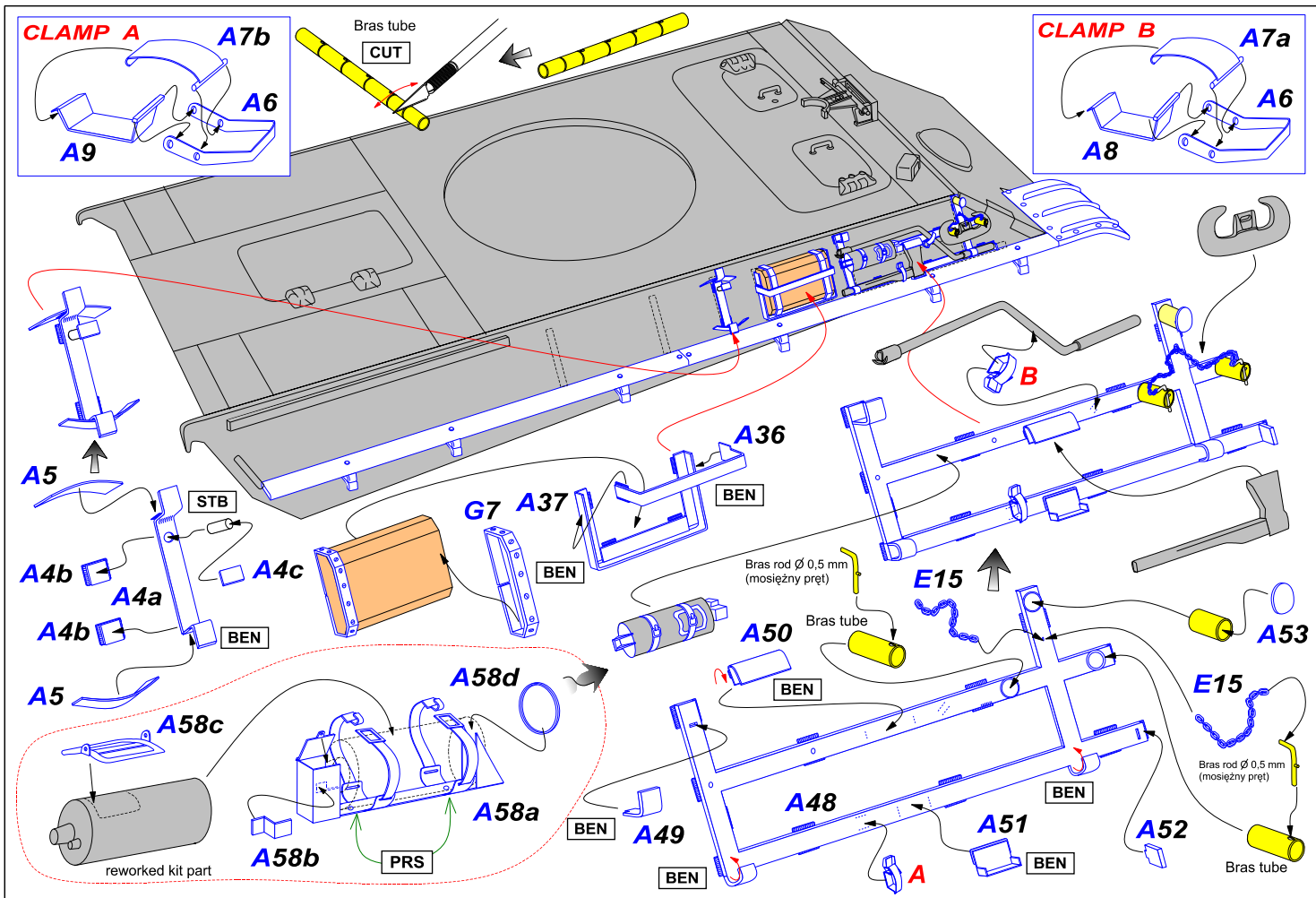

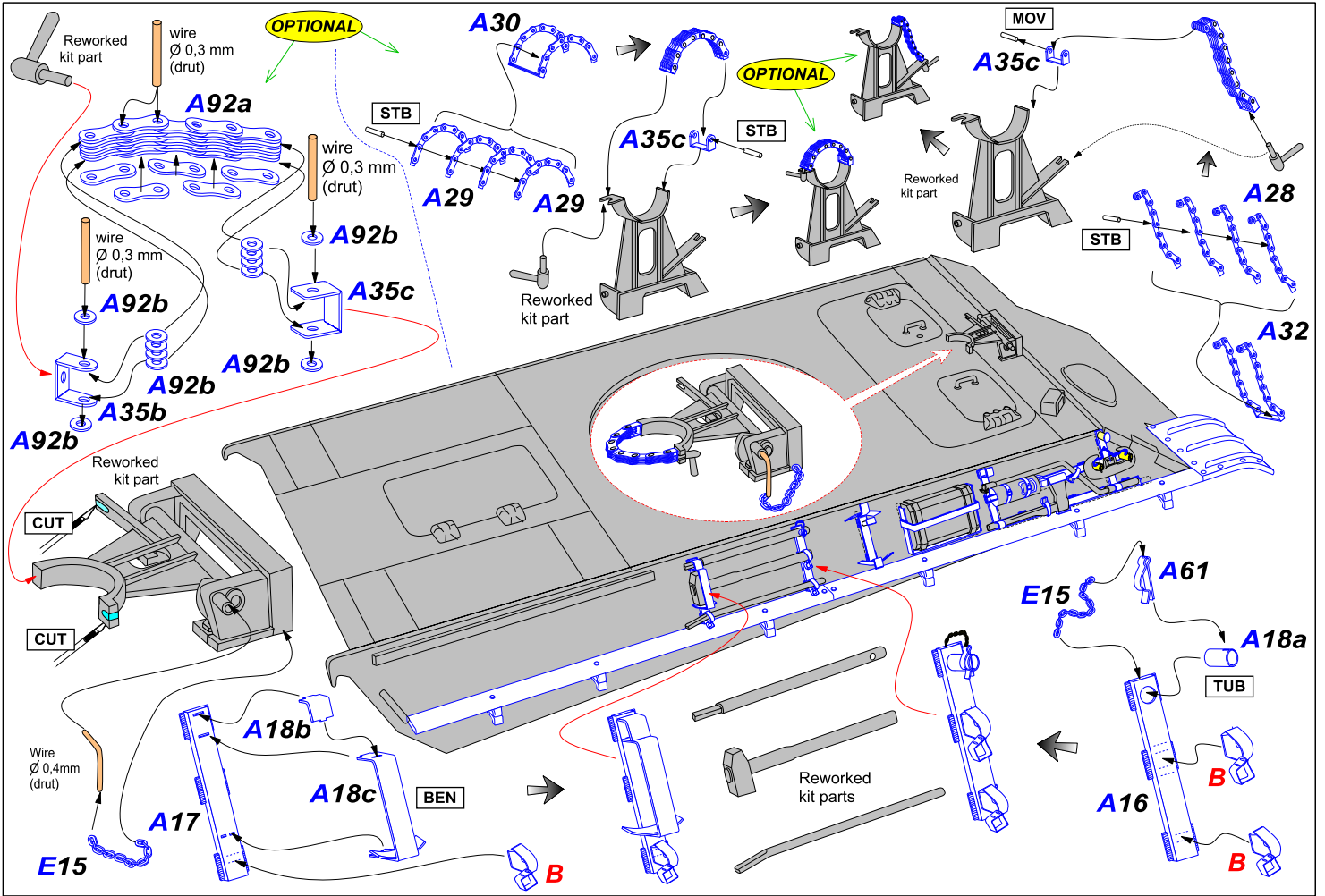

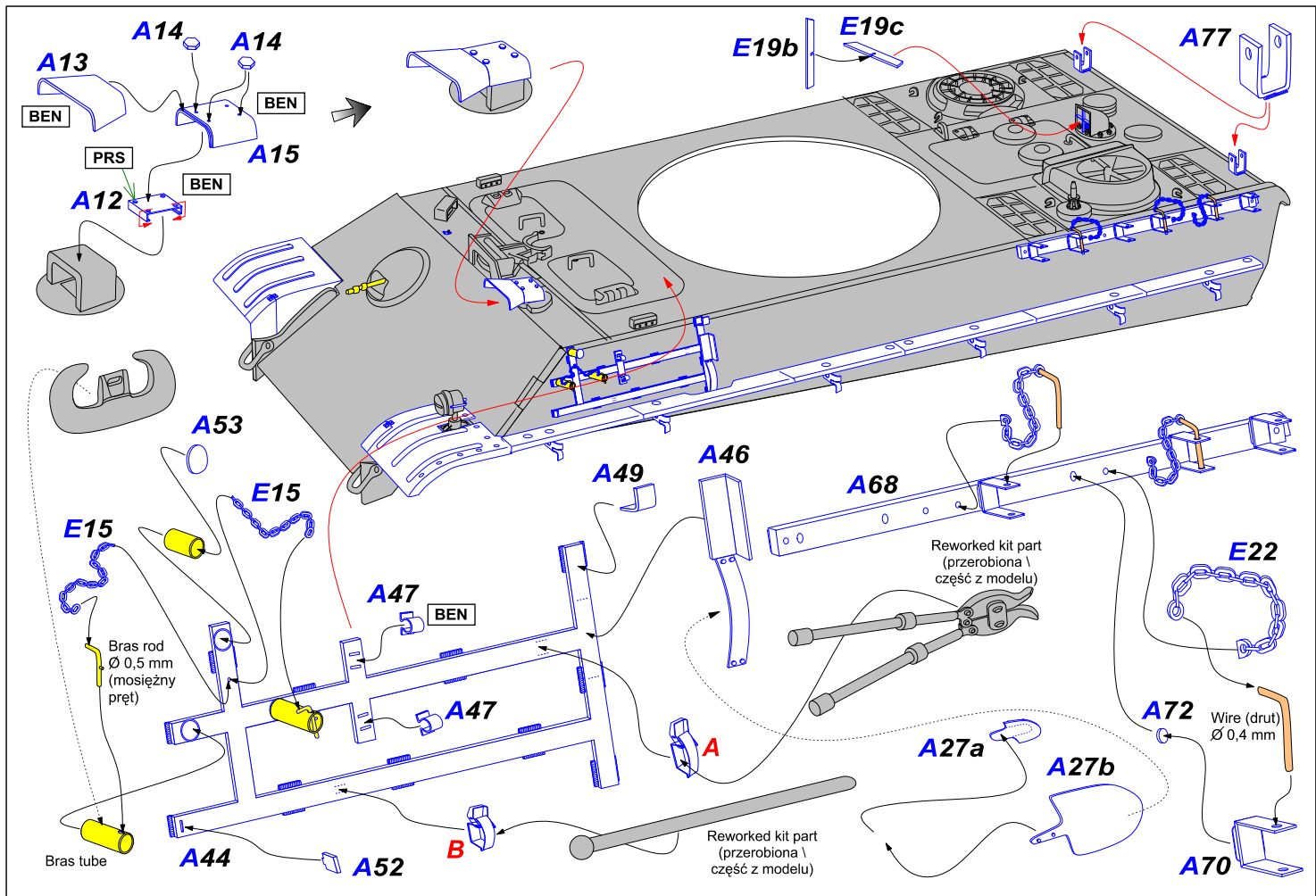

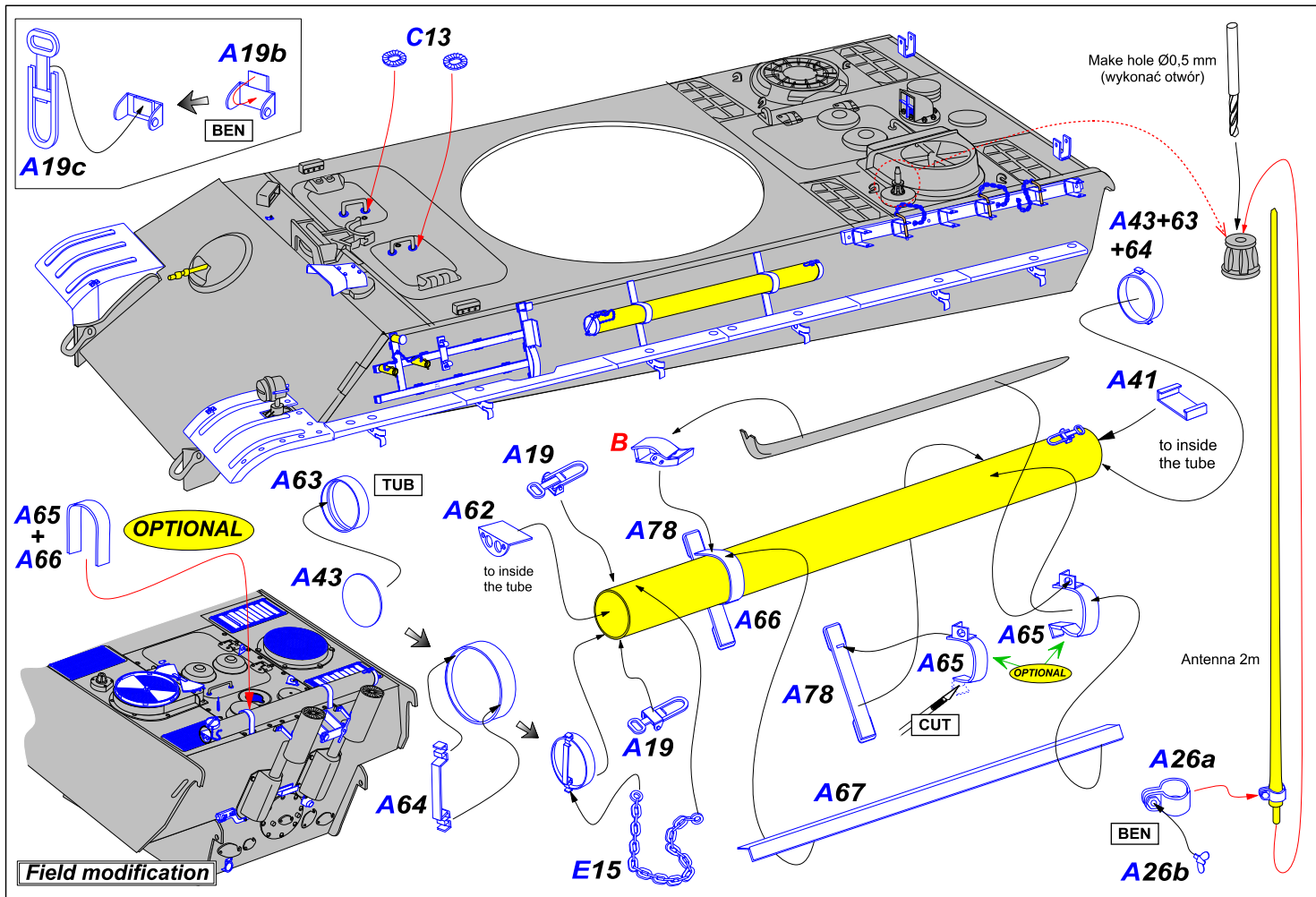



**Panzerbefehlswagen all version**

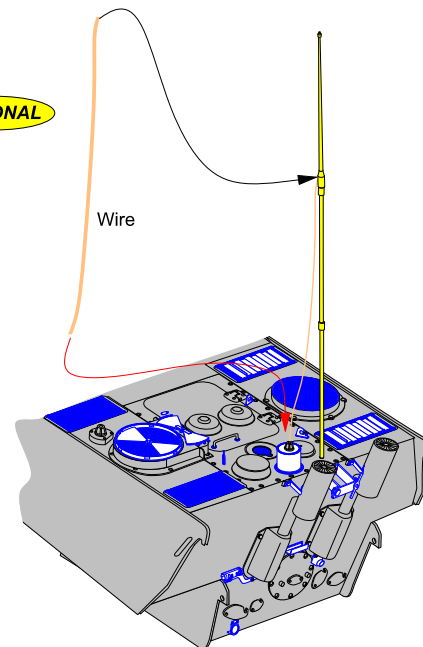
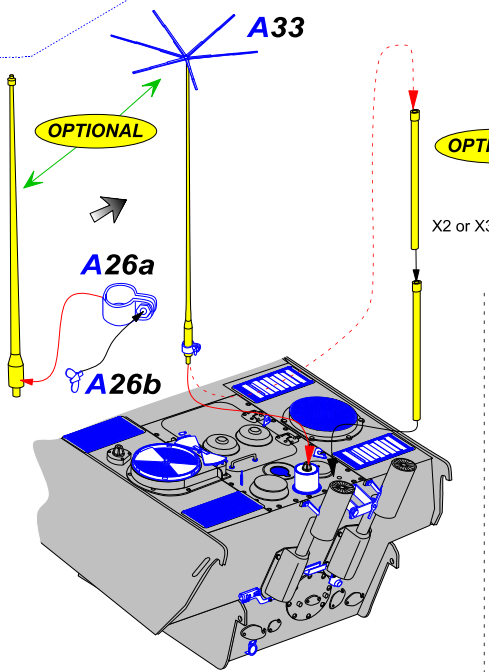
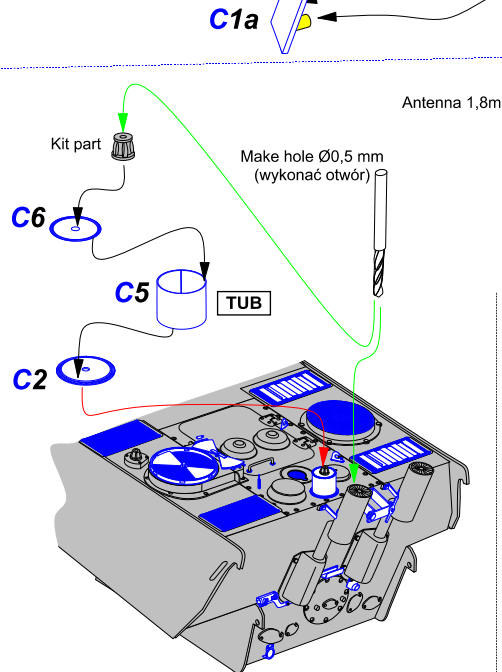
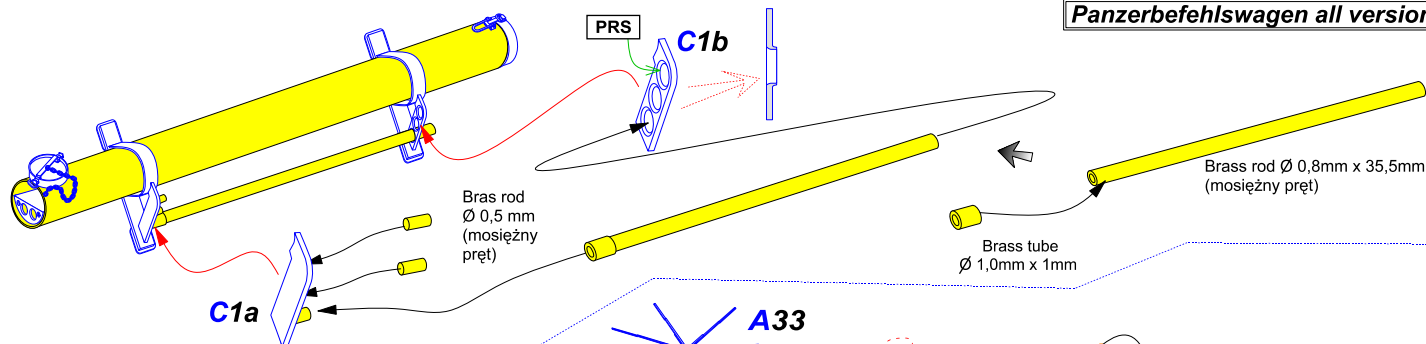

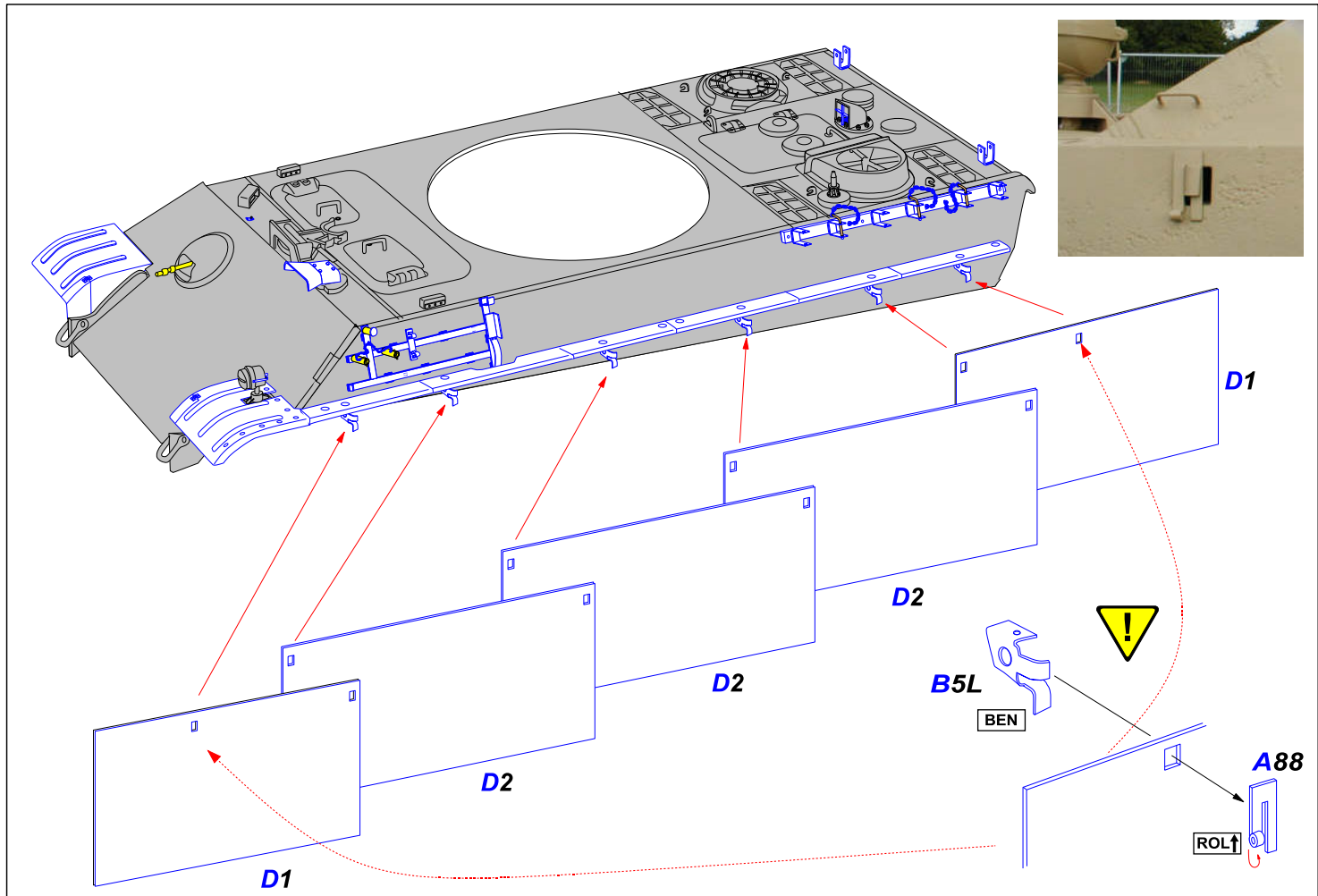

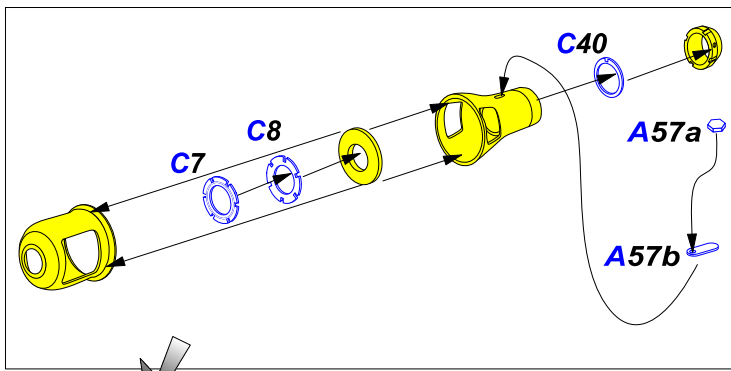

Use round needle-file if hole is too tight  
 (Zastosować iglak okrągły jeśli otwór jest za ciasny)

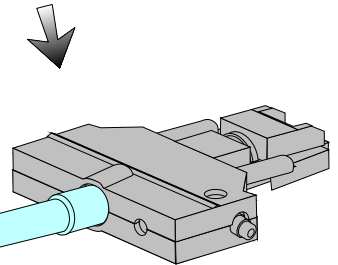
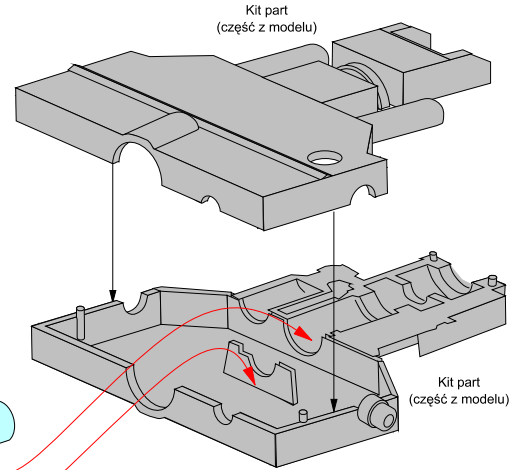
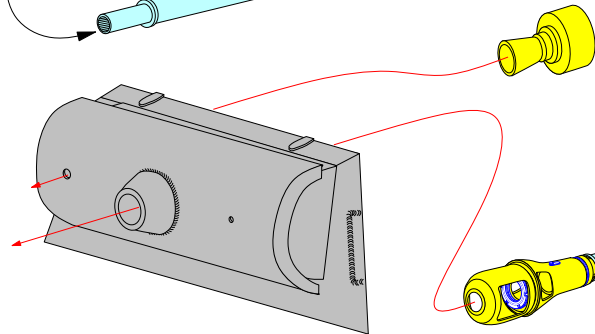
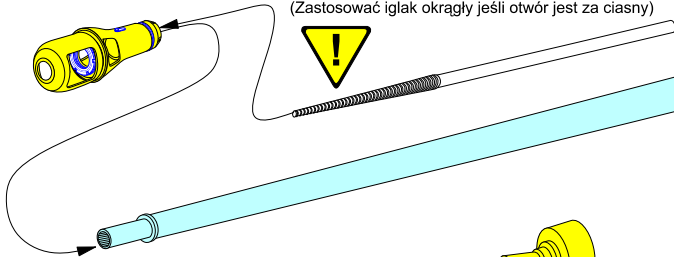

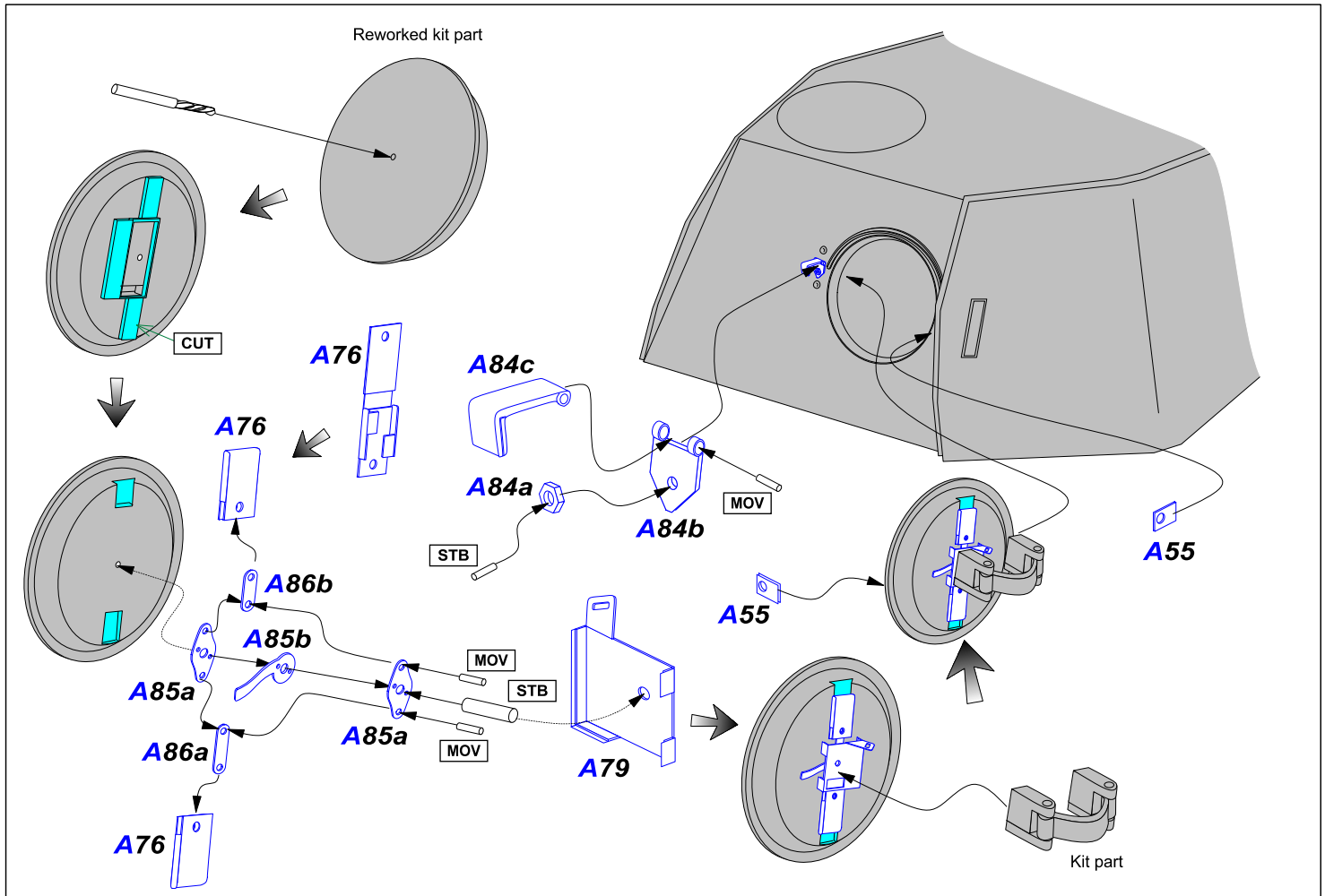

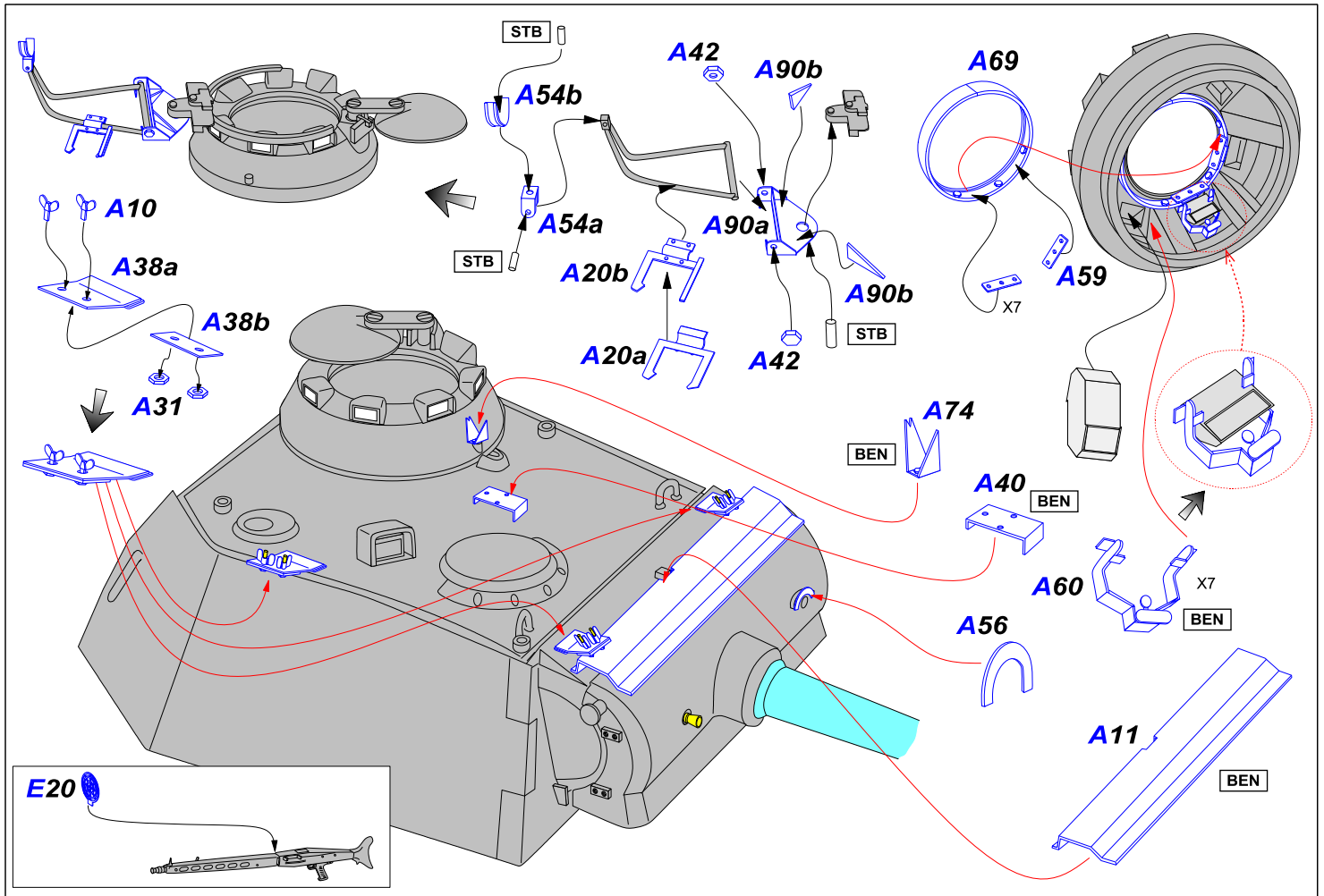

Make hole  $\varnothing 0,5$  mm and then light cavity  $\varnothing 1,1$  mm (wykonać otwór a następnie lekkie wgłębienie)

Use part F3 as stencil and mark holes (Część F3 użyć jako szablon do zaznaczenia otworów)

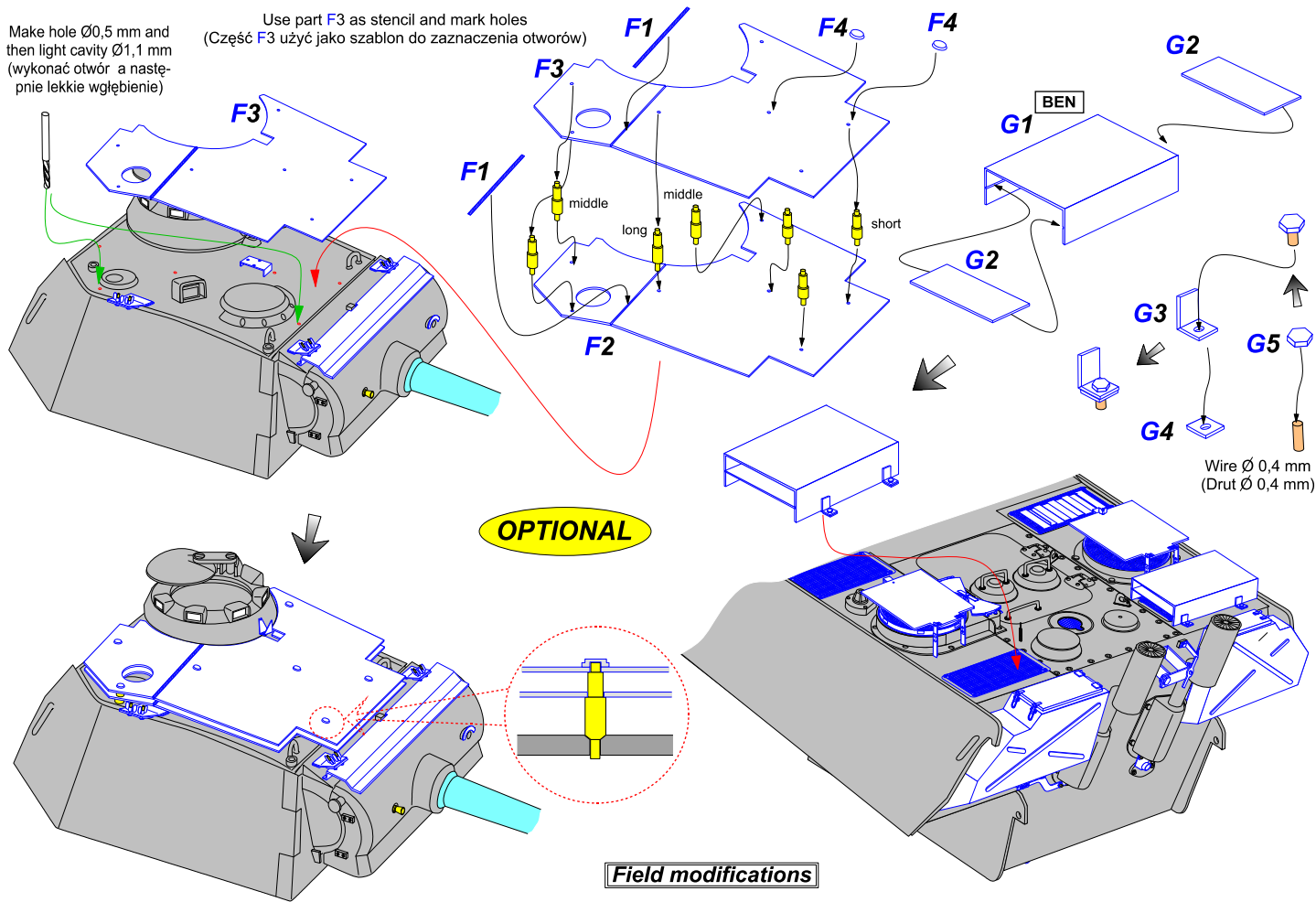

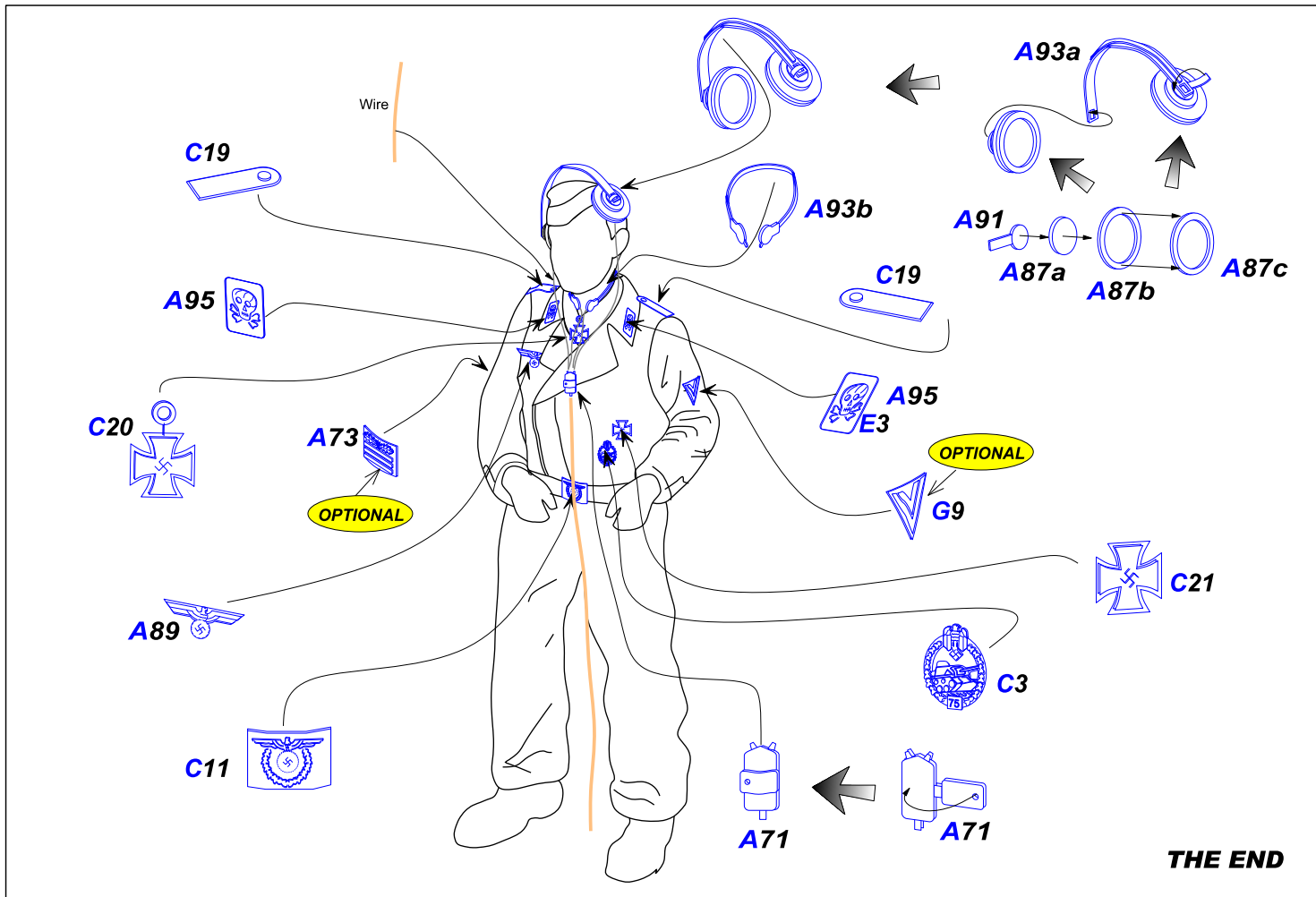

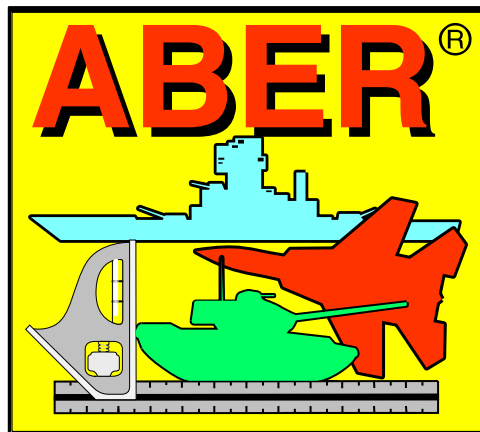

[WWW.ABER.NET.PL](http://WWW.ABER.NET.PL)