

STUKA JU87D

The ear-splitting screech of its sirens served as the introduction of the Ju 87 dive-bomber to France, Poland, the Balkans, Africa, England and Russia.

The first version of this famous plane, the Ju 87A-1 saw action in 1937 with the Condor Legion in Spain. Joined in 1938 and 1939 by the later Ju 87 B, the Junkers dive-bomber attained greater notoriety than any other weapon with which Germany launched the Second World War.

Within the first nine months of the war, the Ju 87 acquired an almost legendary reputation. This Junkers product became synonymous with the abbreviation "Stuka" – from Sturzkampfflugzeug, a term descriptive of all dive-bombers. The success of the Stuka lasted until August, 1940, when Germany launched its aerial

offensive on the British Isles. Ill-armed and outmaneuvered by the defending Spitfires and Hurricanes, the Stuka paid a fearful price for its role in the "Battle of Britain". By the end of August, the last of the Stuka Geschwader or dive-bomber wings were removed from action over Great Britain.

Following this debacle, the improved Ju 87D was introduced. This version was aerodynamically refined and featured a more powerful engine and heavier armament.

Your model can be completed as a Ju 87D-5 flown by Col. Hans-Ulrich Rudel, who destroyed over 500 Russian tanks, or a night intruder Ju 87D-8, operational on the Western Front in the last year of the war.



*** REPEAT SEVERAL TIMES**
* A REPETER PLUSIEURS FOIS



*** OPTIONAL PARTS**
* PIECES EN OPTION



*** DECAL**
* DECAL COMANIE



*** ALTERNATIVE ASSEMBLY**
* ENSEMBLAGE ALTERNATIVE



*** CEMENT TOGETHER**
* A COLLER



*** REMOVE AND THROW AWAY**
* A RETIRER ET JETER



*** DO NOT CEMENT**
* NE PAS COLLER

READ THIS BEFORE YOU BEGIN

- * Study the assembly drawings.
- * Each plastic part is identified by a number.
- * In the assembly drawings, some parts will be marked by a star (★) to indicate chrome plated plastic.
- * For better paint and decal adhesion, wash the plastic parts in a mild detergent solution. Rinse and let air dry.
- * Check the fit of each piece before cementing in place.
- * Use only cement for polystyrene plastic.
- * Scrape plating and paint from areas to be cemented.
- * Allow paint to dry thoroughly before handling parts.
- * Any unused parts may be discarded.

DECAL APPLICATION INSTRUCTIONS

1. Cut desired decal from sheet.
2. Dip decal in water for a few seconds.
3. Place wet decal on paper towel.
4. Wait until decal is movable on paper backing.
5. Place decal in position on model, face up and slide backing away.
6. Press out air bubbles with a soft damp cloth.
7. Milkiness that may appear is for better decal adhesion and will dry clear. Wipe away any excess adhesive.
8. Do not touch decal until fully dry.
9. Allow the decals 48 hours to dry before applying clear coat.

NOTE: Decals are compatible with setting solutions or solvents.

LIRE CE QUI SUIT AVANT DE COMMENCER

- * Etudier les schémas de montage.
- * Chaque pièce en plastique est identifiée par un numéro.
- * Sur les schémas de montage, certaines pièces sont marquées d'une étoile (★) pour indiquer qu'elles sont en plastique chromé.
- * Pour une meilleure prise de la peinture et des autocollants, laver les pièces en plastique avec une solution détergente peu concentrée. Les rincer et les laisser sécher à l'air.
- * Vérifier que chaque pièce s'ajuste bien avant de la coller en place.
- * N'utiliser que de la colle pour polystyrène.
- * Gratter les parties à coller pour enlever le chrome et la peinture.
- * Laisser la peinture bien sécher avant de manipuler les pièces.
- * Toute pièce inutilisée peut être jetée.

DIRECTIVES D'APPLICATION DES AUTOCOLLANTS

1. Découper l'autocollant désiré de la feuille.
2. Tremper l'autocollant dans de l'eau pendant quelques secondes.
3. Placer l'autocollant mouillé sur une serviette en papier.
4. Attendez que l'autocollant puisse être déplacé sur son support en papier.
5. Mettre l'autocollant en position sur le modèle face sur le dessus et faire glisser le support pour l'enlever.
6. Appuyer avec un chiffon doux humide pour éliminer les bulles d'air.
7. La substance laiteuse qui peut apparaître est destinée à améliorer l'adhésion de l'autocollant et devient incolore au séchage. Essuyer pour enlever tout excédent d'adhésif.
8. Ne pas toucher l'autocollant tant qu'il n'est pas bien sec.
9. Laisser l'autocollant sécher pendant 48 heures avant d'appliquer une couche transparente.

REMARQUE: Les autocollants sont compatibles avec les solutions de fixation ou les solvants.

This paint guide is provided to complete this kit as shown on the box.

Ce guide de peintures est fourni pour reproduire le modèle réduit qui apparaît sur la boîte.

Black Green	Vert Tres Fonce
Dark Green	Vert Fonce
Light Blue	Bleu Clair
Dark Gray	Gris Fonce
Yellow	Jaune
Green	Vert
Steel	Acier
Blue	Bleu
Brown	Brun
Skin Color	Couleur De La Peau
White	Blanc
Flat Black	Noir Terne

*Colors with asterix are not included in the kit and are added for detail.

*Des couleurs avec l'asterix ne sont pas incluses dans le kit et sont ajoutées pour le détail.

If you have any questions or comments, call our hotline at: **(800) 833-3570**
or, please write to:

Revell-Monogram Consumer Service Department, 725 Landwehr Road, Northbrook, Illinois 60062

Be sure to include the plan number (85525000200), part number, description, your return address and phone number.

Visit our website: www.revell.com

1

COCKPIT ASSEMBLY

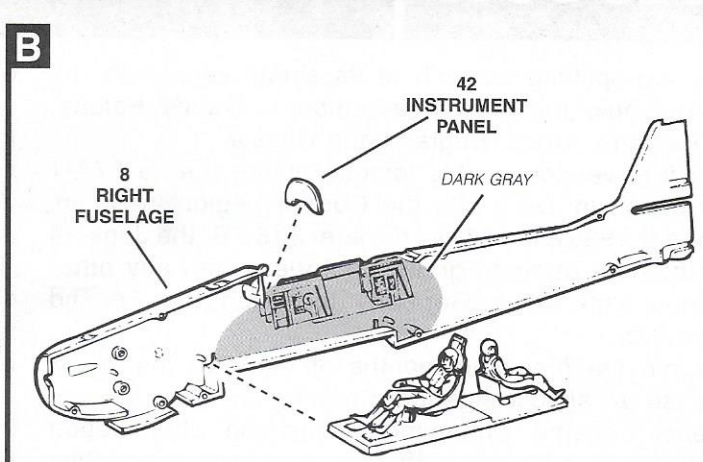
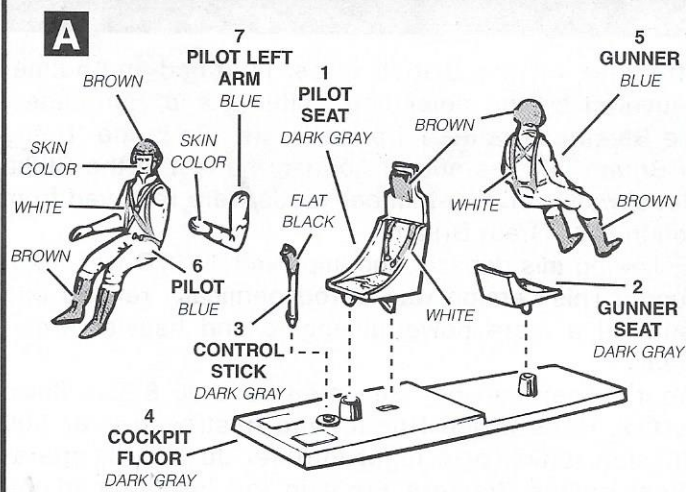

2

FUSELAGE ASSEMBLY

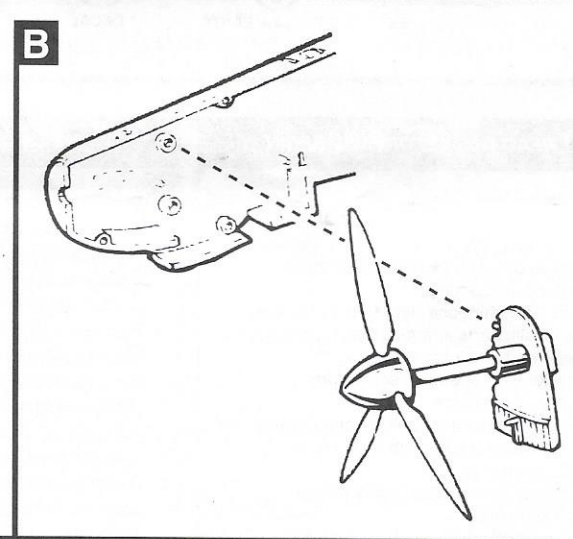
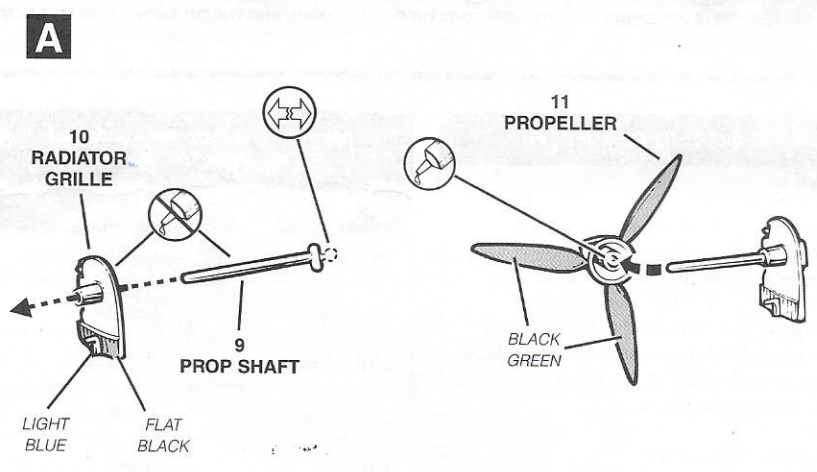

C

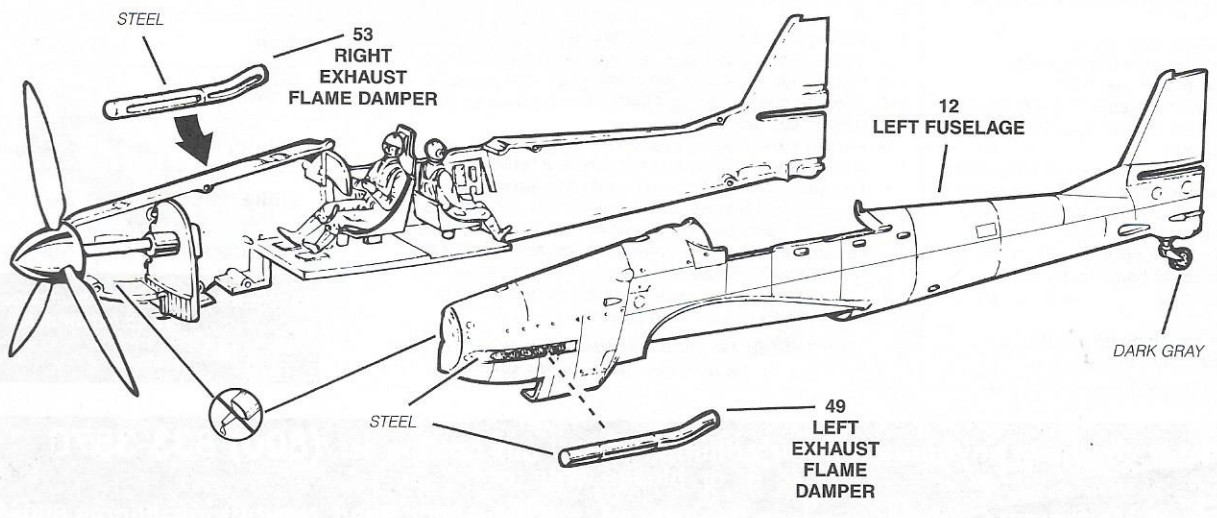

3

WING ASSEMBLY

A

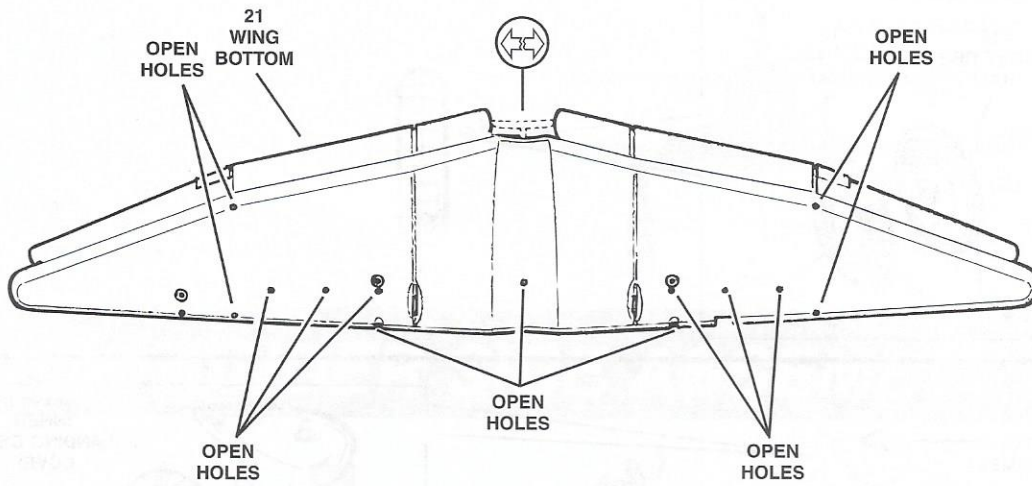

B

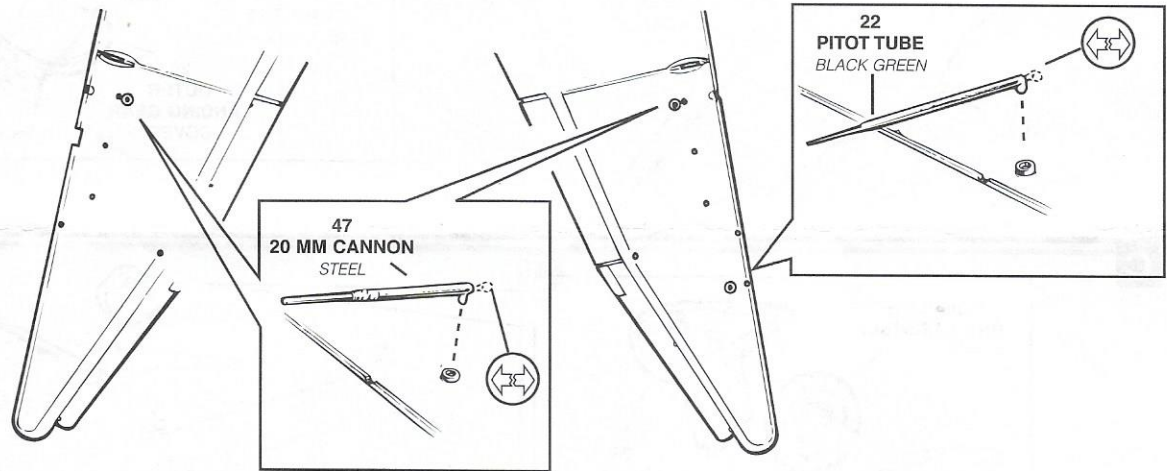

C

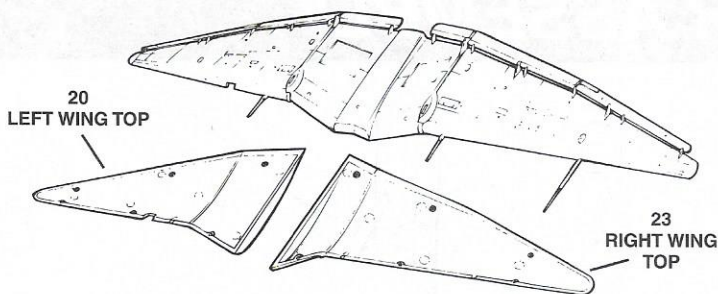

D

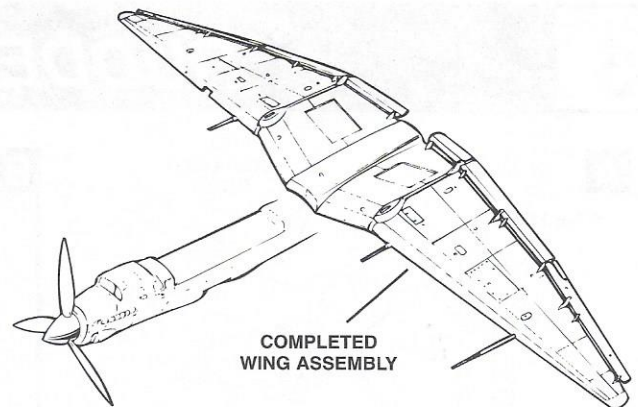

4

WHEEL ASSEMBLY

A

2X

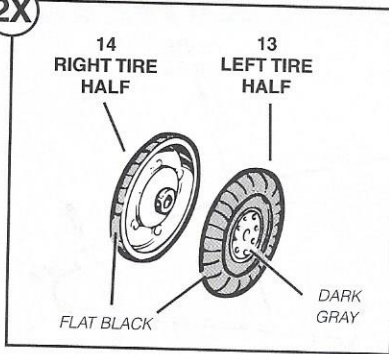

B

COMPLETE WHEEL ASSEMBLY

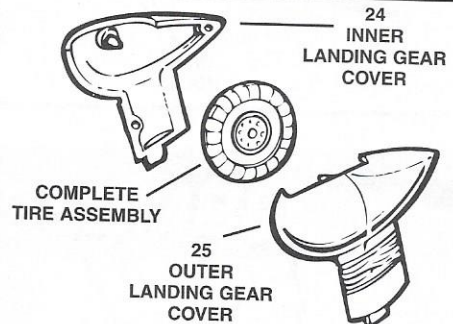
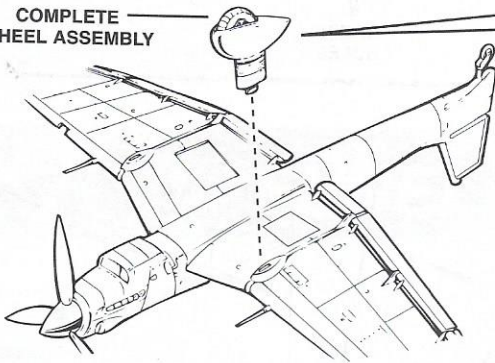

C

COMPLETE TIRE ASSEMBLY

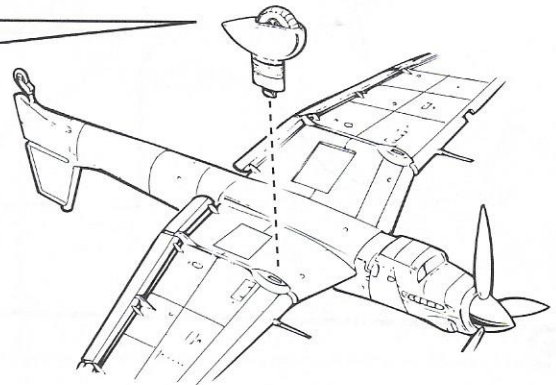
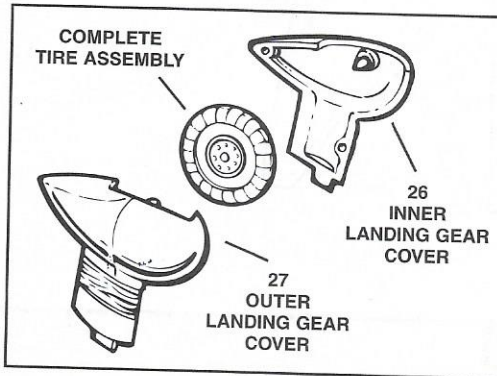

5

RUDDER ASSEMBLY

A

31 STABILIZER

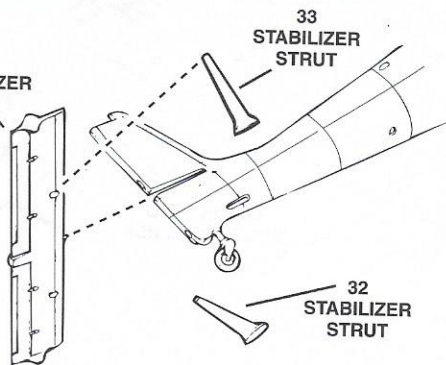

B

34 RUDDER

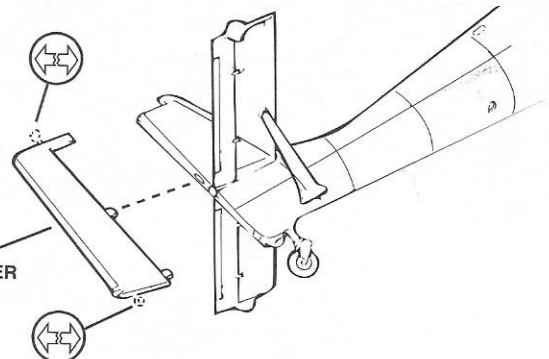

5

RUDDER ASSEMBLY CONTINUED

C

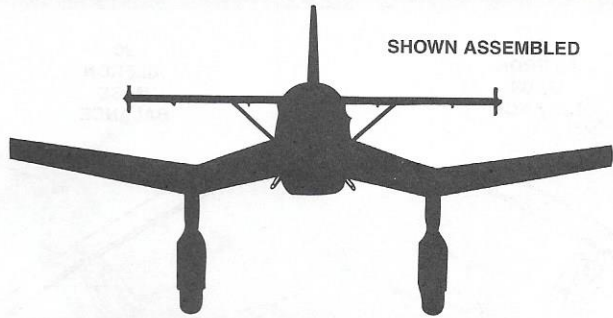
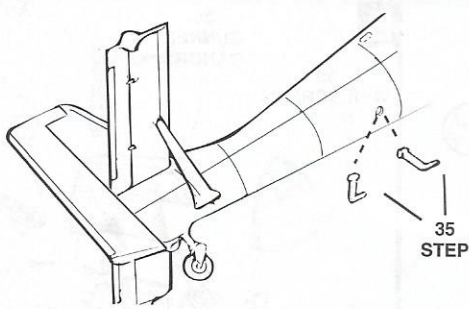

6

UNDER SIDE ASSEMBLY

A

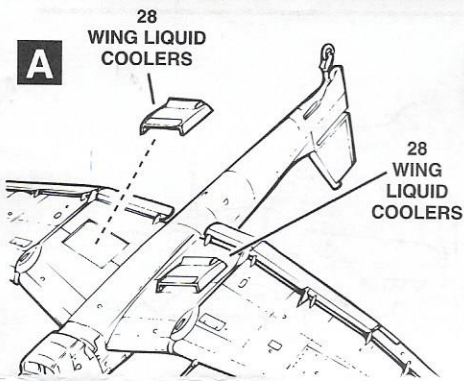

B

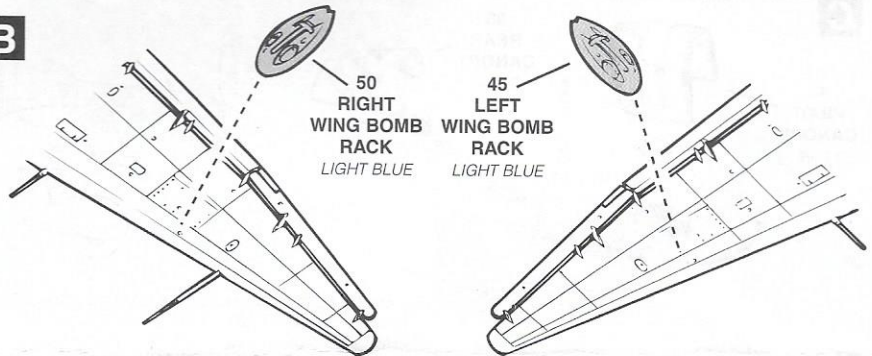

C

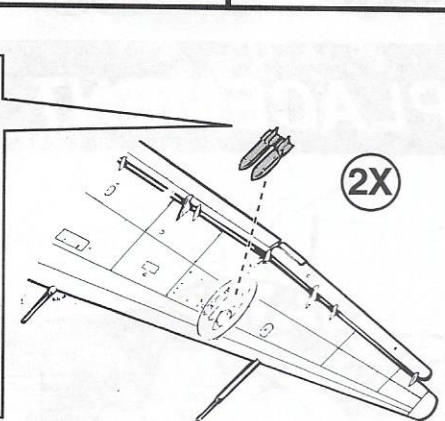
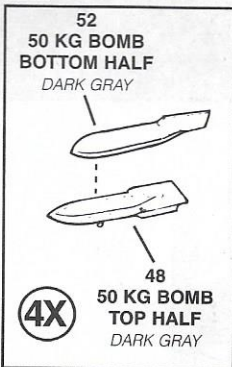

D

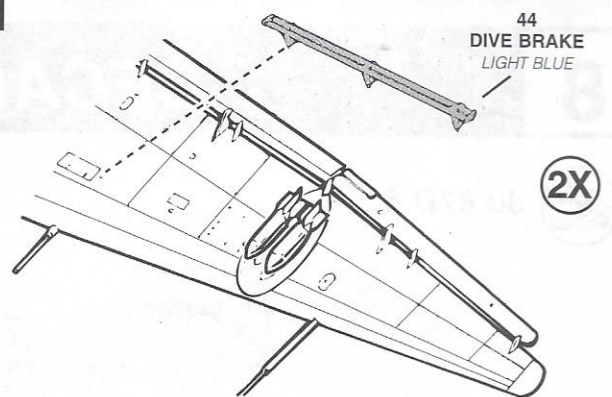

E

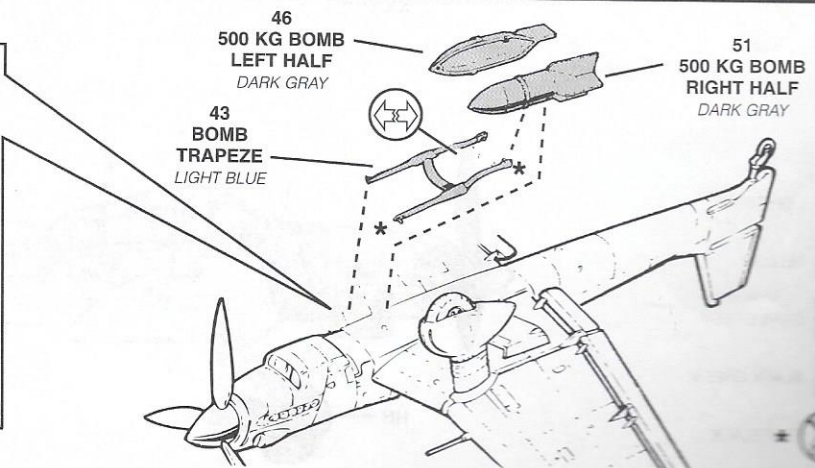
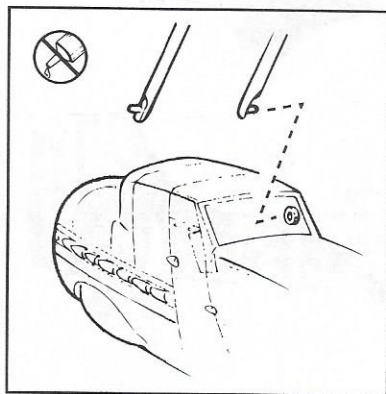

7

FINAL ASSEMBLY

A

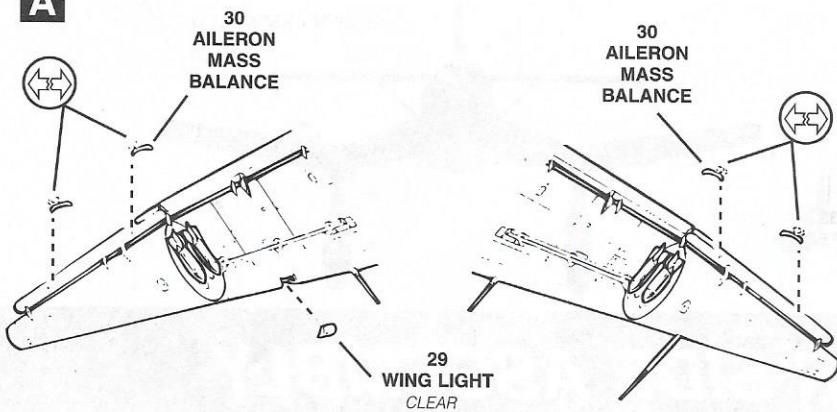

B

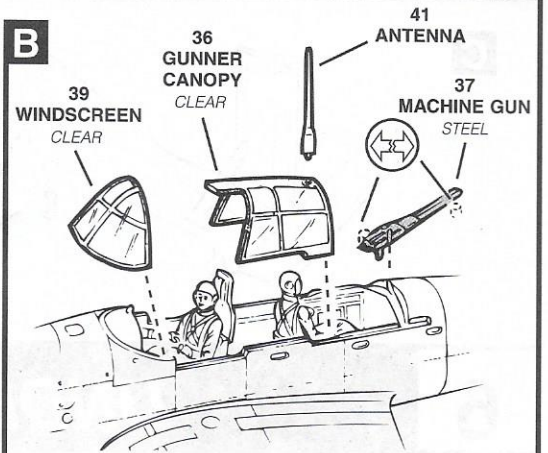

C

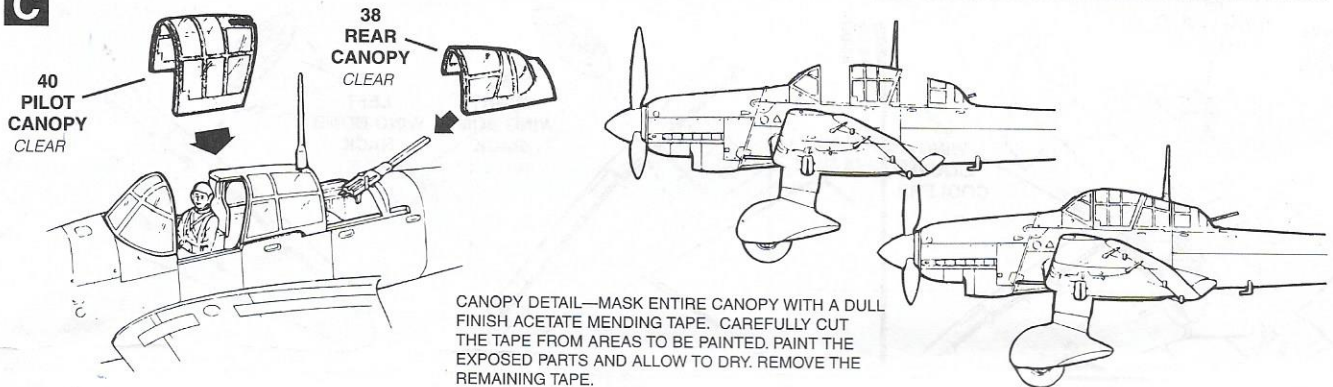

8

DECAL PLACEMENT



Ju 87D-5

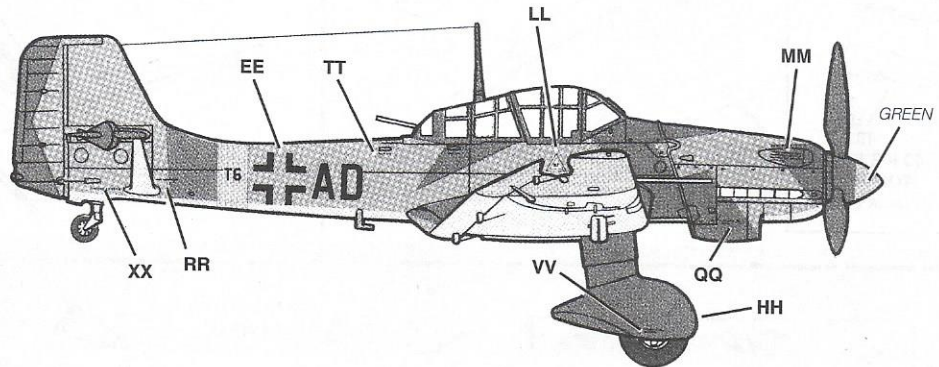

-  LIGHT BLUE
-  YELLOW
-  DARK GREEN
-  BLACK GREEN
-  FLAT BLACK

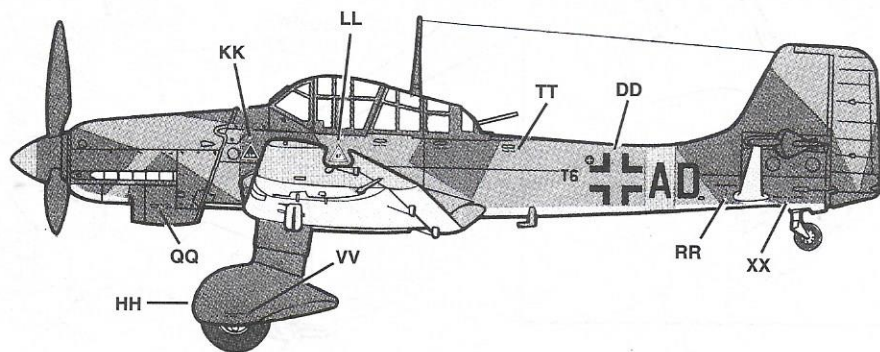

8

DECAL PLACEMENT VERSION JU87D-5 CONTINUED



Ju 87D-5

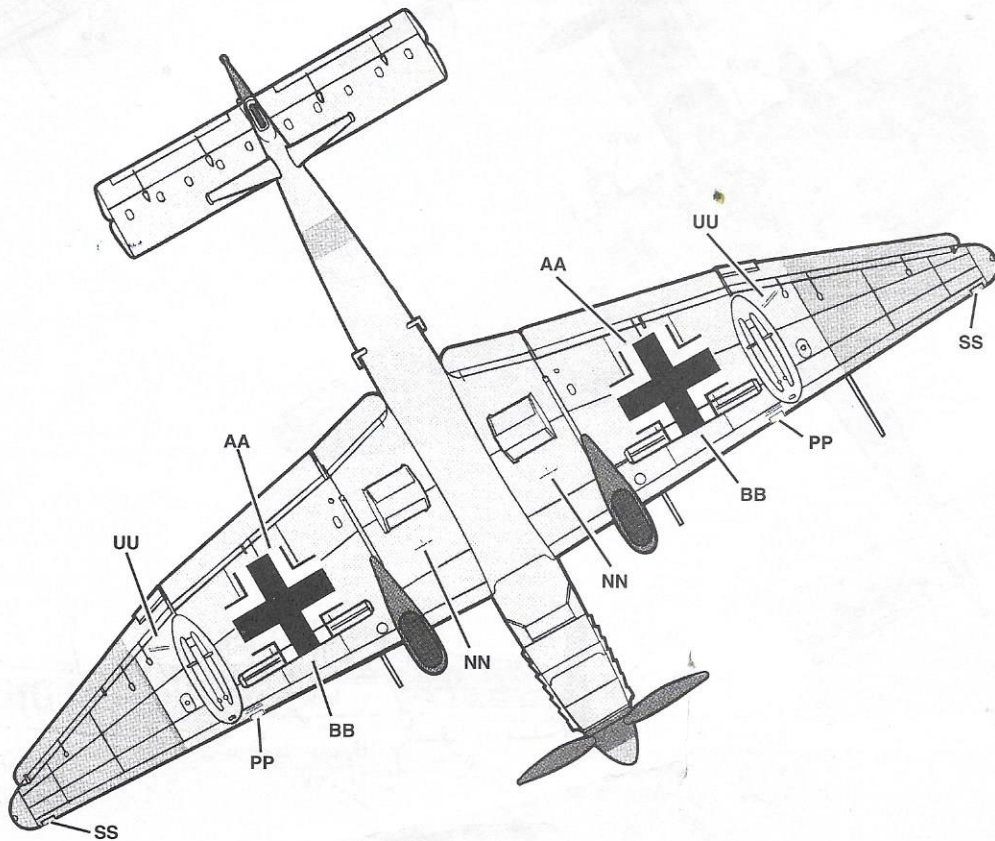
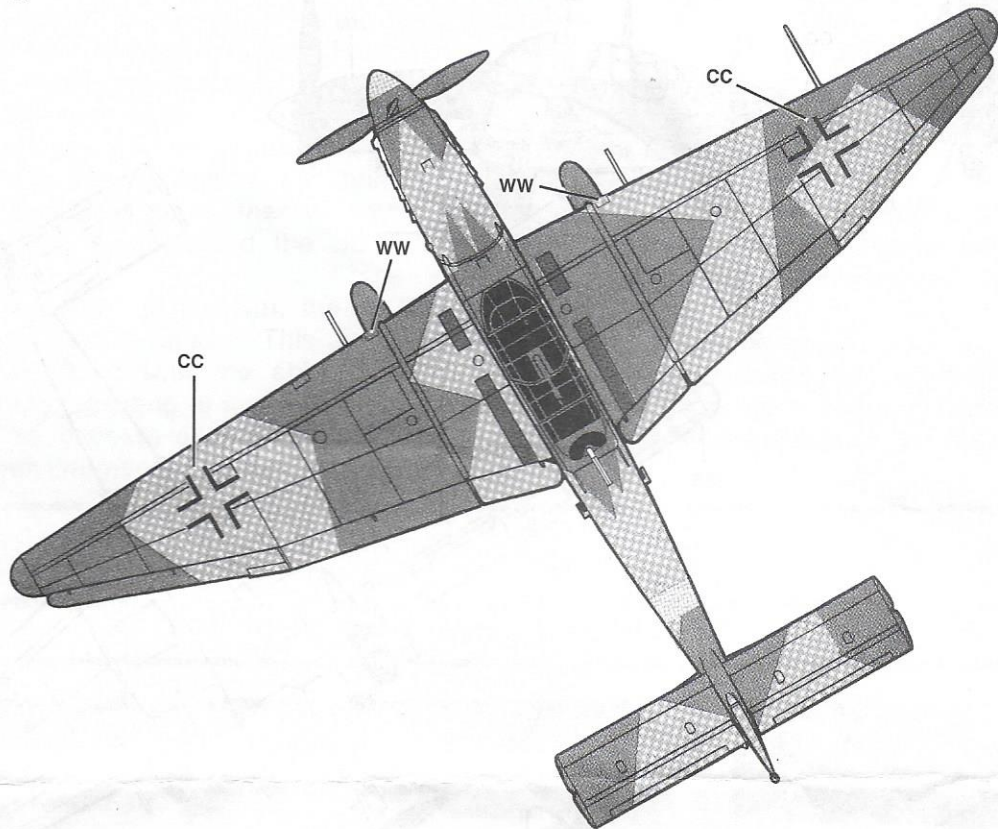

DECAL PLACEMENT

Ju 87D-8

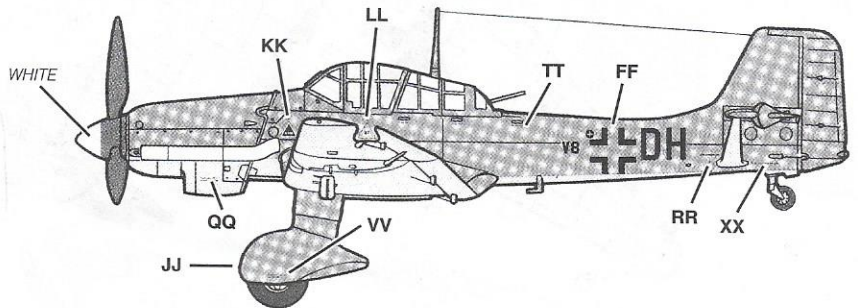
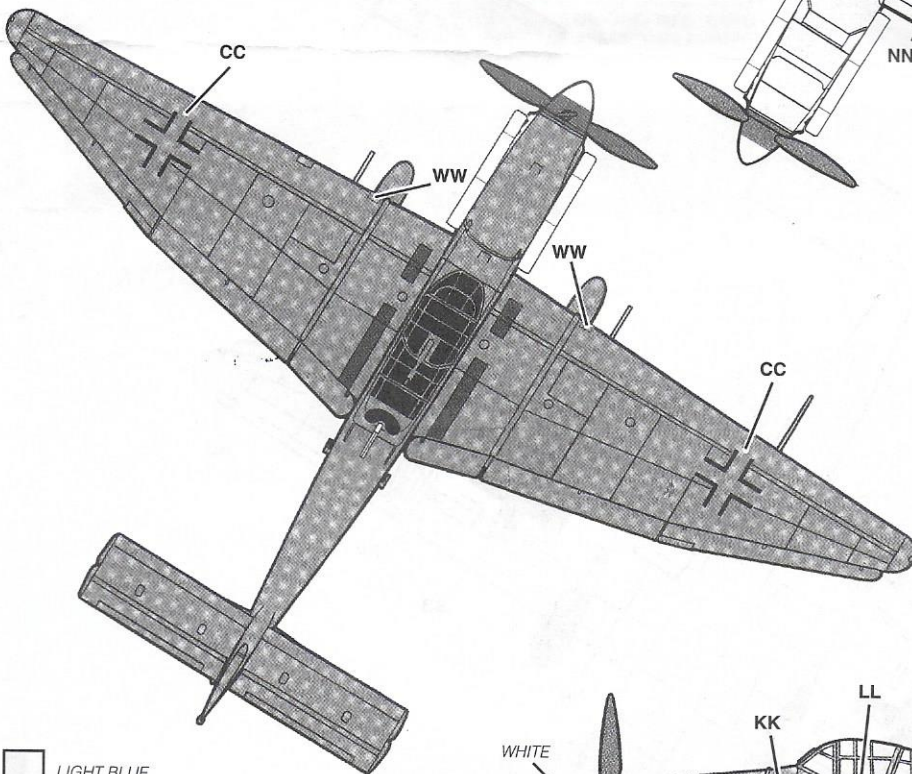
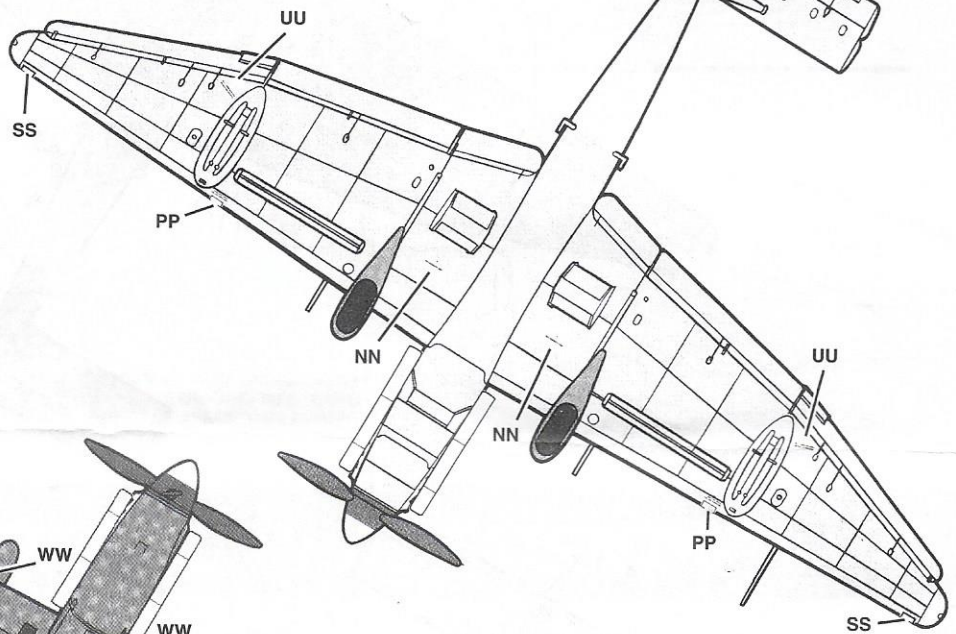
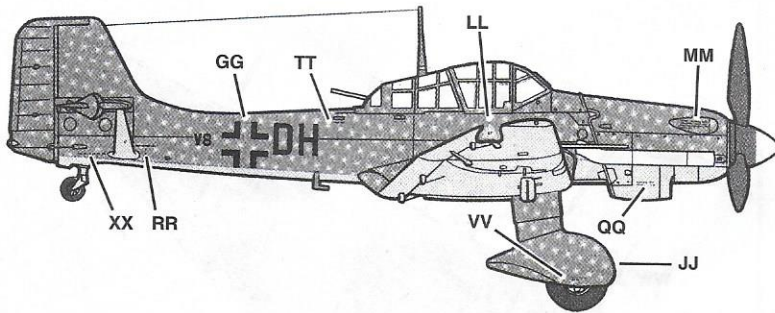

-  LIGHT BLUE
-  DARK GREEN
-  BLACK GREEN
-  FLAT BLACK