

I numeri si riferiscono all'assortimento colori ITALERI Model Master / Acryl Paint System  
 The indicated colour numbers refer to the ITALERI Model Master / Acryl Paint System  
 Die angegebenen Farbnummern beziehen sich auf die ITALERI Model Master / Acryl Paint System  
 Les références indiquées concernent les peintures ITALERI Model Master / Acryl Paint System

**C**

WHITE (SEMGLOSS)  
 F.S. 27875  
 ITA MM - 1596  
 ITA MM ACRYL - 4701

**D**

GUN METAL (METALIZER)  
 ITA MM - 1405  
 ITA MM ACRYL - 4681

**E**

LIGHT GHOST GRAY (FLAT)  
 F.S. 36375  
 ITA MM - 1728  
 ITA MM ACRYL - 4762

**F**

RED (FLAT)  
 ITA MM - 1550  
 ITA MM ACRYL - 4714

**A**

ALUMINIUM (METALIZER)  
 ITA MM - 1401  
 ITA MM ACRYL - 4677

**B**

BLACK (FLAT)  
 F.S. 37038  
 ITA MM - 1749  
 ITA MM ACRYL - 4768

**G**

STAINLESS STEEL (METALIZER)  
 ITA MM - 1402  
 ITA MM ACRYL - 4679

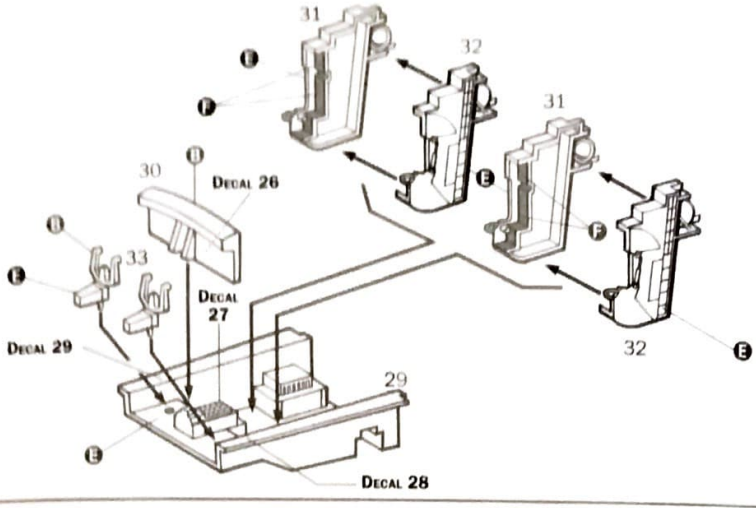
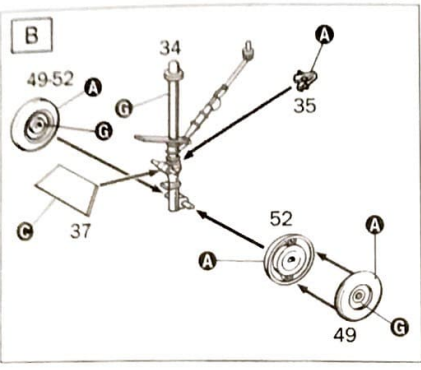
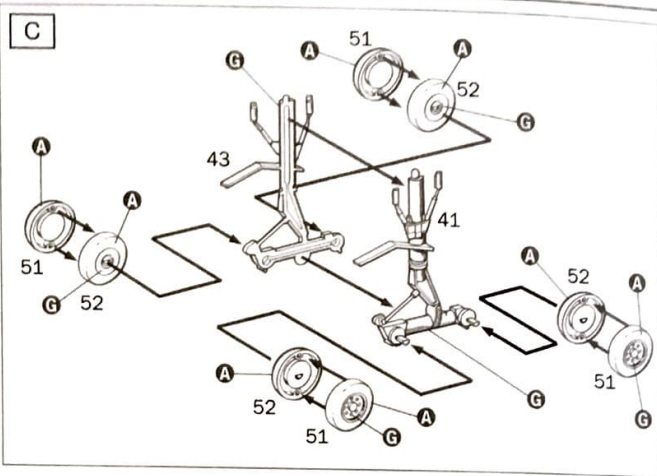
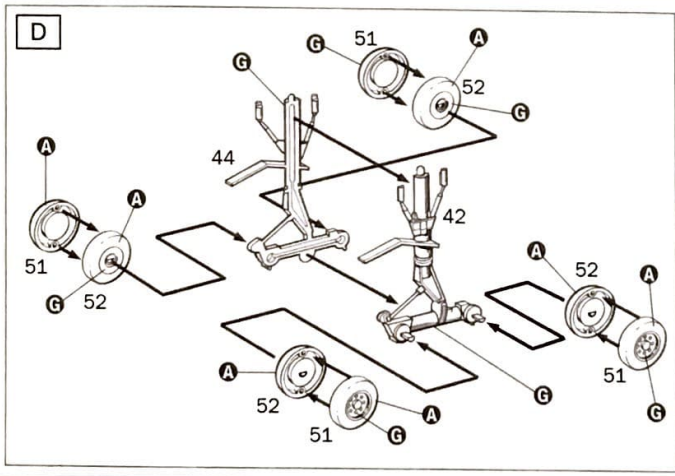
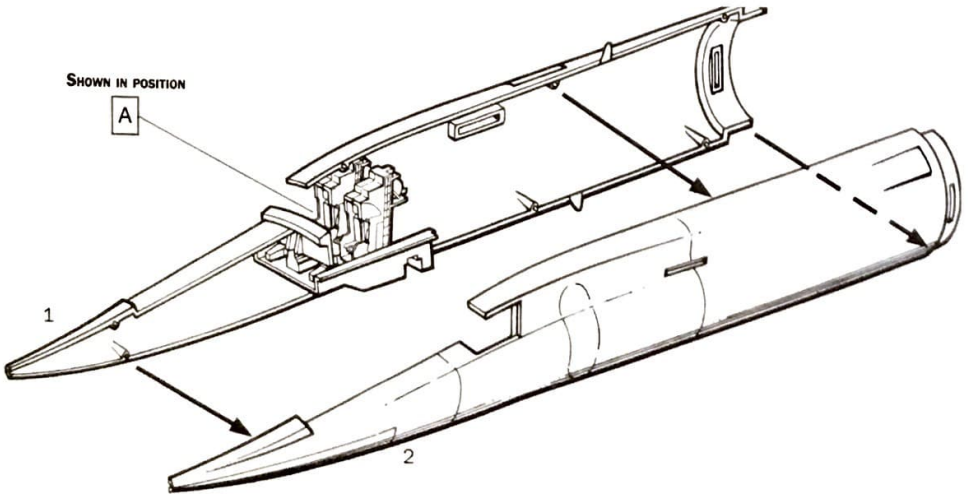
**1****A****2****B****C****D****3****E**

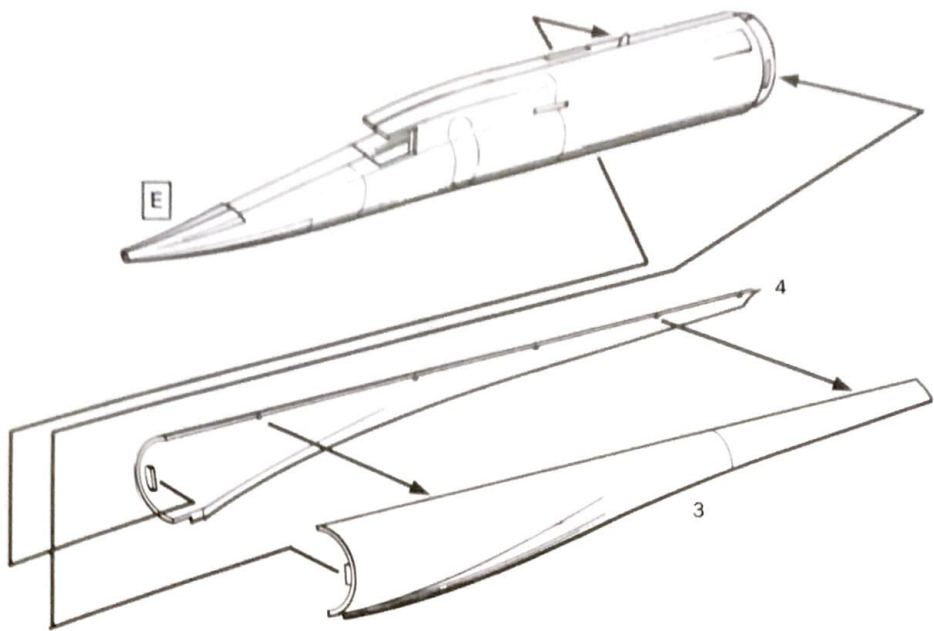
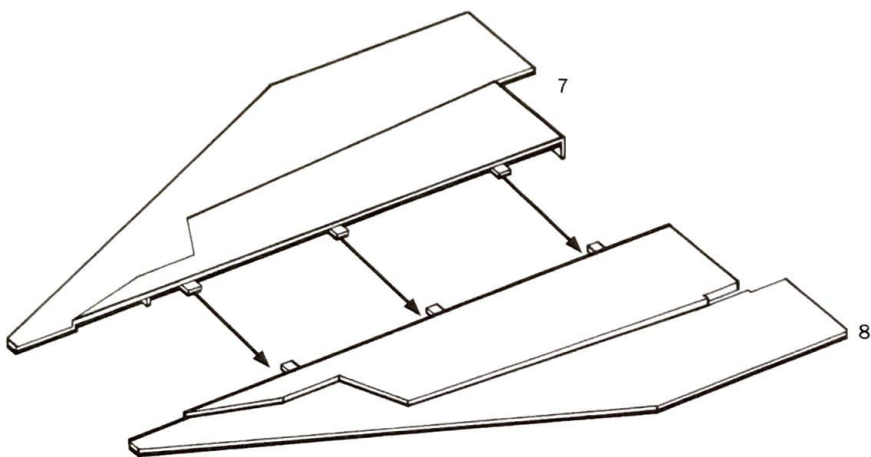
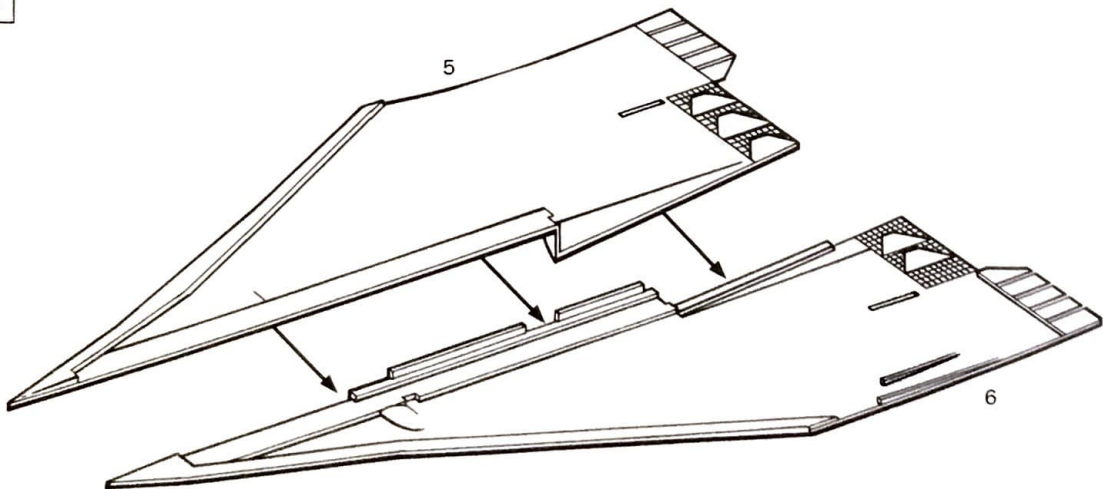
**4****F****5****G****6****H**

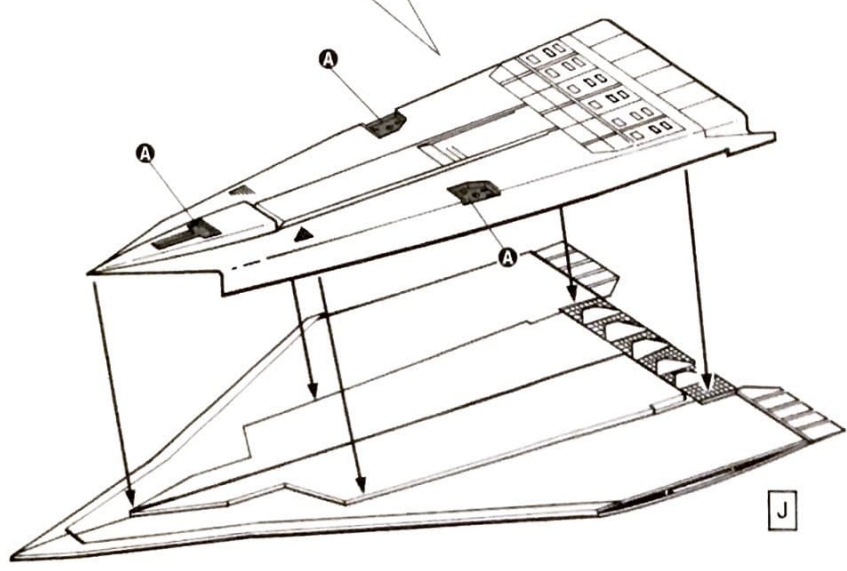
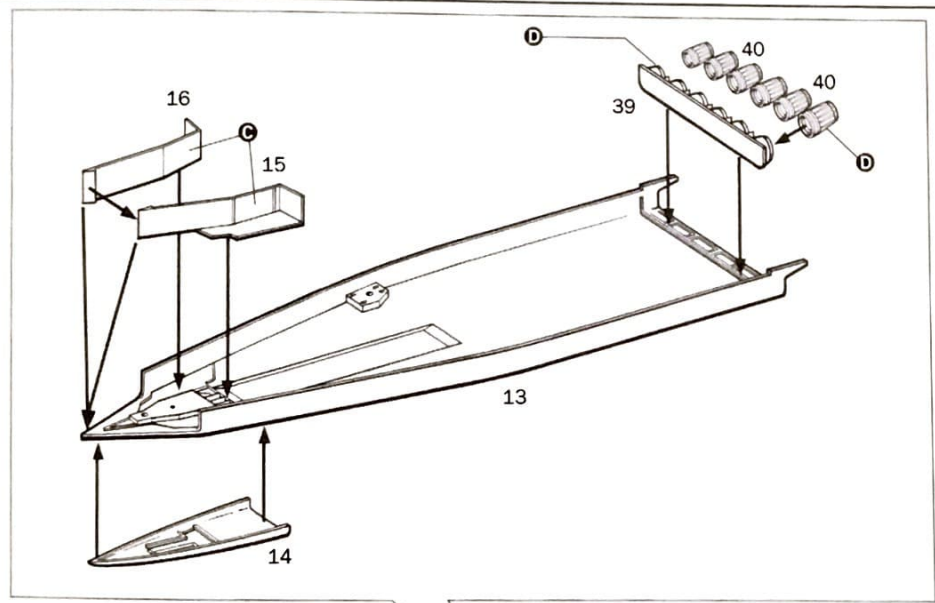
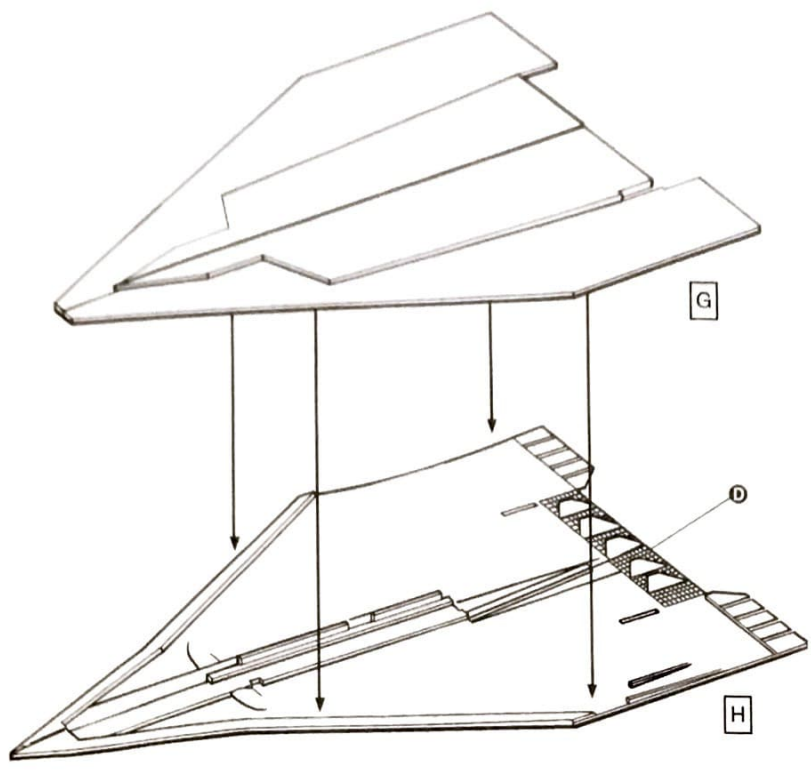

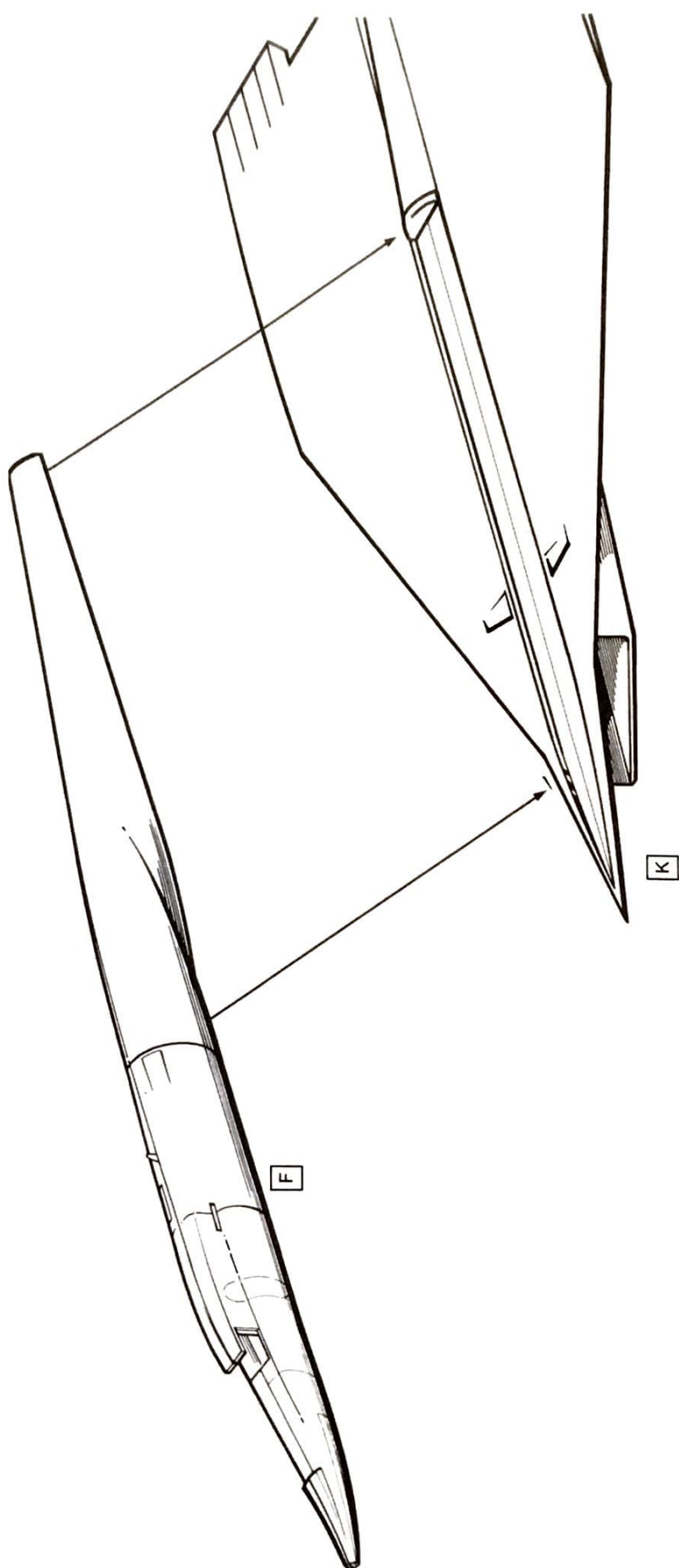

L1

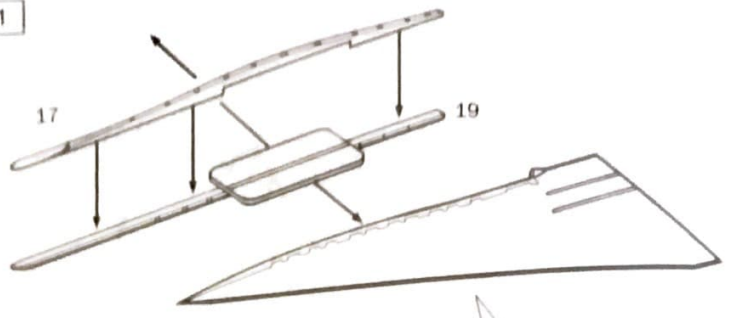

L2

ALTERNATIVE

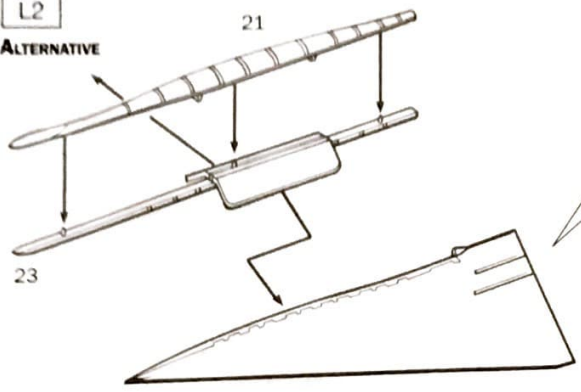

11

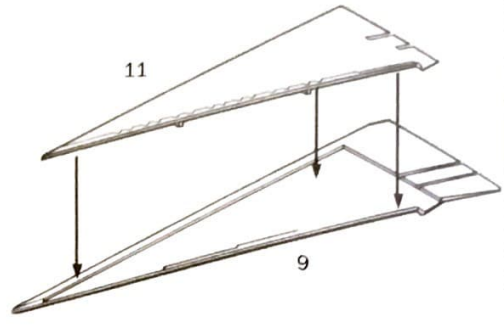

23

M1

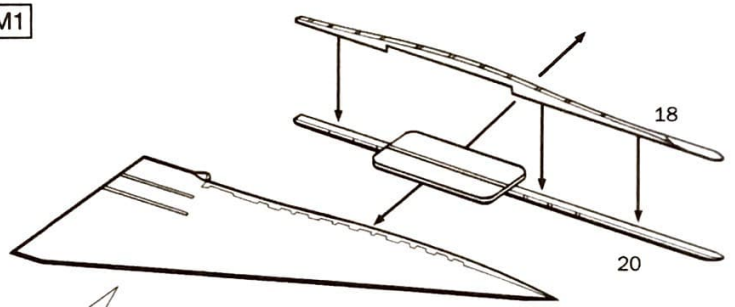

11

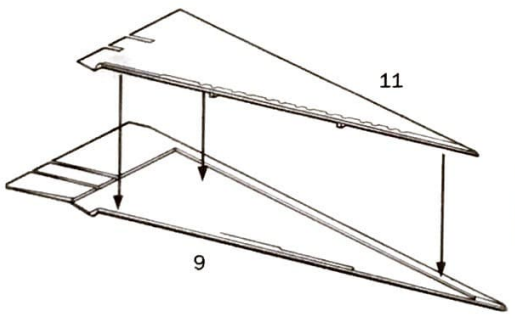

M2

ALTERNATIVE

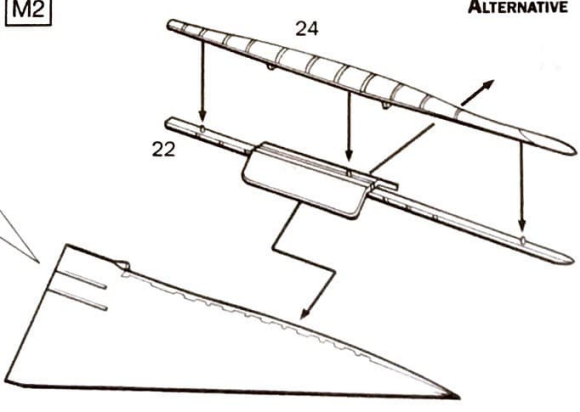

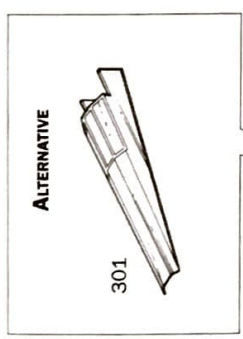
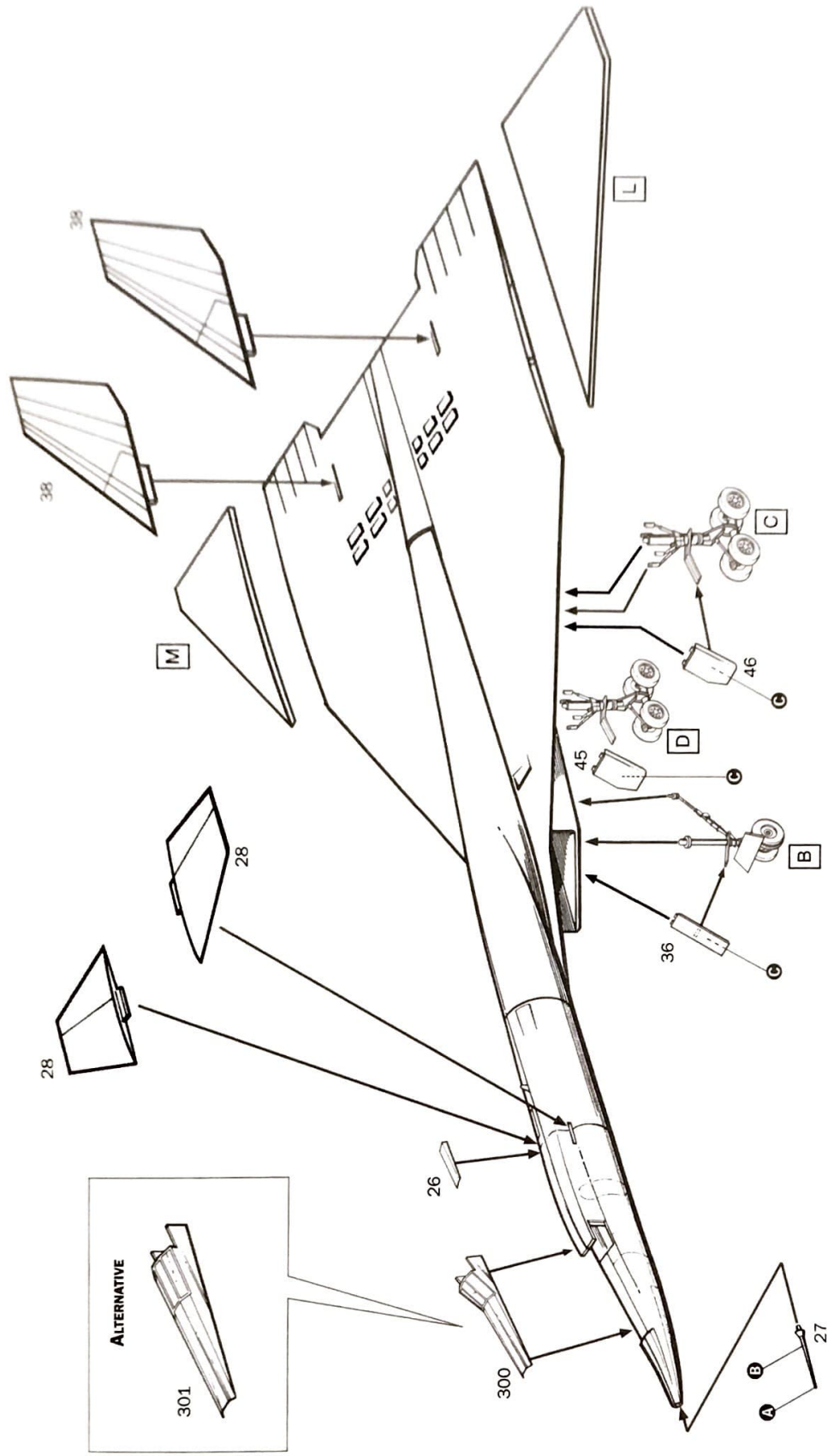

For a perfect application of the decals, we suggest using Model Master products 2145 or 2146.  
 Per una perfetta applicazione delle decals, si consiglia l'uso dei prodotti Model Master 2145 oppure 2146.  
 Für eine perfekte anbringung der decals wird die verwendung von Model Master no. 2145 oder 2146 empfohlen.  
 Pour une pose parfaite des decals, nous vous recommandons l'utilisation des produits à decals Model Master réf. 2145 ou 2146.  
 Voor het perfect aanbrengen van transfers, adviseren wij gebruik te maken van de Model Master producten 2145 of 2146.  
 Para facilitar la colocacion de las calcas y conseguir un resultado perfecto, sugerimos el uso de los productos 2145 o 2146 de Model Master.

Indicazioni per l'applicazione delle decalcomanie. Ritagliare le decalcomanie soppicando dal foglio, immergerle in un bicchiere di acqua pulita per circa 10", metterle in posizione sul modello e farle scivolare dalla carta per una migliore aderenza comprimerle con una pezzolina pulita.  
 Direction for applying the decals: cut the required decals out of the sheet; dip the into a glass of clean water for about 10", position the decals on the kit, letting them slide from the paper. For a better adhesion, press them by means of a clean rag.  
 Plazamiento de decalcomanías: cortar las decalcomanías eligiendo las requeridas, sumergirlas en un recipiente de agua limpia durante 10", colocar las decalcomanías sobre el modelo, haciéndolas deslizar sobre el papel. Para una mejor adherencia, presionarlas con un trapito limpio.



Anweisungen für Abziehbilder-Anbringung. Die benötigten Abziehbilder vom Blatt abschneiden, in ein Glas reines Wasser für etwa 10" eintauchen, auf das Modell legen und dann vom Papierbogen abheben. Um eine bessere Haftung zu erzielen, die Abziehbilder mit einem reinen Tuch andrücken.  
 Instruction pour l'application des décalcomanies. Couper les décalcomanies choisies et les plonger environ 10" dans un peu d'eau propre. Les placer sur le modèle en les faisant glisser de leur feuille et presser avec un morceau de chiffon pour éliminer les bulles d'air.  
 Instrucciones Para la aplicación de las calcomanías. Cortar las requeridas, sumergirlas en un recipiente de agua limpia durante 10", colocar las calcomanías sobre el modelo, haciéndolas deslizar sobre el papel. Para una mejor adherencia, presionarlas con un trapito limpio.

Transfers: knip het benodigde deel uit, dempel et ca. 10" onder water, oort het transfer tegen het model en schuif het vanaf het papier op zijn plaats. Met een schoon doekje aandrukken.

Указания по приклеиванию декалей. Отрежьте нужную вам часть декалей от общего листа, погрузите ее на 10 минут в чистую воду, затем, выжав лишнюю воду, прижмите декаль к поверхности модели, сдвигая ее с бумаги. Для лучшего приклеивания промокните декаль чистой тряпчатой основой.



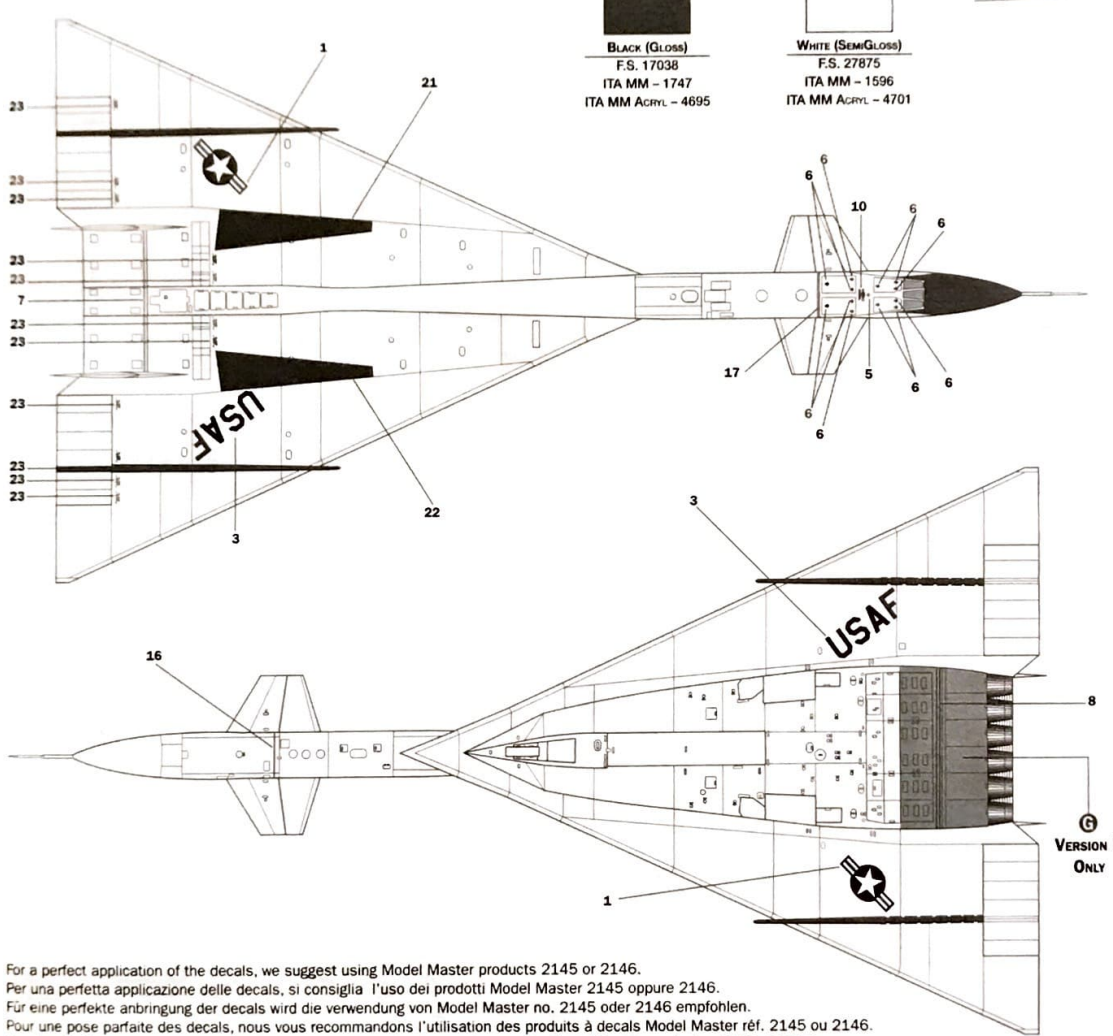
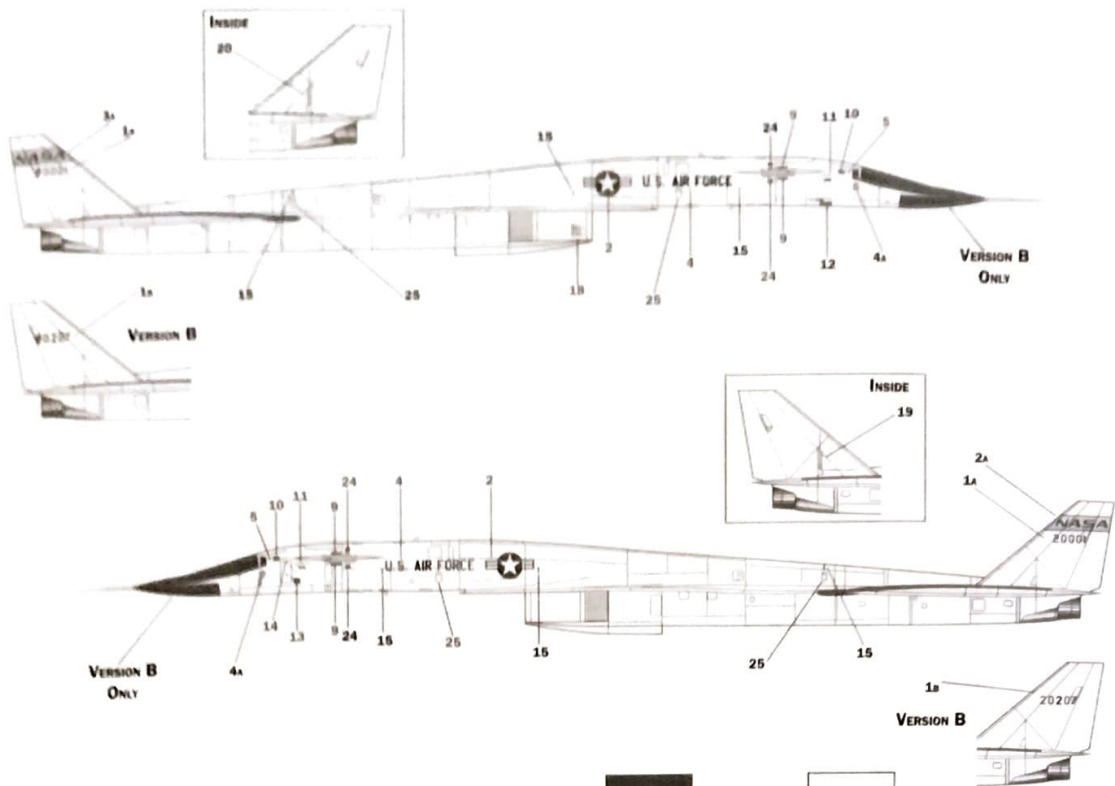

For a perfect application of the decals, we suggest using Model Master products 2145 or 2146.  
 Per una perfetta applicazione delle decalci, si consiglia l'uso dei prodotti Model Master 2145 oppure 2146.  
 Für eine perfekte anbringung der decalci wird die verwendung von Model Master no. 2145 oder 2146 empfohlen.  
 Pour une pose parfaite des decalci, nous vous recommandons l'utilisation des produits à decalci Model Master réf. 2145 ou 2146.  
 Voor het perfect aantbrengen van transfers, adviseren wij gebruik te maken van de Model Master producten 2145 of 2146.  
 Para facilitar la colocación de las calcas y conseguir un resultado perfecto, sugerimos el uso de los productos 2145 o 2146 de Model Master.

Istruzioni per l'applicazione delle decalcomanie Ritagliare le decalcomanie occorrenti dal foglio, immergerle in un bicchiere di acqua pulita per circa 10", metterle in posizione sul modello e farle scivolare dalla carta: per una migliore adesione comprimerle con una pezzuola pulita.  
 Direction for applying the decals: cut the required decals out of the sheet, dip the into a glass of clean water for about 10"; position the decals on the kit, letting them slide from the paper. For a better adhesion, press them by means of a clean rag.



Anweisungen für Abziehbilder-Anbringung: Die benötigten Abziehbilder vom Blatt abheben, in ein Glas reines Wasser für etwa 10" eintauchen, auf das Modell legen und dann vom Papierbogen abheben. Um eine bessere Haftung zu erzielen, die Abziehbilder mit einem sauberen Tuch andrücken.  
 Instrucción para la aplicación de las calcomanías: Cortar las requeridas, sumergirlas en un recipiente de agua limpia durante 10", colocar las calcomanías sobre el modelo, haciéndolas deslizar sobre el papel. Para una mejor adhesión, presionarlas con un trapito limpio.

Transfers: knip het benodigde deel uit, dempel et ca. 10" onder water; oudt het transfer tegen het model en schuif het vanaf het papier op zijn plaats. Met een schoon doekje aandrukken.

Plasättning av decalier klipp ut den decal som skall användas och doppa den i ett glas vatten under en 10". Sätt decalen på plats på modellen och låt den sakta glida av pappret. För att den skall sitta ordentligt, tryck till med en torr duk.

Указания по приклеиванию декалей: Отрежьте нужную вам часть декалей от общего листа, погрузите ее на 1/2 минуты в чистую воду. Затем, выдержав минуту, поднимите ее на поверхность, приподняв угол обложиванием, сдвинув ее по бумажке основы. Для лучшего прилипания промажьте декалей чистой тряпочкой.



**ITALERI S.P.A.**

**ITALERI S.P.A.**  
Via Pradazzo, 6/B - 40012 CALDERARA DI RENO (BO)  
ITALY

**ITALERI S.P.A.**

**ITALERI S.P.A.**  
Via Pradazzo, 6/B - 40012 CALDERARA DI RENO (BO)  
ITALY

**ITALERI S.P.A.**

**ITALERI S.P.A.**  
Via Pradazzo, 6/B - 40012 CALDERARA DI RENO (BO)  
ITALY

**ITALERI S.P.A.**

**ITALERI S.P.A.**  
Kundendienst für Deutschland:  
Gebr. FALLER GmbH 78148 Göttingen

**ITALERI S.P.A.**

**ITALERI S.P.A.**  
Via Pradazzo, 6/B - 40012 CALDERARA DI RENO (BO)  
ITALY

**ITALERI S.P.A.**

**ITALERI S.P.A.**  
Via Pradazzo, 6/B - 40012 CALDERARA DI RENO (BO)  
ITALY

**ITALERI S.P.A.**  
Via Pradazzo, 6/B - 40012 CALDERARA DI RENO (BO)  
ITALY

**ITALERI S.P.A.**

**ITALERI S.P.A.**  
Via Pradazzo, 6/B - 40012 CALDERARA DI RENO (BO)  
ITALY

**ITALERI S.P.A.**

**ITALERI S.P.A.**  
Via Pradazzo, 6/B - 40012 CALDERARA DI RENO (BO)  
ITALY

**ITALERI S.P.A.**

**ITALERI S.P.A.**  
Via Pradazzo, 6/B - 40012 CALDERARA DI RENO (BO)  
ITALY

**ITALERI S.P.A.**

**ITALERI S.P.A.**  
Via Pradazzo, 6/B - 40012 CALDERARA DI RENO (BO)  
ITALY

**ITALERI S.P.A.**

**ITALERI S.P.A.**  
Via Pradazzo, 6/B - 40012 CALDERARA DI RENO (BO)  
ITALY

**ITALERI S.P.A.**

**ITALERI S.P.A.**  
Via Pradazzo, 6/B - 40012 CALDERARA DI RENO (BO)  
ITALY

**ITALERI S.P.A.**

**ITALERI S.P.A.**  
Via Pradazzo, 6/B - 40012 CALDERARA DI RENO (BO)  
ITALY

**ITALERI S.P.A.**  
Via Pradazzo, 6/B - 40012 CALDERARA DI RENO (BO)  
ITALY

**ITALERI S.P.A.**  
Via Pradazzo, 6/B - 40012 CALDERARA DI RENO (BO)  
ITALY

**ITALERI S.P.A.**  
Via Pradazzo, 6/B - 40012 CALDERARA DI RENO (BO)  
ITALY

**ITALERI S.P.A.**  
Via Pradazzo, 6/B - 40012 CALDERARA DI RENO (BO)  
ITALY

**ITALERI S.P.A.**  
Via Pradazzo, 6/B - 40012 CALDERARA DI RENO (BO)  
ITALY

**ITALERI S.P.A.**  
Via Pradazzo, 6/B - 40012 CALDERARA DI RENO (BO)  
ITALY

**ITALERI S.P.A.**  
Via Pradazzo, 6/B - 40012 CALDERARA DI RENO (BO)  
ITALY

NAME, ADDRESS, TOWN, DEFECTIVE PARTS, PLACE OF PURCHASE, KIT No 1282 SCALE 1:72 - XB-70 VALKYRIE