

480120

TBM-1C

PRESIDENT GEORGE BUSH
CHICHI JIMA STRIKE BOMBER

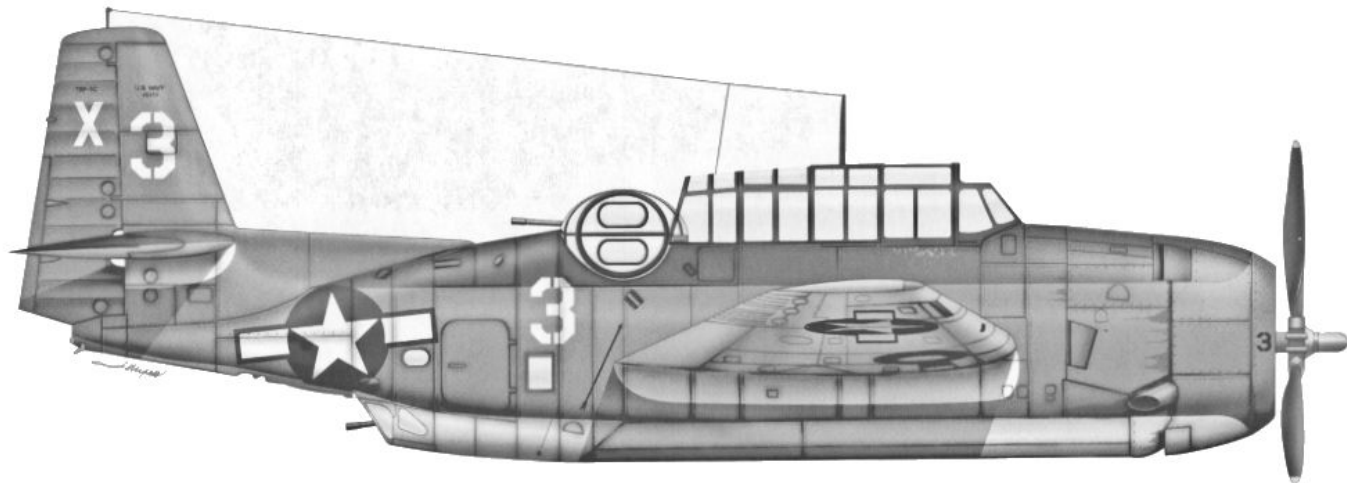

TBM-1C INSTRUCTIONS

The name 'Avenger' was in response to the Japanese attack on Pearl Harbor, but those who flew her lovingly called her 'turkey'. She was the largest single-engine aircraft to serve in WWII, but paradoxically, she often flew off of the smallest carriers. She dropped far more bombs than she did the torpedoes she was designed to launch, and in spite of a disastrous combat debut, she ultimately gave as good as she got.

She was the result of a call for design orders by the Bureau of Aeronautics for a carrier-based bomber which could fulfill a variety of missions: Torpedo and bombing attacks, strafing, scouting and smoke laying. The requirement called for an aircraft with a maximum speed of 300 MPH (482 km/h), a maximum range of over 1000 miles (1609km), and a maximum ceiling of 30,000 feet (9144m). Additional requirements included a maximum carrier take-off distance of 325 feet (99m, with wind across the bow), and an internal weapons bay.

The design was awarded to Grumman, whose prototype not only bristled with armament, but also carried the innovative "Sto-Wing," which had been recently introduced on Grumman's stubby little F4F-3 Wildcat. This design was the brainchild of Roy Grumman, who created the concept of wings folding backwards along the fuselage by using an eraser and two paperclips.

She was ordered into production in December 1940 with the first delivery being made in January 1942. Grumman was producing 60 Avengers a month by mid-1942 when the Navy required an increased production. The need was met by adding the Eastern Aircraft Division of General Motors to the manufacturing program. These were identical to the Avengers produced by Grumman, but were designated 'TBM.' By the end of 1943, Eastern Aircraft was the sole producer of Avengers. Over 7500 Avengers had been produced by VJ day, of which over 100 samples survive to this day.

The end of WWII did not end the fight of the Turkey. Companies in the western United States and the US Forestry Service employed surplus Avengers as aerial tankers. Many of these aircraft were converted to single-seaters, and modified to carry heavy loads of flame retardant. By the 1970s, the Avenger had been replaced by more advanced multi-engine tankers, but as late as the late 1990s, Avengers still served as fire-bombers and sprayers in Canada.

She is, indeed, a paradox. She started her career destroying enemy targets, and ended it extinguishing fires that were destroying the countryside. Truly, her greatest asset was her versatility.

IMPORTANT



We strongly recommend that you review this instruction booklet carefully, studying each step of the assembly process thoroughly before starting construction. There are a lot of small parts that require extra care in handling to avoid any damage. We also recommend that you paint as many components as possible BEFORE assembly, as many will be inaccessible as construction progresses.

You have a choice of two distinctly different and unique Avengers to model: the TBM-1C of the 41st President of the United States, George H. W. Bush, as he flew with VT-51 off the USS San Jacinto (CVL-30) on 2 September 1944, and "Plonky," 30 Squadron, RNZAF. The planes are identical in every way, except for decals.

RECOMMENDED PAINTS:

In order to help you paint your model correctly, we have included a list of color recommendations. These colors are cross-referenced to the Federal Standard (FS) numbers wherever possible. Many model paint companies match their products to this system, and you may choose to match your favorite paint to these numbers. Your local hobby retailer can be of assistance in helping you select the proper paint for this kit, or you may consult the listing of paints on the painting guide.

Separation of
Interior Colors:
Light Gray
Interior Green

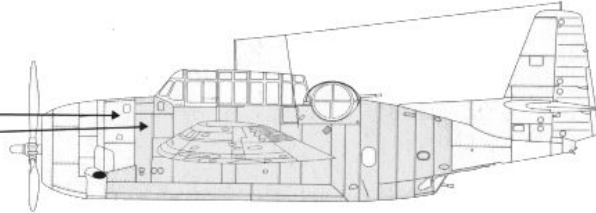

Model Paint Reference Chart*

| | Federal Standard | Model Master | Model Master Acrylic | Humbrol | Gunze Sangyo Aqueous | Gunze Sangyo Mr. Color | Tamiya | Polly S |
|-----------------|------------------|--------------|----------------------|---------|----------------------|------------------------|--------|---------|
| Flat Black | 37038 | 1749 | 5149 | 33 | 12 | 33 | XF1 | 10 |
| Flat White | 37875 | 1768 | 5168 | 34 | 11 | 62 | XF2 | 11 |
| Aluminum | 17178 | 1781 | 5181 | 11 | 8 | 218 | XF16 | 1995 |
| Olive Drab | 34087 | 1711 | 5111 | 155 | 304 | 304 | XF58 | 850 |
| Neutral Gray | 36270 | 1725 | 5125 | 176 | 306 | 306 | XF20 | 809 |
| Zinc Chromate | 34227 | 1734 | 5134 | 120 | 312 | 312 | XF4 | 802 |
| Insignia Yellow | 33538 | 1708 | 5108 | 154 | 329 | 329 | XF3 | 40 |
| Gloss Red | 11136 | 2178 | 5318 | 19 | 3 | 3 | X7 | n/a |
| Gloss Green | 14187 | n/a | n/a | 2 | 26 | 66 | X5 | n/a |
| Gloss Orange | 12197 | 2731 | n/a | 18 | 14 | 85 | X6 | n/a |
| Gun Metal | n/a | 1423 | 5195 | 53 | 18 | 214 | X10 | 1999 |
| Burnt Metal | n/a | 1415 | 5169 | n/a | 76 | 61 | n/a | 1997 |

*This chart is provided only as an aid to the modeler and is the closest match possible from each paint manufacturer at the time of printing

STEP 1-COCKPIT/BOMB BAY ASSEMBLY

The cockpit will benefit from having the various pieces painted before they are glued into position. There are many small parts that will be hard to get to later.

PAINT INSTRUCTIONS:

Paint instructions:

1 & 2 -- See previous page for interior breakdown
30 & 31 -- Flat Black with Aluminum and Flat White Details

27 -- Interior Green with Black Handle and Tan Boot

28 -- Interior Green with Leather Arm Rests

29 -- Interior Green with Leather Head Rest

25 -- Interior Green with Flat Black Auto Pilot Boxes and Yellow Oxygen Bottle.

19, 84 L & R, 85 L & R, 86 L & R, 117 - Interior Green

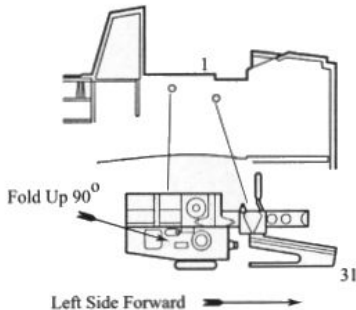
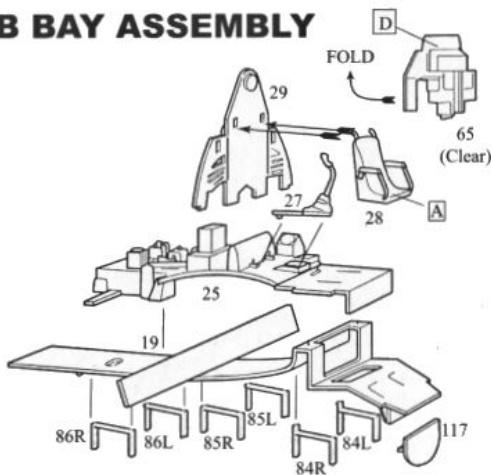
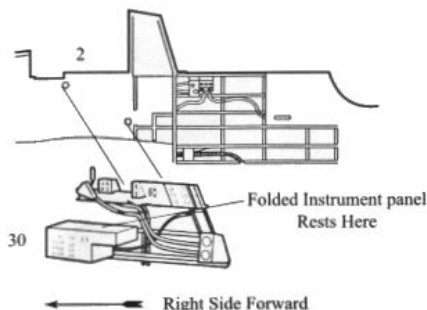

- ▲ 1. Glue the control stick (27) to the cockpit floor (25).
- ▲ 2. Glue the cockpit tower bulkhead (29) to the cockpit floor.
- ▲ 3. Apply the pilot's seatbelt decal (A) to the pilot's seat (31). You may elect to leave the decal on the paper for a more realistic effect, or you may also elect to use your own technique. Now, glue the pilot's seat to the cockpit floor and to the cockpit tower bulkhead.
- ▲ 4. Carefully bend the left cockpit console (31) up 90 degrees, which will bring the trim wheel to a vertical position. Glue the console to the left fuselage half.
- ▲ 5. Glue the right cockpit console (30) to the right fuselage half.
- ▲ 6. Carefully fold the electrical panel on the right side of the instrument panel (65) as shown. This panel will rest on top of the right cockpit console when the fuselage halves are joined. You might find it easier to cut this panel off and glue it directly to the box on the right of the console being sure to center it on the surface. After painting the instrument panel, and applying the decals (D) to the rear, glue the instrument panel to the cockpit floor.
- ▲ 7. Glue the cockpit floor assembly to the bomb bay roof. **NOTE:** If you plan to build your kit with the bomb bay doors closed, there will be no need to install any of the bomb racks.
- ▲ 8. Starting at the front, glue the front bomb racks (84L&R), the center bomb racks (85L&R), and the rear bomb racks (86L&R) to the bomb bay roof. The racks should have their flat surfaces facing outboard.
- ▲ 9. Glue the bomb bay bulkhead (117) to the lower front of the bomb bay roof with the ribs pointing rearward.
- ▲ 10. You may elect to install the ordnance at this point in the assembly process. Once the cockpit assembly is complete, and placed into the fuselage, it will become crowded and the weapons will become more difficult to install. Refer to step eight for ordnance assembly instructions.

STEP 2-FUSELAGE CENTER

PAINT INSTRUCTIONS:

33, 58, 64 Interior Green

32, 26 Interior Green with Flat Black radio gear

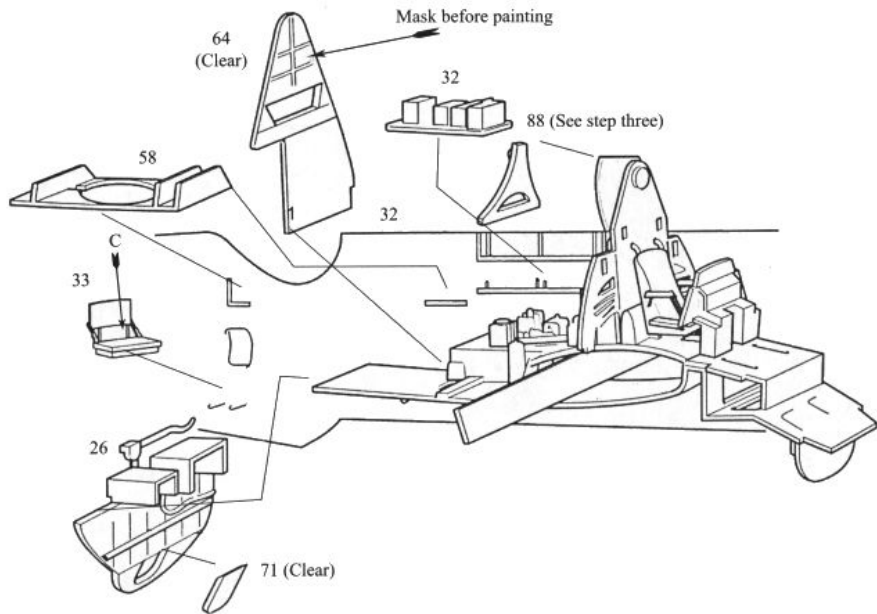

- ▲ 11. Glue the cockpit assembly to the left fuselage half, sliding the wing spar through the opening in the fuselage. Check the alignment while the glue dries to ensure everything is straight. There should be no interferences.
- ▲ 12. Mask and paint the interior bulkhead (64) as indicated. Glue the interior bulkhead to the rear edge of the cockpit floor and the left fuselage half.
NOTE: *The clear parts, with the exception of the turret halves, may be installed using white glue, clear gloss acrylic, or a clear gloss top coat to avoid smearing.*
- ▲ 13. Carefully glue the bomb bay window (71) into the rear bomb bay bulkhead. Glue the bulkhead to the rear of the bomb bay roof and the left fuselage half.
- ▲ 14. Apply the crew seatbelt decal (C) to the crew seat (33). As with the pilot's seat belt, you may elect to leave the decal on the paper for a more realistic effect, or you may also elect to use your own technique. Now glue the crew's seat to the locator pins on the left fuselage half, facing forward. We recommend the use of CA (cyanoacrylate) cement to glue this seat, as the locators are in scale, therefore very small.
- ▲ 15. Glue the turret base (58) into the locators in the left fuselage half.
- ▲ 16. Finally, glue the radio equipment (32) to the front interior bulkhead and the left fuselage half. The three tabs on the left side fit into the locators on the fuselage half as shown.

STEP 3-REAR FUSELAGE

PAINT INSTRUCTIONS:

- 88 - Bronze Green
- 36, 37 - Interior Green
- 34 - Aluminum
- 35 - Gun Metal with Brass Cartridges
- 22 - Black with 1/8" white stripes
- 38L&R, 39 - Aircraft Underside Color
- 78 - Framing to Match Underside Color

▲ 17. Carefully align and glue the flare chutes (34) to the forward side of the ammunition box bulkhead (36). When properly aligned, the tubes should protrude through the bulkhead and point down slightly toward the rear of the fuselage. Glue this assembly to the right fuselage half against the forward edge of the forward locator rib and behind the two locating ribs.

▲ 18. Glue the tail wheel bulkhead (37) into the right fuselage half against the rear edge of the rearmost locator rib.

▲ 19. Glue the arresting hook (22) to one of the two locating holes in the right fuselage half. The hook may be extended out of the rear of the aircraft by placing it in the optional rear locator. If you elect to place it in the rear position, clip 1/16th of an inch off of the mounting pin on the hook before gluing it into place. In either case, make sure the hook extends through the opening in the tail.

At this point you will want to check all of the alignments. Before moving on to the next assembly, you will need to know which of the decal options you are going to use. The Avengers of VT (N)-90 had the tunnel gun removed, and therefore, that part (35) may be omitted from the construction process.

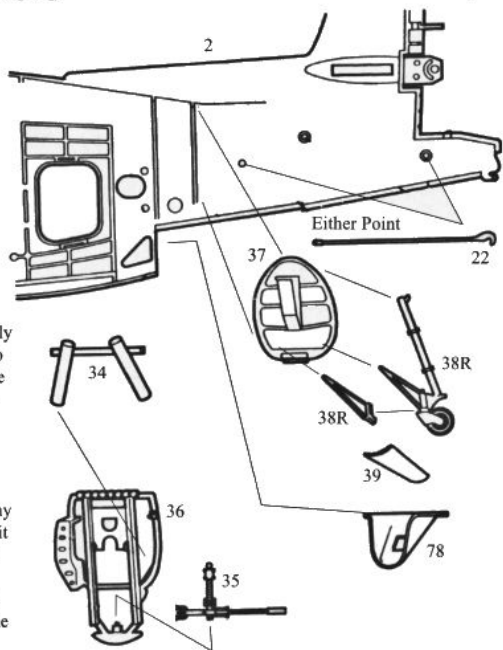

▲ 20. Carefully bend the ammunition belt upward 90 degrees on the ventral machine gun so that it will connect to the ammunition bulkhead. The gun is now glued to the locator pin on the ammunition box bulkhead and the ammunition box. Be careful so as not to accidentally break off the barrel.

▲ 21. Test fit the fuselage halves. If you left the electrical panel attached to the instrument panel in step one, ensure that it is pulled up and rests correctly on the right cockpit console as described. There should be no interference. When you are satisfied that everything is working as advertised, glue the fuselage halves together.

▲ 22. Glue the cockpit tower back (88) shown in the step two drawing, to the rear of the cockpit tower. The round device on this part is a formation bombing signal light.

▲ 23. Apply masks, and then glue the ventral gun window (78) to the bottom/rear of the fuselage after carefully locating the ventral gun through the opening.

▲ 24. Glue the tail wheel brace (38R) to the tail wheel strut (38L) and glue the assembly to the locators on the tail wheel bulkhead.

▲ 25. The tail wheel door may be glued to the tail wheel assembly at this point, or you may place it after the final painting.

STEP 4-ENGINE/TAIL SURFACES

PAINT INSTRUCTIONS:

- 7, 8 - Gun Metal with Black Push Rods and Plug Wires
- 11 - As instructed in the final assembly
- 3, 4, 6 interiors, 9 - Light Gray
- 5 - Burnt Metal

- ▲ 26. Glue the rear cylinder row (8) to the front cylinder row (7). The front row should have a jug pointed to the six o'clock position.
- ▲ 27. Place the propeller shaft (10) onto the assembled engine and glue the crankcase front cover (9) to the front cylinder row, trapping the shaft between the crankcase and the front row. The prop governor on the crankcase front cover should point to the twelve o'clock position. Be careful not to let any glue come into contact with the propeller shaft.
- ▲ 28. The propeller (11) should be added at the end of the assembly process (Step 8) by carefully pushing it onto the propeller shaft. Decals are also to be added during the finishing process.
- ▲ 29. Glue the engine assembly to the engine mount on the front of the fuselage.
- ▲ 30. Glue the cowl halves (3&4) together, followed by adding the cowl ring (6).
- ▲ 31. Add the cowl assembly to the fuselage. The exhaust stacks can be added at this point, or after the final assembly. They should point slightly downward.

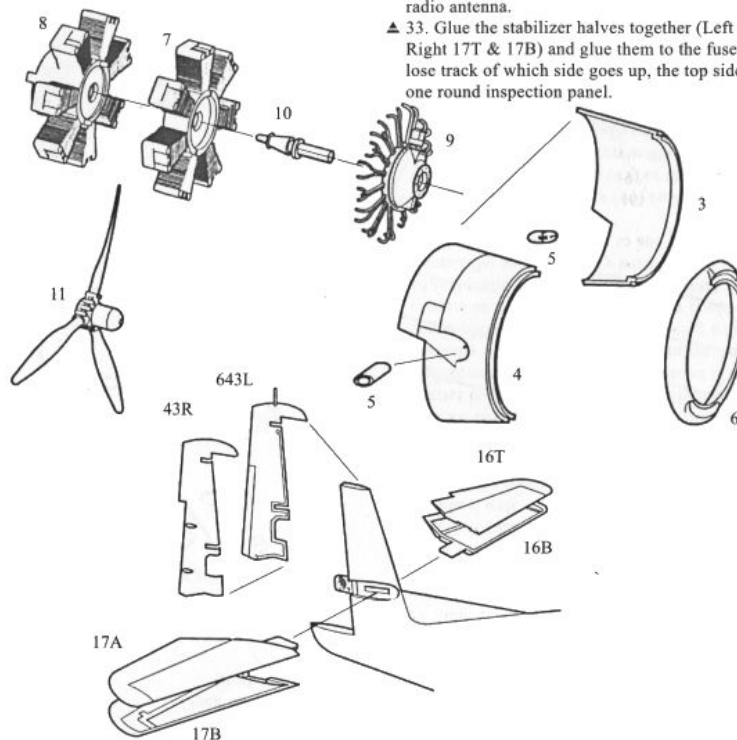

- ▲ 32. Glue the left rudder halves (43L&R) together. We recommend adding the assembled rudder to the fuselage at the end of assembly to avoid breaking the delicate radio antenna.
- ▲ 33. Glue the stabilizer halves together (Left 16T & 16B, Right 17T & 17B) and glue them to the fuselage. If you lose track of which side goes up, the top sides have only one round inspection panel.

STEP 6-BOMB BAY DOORS

PAINT INSTRUCTIONS:

23 L&R (Interiors), 24 F&R -- Interior Green

- ▲ 44. If you wish to assemble your model with the bomb bay doors closed, simply glue the doors (23L & 23R) to the appropriate fuselage halves. If you are building your kit with the doors open, and have not yet installed the ordnance, this is your last chance. The installed bomb bay doors will severely restrict access to the bomb bay. Consult step eight for ordnance assembly instructions.
- ▲ 45. Carefully remove the front bomb bay hinge (24F) and the rear bomb bay hinge (24R) from the sprue. If you lose track, of which is which, the rearward hinge has a long vertical actuating arm.
- ▲ 46. Carefully cut and fold the bomb bay doors (23L&R) inward along the groove in the center of the door. Glue the hinges in the forward and rearward positions. The round, hydraulic reservoirs on the hinges face away from the interior of the bomb bay. The hinges will set the proper angle of the doors.
- ▲ 47. Allow the parts to dry thoroughly, then glue the hinges up into the bomb bay until they rest on the bomb bay roof at the front and rear of the bomb bay bulkheads. The tops of the doors should rest against the sides of the fuselage.

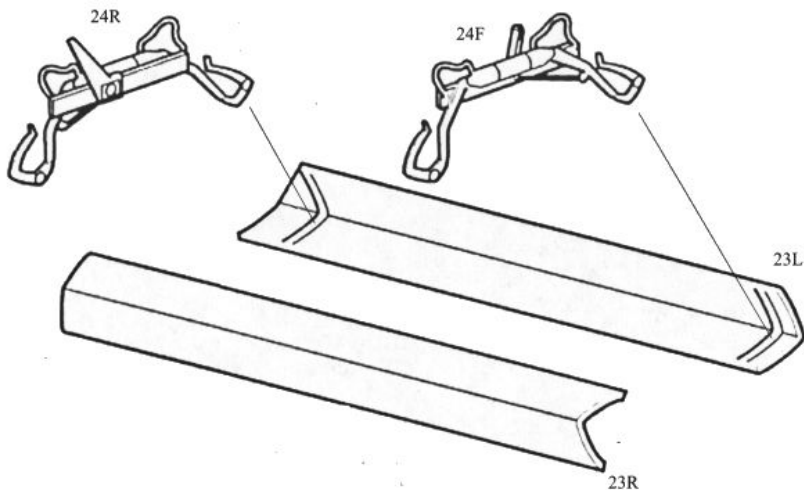

STEP 7-CLEAR PARTS

PAINT INSTRUCTIONS

81--Flat Black

67, 68 L&R, 69, 72, 73, 74, 75, 76, 77, 83 L&R

-- Framing to match exterior color

50 -- To Match Upper Exterior Surface

- ▲ 48. Glue the gun sight (81) to the top of the cowl and the instrument panel.
- ▲ 49. Using the non-crazing adhesive of your choice, glue the windshield (67) and the main canopy (69) to the fuselage.
- ▲ 50. Glue the radio antenna (50) to the top of the main canopy. The forward end of this piece glues to the windshield.
- ▲ 51. The sliding pilot's windows (68L&R) may be placed in the open or closed position. Each side opens independently, and may be positioned accordingly. If you lose track of which is left and which is right, the left panel has a vertical frame support
- ▲ 52. Glue the ventral windows (76- L, 77,-R) to the appropriate fuselage halves.
- ▲ 53. Glue the left forward window (72) and the left rear window (72) to the left fuselage half.
- ▲ 54. Glue the right forward window (75) and the

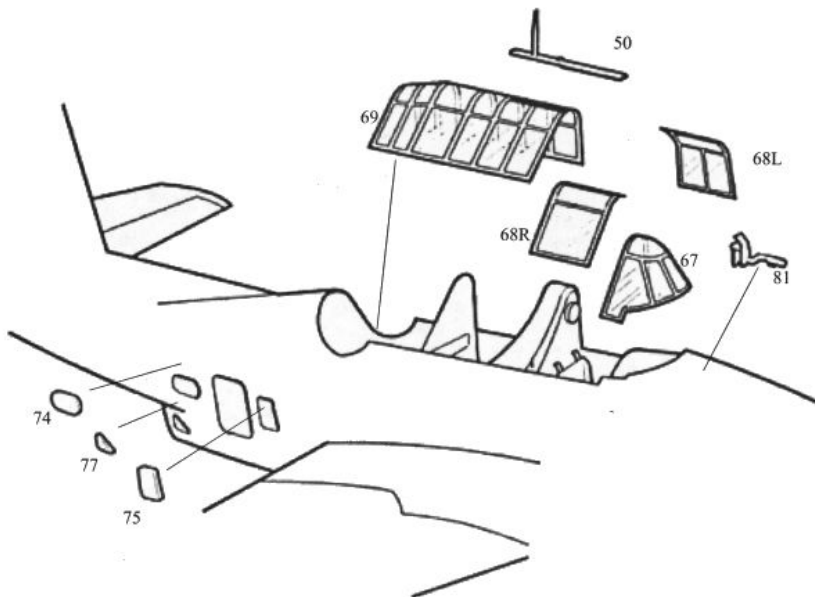

STEP 8-TURRET

PAINT INSTRUCTIONS:

55 - Interior Green, Gun Metal Machine Gun

54 - Interior Green with Brass Cartridges

20, 52, 56, 57, -- Interior Green

62, 63 -- Frame to Match Exterior

The parts in this assembly are delicate and designed to accurately represent the turret in the simplest manner. Take your time, and you will be rewarded with an in-scale, functional turret assembly. Be patient, test fit, allow ample drying time, and do not force the parts.

- ▲ 55. Glue the gun mount (55) to the turret/ammunition box.
- ▲ 56. Glue the turret armor glass (61) to the locator on the turret armor.
- ▲ 57. Apply the gunner's seat belt decal (B) to the turret gunner's seat. Again, you may elect to leave the decal on the paper for a more realistic effect, or you may also elect to use your own technique. Glue the seat to the ammunition box/gun assembly.
- ▲ 58. Glue the turret armor assembly to the front of the ammunition box/gun assembly and the gunner's seat. Check the alignment of the turret parts allow to dry thoroughly.
- ▲ 59. Apply the masks to the left and right turret halves (62&63). On a level surface, carefully glue the left turret half (62) to the right turret half (63) and allow thorough drying.

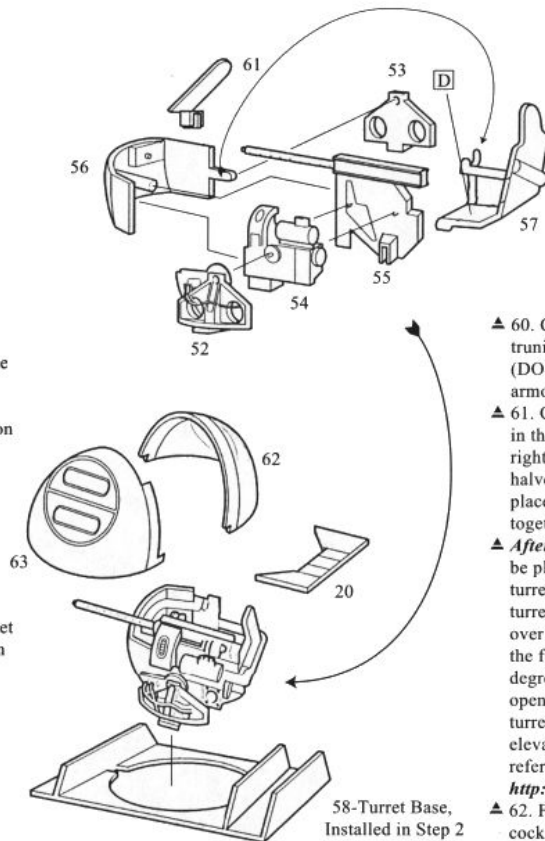

- ▲ 60. Carefully place (DO NOT GLUE) the gun side trunion (52) onto the ammunition box assembly. Place (DO NOT GLUE) the seat side trunion onto the turret armor. These pieces allow the gun assembly to elevate.
- ▲ 61. Carefully place the gun barrel through the opening in the clear turret assembly and gently slide the left and right side trunions up into the notches in the turret halves. PATIENCE! It will fit. Now, very carefully, place a small amount of glue where these parts come together.
- ▲ *After the turret assembly has thoroughly dried*, it may be placed into the fuselage, located and rotated into the turret base (installed in step 2). To do this, grasp the turret between your thumb and forefinger and position it over the turret opening. Hold the turret at 90 degrees to the fuselage length, and tipped forward about 45 degrees. The turret will now easily drop down into the opening. Tip the turret to horizontal and place it into the turret base. The turret will now rotate, and the gun will elevate. If there are questions about this process, reference the example on our web site, located at <http://www.accurate-miniatures.com>.
- ▲ 62. Finally, glue the cabin shelf (20) to the rear of the cockpit opening to secure the turret in place.

STEP 9-ORDNANCE & FINAL DETAILS

PAINT INSTRUCTIONS

115, 116-Olive Drab with Aluminum Fuse

12 (interior)-Interior Green

18-upper surface color with a silver tip

111, 112-Gun Metal

79L-Green

79R--Red

- ▲ 63. Assemble the 500-lb bombs by gluing the halves (106&107) together. Ordinarily, the bombs were carried in the rearward position.
- ▲ 66. The standard Navy bomb cart (96) may be displayed with or without ordnance.
- ▲ 75. Glue the crew entry door (21) to the right fuselage half. It may be installed either in the open or closed position.
- ▲ 76. Glue the Yagi radar mount (112) to the Yagi antenna (111). These antennas rotated outward slightly, and may be positioned accordingly.
NOTE: The right wing Yagi antenna should be installed AFTER the national insignia decal is placed.
- ▲ 77. Glue the pitot tube (18) to the left wing tip.
- ▲ 78. Glue the wing-tip navigation lights (79L&R) onto the wings. Remember: left-red, right-green. 79. You may now add the propeller (see step 4). The rudder assembly is also added at this time (also from step 4).

* Graffiti on bombs was a common practice during WWII, as such we have included decals #AS7 and AS8, which you may add to your ordnance at your whim.

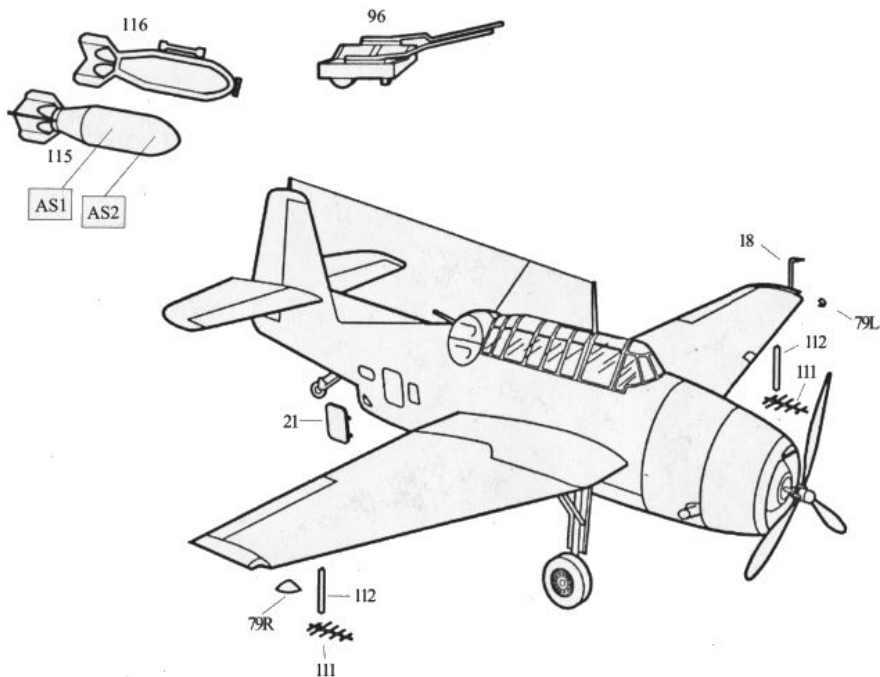

STENCIL PLACEMENT

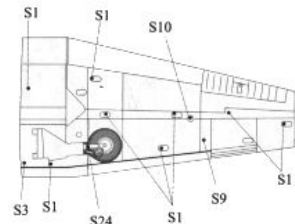
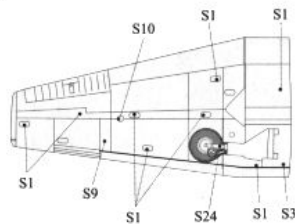
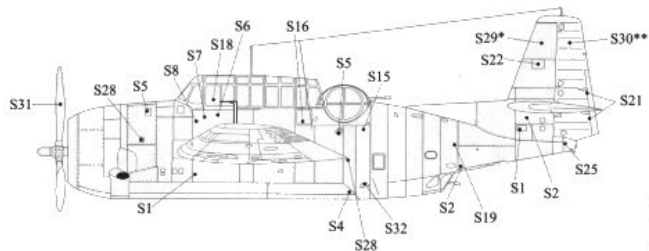
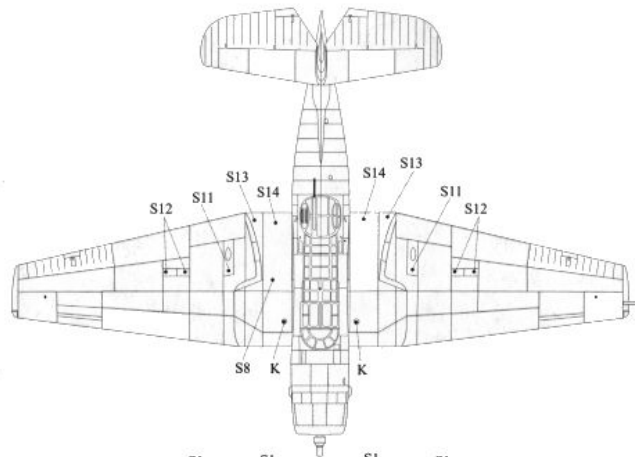
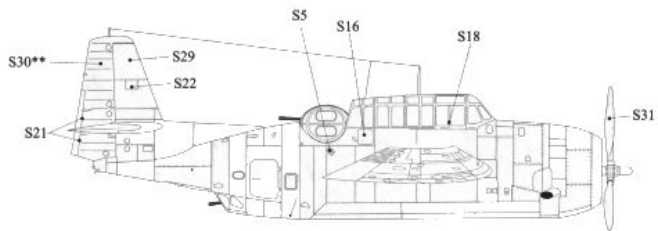

* S29A on "White X3,"
S29B on "White X2."

** S30A for the Bush Avenger

STEP 11a-DECAL PLACEMENT AND FINISHING

President George H. W. Bush, VT-51



Non-Specular Sea Blue (FS 35042)



Intermediate Blue (FS 35164)



Flat White (FS 37875)

"White X3" was the Avenger that Future President George H. W. Bush was flying when he was shot down over the island of Chichi Jima on 2 September 1944. Decals are included for "White X2," which Bush normally flew.

Decals number 9 & 10 are personal markings that were supposedly unique to "X2." There is no photographic evidence that these markings ever existed. In fact, the CO of VT-51 did not allow personal markings, citing security reasons. We have chosen to include these decals as options to give the modeler a little room for "artistic license." Be aware that the Accuracy Police will have your modeling hide if you choose to use them. You have been warned.

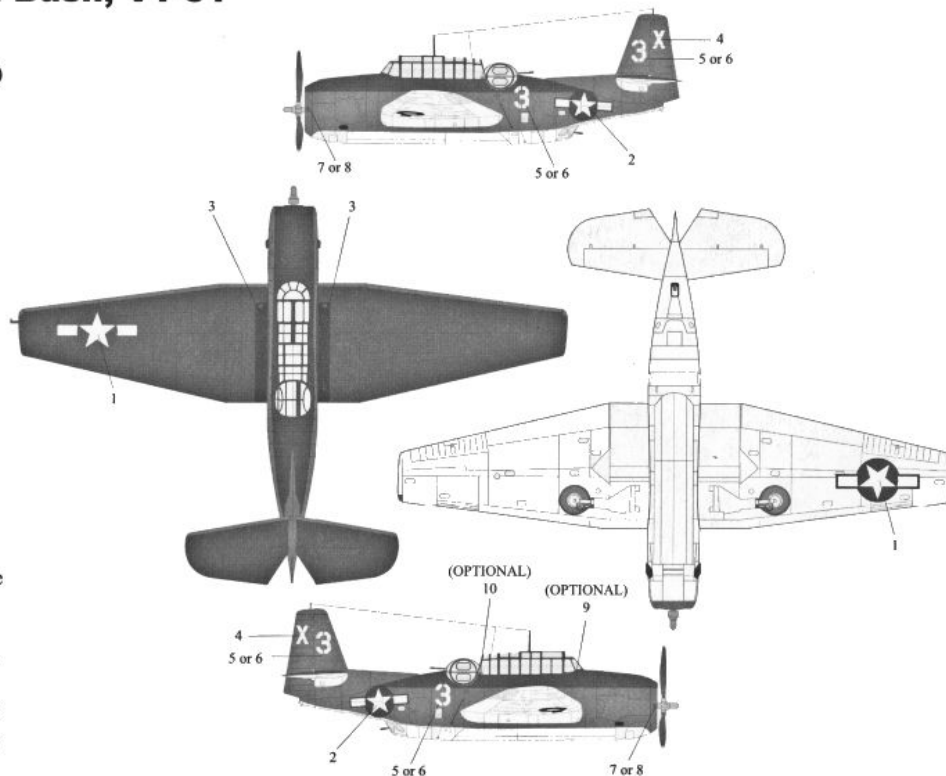

STEP 11b-DECAL PLACEMENT AND FINISHING

"Plonky," 30 Squadron, RNZAF

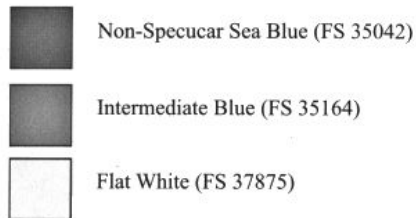

Flight Lieutenant Fred Ladd, the pilot of "Plonky," was a tea-totaler who could think of nothing more insulting than having beer poured all over oneself, hence the flying beer barrel with an open tap. This plane is identical in every way to the Avengers employed by the U.S. Navy and Marines, with the exception of markings. This plane was particularly heavily weathered, patched and scruffy owing to an eventful combat career.

