

SIYUR

IDF 1/4 TON 4x4 RECONNAISSANCE VEHICLE M38A1/CJ-5

The Jeep or Willys MB, produced by Willys-Overland, was a light military utility vehicle used widely by the Allies during WWII. With an impressive production figure of well over 600,000 units, through Lend Lease, this nimble little four wheel drive vehicle appeared in all theaters of the war. In 1952, Willys-Overland produced a successor, the Willys MD, which incorporated numerous upgrades including a strengthened chassis, longer wheelbase, redesigned radiator, front grill, and hood to accommodate an engine with higher output. The Willys MD saw action in Korea and Vietnam.

In 1920, the League of Nations mandated British administration of Palestine and the Jeep was introduced into the area by the British. After the end of WWII, a large migration of Jews settled in Palestine. With the development of the Zionist movement, the newly formed Jewish settlement began procuring arms and vehicles and thus the Willys MB entered the inventory of the Israeli Defense Force (IDF).

In 1965, the IDF purchased a series of CJ-5 (civilian version of the M38A1) with a variety of armament installations as well as some M606A2 (export version of the M38A1). They were deployed to the field soon after modifications were made according to the specifications listed by the IDF. These modifications consisted of a reconnaissance version of the CJ-5, SIYUR, which had a 7.62mm machine gun installed on a swivel base in front of the right front seat. Radio equipment was also installed in the SIYUR. An anti-armor version of the CJ-5, the TOLAR; to that of the American M38A1c, was equipped with an M40A1, 106mm recoilless rifle. Both variants participated in the 1967 Six Day War. The TOLAR was later replaced by the TOW anti-tank missile equipped CJ-5 ORLEV after the end of 1973 Yom Kippur War.

Text edited by John D. Miller, Ph.D,

Owner Model Paint Solutions.com

ウィリスオーバーランド社によって開発されたジープやウィリスMBは、第二次世界大戦中に連合国によって広く使用された軽量の小型軍用車両です。60万台を超える驚異的な生産数とレンドリース法により、この小型四輪駆動車は全ての戦場で目にする事が出来ました。ウィリスオーバーランド社は、1952年に後継モデルのM38A1(ウィリスMD)を発表しました。これには、シャーシの強化やホイールベースの延長、高出力エンジンに対応するためのラジエーターやフロントグリル、フードの再設計など、多くのアップグレードが施されました。このウィリスMDは後に韓国やベトナムの戦場で使用されました。

1920年、国際連盟はパレスチナの統治をイギリスに委託し、それによってパレスチナへウィリスジープが導入されました。第二次世界大戦後、多くの無国籍ユダヤ人がパレスチナへ移住しました。シオニズム運動(パレスチナにユダヤ人の国家を築くことを目指した運動。)の発展に伴い新たに形成されたユダヤ人の入植地では、世界中から武器や車両を購入することが出来るようになり、ウィリスMBもイスラエル国防軍に導入されました。

1965年、イスラエル国防軍は様々な種類の武器が取り付けられたCJ-5(M38A1の民間市販型)と、M606A2(M38A1の軍用輸出型)を購入しました。イスラエル国防軍に規定された仕様に従い改修が行われた後、戦場に投入されました。中でも、偵察任務を務めたCJ-5 SIYURは、副操縦席の前に7.62mm口径機関銃を設置、無線通信装置の設置といった改造が行われました。対装甲担当のCJ-5 TOLARは、アメリカ軍のM38A1Cと同様の構成で、後部にM40A1 106mm口径無反動砲が装備されました。両車は1967年の第三次中東戦争に参加し、TOLARは1973年の第四次中東戦争終結後、牽引対戦車ミサイルを搭載したCJ-5 OREVにその役目を引き継ぐこととなりました。

ウィリスMB(ウィリスMB)が盟軍在第二次世界大戦期間大量採用の軍用軽型車輻、透過租借法案及六十幾萬輛の龐大產量、使得各個戰場都能見到這種四輪驅動車的身影。1952年威利公司推出了後繼車款M38A1(Willys MD), 強化了底盤並加長軸距, 採用比MB更大功率的發動機, 為此重新設計水箱護罩與引擎蓋, 日後投入了韓國與越南的戰場中使用。

1920年國際聯盟委託英國管轄巴勒斯坦, 英國人也將威利吉普引進此處。二戰結束後大量無国籍猶太人移入巴勒斯坦, 隨著猶太復國運動的推進, 海外的猶太人也設法從世界各地採購武器和車輛, Willys MB自此也進入了以色列部隊之中。

1965年以色列國防軍訂購了一系列搭載各式武裝的CJ-5(M38A1的民間版), 與M606A2(M38A1的軍用外銷版), 經過了適應以色列需求的修改後運用於戰場。其中擔任偵察任務的CJ-5 Siyur在副駕駛前面安裝了一挺7.62mm口徑機槍, 並裝備了無線電通信設備。擔任反裝甲的任務的CJ-5 Tolar與美國M38A1c的配置相同, 車後方搭載了一門M40A1 106mm無後座力砲。這兩款車輻均參與了1967年的六日戰爭, 後者在1973年的贖罪日戰爭後, 陸續為配備拖式反戰車飛彈的CJ-5 Orev所取代。

PARTS LIST 零件表

(B) x1 AF35S17

(C) x1 AF35S17

(A) x1 AF35S17

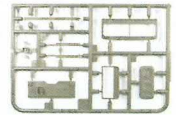
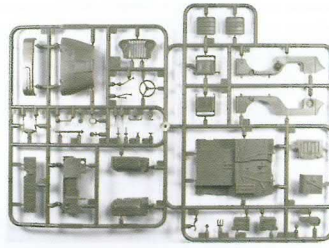
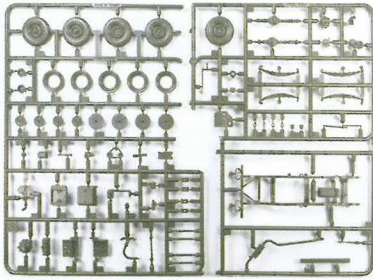

(K) x1 AF35S17

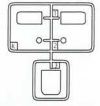

(D) x1 AF35S17



(E) x1 AF35S94

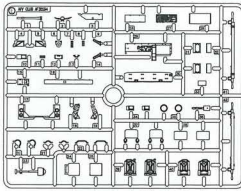

(U) x1 AF35267

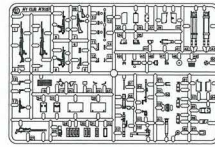

(GA) x1 AF35S94

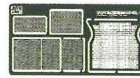

(J) x1 AF35S94



Instructions:

If for some reason, you are not fully satisfied or have questions concerning our product; Please use the form provide, and send it to our nearest representative or mail it directly to our office.

We will deal with that A.S.A.P.

限臺灣地區使用 For Taiwanese use only!



AF 35S94 零件補充申請表

申請人
姓名 地址 電話

- AF 35S17-A ——— NT\$ 160
- AF 35S17-B ——— NT\$ 140
- AF 35S17-C ——— NT\$ 100
- AF 35S17-D ——— NT\$ 100
- AF 35S17-K ——— NT\$ 50
- AF 35S94-E ——— NT\$ 260
- AF 35267-U ——— NT\$ 200
- AF 35S94-J ——— NT\$ 160
- AF 35S94-GA ——— NT\$ 200

+郵寄費 ——— NT\$ 80

(請填)總計NT\$ _____

零件補充原因:(請於□打√)

原包裝即 遺失或 毀損,
製作途中 遺失或 毀損,

其他原因 _____

總代理：戰鷹企業有限公司收本公司將儘速為您處理。
請將本表與該部品相同金額之郵政匯票一同寄至



AF 35S94 Parts Replacement Form

- AF 35S17-A
- AF 35S17-B
- AF 35S17-C
- AF 35S17-D
- AF 35S17-K
- AF 35S94-E
- AF 35267-U
- AF 35S94-J
- AF 35S94-GA

Reason for replacement: Missing
 Broken

Signature: _____

圖示說明
Illustration:



Optional
選擇使用



Open Hole
鑽孔



Cut Off
切除



Agglutinate
用膠黏合



No Agglutinate
不用黏合



Make 2 Sets
二組製作



Instant Glue
使用瞬間膠



Fill Hole
把孔填平



Be Careful
注意



Remove
將其磨去



Symmetrical part
對稱

Method For Applying Decals:

1. Clean Model Surface With Wet Cloth.
2. Cut Out Of Decal Sheet And Dip Them In Warm Water For 15 Seconds.
3. Place it on proper position on model.
4. Slide off base paper leaving decals On Model With Wet Finger Tip.
5. Move Decals To Exact Position, Push Out Excess Water Under Decal With Soft Cotton Cloth.
6. When Decals Get Dry Then Complete.

水貼紙使用說明:

1. 將模型表面擦乾淨
2. 將貼紙剪下泡入溫水中浸泡約 15秒
3. 將泡濕之貼紙取出置於欲貼處旁
4. 用指尖輕推貼紙表面使其滑出底紙
5. 將貼紙調整至適當位置並輕擦拭水份
6. 待其自然乾燥後即完成

Color list: 塗料表

Color	Brand	GSI Creos			Humbrol	AV Vallejo	Lifecolor
		Hobby Color	Mr.Color	Mr.Color Spray			
Flat black	消光黑	H12	C33	S33	33	70950	LC02
Flat white	消光白	H11	C62	S62	34	70919	LC01
IDF Gray 1	以色列灰		C528		84	71141	UA901
Red	紅	H3	C3	S3	19	70926	LC56
Red brown	紅褐	H47/H406	C41	S41	160	71019	UA085
Sail color	帆布	H85	C45		28	72149	UA099
Silver	銀	H8	C8	S8	11	70997	LC74
Steel	黑鐵	H18	C28	S28	53	77712	LC76
Tire black	輪胎黑	H77	C137		85	70950	LC02
Wood brown	木棕	H37	C43		186	70876	UA85
Brass	黃銅		C219		54	70801	LC75

1

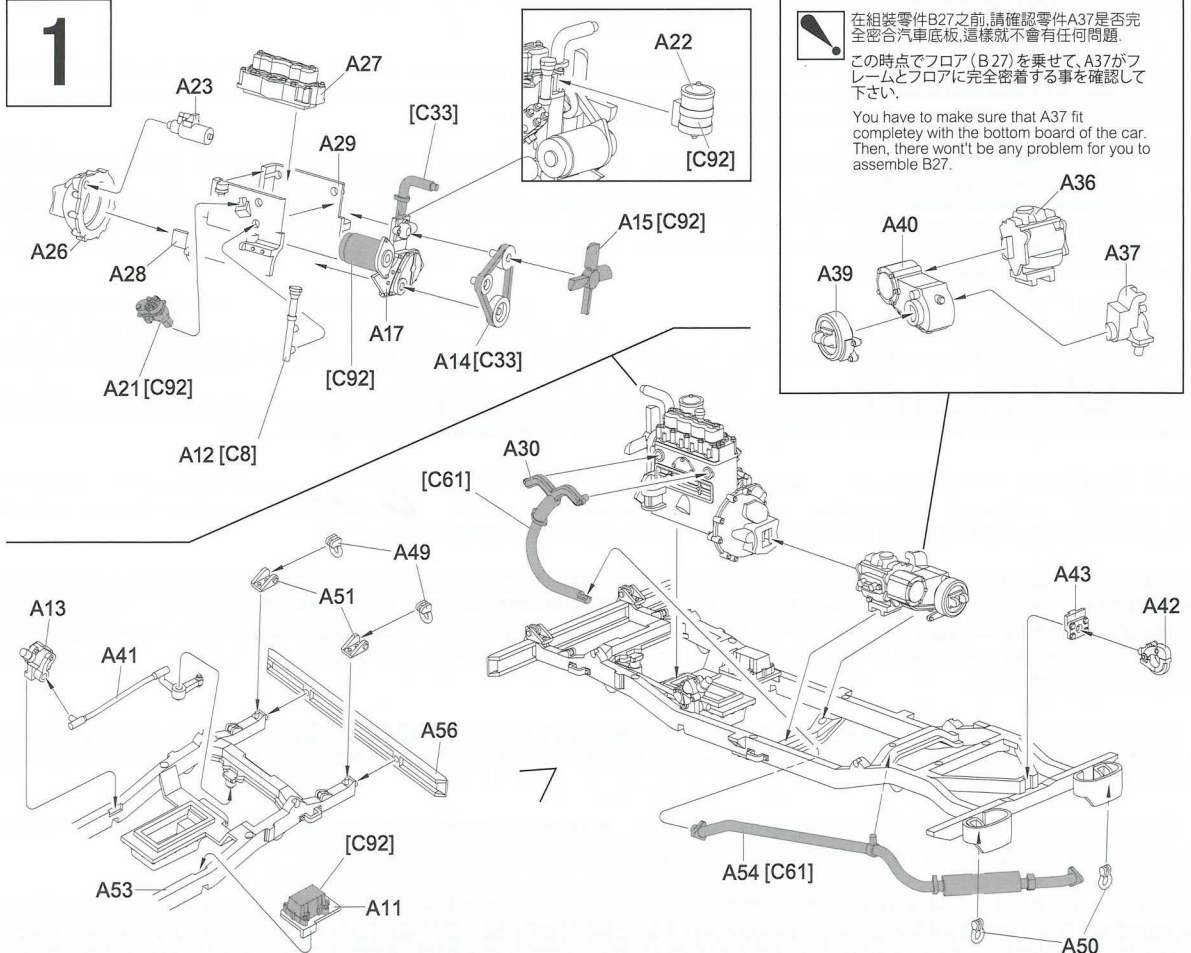

2

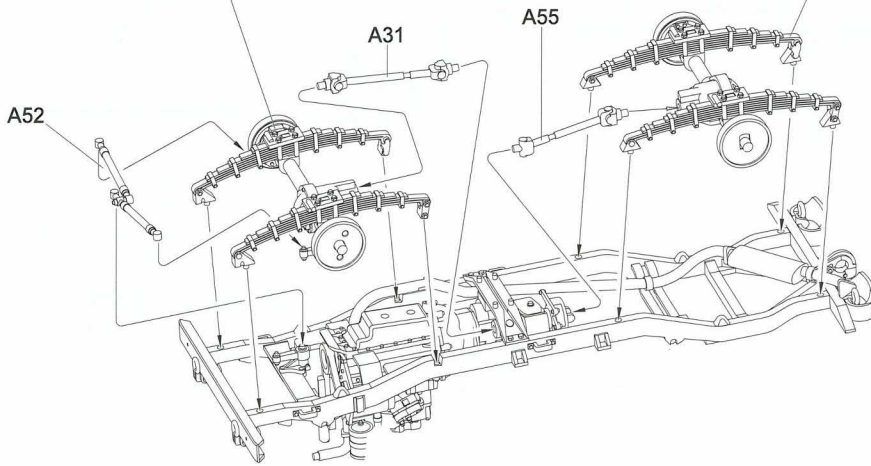
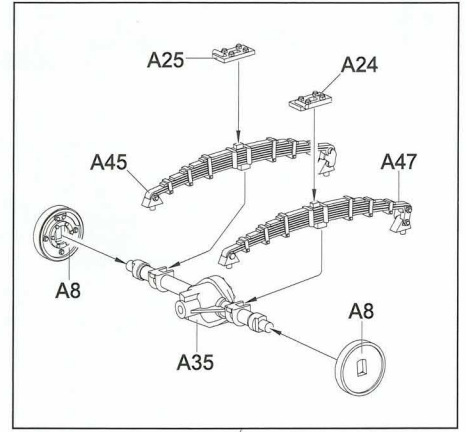
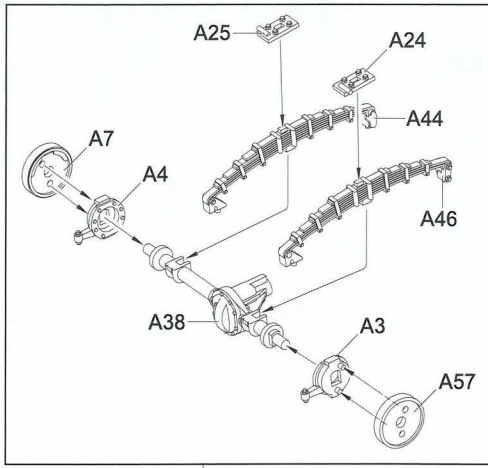

3

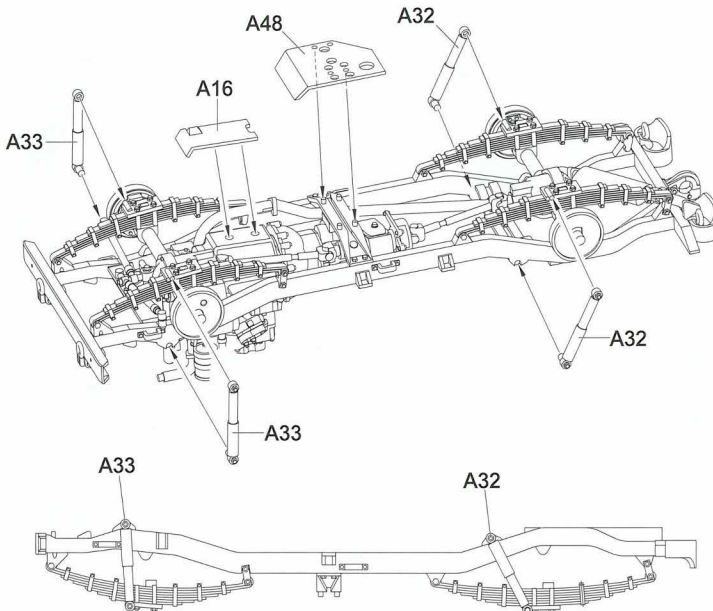

4

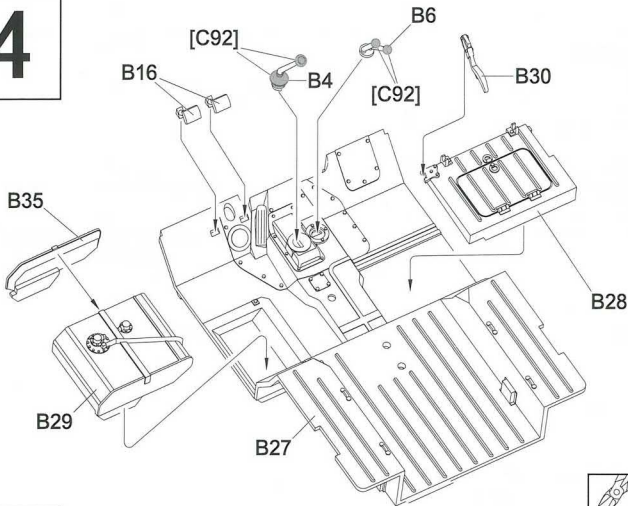

B24 及 B26 需製作
B24 & B26 feature need to be removed and fill them.

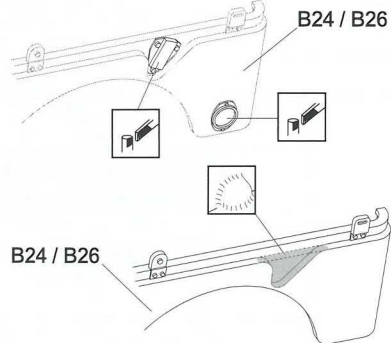

5



安裝 B12 前須將 E29 上色並貼上水貼。
Before installing B12, E29 need to be painted and applied decal.

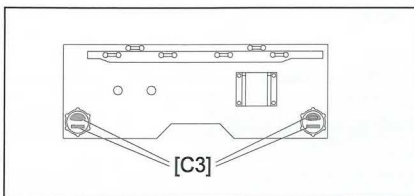
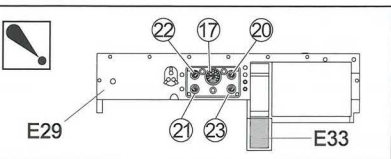
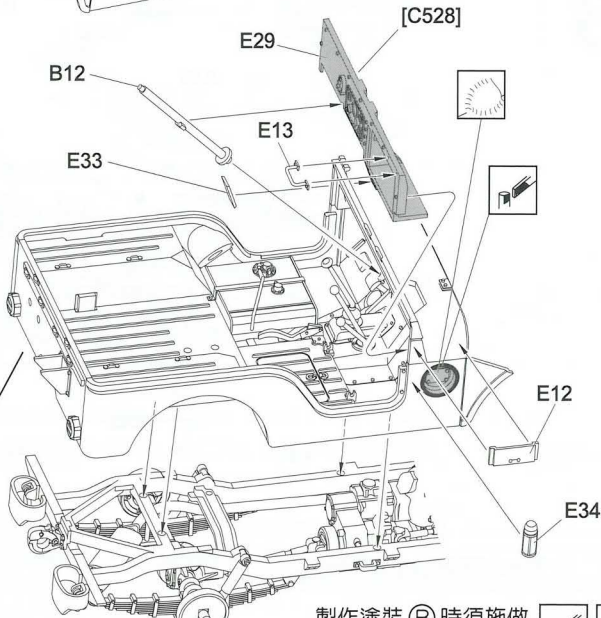
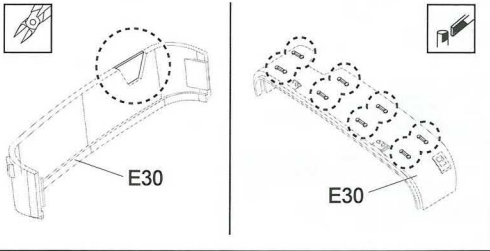
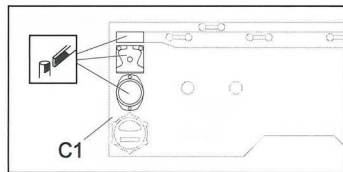
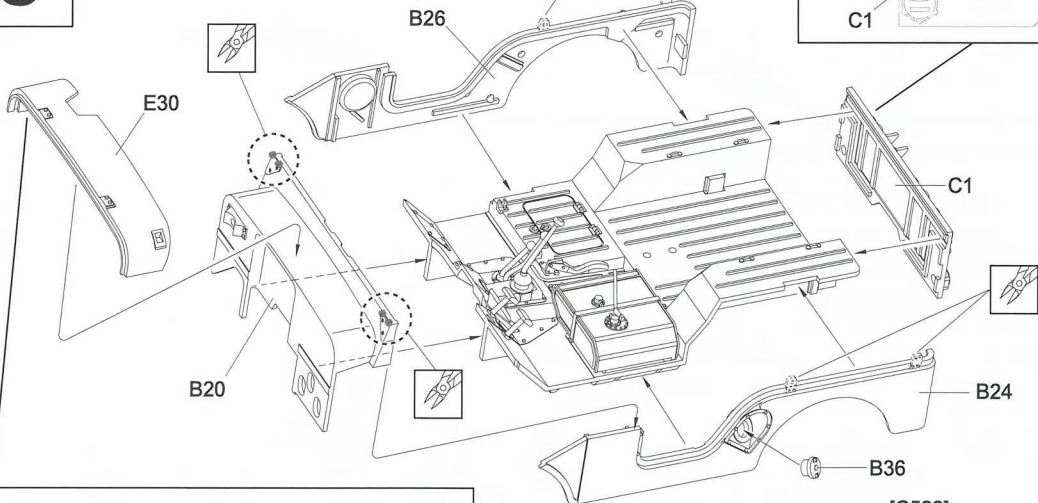

製作塗裝 時須施做。

Choice the painting of B, the hole need to be filled.cal.



6

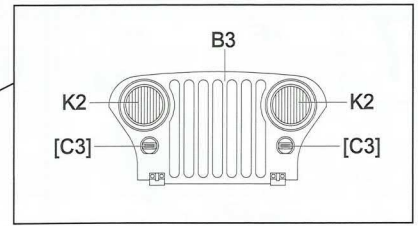
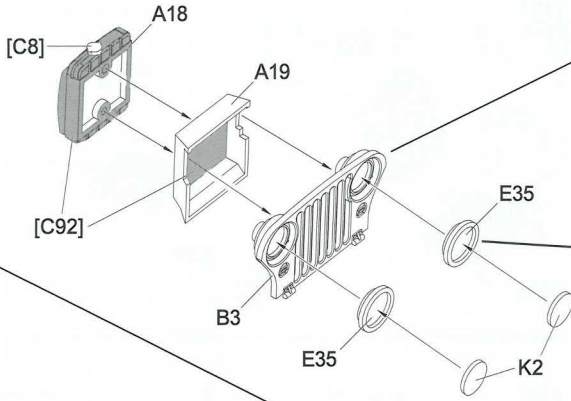

組裝CJ-5車型時才需組裝E35。
The E35 assembly only for building up CJ-5 series.

(A)

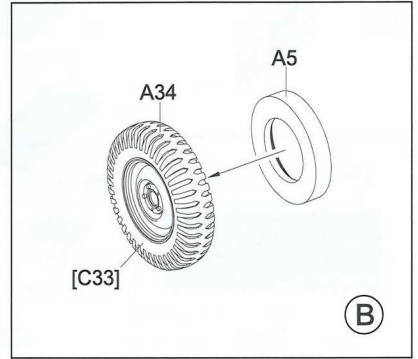
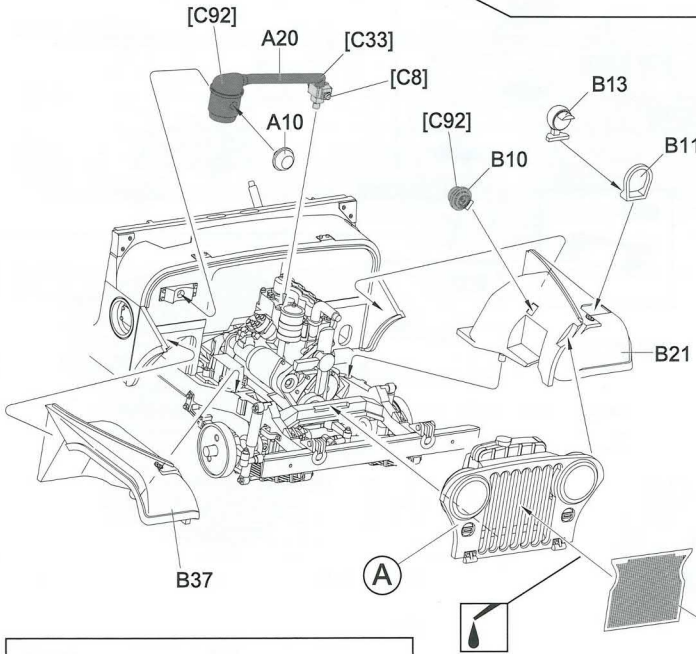

(B)

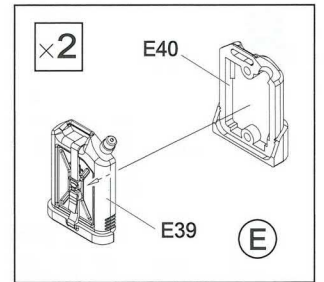

(E)

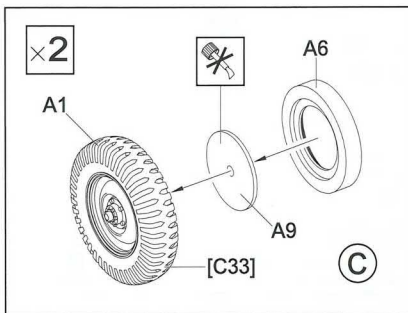

(C)

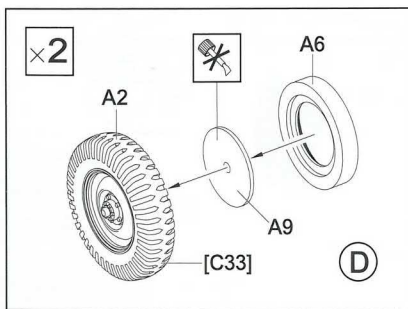

(D)

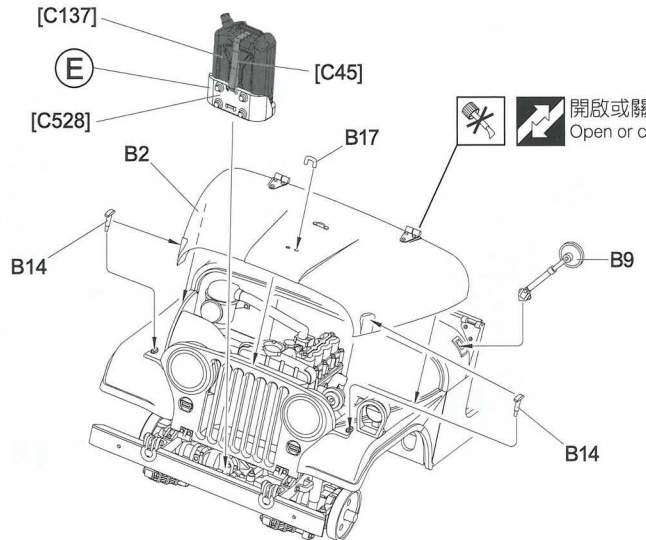

開啟或關閉。
Open or close.

7

F

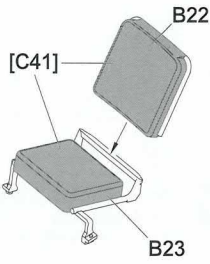

G

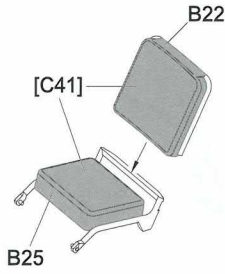

H

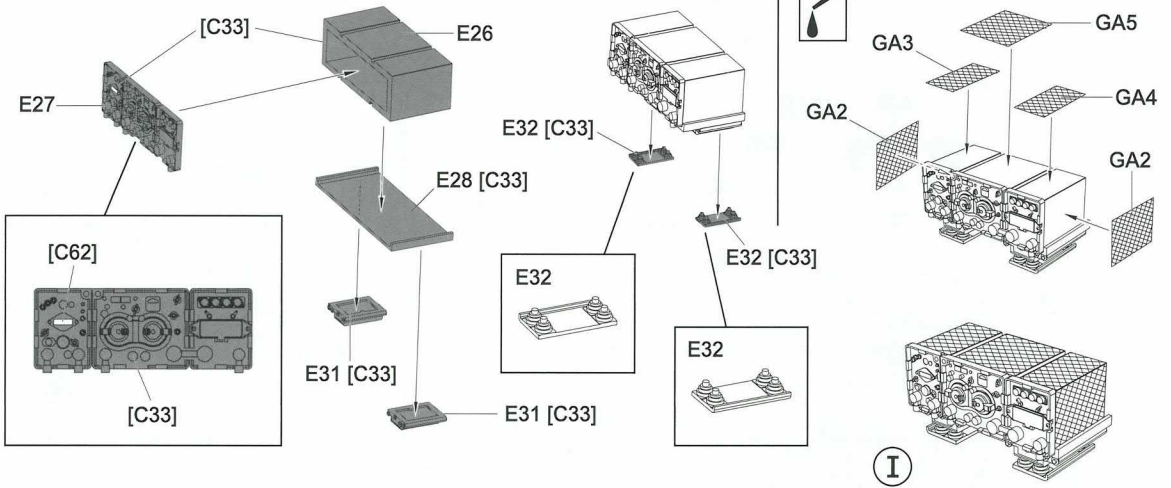
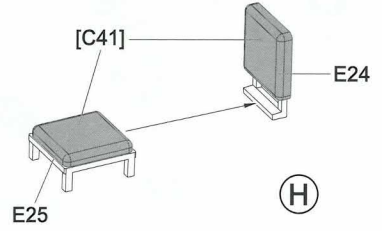

8

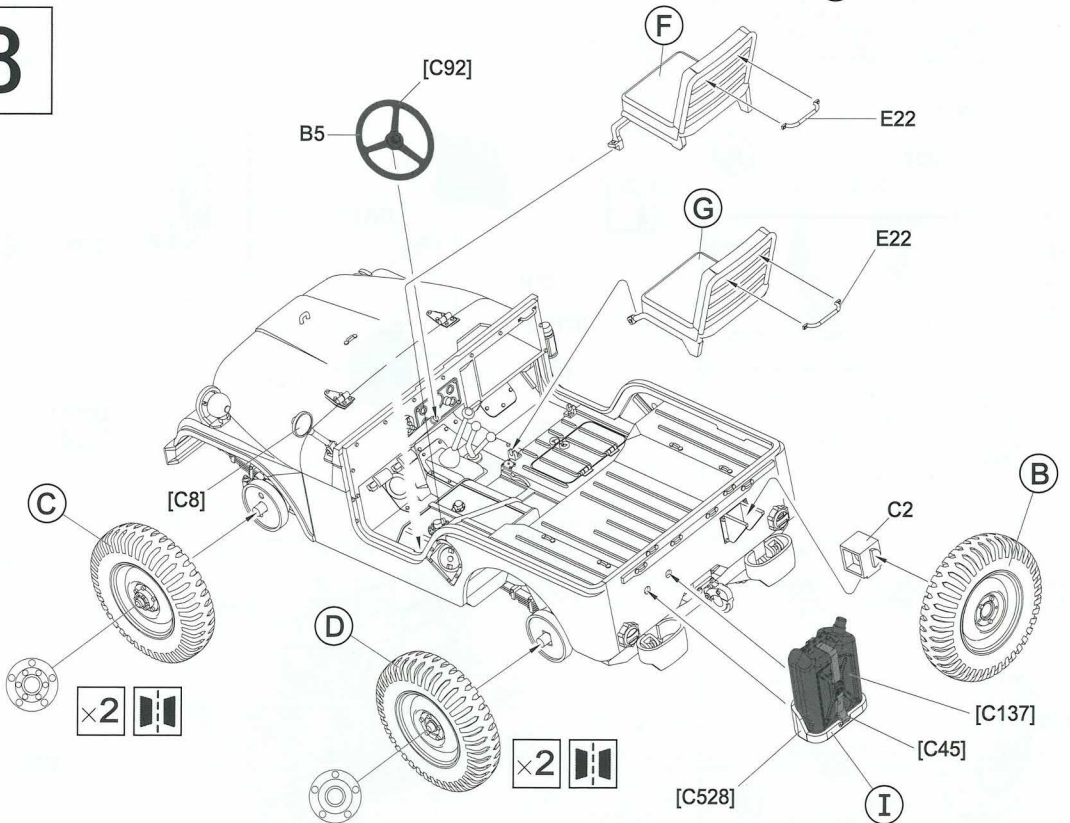

9

無線電配置.
The position of radio station set.

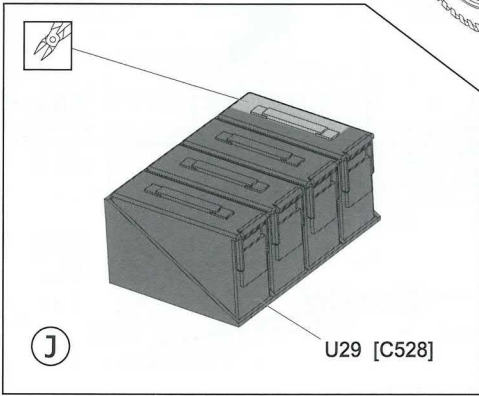
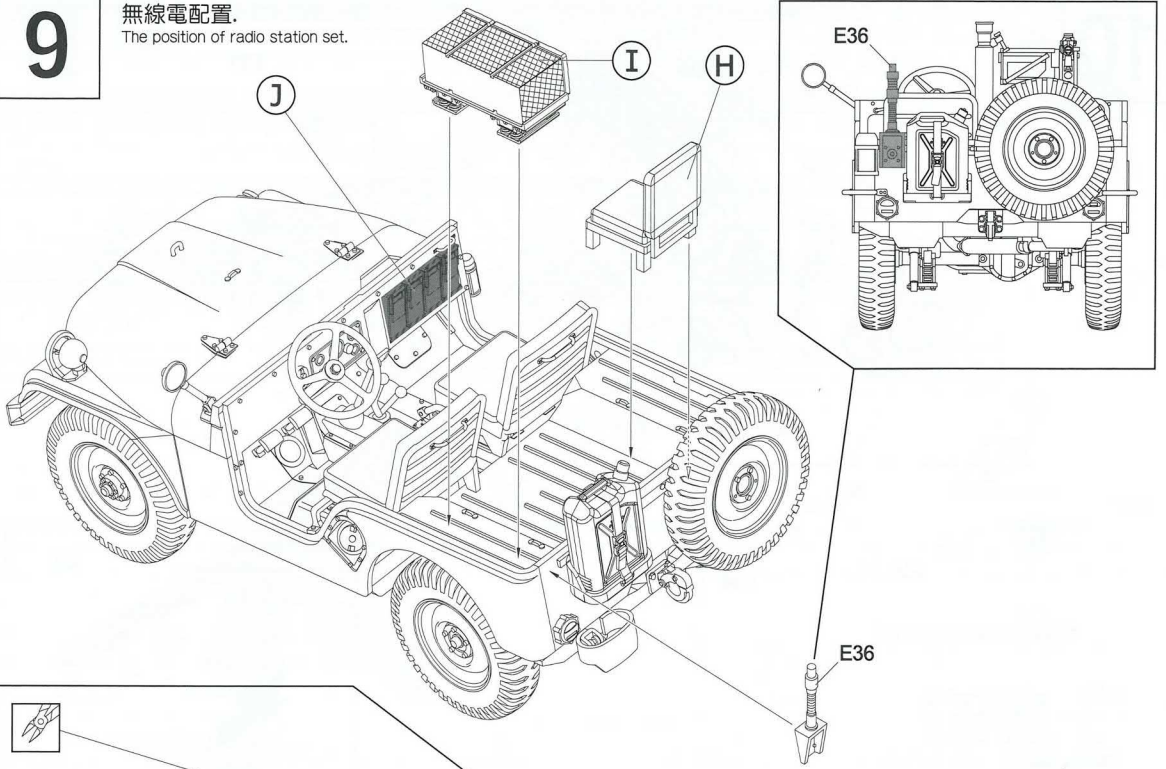

左置無線電.
Left side position.

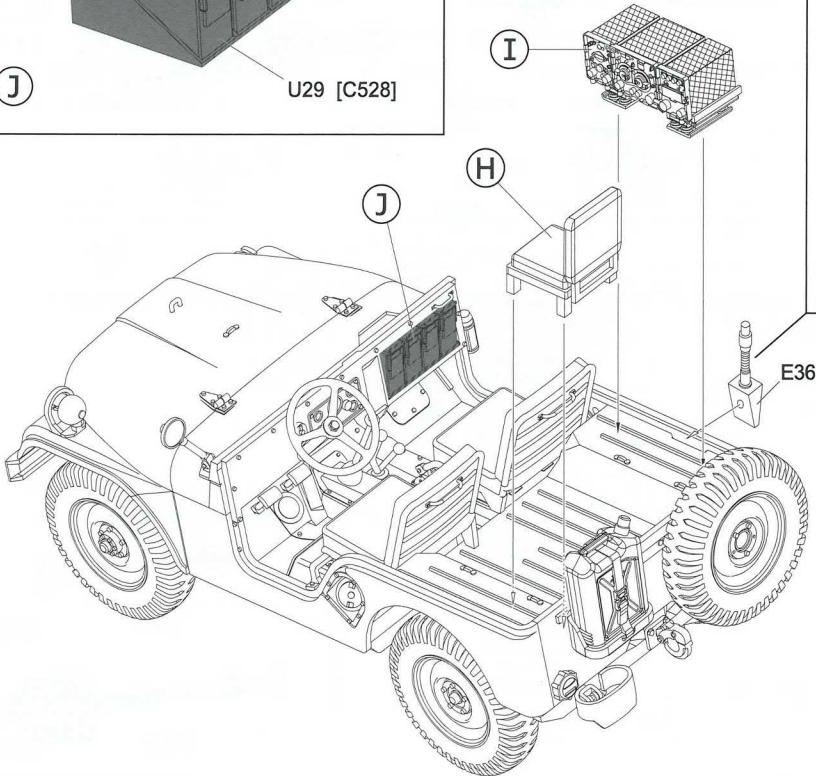

右置無線電.
Right side position.

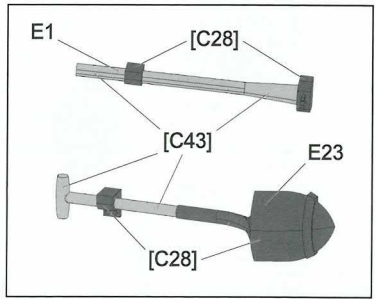
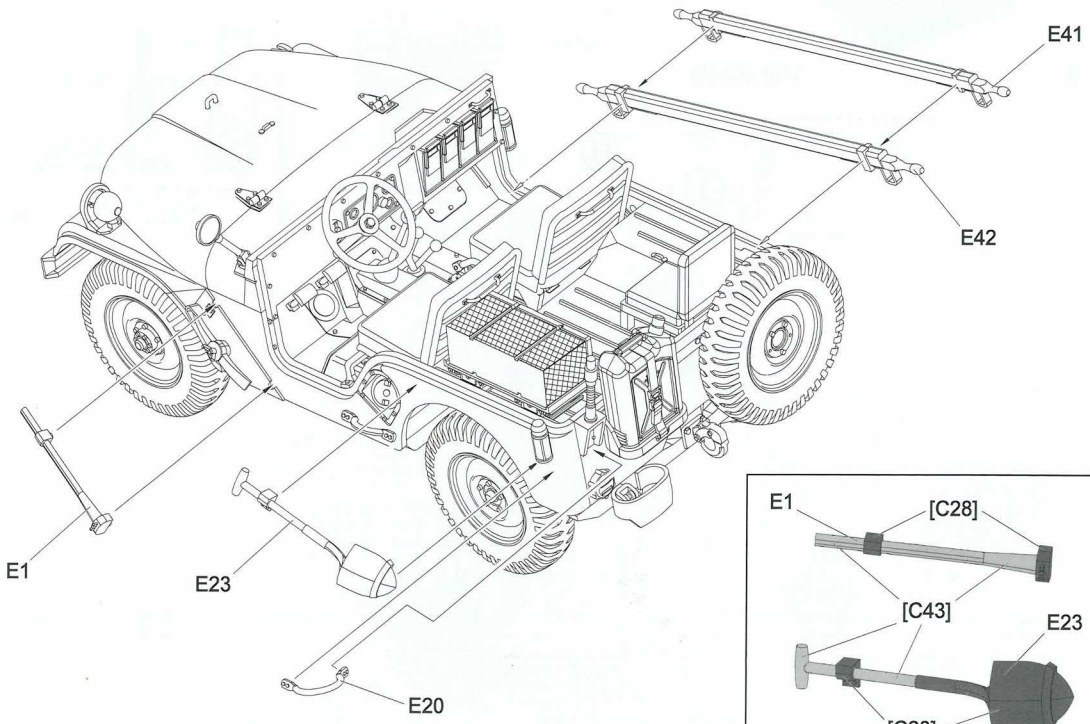
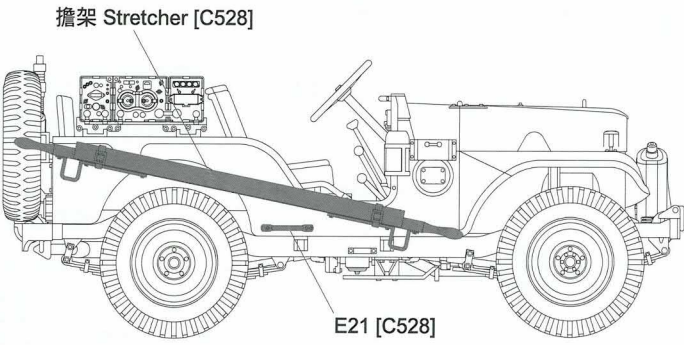
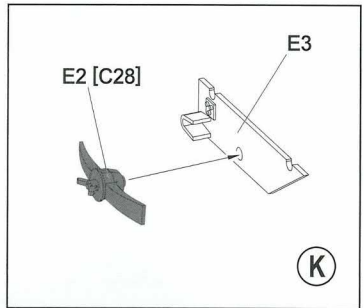
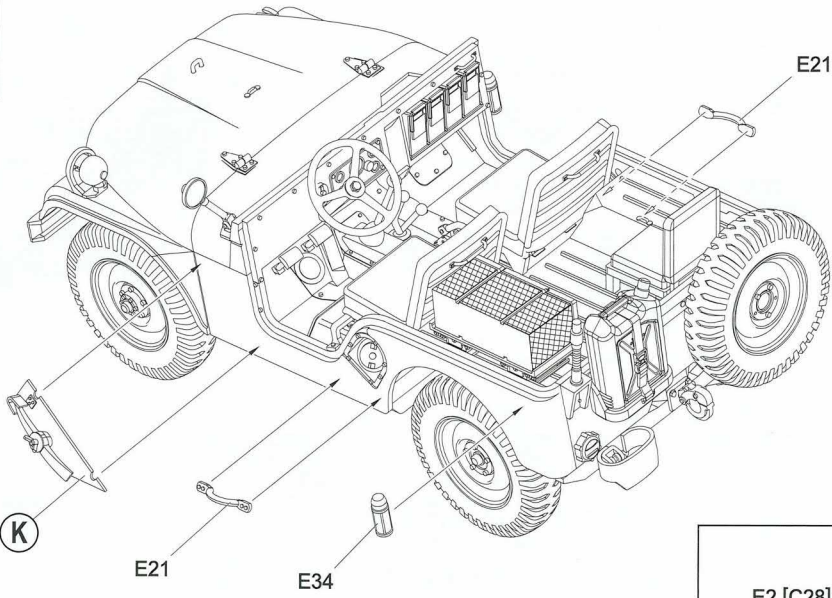

11



不安裝機槍時跳過此步驟。
Don't do this step, if you don't instal the .30 cal MG.

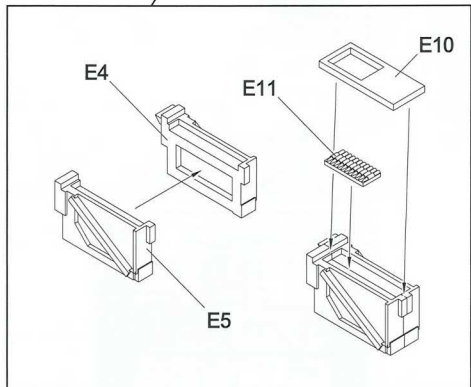
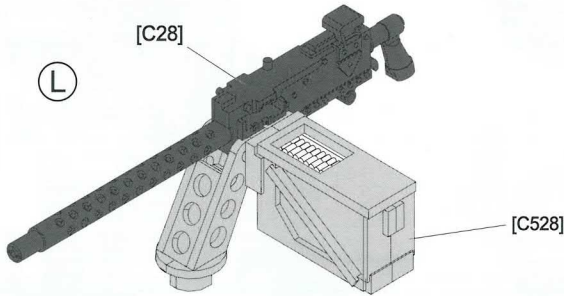
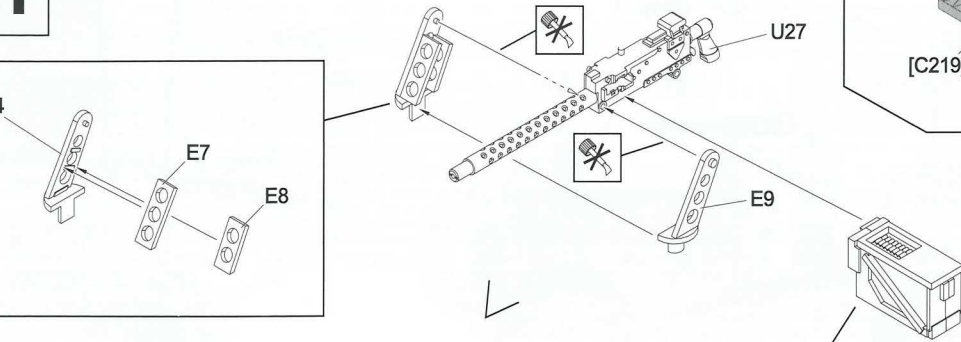
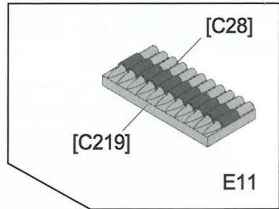
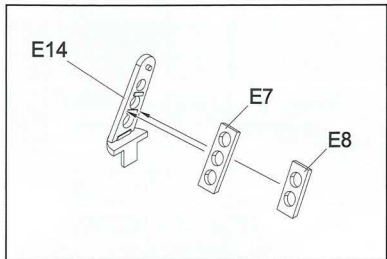

12

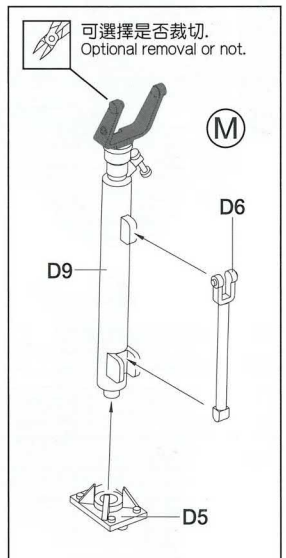
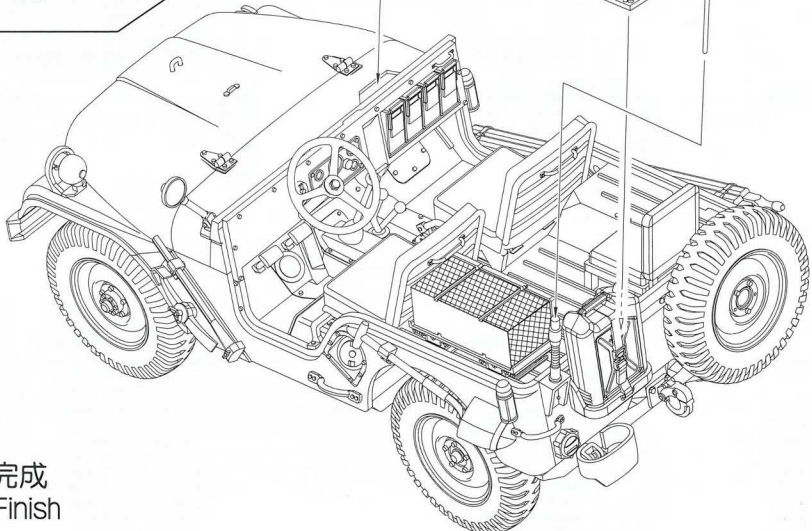
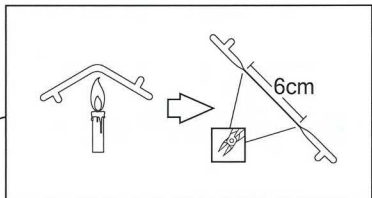
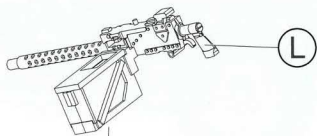
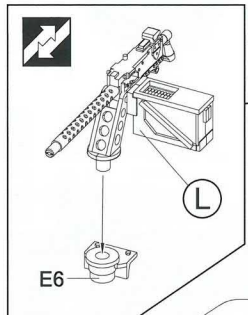

完成
Finish

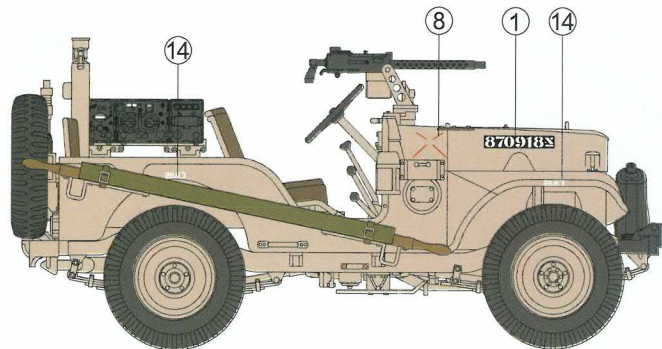
ABody Color:  Flat black  Flat white IDF Gray 1

24

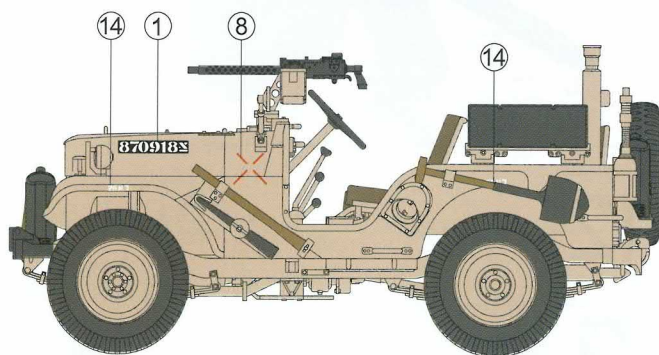
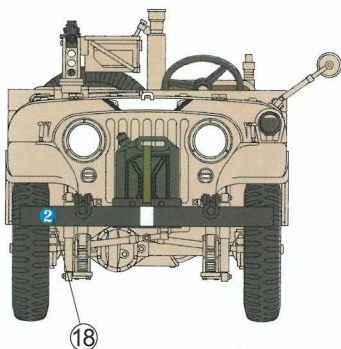
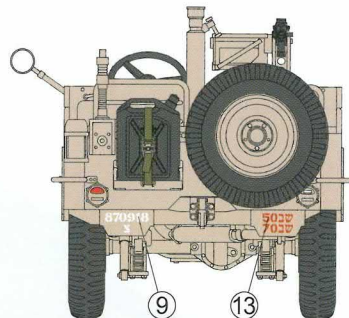
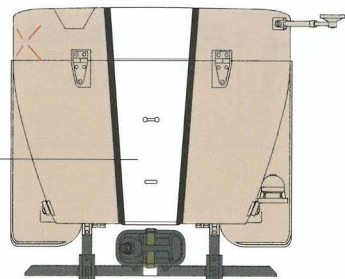
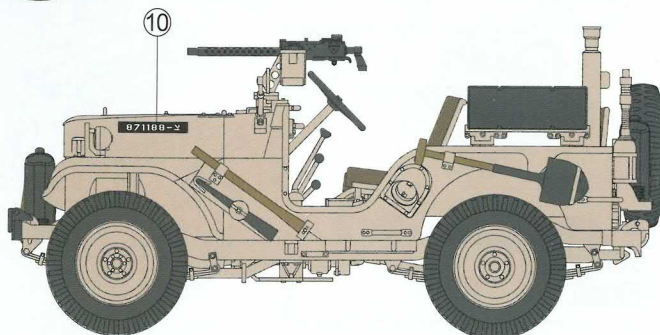
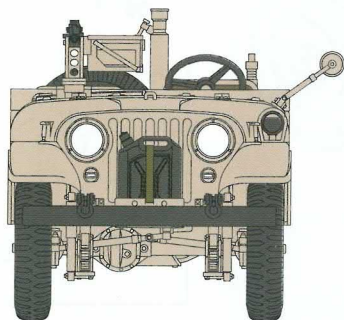
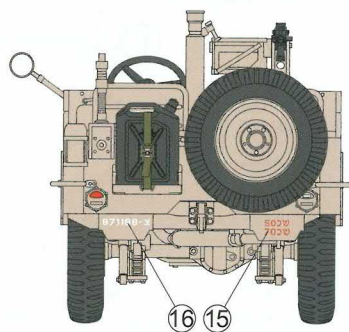
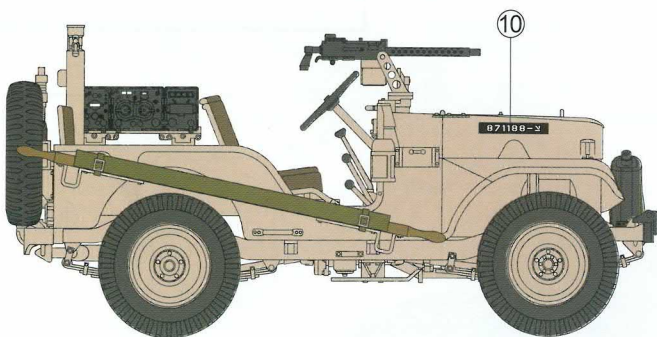
**B**Body Color:  IDF Gray 1  Flat black

C Body Color: IDF Gray 1 Flat black

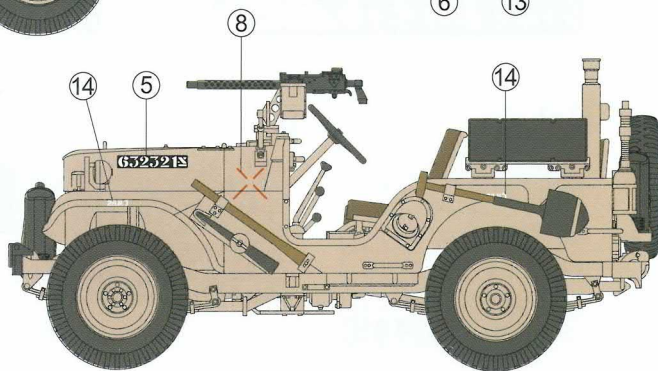
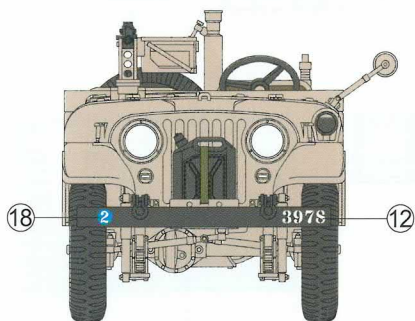
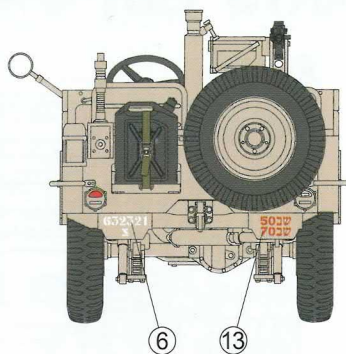
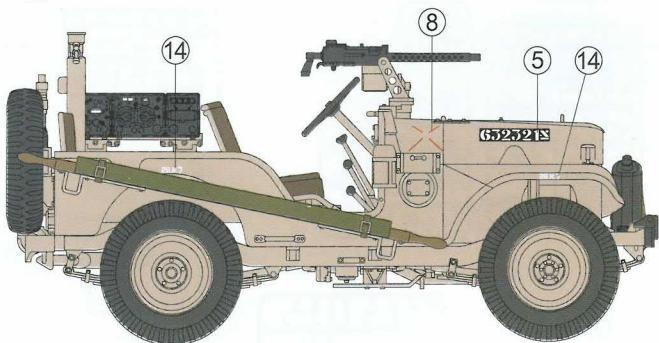

D Body Color: Flat black IDF Gray 1

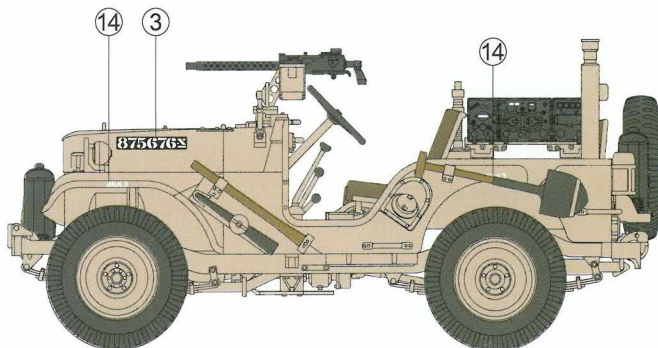
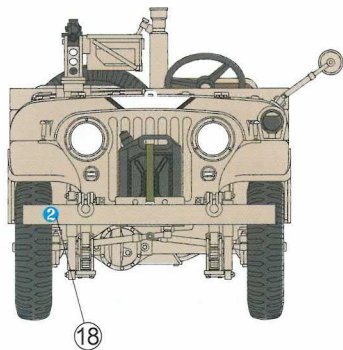
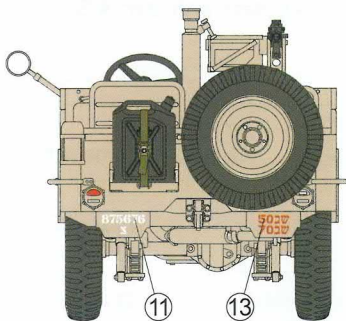
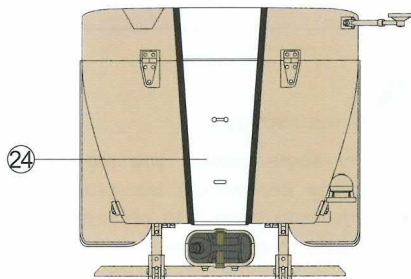
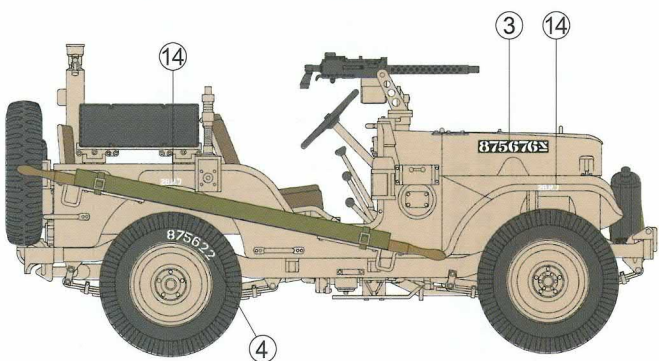

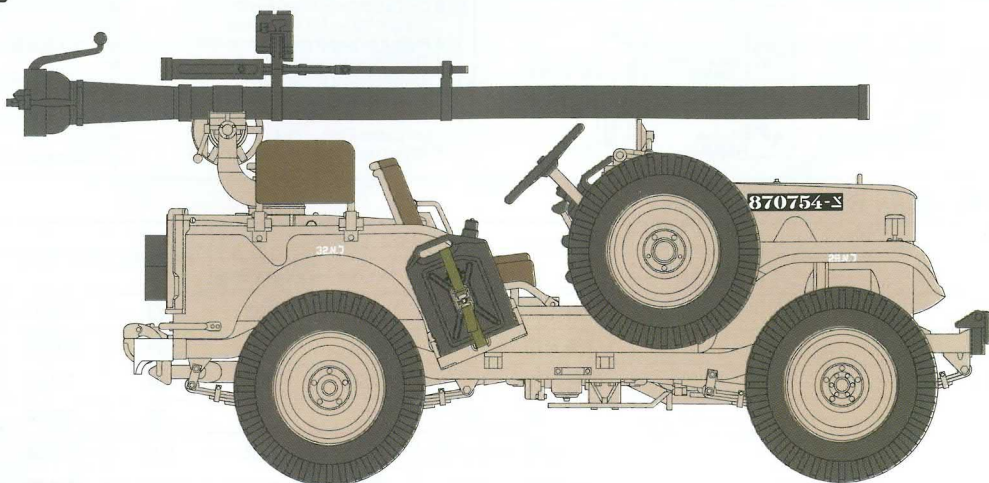

TOLAR

IDF 1/4 TON 4x4 RECOILLESS RIFLE VEHICLE M38A1/CJ-5

The Jeep or Willys MB, produced by Willys-Overland, was a light military utility vehicle used widely by the Allies during WWII. With an impressive production figure of well over 600,000 units, through Lend Lease, this nimble little four wheel drive vehicle appeared in all theaters of the war. In 1952, Willys-Overland produced a successor, the Willys MD, which incorporated numerous upgrades including a strengthened chassis, longer wheelbase, redesigned radiator, front grill, and hood to accommodate an engine with higher output. The Willys MD saw action in Korea and Vietnam.

In 1920, the League of Nations mandated British administration of Palestine and the Jeep was introduced into the area by the British. After the end of WWII, a large migration of Jews settled in Palestine. With the development of the Zionist movement, the newly formed Jewish settlement began procuring arms and vehicles and thus the Willys MB entered the inventory of the Israeli Defense Force (IDF).

In 1965, the IDF purchased a series of CJ-5 (civilian version of the M38A1) with a variety of armament installations as well as some M606A2 (export version of the M38A1). They were deployed to the field soon after modifications were made according to the specifications listed by the IDF. These modifications consisted of a reconnaissance version of the CJ-5, SIYUR, which had a 7.62mm machine gun installed on a swivel base in front of the right front seat. Radio equipment was also installed in the SIYUR. An anti-armor version of the CJ-5, the TOLAR; to that of the American M38A1c, was equipped with an M40A1, 106mm recoilless rifle. Both variants participated in the 1967 Six Day War. The TOLAR was later replaced by the TOW anti-tank missile equipped CJ-5 ORLEV after the end of 1973 Yom Kippur War.

Text edited by John D. Miller, Ph.D,

Owner Model Paint Solutions.com

ウィリスオーバーランド社によって開発されたジープやウィリスMBは、第二次世界大戦中に連合国によって広く使用された軽量の小型軍用車両です。60万台を超える驚異的な生産数とレンドリース法により、この小型四輪駆動車は全ての戦場で目にする事が出来ました。ウィリスオーバーランド社は、1952年に後継モデルのM38A1(ウィリスMD)を発表しました。これには、シャーシの強化やホイールベースの延長、高出力エンジンに対応するためのラジエーターやフロントグリル、フードの再設計など、多くのアップグレードが施されました。このウィリスMDは後に韓国やベトナムの戦場で使用されました。

1920年、国際連盟はパレスチナの統治をイギリスに委託し、それによってパレスチナへウィリスジープが導入されました。第二次世界大戦後、多くの無国籍ユダヤ人がパレスチナへ移住しました。シオニズム運動(パレスチナにユダヤ人の国家を築くことを目指した運動。)の発展に伴い新たに形成されたユダヤ人の入植地では、世界中から武器や車両を購入することが出来るようになり、ウィリスMBもイスラエル国防軍に導入されました。

1965年、イスラエル国防軍は様々な種類の武器が取り付けられたCJ-5(M38A1の民間車版型)と、M606A2(M38A1の軍用輸出型)を購入しました。イスラエル国防軍に規定された仕様に従い改修が行われた後、戦場に投入されました。中でも、偵察任務を務めたCJ-5 SIYURIは、副操縦席の前に7.62mm口径機関銃を設置、無線通信装備の設置といった改造が行われました。対装甲担当のCJ-5 TOLARは、アメリカ軍のM38A1Cと同様の構成で、後部にM40A1 106mm口径無反動砲が装備されました。両車は1967年の第三次中東戦争に参加し、TOLARは1973年の第四次中東戦争終結後、牽引対戦車ミサイルを搭載したCJ-5 OREVIにその役目を引き継ぐこととなりました。

威利吉普(Willys MB)が盟軍在第二次世界大戦期間大量採用の軍用軽型車輛、透過租借法案及六十幾萬輛の龐大產量、使得各個戰場都能見到這種四輪驅動車的身影。1952年威利公司推出了後繼車款M38A1(Willys MD)、強化了底盤並加長軸距、採用比MB更大功率的發動機、為此重新設計水箱護罩與引擎蓋、日後投入了韓國與越南的戰場中使用。

1920年國際聯盟委託英國管轄巴勒斯坦，英國人也將威利吉普引進此處。二戰結束後大量無国籍猶太人移入巴勒斯坦，隨著猶太復國運動的推進，海外的猶太人也設法從世界各地採購武器和車輛，Willys MB自此也進入了以色列部隊之中。

1965年以色列國防軍訂購了一系列搭載各式武裝的CJ-5(M38A1的民間版)、與M606A2(M38A1的軍用外銷版)、經過了適應以色列需求的修改後運用於戰場。其中擔任偵察任務的CJ-5 Siyur在副駕駛前面安裝了一挺7.62mm口径機槍，並裝備了無線電通信設備。擔任反裝甲任務的CJ-5 Tolar與美國M38A1c的配置相同，車後方搭載了一門M40A1 106mm無後座力砲。這兩款車輛均參與了1967年的六日戰爭，後者在1973年的贖罪日戰爭後，陸續為配備拖式反戰車飛彈的CJ-5 Orev所取代。

PARTS LIST 零件表

(B) x1 AF35S17

(C) x1 AF35S19

(A) x1 AF35S17

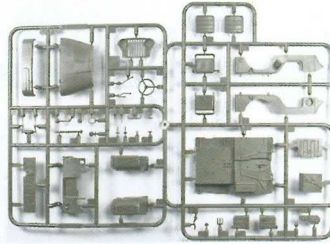
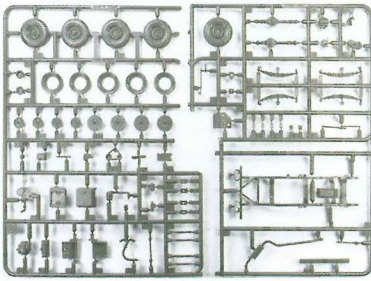

(G) x1 AF35S94



(K) x1 AF35S17

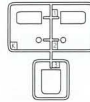

(E) x1 AF35S94

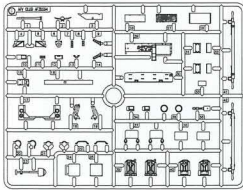

(D) x1 AF35S19

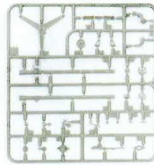

(J) x1 AF35S96



Instructions:

If for some reason, you are not fully satisfied or have questions concerning our product; Please use the form provide, and send it to our nearest representative or mail it directly to our office.

We will deal with that A.S.A.P.



AF 35S96 Parts Replacement Form

- | | |
|-------------------------------------|--------------------------------------|
| <input type="checkbox"/> AF 35S17-A | <input type="checkbox"/> AF 35S94-E |
| <input type="checkbox"/> AF 35S17-B | <input type="checkbox"/> AF 35S96-J |
| <input type="checkbox"/> AF 35S19-C | <input type="checkbox"/> AF 35S96-GA |
| <input type="checkbox"/> AF 35S19-D | |
| <input type="checkbox"/> AF 35S17-K | |

Reason for replacement: Missing
 Broken

Signature: _____

限臺灣地區使用 For Taiwanese use only!



AF 35S96 零件補充申請表

申請人
姓名
地址
電話

- | | |
|-------------------------------------|----------|
| <input type="checkbox"/> AF 35S17-A | NT\$ 160 |
| <input type="checkbox"/> AF 35S17-B | NT\$ 140 |
| <input type="checkbox"/> AF 35S19-C | NT\$ 100 |
| <input type="checkbox"/> AF 35S19-D | NT\$ 100 |
| <input type="checkbox"/> AF 35S17-K | NT\$ 50 |
| <input type="checkbox"/> AF 35S94-E | NT\$ 260 |
| <input type="checkbox"/> AF 35S96-J | NT\$ 160 |
| <input type="checkbox"/> AF 35S94-G | NT\$ 160 |

+郵寄費 _____ NT\$ 80

(請填)總計NT\$ _____

零件補充原因:(請於 打)

原包裝即 遺失或 毀損,

製作途中 遺失或 毀損,

其他原因 _____

總代理 戰鷹企業有限公司收本公司將儘速為您處理。
請將本表與該部品相同金額之郵政匯票一同寄至。

圖示說明
Illustration:



Optional
選擇使用



Open Hole
鑽孔



Cut Off
切除



Agglutinate
用膠黏合



No Agglutinate
不用黏合



Make 2 Sets
二組製作



Instant Glue
使用瞬間膠



Fill Hole
把孔填平



Be Careful
注意



Remove
將其磨去



Symmetrical part
對稱

Method For Applying Decals:

1. Clean Model Surface With Wet Cloth.
2. Cut Out Of Decal Sheet And Dip Them In Warm Water For 15 Seconds.
3. Place it on proper position on model.
4. Slide off base paper leaving decals On Model With Wet Finger Tip.
5. Move Decals To Exact Position, Push Out Excess Water Under Decal With Soft Cotton Cloth.
6. When Decals Get Dry Then Complete.

水貼紙使用說明:

- 1.將模型表面擦乾淨
- 2.將貼紙剪下泡入溫水中浸泡約15秒
- 3.將泡濕之貼紙取出置於欲貼處旁
- 4.用指尖輕推貼紙表面使其滑出底紙
- 5.將貼紙調整至適當位置並輕擦拭水份
- 6.待其自然乾燥後即完成

Color list: 塗料表

Color	Brand	GSI Creos			Humbrol	AV Vallejo	Lifecolor
		Hobby Color	Mr.Color	Mr.Color Spray			
Flat black	消光黑	H12	C33	S33	33	70950	LC02
Flat white	消光白	H11	C62	S62	34	70919	LC01
IDF Gray 1	以色列灰		C528		84	71141	UA901
Red	紅	H3	C3	S3	19	70926	LC56
Red brown	紅褐	H47/H406	C41	S41	160	71019	UA085
Sail color	帆布	H85	C45		28	72149	UA099
Silver	銀	H8	C8	S8	11	70997	LC74
Steel	黑鐵	H18	C28	S28	53	77712	LC76
Tire black	輪胎黑	H77	C137		85	70950	LC02
Wood brown	木棕	H37	C43		186	70876	UA85
Brass	黃銅		C219		54	70801	LC75

1

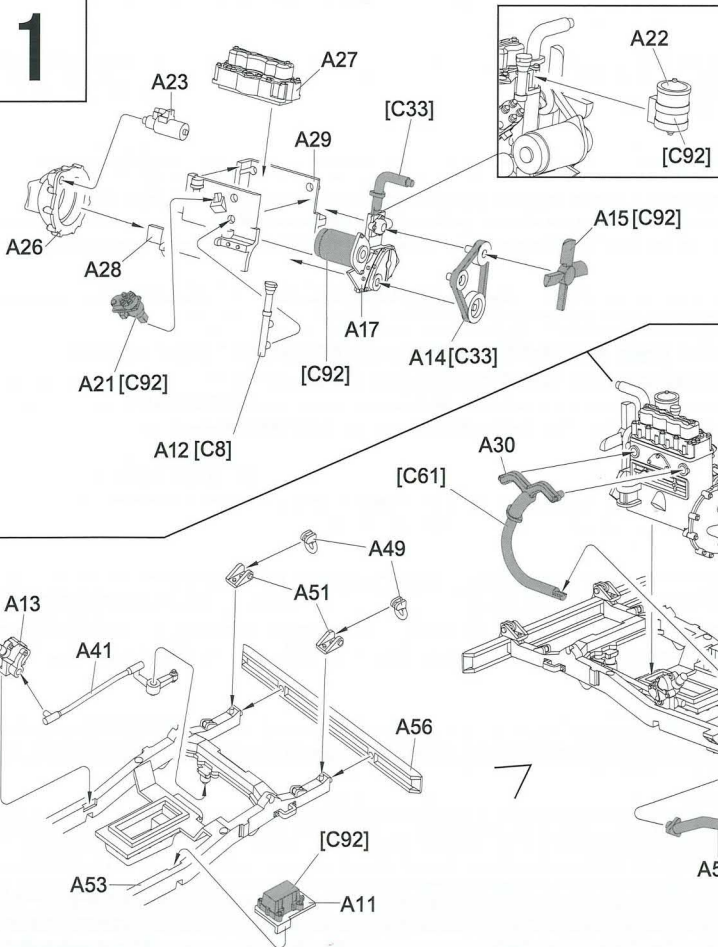

在組裝零件B27之前,請確認零件A37是否完全密合汽車底板,這樣就不會有任何問題。

この時点でフロア (B27) を乗せて、A37がフレームとフロアに完全密着する事を確認して下さい。

You have to make sure that A37 fit completely with the bottom board of the car. Then, there won't be any problem for you to assemble B27.

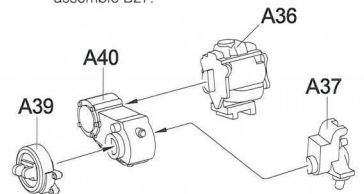

7

2

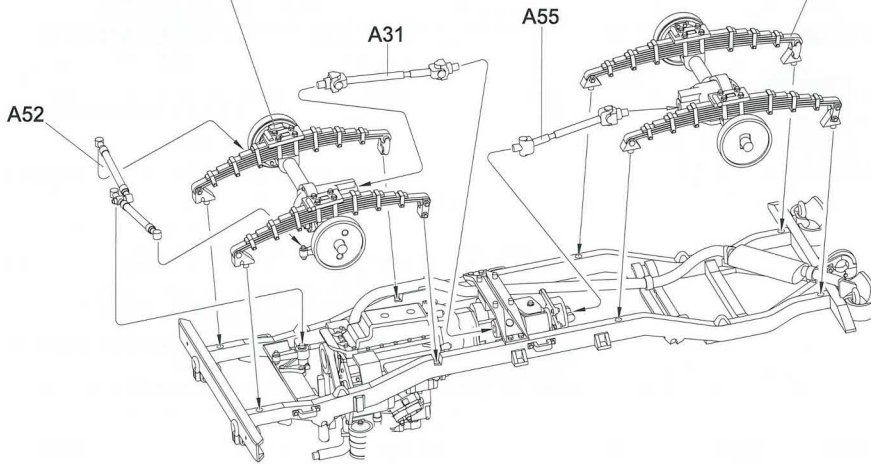
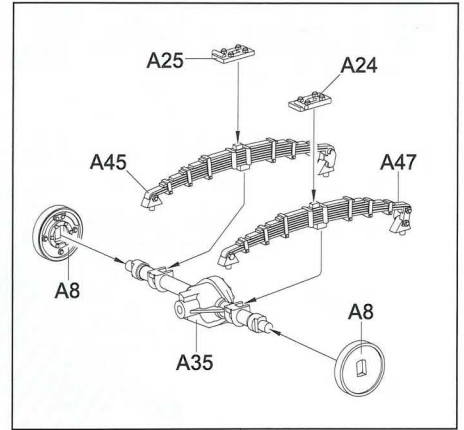
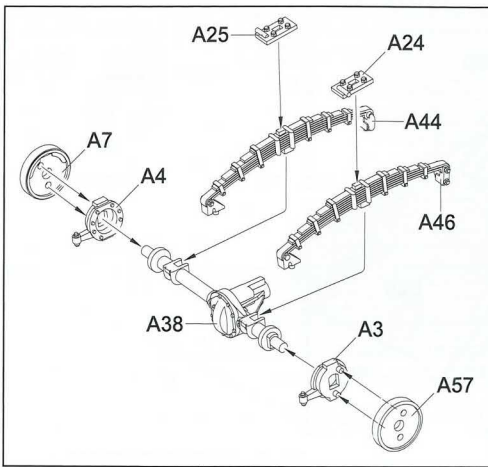

3

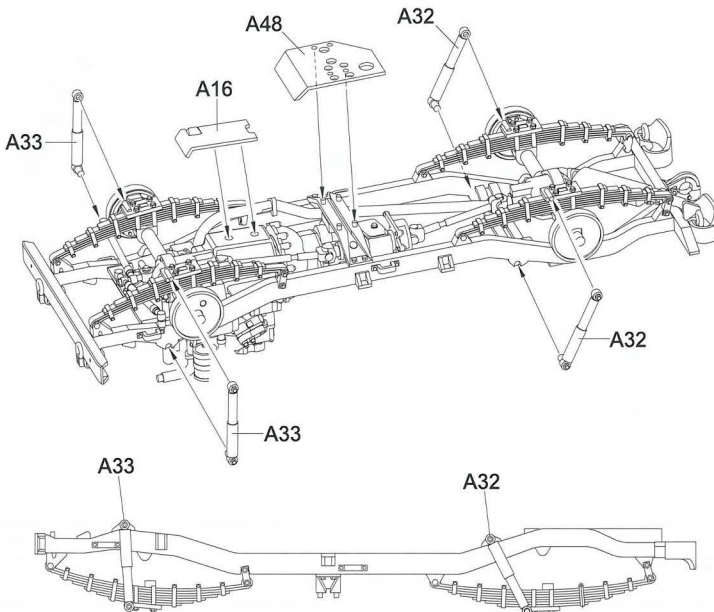

4

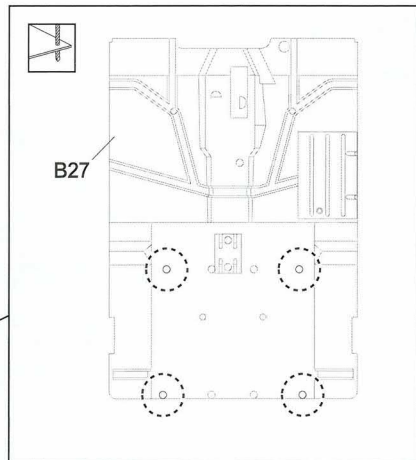
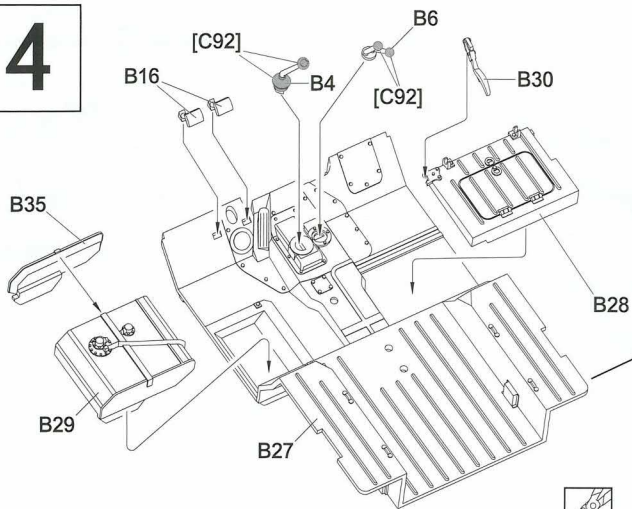

5

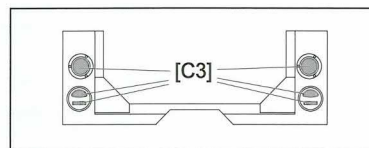
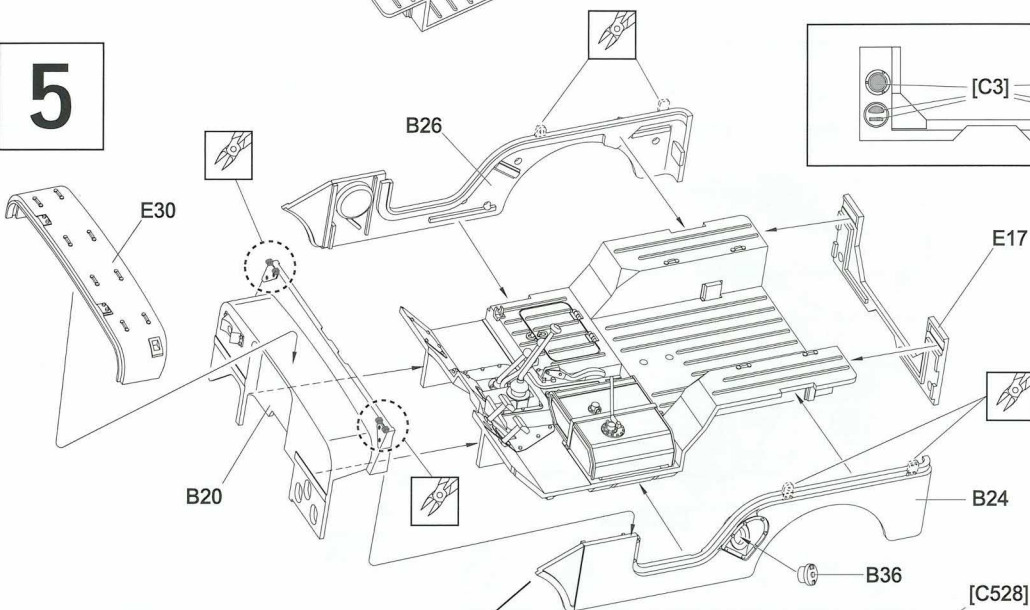

B24 及 B26 需製作。

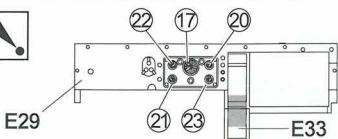
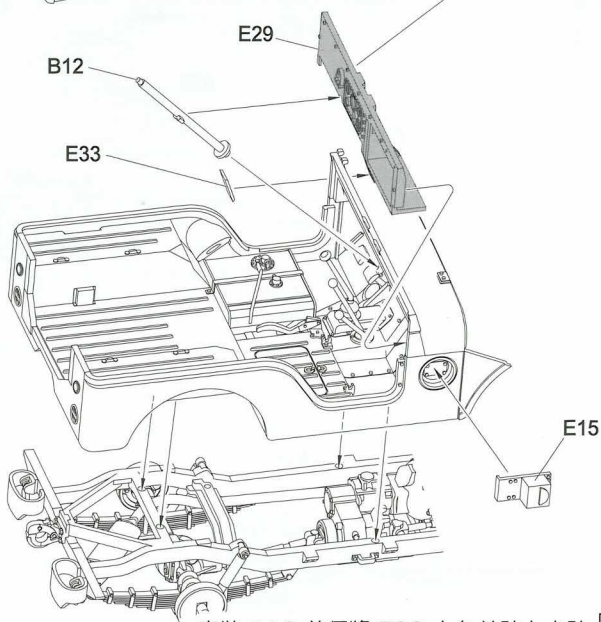
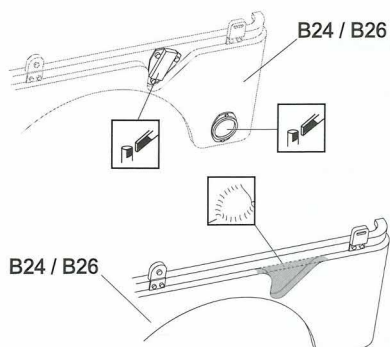

安裝 B12 前須將 E29 上色並貼上水貼。
Before installing B12, E29 need to be painted and applied decal.



6

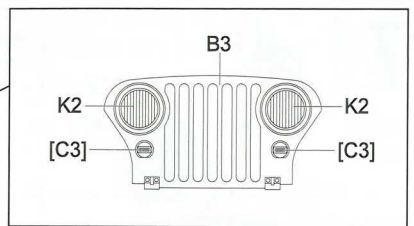
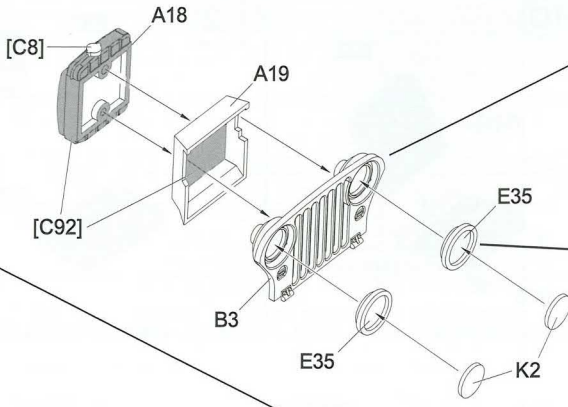

組裝CJ-5車型時才需組裝E35。
The E35 assembly only for building up CJ-5 series.

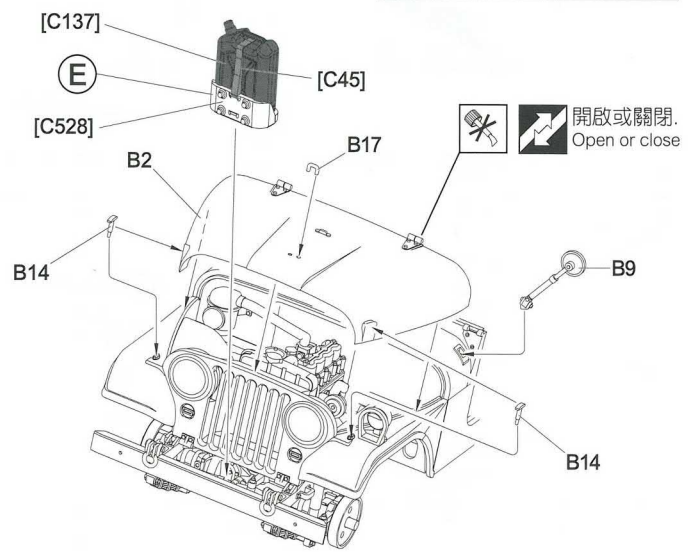
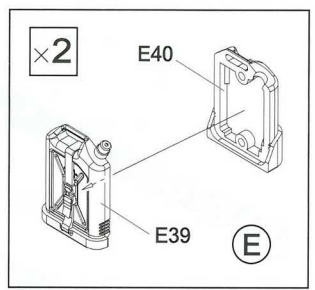
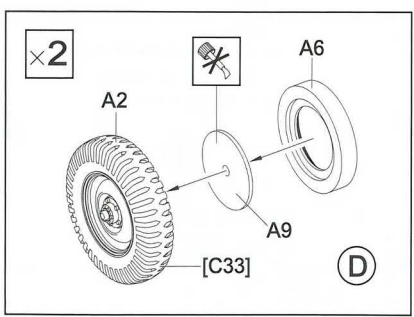
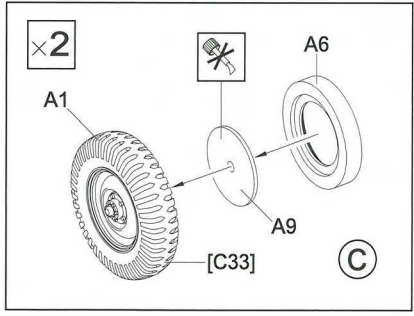
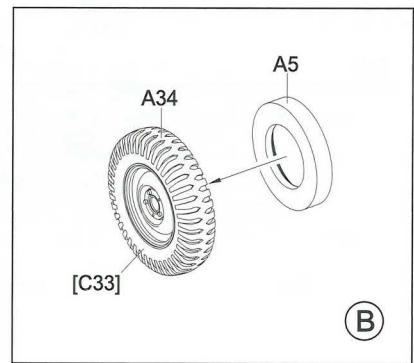
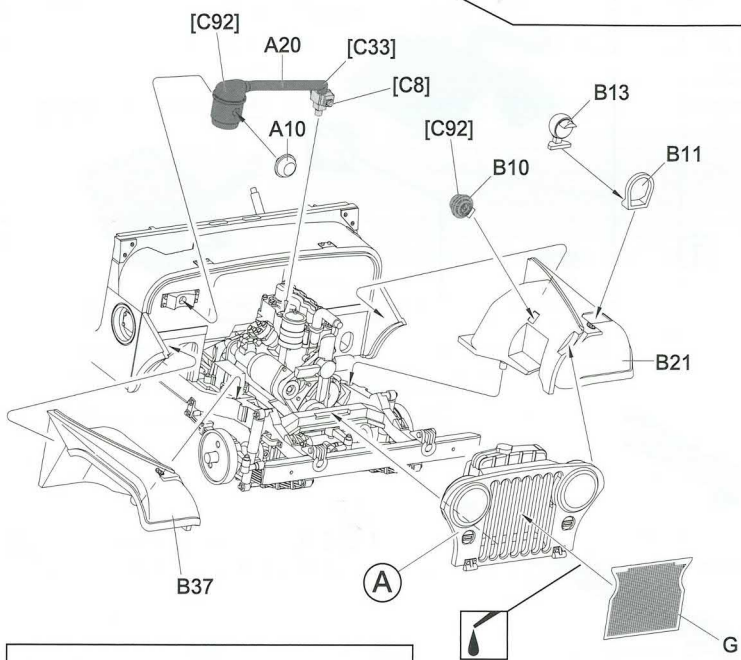

7

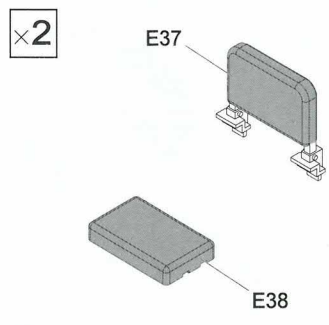
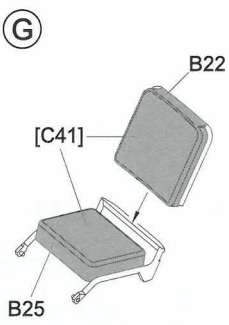
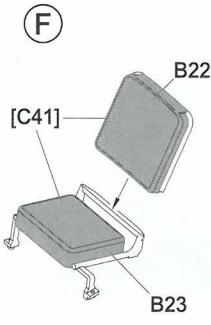

8

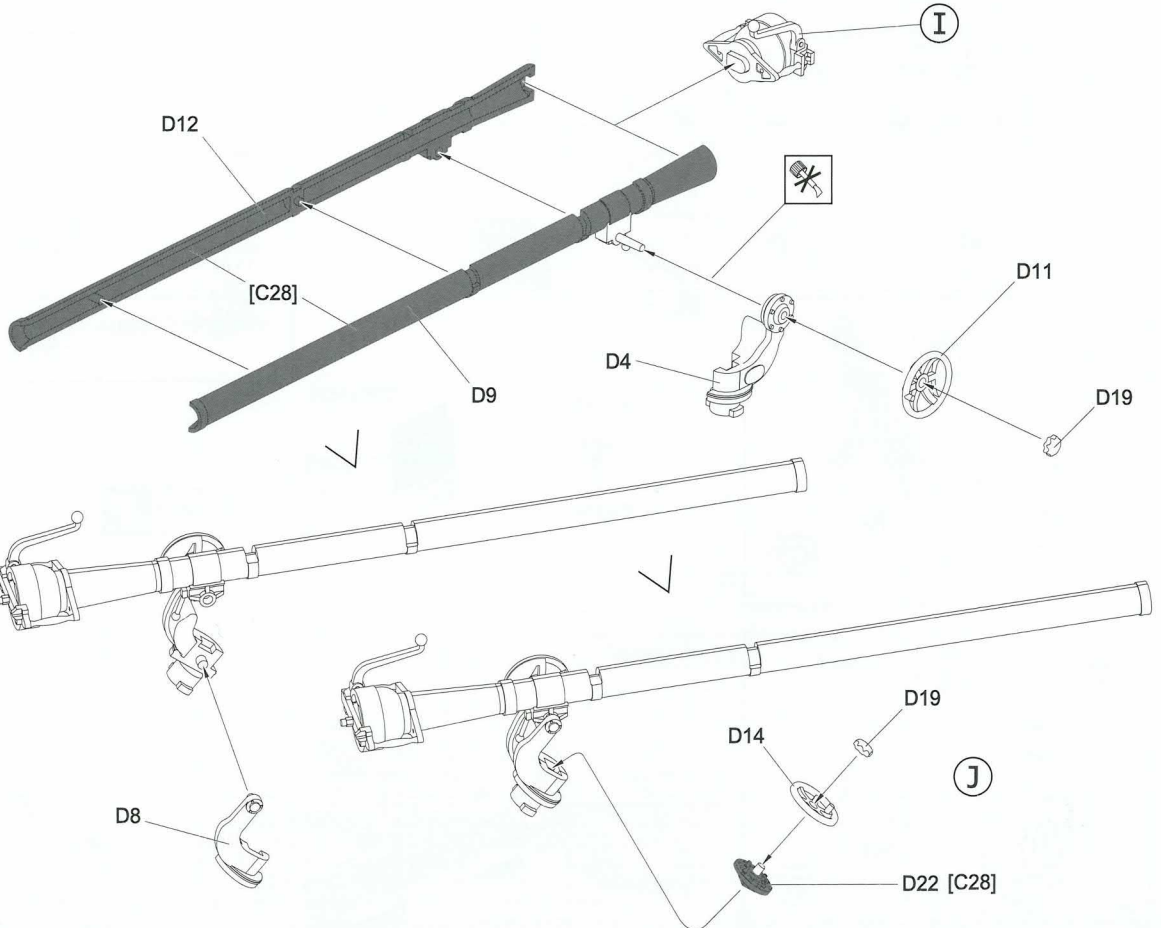
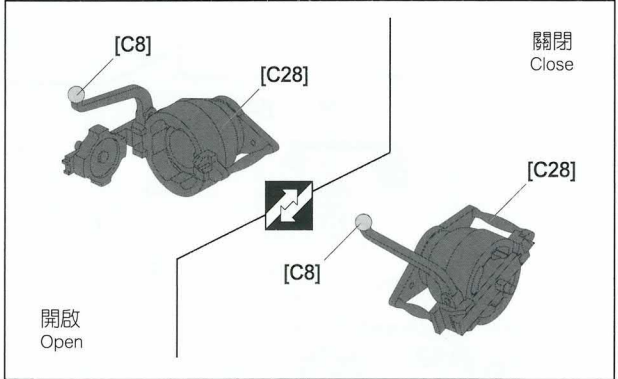
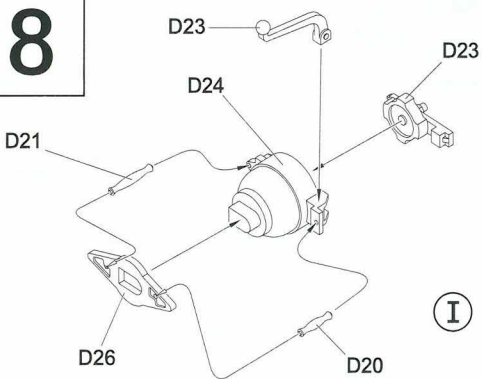

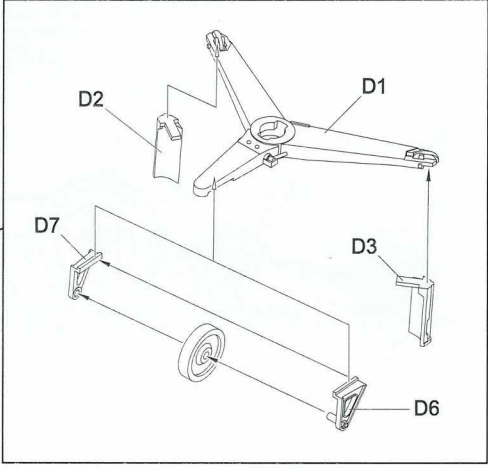
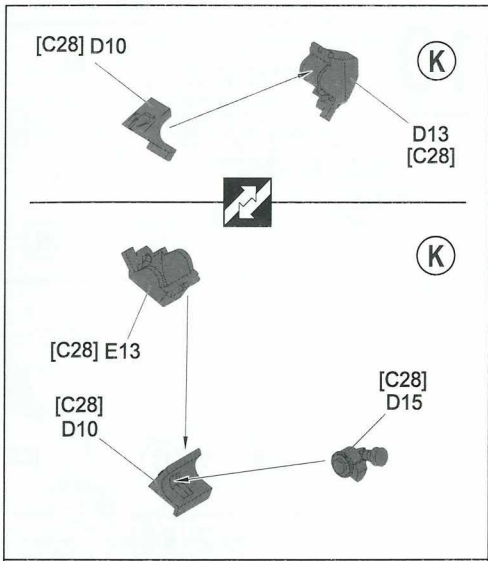
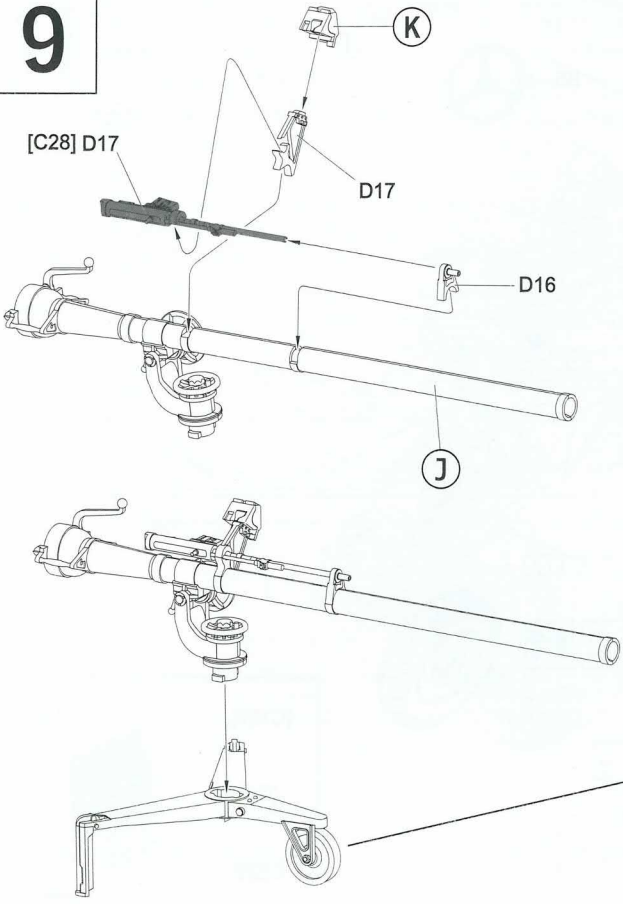

9

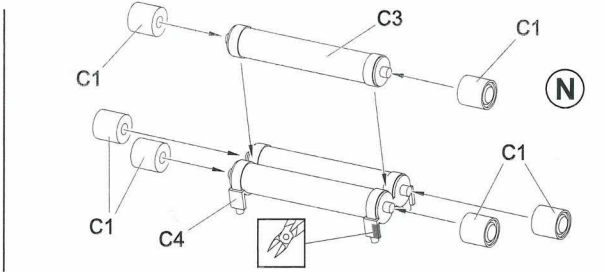
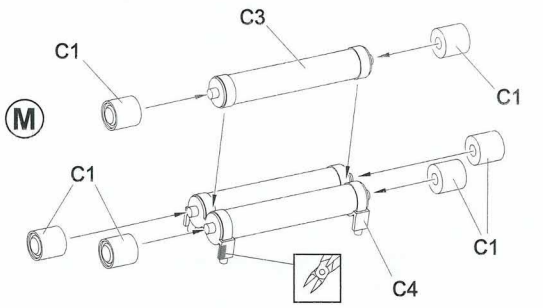
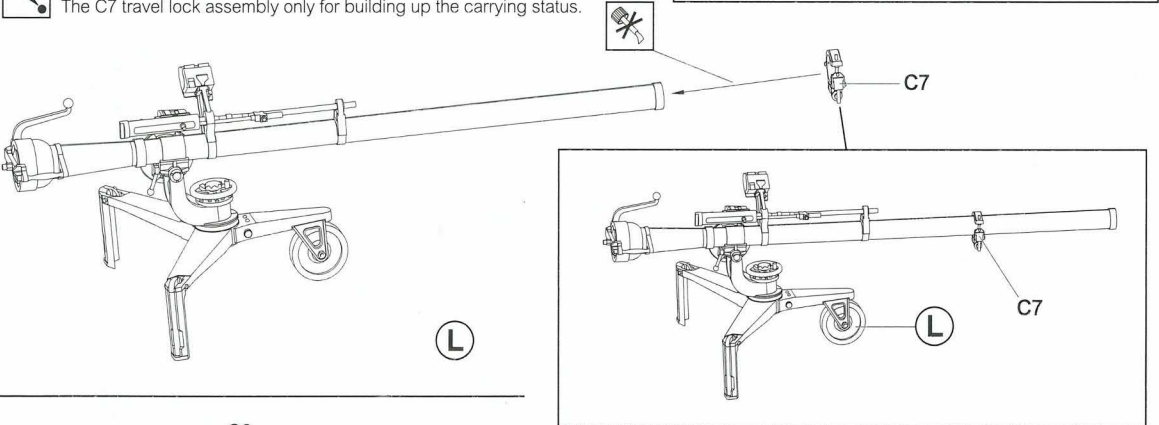

 製作運輸狀態時需在此步驟安裝C7板件。
The C7 travel lock assembly only for building up the carrying status.

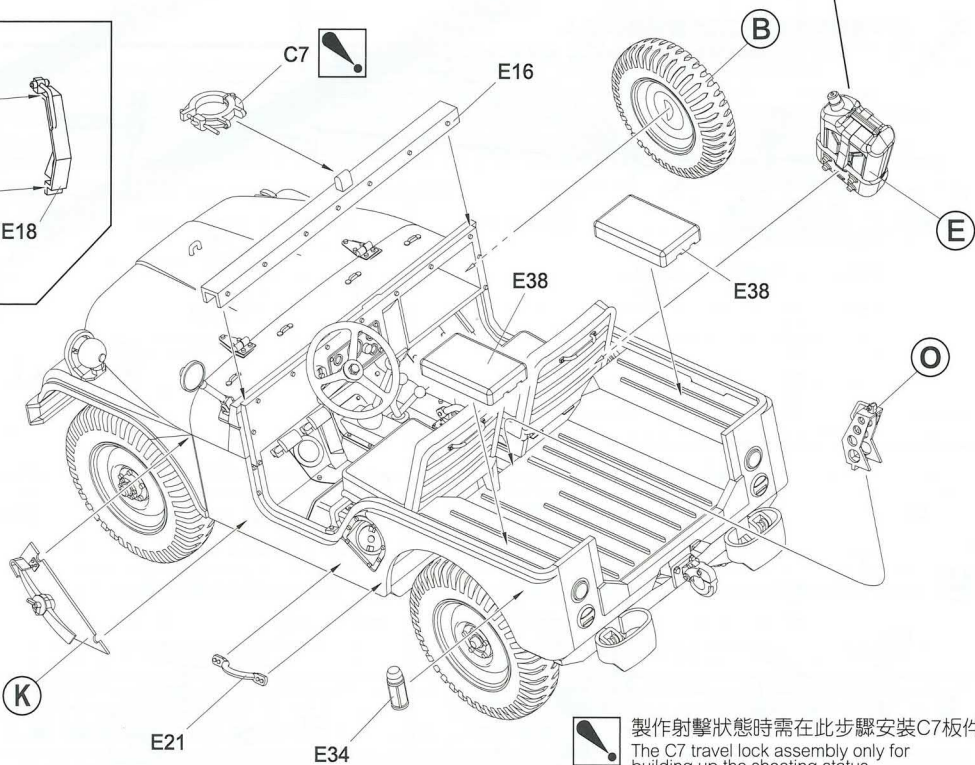
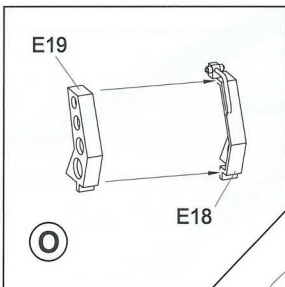
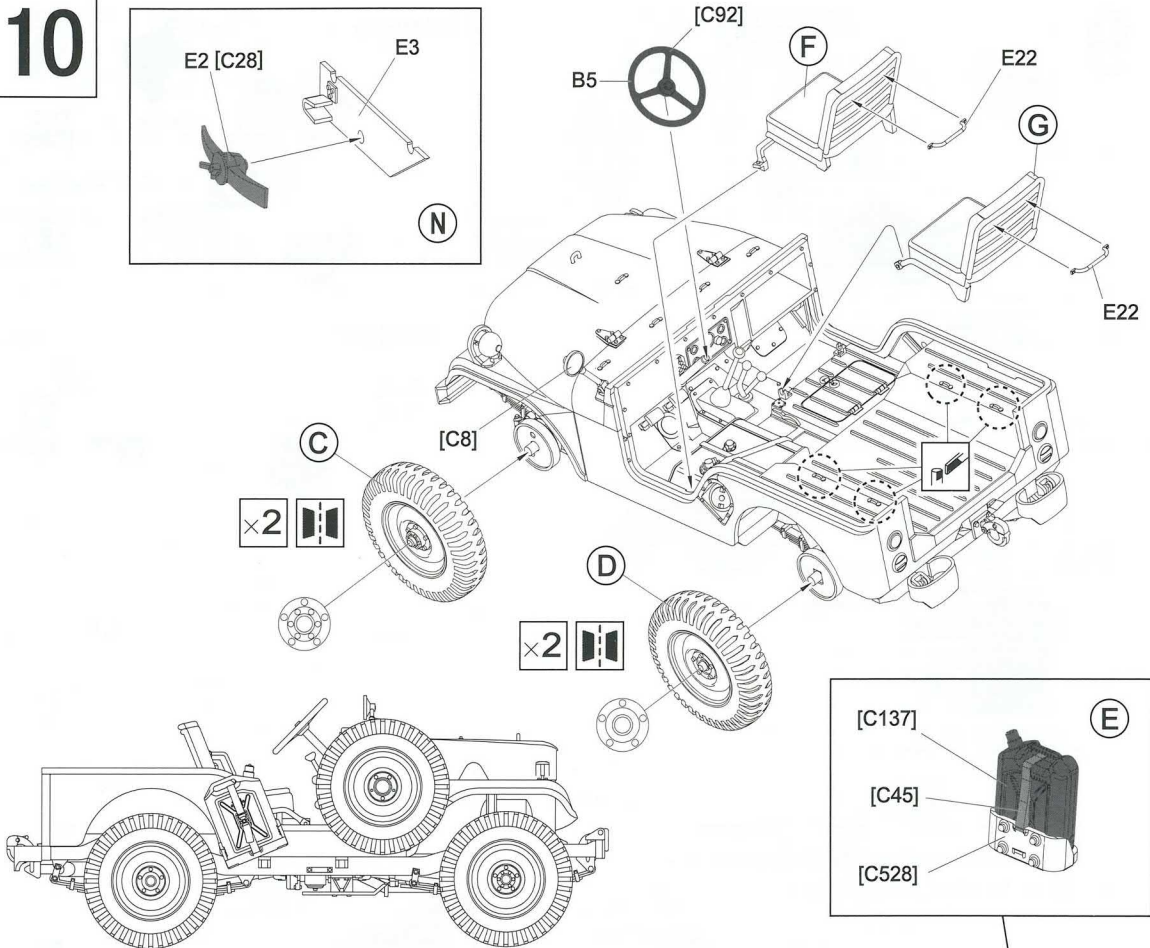
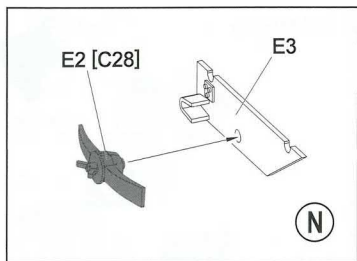



 製作射擊狀態時需在此步驟安裝C7板件。
The C7 travel lock assembly only for building up the shooting status.

11

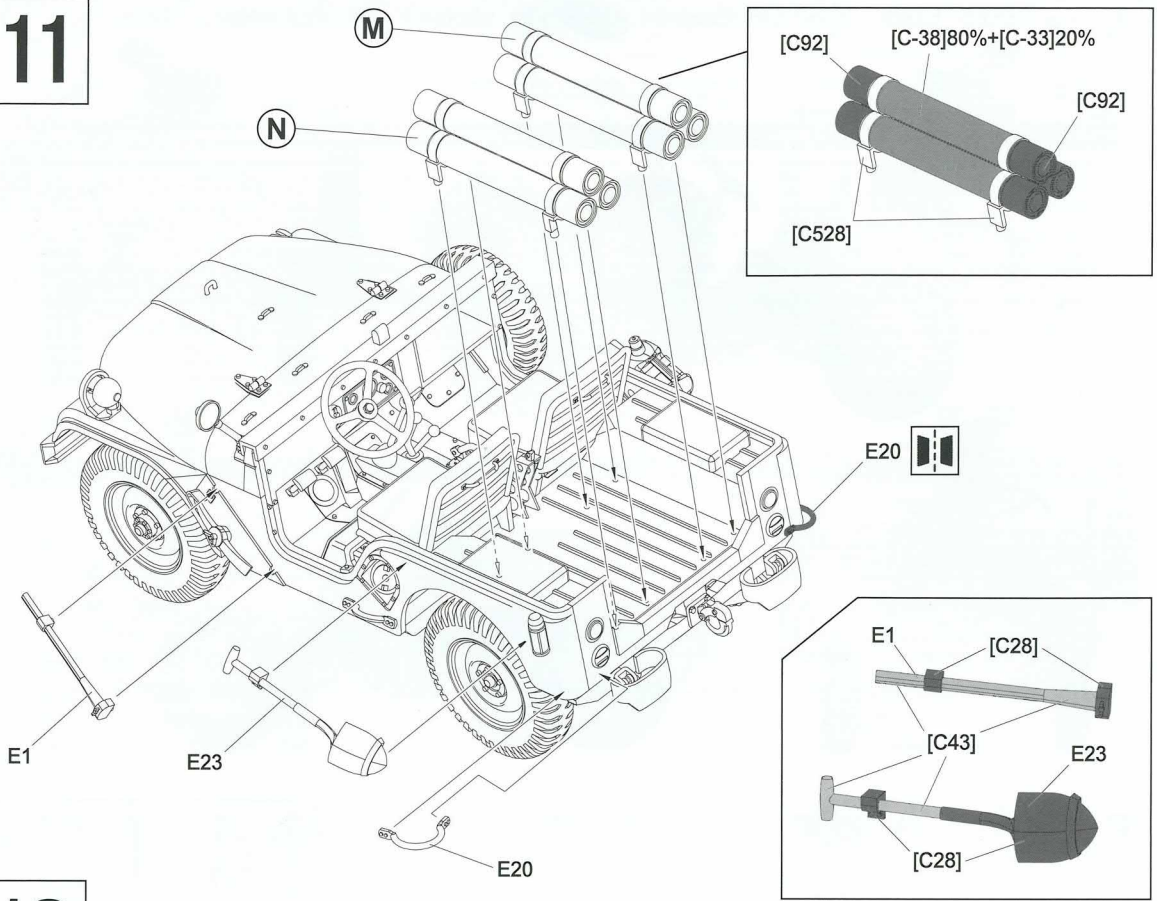

12

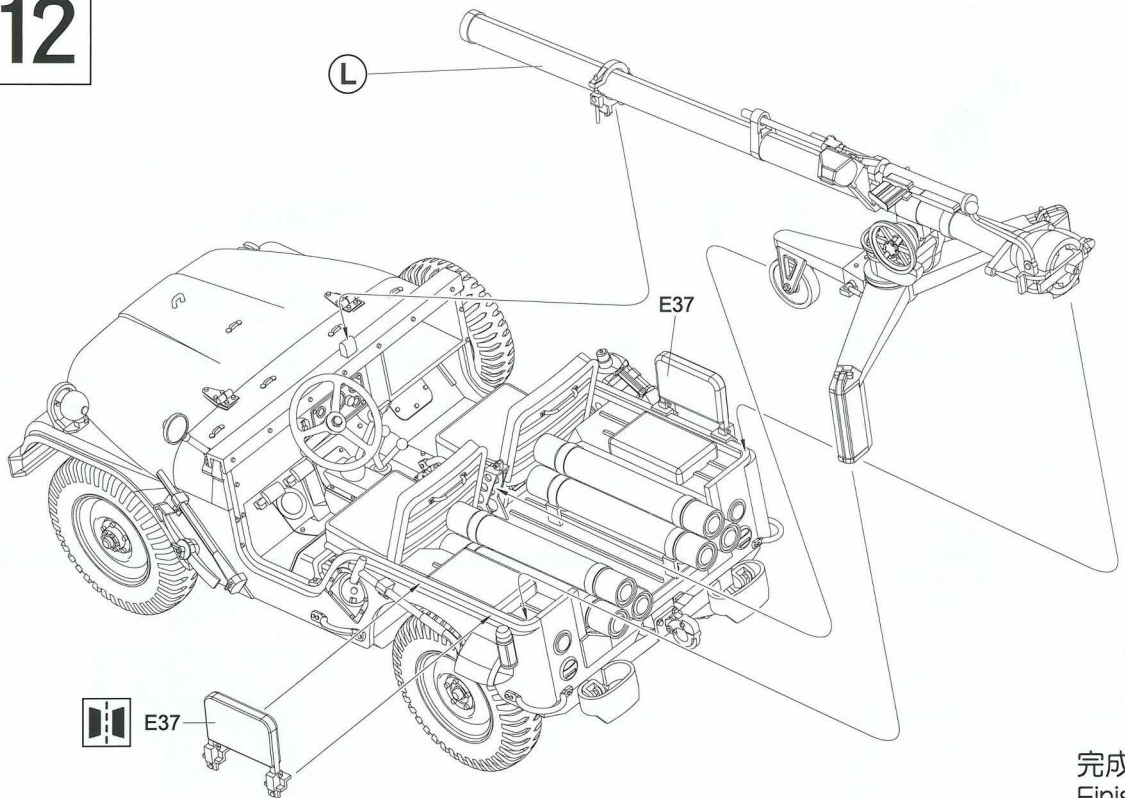

完成
Finish

A  Body Color:  IDF Gray 1  Flat black  Flat white

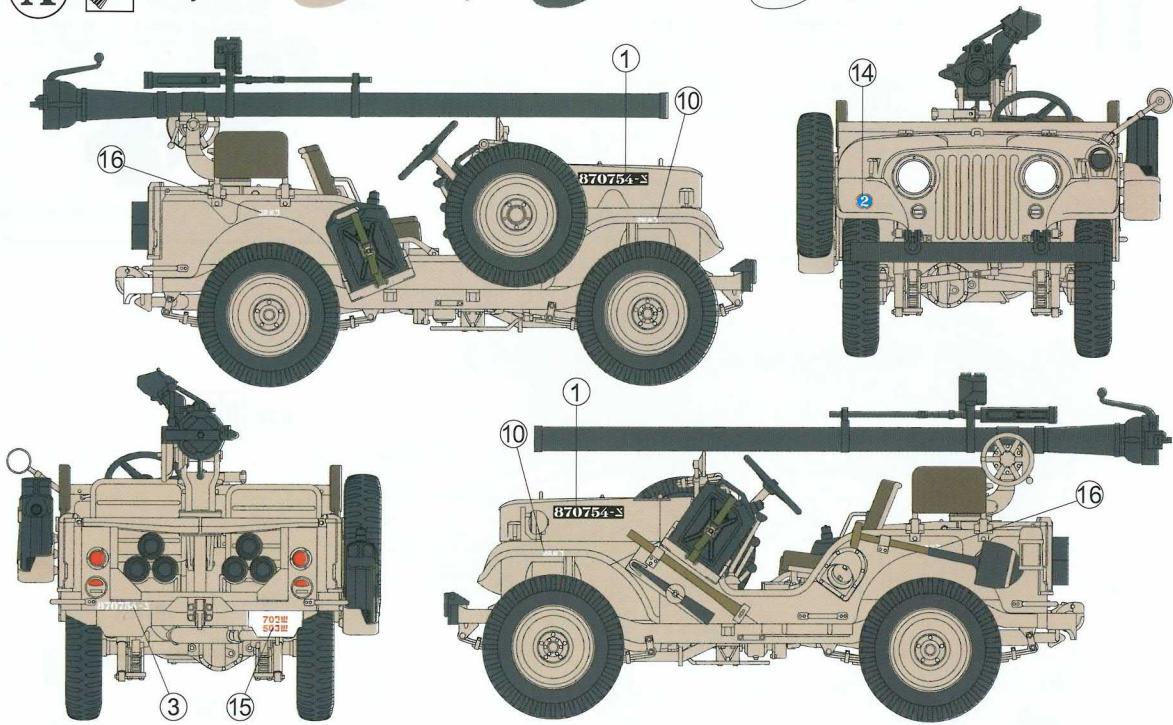



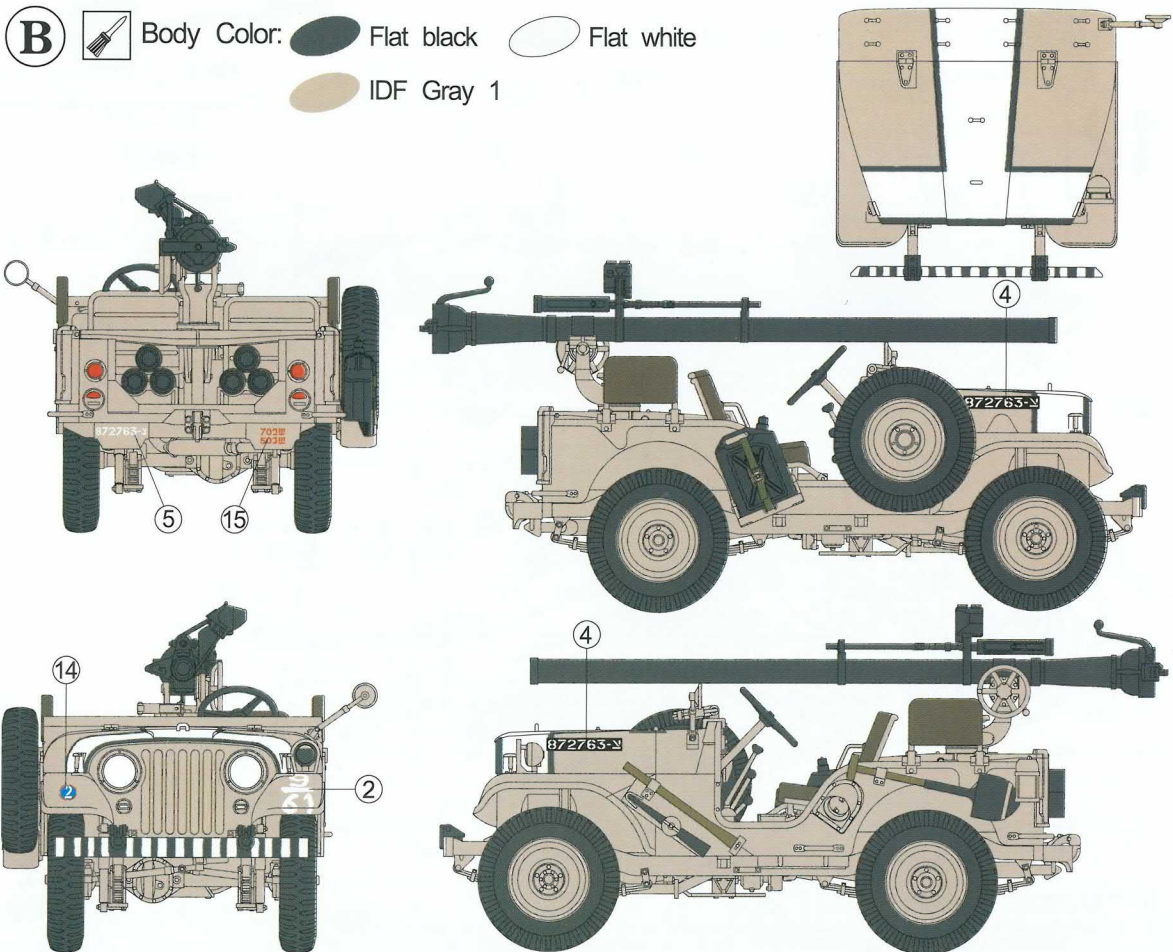

B  Body Color:  Flat black  Flat white  IDF Gray 1

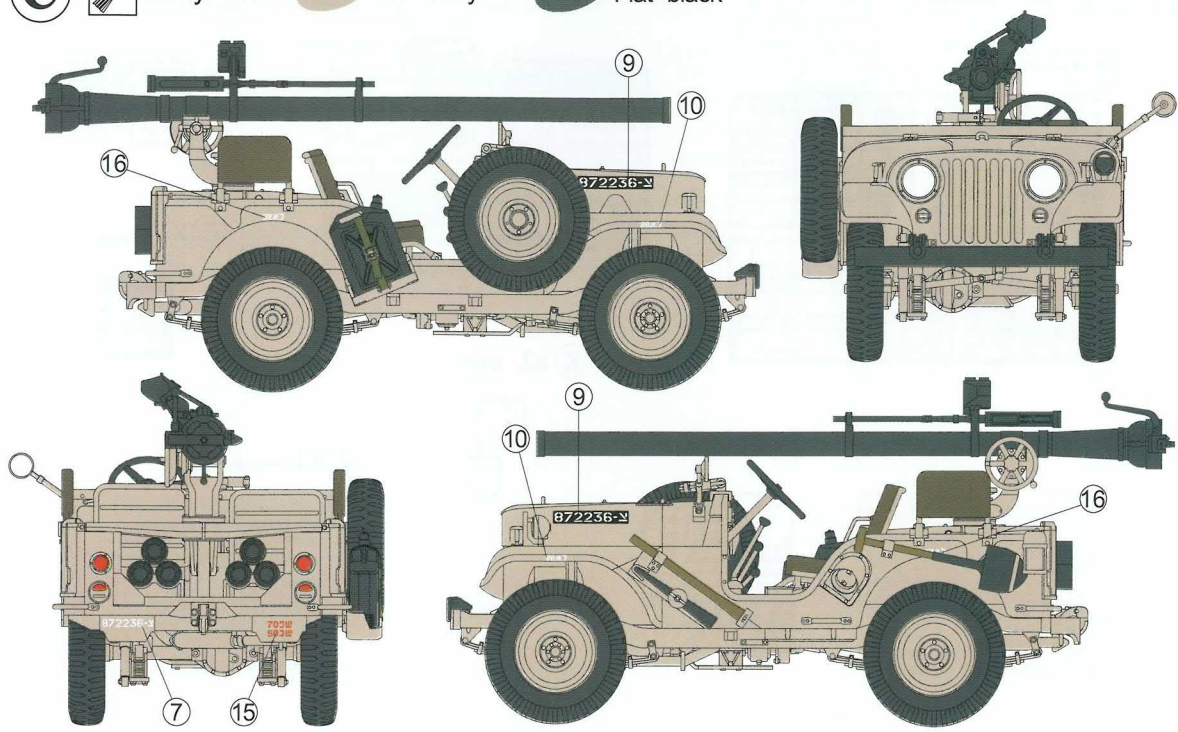

C  Body Color:  IDF Gray 1  Flat black



D  Body Color:  Flat black  Flat white  IDF Gray 1

