

VOUGHT OS2U KINGFISHER

Plastic model

scale : 1/72

History in brief

The first 54 Kingfishers were delivered to the U.S. Navy beginning in August 1940 and six had been assigned to the Pearl Harbor-based Battle Force before the end of the same year. Many of the following 158 OS2U-2s were attached to flight training at Naval Air Station Pensacola, Florida, but 53 were assigned to equip the newly established Inshore Patrol Squadrons, based at NAS Jacksonville, Florida. In 1942, nine more Inshore Patrol Squadrons were established, all exclusively equipped with OS2N-1s built by the Naval Aircraft Factory. The Kingfisher was widely used as a shipboard, catapult-launched scout plane on U.S. Navy battleships, heavy cruisers and light cruisers during World War II, as well as playing a major role in support of shore bombardments and air-sea rescue. Two examples showing the plane's rescue capabilities include the recovery of World War I ace Eddie Rickenbacker and his crew from the Pacific in November 1942 and Lieutenant John A. Burns' unique use of the aircraft on 30 April 1944 to taxi airmen rescued from Truk Lagoon to the submarine Tang, which was serving rescue duty near the atoll on that date. In all, LT Burns rescued 10 survivors on two trips and was awarded the Navy Cross for his efforts. Australia received 18 Kingfishers from a batch of aircraft ordered by the Dutch East Indies that was diverted to Australia in 1942. They were initially used as training aircraft for pilots destined for flying boats, but in 1943, they were used to equip No. 107 Squadron RAAF, which carried out convoy escort duties until disbanded in October 1945. One Kingfisher was used in support of the Australian National Antarctic Research Expedition in 1947-48. Throughout its U.S. Navy service, the OS2U and even its predecessor, the Curtiss SOC Seagull served much longer than planned, as the planned successor, the Curtiss SO3C Seamew, suffered from an insufficiently powerful engine which was a complete failure. The OS2U was only slowly replaced in the latter stages of World War II with the introduction of the Curtiss SC Seahawk, the first examples reaching the U.S. Navy in October 1944.

Plastic parts

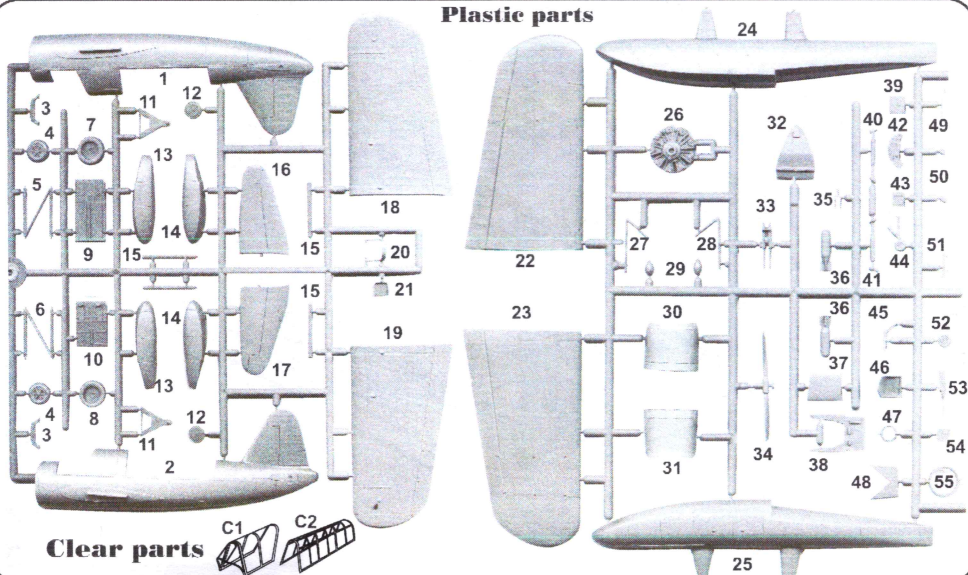

Clear parts



Symbols/Symboly

Drill hole	Cyanocrylate	Remove	Reduce
Vyvrtat	Vlepinové lepidlo	Odstranit	Zbrousit
Make new	Option	Bend	Putty
Vyrobít	Volba	Ohnout	Tmel

	Colour name	Humbrol	Colour name	Humbrol
A	Black	H33	F Tyre	H85
B	Interior Green	H76	G Silver	H11
C	Aluminium	H56	H Rust	H113
D	Gunmetal	H53	I White	H34
E	Leather	H62	J Light Sand	H121

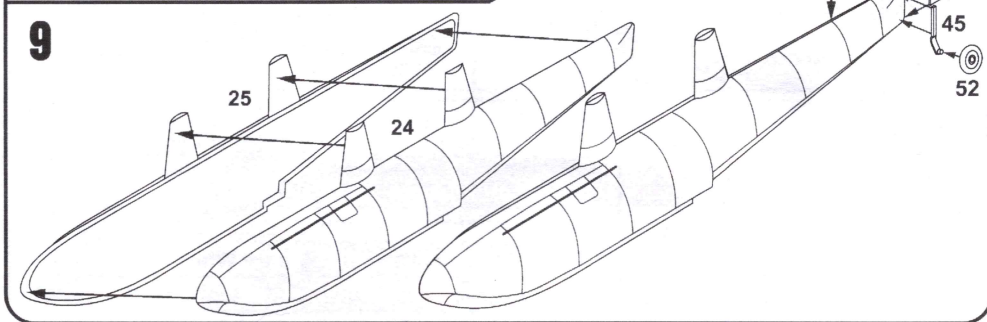
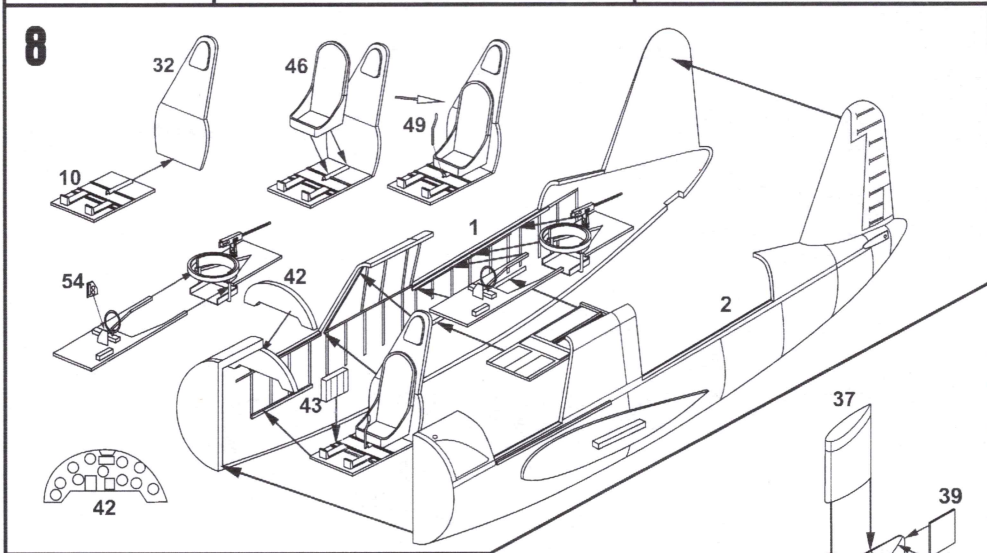
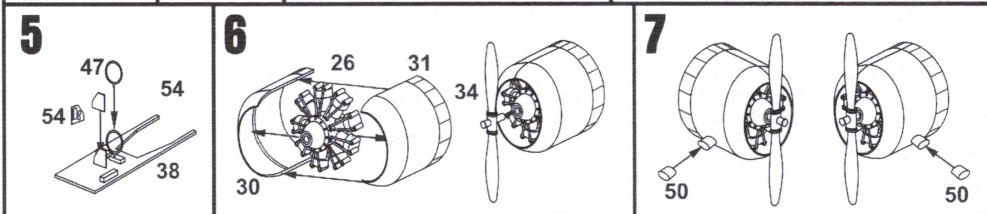
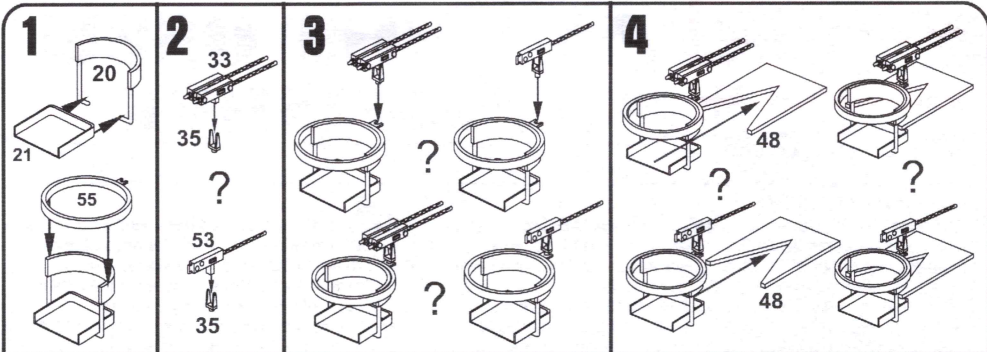

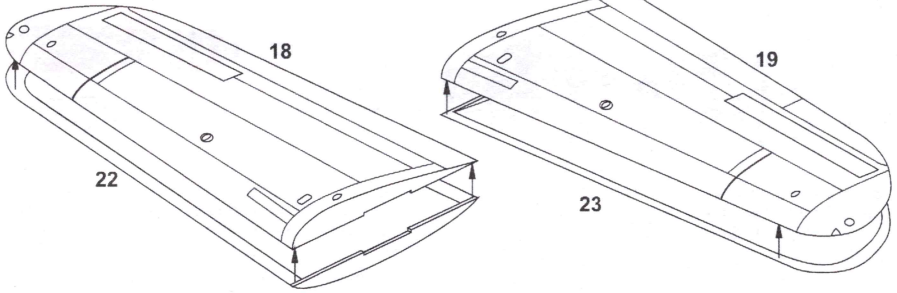
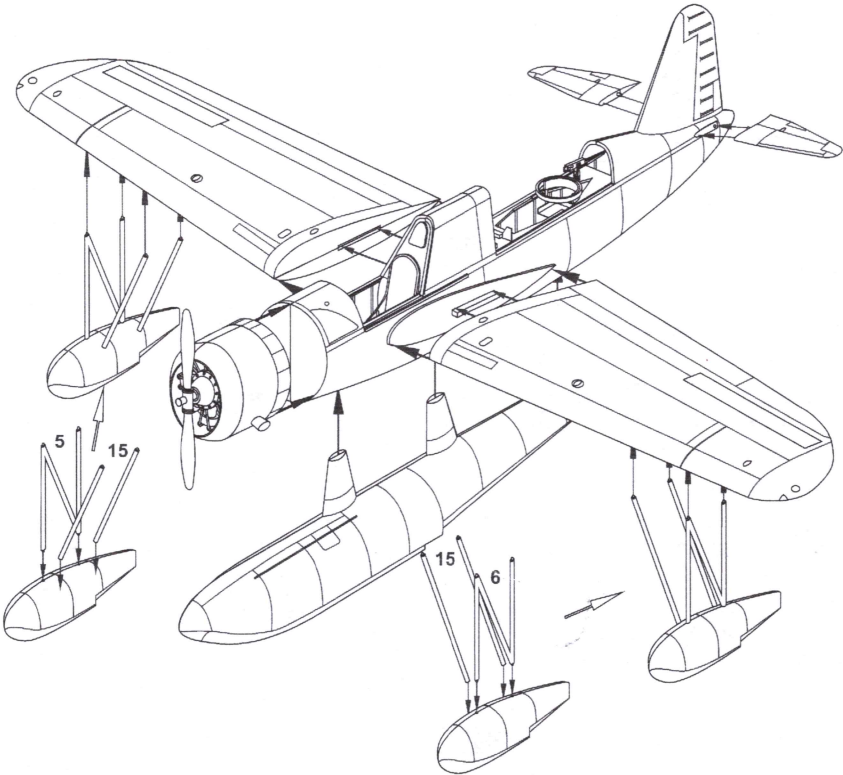
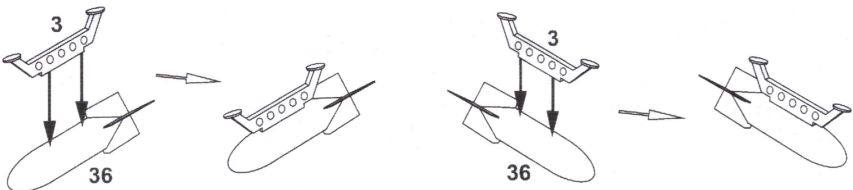
10**11****12**

13

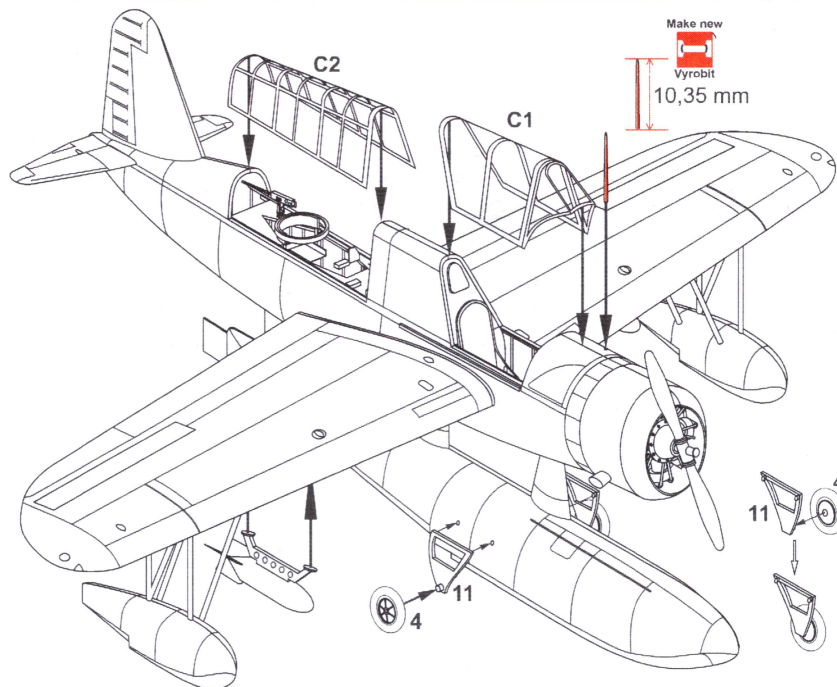

14

Make new



10,35 mm

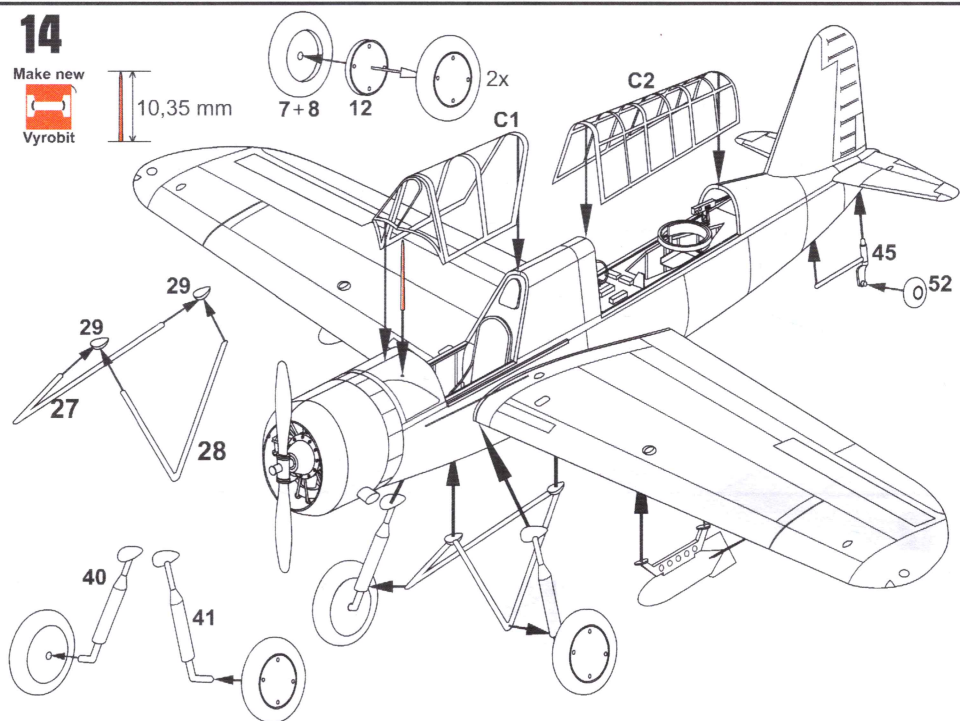



5



5



5



2



8



14



14

1

I-O-I

6

102

11

U.S.NAVY

11

U.S.NAVY

3

I-O-I

4

5D4-S-1

102

102 102

5D4-S-1

9

12 2190 2190

OS2U-2 OS2U-2 13 7

10

OS-2 „Kingfisher“
US floatplane



15

AZ model

Colours & Markings

- 1** Kingfisher 1-0-1, aboard USS Arizona, Pearl Harbor, 7th December 1941
Plane which was aboard Arizona during the Japanese attack on Pearl Harbor

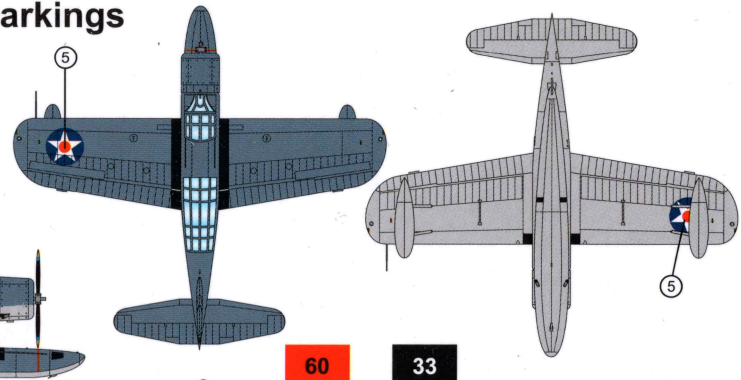
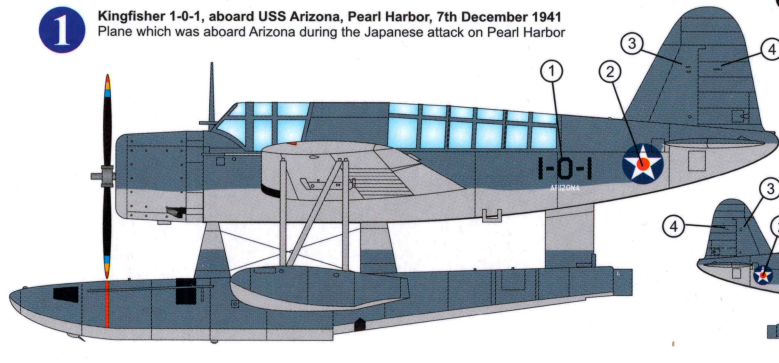

- 2** Kingfisher 102, NAS Corpus Christi, 1942
The most colourful Kingfishers were naval trainers, which retained Chrome Yellow wing tops. Illustrated is one of them.

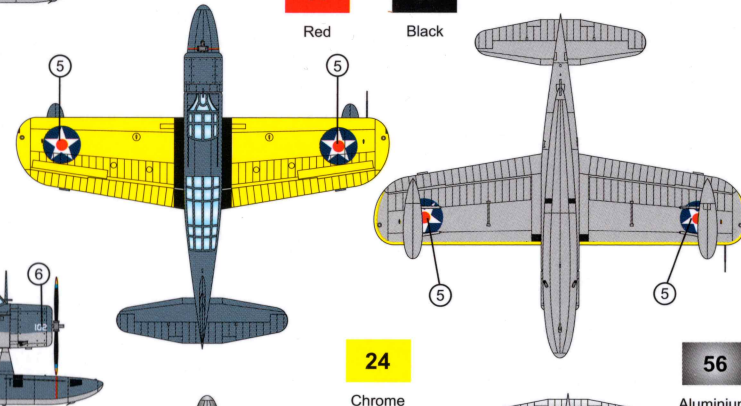
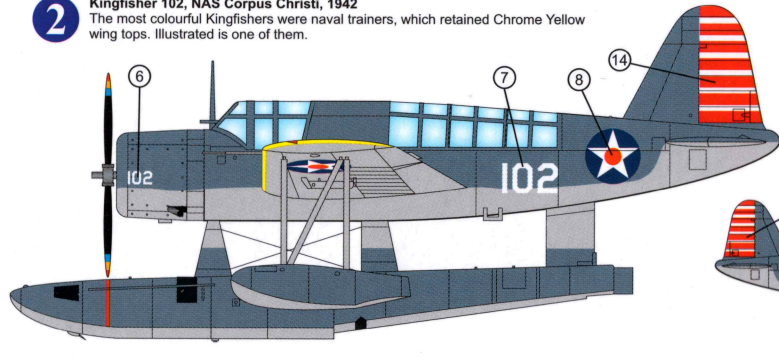

60
Red

33
Black

- 3** Kingfisher 5D4-S-1, NAS Cape May, 1941
Plane in typical pre-war scheme. Note star on cowling, used by aircraft used for neutrality patrols.

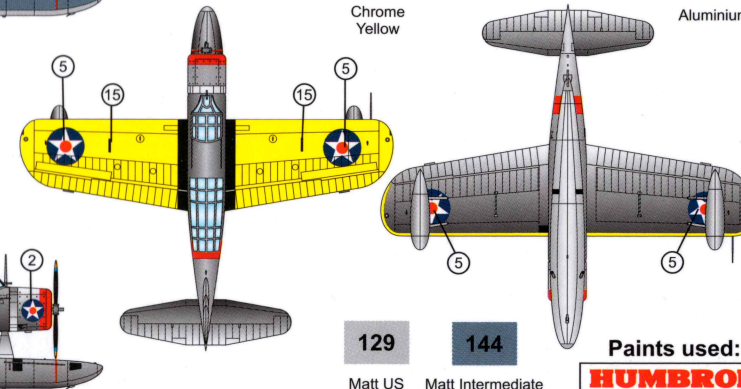
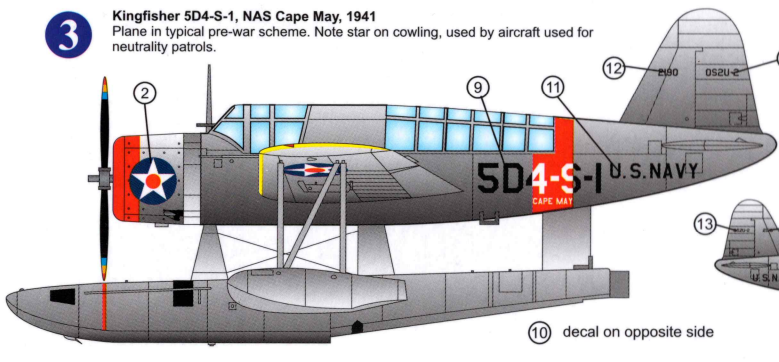

24
Chrome
Yellow

56
Aluminium

129
Matt US
Gull Grey

144
Matt Intermediate
Blue

Paints used:
HUMBROL

AZmodel
Plastic kits

UNASSEMBLED PLASTIC MODEL KIT.
CEMENT AND PAINT NOT INCLUDED.

Box contains: Plastic parts
Decal sheet for 3 versions
Colour instruction

1:72
SCALE MODEL KIT
No. AZ 7636



Vought **Kingfisher**

F180 X 2019