

German Sd.Kfz.7/2 3.7cm Flak 43 Auf Selbstfahrlafette

德国Sd.Kfz.7/2 八吨半履带Flak 43 3.7cm自行防空炮



READ BEFORE ASSEMBLY:

- Study and understand these instructions thoroughly before beginning assembly
- When needed, remove photo-etch parts carefully using a modeling knife or photo etch sprue cutter, being careful not to damage or lose small parts.
- Take extra care in handling photo etch parts in order to avoid injury
- Apply instant cement sparingly to photo etch parts where instructed
- Tools recommended(not included in kit):Plastic and instant cements, sprue cutters,long nose pliers,modeling knife, small files, tweezers, pin vise & scissors. Soft cloth and sandpaper will also assist in construction
- Glue and paint are not included in the kit. Use plastic cement and hobby paints only. Color guide for purchasing paint is included in the kit.

装配之前仔细阅读

- 小心用模型锉刀锉平所有零件表面的注射浇口。
- 小心用刀片切下蚀刻片零件，不要遗失小零件。
- 用强力快干胶水粘合蚀刻片零件和金属轴。过量快干胶水使用可能导致可动零件会粘住，小心涂胶。
- 取蚀刻片时应特别注意安全，防止利边划伤手指。
- 某些零件表面需贴水贴纸，请选择在装配的同时进行。
- 推荐模型工具(自备)：胶水，水口剪刀，长咀钳，刀片，锉刀，镊子，钳，钻，剪刀，瞬间快干胶。
- 软布同砂纸同时也应该是必备工具。
- 请使用塑料胶水和油漆，模型内不含。



配重
Weight



使用强力胶
Cyanoacrylate glue



钻孔
Make hole



切除
Cut / Remove



贴纸
Decal



锉平
File / Sand



选择
Option



不涂胶水
No cement



弯曲
Bend

水贴纸的使用:

- 1.从水贴纸上剪下印花;
- 2.将印花放入温水中浸10秒, 然后放在干净布上。
- 3.拿着印花纸板将印花移到模型上;
- 4.手指蘸水将印花移到适当的位置;
- 5.用软布轻压印花直至水干, 气泡消失

DECAL APPLICATION

- 1.Cut decals from sheet as needed
- 2.Dip the decal in warm water for about 10 seconds and then place on soft clean cloth.
- 3.Hold the decal backing sheet edge and gently slide the decal onto the model in its proper position.
- 4.While still wet,decal can be adjusted for better fit on model by dampening it gently with your finger.
- 5.When placed in the proper position,gently press decal down with a soft cloth until excess water and air bubbles are gone.
- 6.Allow decal to dry completely before handling model

部品图
Parts

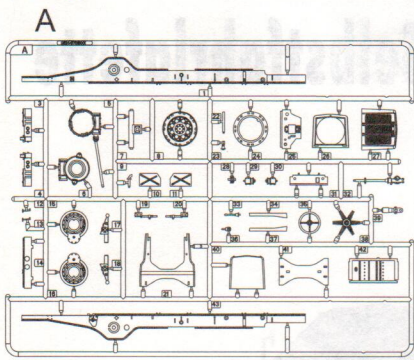

BX2

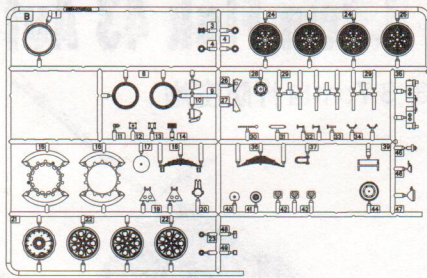

D

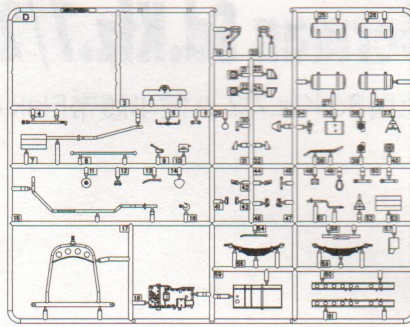

E

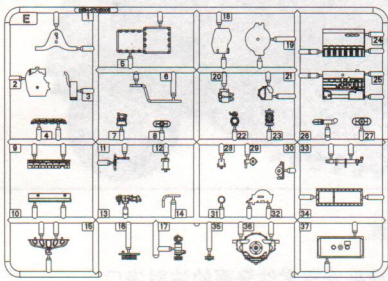

F

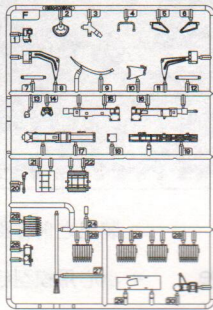

G

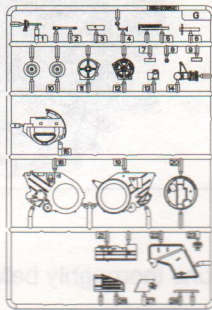

WA

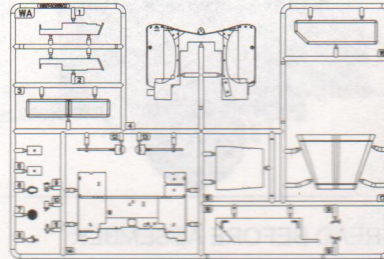

WB

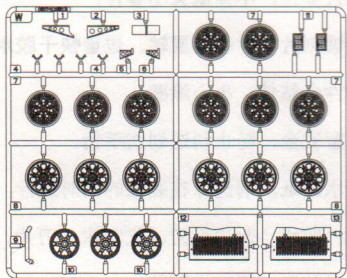

WI

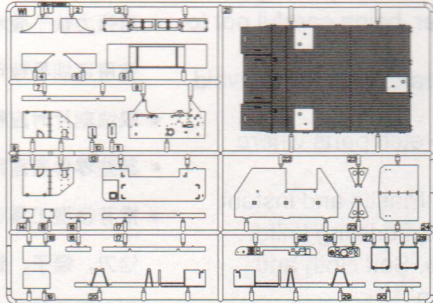

WJ

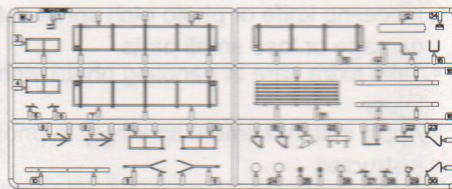

(轮胎)X3
Tire



(棉绳) Ø 0.6x1000mm
Rope



(铜丝) Ø 0.5x50mm
Wire



WP

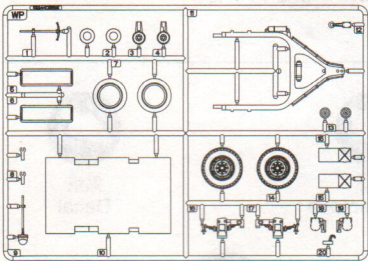

WQ

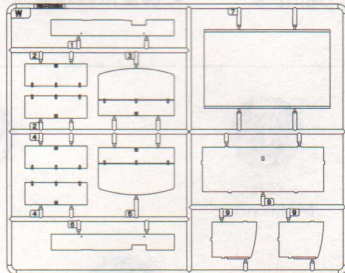

WM

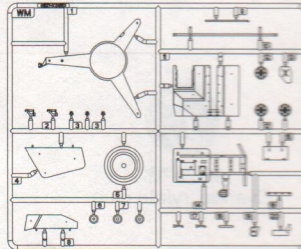

蚀刻片WE
PE-WE



蚀刻片WA
PE-WA

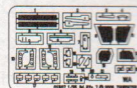

蚀刻片WJ
PE-WJ

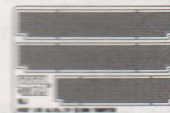

TRX6

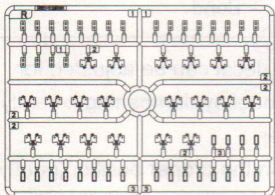

(驾驶室)
CAB

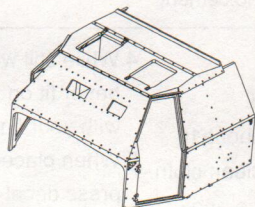

《水贴纸》
Decal



不用部品:A22.A13.A33.B14.B19.B23.B26.B27.B34.B46.D33.D49.D51.D52.G23.G27.WA12.WP1.WP9.WP15
Unused part:

1

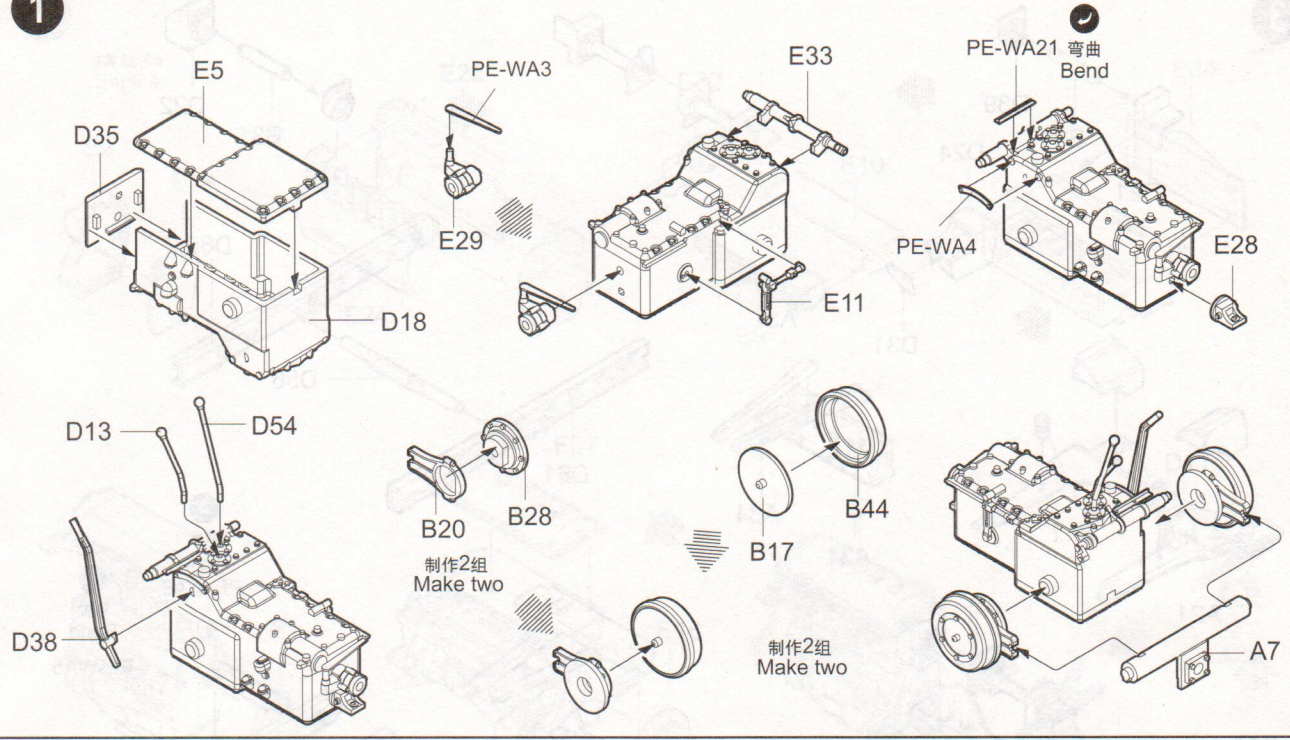

2

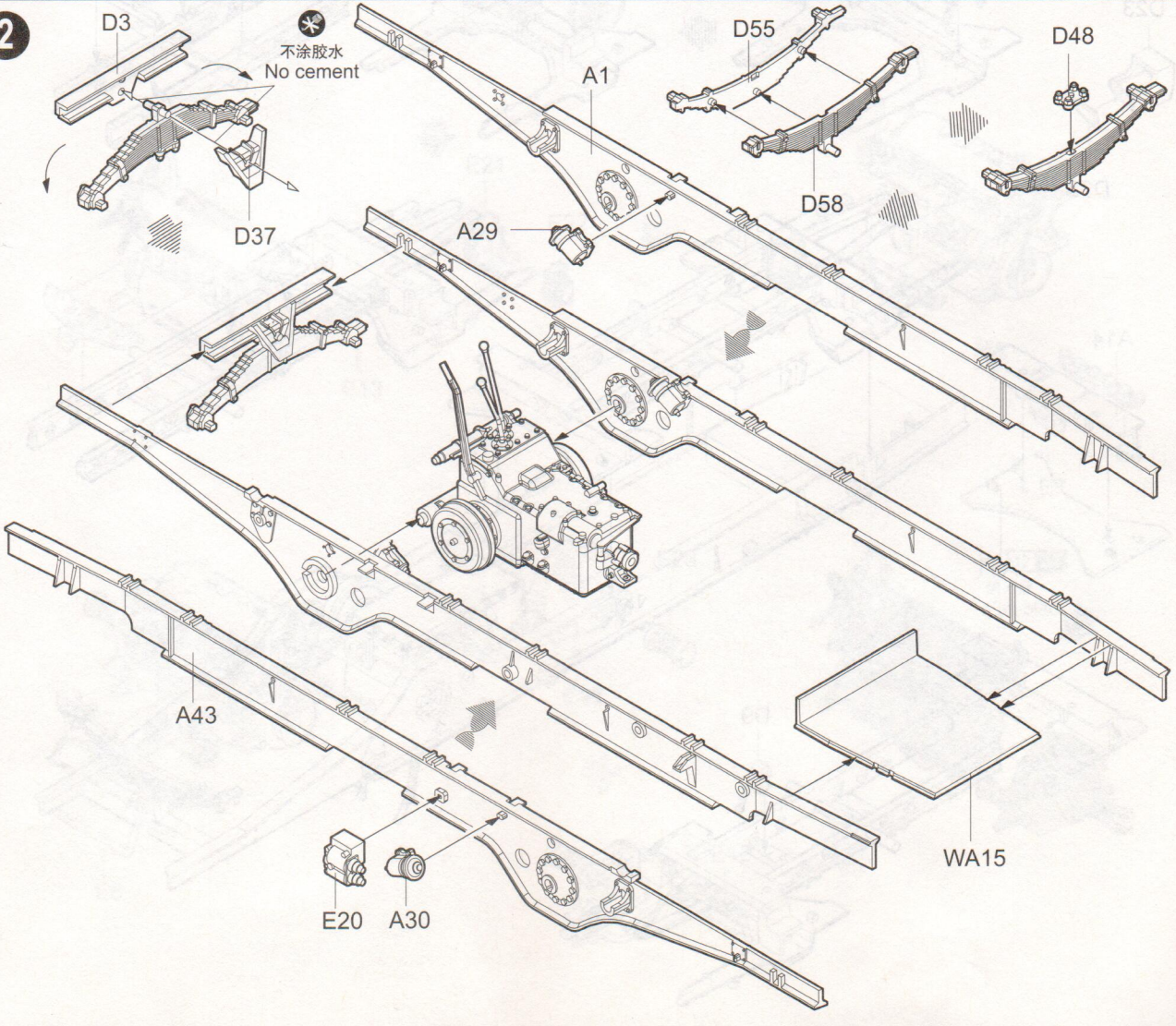

3

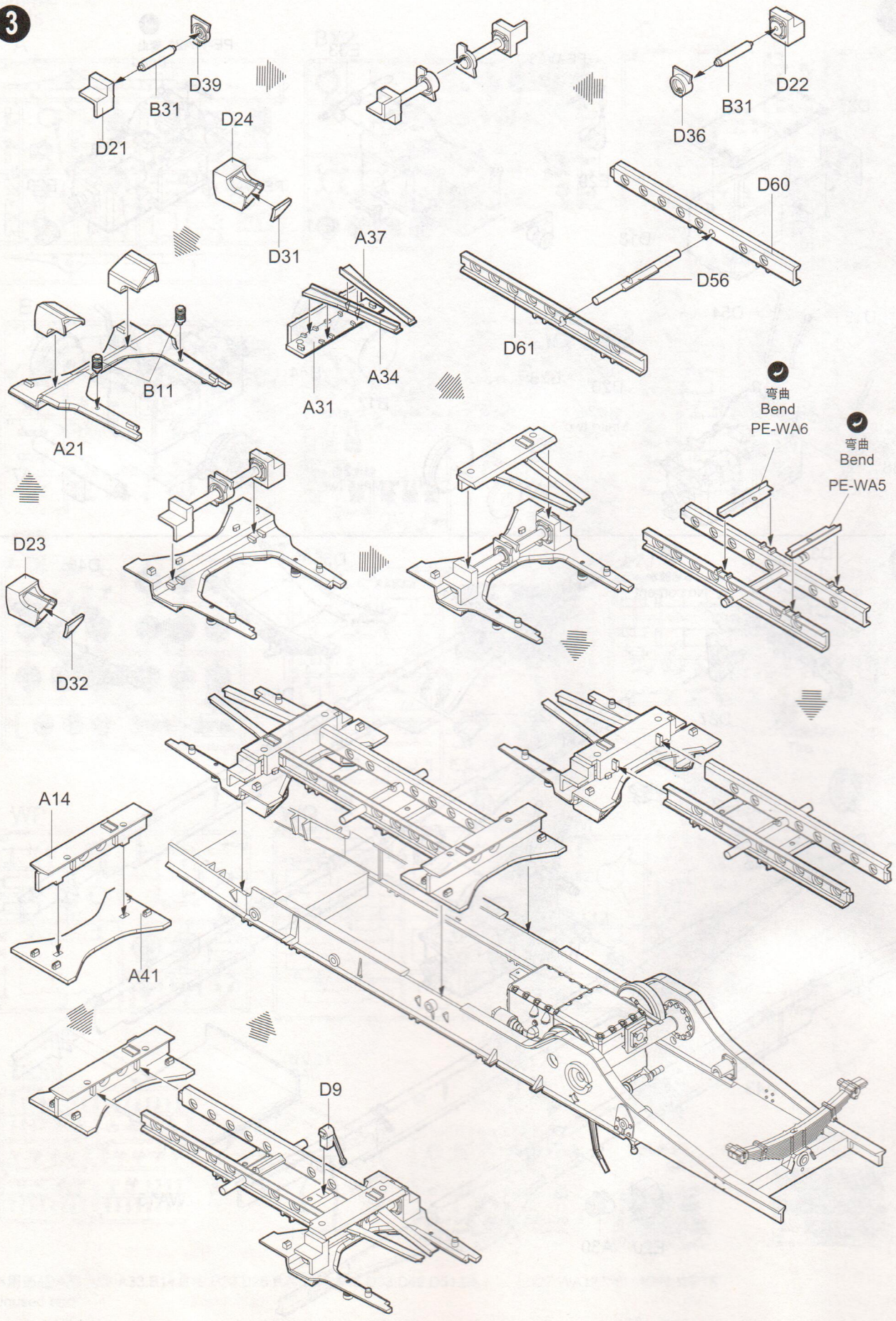

4



4

《发动机》
Engine

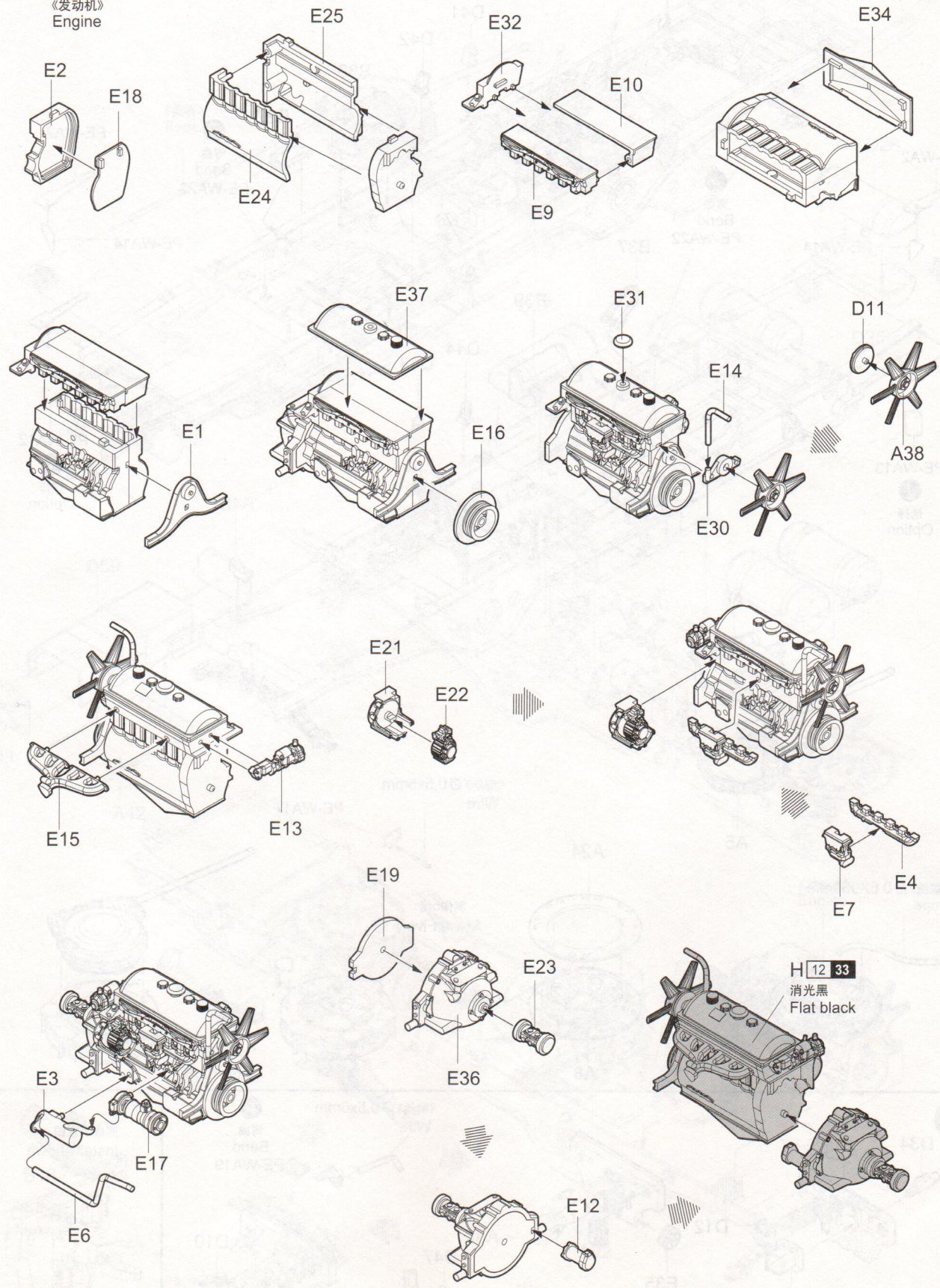

5

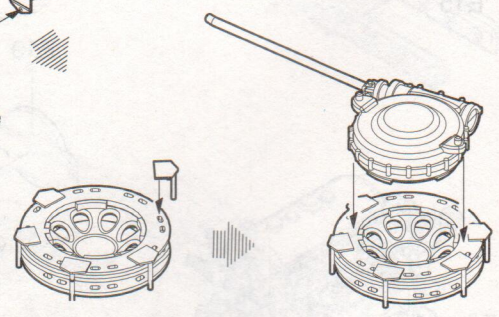
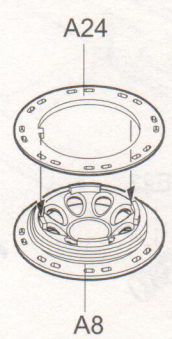
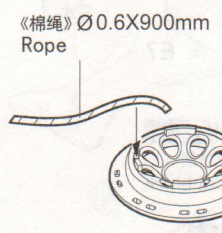
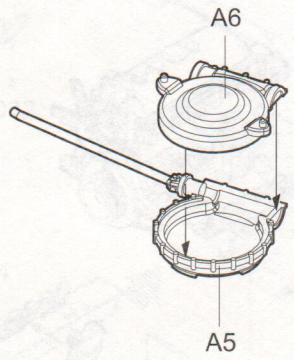
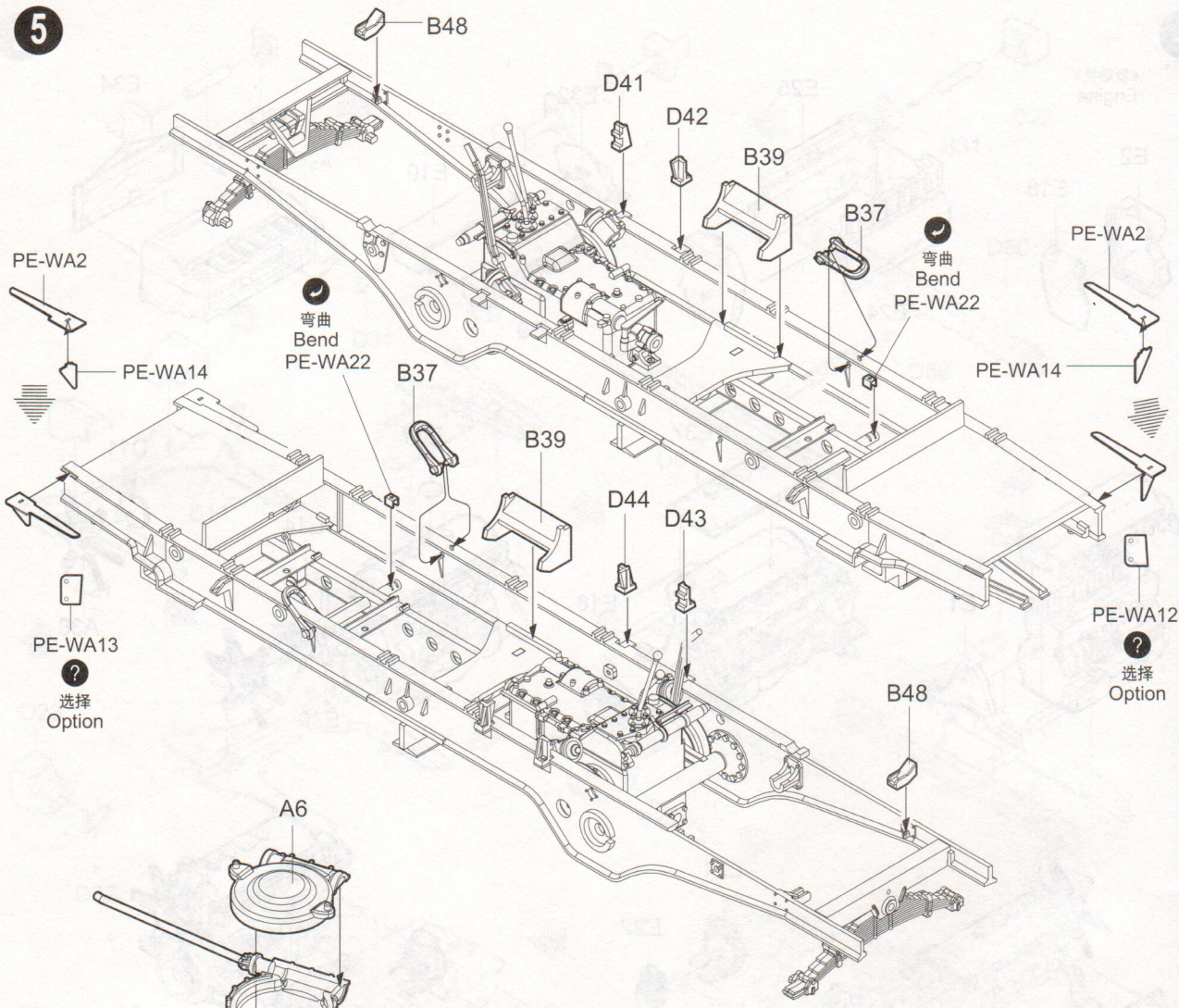

6

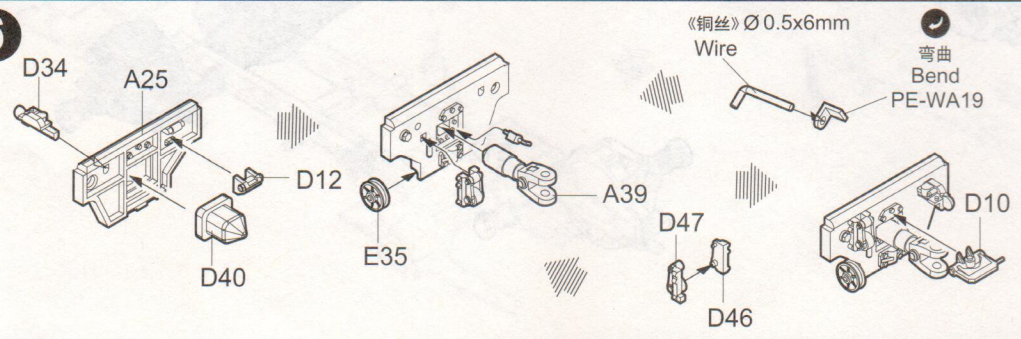

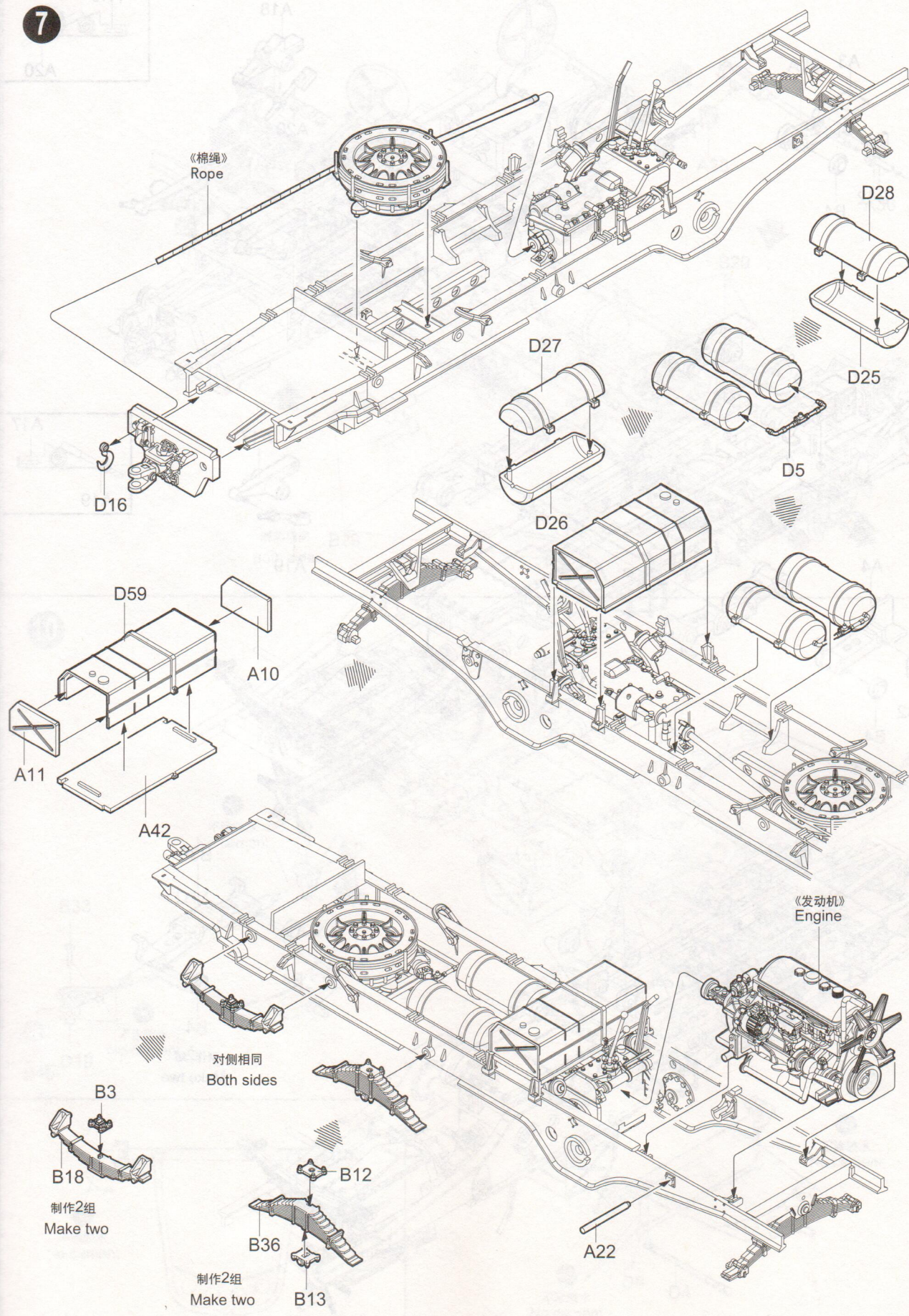

8

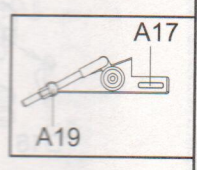
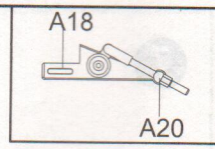
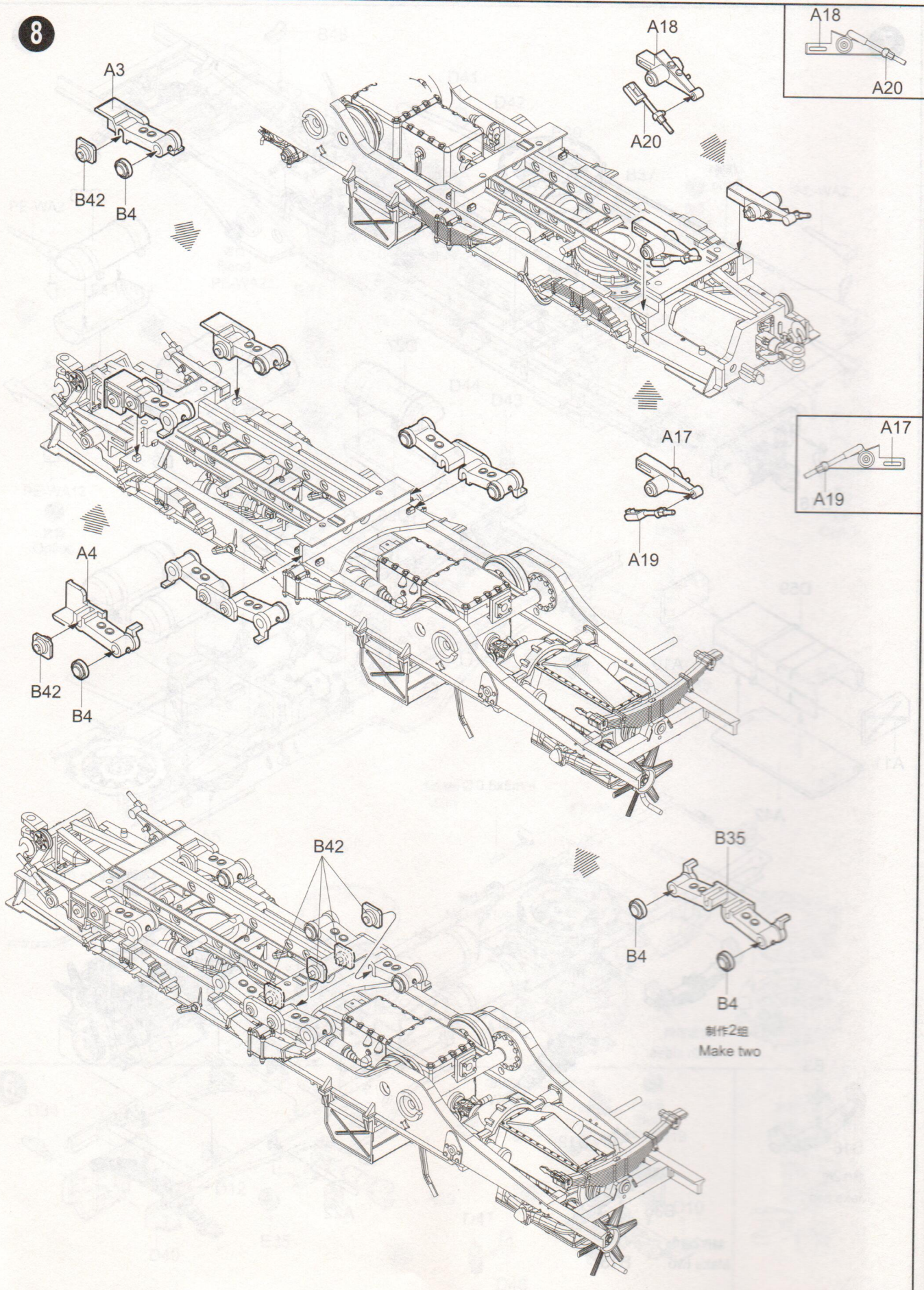

9

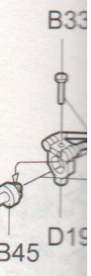

不涂油
No oil

9

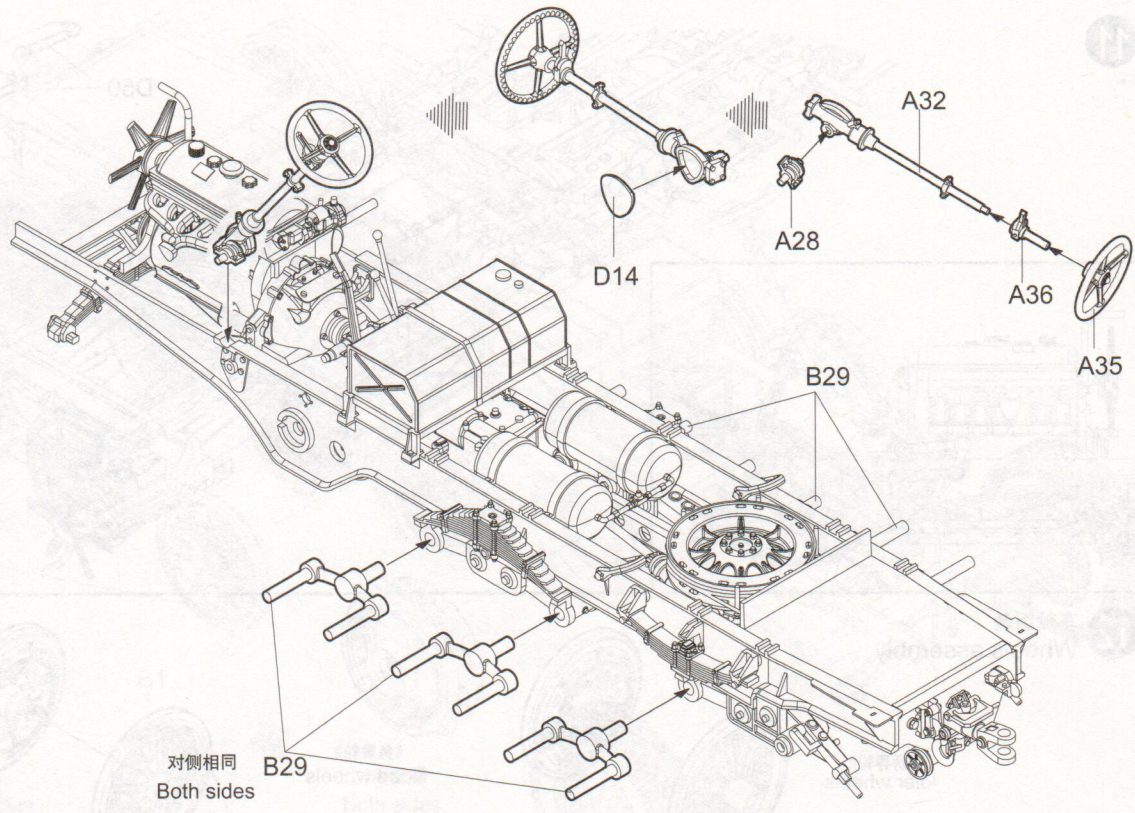

对侧相同
Both sides

10

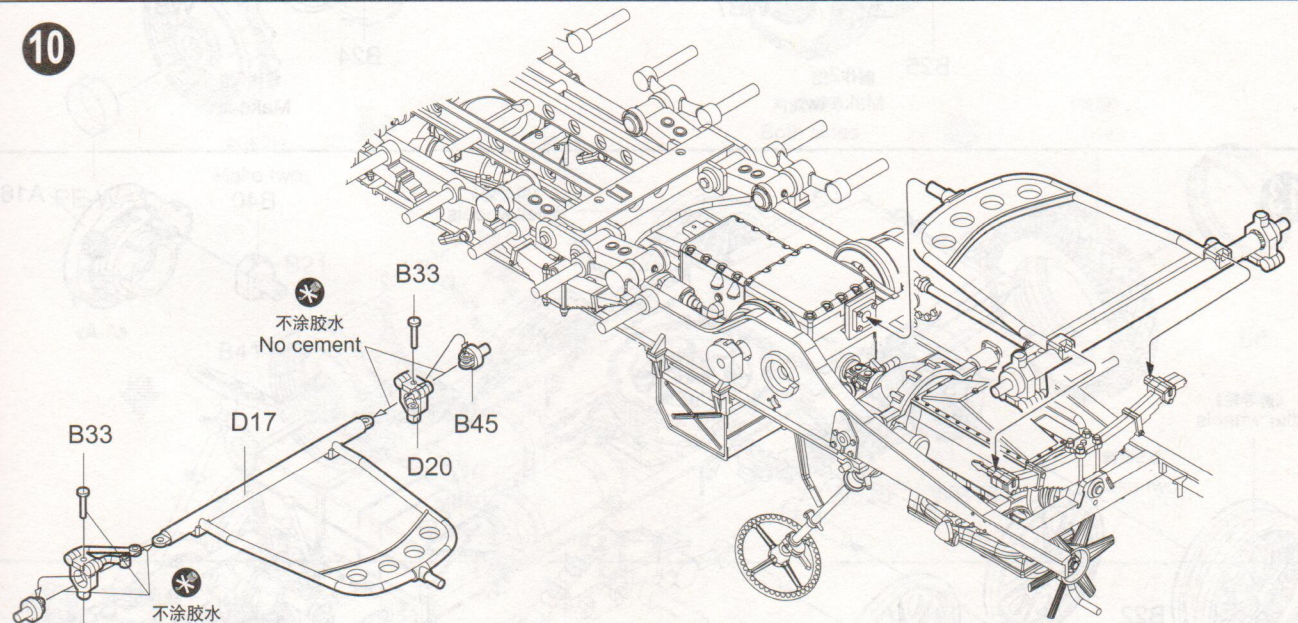

不涂胶水
No cement

不涂胶水
No cement

不涂胶水
No cement

不涂胶水
No cement

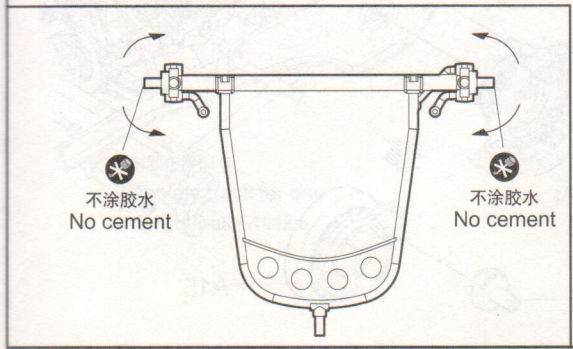

不涂胶水
No cement

不涂胶水
No cement

11

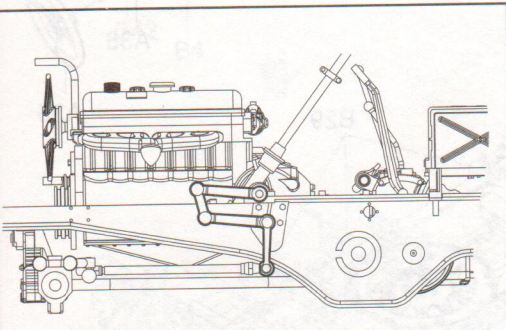
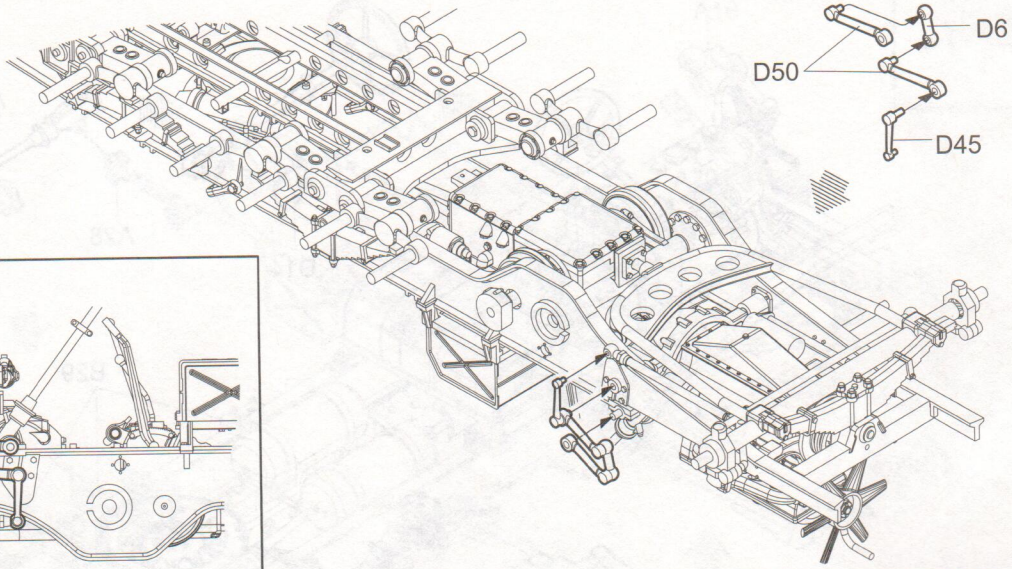

12 车轮组装
Wheels assembly



13

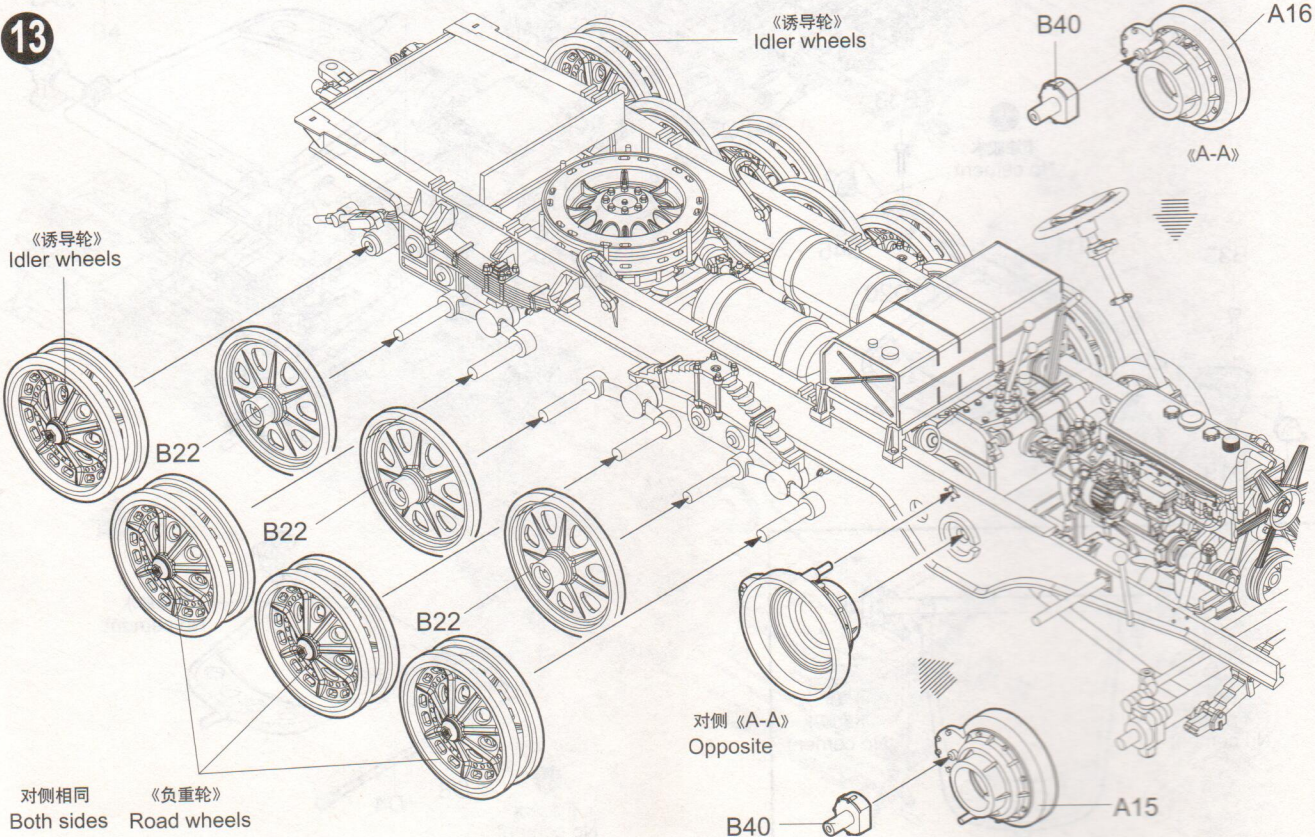

14



WB8
对侧相同
Both sides



PE-WA
弯曲
Bend

15

履带
Tra

单侧
Com
side

14

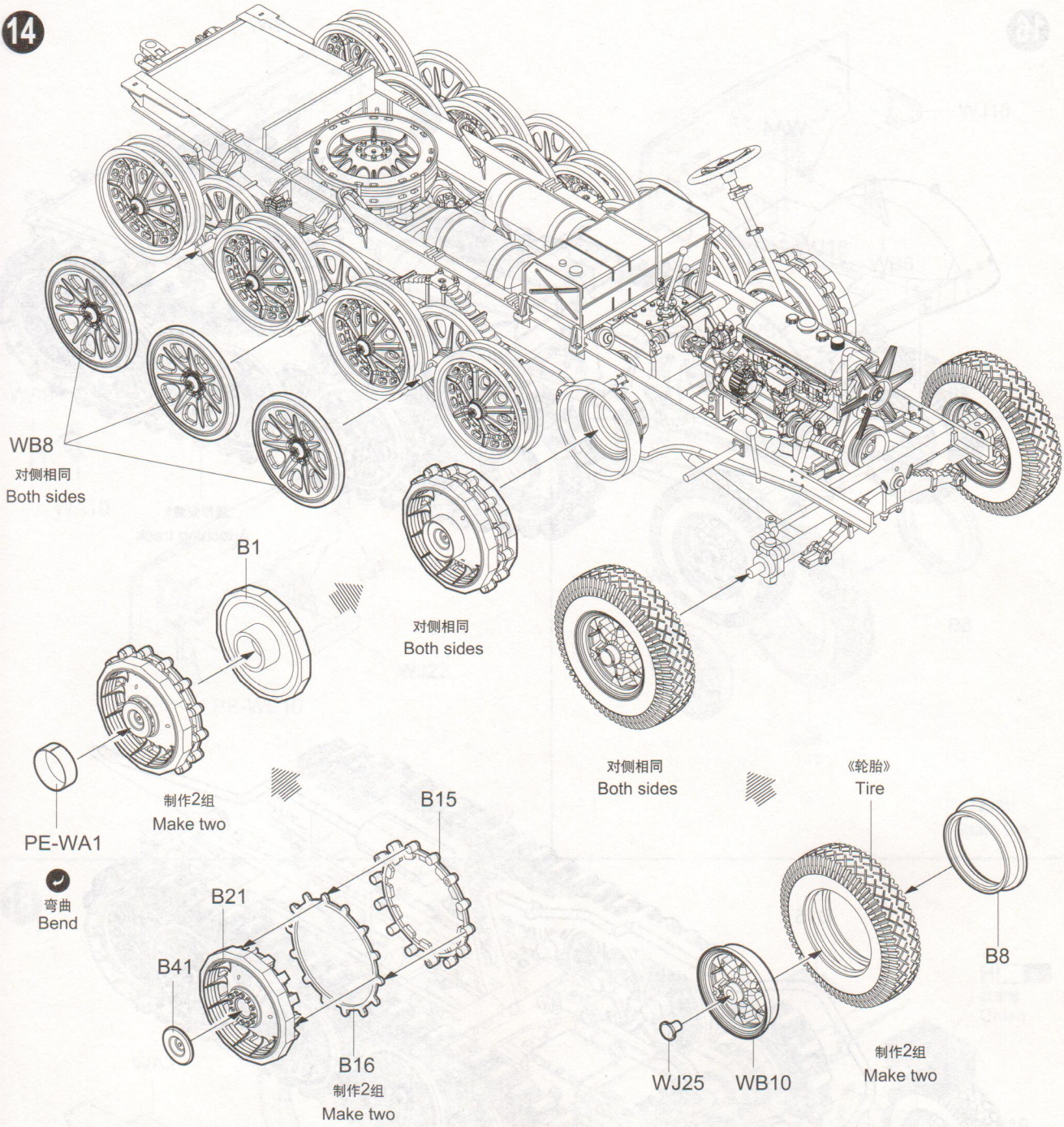

15

履带组装
Track assembly

单侧履带需54节
Complete track for one
side requires 54links

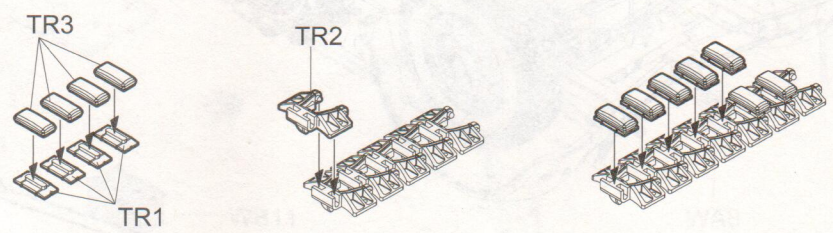

16

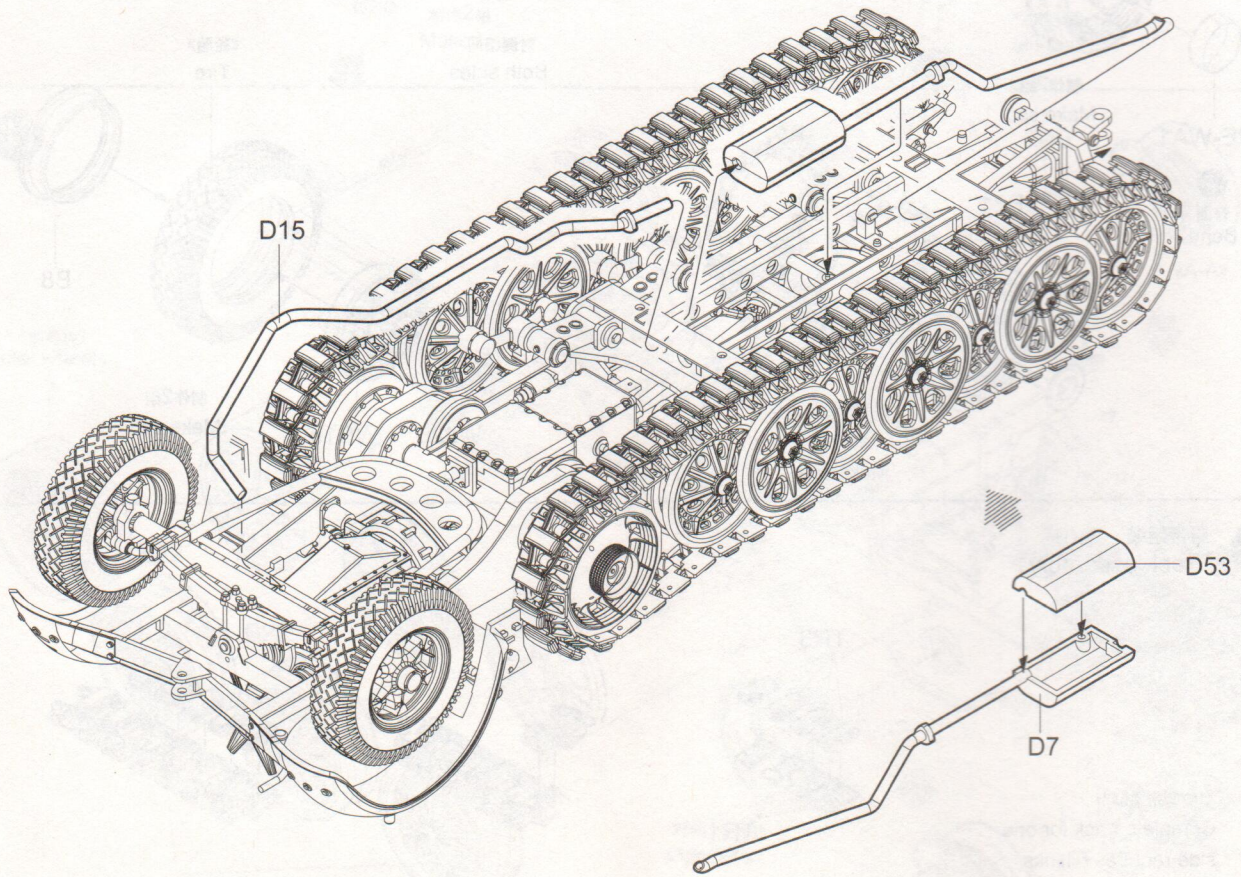
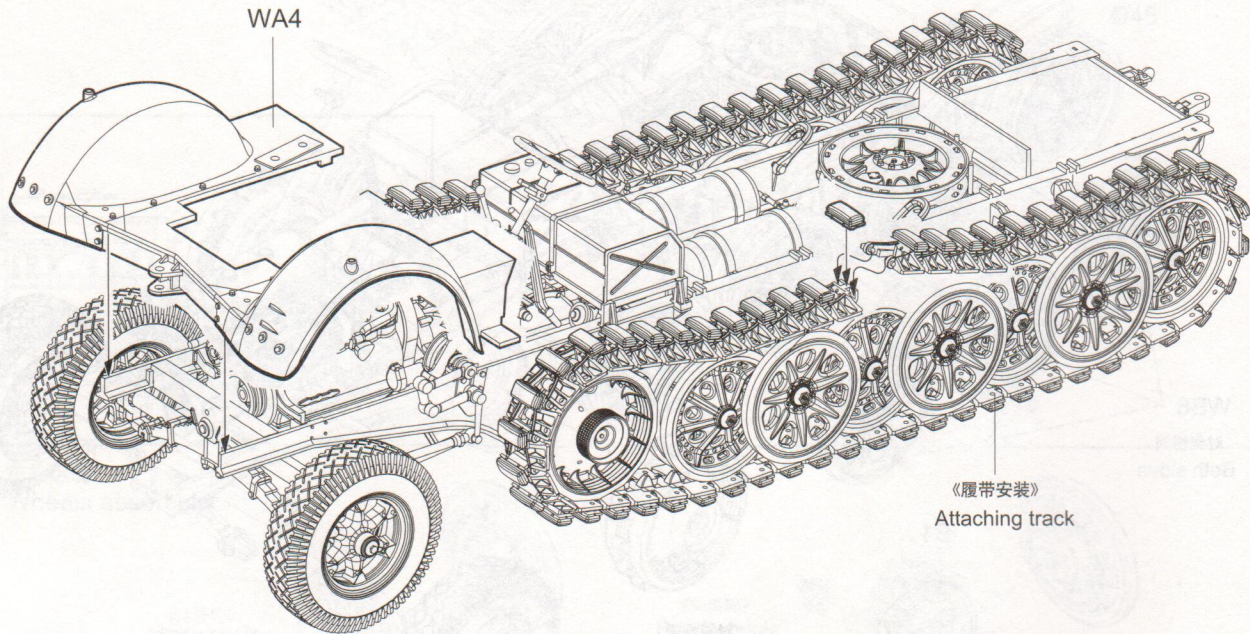

17



18



17

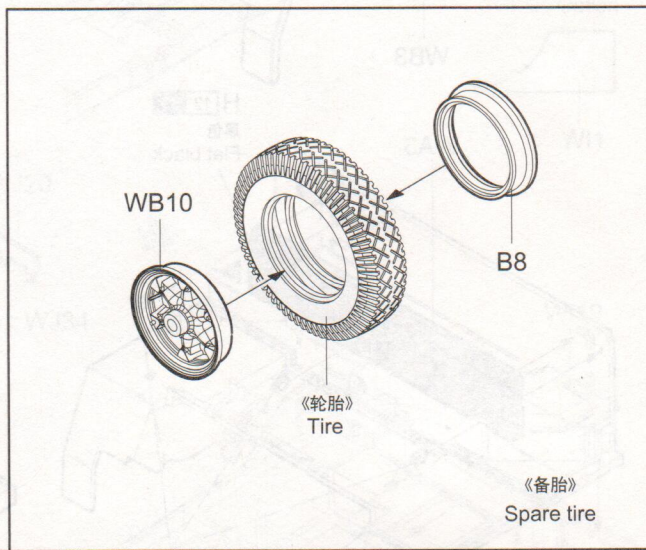
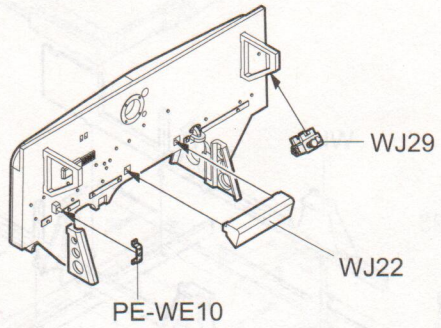
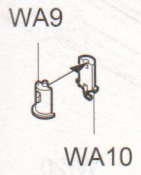
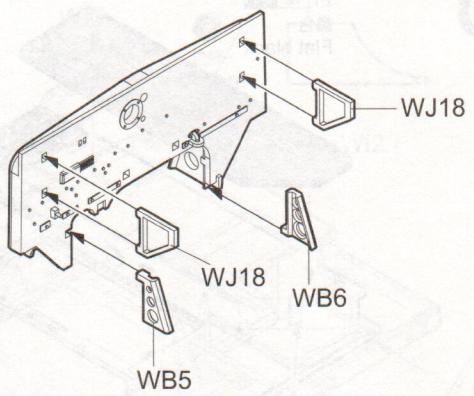
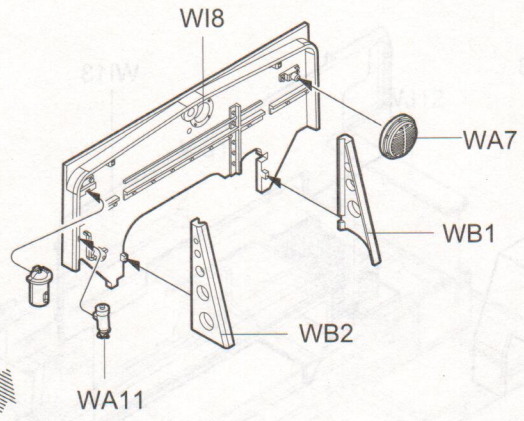

《B-B》

《备胎》
Spare tire

18

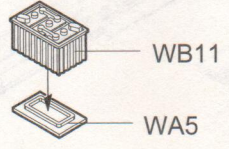
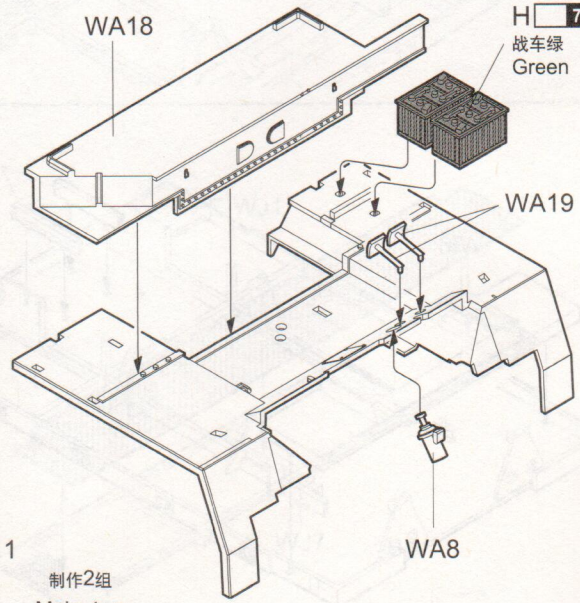
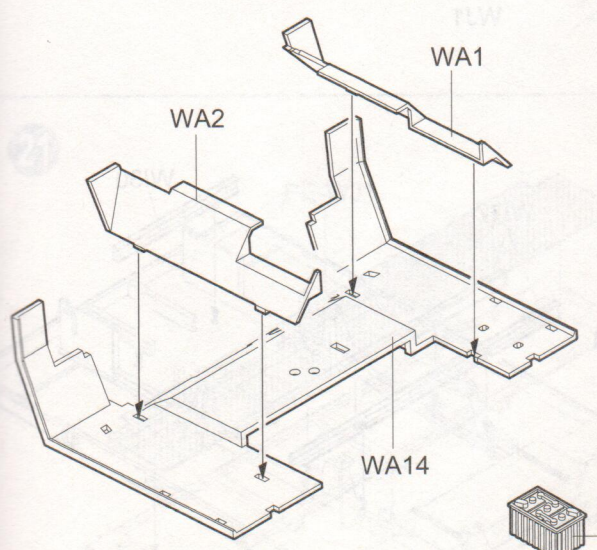

制作2组
Make two

19

H 12 33

黑色
Flat black

WA16

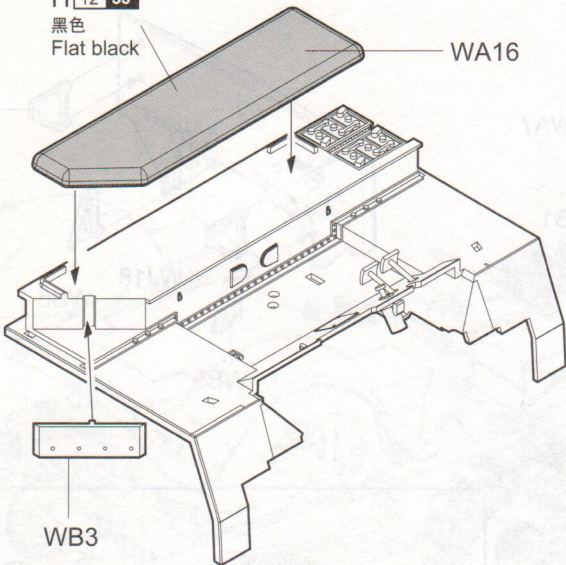

WB3

WI13

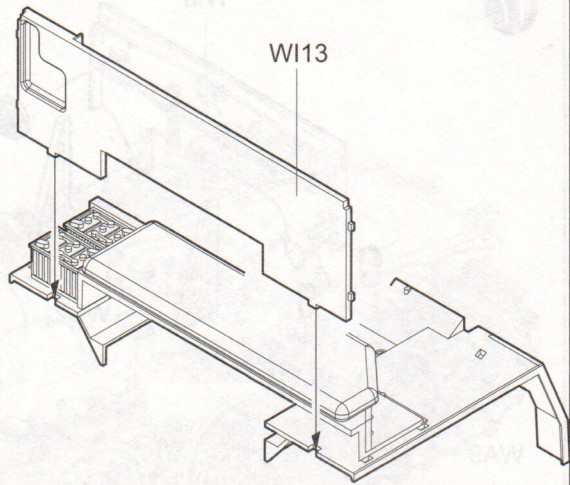

H 12 33

黑色
Flat black

WA3

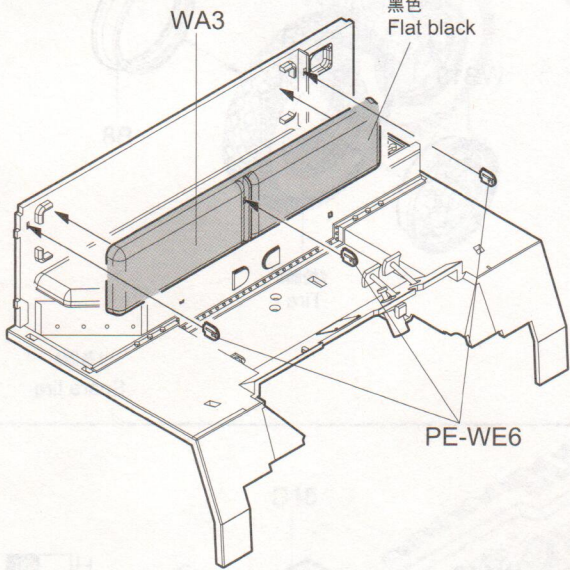

PE-WE6

WI20

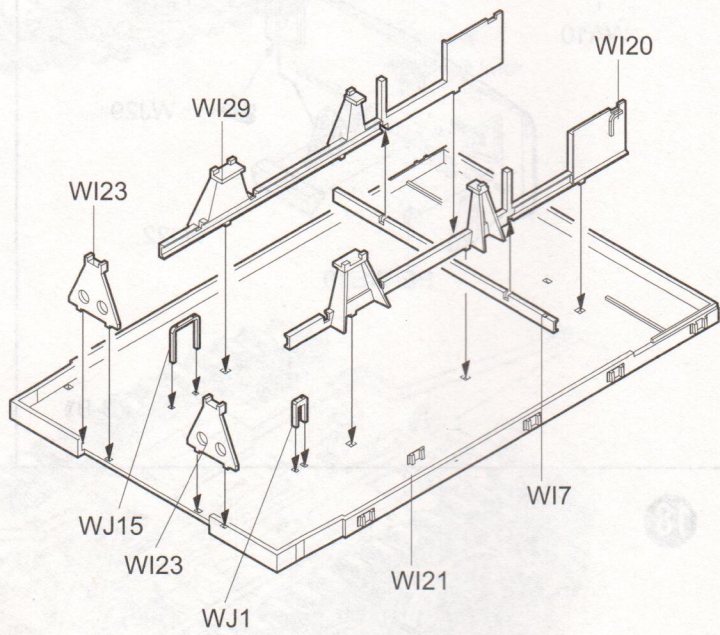

WI29

WI23

WJ15

WI23

WJ1

WI21

WI7

WI16

WI6

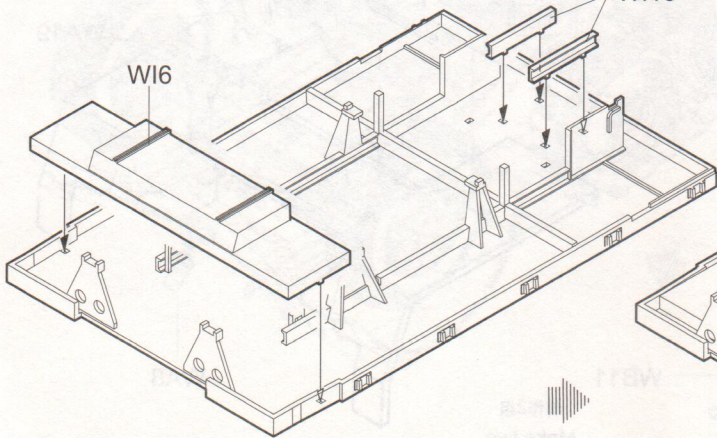

WI30

WI17

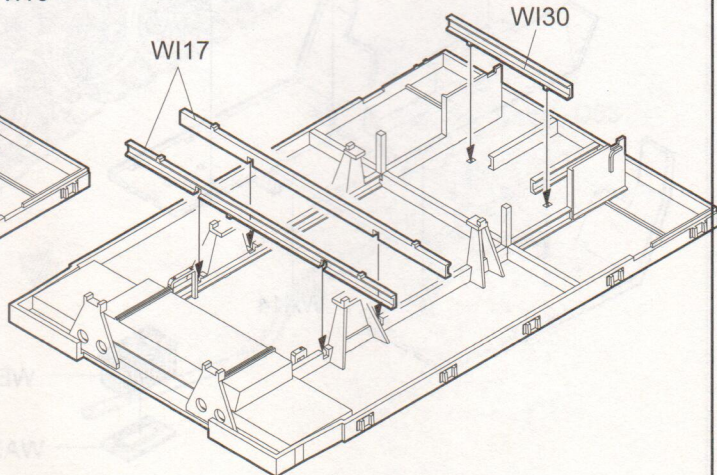

20

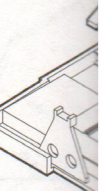

21

20

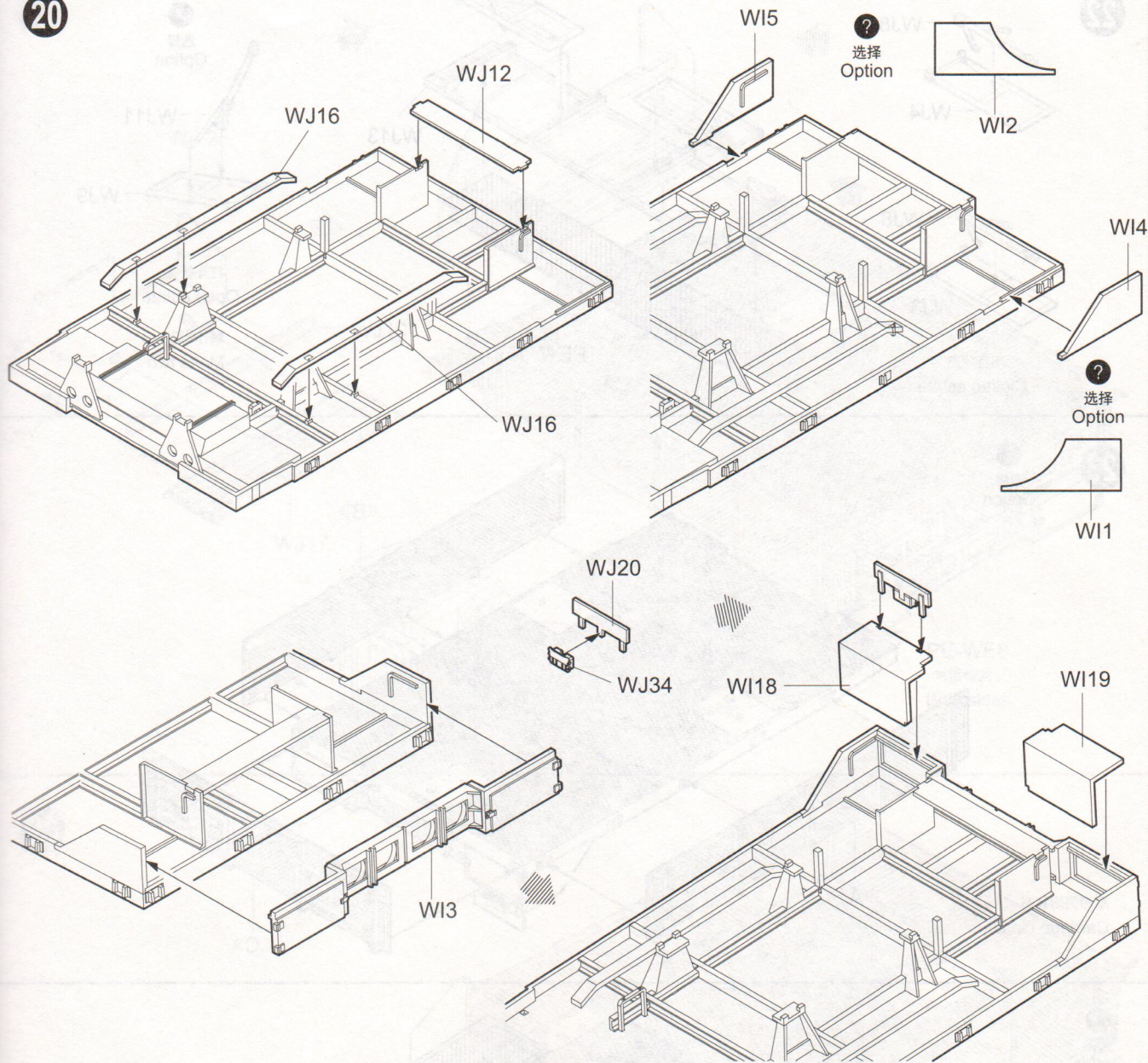

21

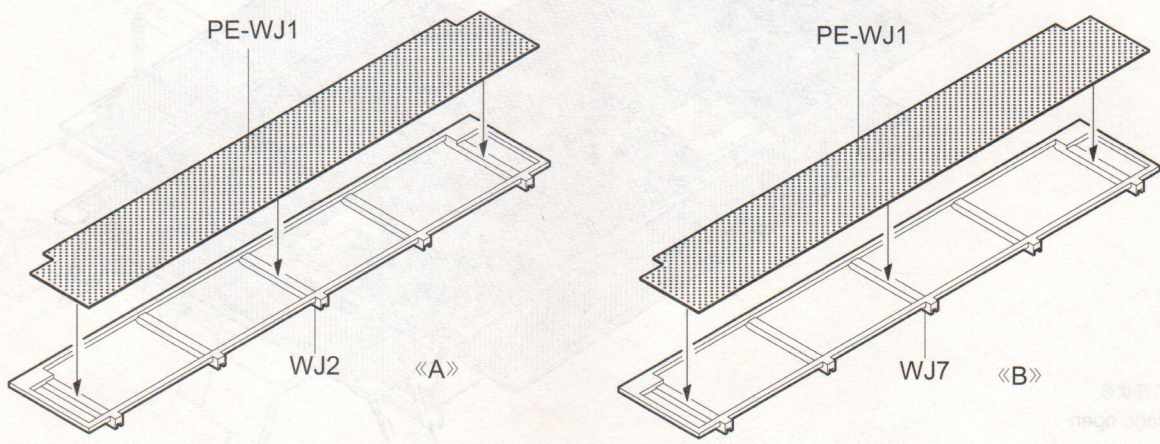

22

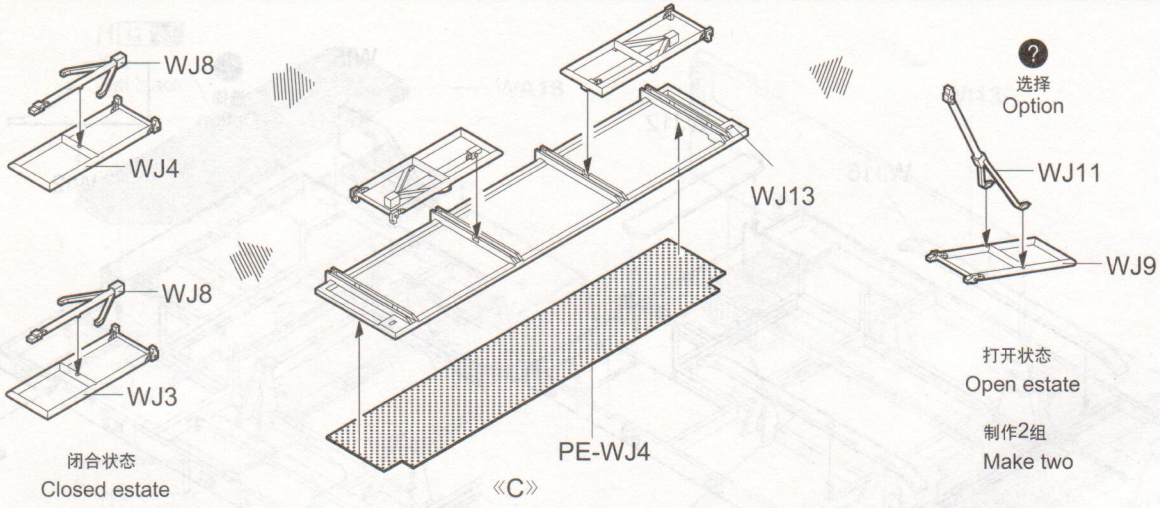

23

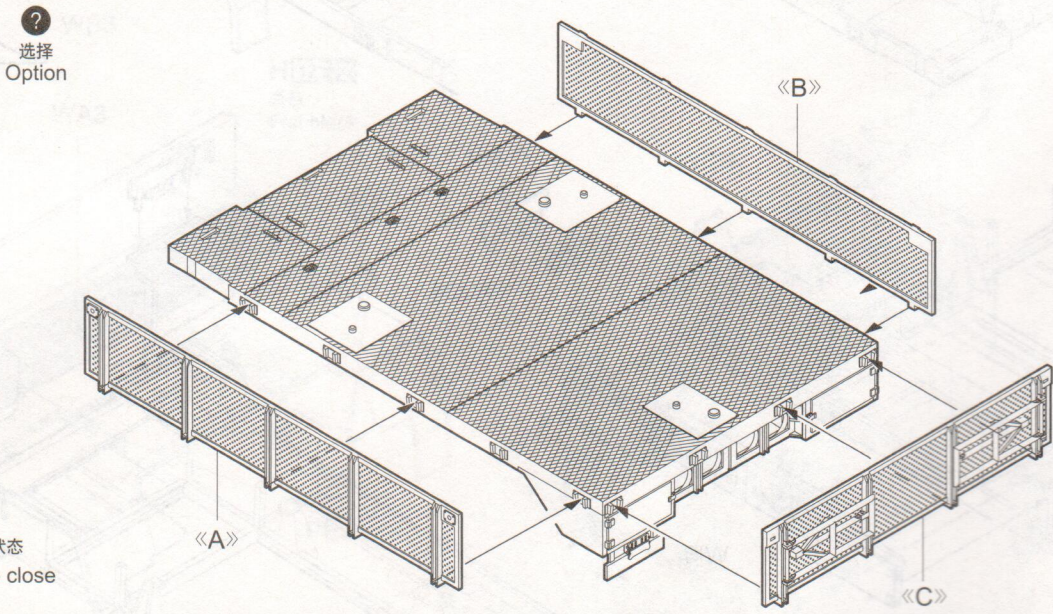

?

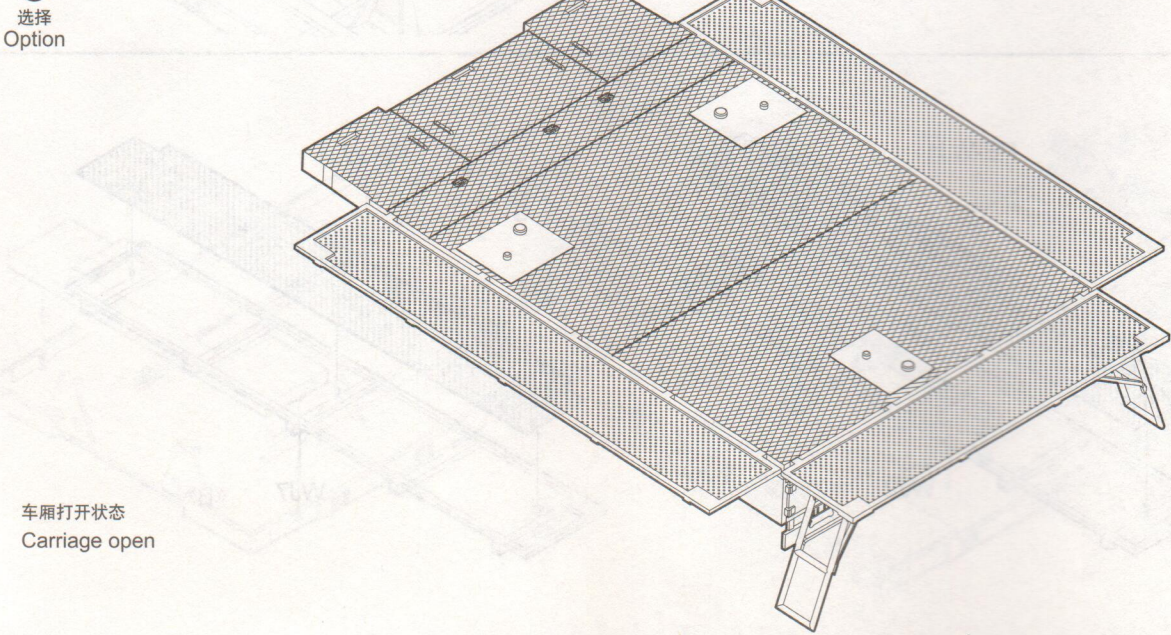

24



25



24

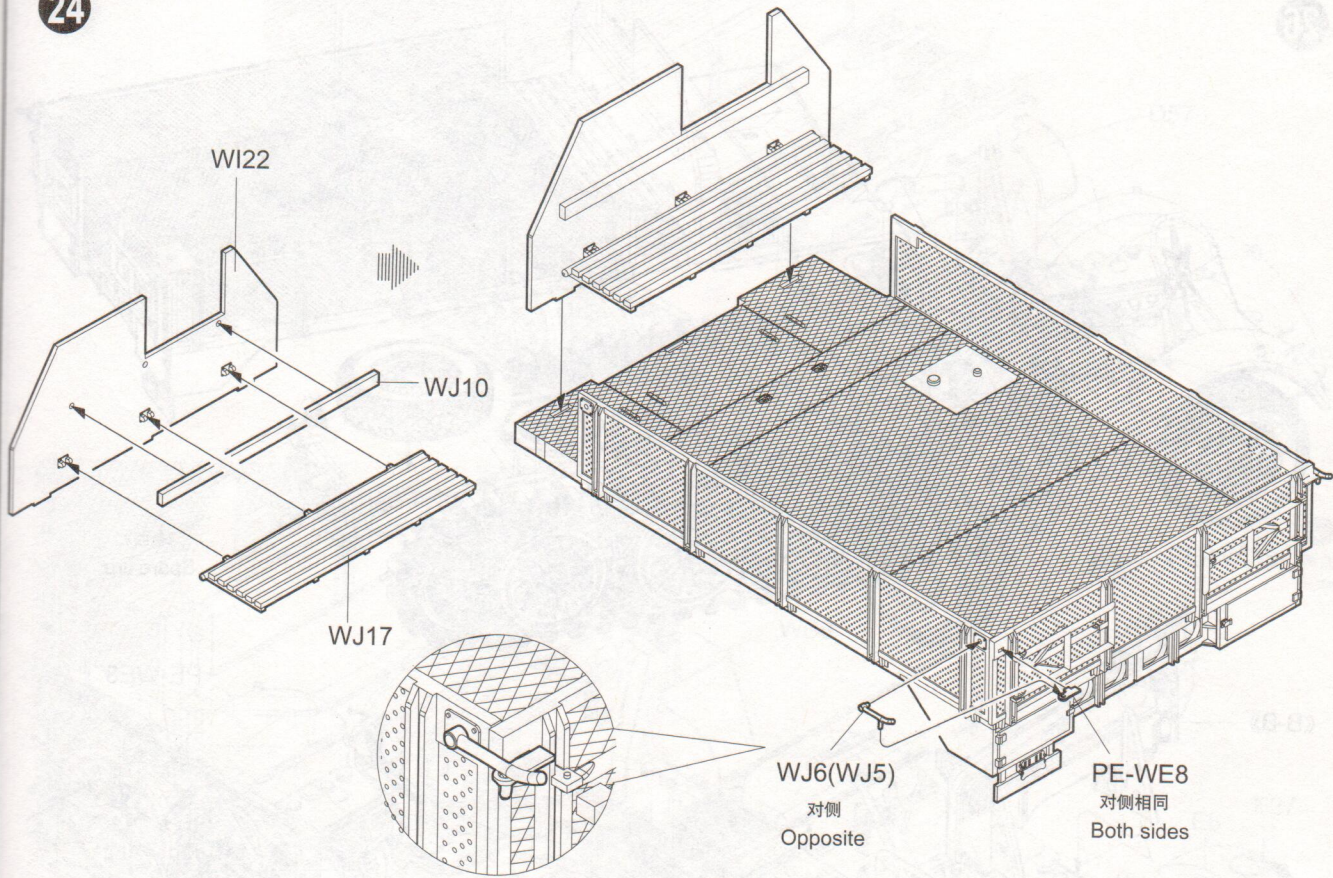

25

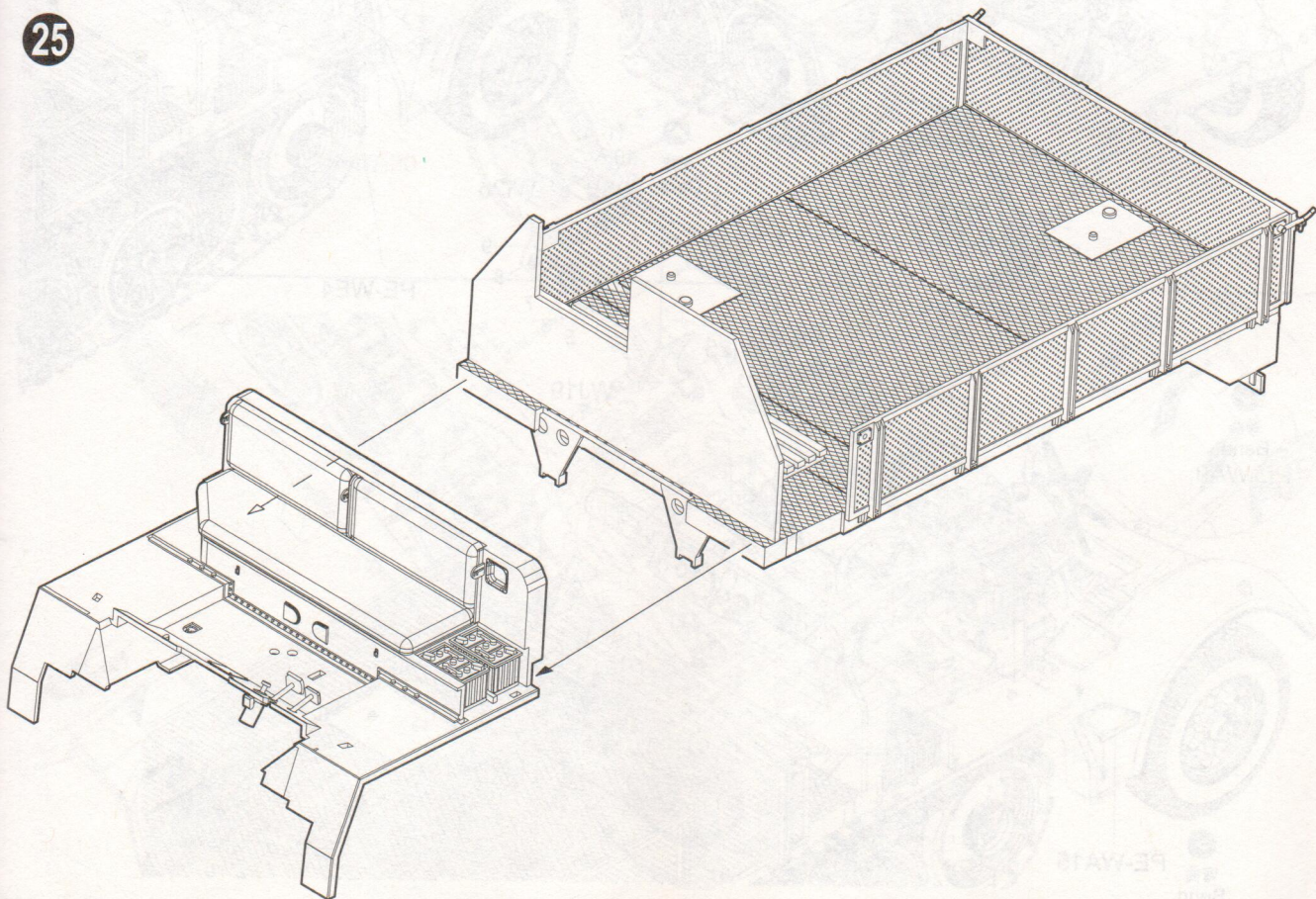

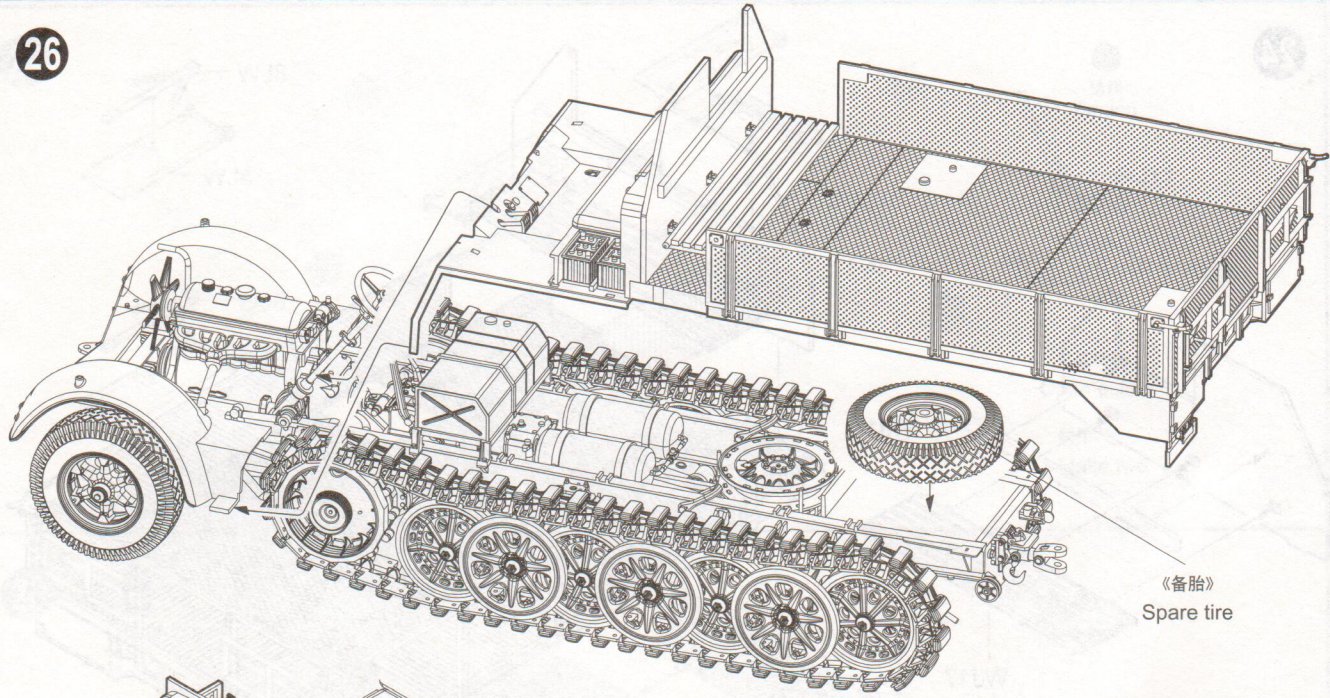

《B-B》

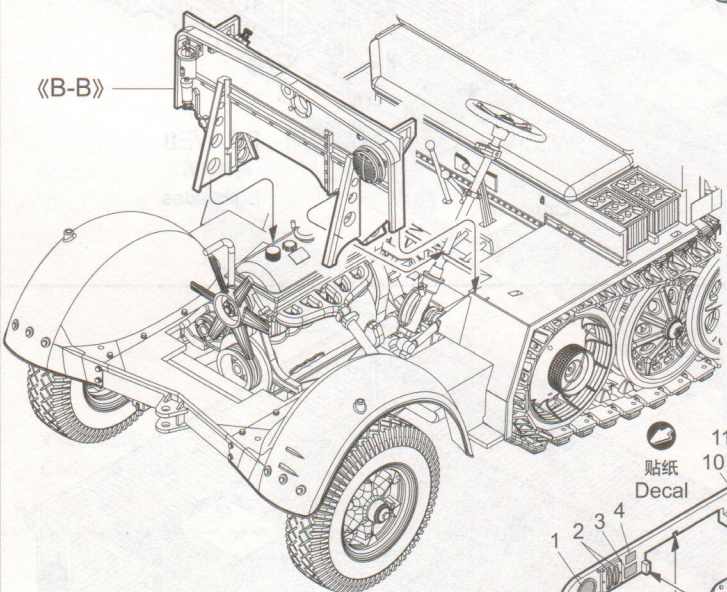

PE-WE3

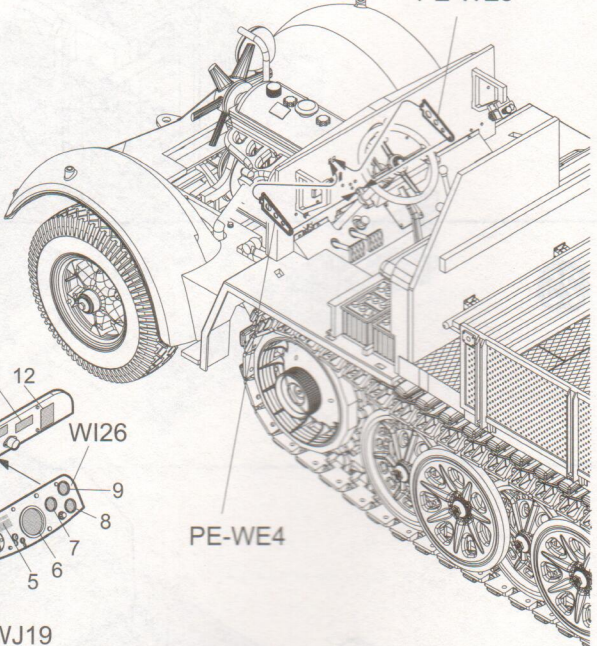

PE-WE4

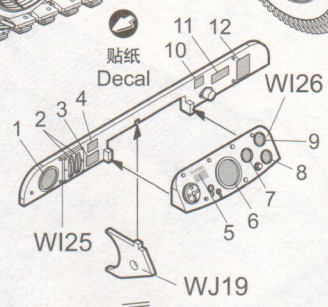

弯曲
Bend
PE-WA9

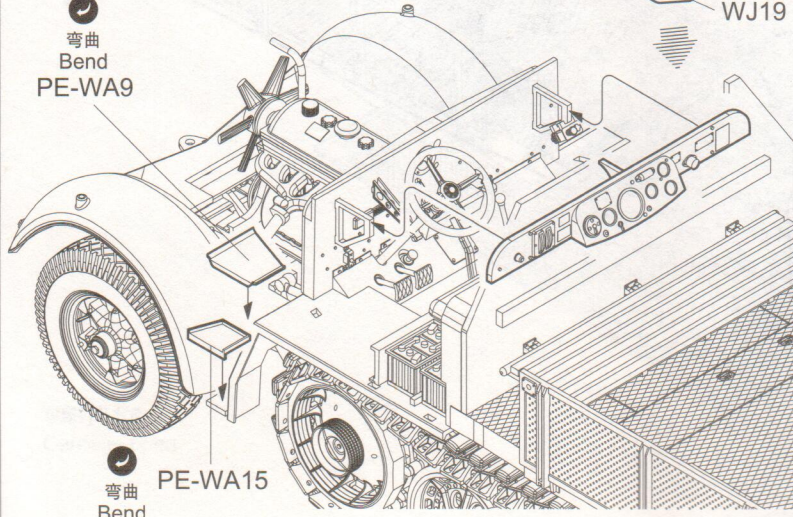

弯曲
Bend
PE-WA15

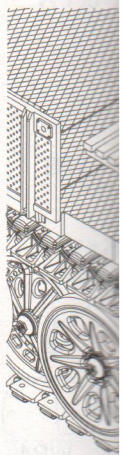
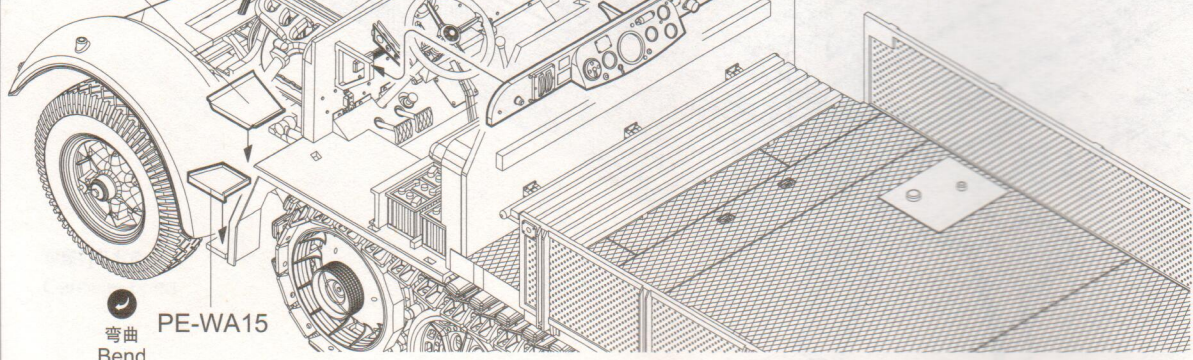

弯曲
Bend

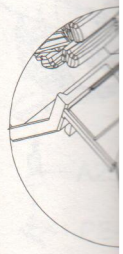

27

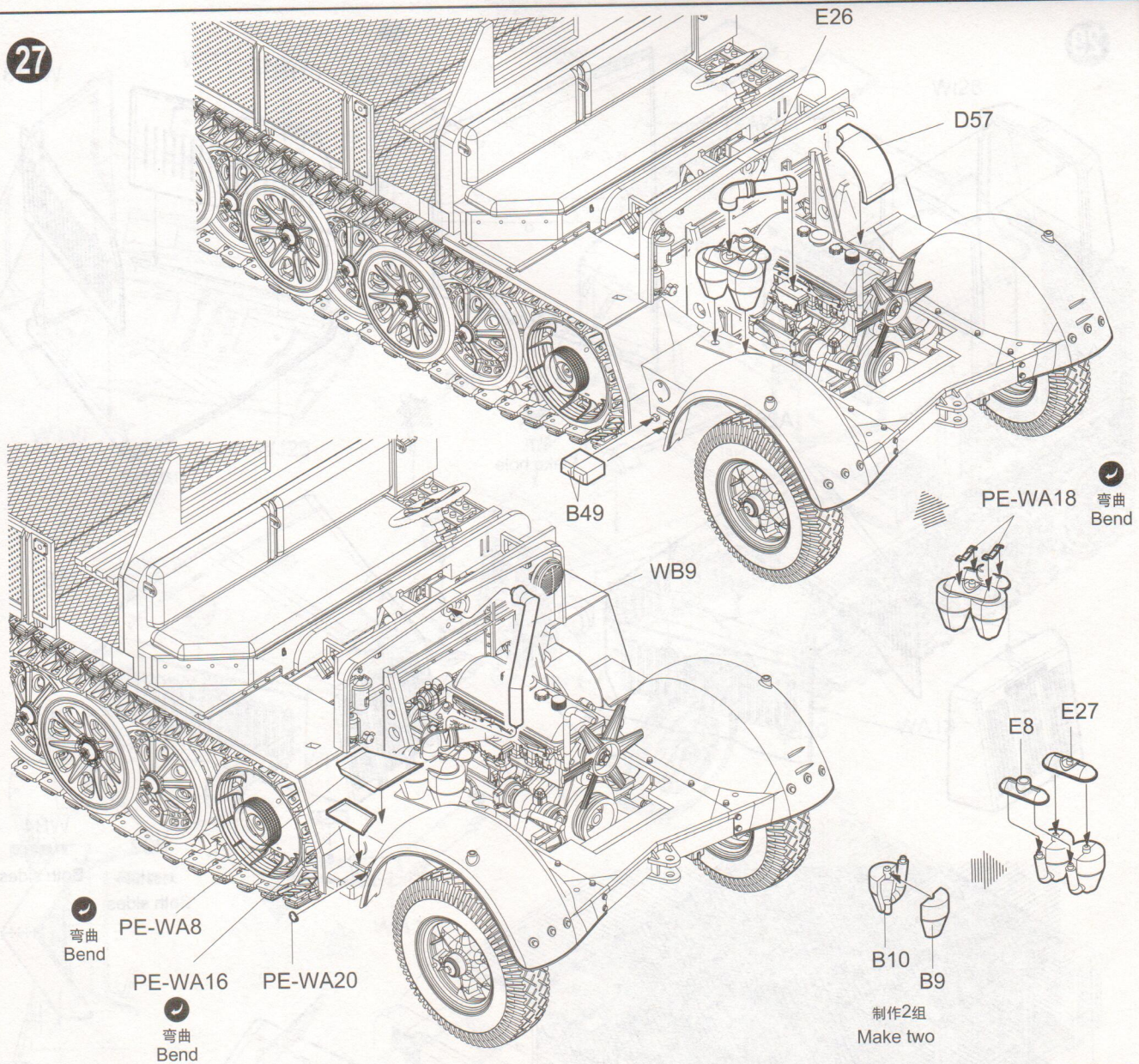

28

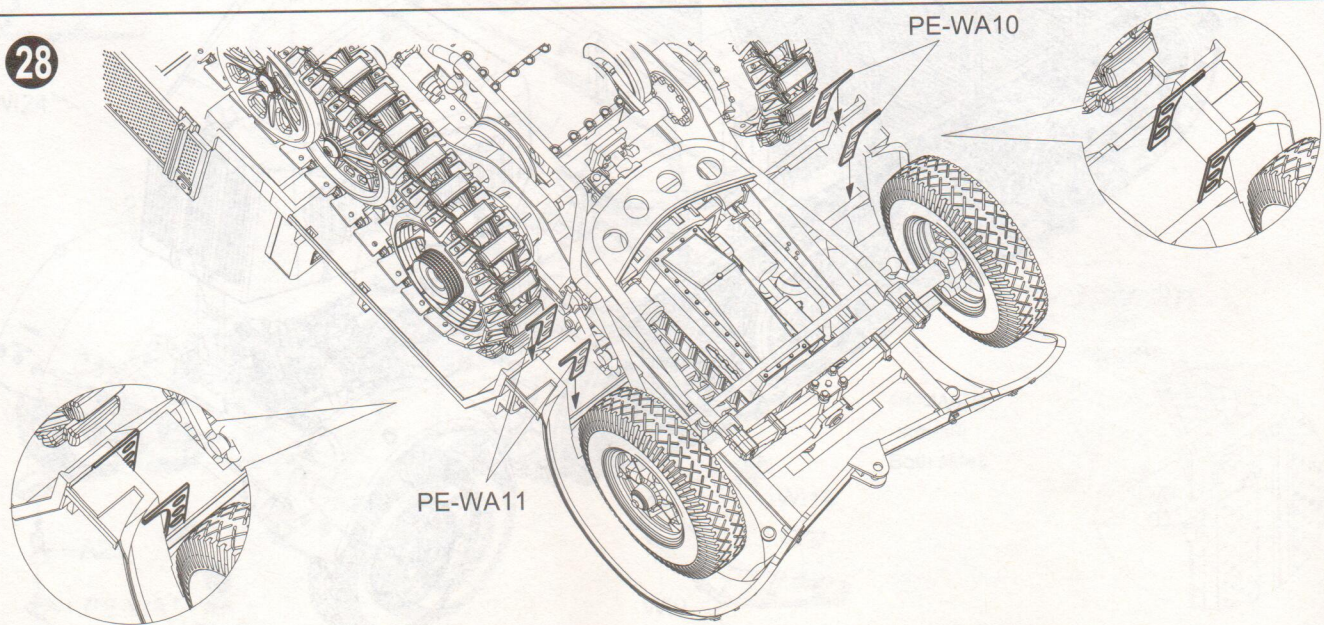

29

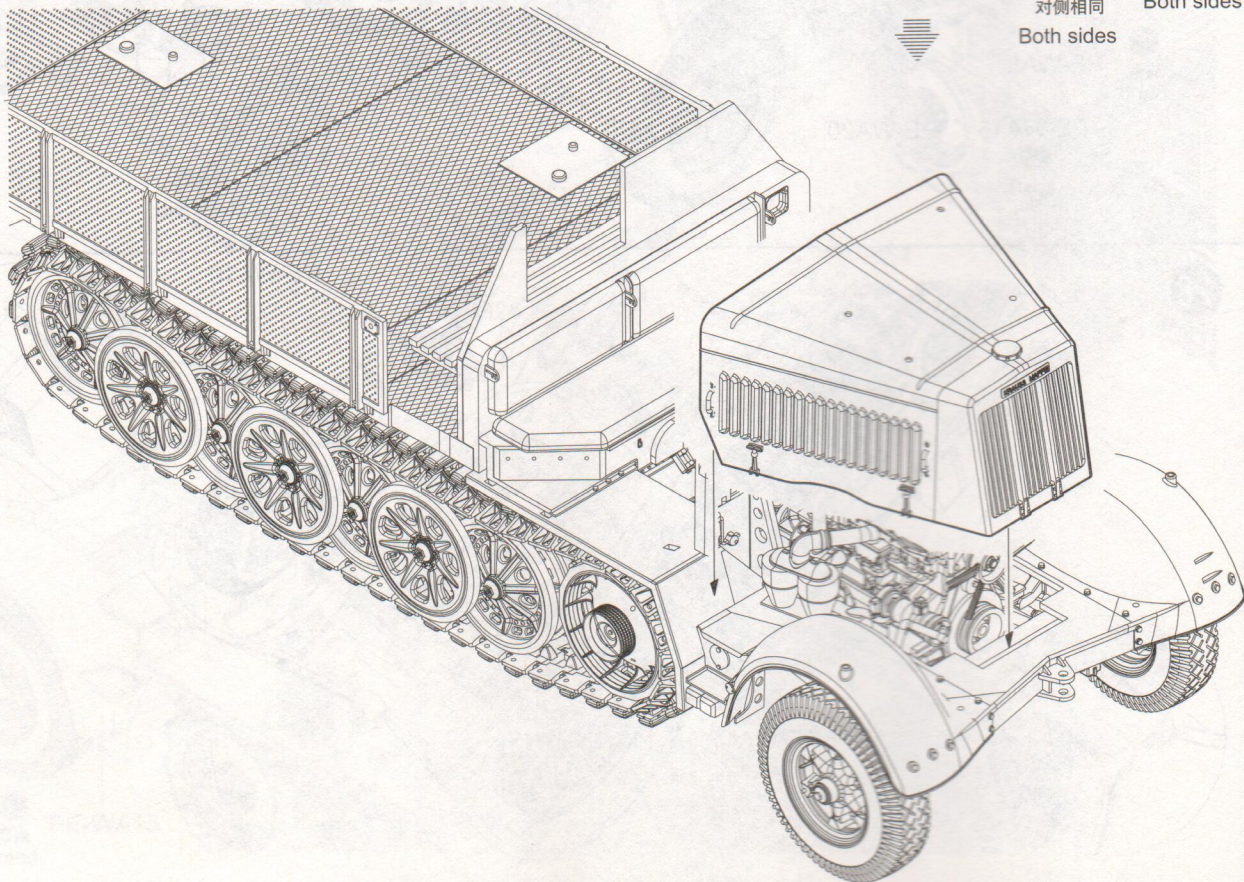
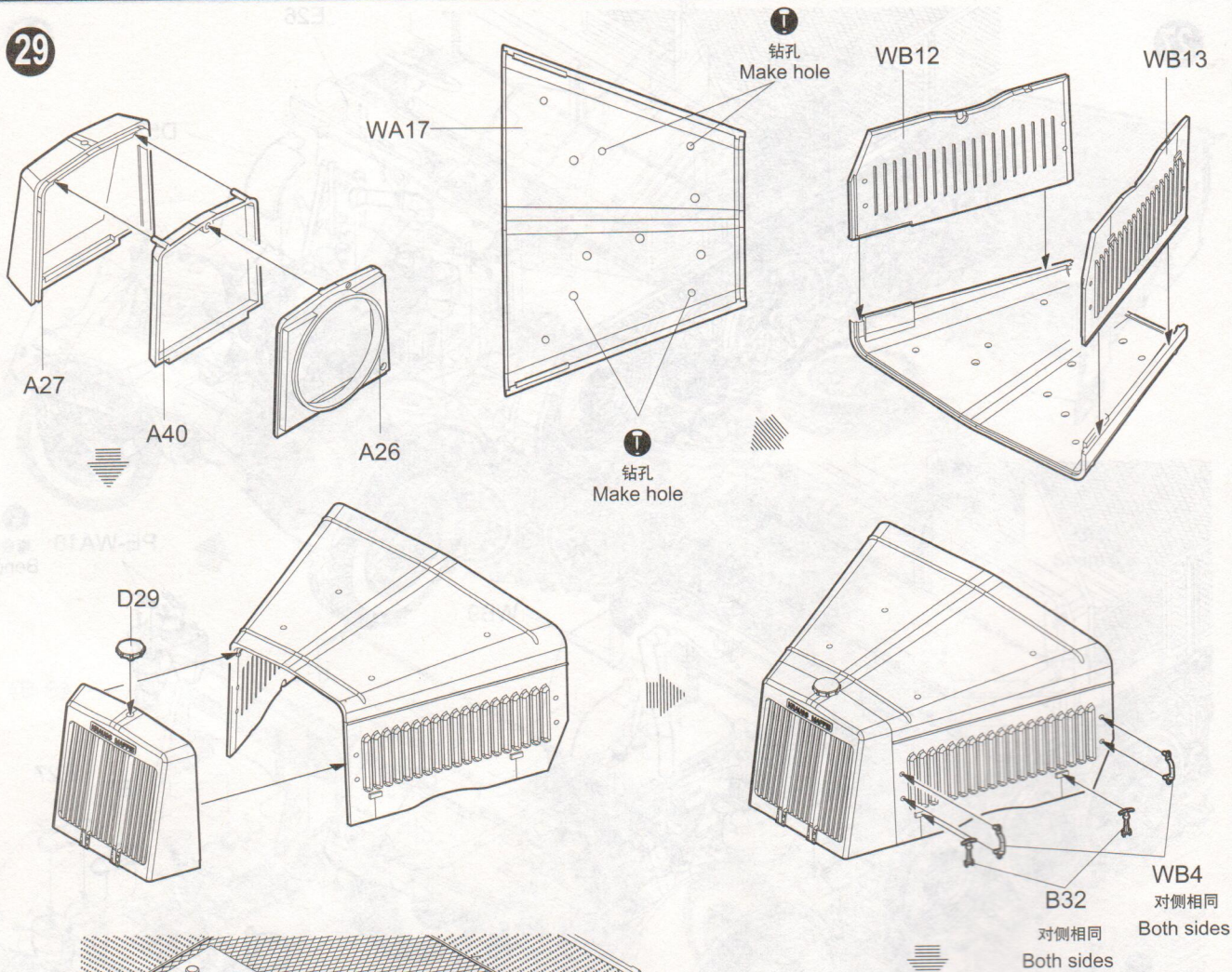

30

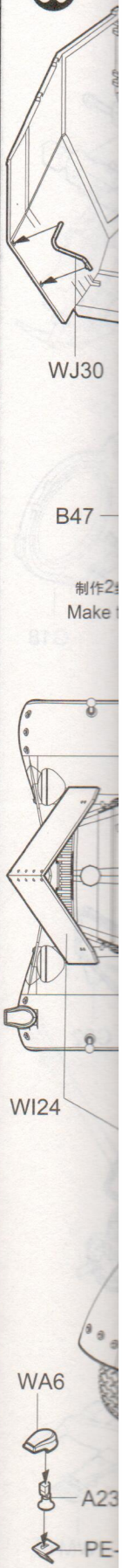

30

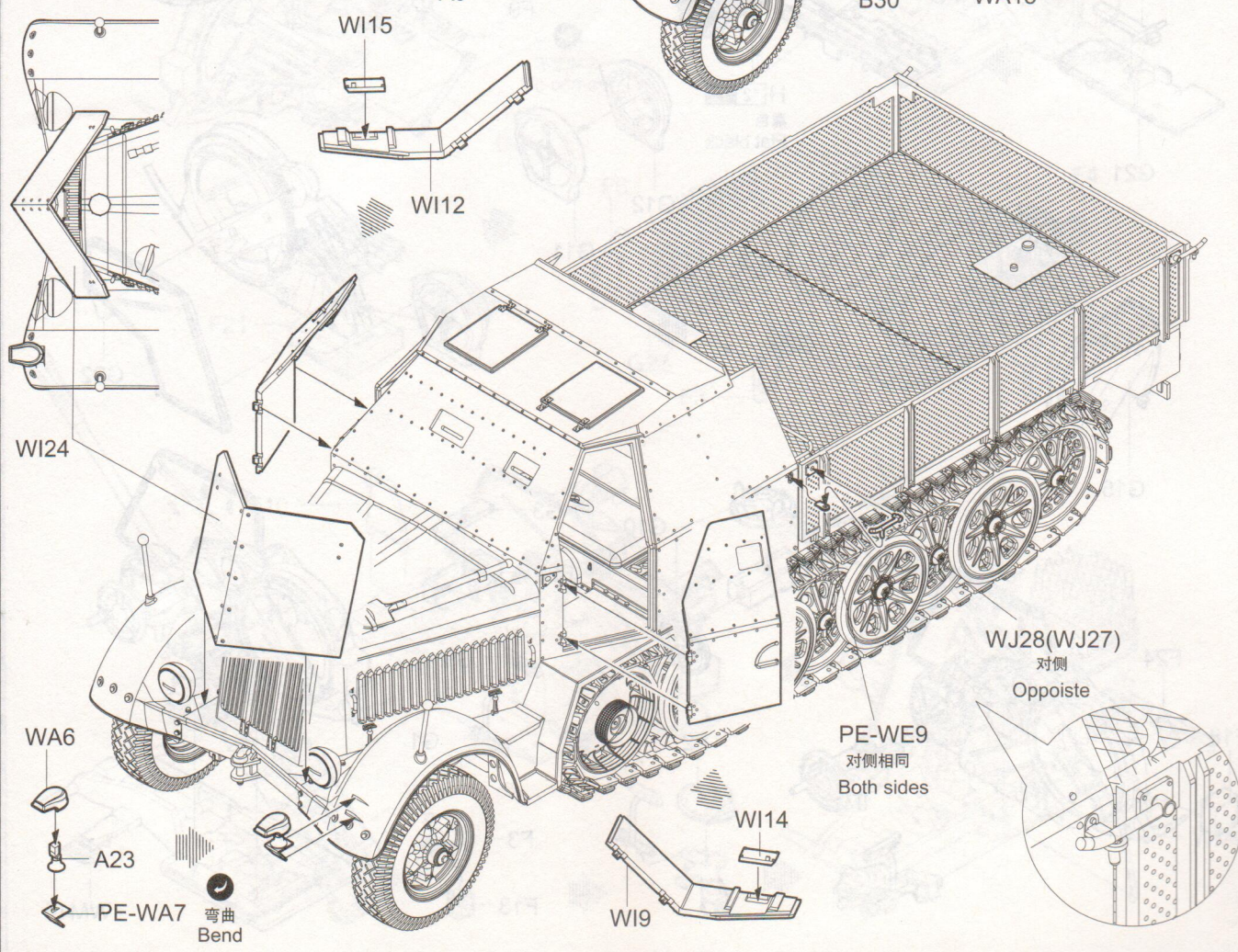
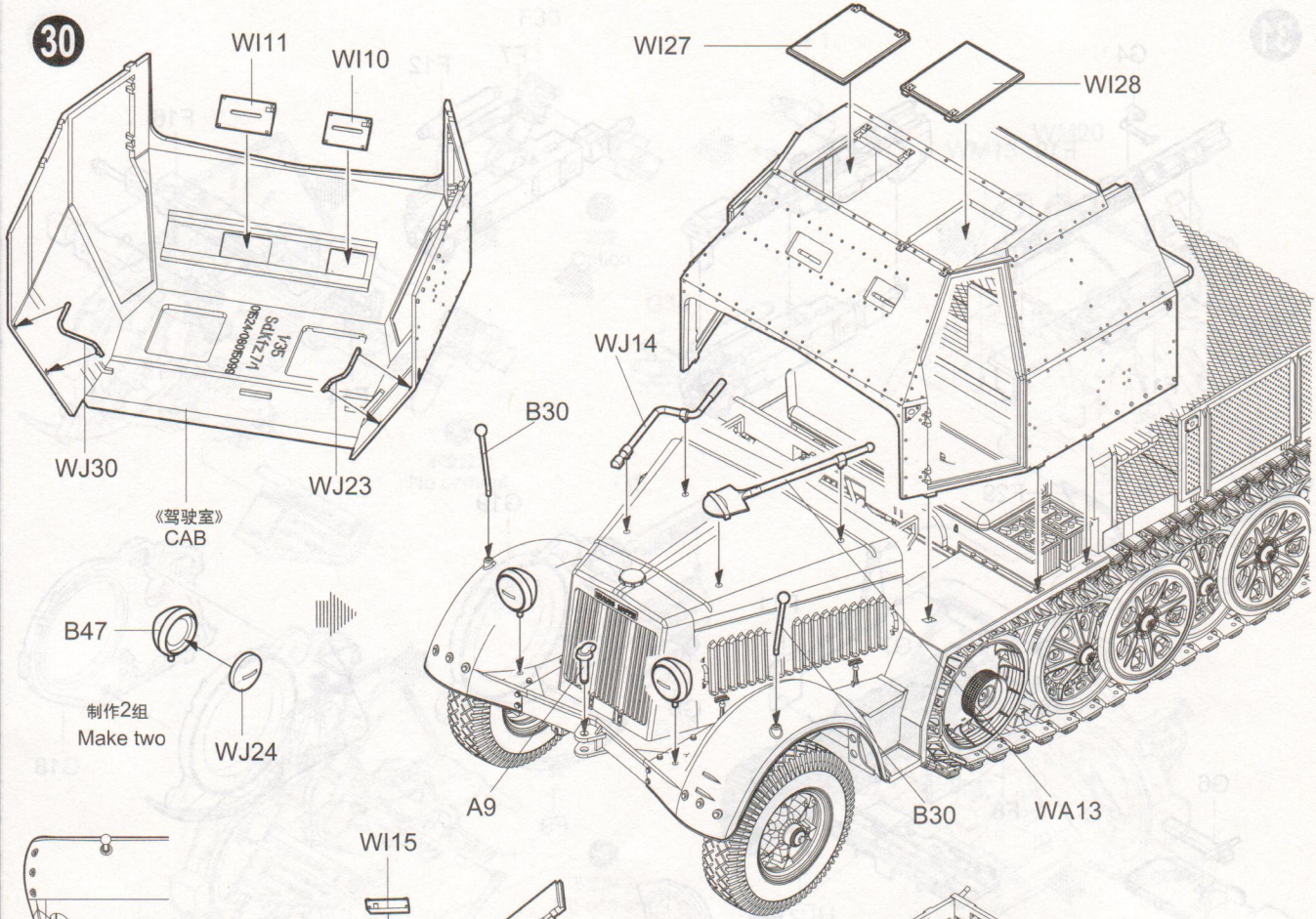

31

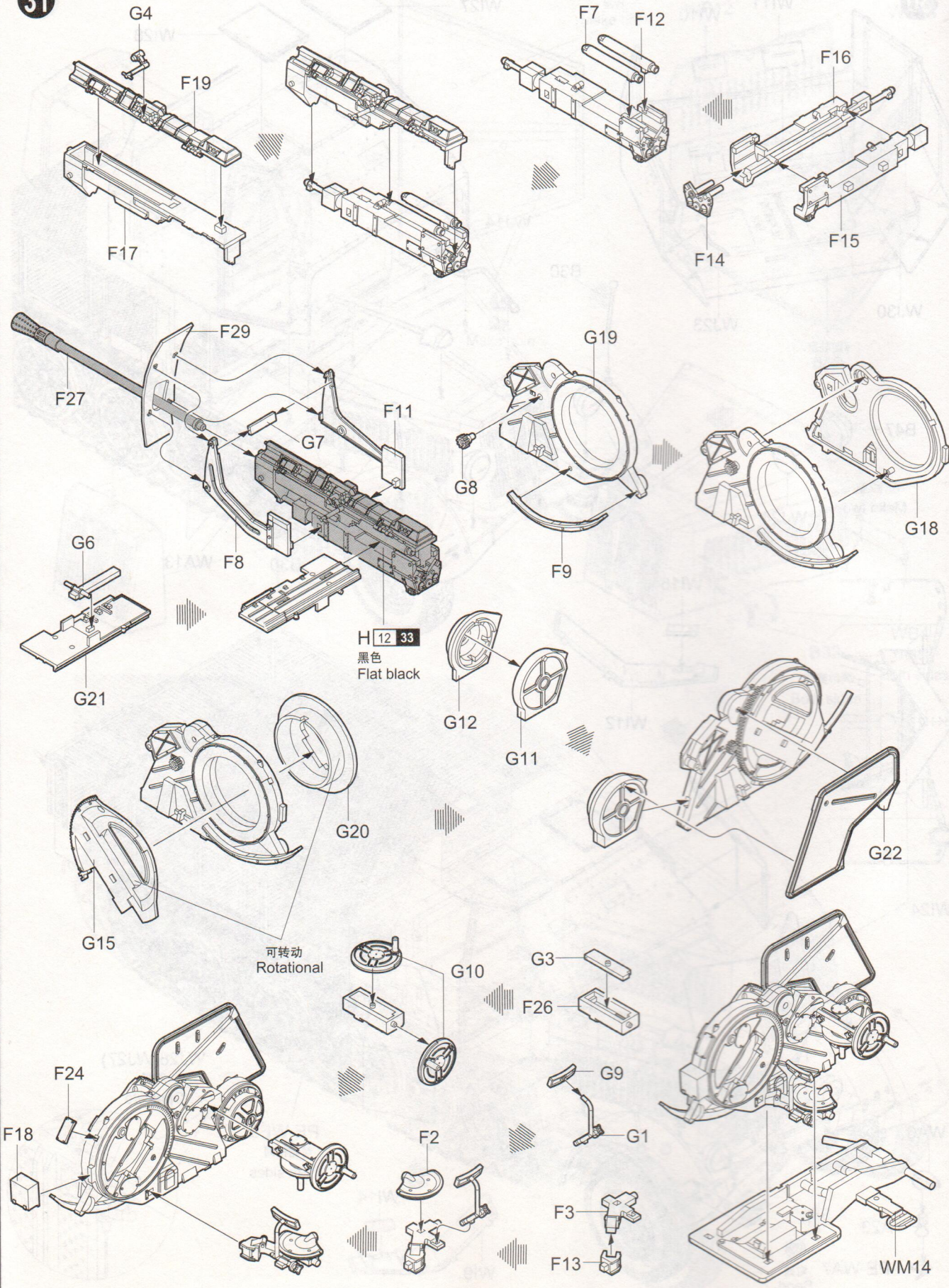

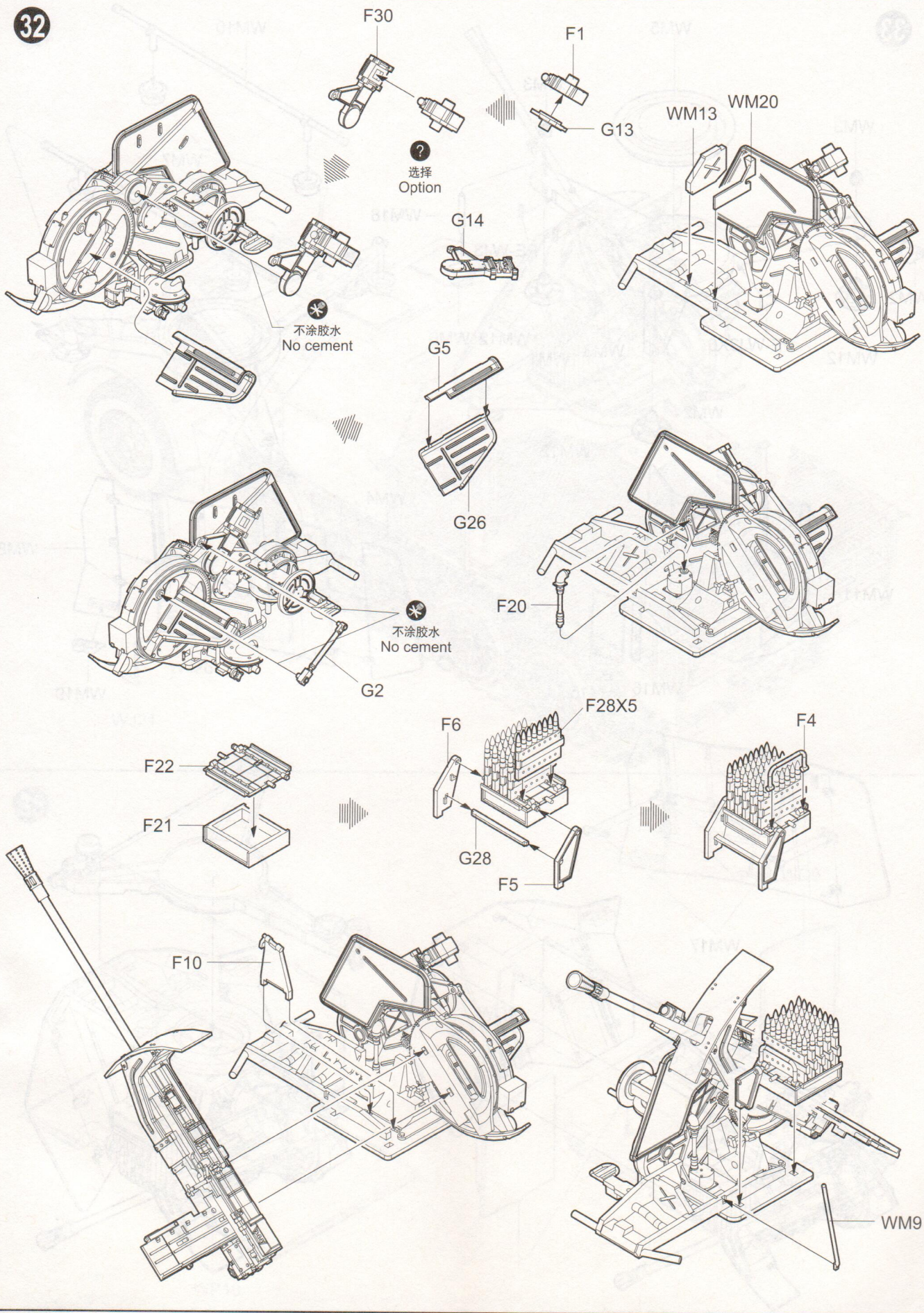

33

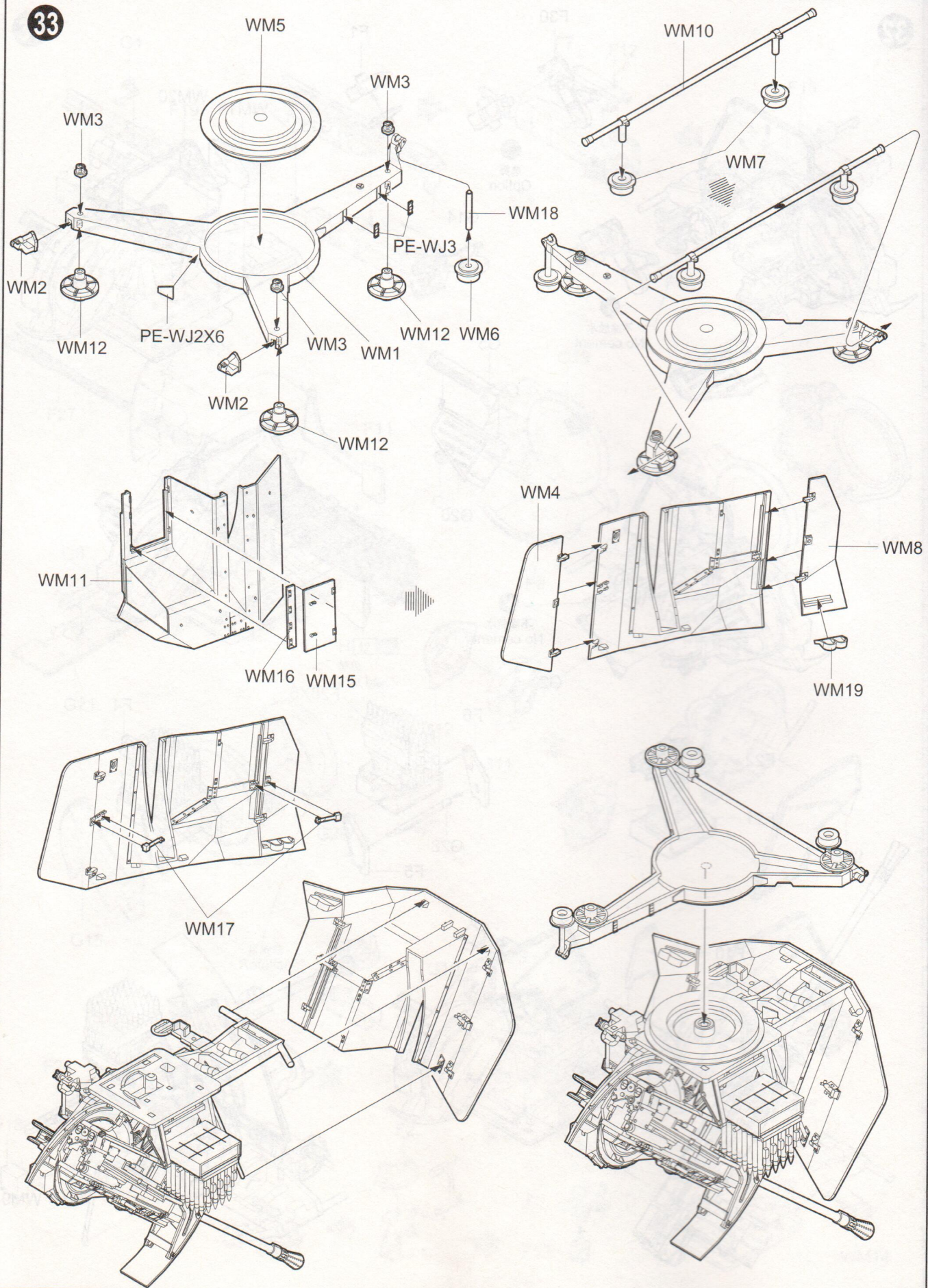

34

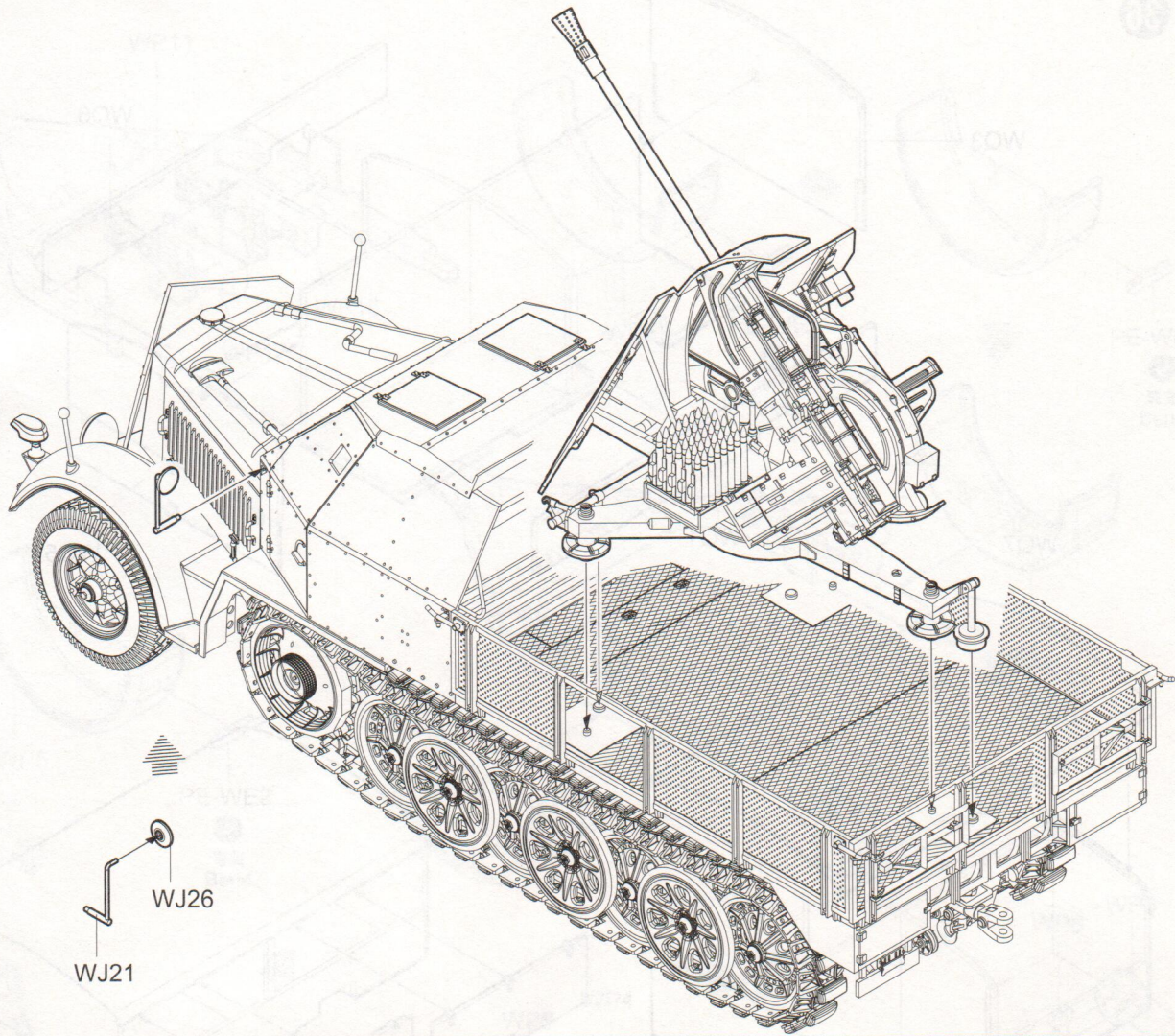

35

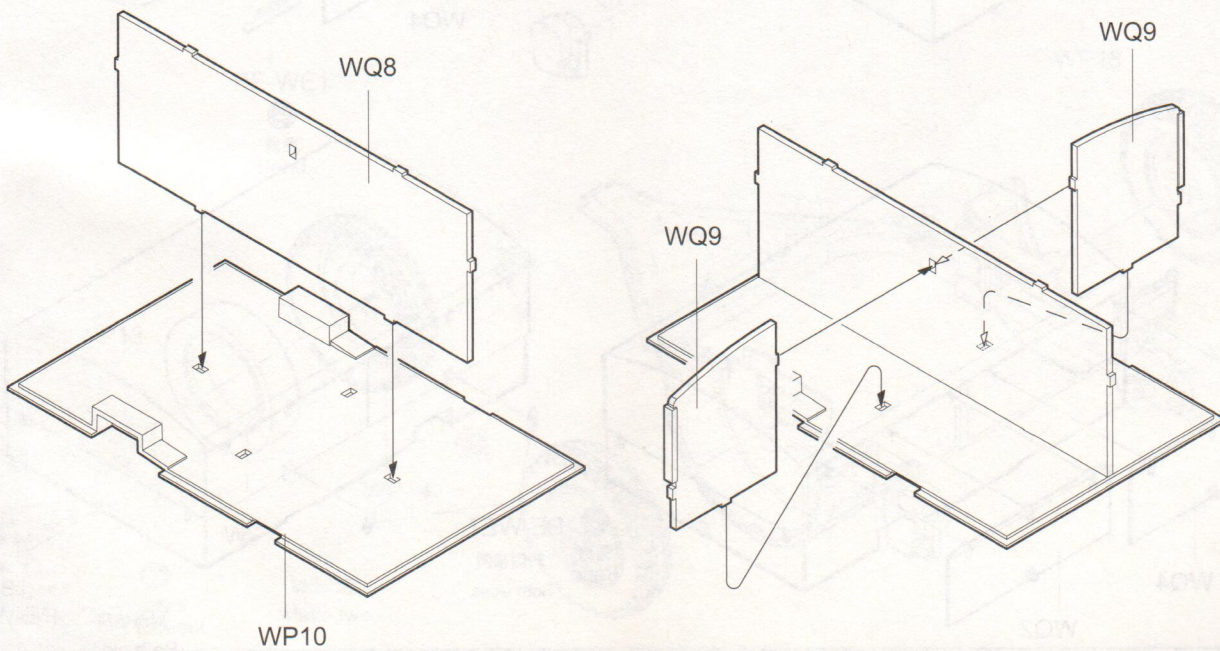

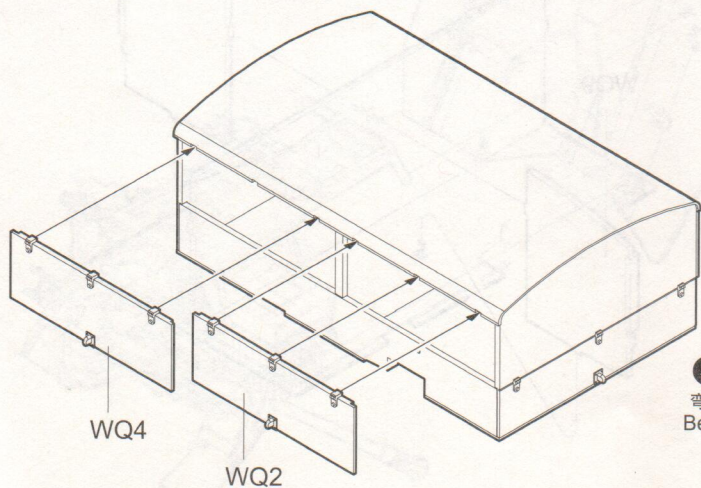
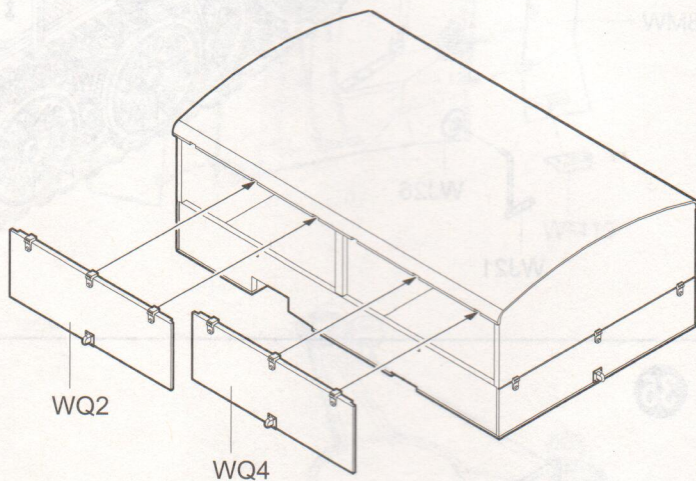
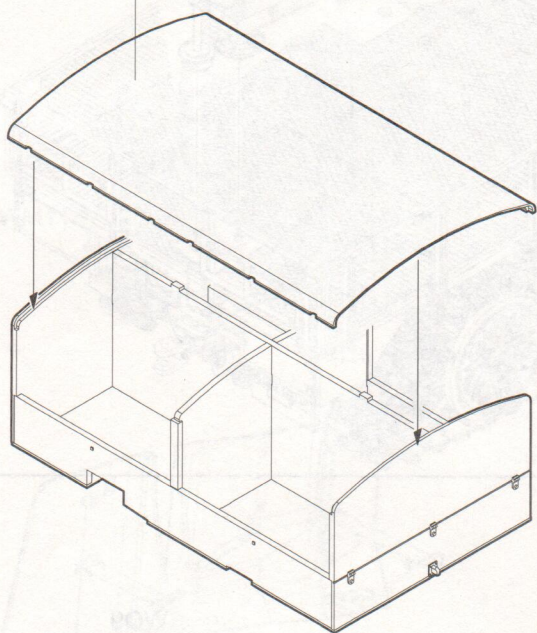
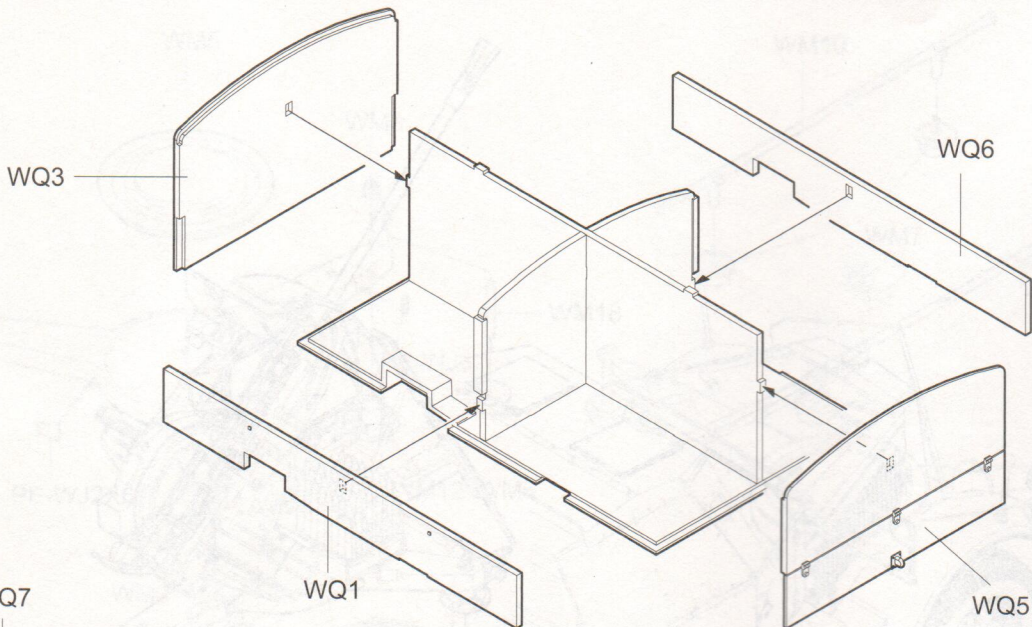

PE-WE7
 弯曲
 Bend
 对侧相同
 Both sides

PE-WE5
 弯曲
 Bend
 对侧相同
 Both sides

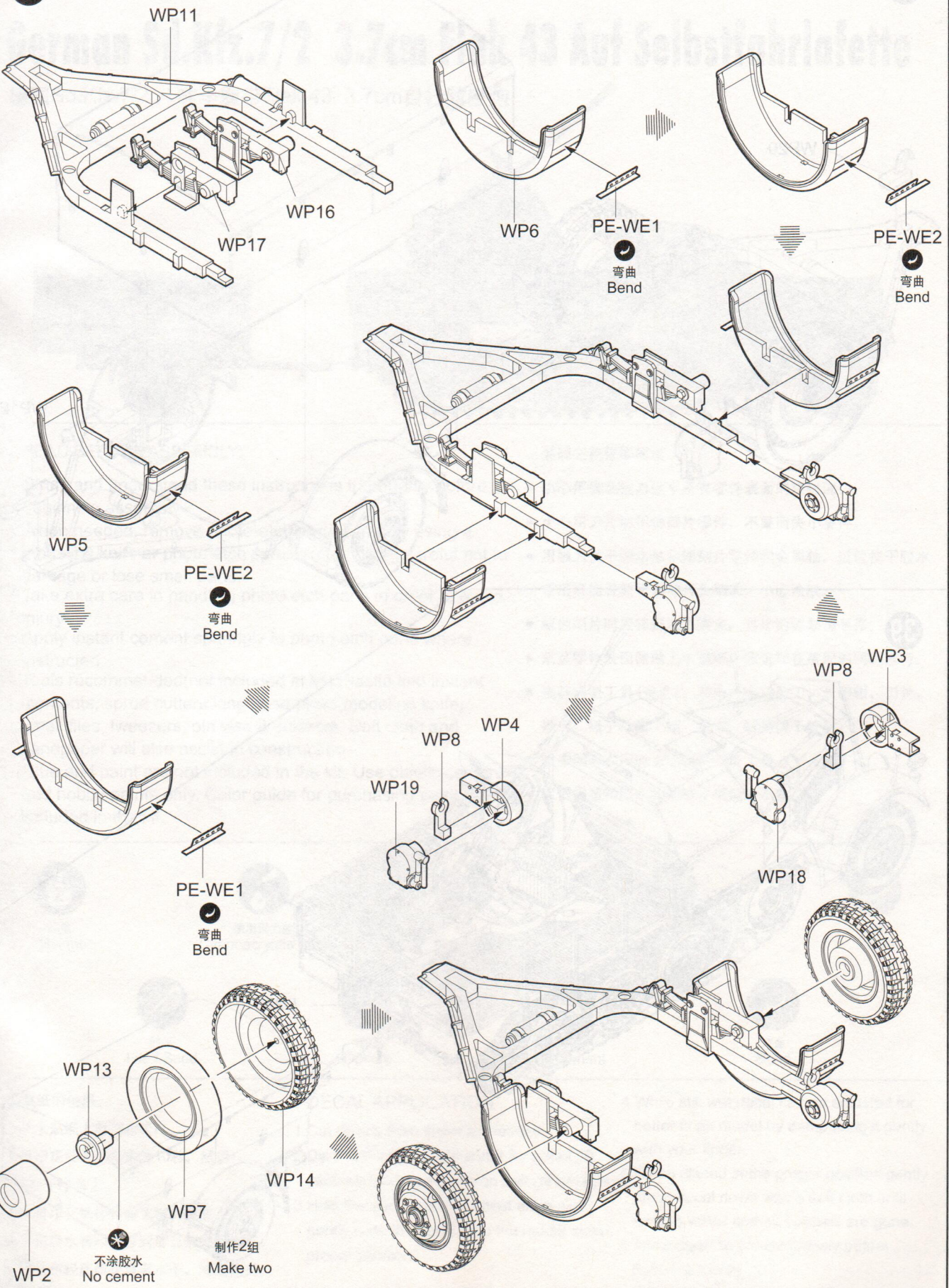

38

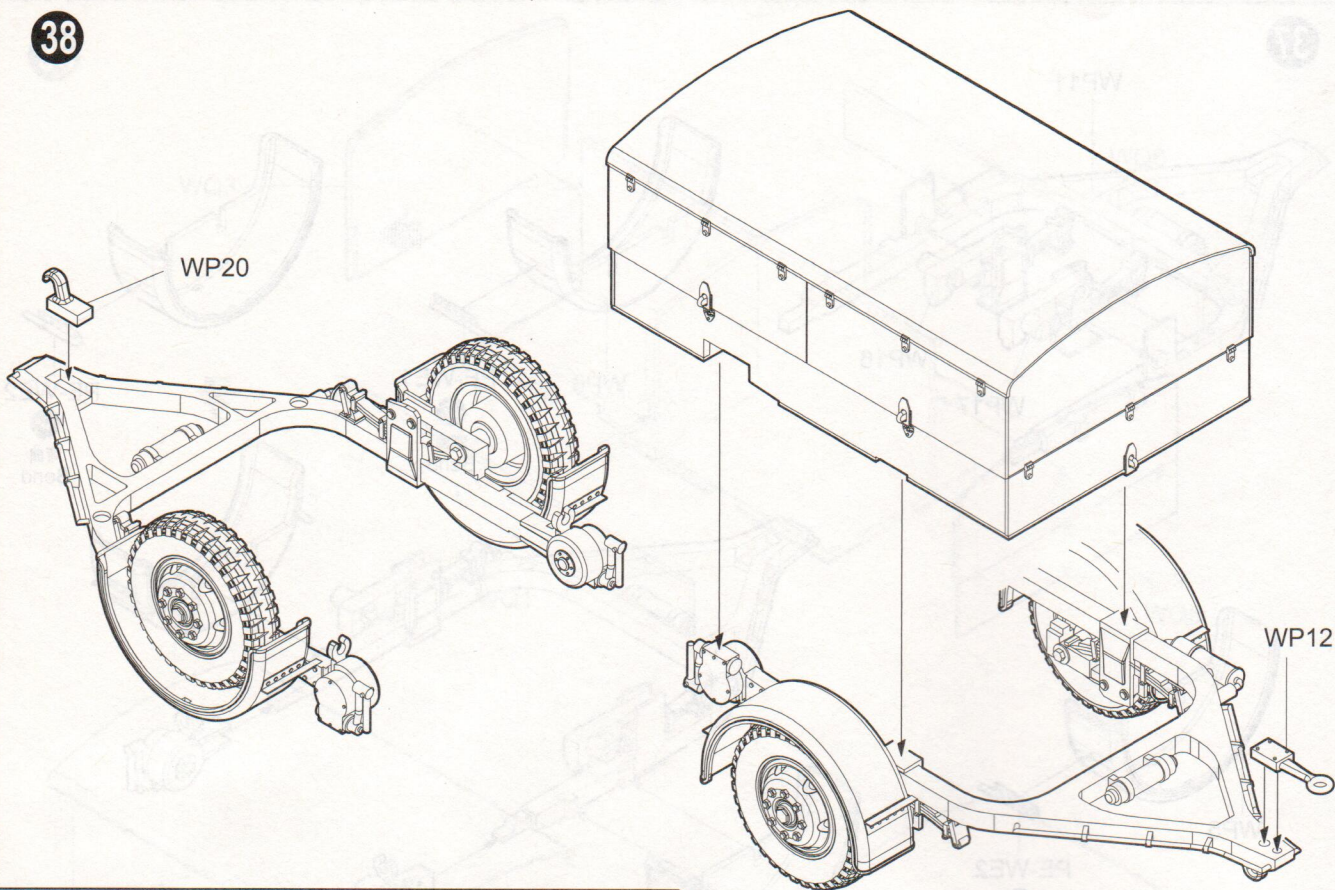

39

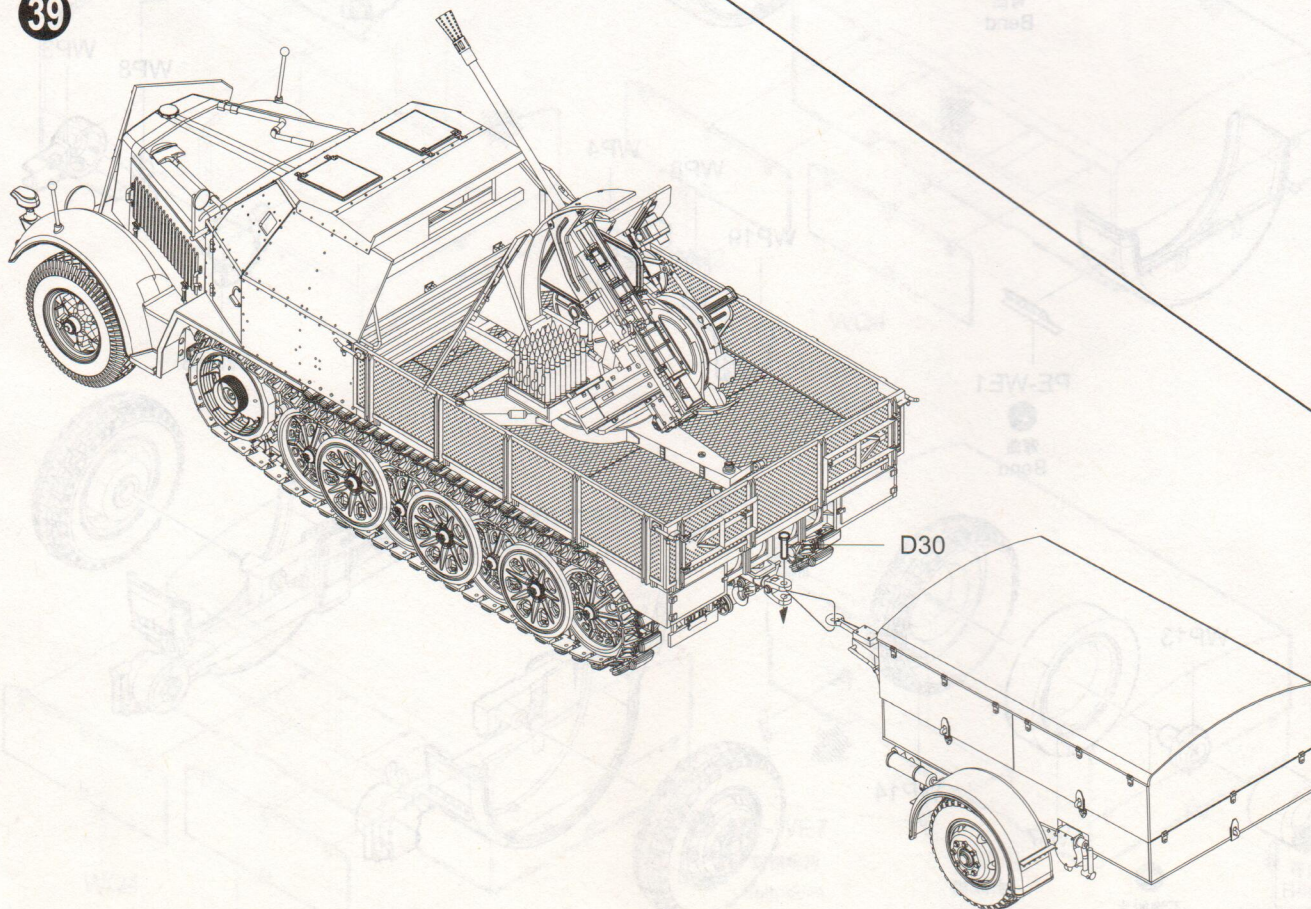

涂装同标贴指示
Painting & Marking guide

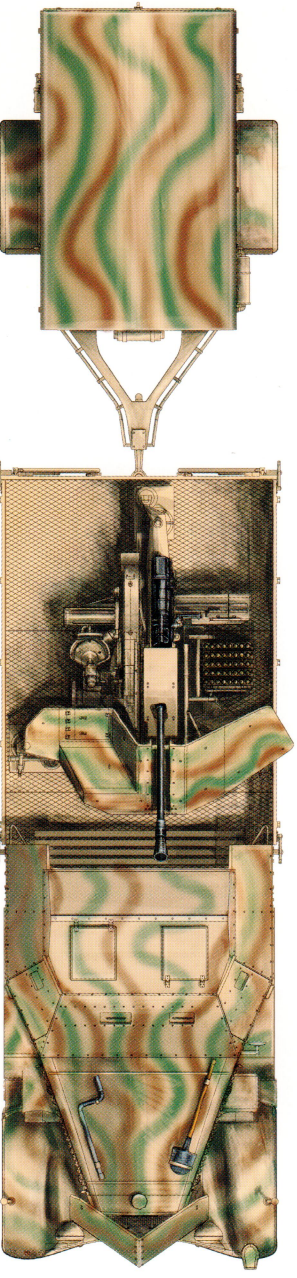

PA	
C	
T	
Da	
Slie	
Rd	
Dd	

H X AQUEOUS HOBBY COLOUR

X MR COLOUR

01527 1/35 German Sd.Kfz. 7/2 3.7cm Flak 43 Auf Selbstfahrlafette