



# 1:48 Curtiss P-40B Warhawk

A05130A SCALE MODEL CONSTRUCTION KIT | Wingspan: 237mm Fuselage Length: 202mm | Two Decal Schemes Included

EN

The P-40B, in its various incarnations, served the United States Army Air Force throughout the Second World War, fighting in Europe, across Asia and in the deserts of North Africa. The first model to see active service, the P-40B proved to be an effective and tough low level fighter. While not as manoeuvrable as the Japanese Mitsubishi Zero, or as fast as the German Messerschmitt Bf109, the P-40B still proved to be a tough opponent. Pilots liked the fact it could often get them home after sustaining heavy damage, as well as being able to inflict it with its armament of six machine guns. The P-40B became synonymous with the shark mouth motif, due to both its use with 112 Squadron and the American Volunteer Group in China. Today the P-40B continues to fly in the United Kingdom as well as its homeland of the United States of America.

### Specification

Maximum Speed: 350 mph (560km/h)

Range: 730 miles (1,200 km) with maximum fuel

Wingspan: 37 ft 4 in (11.38m)

Length: 31 ft 8.0 in (9.66m)

Armament: 4 x .30cal Browning machine guns, 2 x .50cal Browning machine guns

FR

Les différentes versions du P-40B opèrent au sein de la USAAF (force aérienne de l'armée des États-Unis) pendant toute la Deuxième Guerre mondiale, prenant part aux combats en Europe, partout en Asie et au-dessus des déserts de l'Afrique du Nord. Le premier modèle opérationnel, le P-40B s'avéra être un chasseur à basse altitude performant et robuste. Même si moins manoeuvrable que le Mitsubishi Zero japonais et moins rapide que le Messerschmitt Bf109 allemand, le P-40B avec ses six mitrailleuses était un adversaire formidable et très apprécié par ses pilotes grâce à sa capacité de les retourner à leur base même après avoir subi des dégâts lourds. Utilisé par l'escadron 112 et par le groupe de volontaires américains (les Tigres volants) en Chine, l'avion devint célèbre avec son motif de gueule de requin. De nos jours, le P-40B vole toujours au Royaume-Uni ainsi qu'aux États-Unis, son pays d'origine.

### Spécification:

Vitesse maximale: 560 km/h

Autonomie: 1.200 km avec carburant maximum

Envergure: 11.38 m

Longueur: 9.66 m

Armement: 4 mitrailleuses Browning de 7,6 mm et 2 mitrailleuses Browning de 12,7 mm

DE

Die P-40B diente der US Army Air Force in verschiedenen Versionen im gesamten Verlauf des Zweiten Weltkriegs und war an Kampfhandlungen in Europa, in weiten Teilen von Asien und im nordafrikanischen Wüstenkrieg beteiligt. Die erste aktiv eingesetzte Version P-40B bewährte sich besonders als effektives Jagdflugzeug bei Tiefflügen. Zwar nicht so wendig wie die japanische Mitsubishi Zero oder so schnell wie die deutsche Messerschmitt Bf109, erwies sich die P-40B dennoch als schlagkräftiger Gegner. Viele Piloten schätzten ihre Fähigkeit, auch nach schwerer Schadenaufnahme für den Heimflug tauglich zu sein; mit ihrer aus sechs MG bestehenden Bewaffnung konnte sie feindlichen Flugzeugen empfindlichen Schaden zufügen. Die P-40B wurde weitgehend mit ihrem Haimaulmotiv identifiziert, das auf den Maschinen aufgemalt war, die vom Geschwader Nummer 112 und vom Freiwilligenverband „American Volunteer Group“ in China verwendet wurden. Die P-40B wird auch heute noch in Großbritannien wie auch in ihrem amerikanischen Heimatland geflogen.

### Spezifikation:

Höchstgeschwindigkeit: 560 km/h

Reichweite: 1.200 km mit maximaler Treibstoffzuladung

Spannweite: 11.38 m

Länge: 9.66 m

Bewaffnung: 4 Browning MG 7,6 mm, 2 Browning MG 12,7 mm

ES

En sus distintas versiones, el P-40B se utilizó en las fuerzas aéreas del ejército estadounidense a lo largo de toda la Segunda Guerra Mundial, luchando en Europa, toda Asia y en los desiertos del norte de África. El primer modelo que entró en servicio activo fue el P-40B, que demostró ser un caza de baja altura de gran efectividad y resistencia. Aunque no tenía la maniobrabilidad del Mitsubishi Zero japonés ni la velocidad del Messerschmitt Bf109 alemán, el P-40B fue un duro oponente. Los pilotos apreciaban su capacidad para regresar a la base incluso después de haber sufrido importantes daños, así como la potencia de disparo de sus seis ametralladoras. El P-40B se identificó con el motivo de boca de tiburón, utilizado en el Escuadrón 112 y en el Grupo de Voluntarios Norteamericanos en China. En la actualidad el P-40B sigue volando en Reino Unido y en su país de origen, Estados Unidos de América.

### Especificación:

Velocidad máxima: 560 km/h

Autonomía: 1200 km con carga máxima de combustible

Envergadura: 11.38 m

Longitud: 9.66 m

Armamento: : 4 ametralladoras Browning de calibre 0,30 y dos ametralladoras Browning de calibre 0.50

SV

I sina olika versioner användes P-40B av den amerikanska arméns flygvapen över Europa, Asien och Nordafrikas öknar under hela Andra världskriget. P-40B, den första modellen som användes i aktiv tjänst, visade sig vara ett effektivt och stridsfärdigt jaktplan på låg nivå. P-40B var inte lika manövrerbart som det japanska Mitsubishi Zero eller lika snabbt som det tyska Messerschmitt Bf109, men var ändå en tuff motståndare. Piloterna var speciellt tacksamma för planets förmåga att ofta kunna ta sig ändå hem även när det skadats svårt samt dess förmåga att åsamka fienden omfattande skador med sina sex kulsprutor. P-40B blev synonymt med ett hajkäftsmotiv under sin tjänstgöring i den 112:e divisionen och American Volunteer Group i Kina. Idag fortsätter P-40B att flygas i Storbritannien samt i sitt hemland USA.

### Specifikation:

Maximal hastighet: 560 km/h

Räckvidd: 1200 km med full tank

Spännvidd: 11.38 m

Längd: 9.66 m

Bestyckning: 4 st. 0,30-kalibers Browning-kulsprutor och 2 st. 0,50-kalibers Browning-kulsprutor

Airfix would like to thank the Fighter Collection ([www.fighter-collection.com](http://www.fighter-collection.com)) and Hume Bates for their assistance with this project.

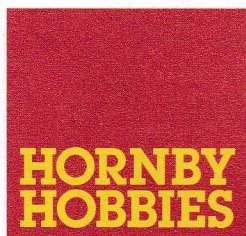

### FOR BEST RESULTS:

Surfaces to be painted should be clean — before parts are removed from the sprue, wash in warm, soapy water, rinse and dry thoroughly. Stir paints thoroughly before use.

### PLEASE NOTE:

Some parts in the kit may not be required to build the model specified.



Manufactured by: Hornby Hobbies Ltd Westwood, Margate, Kent, CT9 4JX, UK +44(0)1843 233525 [customerservices.uk@hornby.com](mailto:customerservices.uk@hornby.com)

EU Authorised Representative: Hornby Italia SRL Viale dei Caduti, 52/A6, Castel Mella (BS), Italy, 25030 +39 0687501292 [customerservices.it@hornby.com](mailto:customerservices.it@hornby.com)

# ASSEMBLY INSTRUCTIONS

**EN** Study drawings and practise assembly before cementing parts together. Carefully scrape paint from cementing surfaces. All parts are numbered. Paint small parts before assembly. To apply decals cut sheet as required, dip in warm water for a few seconds, slide off backing into position shown. Use in conjunction with box artwork. Not appropriate for children under 36 months of age, due to the presence of small detachable parts.

**FR** Étudier attentivement les dessins et simuler l'assemblage avant de coller les pièces. Gratter soigneusement toute peinture sur les surfaces à coller. Toutes les pièces sont numérotées. Peindre les petites pièces avant l'assemblage. Pour coller les décalcomanies, découper le motif, le plonger quelques secondes dans de l'eau chaude puis le poser à l'endroit indiqué en décollant le support papier. Utiliser conjointement avec les illustrations sur la boîte. Ne convient pas aux enfants de moins de 36 mois – présence de petits éléments détachables.

**DE** Vor dem Zusammenkleben der Teile die Zeichnungen sorgfältig ansehen und die zu verklebenden Teile zur Vermeidung möglicher Fehler versuchsweise zusammenfügen. Dann an den Klebeflächen vorhandene Farbbeschichtung vor dem Zusammenkleben vorsichtig abkratzen. Alle Bestandteile sind mit Nummern versehen. Kleine Teile vor dem Zusammenbau bemalen. Abziehbilder wie gewünscht ausschneiden. Vor dem Anbringen einige Sekunden in warmes Wasser tauchen und dann vom Trägerpapier in ihre vorgesehene Position schieben. Dabei die Abbildungen auf der Schachtel beachten. Nicht für Kinder unter 36 Monaten geeignet, da abnehmbare bzw. lose angebrachte Kleinteile enthalten sind.

**ES** Estudiar los dibujos y practicar el montaje antes de pegar las piezas. Raspar cuidadosamente la pintura en las superficies de contacto antes de pegar las piezas. Todas las piezas están numeradas. Es conveniente pintar las piezas pequeñas antes de su montaje. Para aplicar las calcomanías, cortarlas de la hoja, sumergirlas en agua tibia durante unos segundos y deslizarlas a la posición indicada. Utilizar en conjunción con la ilustración de la caja. No es adecuado para niños menores de 36 meses, ya que contiene piezas pequeñas que podrían soltarse.

**SV** Studera bilderna noggrant och sätt ihop delarna innan du limmar ihop dem. Skrapa försiktigt bort färg från limmade delar. Alla delarna är numerade. Måla smådelarna före ihopsättning. Sätt fast dekalerna genom att klippa arket, doppa i varmt vatten några sekunder och låta baksidan glida på plats som bilden visar. Använd enligt bildanvisningarna på kartongen. Rekommenderas ej för barn under 3 år. Innehåller löstagbara smådelar.

**NL** Tekeningen bestuderen en delen in elkaar zetten alvorens deze te lijmen. Lak voorzichtig van lijmvlakken afschrapen. Alle delen zijn genummerd. Kleine delen vóór montage verven. Voor aanbrengen van stickers, gewenste stickers uit het vel knippen, een paar seconden in warm water dompelen en dan van het schutblad af op afgebeelde plaats schuiven. Hierbij afbeelding op doos raadplegen. Niet geschikt voor kinderen onder 3 jaar, omdat kleine deeltjes gemakkelijk kunnen losraken.

**PO** Przed przystąpieniem do sklejania przestuduj uważnie rysunki i przećwicz składanie części. Ostrożnie zeskrub ze sklejanych powierzchni farbę. Wszystkie części są ponumerowane. Drobne części pomaluj przed ich złożeniem. Celem przeniesienia kalkomanii wytnij ją z arkusza, zanurz na kilka sekund w letniej wodzie i zsuń z podłoża na wymagane miejsce. Używaj w połączeniu ze wzorami na pudełku. W związku z obecnością wielu drobnych, rozbieralnych części, nieodpowiednie dla dzieci poniżej 3 lat.

**IT** Studiare i disegni ed esercitarsi a montare i vari pezzi prima di fissarli con la colla. Raschiare con cura le tracce di vernice dalle superfici da incollare. Tutti i pezzi sono numerati. Verniciare i pezzi di piccole dimensioni prima di montarli. Per applicare le decalcomanie, ritagliare il foglio nel modo richiesto, immergere in acqua calda per alcuni secondi, quindi staccare la decalcomania dalla carta di supporto e posizionarla nel punto desiderato. Usare le decalcomanie come indicato nell'illustrazione riportata sulla confezione. Non adatto a bambini di età inferiore a 36 mesi per la presenza di componenti di piccole dimensioni che potrebbero staccarsi.

**PT** Estudar atentamente os desenhos e experimentar a montagem. Raspar cuidadosamente as superfícies de modo a eliminar pintura antes de colar. Todas as peças estão numeradas. Pintar as pequenas peças antes de colar. Para aplicar as decalcomanias, cortar as folhas e mergulhar em água morna por alguns segundos, depois deslizar e aplicar no respectivo lugar, como indicado nas ilustrações na caixa. Não convém a uma criança de menos de 36 meses devido à presença de pequenos elementos destacáveis.

**EL** Μελετήστε προσεκτικά τα σχέδια και συναρμολογήστε για πρώτη φορά τα κομμάτια χωρίς να τα συγκολλήσετε. Αφαιρέστε επιμελώς την πλαστική βαφή από τις επιφάνειες τις οποίες θα συγκολλήσετε. Όλα τα κομμάτια είναι αριθμημένα. Χρωματίστε τα μικρά κομμάτια πριν από τη συναρμολόγηση. Για να κολλήσετε τις χαλκομανίες, κόψτε γύρω από το σχέδιο όπως απαιτείται, βυθίστε το μερικά δευτερόλεπτα σε χλιαρό νερό και μετά τοποθετήστε το στη θέση που υποδεικνύεται, αφαιρώντας τη μεμβράνη που το καλύπτει. Λάβετε υπόψη σας ταυτόχρονα την εικονογράφηση του κουτιού. Ακατάλληλο για παιδιά ηλικίας κάτω των 36 μηνών λόγω ύπαρξης μικρών κομματιών που αποσπώνται.

**FI** Tutustu piirroksiin ja harjoittele kokoamista, ennen kuin liimaat osat yhteen. Raaputa maali varovasti pois liimattavilta pinnolta. Kaikki osat on numeroitu. Maalaa pienet osat ennen kokoamista. Siirtokuvien kiinnittämiseksi leikkaa ne arkista tarpeen mukaan. Kasta kuva lämpimään veteen muutaman sekunnin ajaksi, anna takapuolen liukua kovalle osoitettuun kohtaan. Käytetään yhdessä laatikon kuvituksen kanssa. Ei suositella alle kolmivuotiaille lapsille. Paljon irrotettavia pikkuosia.

**DA** Studér tegningerne nøje og forsøg at sætte delene sammen, inden de klæbes sammen. Skrab forsigtigt malingen af de overflader, der skal klæbes sammen. Alle dele er nummererede. Små dele skal males, før de monteres. Overføringsbillederne påføres ved at klippe dem ud af arket, som påkrævet, dypp dem i varmt vand i nogle få sekunder, hvorefter underlaget glides af i de viste positioner. Påføres ifølge illustrationerne på æsken. Ikke egnet til børn under 3 år på grund af tilstedeværelse af små aftagelige dele.

# ASSEMBLY ICON INSTRUCTIONS

<p>Assembly phase Phase de montage Montagephase Fase de montaje Monteringsfasen Fase di montaggio Montagefase Fase de montagem Monteringsfase Kokoamisvaihe Faza składowania Φάση συναρμολόγησης</p> 	<p>Cement Coller Kleben Pegar Limma Incollare Lijmen Colar Klæbes Liimaa Kleic Συγκολλήστε</p> 	<p>Do not cement together No pas coller Nicht kleben No pegar Limma inte Non incollare Niet lijmen Não colar Skal ikke klæbes Älä liimaa Nie kleic Μη συγκολλήσετε</p> 	<p>Indicates final location Indique l'emplacement final Zeigt Endposition Indica la ubicación definitiva Anger slutmonteringsplats Sede di montaggio finale Geeft uiteindelijke locatie aan 'Indica localização final Viser endelig placering Osoittaa lopullisen sijainnin Oznacza miejsce docelowe Υποδεικνύει τελική τοποθεσία</p> 	<p>Alternative part(s) provided Autre(s) pièce(s) fournie(s) Ersatzteil(e) mitgeliefert Se incluye(n) pieza(s) alternativa(s) Alternativ(a) del(ar) ingår Uno o più componenti alternativi forniti Alternative onderdelen meegeleverd Peça(s) alternativa(s) fornecida(s) Alternativ(e) del(e) medfølger Vaihtoehtoiset osat pakkauksessa Dostępne części zamienne Παρέχονται εναλλακτικά κομμάτια</p> 	<p>Repeat this operation Répéter l'opération Vorgang wiederholen Repitir a operação Upprepa åtgärden Ripetere l'operazione De verrichting herhalen Repitir a operação Manövrer gentages Toista toimenpide Powtórzyc operację Επαναλάβετε τη διαδικασία</p> 	
<p>Decals Décalcomanias Abziehbild Calcomanias Dekaler Decalcomanie Stickers Decalcomania Billedoverføring Siirtokuvat Kalkomanie Χαλκομανίες</p> 	<p>Crystal part Pièce cristal Kristallteil Pieza de cristal Kristalldel Pezzo cristallo Kristallen onderdeel Peça de cristal Krystalstykke Kristalliosa Część kryształowa Κομμάτι κρυστάλλου</p> 	<p>Weight Lester Beschweren Lastrar Belasta Applique un peso Verzwaren Lastrar Påfør vægt Aseta vastapaino Obciążyc balastem Επιθέστε βάρος</p> 	<p>Remove by filing Enlever avec une lime Abfeilen Eliminar con lima Ta bort genom att fila Rimuovere con la lima Verwijderen door afvijlen Removea limando Fjern ved at file væk Poista villaamalla Usunąć przy użyciu pilnika Αφαιρέστε λιμάροντας με λίμα</p> 	<p>Drill or pierce Perçer Durchbohren Perforar Borra Trapanare o forare Boren of doorboren Furar Gennembor Poraa tai puhkaise Wywiercić lub przedziurawić Τρυπήστε</p> 	<p>Cut Découper Schneiden Cortar Skär Tagliare Snijden Cortar Skær Leikkaa Przeciąć Κόψτε</p> 	<p>Humbrol paint number No peinture Humbrol Humbrol-Farbnummer No de pintura Humbrol Humbrol färg nummer No vernice Humbrol Humbrol verfnummer No de pintura Humbrol Humbrol malingsnummer Humbrol-maalin numero Nr farby Humbrol Νόμepo χρώματος Humbrol</p> 

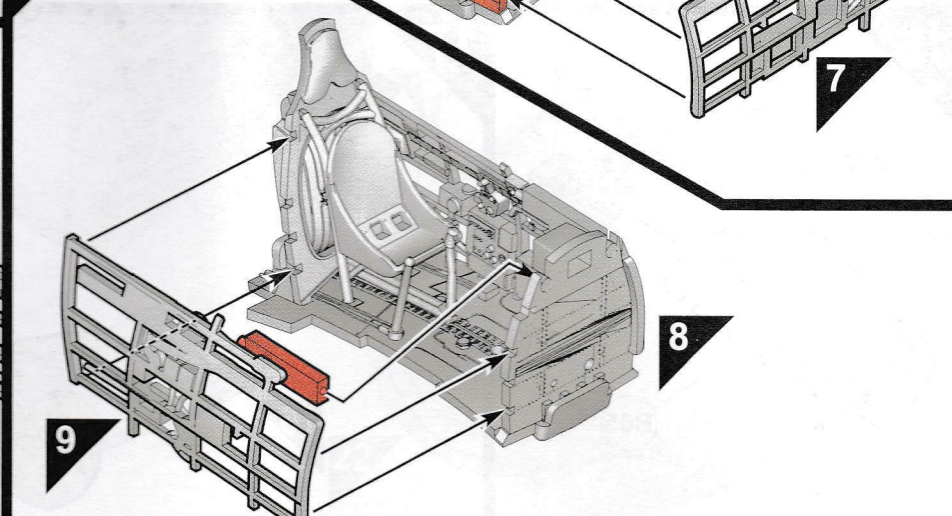
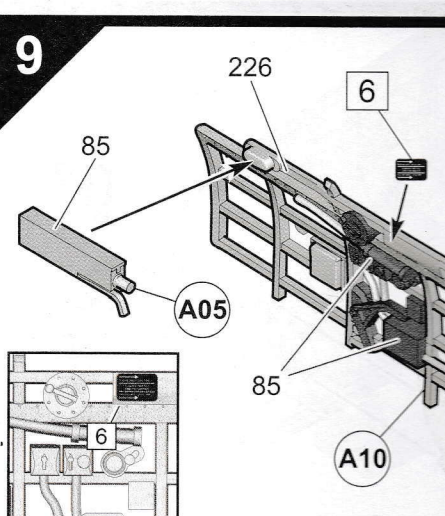
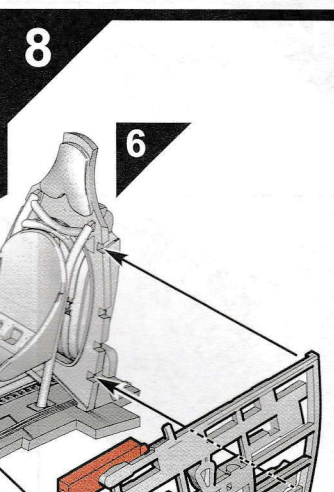
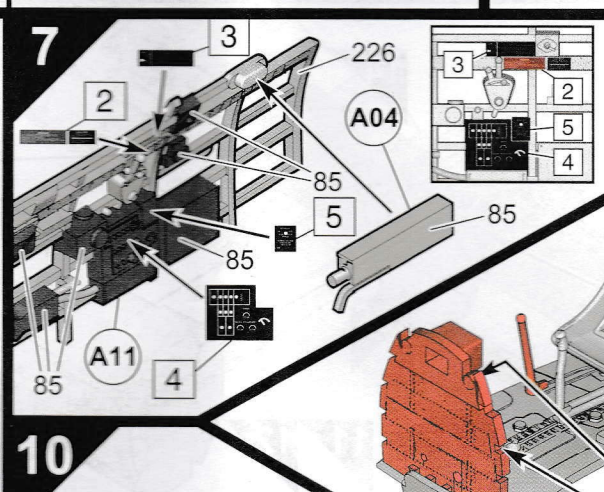
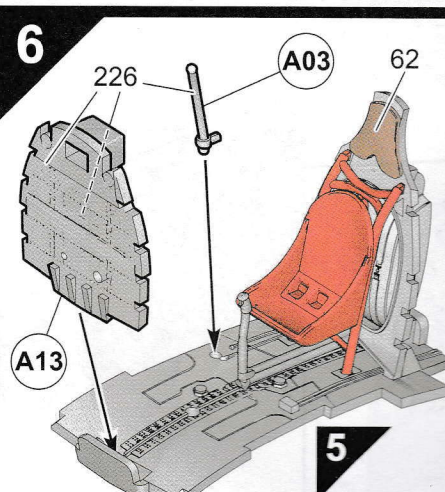
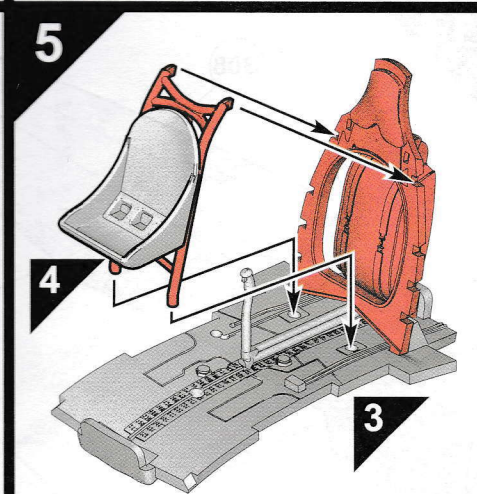
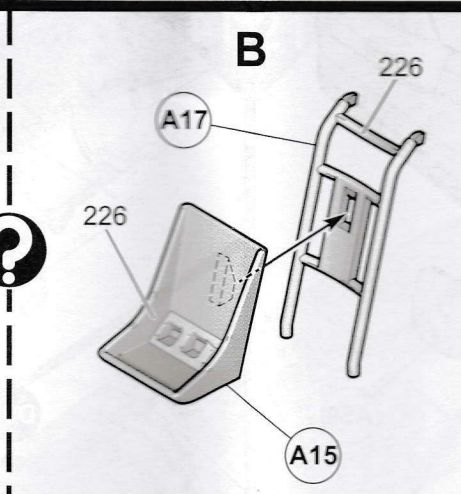
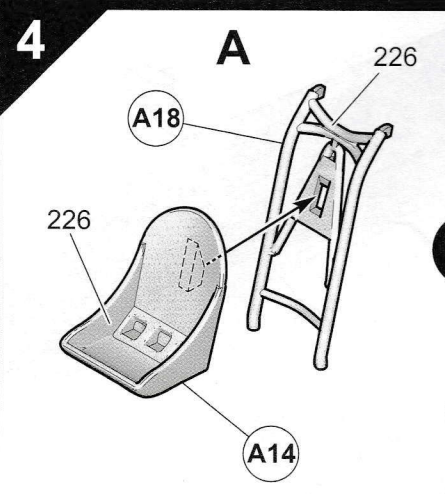
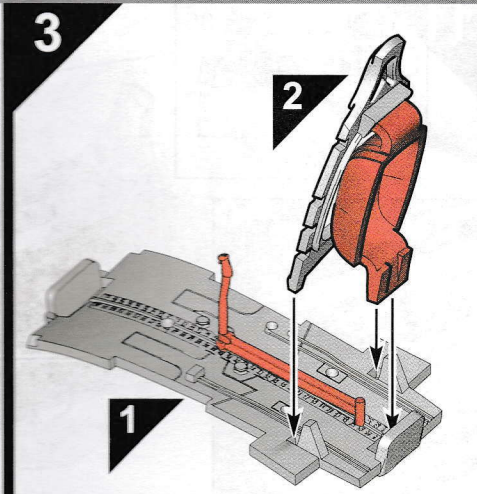
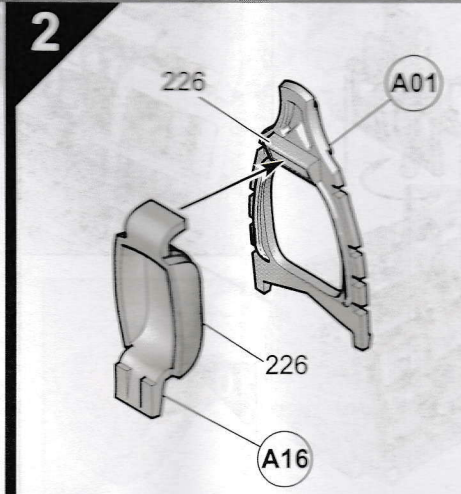
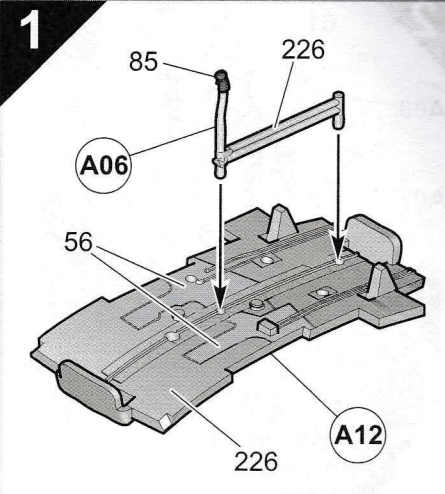
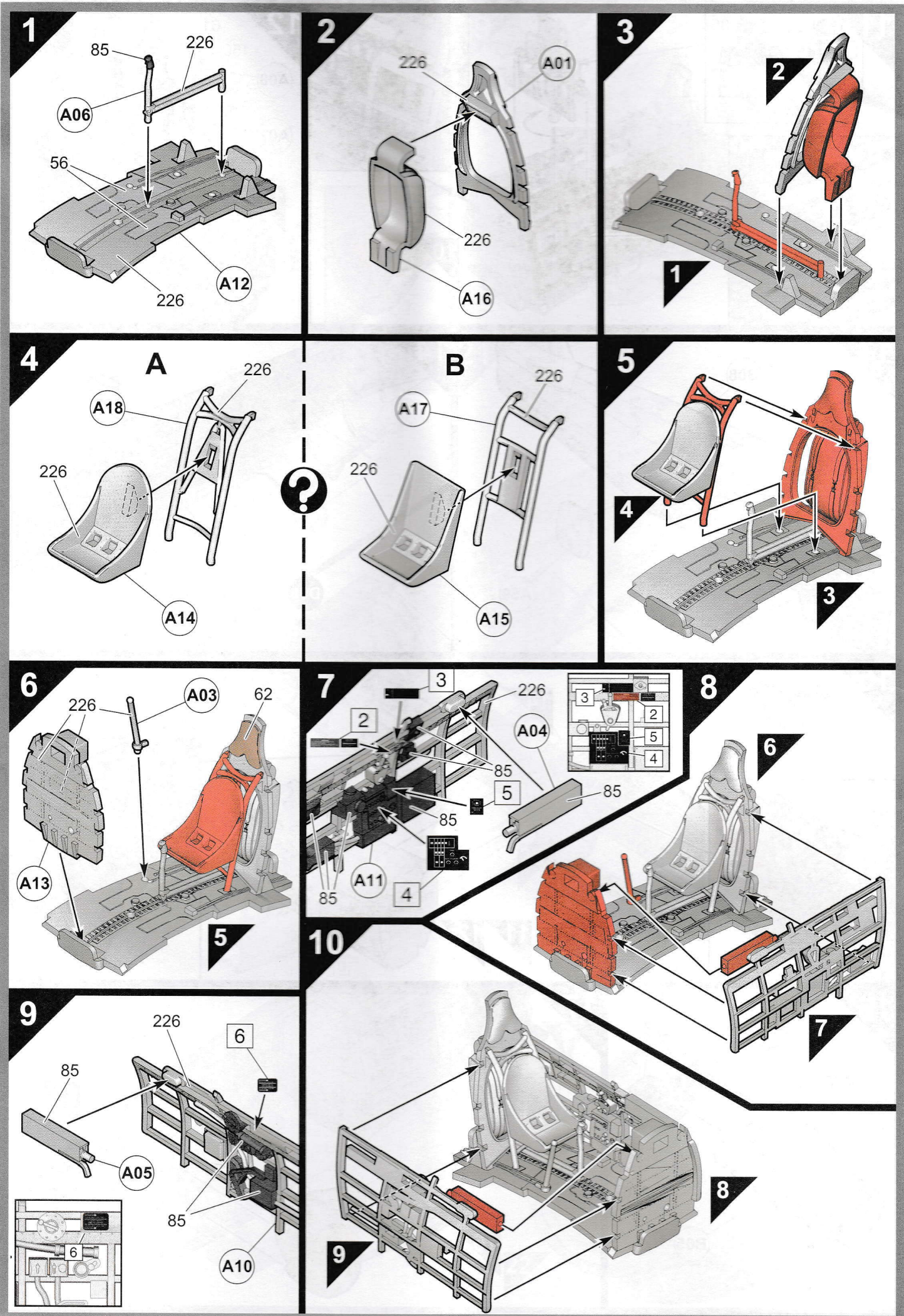

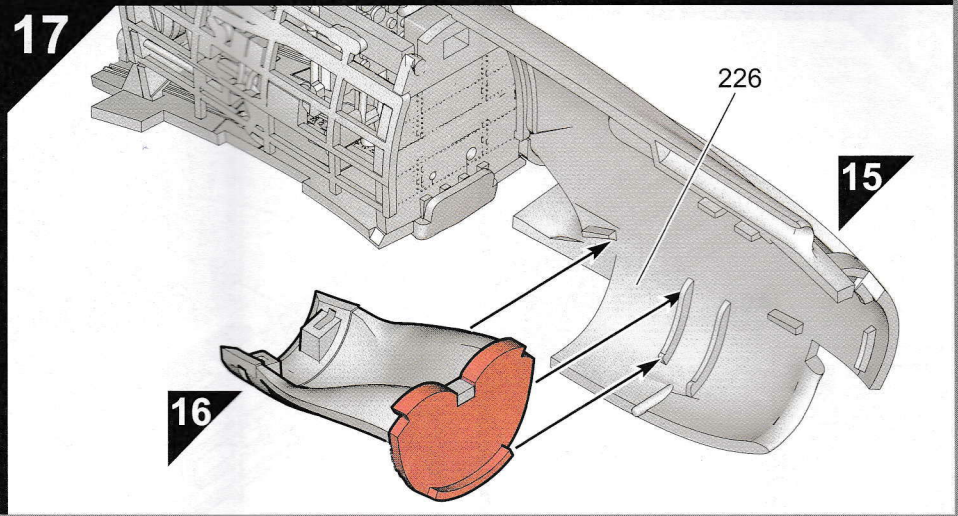
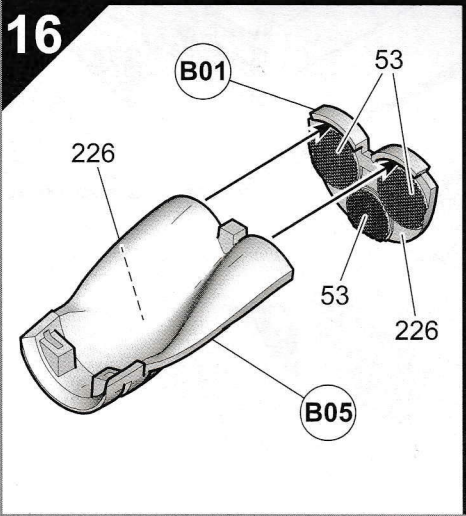
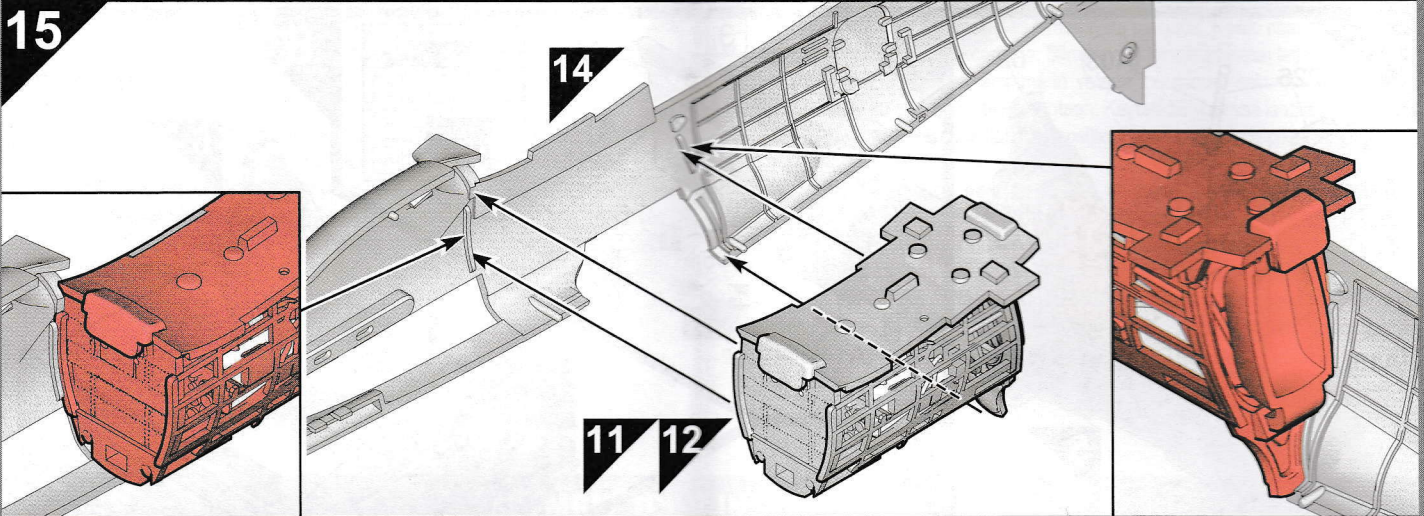
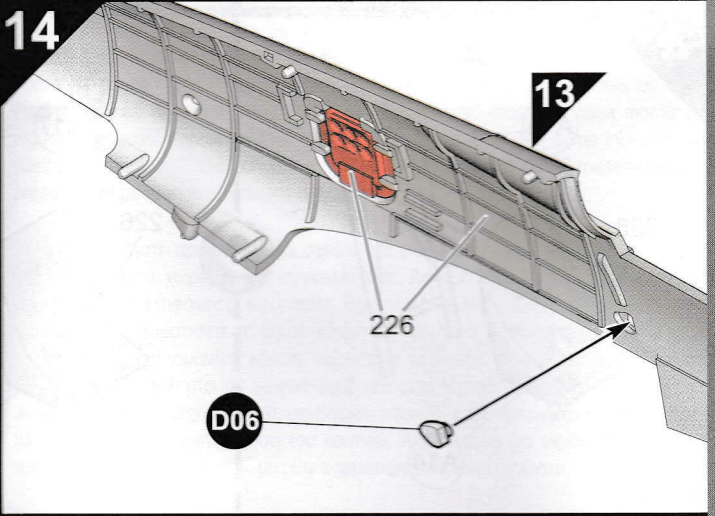
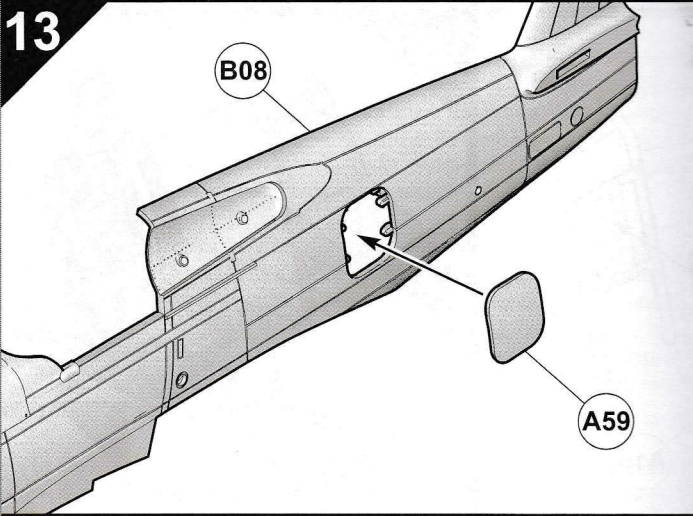
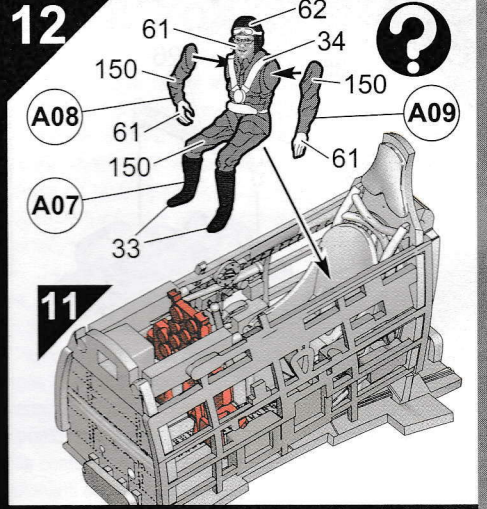
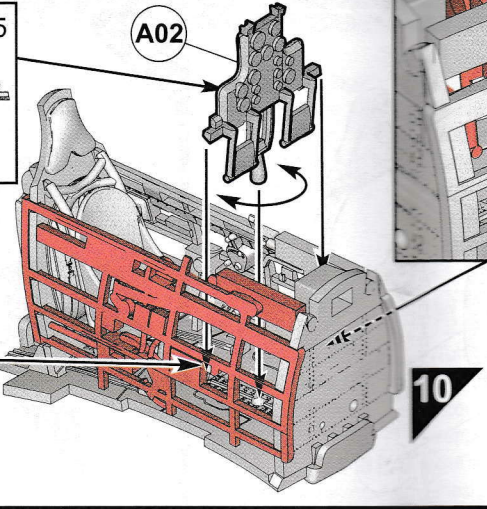
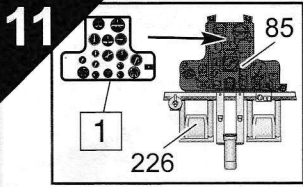

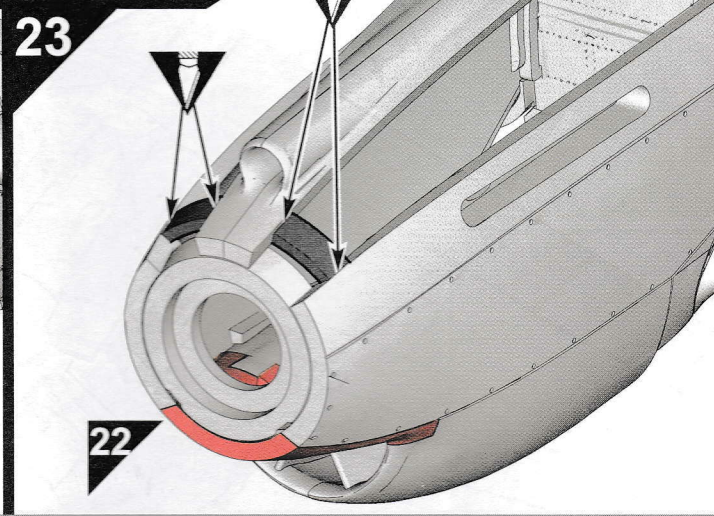
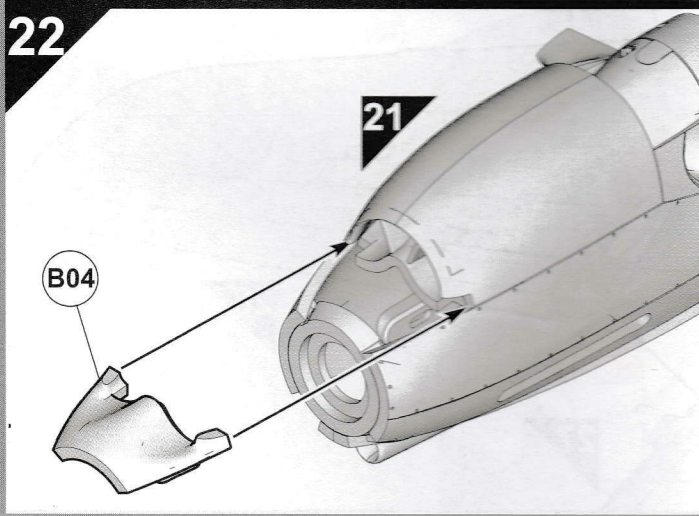
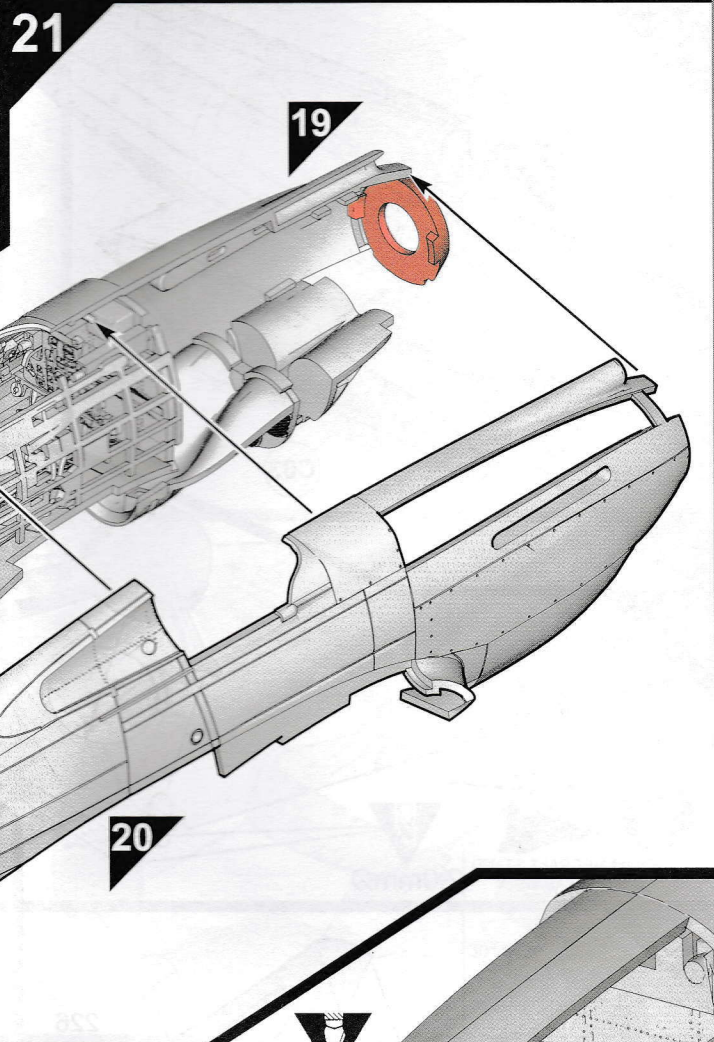
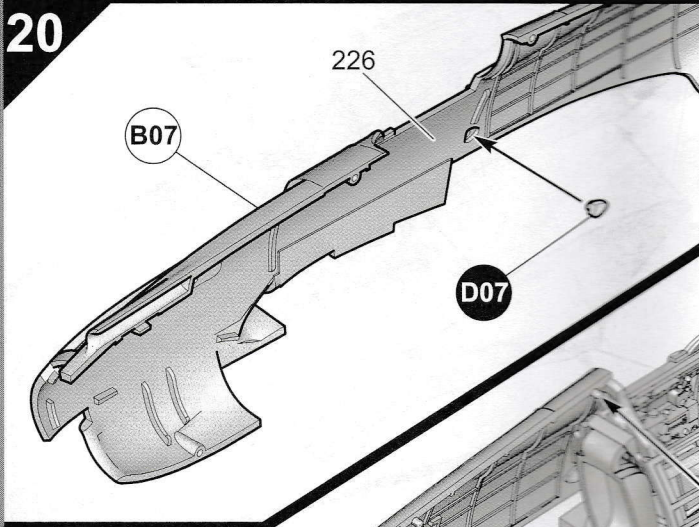
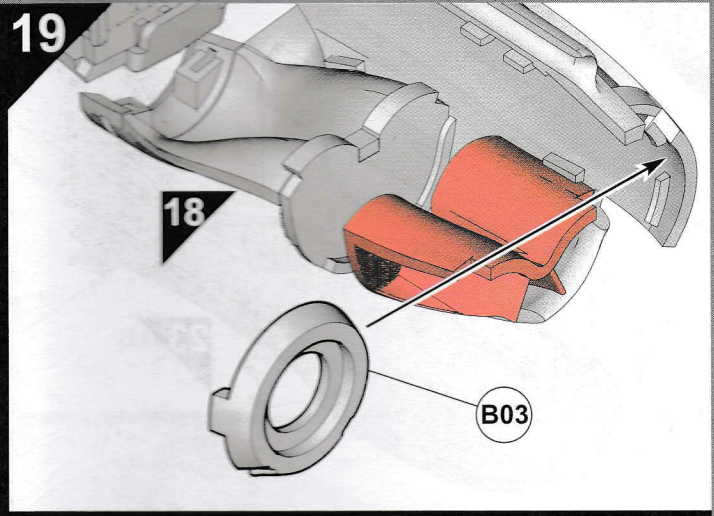
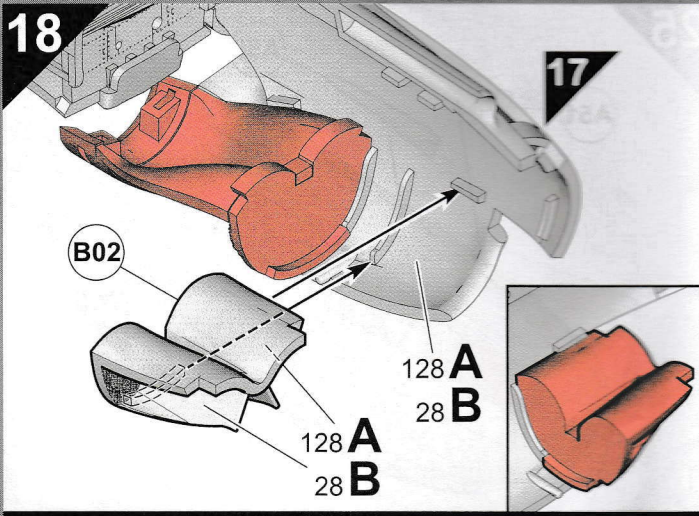

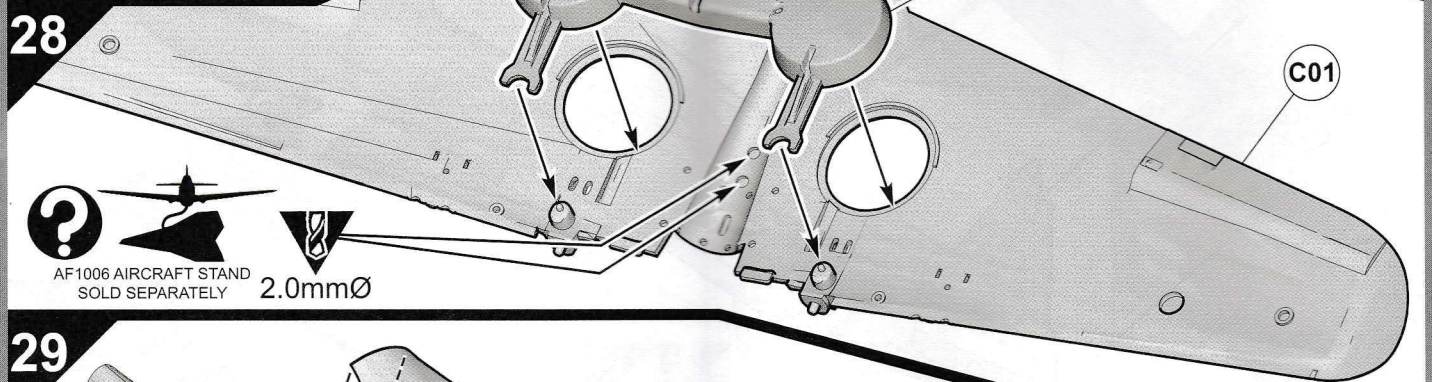
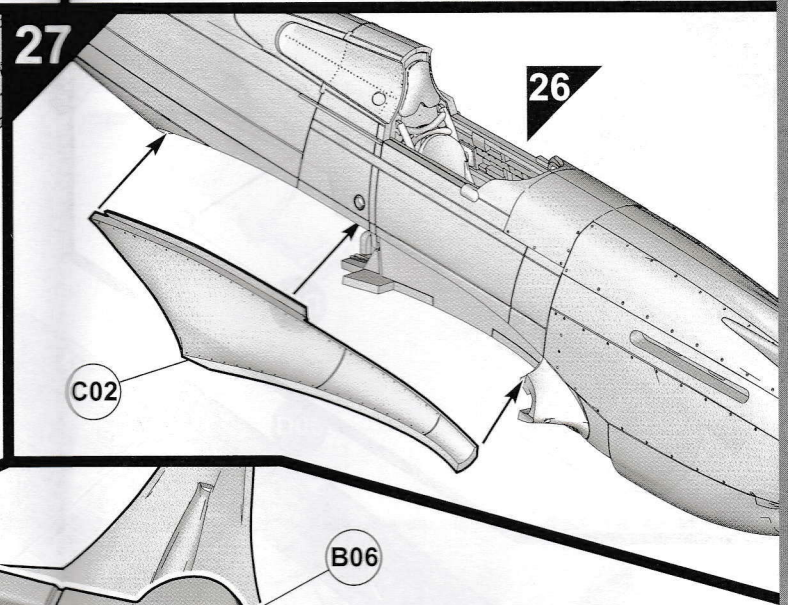
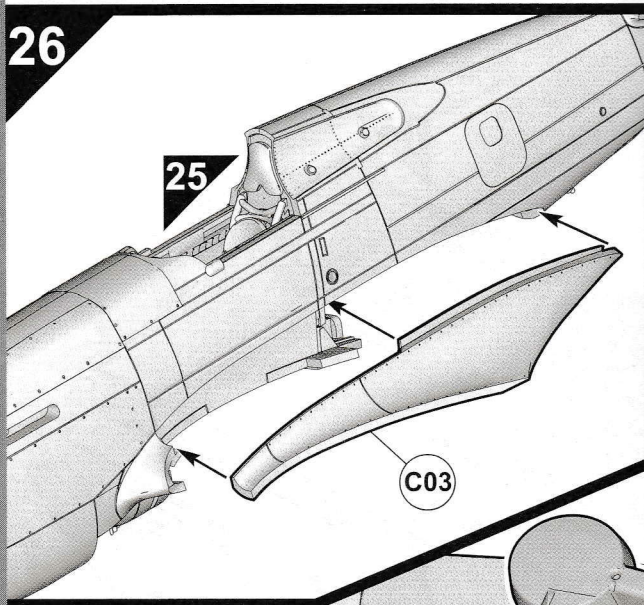
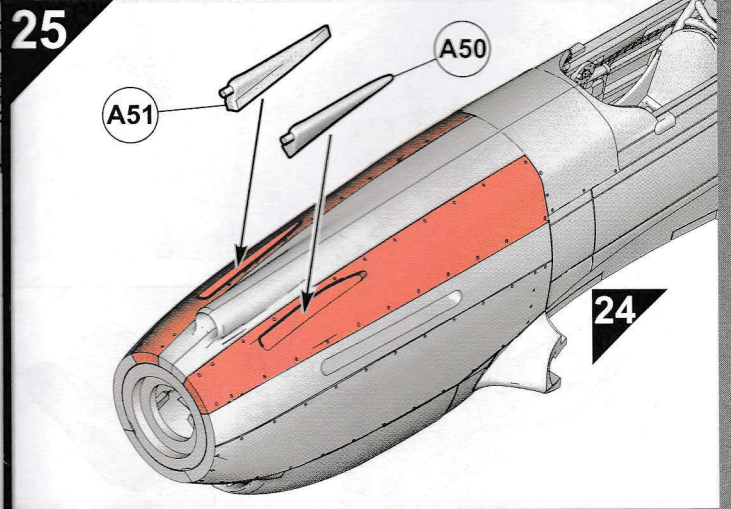
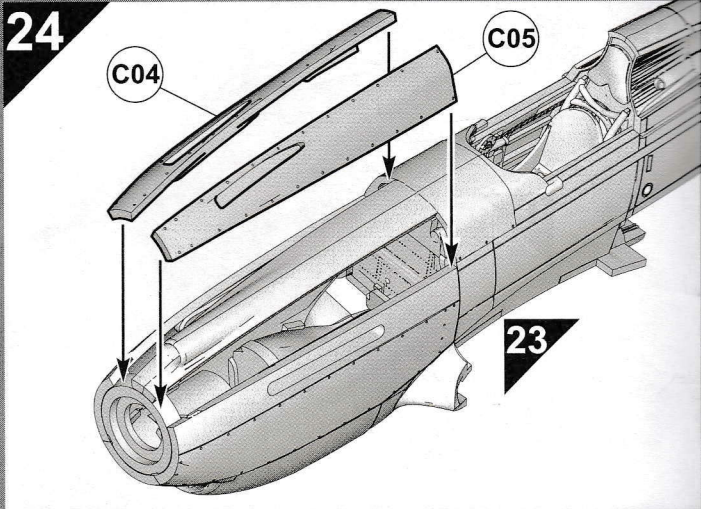

**?** **AF1006 AIRCRAFT STAND SOLD SEPARATELY**

**2.0mmØ**

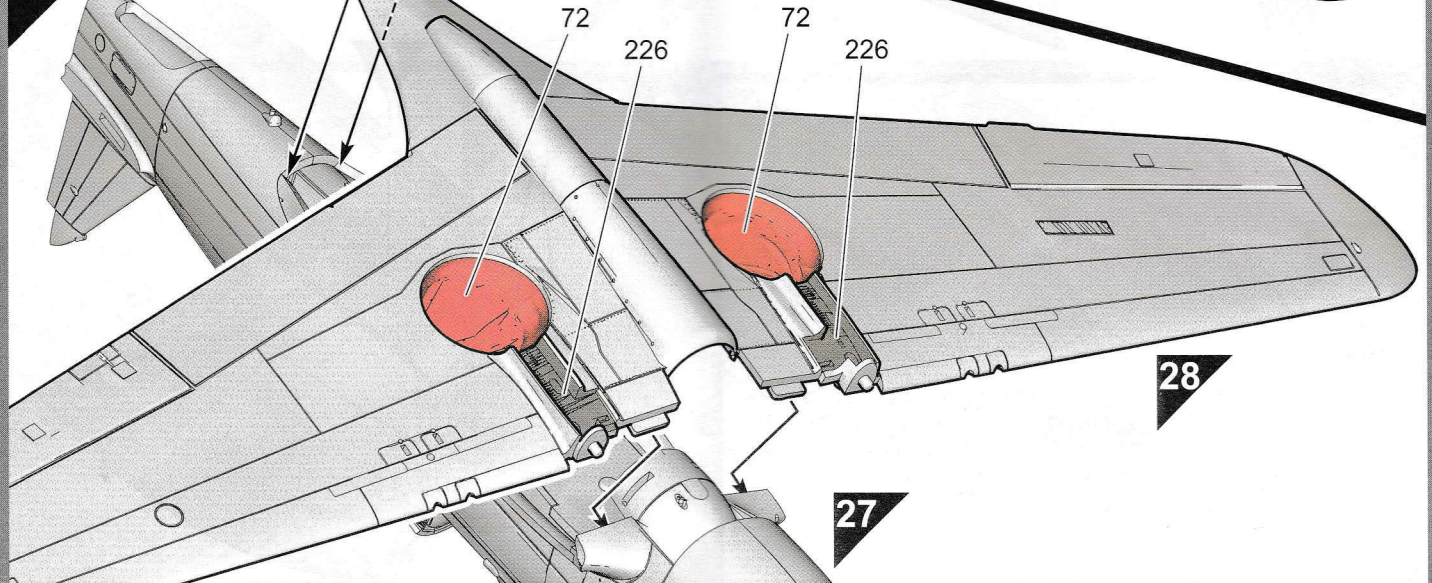

30

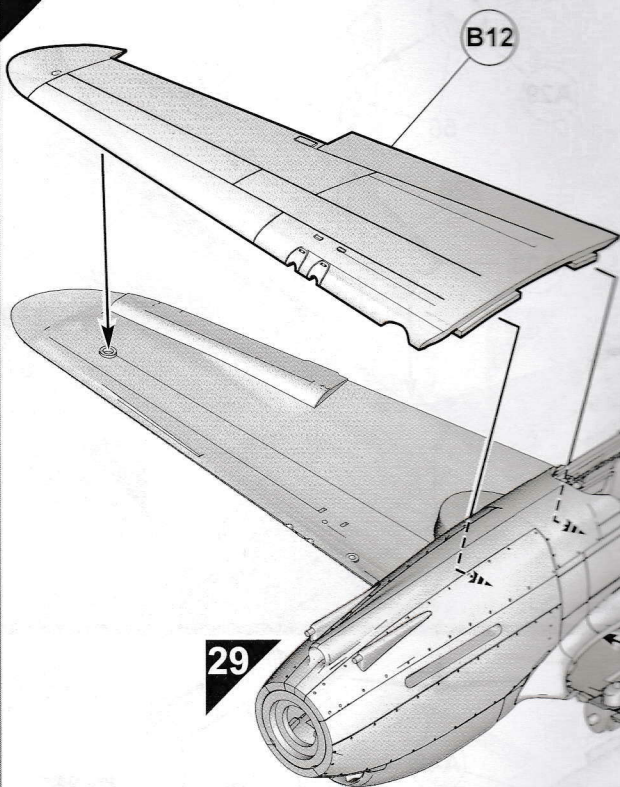

31

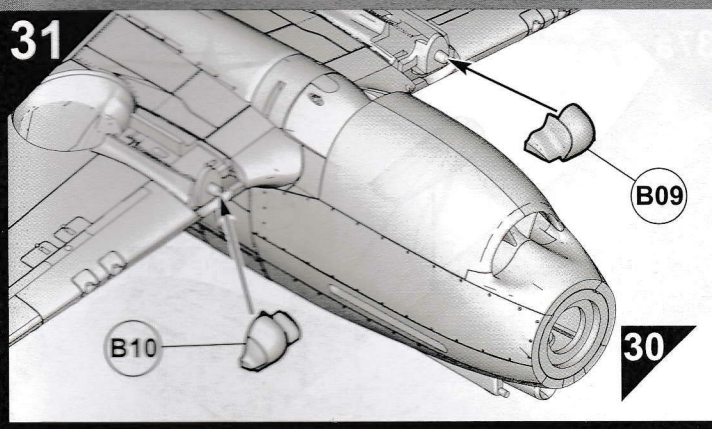

29

30

B11

32

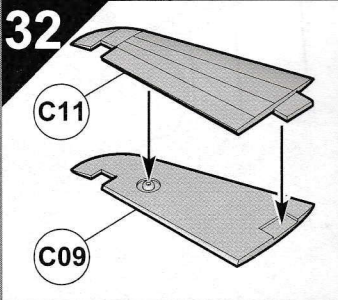

33

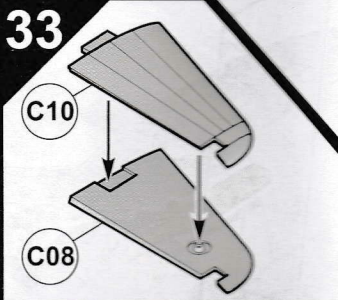

34

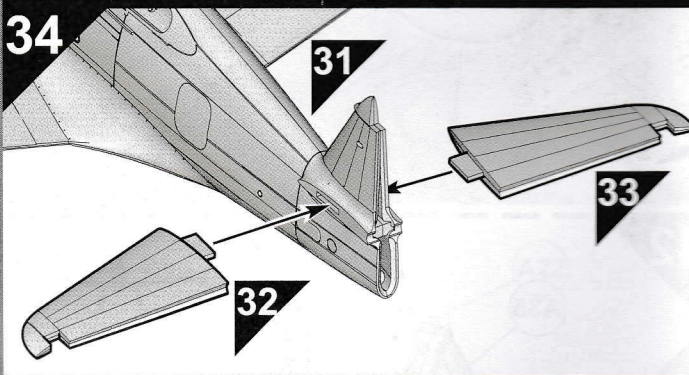

35

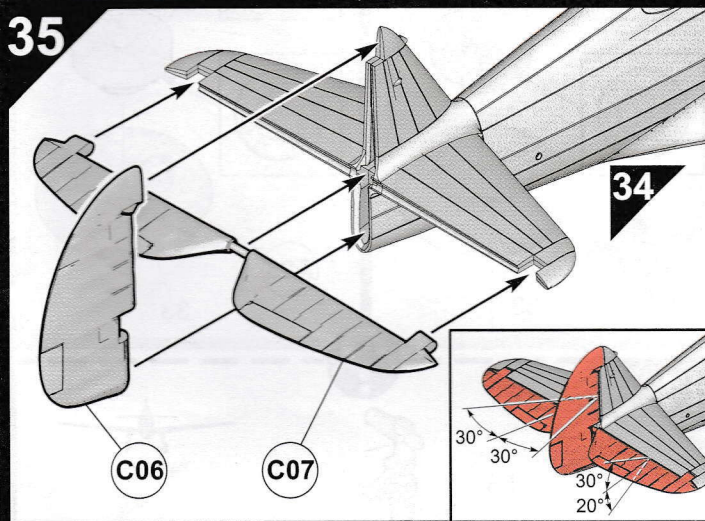

36

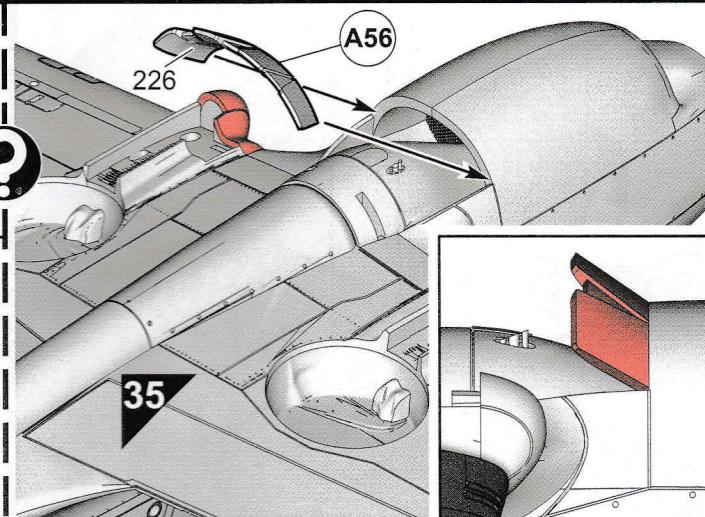
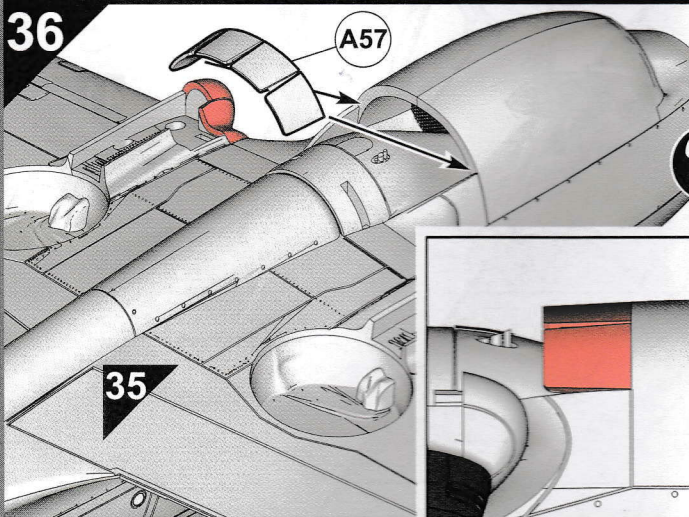

37a

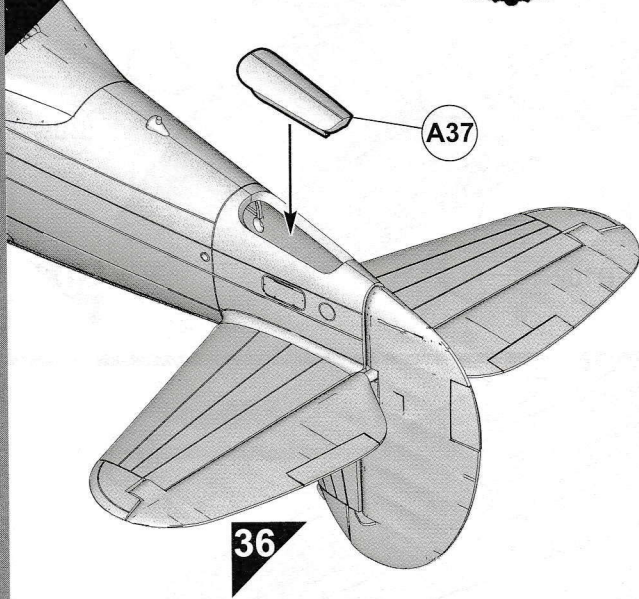

37b

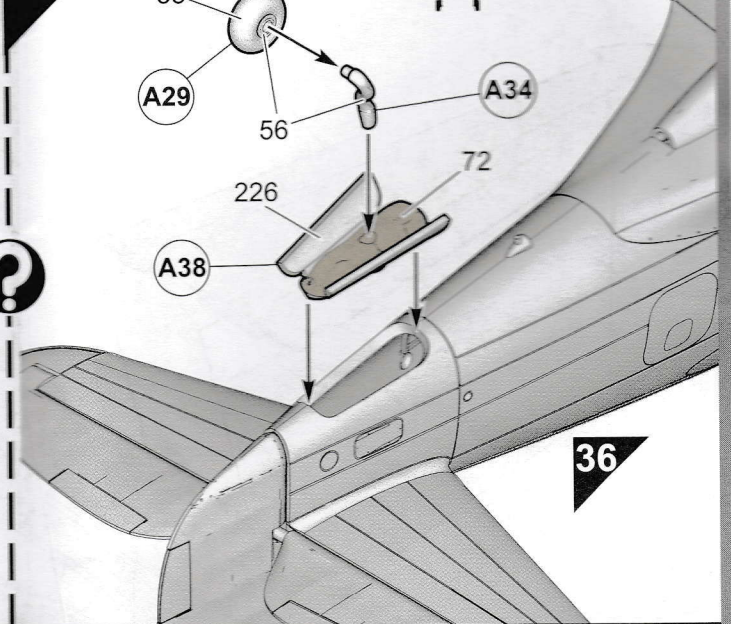

38

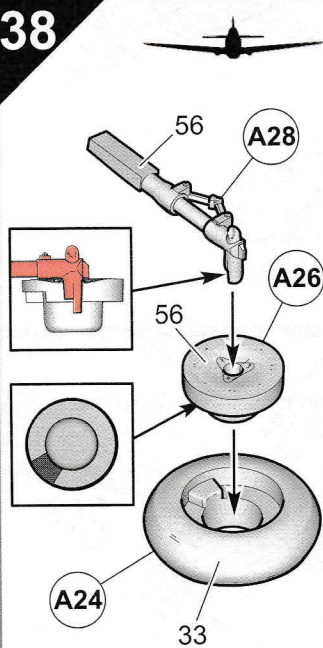

39

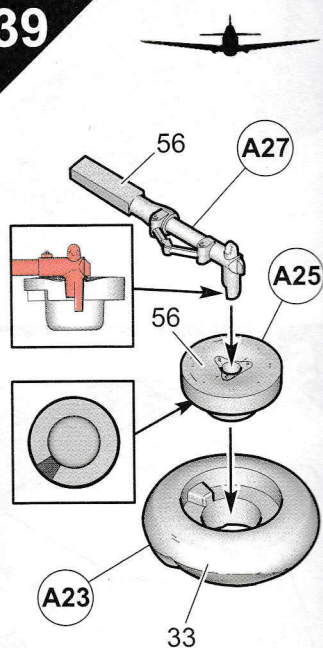

40

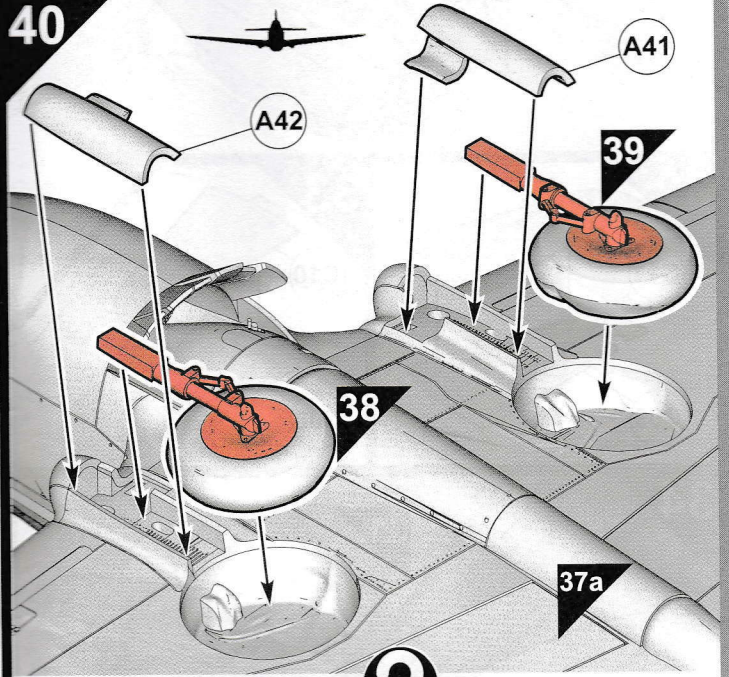

41

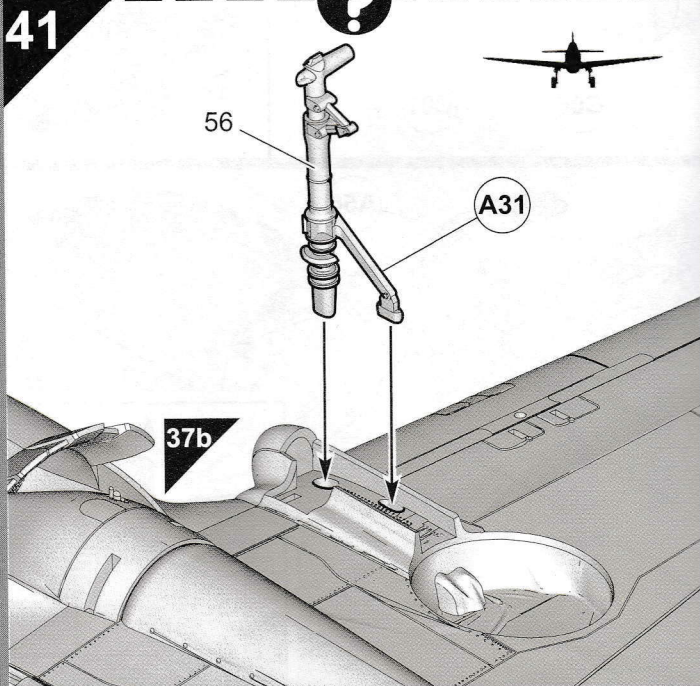

42

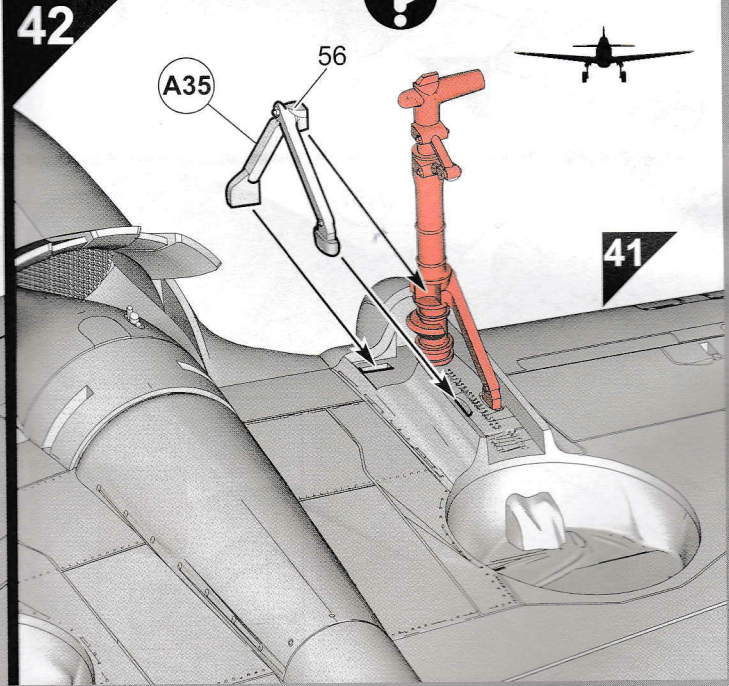



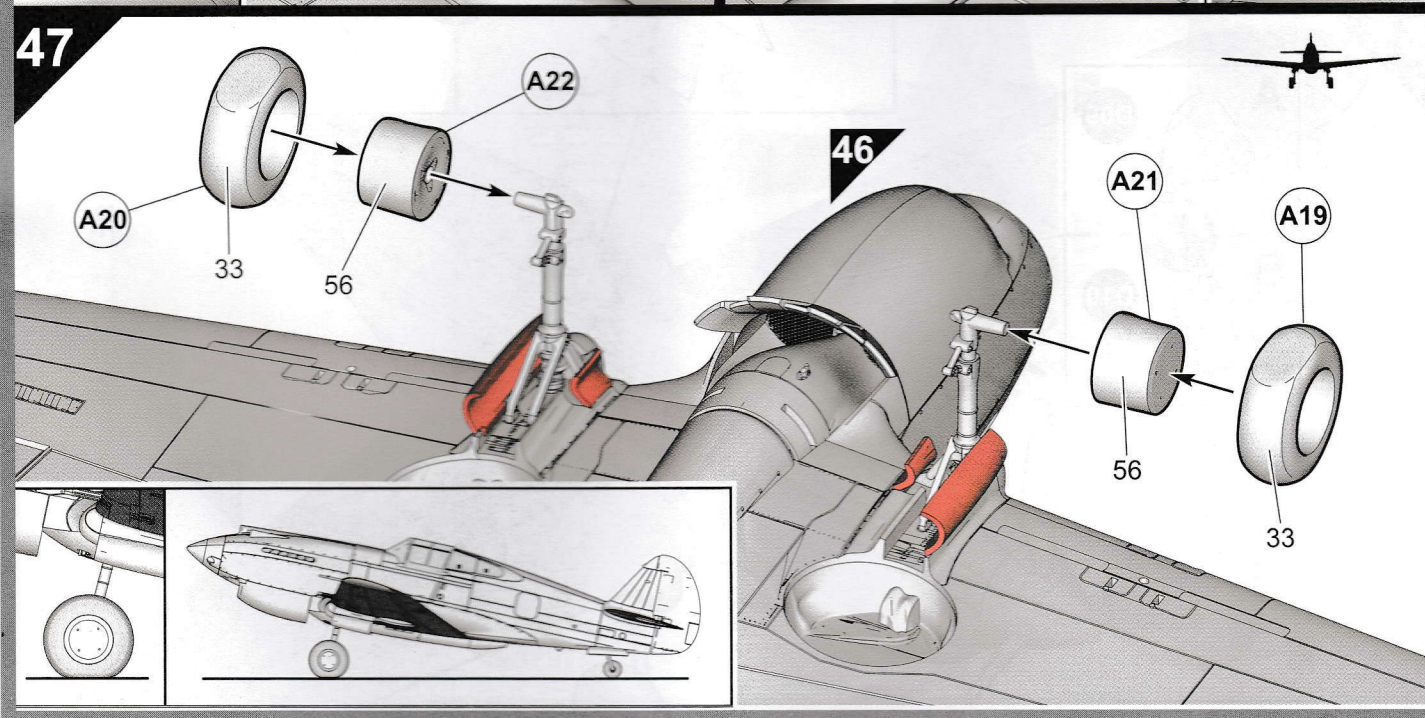
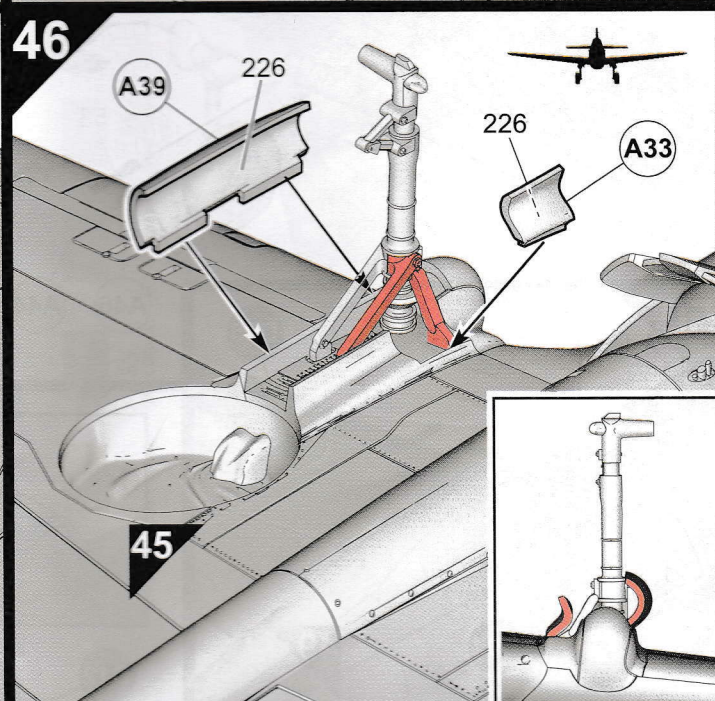
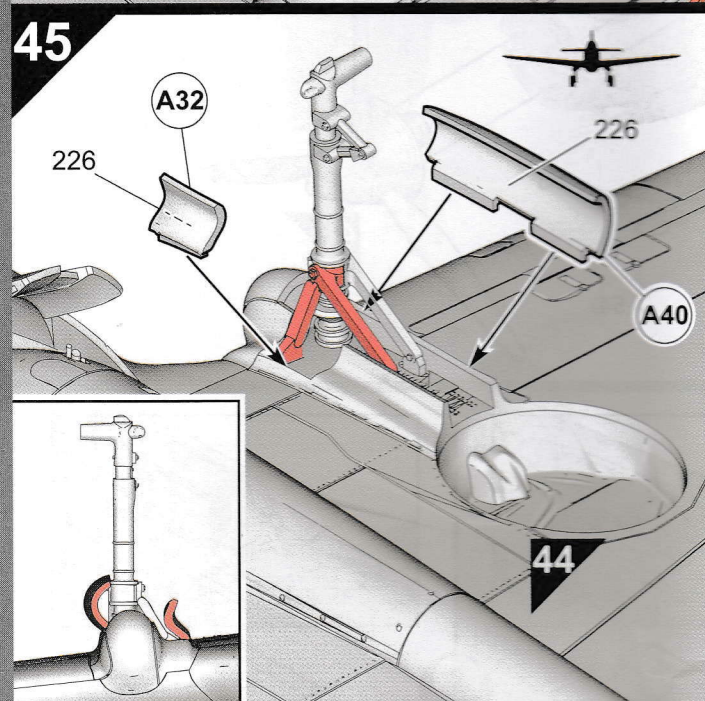
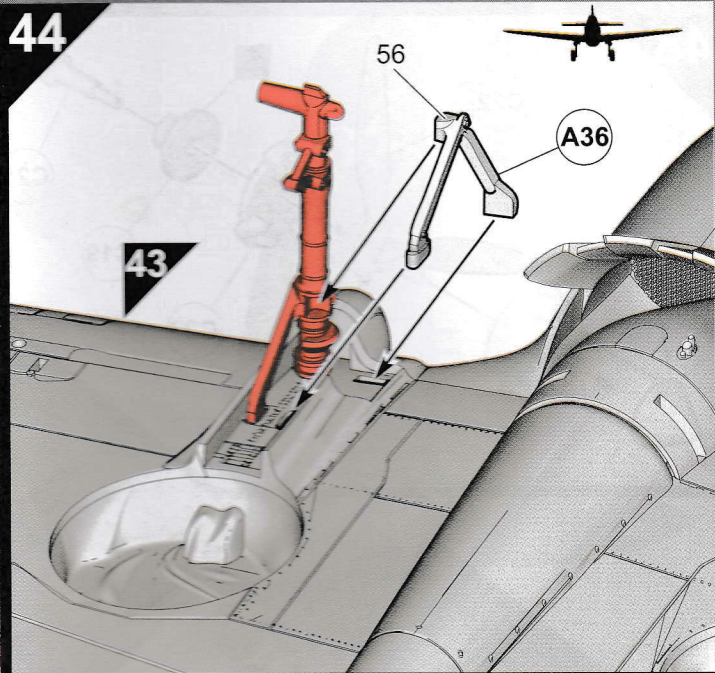
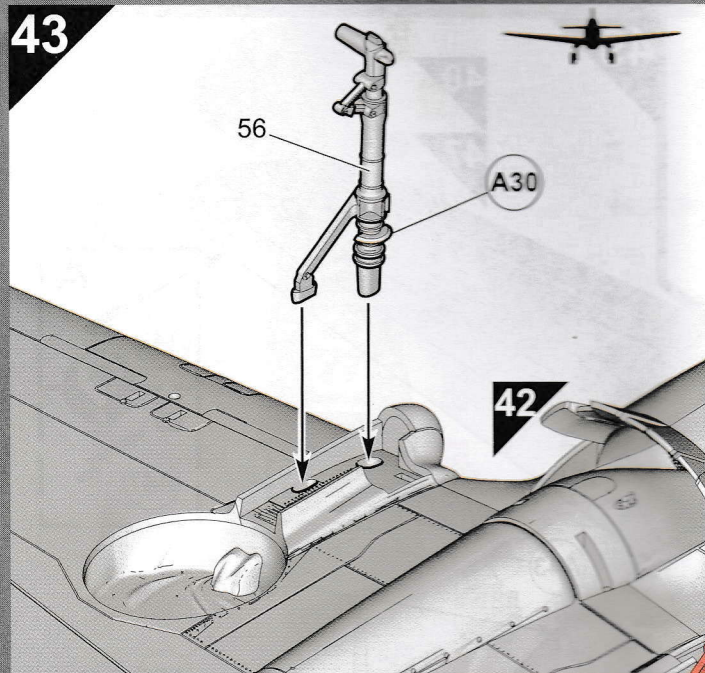

48

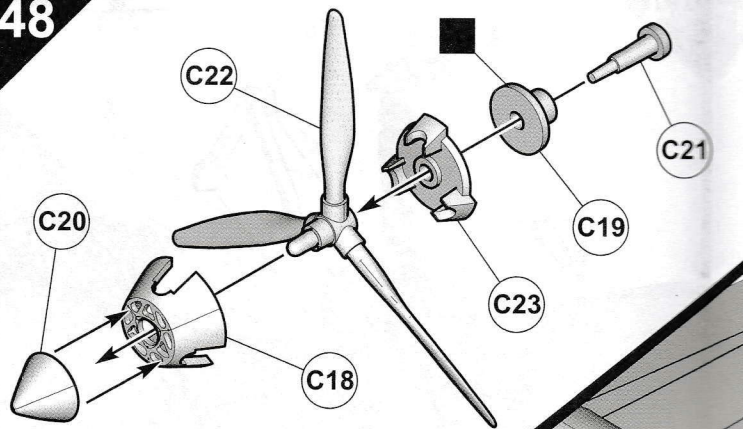

49

40

47

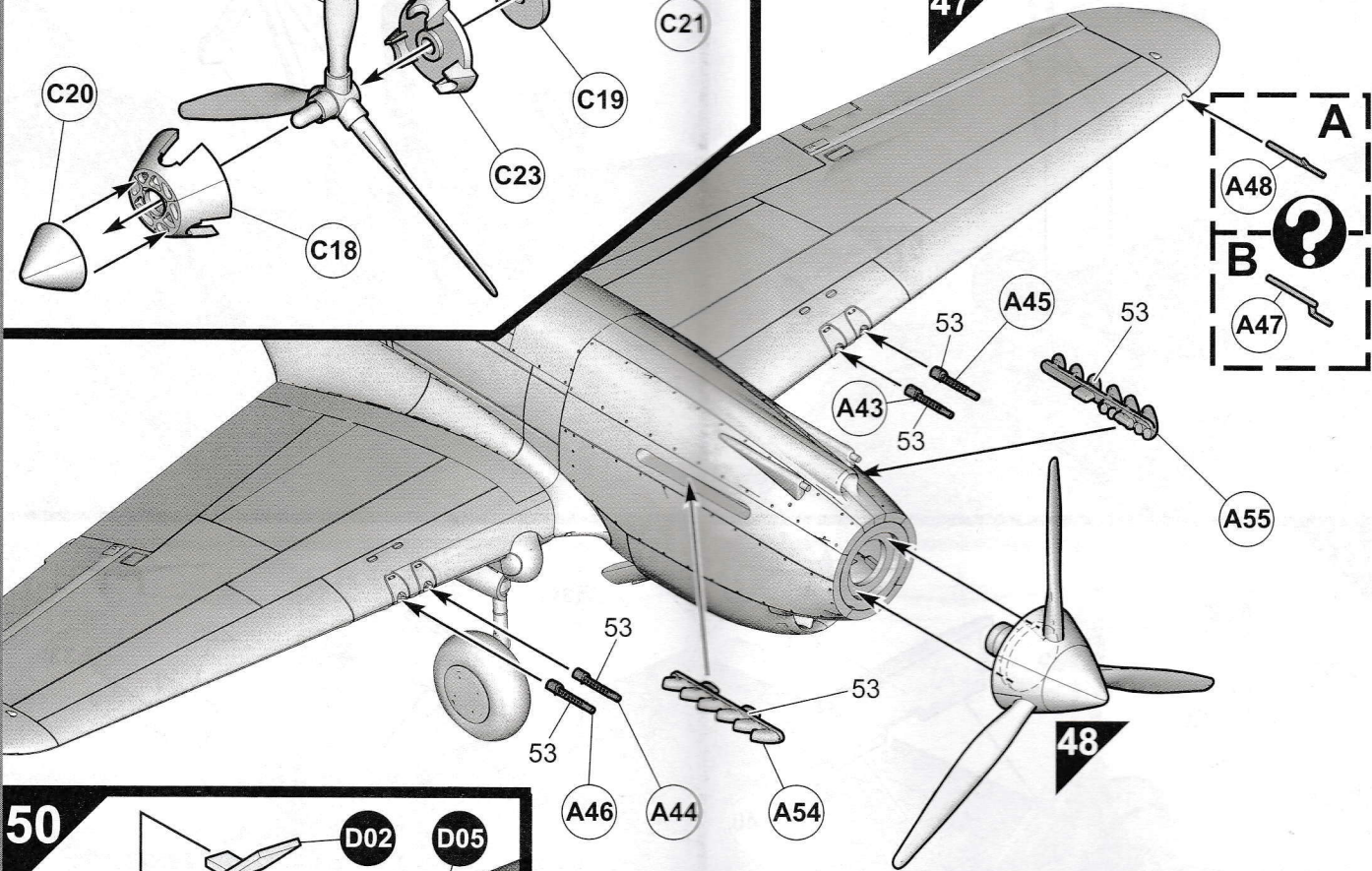

50

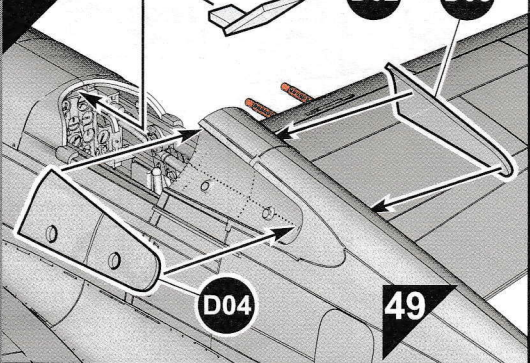

49

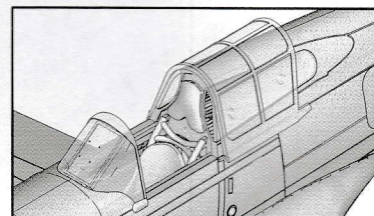
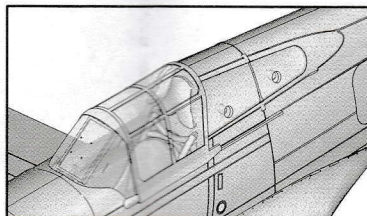

D12

?

D11

51

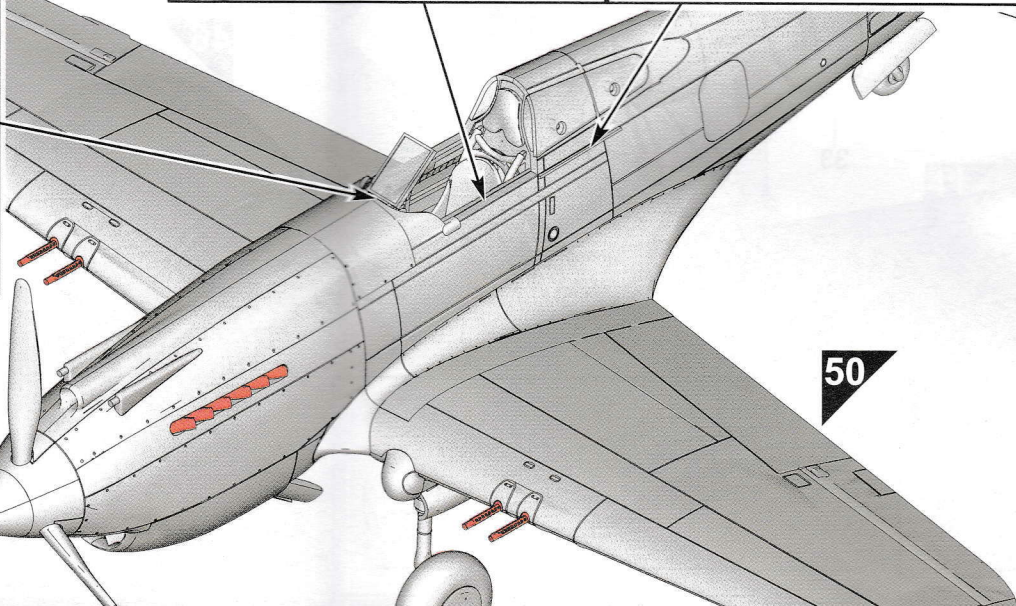
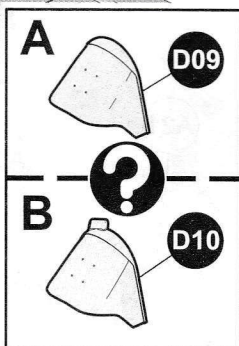

50

# A Curtiss P-40B Warhawk

Flown by 2nd Lt. George Welch, 47th Pursuit Squadron, 15th Pursuit Group, Wheeler Field, Oahu, Hawaii, December 7, 1941.

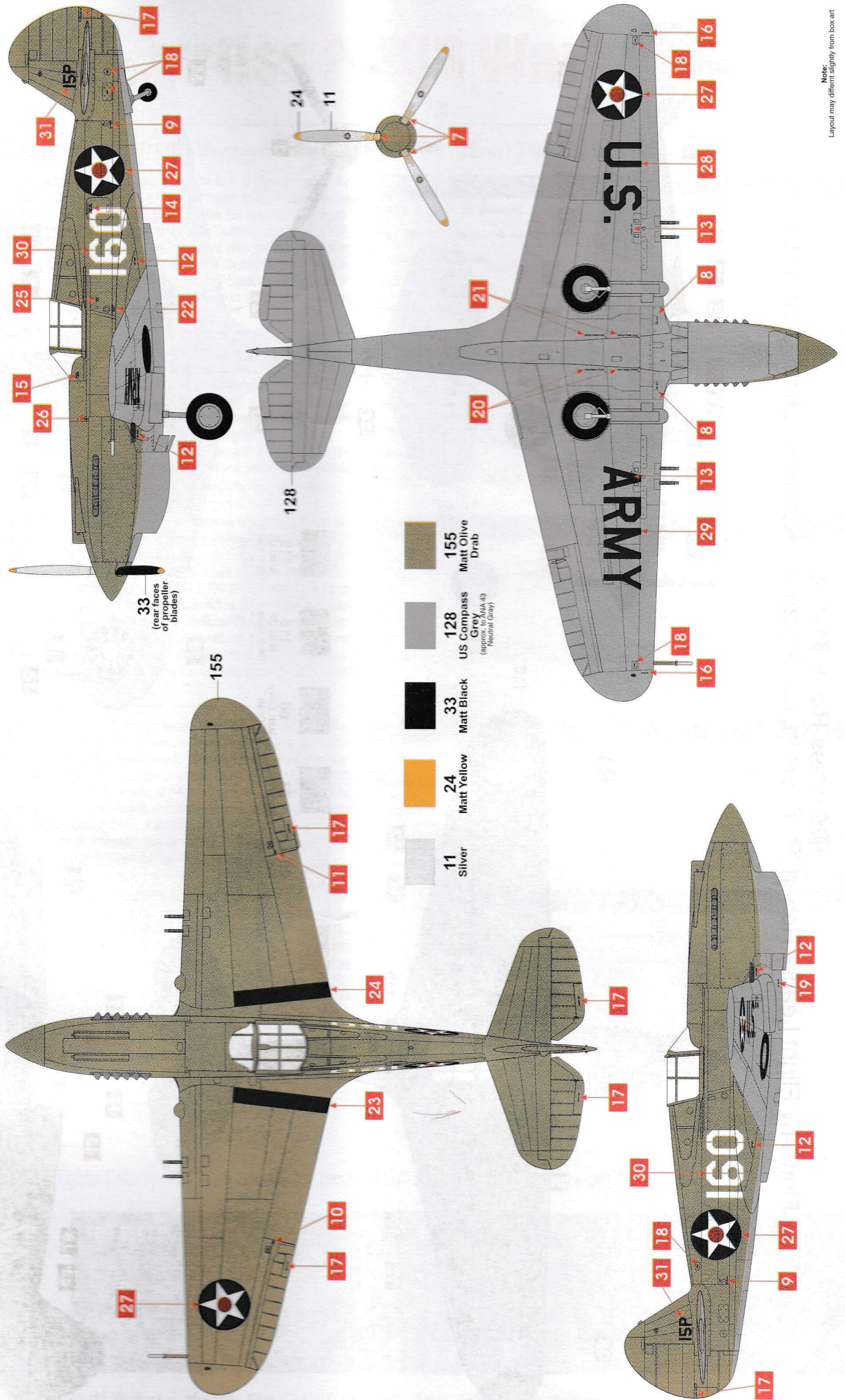

Note:  
Layout may differ slightly from box art.

**B Curtiss Hawk 81-A-2**  
 Flown by Flight Leader Robert 'R. T.' Smith, 3rd Squadron, Kunming, China, June 1942.

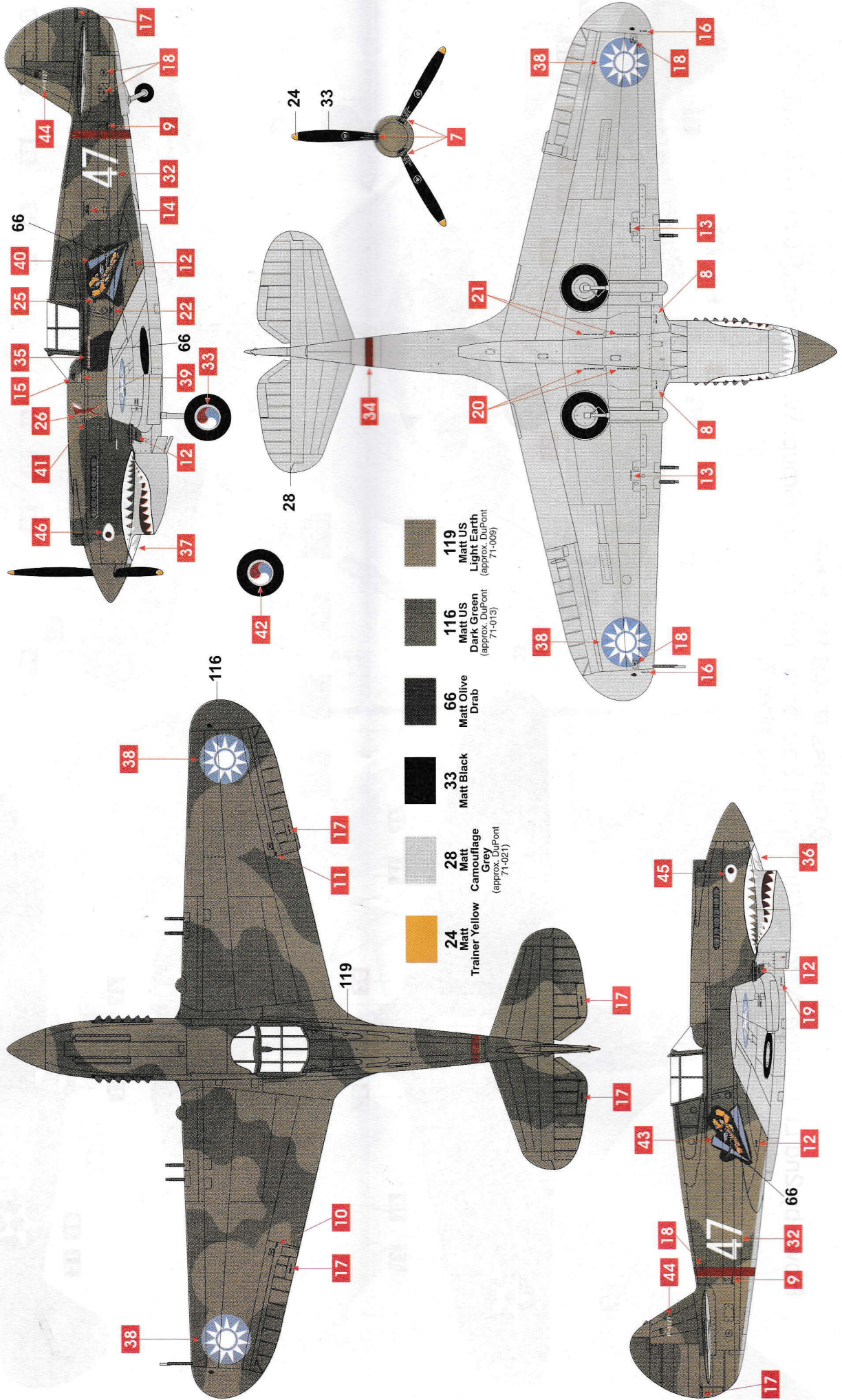

1 [Icons: 1, 2, 3, 4, 5, 6, 7, 8, 9, 10, 11, 12, 13, 14, 15, 16, 17, 18, 19, 20]

2 [Icons: 1, 2, 3, 4, 5, 6, 7, 8, 9, 10, 11, 12, 13, 14, 15, 16, 17, 18, 19, 20]

3 [Icons: 1, 2, 3, 4, 5, 6, 7, 8, 9, 10, 11, 12, 13, 14, 15, 16, 17, 18, 19, 20]

4 [Icons: 1, 2, 3, 4, 5, 6, 7, 8, 9, 10, 11, 12, 13, 14, 15, 16, 17, 18, 19, 20]

5 [Icons: 1, 2, 3, 4, 5, 6, 7, 8, 9, 10, 11, 12, 13, 14, 15, 16, 17, 18, 19, 20]

6 [Icons: 1, 2, 3, 4, 5, 6, 7, 8, 9, 10, 11, 12, 13, 14, 15, 16, 17, 18, 19, 20]

7 [Icons: 1, 2, 3, 4, 5, 6, 7, 8, 9, 10, 11, 12, 13, 14, 15, 16, 17, 18, 19, 20]

8 [Icons: 1, 2, 3, 4, 5, 6, 7, 8, 9, 10, 11, 12, 13, 14, 15, 16, 17, 18, 19, 20]

9 [Icons: 1, 2, 3, 4, 5, 6, 7, 8, 9, 10, 11, 12, 13, 14, 15, 16, 17, 18, 19, 20]

10 [Icons: 1, 2, 3, 4, 5, 6, 7, 8, 9, 10, 11, 12, 13, 14, 15, 16, 17, 18, 19, 20]

11 [Icons: 1, 2, 3, 4, 5, 6, 7, 8, 9, 10, 11, 12, 13, 14, 15, 16, 17, 18, 19, 20]

12 [Icons: 1, 2, 3, 4, 5, 6, 7, 8, 9, 10, 11, 12, 13, 14, 15, 16, 17, 18, 19, 20]

13 [Icons: 1, 2, 3, 4, 5, 6, 7, 8, 9, 10, 11, 12, 13, 14, 15, 16, 17, 18, 19, 20]

14 [Icons: 1, 2, 3, 4, 5, 6, 7, 8, 9, 10, 11, 12, 13, 14, 15, 16, 17, 18, 19, 20]

15 [Icons: 1, 2, 3, 4, 5, 6, 7, 8, 9, 10, 11, 12, 13, 14, 15, 16, 17, 18, 19, 20]

16 [Icons: 1, 2, 3, 4, 5, 6, 7, 8, 9, 10, 11, 12, 13, 14, 15, 16, 17, 18, 19, 20]

17 [Icons: 1, 2, 3, 4, 5, 6, 7, 8, 9, 10, 11, 12, 13, 14, 15, 16, 17, 18, 19, 20]

18 [Icons: 1, 2, 3, 4, 5, 6, 7, 8, 9, 10, 11, 12, 13, 14, 15, 16, 17, 18, 19, 20]

19 [Icons: 1, 2, 3, 4, 5, 6, 7, 8, 9, 10, 11, 12, 13, 14, 15, 16, 17, 18, 19, 20]

20 [Icons: 1, 2, 3, 4, 5, 6, 7, 8, 9, 10, 11, 12, 13, 14, 15, 16, 17, 18, 19, 20]

Common

21 [Icons: 1, 2, 3, 4, 5, 6, 7, 8, 9, 10, 11, 12, 13, 14, 15, 16, 17, 18, 19, 20]

22 [Icons: 1, 2, 3, 4, 5, 6, 7, 8, 9, 10, 11, 12, 13, 14, 15, 16, 17, 18, 19, 20]

23 [Icons: 1, 2, 3, 4, 5, 6, 7, 8, 9, 10, 11, 12, 13, 14, 15, 16, 17, 18, 19, 20]

24 [Icons: 1, 2, 3, 4, 5, 6, 7, 8, 9, 10, 11, 12, 13, 14, 15, 16, 17, 18, 19, 20]

25 [Icons: 1, 2, 3, 4, 5, 6, 7, 8, 9, 10, 11, 12, 13, 14, 15, 16, 17, 18, 19, 20]

26 [Icons: 1, 2, 3, 4, 5, 6, 7, 8, 9, 10, 11, 12, 13, 14, 15, 16, 17, 18, 19, 20]

**B** Third Squadron AVG

4747

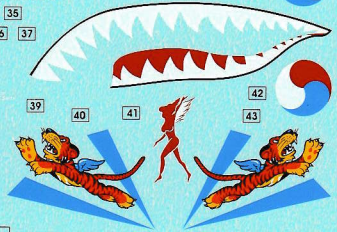
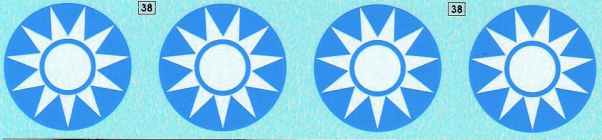

**A** 15th Pursuit Group

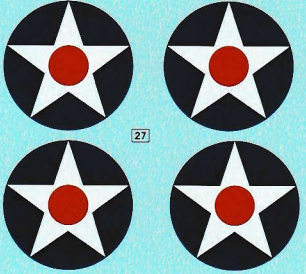

U.S. ARMY

160 160

15P 15P

A05130  
Curtiss P-40B