

MONOGRAM

KIT 5716

85571600200

B-52B WITH X-15 EXPERIMENTAL AIRCRAFT

Much has been written about the military uses of the mammoth B-52 Stratofortress jet bomber, but one of the most important applications for the huge plane came during the X-15 rocket plane program. A B-52 was converted to the role of drop-plane and along with an X-15 rocket powered craft with an extra pair of giant fuel tanks, history was made on October 3, 1967, the unofficial absolute speed record of 4,520 mph, which is more than six times the speed of sound was set. Your Monogram model features a highly detailed X-15 that can be wing mounted on the B-52, an optional landing gear up or down position and authentic military decals for both aircraft are also included.



* REPEAT SEVERAL TIMES



* REPEAT PROCEDURE



* OPTIONAL PARTS



* DECAL



* ASSEMBLY CAUTION



* CEMENT TOGETHER



* REMOVE AND THROW AWAY



* DO NOT CEMENT

* A REPETER PLUSIEURS FOIS * R P TEZ LE PROC D  * PI CES EN OPTION * DECAL COMANIE * ATTENTION D ASSEMBL E * A COLLER * A RETIRER ET JETER * NE PAS COLLER

READ THIS BEFORE YOU BEGIN

- * Study the assembly drawings.
- * Each plastic part is identified by a number.
- * In the assembly drawings, some parts will be marked by a star (★) to indicate chrome plated plastic.
- * For better paint and decal adhesion, wash the plastic parts in a mild detergent solution. Rinse and let air dry.
- * Check the fit of each piece before cementing in place.
- * Use only cement for polystyrene plastic.
- * Scrape plating and paint from areas to be cemented.
- * Allow paint to dry thoroughly before handling parts.
- * Any unused parts may be discarded.

DECAL APPLICATION INSTRUCTIONS

1. Cut desired decal from sheet.
2. Dip decal in water for a few seconds.
3. Place wet decal on paper towel.
4. Wait until decal is movable on paper backing.
5. Place decal in position on model, face up and slide backing away.
6. Press out air bubbles with a soft damp cloth.
7. Milkiness that may appear is for better decal adhesion and will dry clear. Wipe away any excess adhesive.
8. Do not touch decal until fully dry.
9. Allow the decals 48 hours to dry before applying clear coat.

NOTE: Decals are compatible with setting solutions or solvents.

LIRE CE QUI SUIT AVANT DE COMMENCER

- * Etudier les sch mas de montage.
- * Chaque pi ce en plastique est identifi e par un num ro.
- * Sur les sch mas de montage, certaines pi ces sont marqu es d'une  toile (★) pour indiquer qu'elles sont en plastique chrom .
- * Pour une meilleure prise de la peinture et des autocollants, laver les pi ces en plastique avec une solution d tergente peu concentr e. Les rincer et les laisser s cher   l'air.
- * V rifier que chaque pi ce s'ajuste bien avant de la coller en place.
- * N'utiliser que de la colle pour polystyr ne.
- * Gratter les parties   coller pour enlever le chrome et la peinture.
- * Laisser la peinture bien s cher avant de manipuler les pi ces.
- * Toute pi ce inutilis e peut  tre jet e.

DIRECTIVES D'APPLICATION DES AUTOCOLLANTS

1. D couper l'autocollant d sir  de la feuille.
2. Tremper l'autocollant dans de l'eau pendant quelques secondes.
3. Placer l'autocollant mouill  sur une serviette en papier.
4. Attendez que l'autocollant puisse  tre d plac  sur son support en papier.
5. Mettre l'autocollant en position sur le mod le face sur le dessus et faire glisser le support pour l'enlever.
6. Appuyer avec un chiffon doux humide pour  liminer les bulles d'air.
7. La substance laiteuse qui peut appara tre est destin e   am liorer l'adh sion de l'autocollant et devient incolore au s chage. Essuyer pour enlever tout exc dent d'adh sif.
8. Ne pas toucher l'autocollant tant qu'il n'est pas bien sec.
9. Laisser l'autocollant s cher pendant 48 heures avant d'appliquer une couche transparente.

REMARQUE: Les autocollants sont compatibles avec les solutions de fixage ou les solvants.

This paint guide is provided to complete this kit as shown on the box.

Ce guide de peintures est fourni pour reproduire le mod le r duit qui appar it sur la bo te.

Aluminum	Aluminum
Dark Aluminum	Aluminium fonc�
Semi Gloss Black	Noir satin�
Flat Black	Noir mat
Gloss Red	Rouge brillant
Flat White	Blanc mat
Silver	Argent
Gunmetal	Bronze
Light Gray	Gris clair
Zinc Chromate	Cromate de zinc
Orange	Orange

If you have any questions or comments, call our hotline at: **(800) 833-3570**
or, please write to:

Revell Inc Consumer Service Department, 1850 Howard Street Unit A, Elk Grove Village, Illinois 60007

Be sure to include the plan number (85571600200), part number, description, your return address and phone number.

Visit our website: www.revell.com

1

B-52B ASSEMBLY

? SEE STEP 4, IF YOU CHOOSE TO DISPLAY THE B52B WITH WHEELS UP

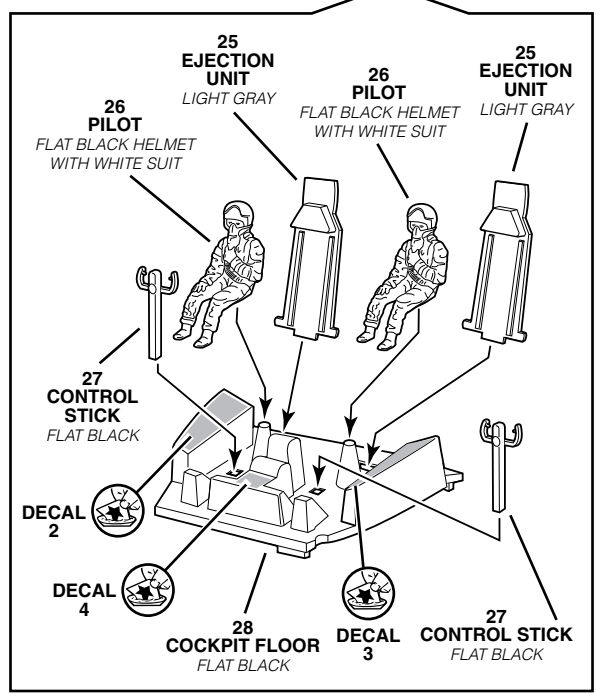
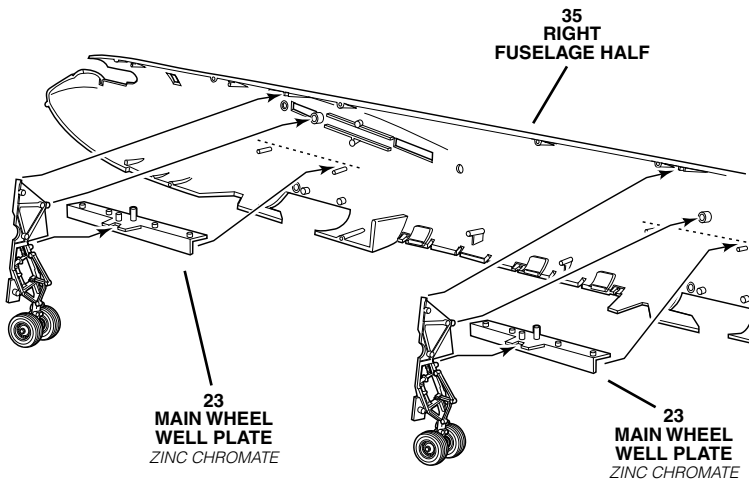
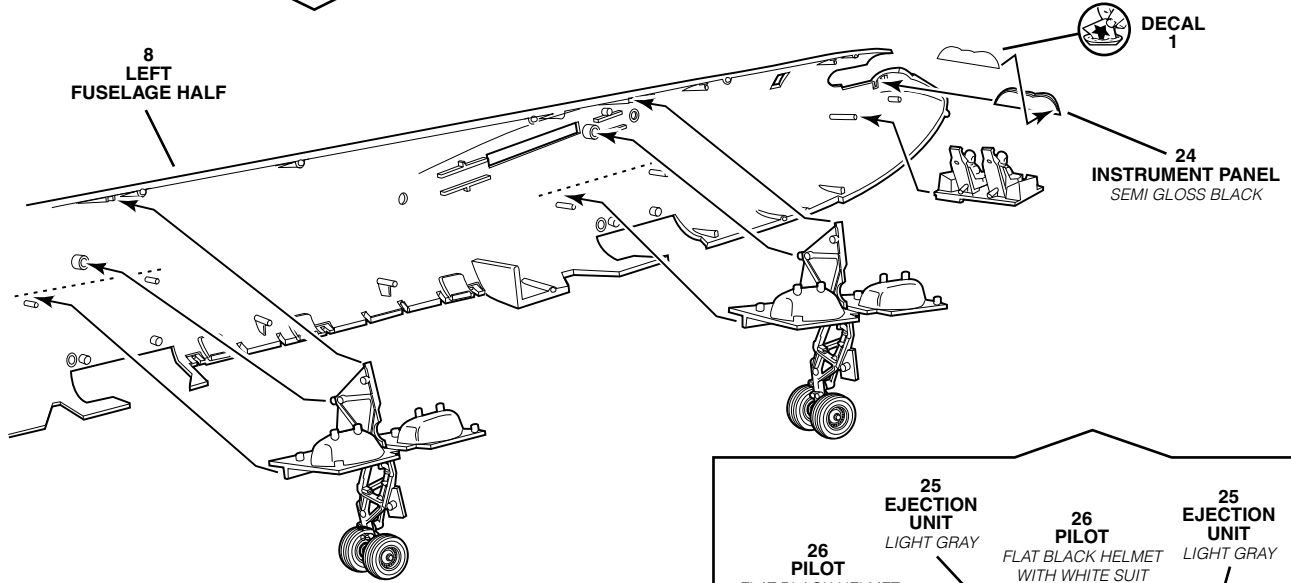
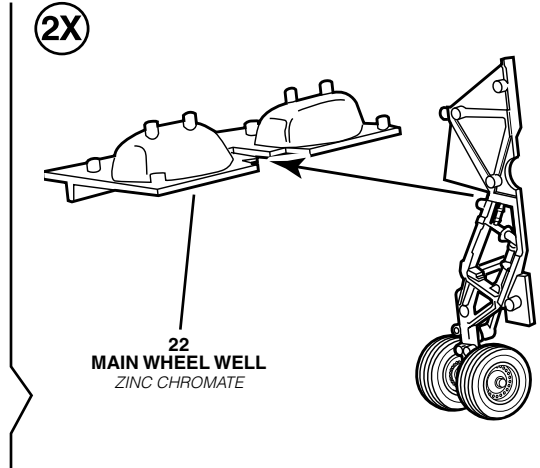
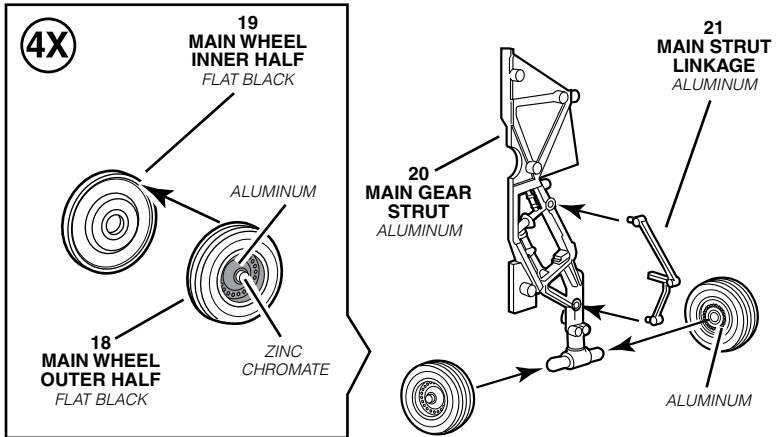

2

DOOR / WINDOW ASSEMBLY

RIGHT

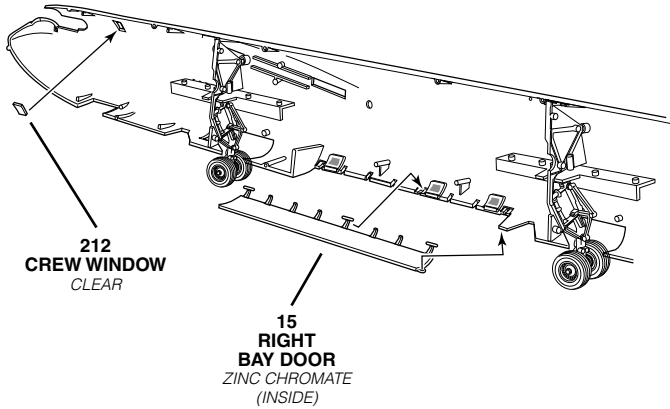

LEFT

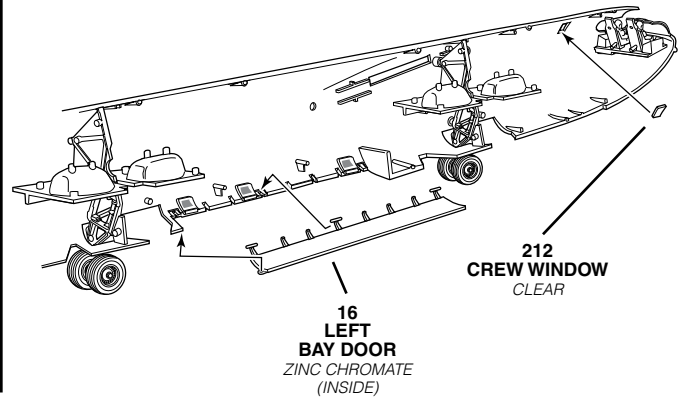

3

FUSELAGE ASSEMBLY

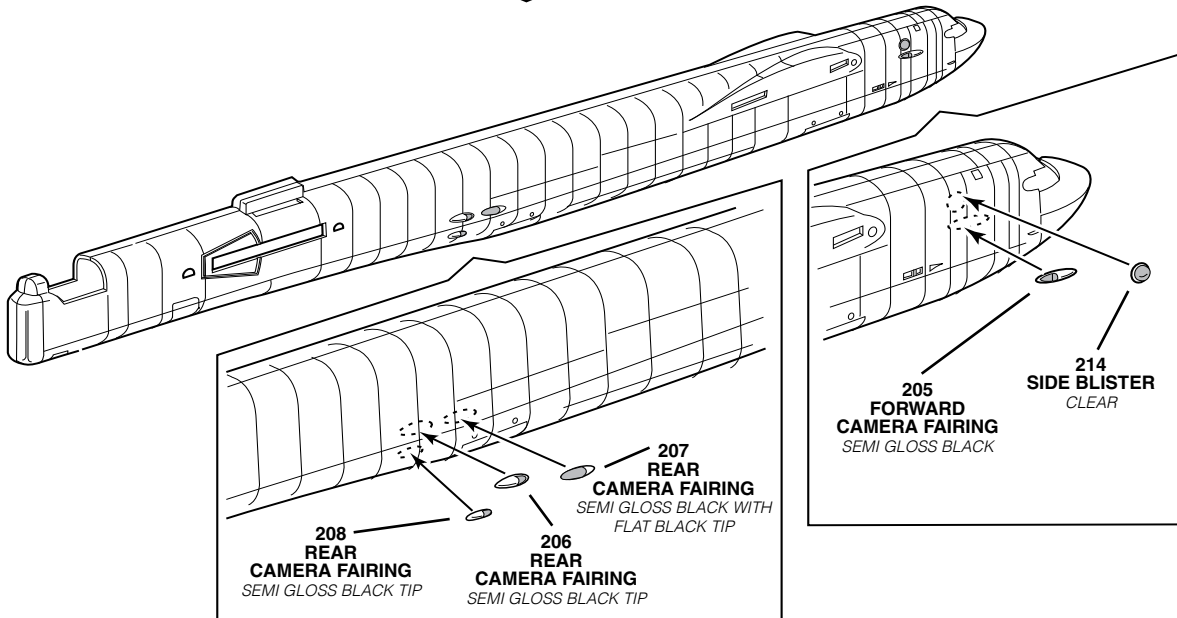
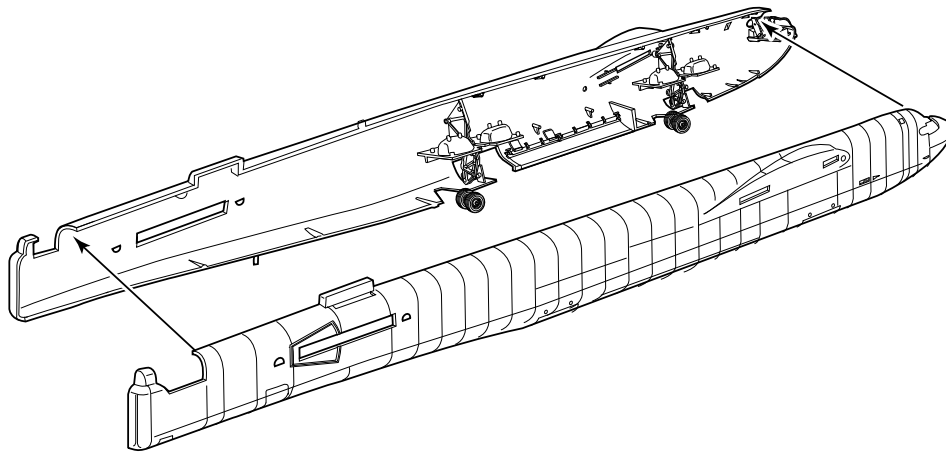

4

MAIN DOOR ASSEMBLY

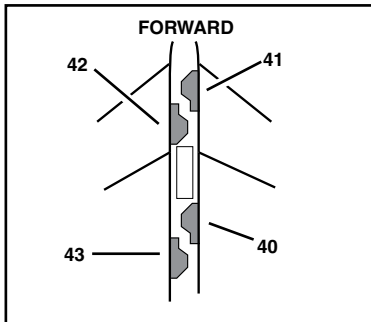

BOTTOM VIEW DOORS CLOSED

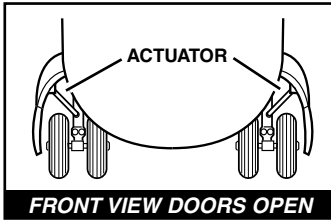

FRONT VIEW DOORS OPEN

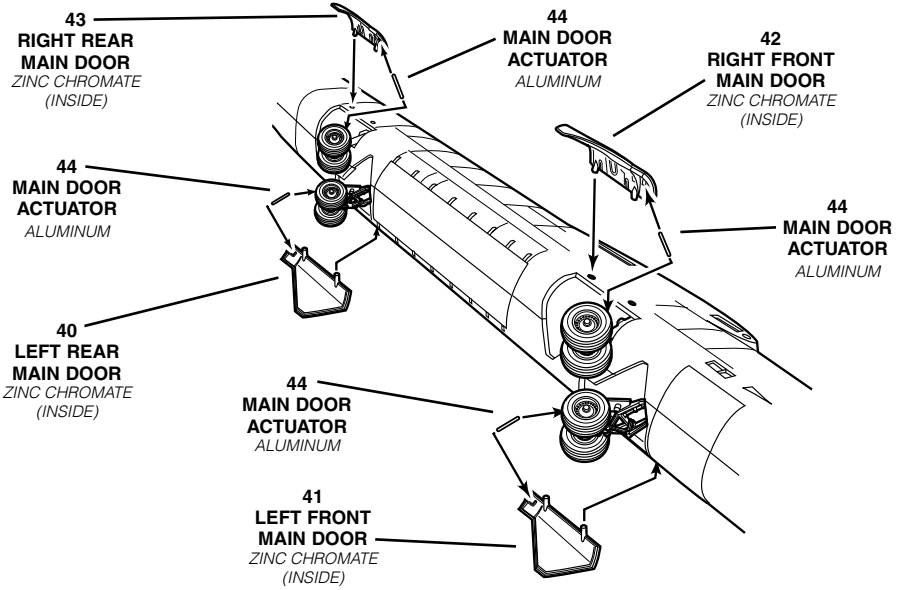

5

WING ASSEMBLY

SPOILER CAN BE GLUED IN THE OPEN OR CLOSED POSITION

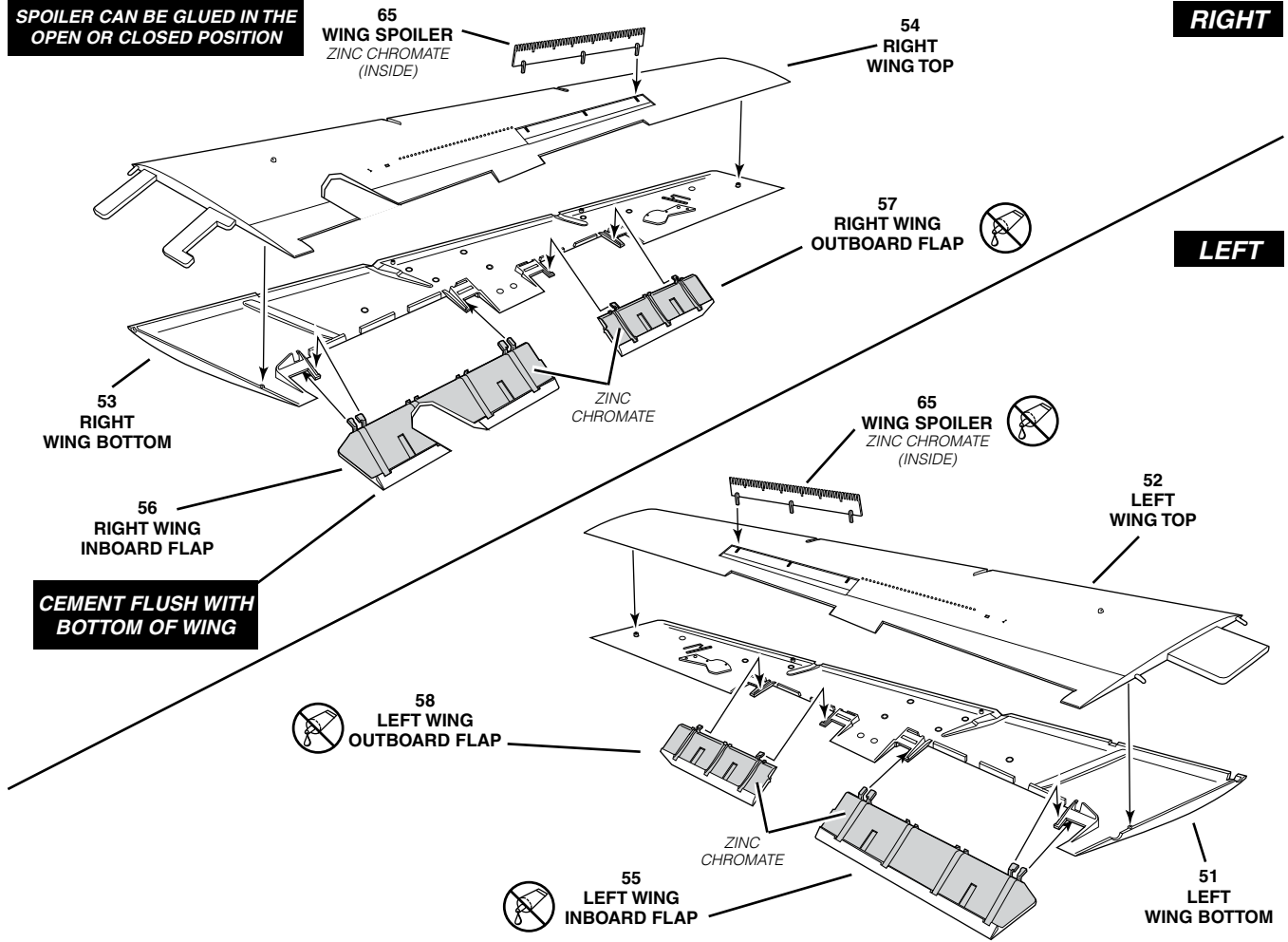

RIGHT

LEFT

CEMENT FLUSH WITH BOTTOM OF WING

6

WING TO FUSELAGE ASSEMBLY

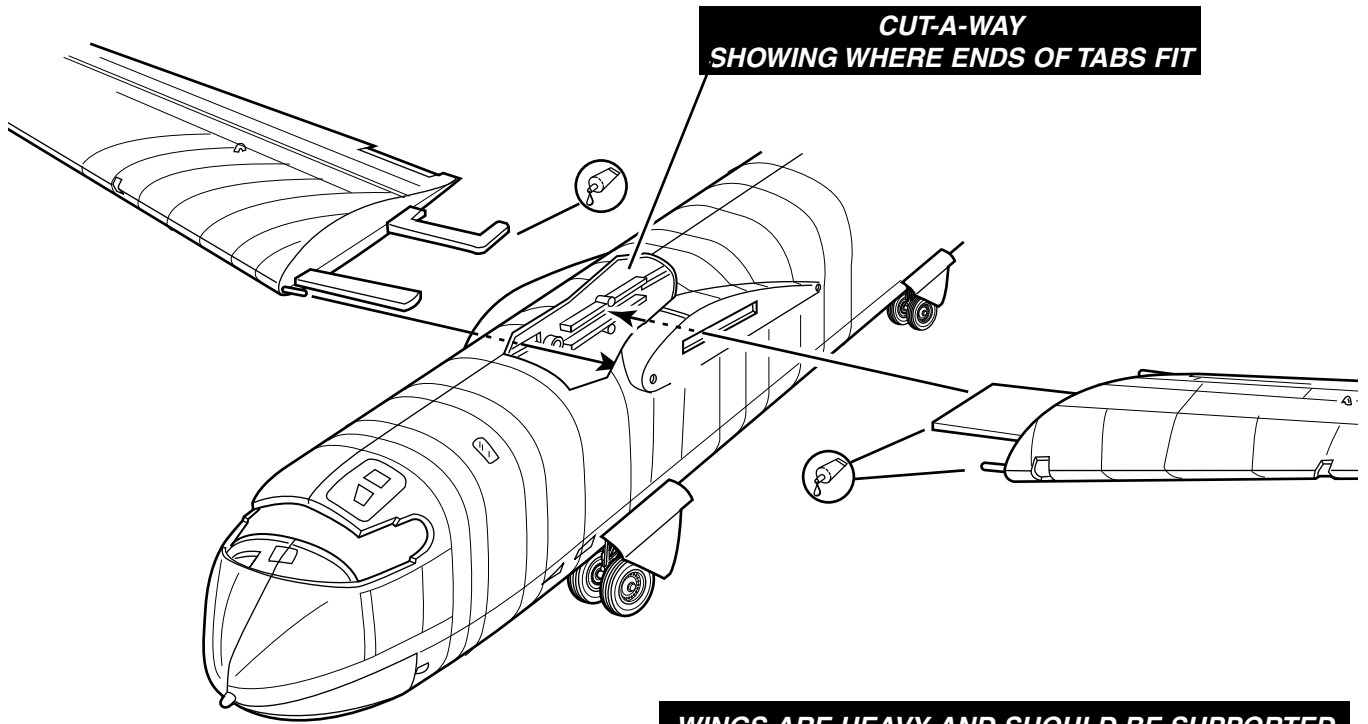

**CUT-A-WAY
SHOWING WHERE ENDS OF TABS FIT**

**WINGS ARE HEAVY AND SHOULD BE SUPPORTED
OVERNIGHT WHILE THE CEMENT DRIES**

7

OUTRIGGER ASSEMBLY

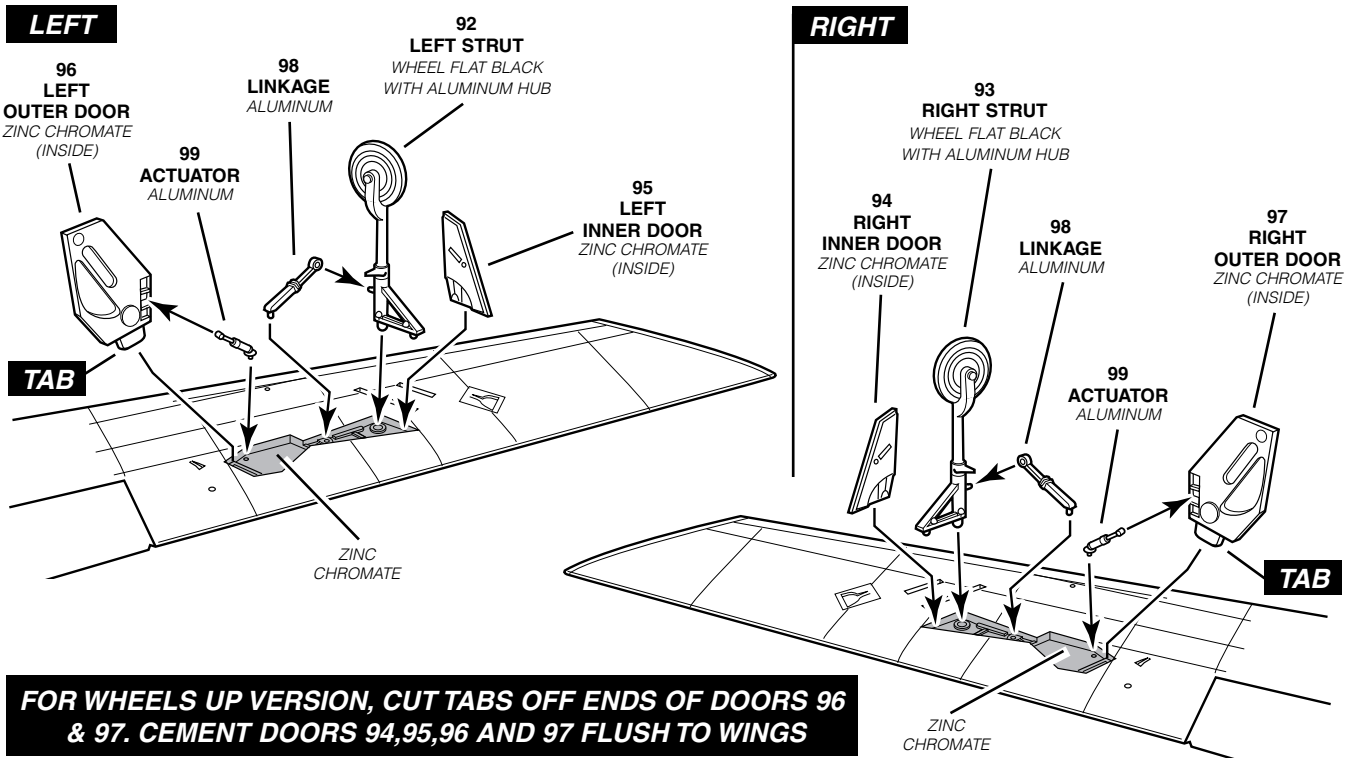

**FOR WHEELS UP VERSION, CUT TABS OFF ENDS OF DOORS 96
& 97. CEMENT DOORS 94,95,96 AND 97 FLUSH TO WINGS**

TAIL ASSEMBLY

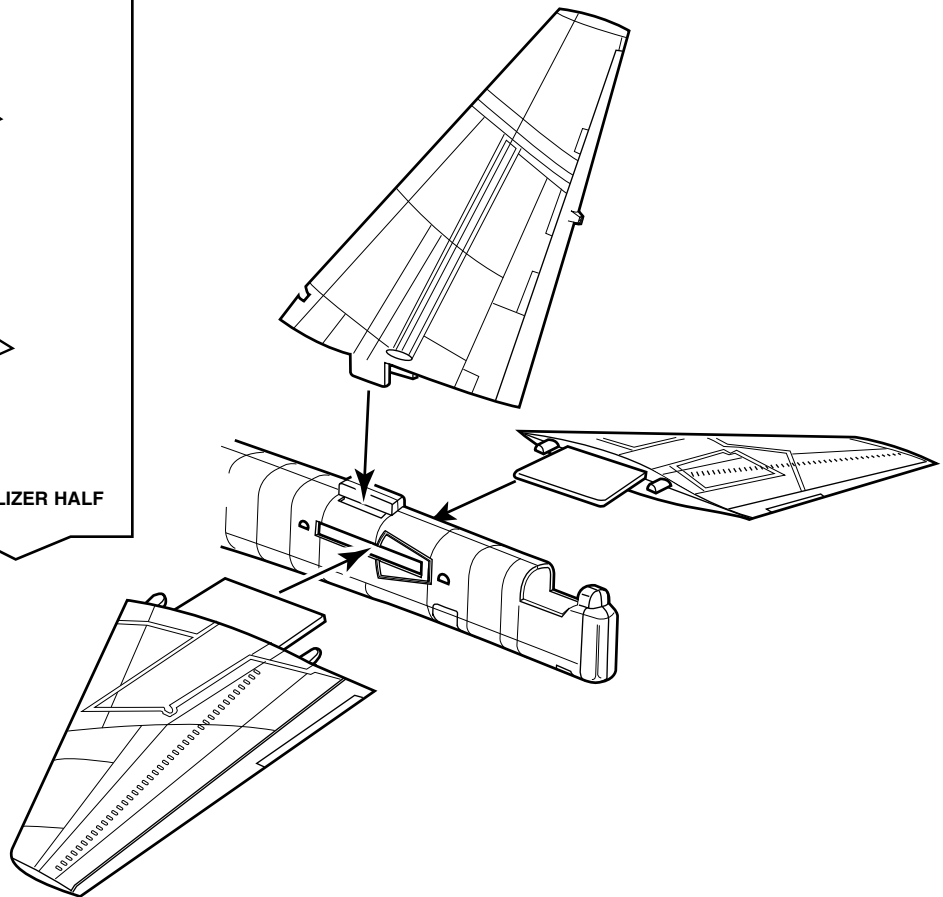
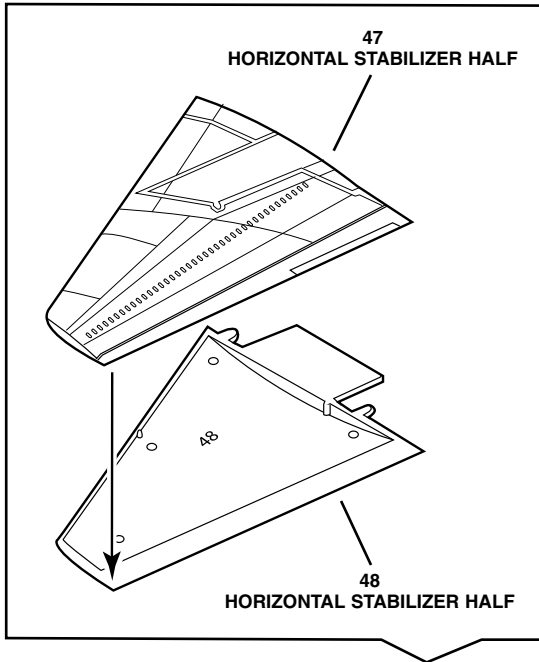
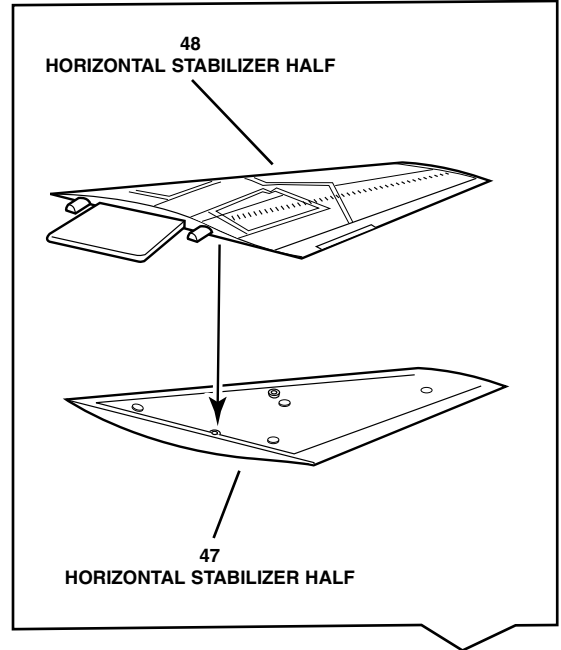
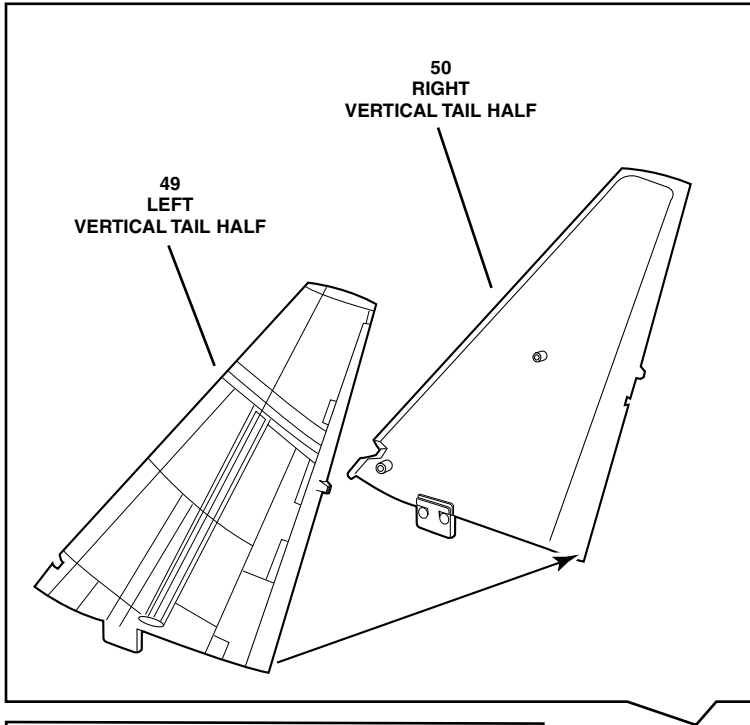

9

WINDSHIELD / CANOPY ASSEMBLY

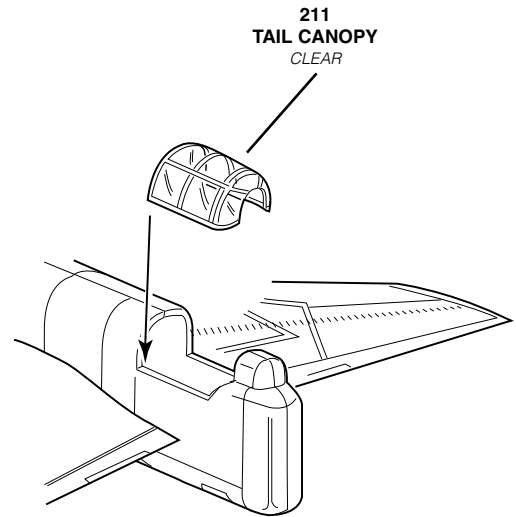
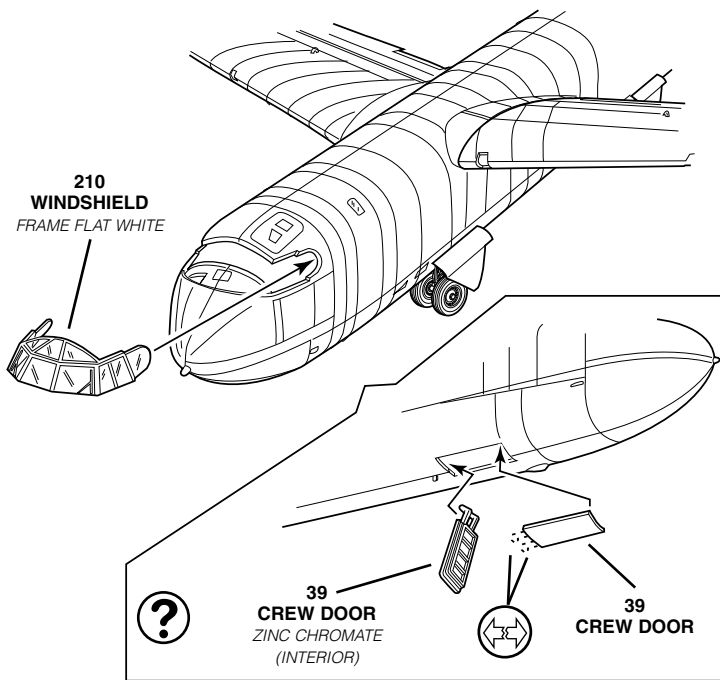

10

DISPLAY ENGINE ASSEMBLY



LEFT WING OUTBOARD NACELLE

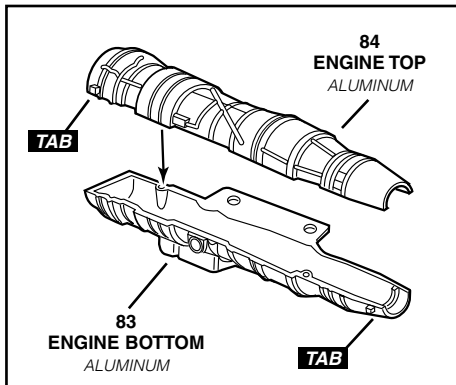

NOTE: NACELLE PROPS #87 CEMENTS TO PART #86 AND TO THE TABS ON THE ENGINE PARTS 83 & 84

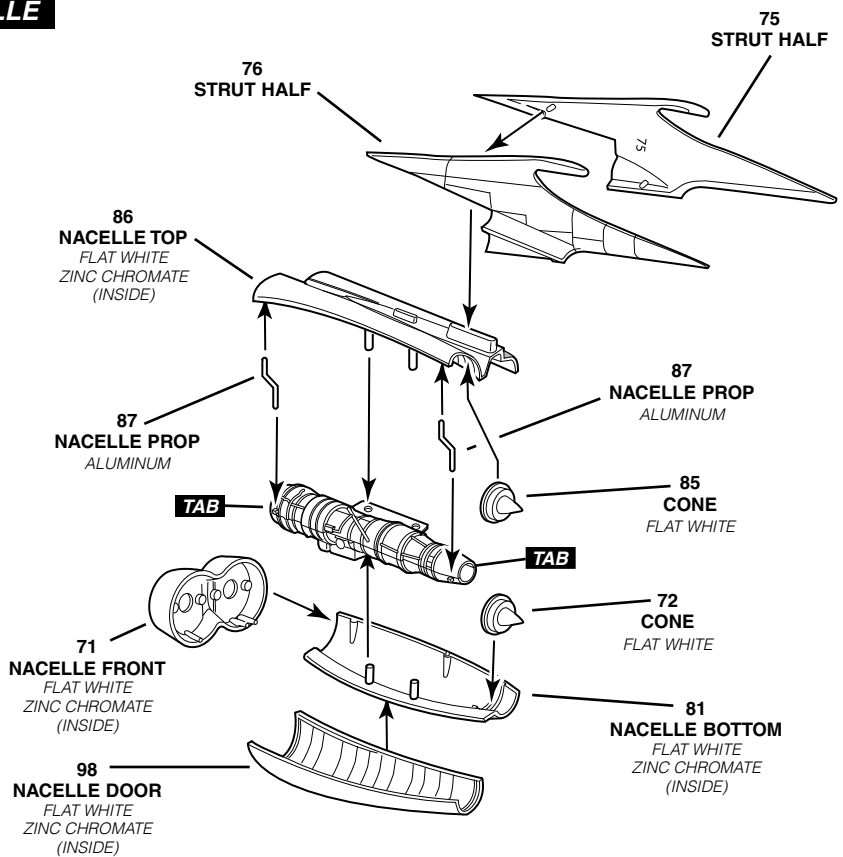
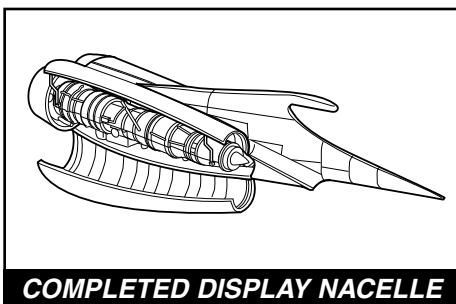

NACELLE ASSEMBLY

RIGHT INBOARD A

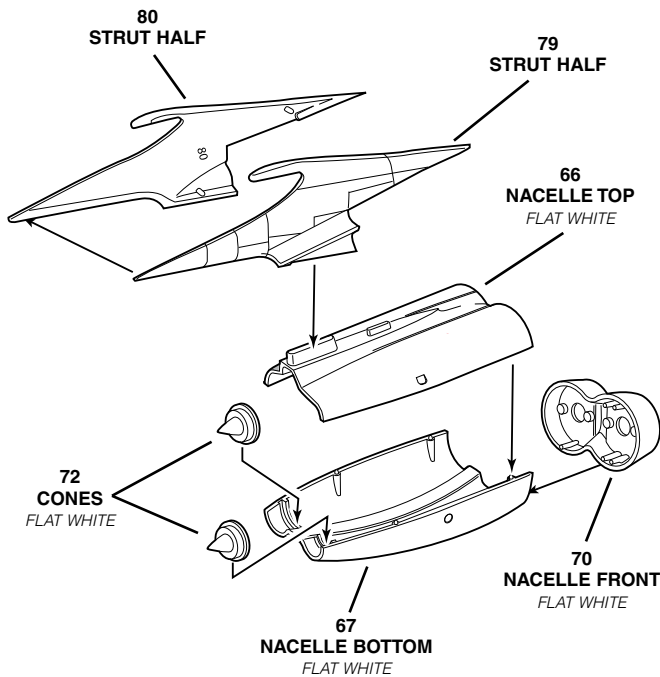

LEFT INBOARD C

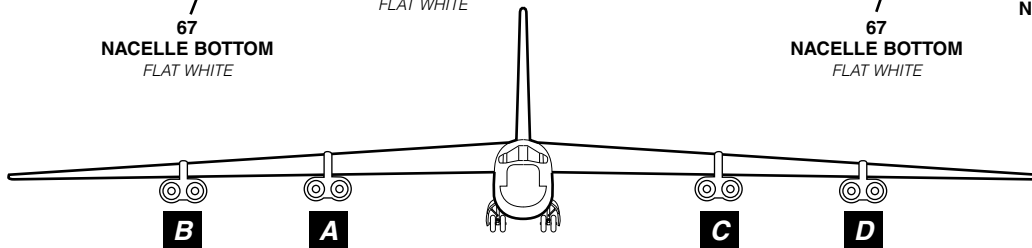
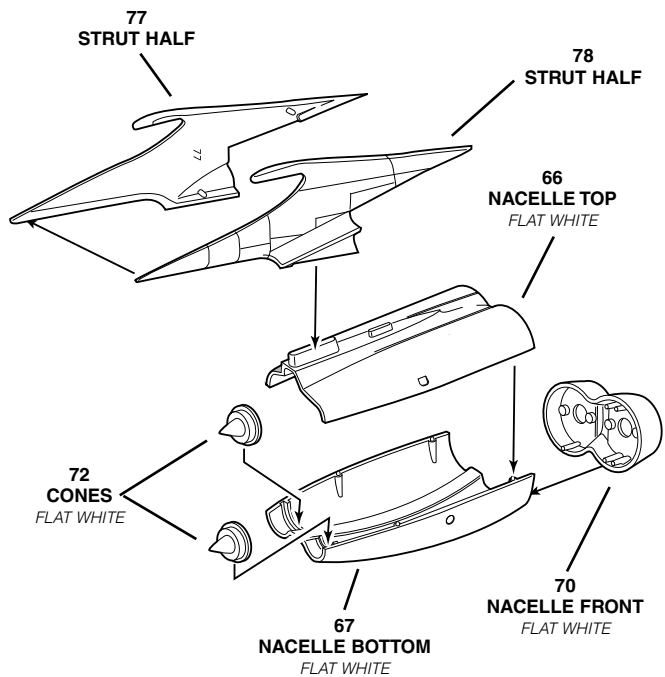

RIGHT OUTBOARD B

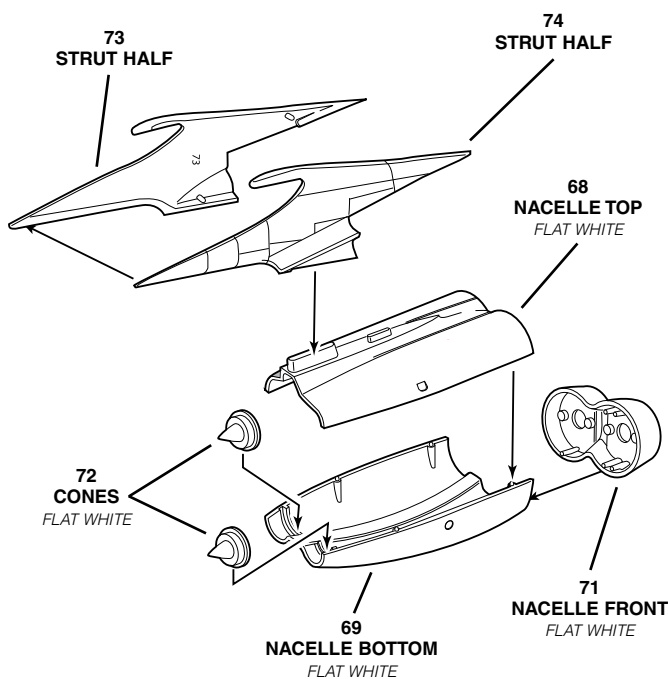

LEFT OUTBOARD D

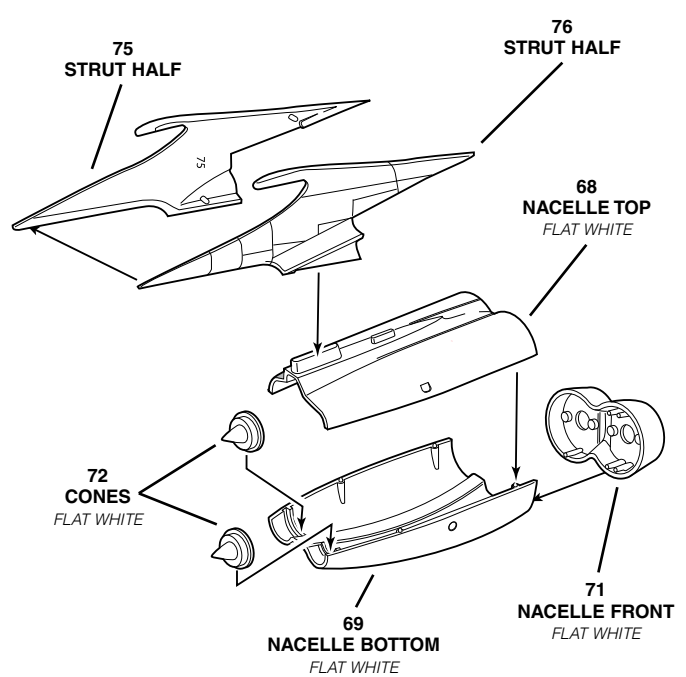

12

FINAL ASSEMBLY

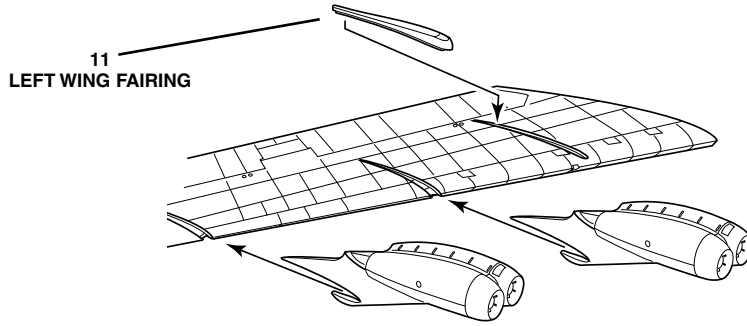

LEFT

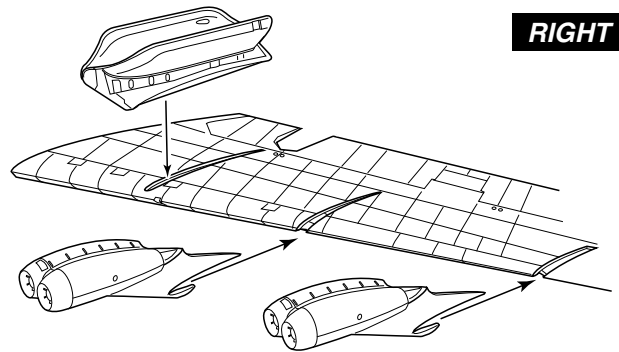
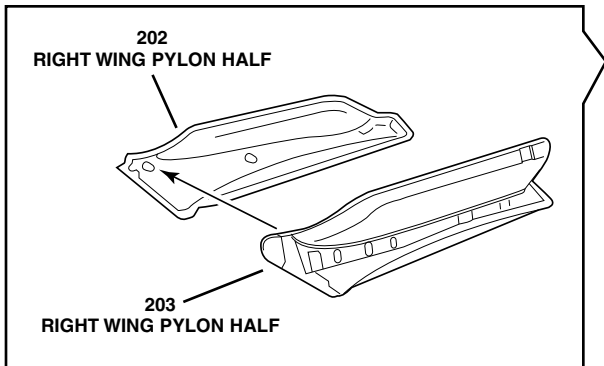

13

X-15 ASSEMBLY

VERSION A

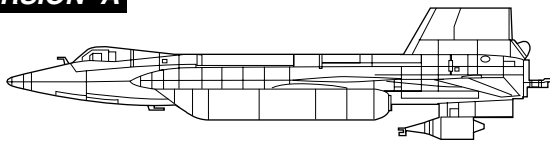

PAINT NOTE: ENTIRE AIRCRAFT WHITE, EXCEPT TANKS

VERSION B

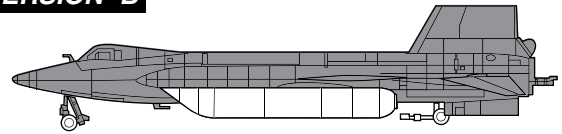

PAINT NOTE: ENTIRE AIRCRAFT BLACK, EXCEPT TANKS

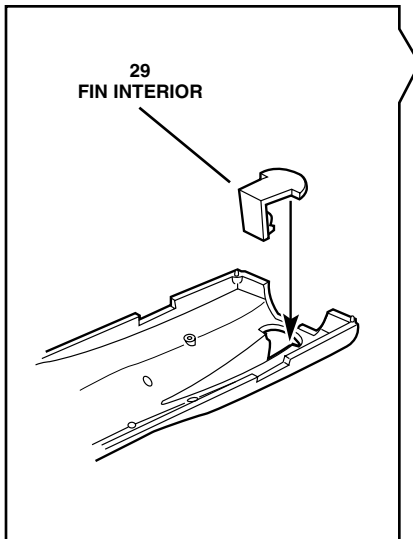

2
FUSELAGE
BOTTOM

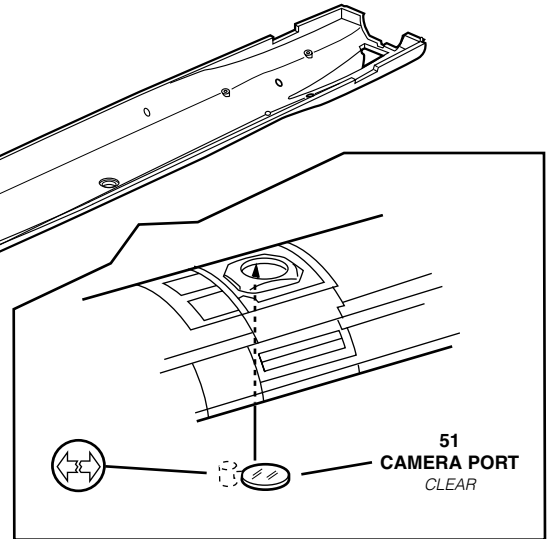

14

COCKPIT ASSEMBLY

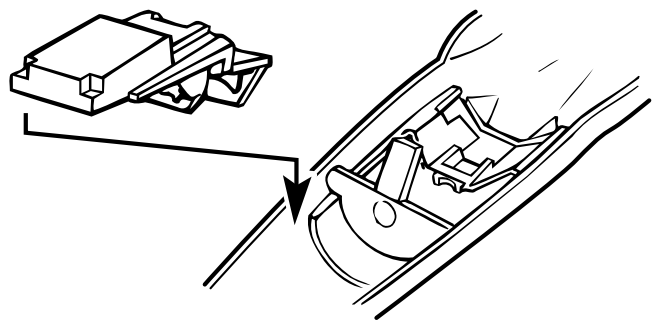
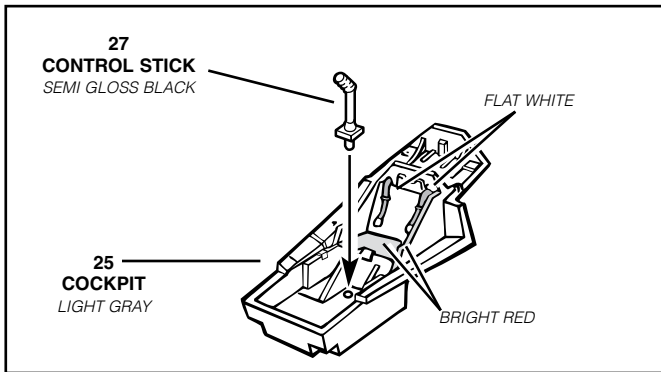
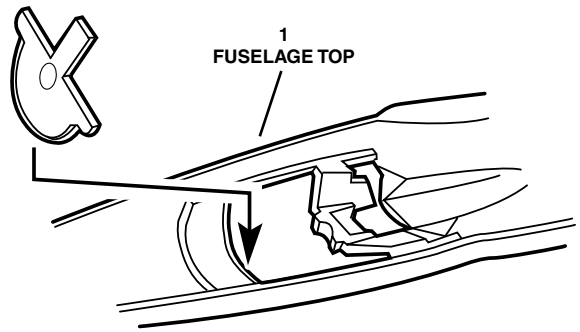
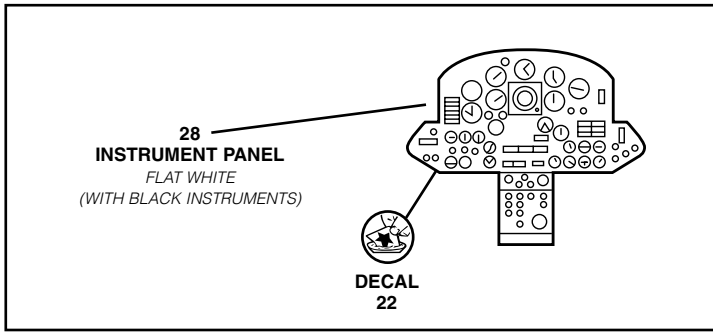

15

FUSELAGE ASSEMBLY

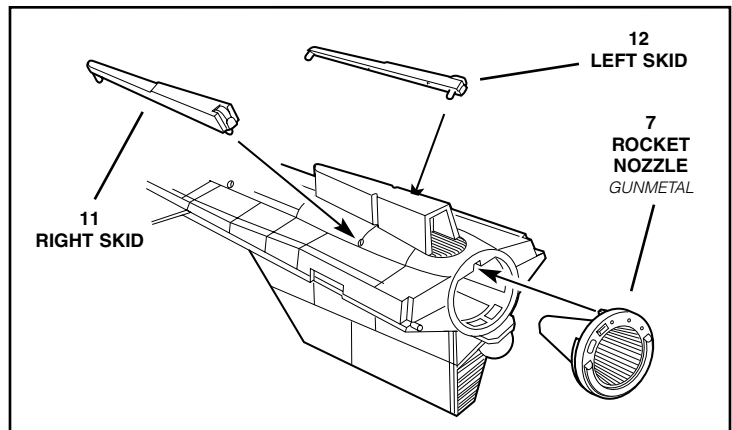
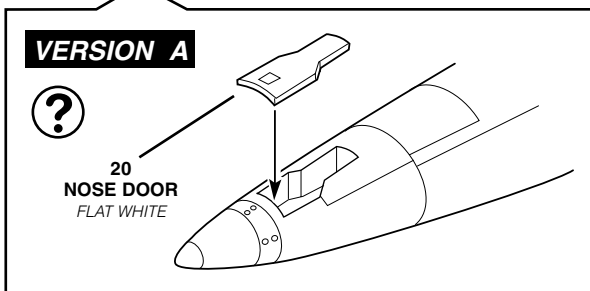
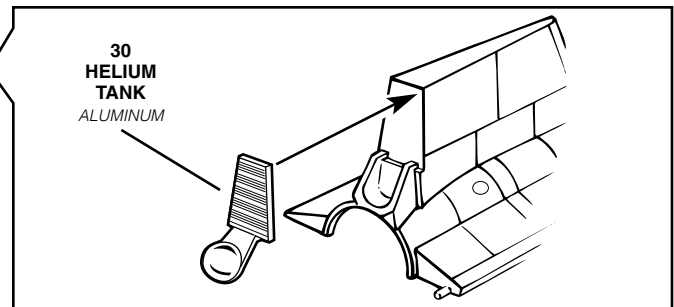
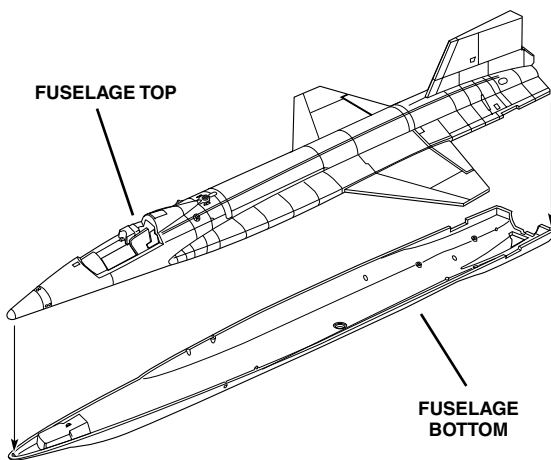

16

NOSE / DOLLY WHEEL ASSEMBLY



VERSION B OPTIONAL PARTS FOR WHEELS DOWN WHEN X-15 IS NOT ATTACHED TO B-52B

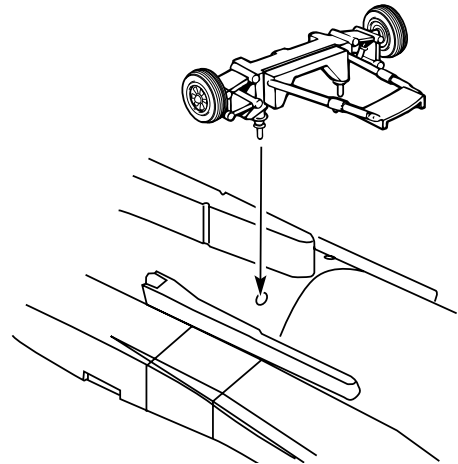
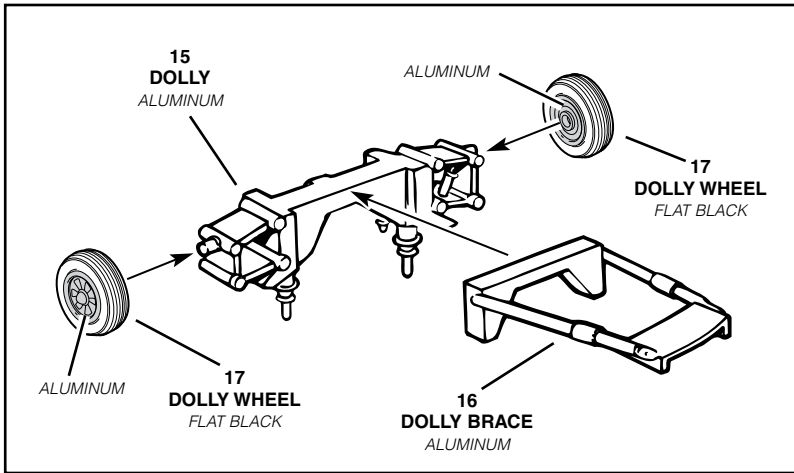
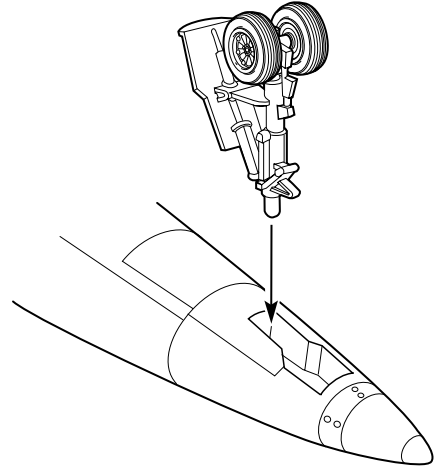
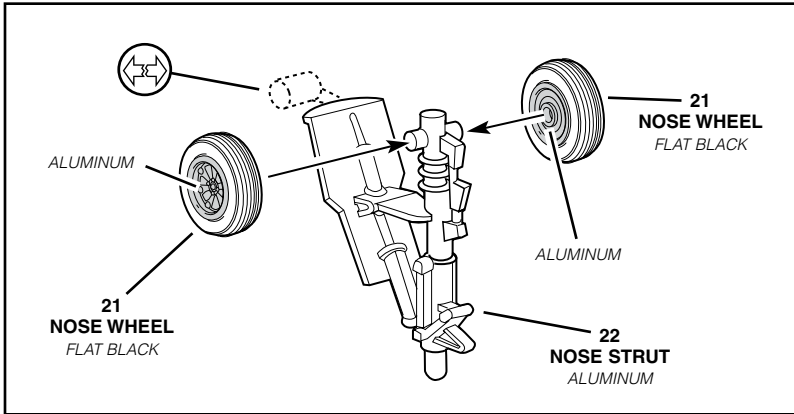

17

STABILIZER ASSEMBLY

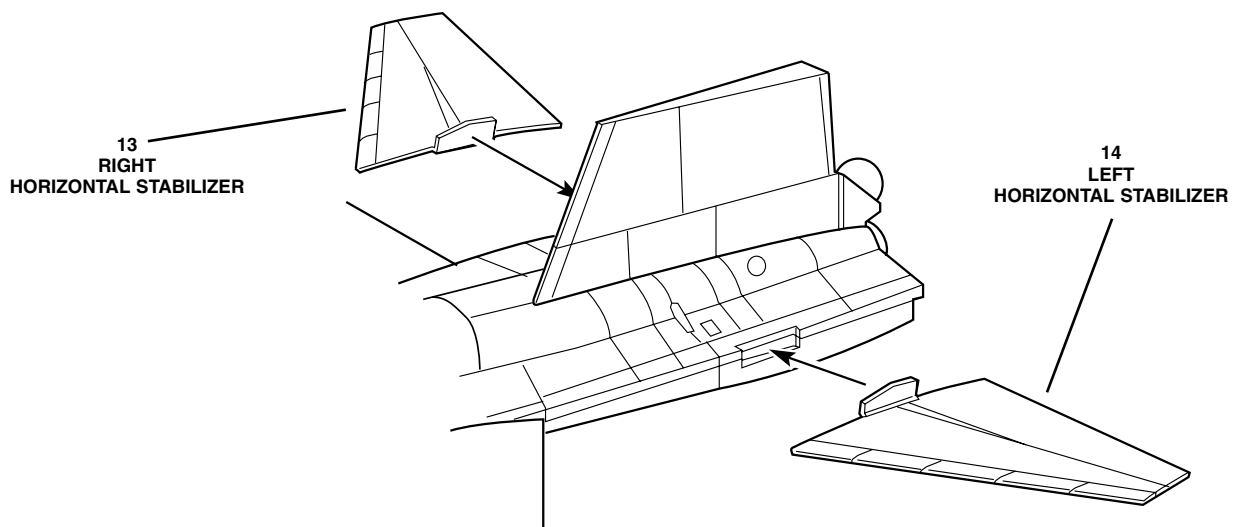

18

FUEL TANK ASSEMBLY

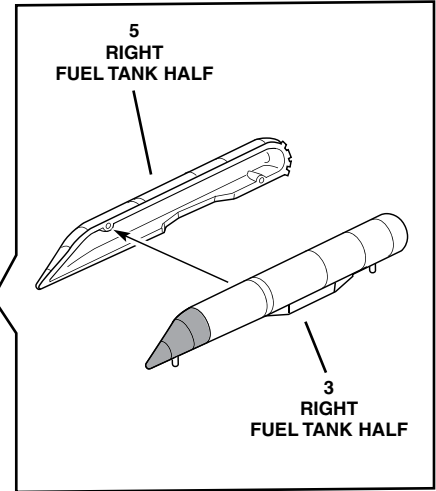
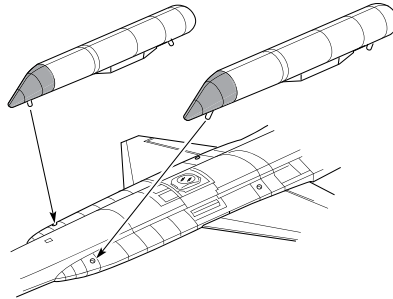
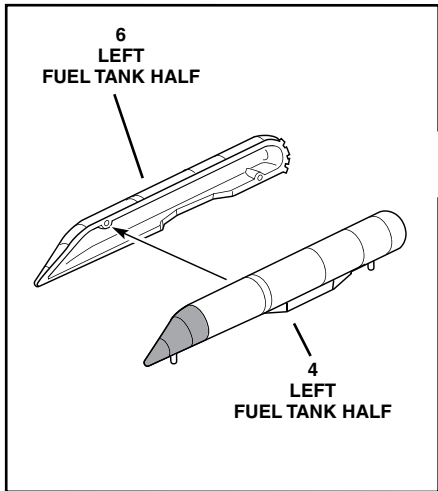

19

CANOPY / PITOT ASSEMBLY

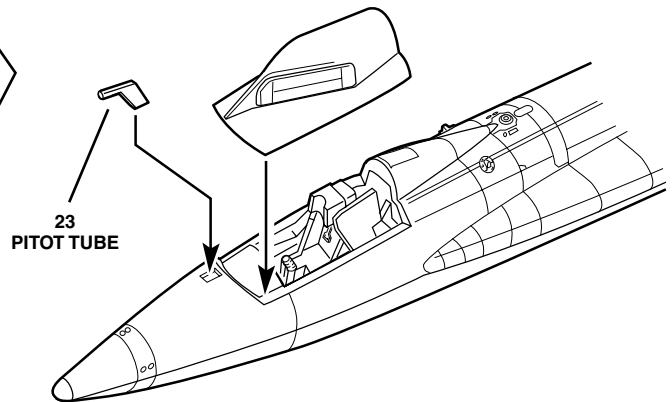
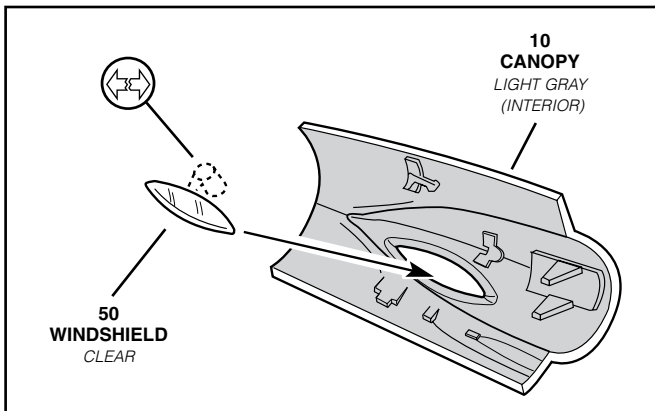

20

SENSOR / DUMP ASSEMBLY

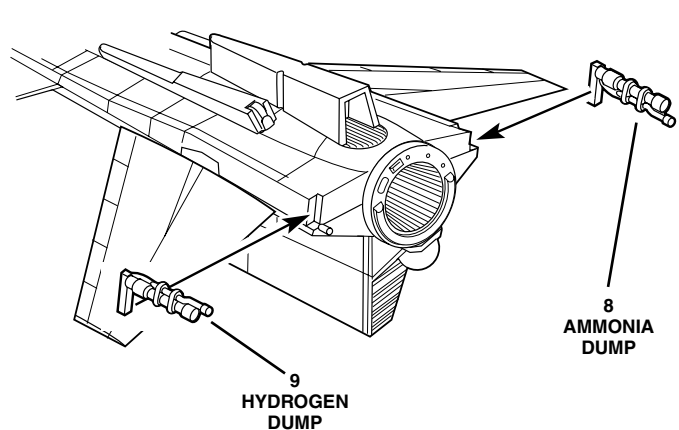
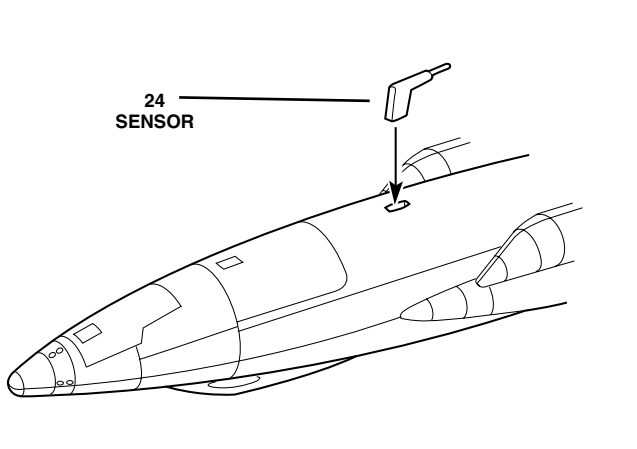

21

SCRAMJET ASSEMBLY



VERSION A

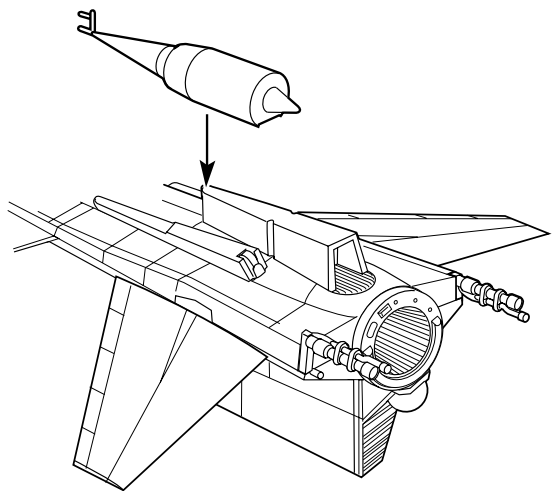
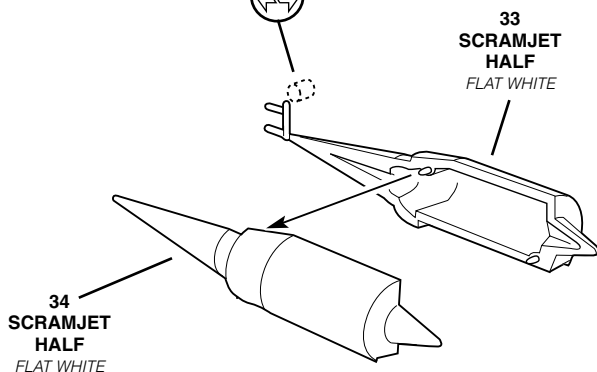

22

FINAL ASSEMBLY

COMPLETED X-15 TO PYLON ON RIGHT WING OF B-52

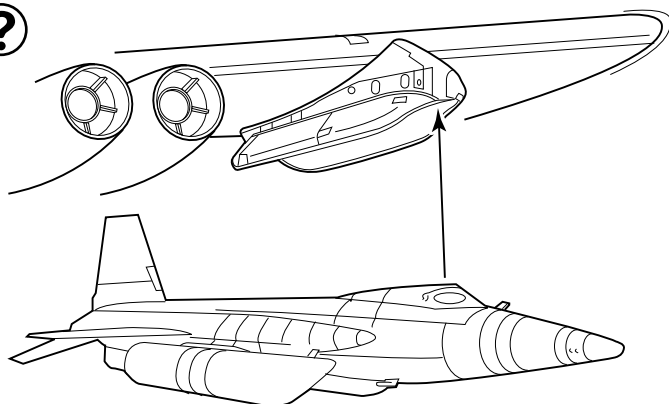

SEMI GLOSS BLACK

FLAT WHITE

FLAT WHITE

26
PILOT
SILVER SUIT

LIGHT GRAY

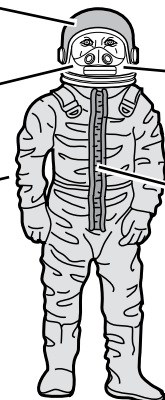

100
SUSPENSION
RING

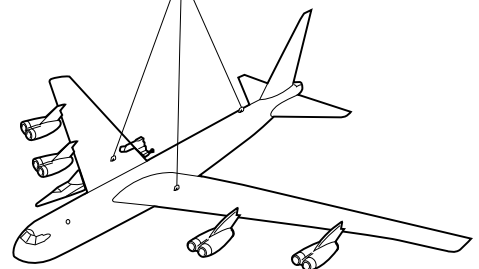

STRONG THREAD NOT SUPPLIED

31
STAND
SUPPORT

32
STAND
BASE

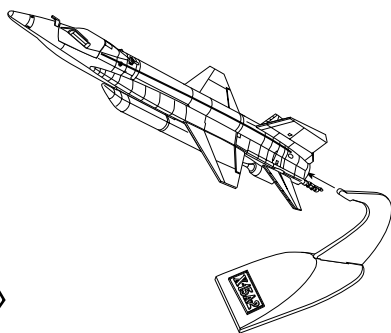
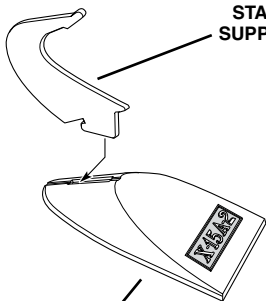



NASA NB-52B

PAINT COLORS

FB		FLAT BLACK
FW		FLAT WHITE
R		INSIGNIA RED FS 11136
A		ALUMINUM
GM		GUN METAL
FA		FLAT ALUMINUM
LG		LIGHT GRAY FS 36440
RT		RADOME TAN FS 33613

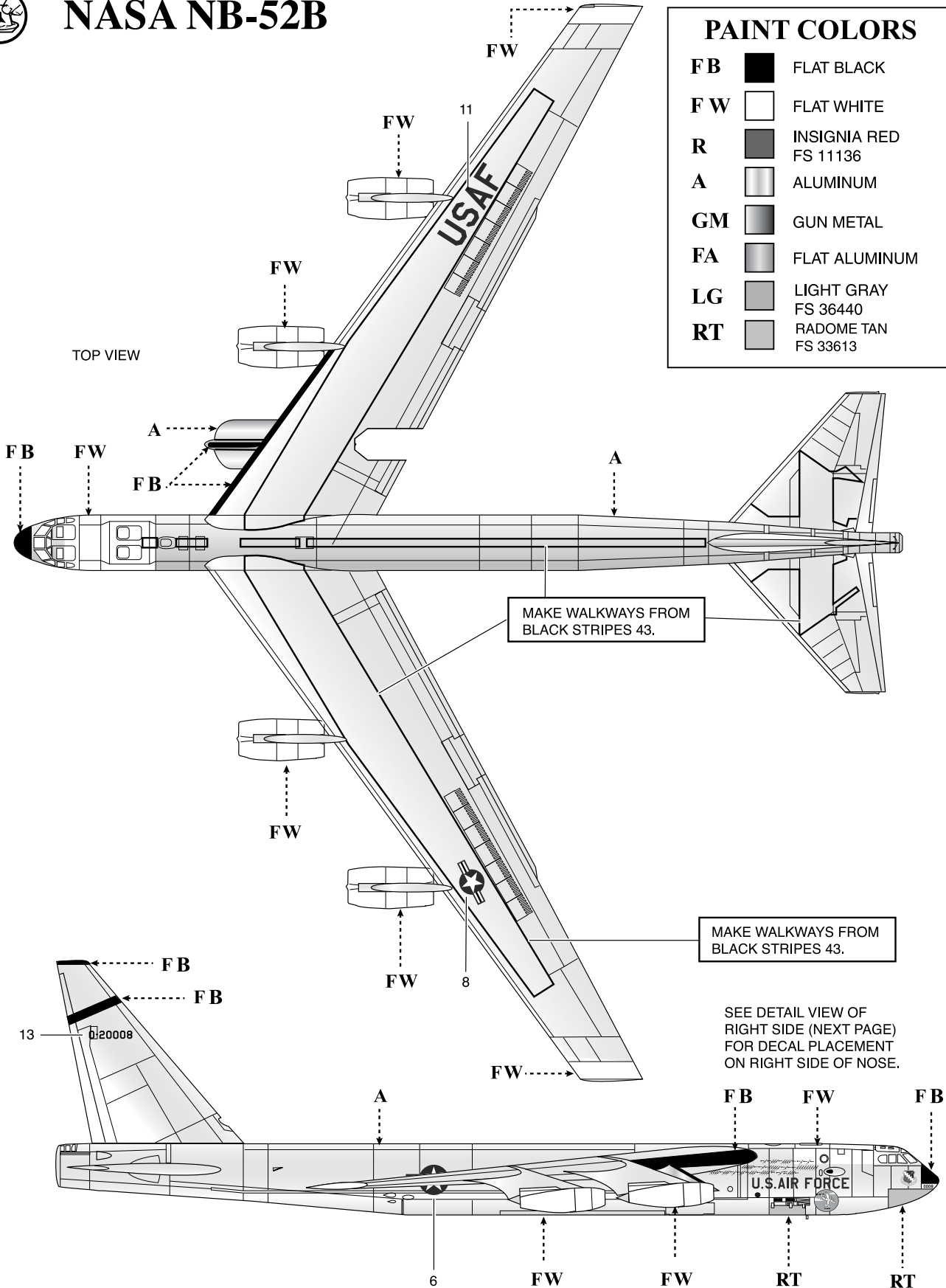

NASA NB-52B

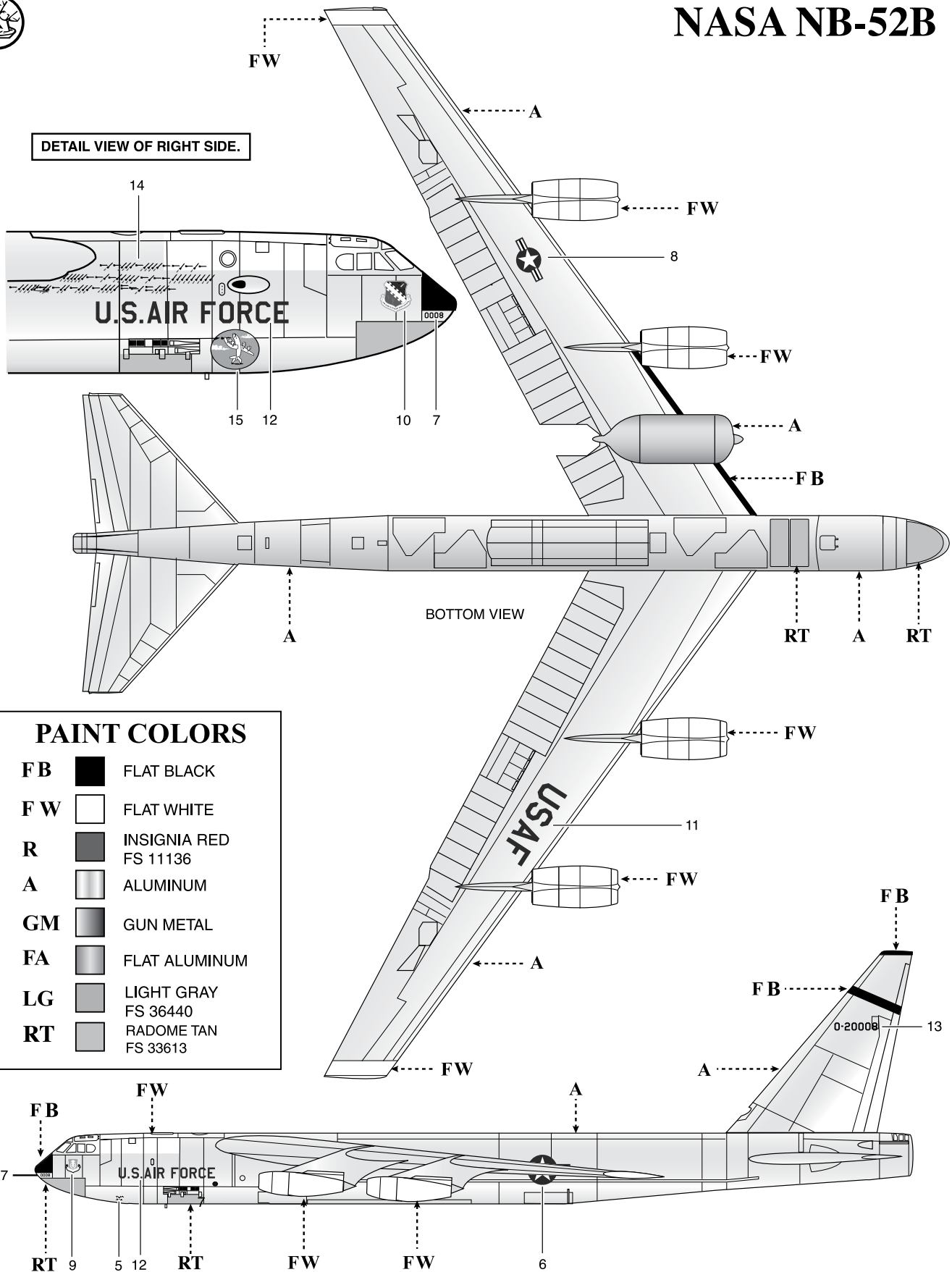

DETAIL VIEW OF RIGHT SIDE.

BOTTOM VIEW

PAINT COLORS

FB		FLAT BLACK
FW		FLAT WHITE
R		INSIGNIA RED FS 11136
A		ALUMINUM
GM		GUN METAL
FA		FLAT ALUMINUM
LG		LIGHT GRAY FS 36440
RT		RADOME TAN FS 33613



NASA X-15A/B

PAINT COLORS	
FB	FLAT BLACK
FW	FLAT WHITE
R	INSIGNIA RED FS 11136
A	ALUMINUM
GM	GUN METAL
FA	FLAT ALUMINUM
LG	LIGHT GRAY FS 36440
O	ORANGE

