

Wk Nr. 0353 at Comiso, September 1940. With crews trained by the Stuka school at Graz, Austria and based at Comiso from late August, the unit started operations against Malta during this period. The aircraft shown had German camouflage overpainted in the marking areas with Italian Verde Oliva Scuro 2 (Dark Green) or fresh Farbton 70. Except for the rudder cross only the spats were remarked with the emblem of 236 Sqa, 96 Gruppo. This was a diving crow believed inspired by that of St.G 1. A second (lower) bank of cloud was later added to this insignia which on this aircraft is also smaller than normal.

55 Serial on fin; 56 Rudder cross; 57 insignia on outboard of each spat.

Mix for Verde Oliva Scuro 2: HUMBROL HU.1 x 2 plus HUMBROL HX.1 x 1.

THIS SHEET ALLOWS THE FOLLOWING TO BE MODELLED:
 6G+KT of 6 Staffel/St.G 1 with sufficient items for +AT as an alternative.
 6G+FR of 7 Staffel/St.G 51 with sufficient items for +AR as an alternative.
 0353 of 236 Sq., 96 Gruppo, Italian Air Force.

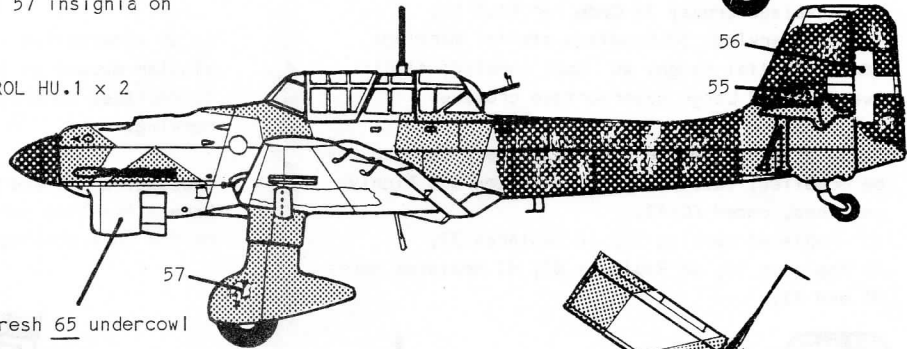
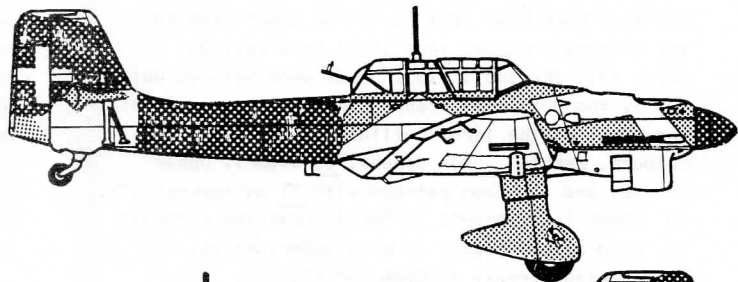

Location of Peil G.IV blister 6G+AT & 6G+KT

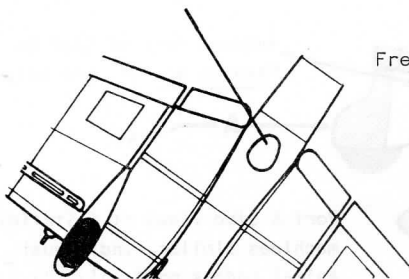

Fresh 65 undercowl

Uppersurface of 0353

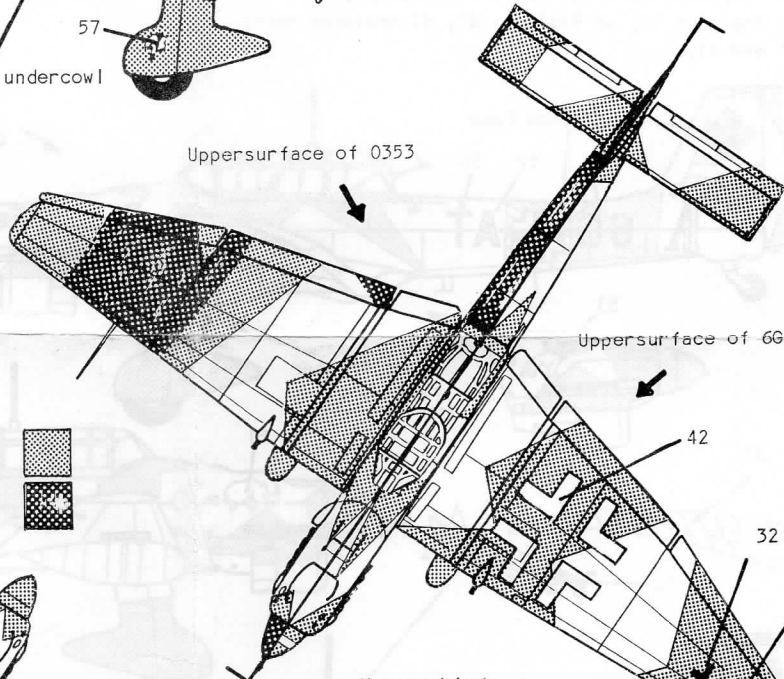

Uppersurface of 6G+FR

Underlined Numbers refer to camouflage shade references

43 (6G+AR only)

FARBTON 70
 VERDE OLIVA SCURO 2

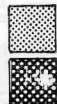

47

Uppersurface of 6G+AT; 6G+KT; 6G+AR.

PATTERN FOR STANDARD CAMOUFLAGE FARBTON 70 & 71

Narrow blade Jumo- Hamilton propellor fitted to +FR & +AR.

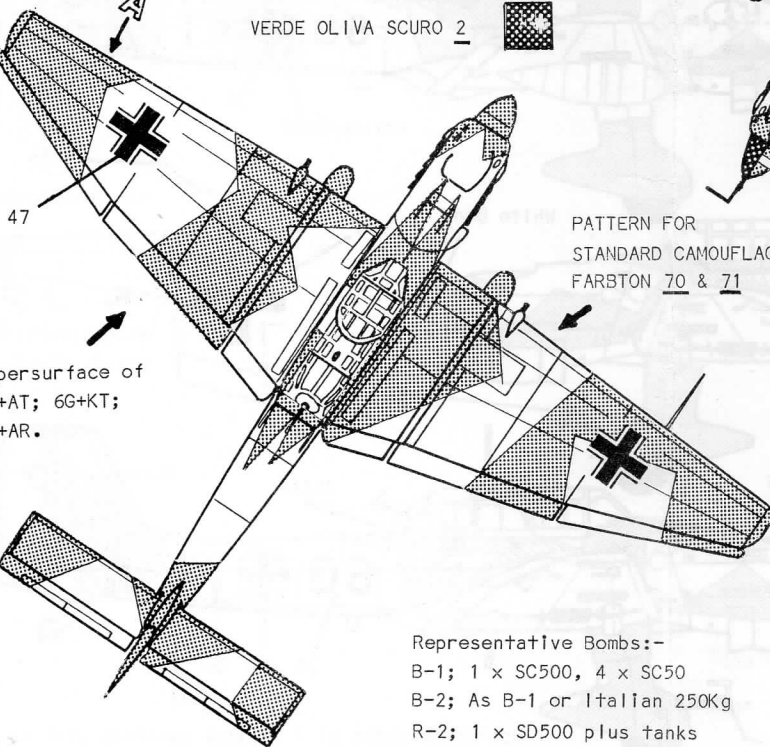

Representative Bombs:-
 B-1; 1 x SC500, 4 x SC50
 B-2; As B-1 or Italian 250Kg
 R-2; 1 x SD500 plus tanks

E.D. Models

JUNKERS Ju 87 B & R
 SHEET C7
 Early Stuka's

E.D. MODELS., 64 STRATFORD ROAD,
 SHIRLEY, SOLIHULL B90 3LP,
 ENGLAND. Tel: 021-744-7488

Research by Les Whitehouse.

6G+FR of this staffel in Germany late 1939 shows an interesting interpretation of instructions to increase size and visibility of crosses following lessons of the Polish campaign. Extra large white outlines have been applied to the upper wing but the original crosses were still retained. By early 1940 the small tip crosses were painted out and by the Battle of France wartime standard items had replaced the large outlines. Colours, Farbton 70/71 uppers, 65 unders. Upper crosses and fuselage patched with 71 as appropriate. 59 Underwing crosses; 31 Small upperwing crosses; 32 Wing uppersurface; 33 Wing undersurface; 34 Fuselage cross; 35 Code for St.G 51; 36 A/C Marking; 37 Fuselage staffel marking; 38/39 Staffel badge; 40 Spat marking; 41 Fin Swastika; 42 Large uppersurface crosses.

As an alternative the Staffel leaders machine can be modelled. This was crisply marked and highly polished, coded 6G+AR.

43 Replaces marking 32; 44 Replaces 33; 45 Replaces 36; 46 Replaces 40; 47 Replaces marks 31 and 42.

6G+KT operating on the Eastern Front during the Spring of 1942. 6 Staffel was formed from 9/St.G 51 and used the old codes and unit badge. However, during this period the 'Devil' badge was abandoned for individual animals painted on each machine, the above machine having a 'Hippo'.

Painted in the standard 70/71 with 65 unders the unit codes are smaller and higher up the fuselage than usual.

30 Underwing crosses; 34 Fuselage cross; 41 Fin Swastika; 47 Uppersurface cross; 48 Code St.G 1; 49 A/C marking; 50 Fuselage Staffel code; 51 A/C individual badge.

As an alternative the Staffel leaders machine was similar except as follows:

52 Replaces marking 49; 53 Replaces 51; 54 Spat marking.

These aircraft are Peil G.IV equipped and do not have a trailing aerial. Items 51 or 53 are marked on the port cowling only.

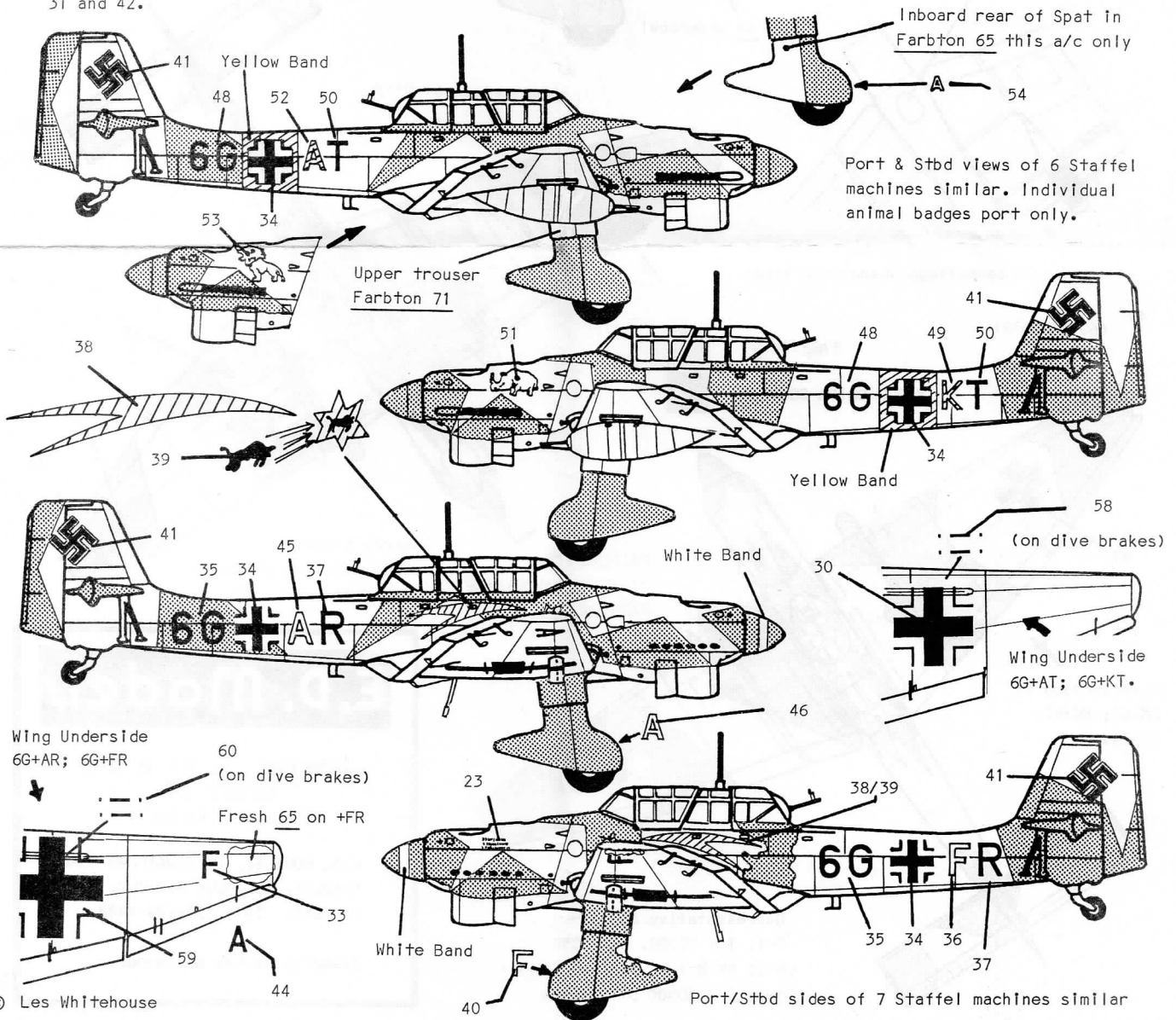

PORT ONLY:
4,12,17,22,
23.
STBD ONLY:
13.
OTHERS BOTH
BUT 11 IN
SEPARATE
POSITIONS

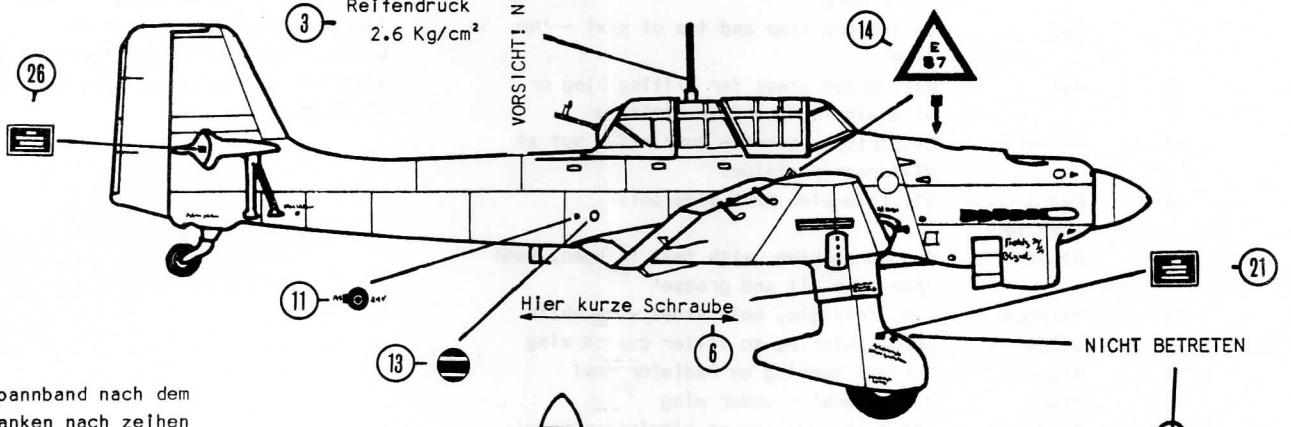
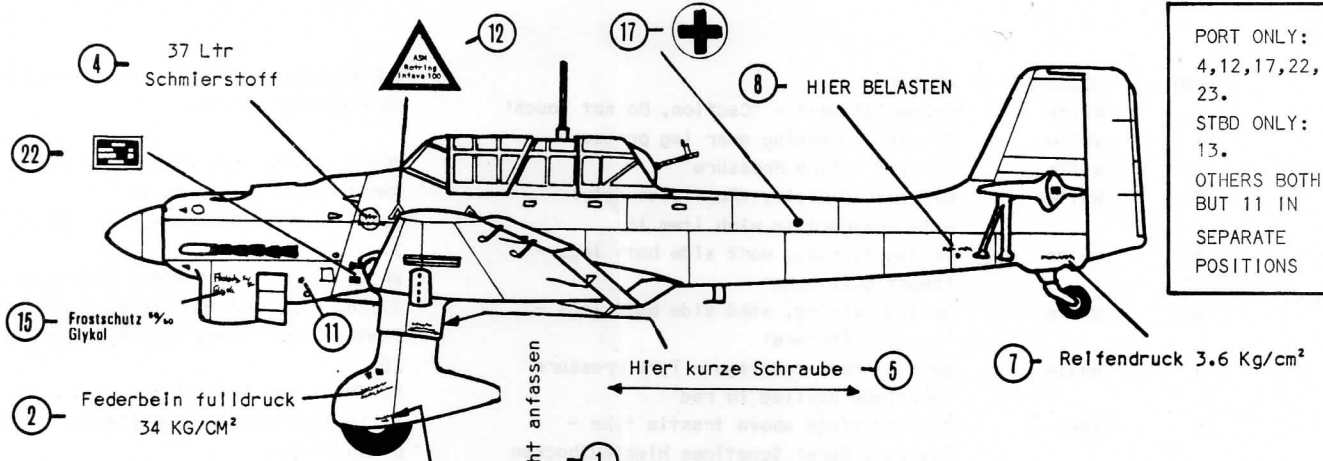

Spannband nach dem Tanken nach ziehen

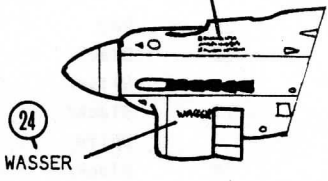
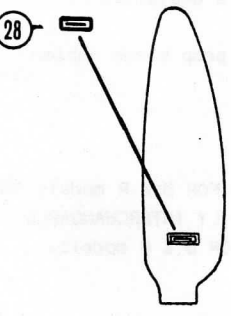
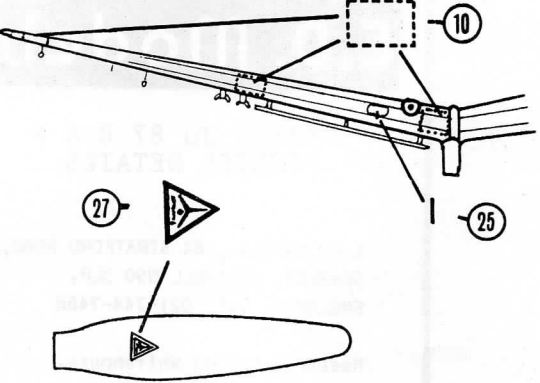
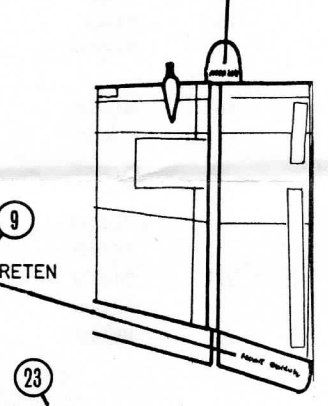
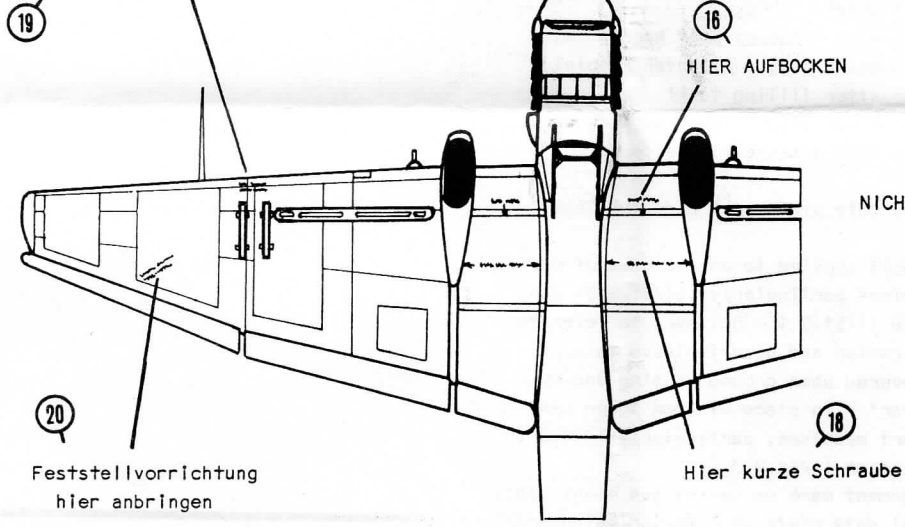

© Les Whitehouse

ITEM	COLOURS	REMARKS
1	White	On aerial mast - 'Caution, Do not Touch'
2	White	On spat - Landing gear leg pressure
3	White	On spat - Tyre Pressure
4	White	Oil tank capacity (Port side only) - in conjunction with item 12
5	White	On leg fairing, port side both legs - 'Short bolt here'
6	White	On leg fairing, stbd side both legs - 'Short bolt here'
7	White	Base of rear fuselage - Tyre Pressure sometimes applied in red
8	Red	Rear fuselage above trestle tube - 'Ballast here' Sometimes Hier Aufbocken 'Jack here'
9	Red	On inboard flap and top of spat - 'No Step'
10	Red	Reinforced areas for lifting wing or aircraft in nose down attitude
11	Red/Black	Electrical socket - Both sides but at different positions
12	Red-Brown & White	Oil Triangle, port side only
13	Blue/White	Oxygen marking, with text 'oxygen, keep free from oil and grease'
14	Yellow/ White	Fuel Triangle, both sides with white arrow pointing to filler cap on wing
15	Black	Coolant marking on radiator cowl
16	Black	'Jack here' - under wing
17	Red/White	First Aid marking on plexiglass panel (Port only)
18	Black	Under wing - 'Short bolt here'
19	Black	On R models only - 'Tighten retaining strap after filling tank'
20	Black	Under outer wing - 'Control lock here'
21	Black/ Silver	Metal data plate either side of spat
22	Black/ Silver	Metal data plate port side fuselage
23	White	Stencil applied to engine cowl of early machines particularly III/St.G 51 and hence II/St.G 1 - Believed to refer to oil cooler and need to leave this uncovered when ground running engine
24	Black	'Water' - In place of item 15 on some desert machines, particularly I/St.G 1 and hence II/St.G 3
25	Red	Alignment mark on camera gun blank plate
26	Black/ Silver	Metal data plate on Elevator balance weight
27	Black/ White	Junkers emblem on early prop blades
28	Black/ White	Later prop blade emblem

NOTE: ITEM NUMBERS FOR B & R models ARE
NOT NECESSARILY INTERCHANGABLE
WITH THOSE FOR D & G models.

THE FOLLOWING STENCILS ARE OMITTED
ON AIRCRAFT STATED:

6G+FR & +AR: Item 23 must be applied
Omit items 2,4,19,24,28.
6G+KT & +AT: Omit items 2,4,23,24,
27.
Wk Nr. 0353: Omit items 2,8,23,24,
27,28. Plus any freshly overpainted.
T6+MP: Omit items 2,4,19,23,24,27,
28.
S7+CM: Omit items 2,3,4, Top half
of 10,19,23,27,28. Use item 24 in the
place of 15.
A5+IL: As S7+CM but note SS in WASSER
like the SS runes on this a/c.
L1+CW & +DW: Use sand background to
stencils and Omit 2,4, Top half of
10,23,24,27,28.

E.D. Models

JUNKERS Ju 87 B & R
STENCIL DETAILS

E.D. MODELS., 64 STRATFORD ROAD,
SHIRLEY, SOLIHULL B90 3LP,
ENGLAND. Tel: 021-744-7488

Research by Les Whitehouse.