

1/48 SCALE MODEL CONSTRUCTION KIT



Morane-Saulnier MS406C.1

DW 48031

The model was created from original drawings kindly provided by Sosthene Billault Waroff.
The color options were reproduced under the direction of Franciszek Strzelczyk.
Many thanks for the help!

PARTS OF THE MODEL

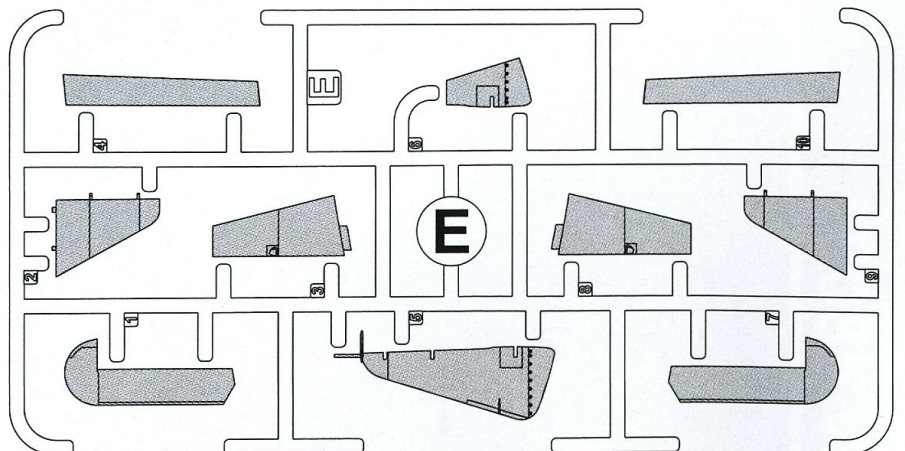
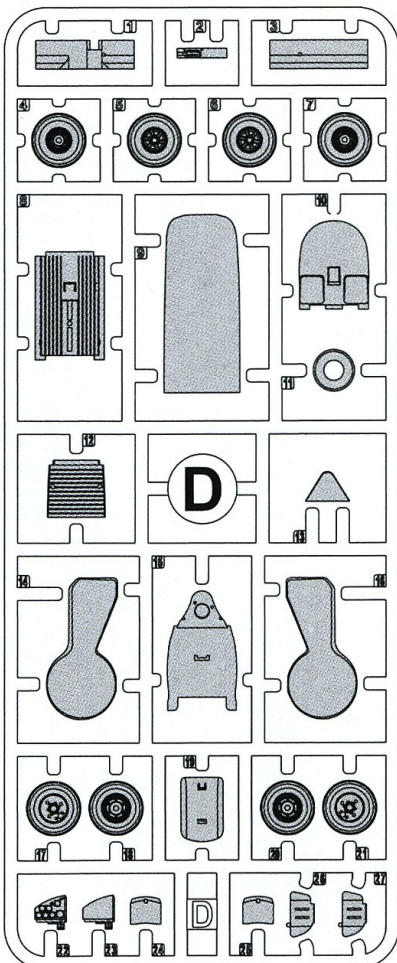
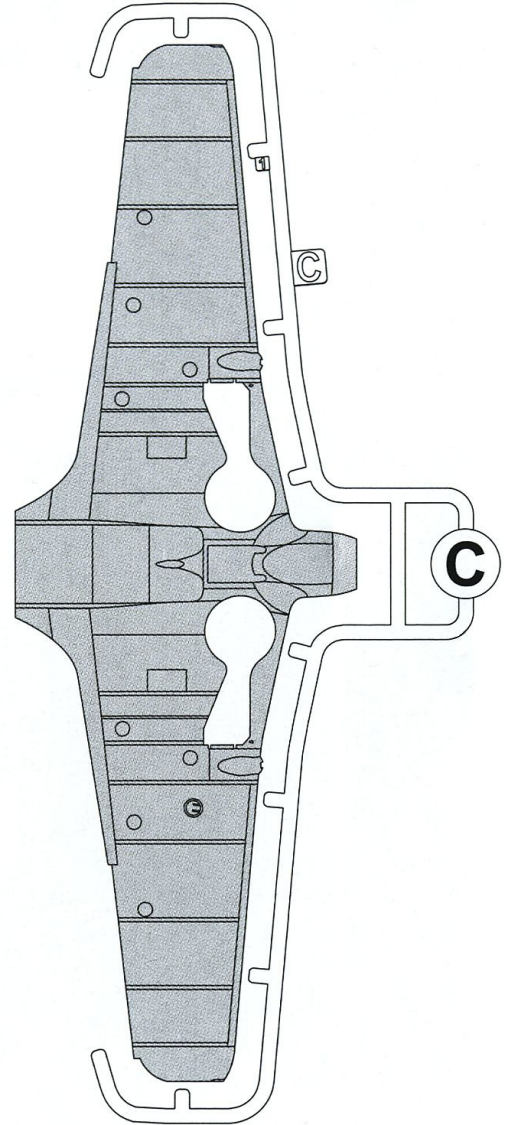
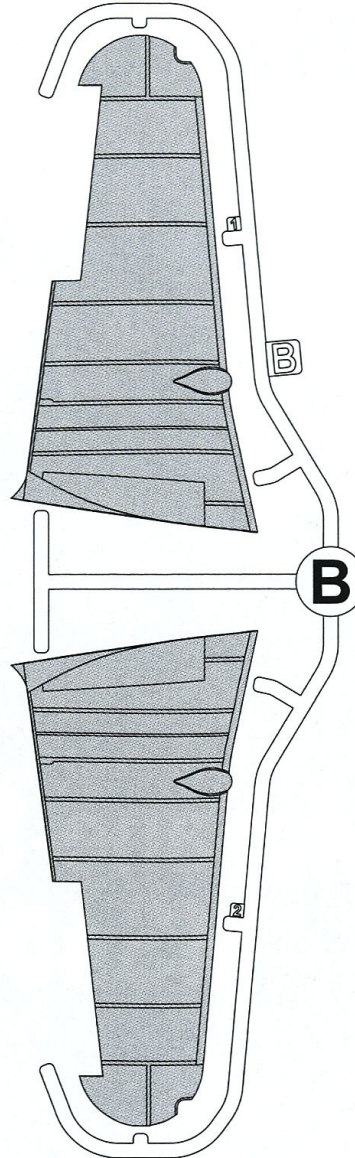
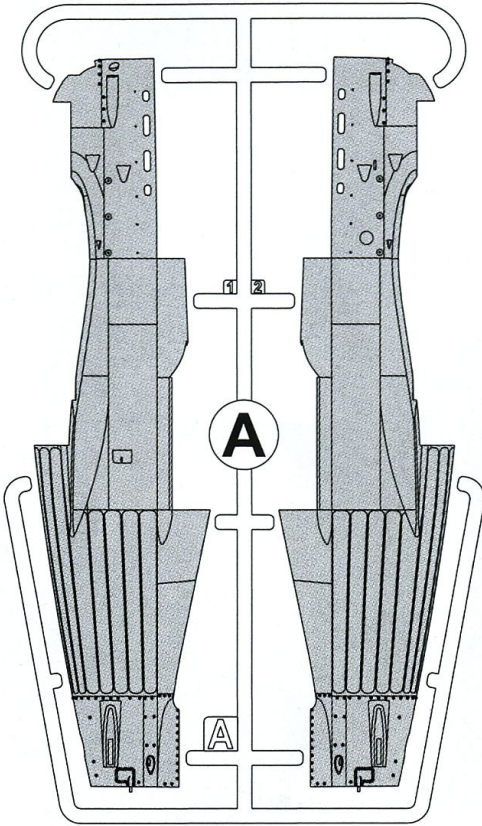

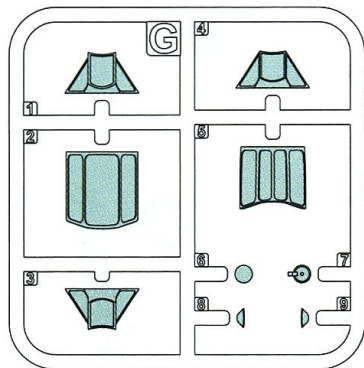
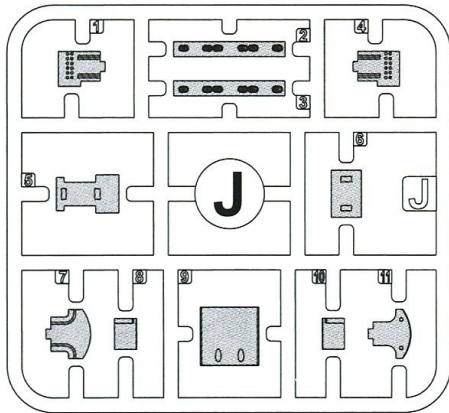
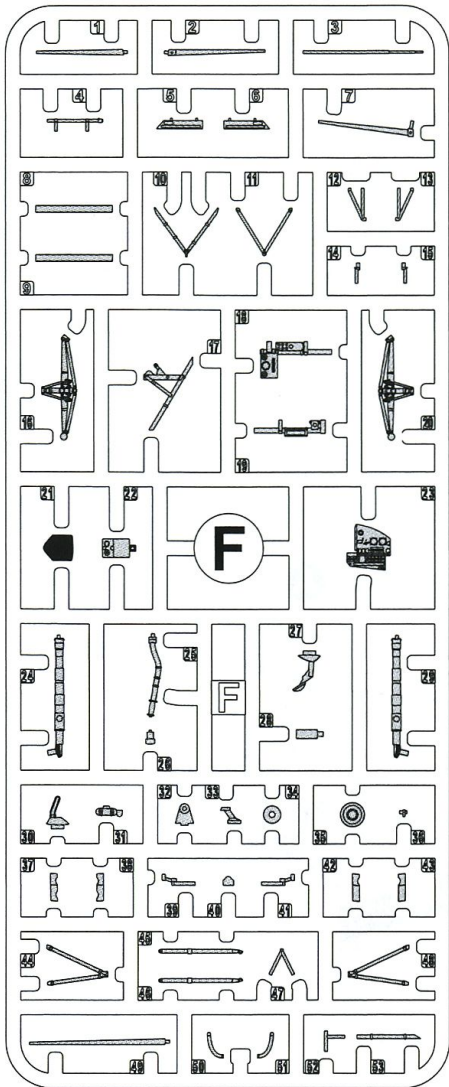

G

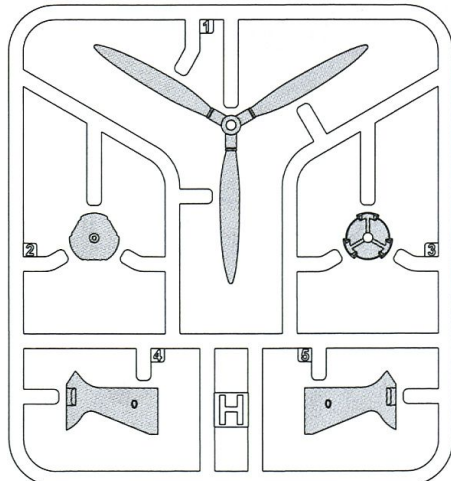

H

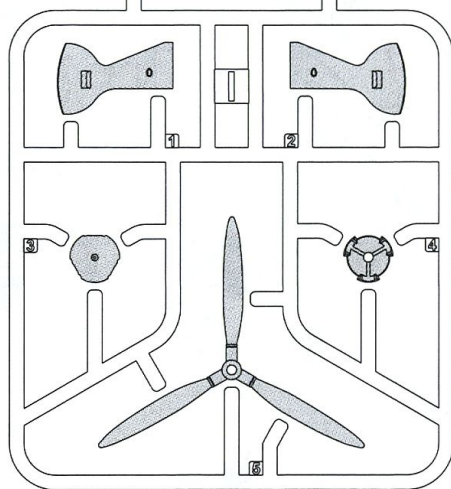

Decal

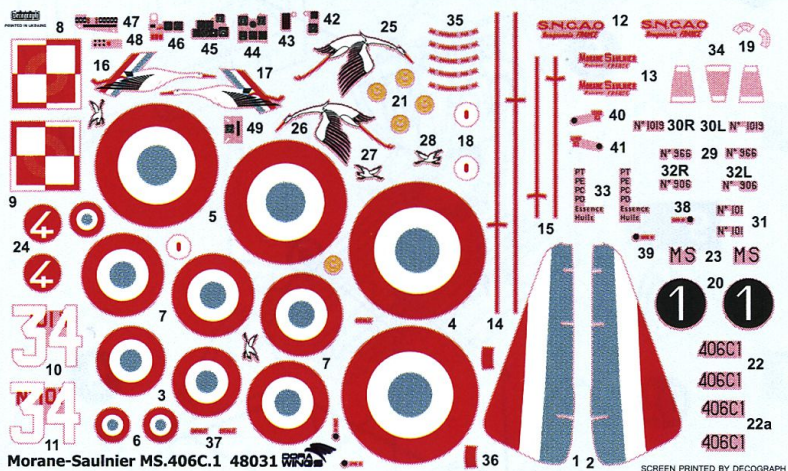

Mask

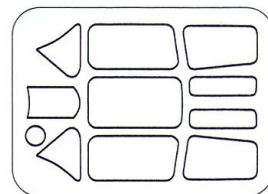

PE

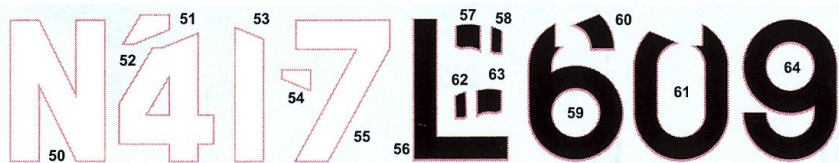
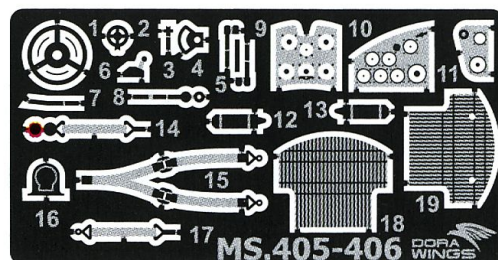

ASSEMBLY INSTRUCTION

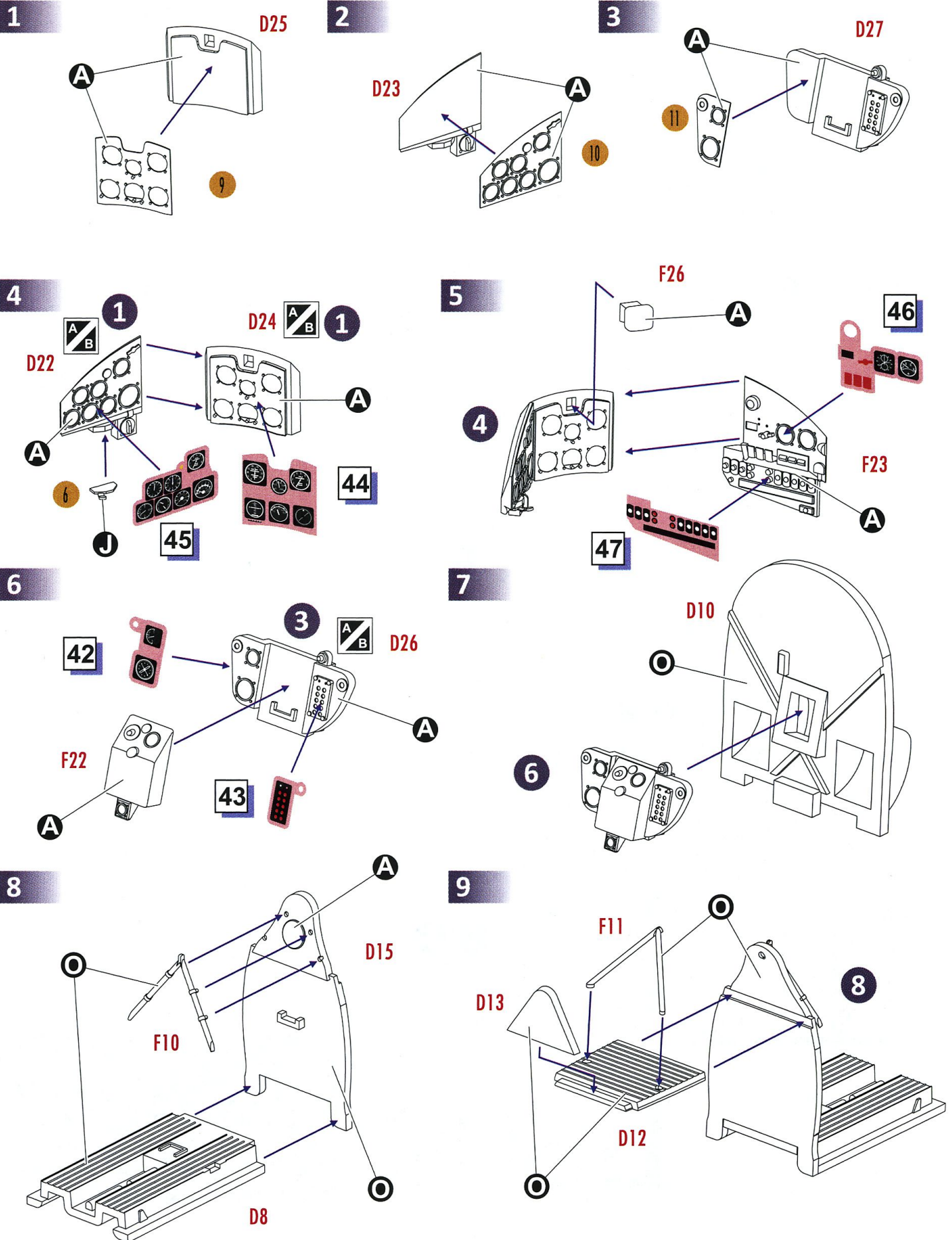

10

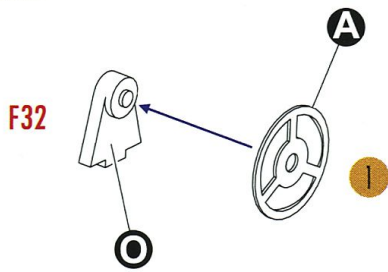

11

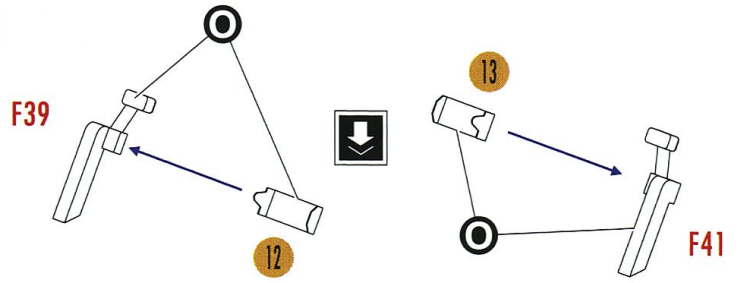

12

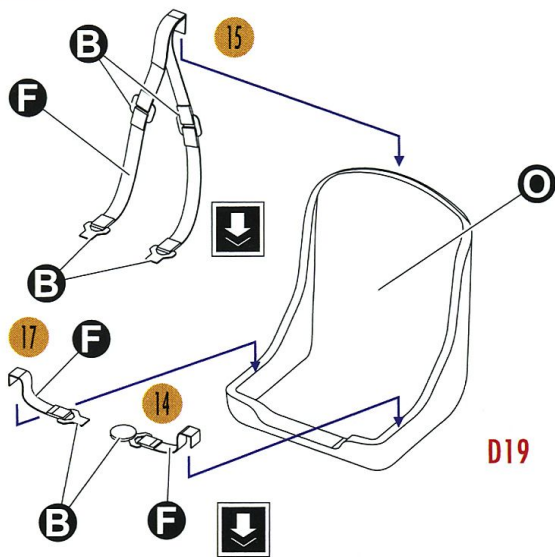

13

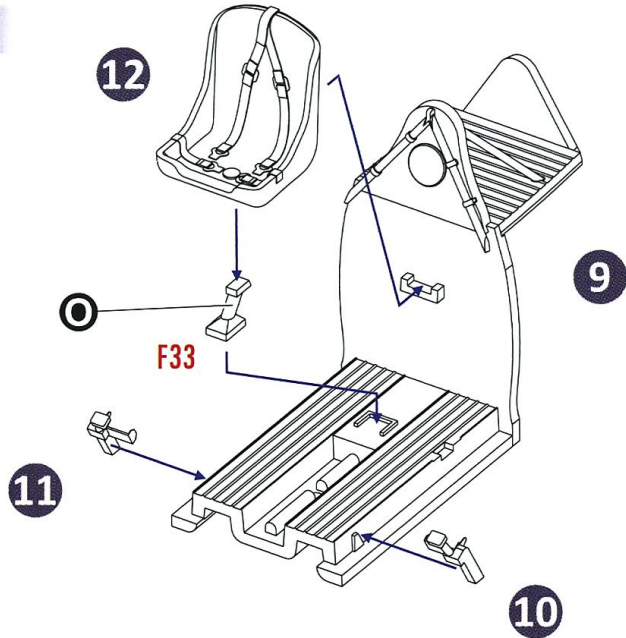

14

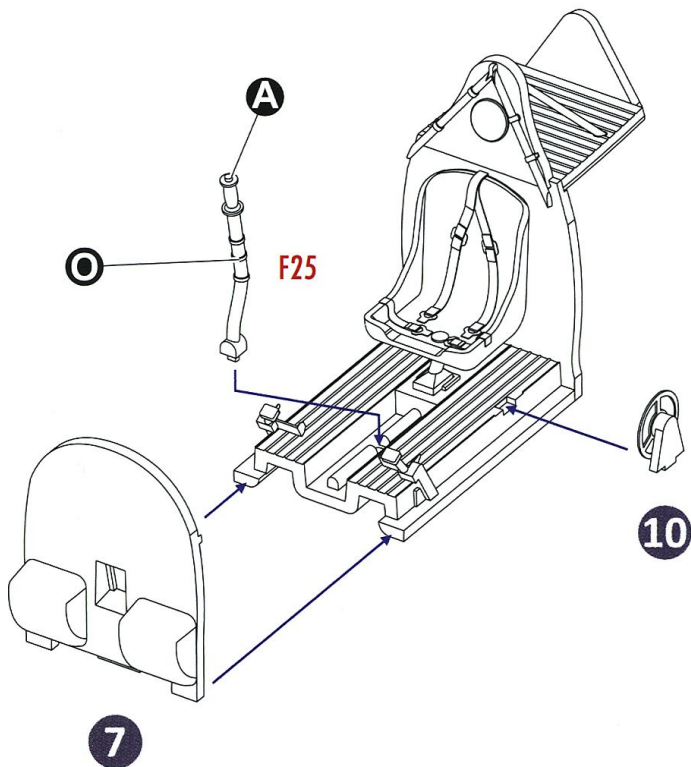

15

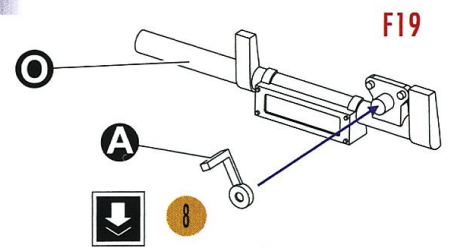

16

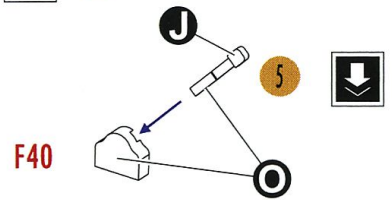

17

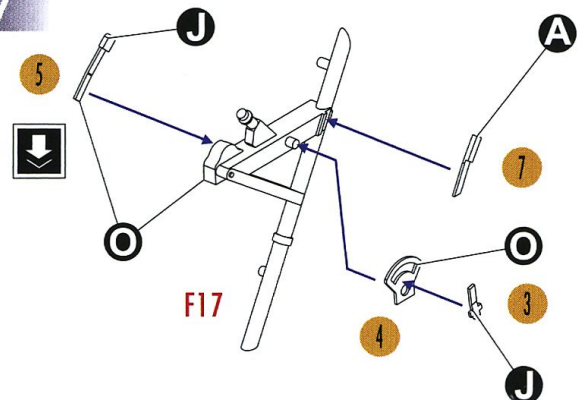

18

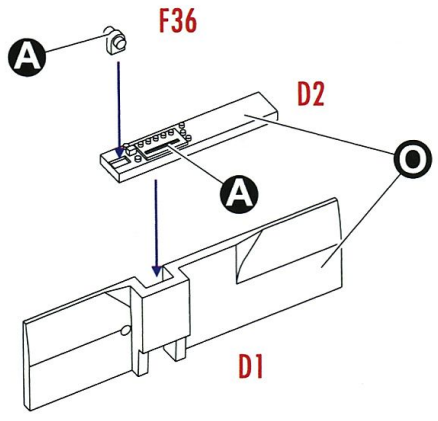

19

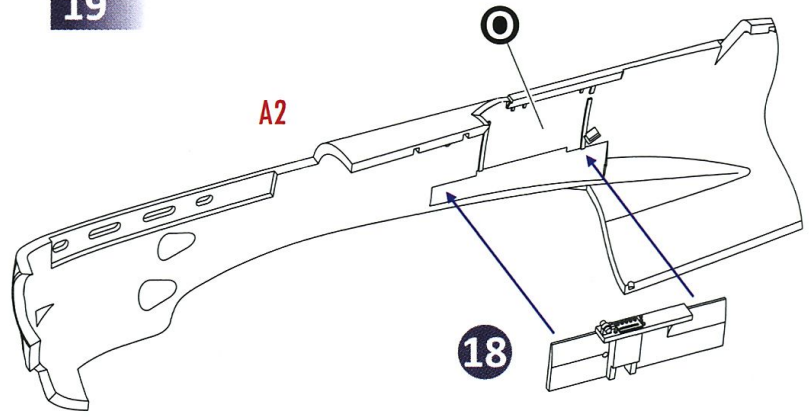

20

19

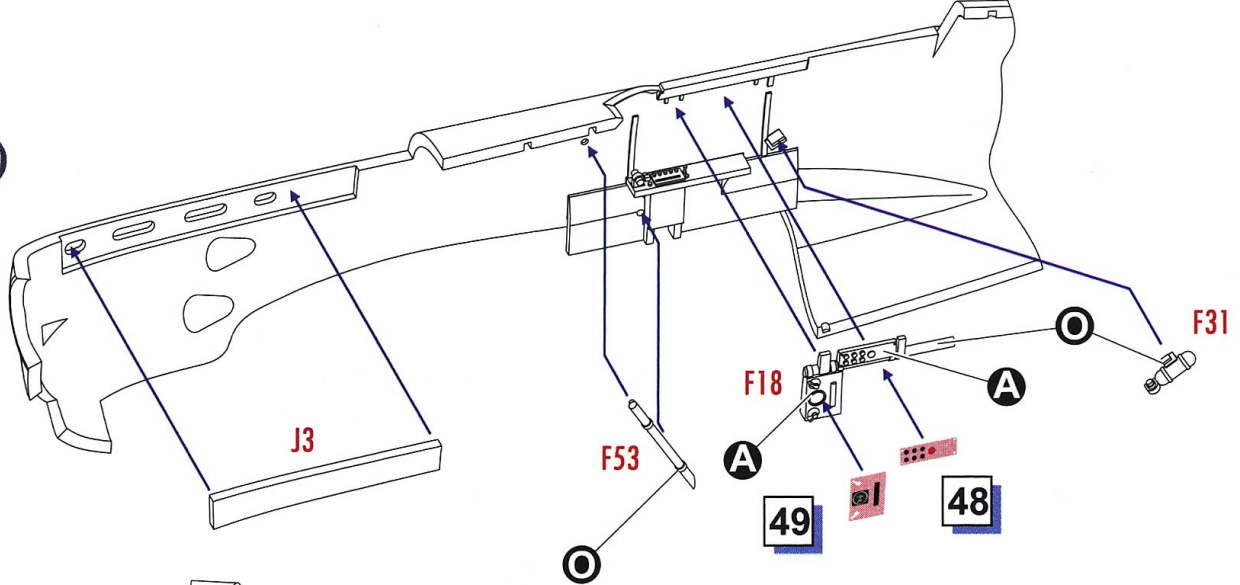

21

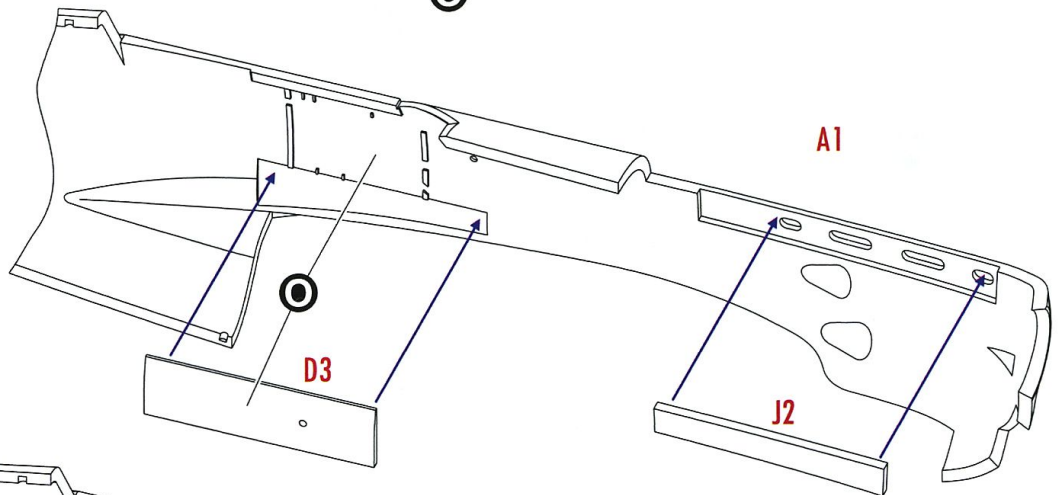

22

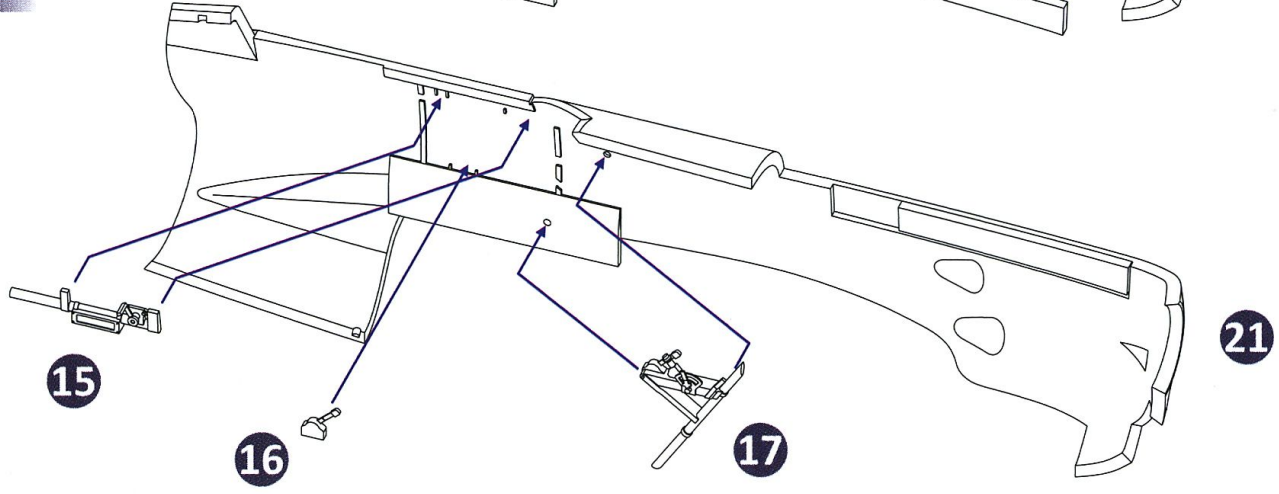

23

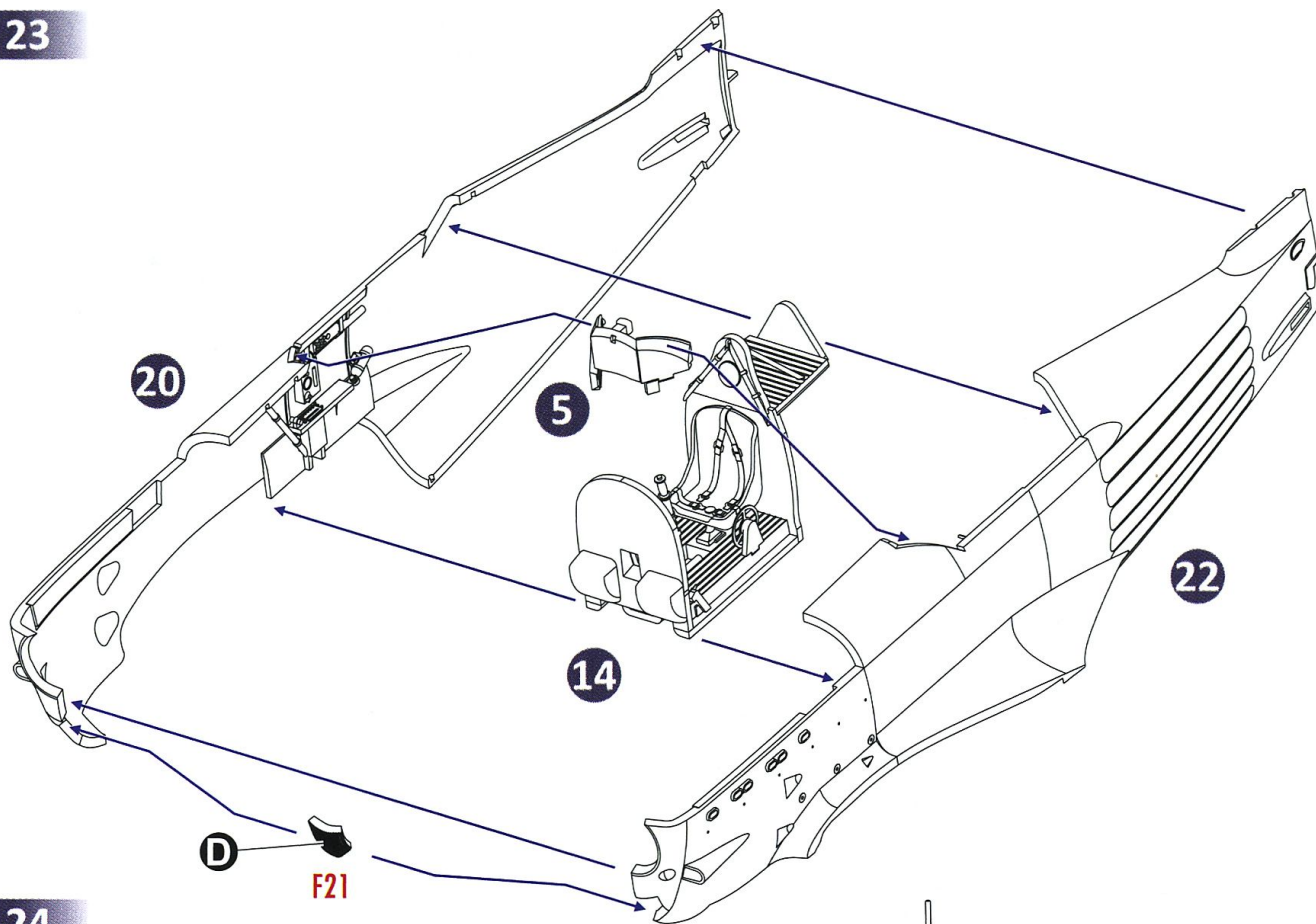

24

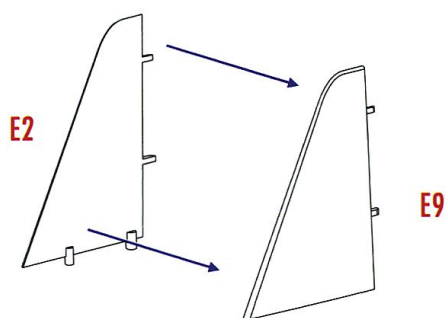

25

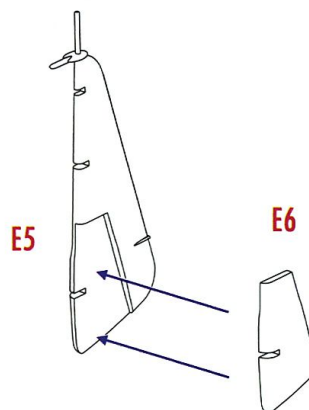

26

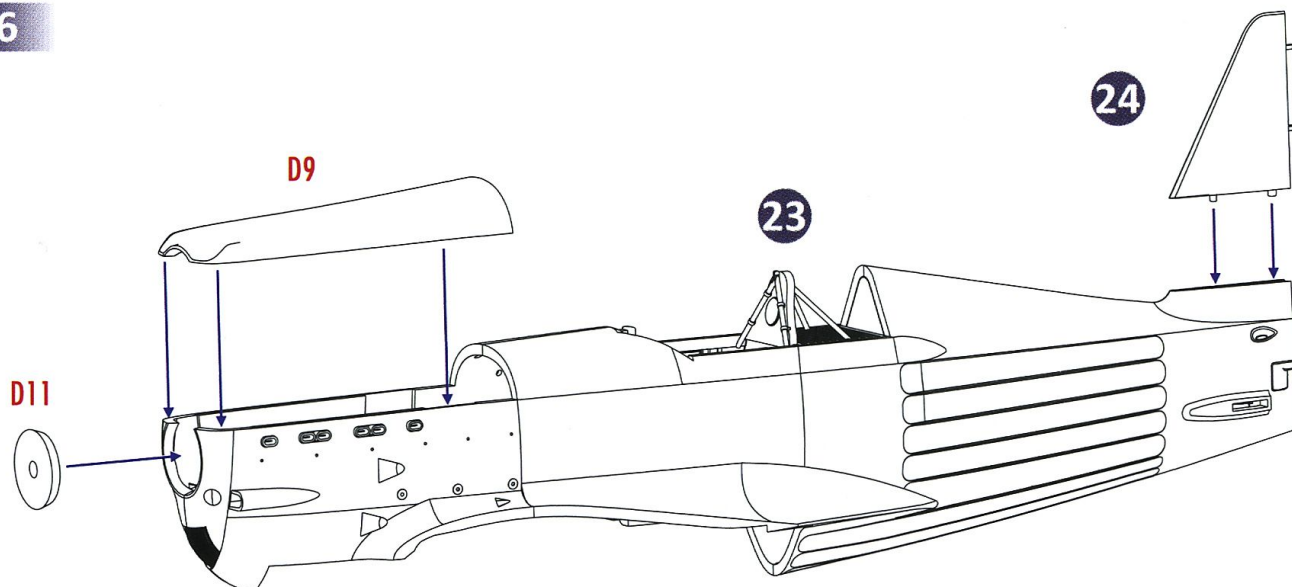

27

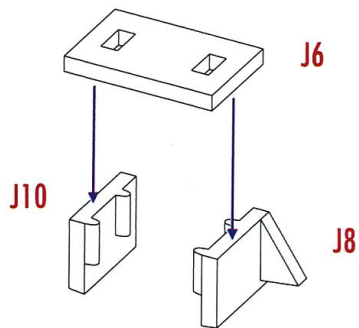

28

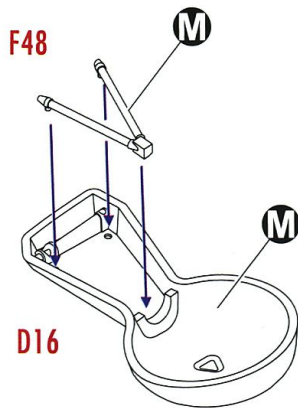

29

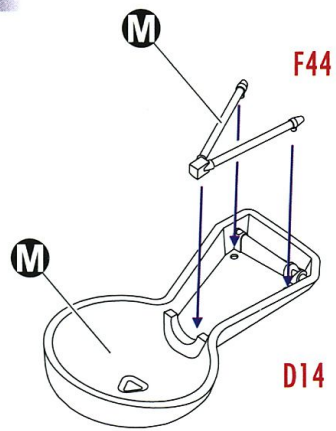

30

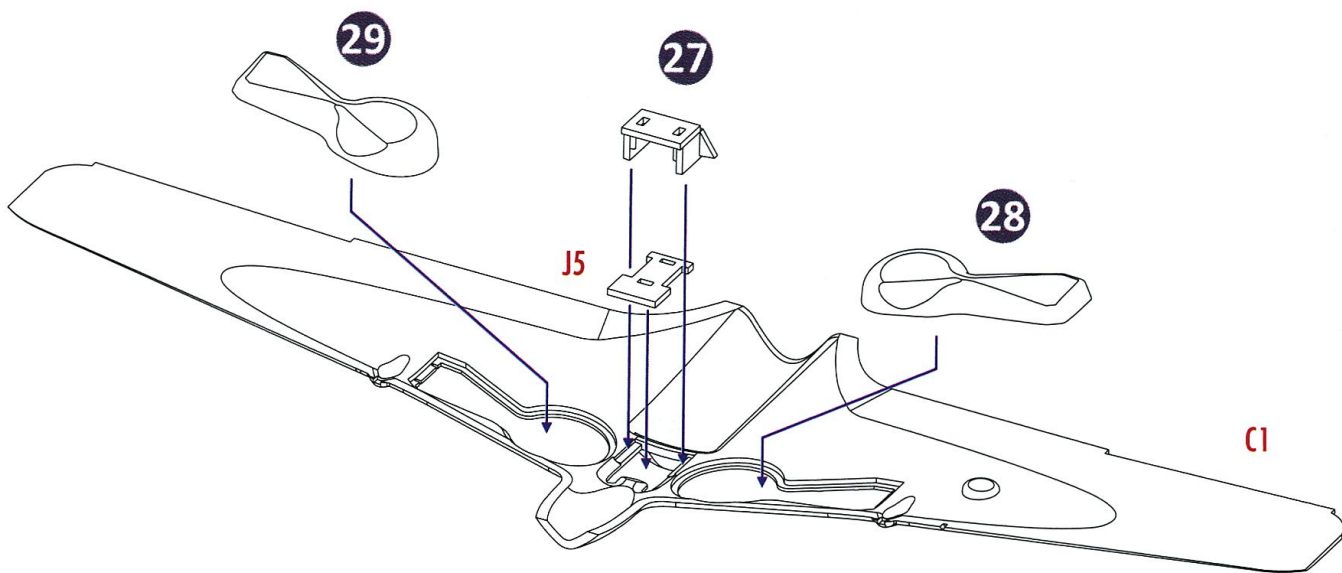

31

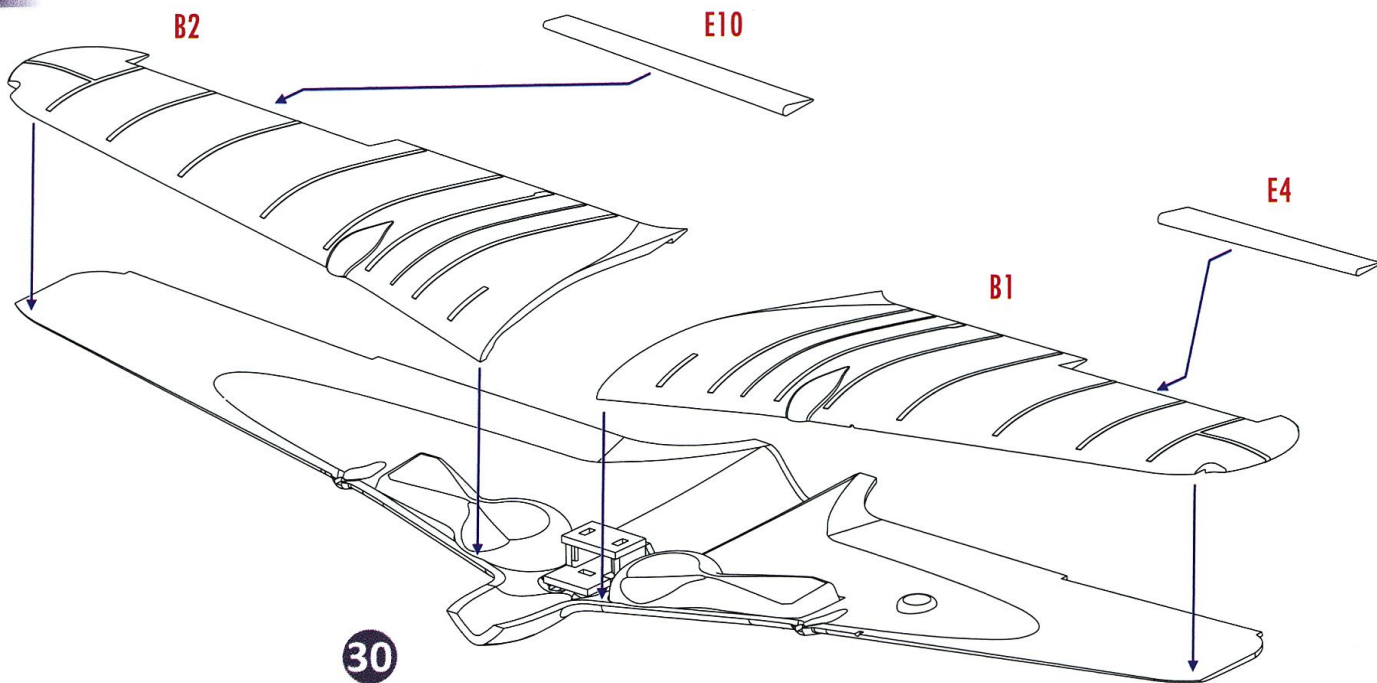

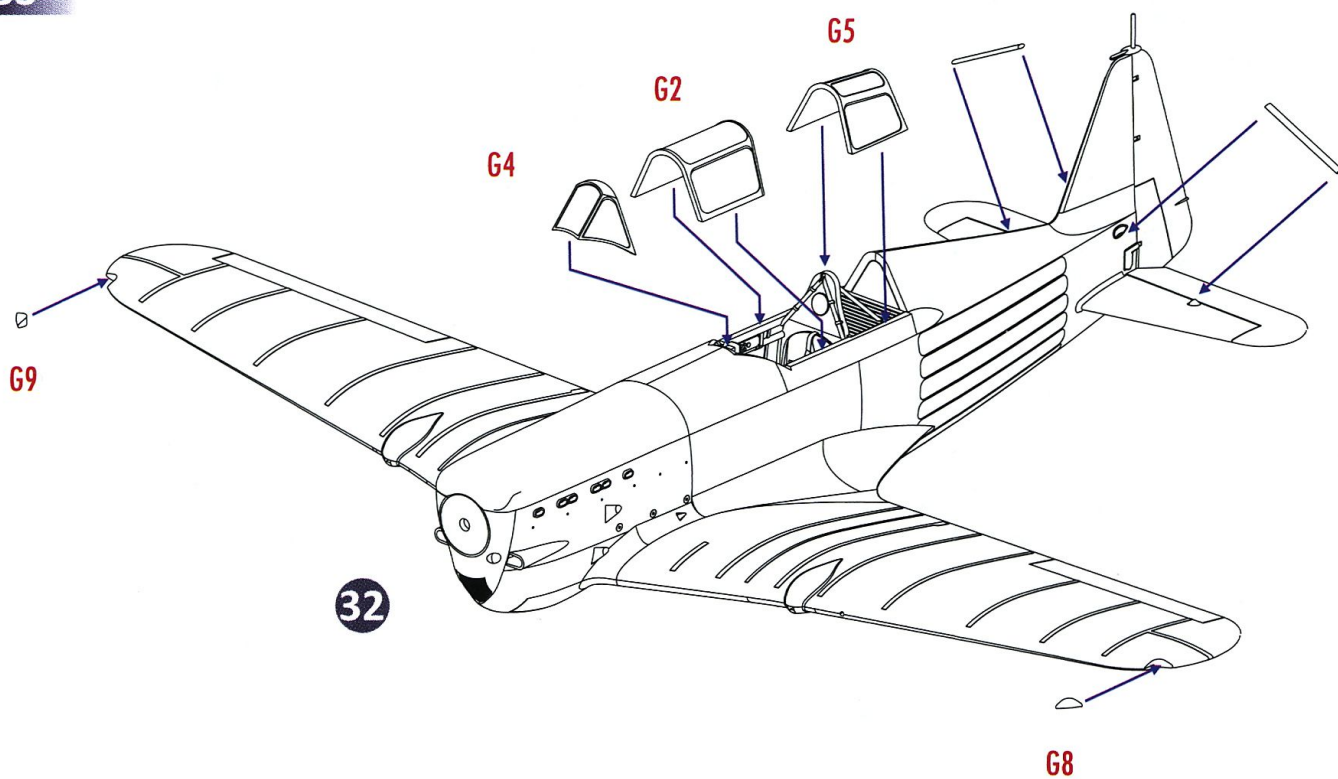
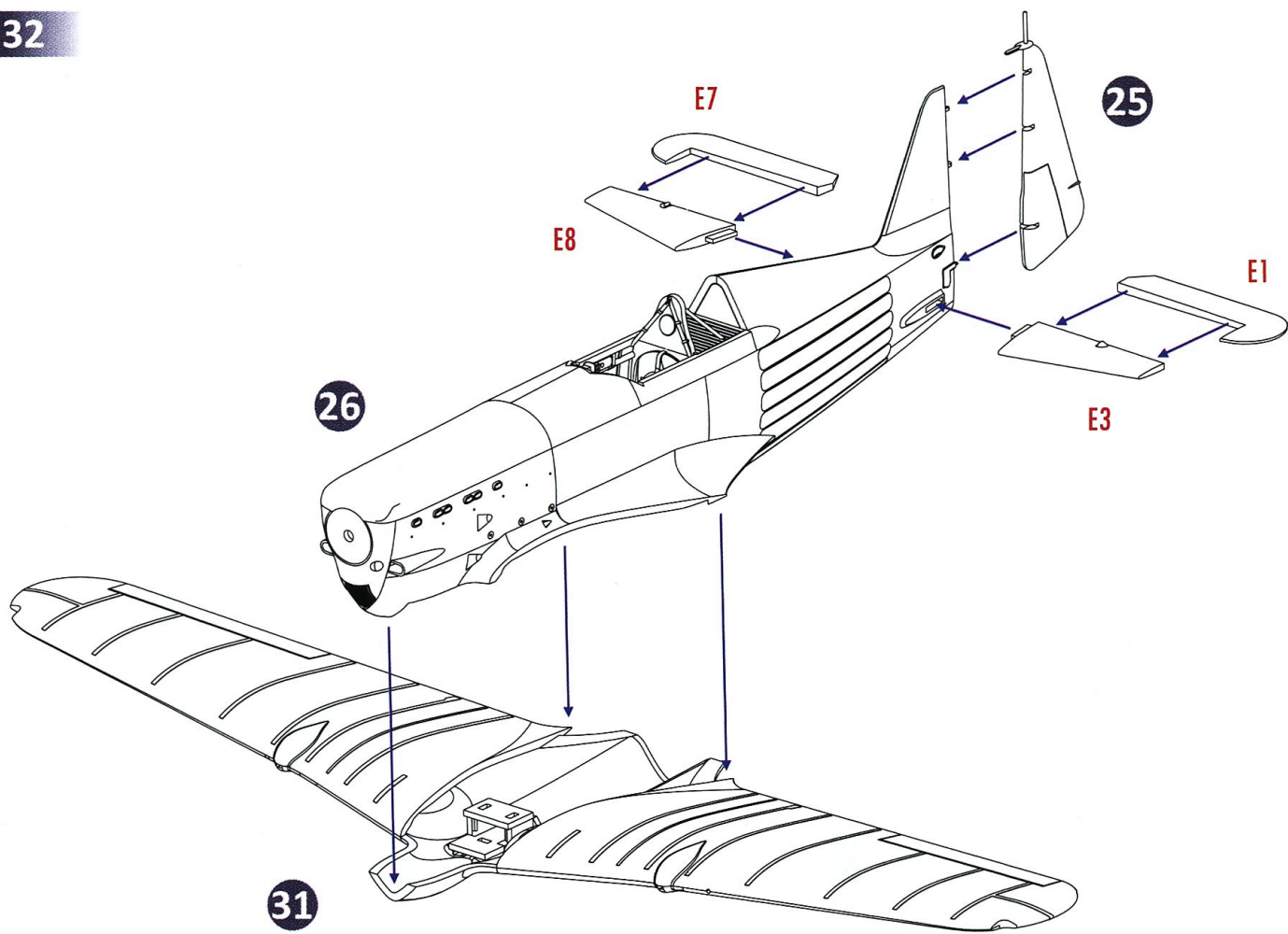

34

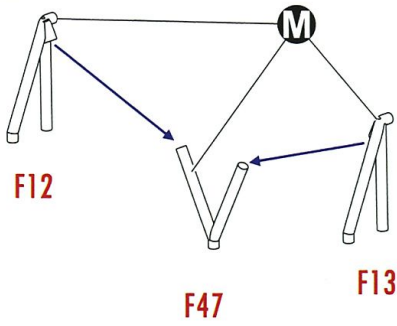

35

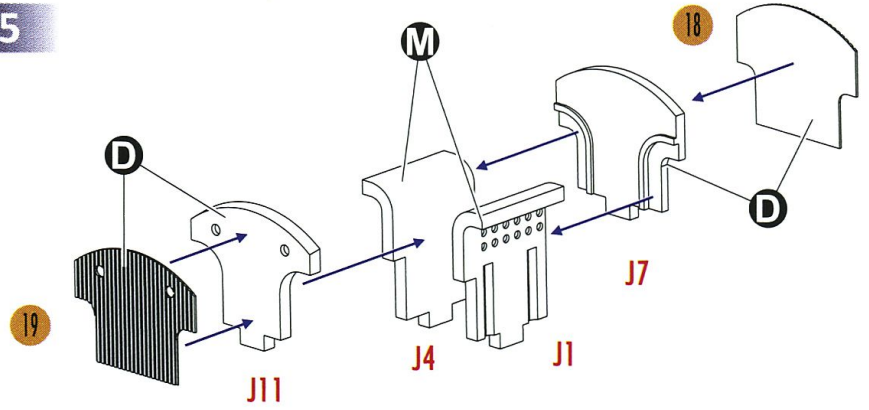

36

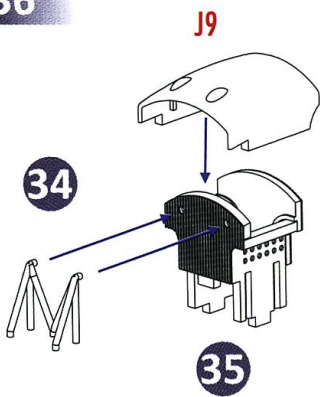

37

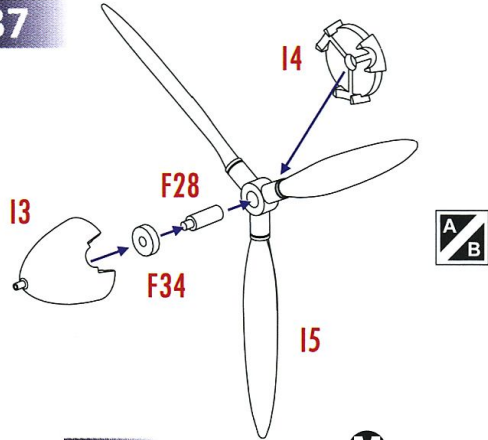

38

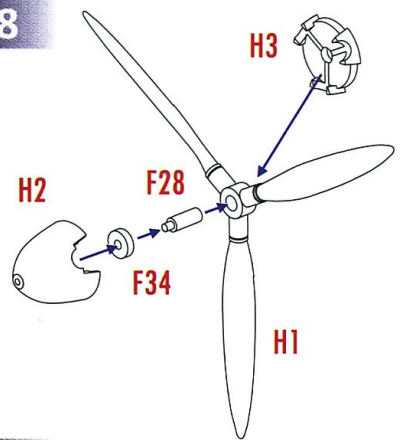

39

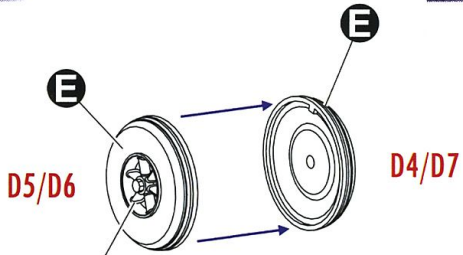

40

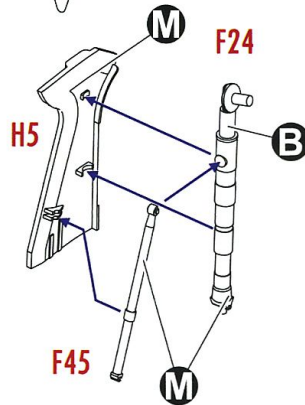

41

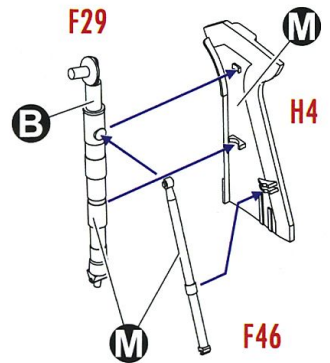

42

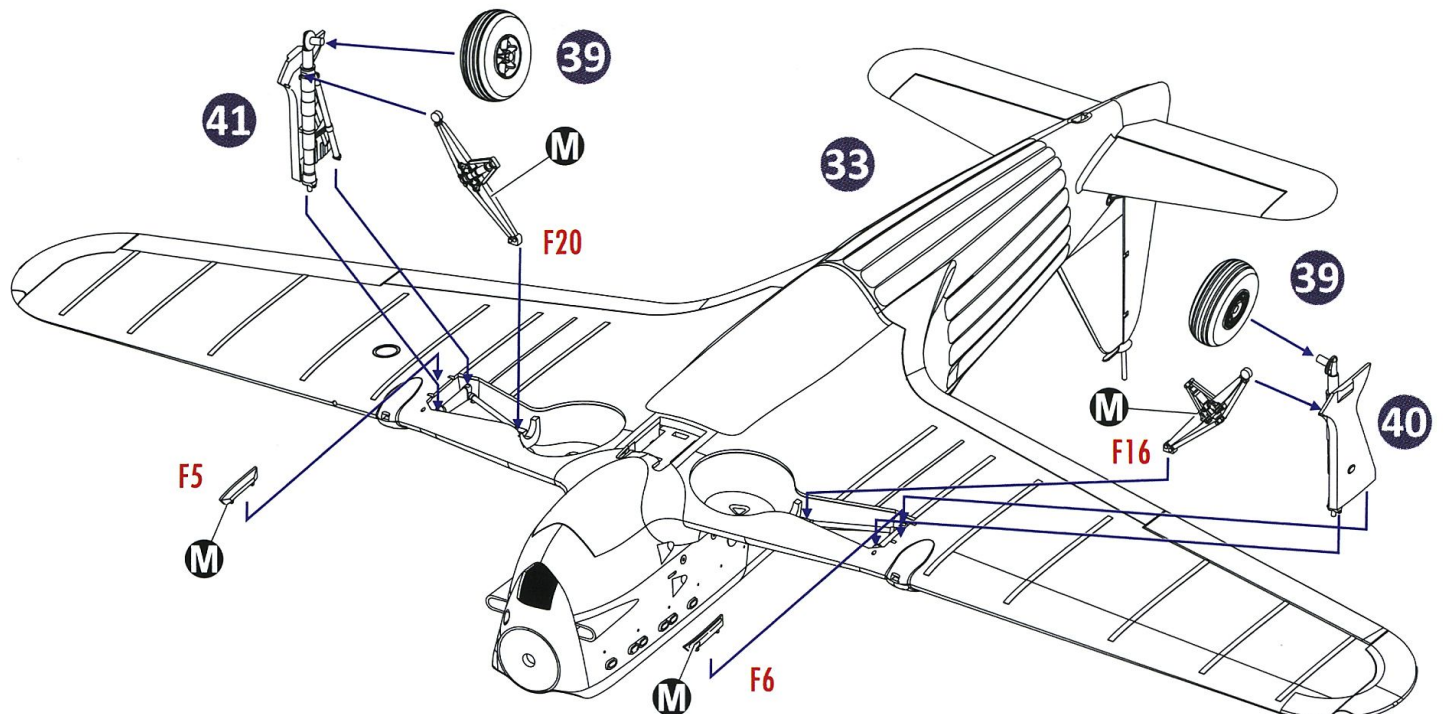

43

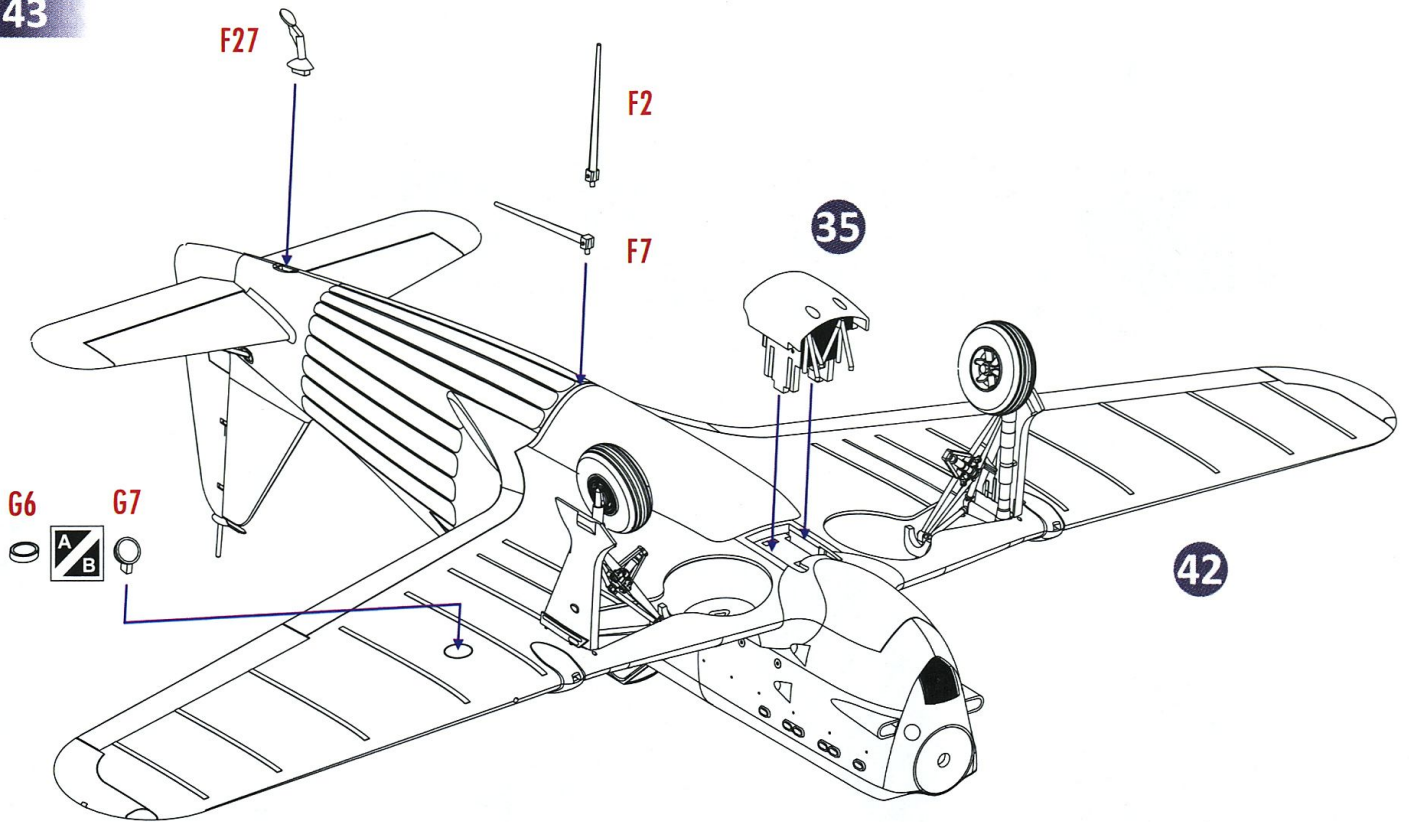

44

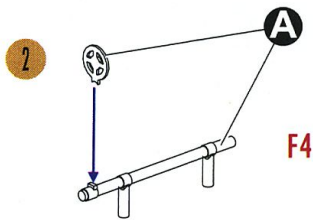

44

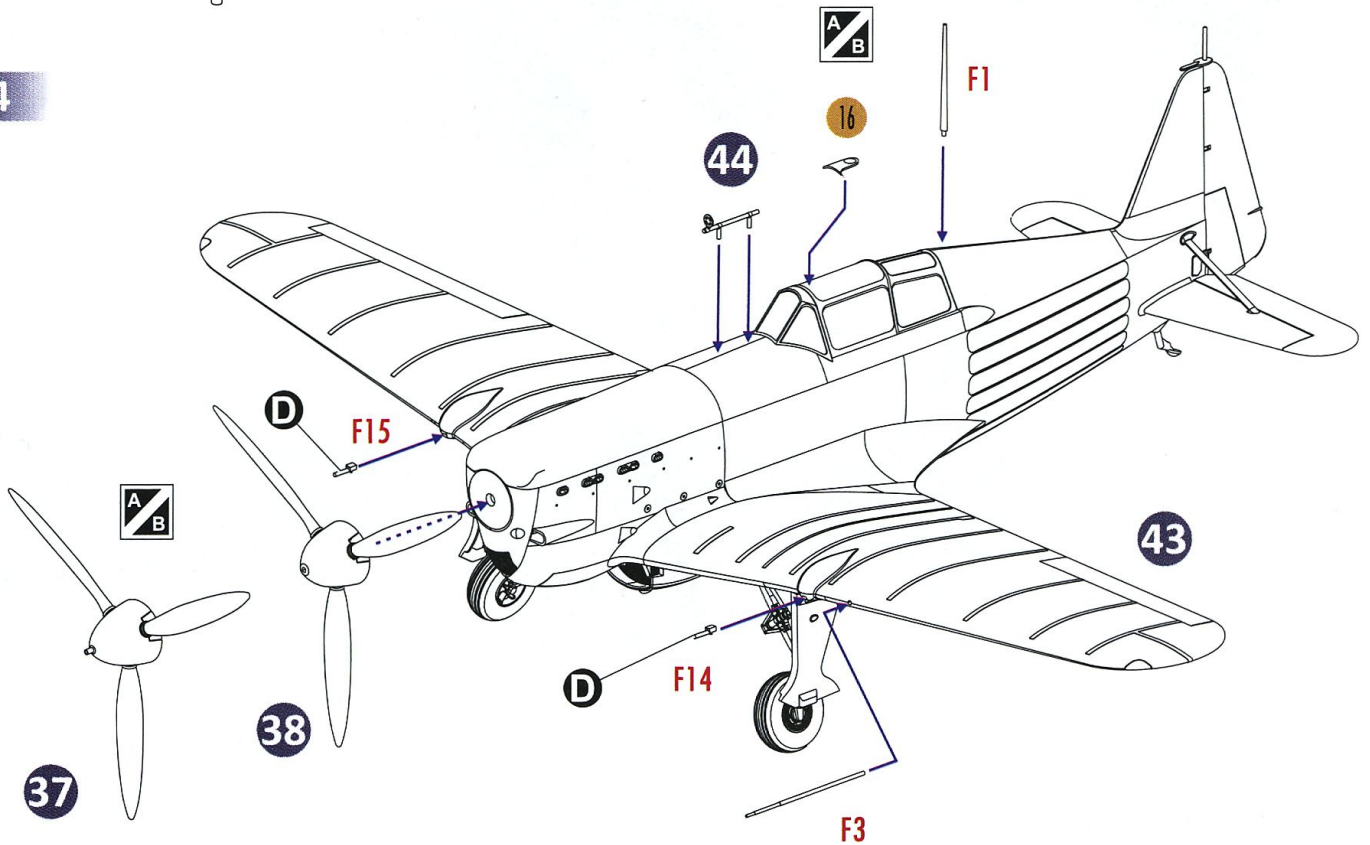

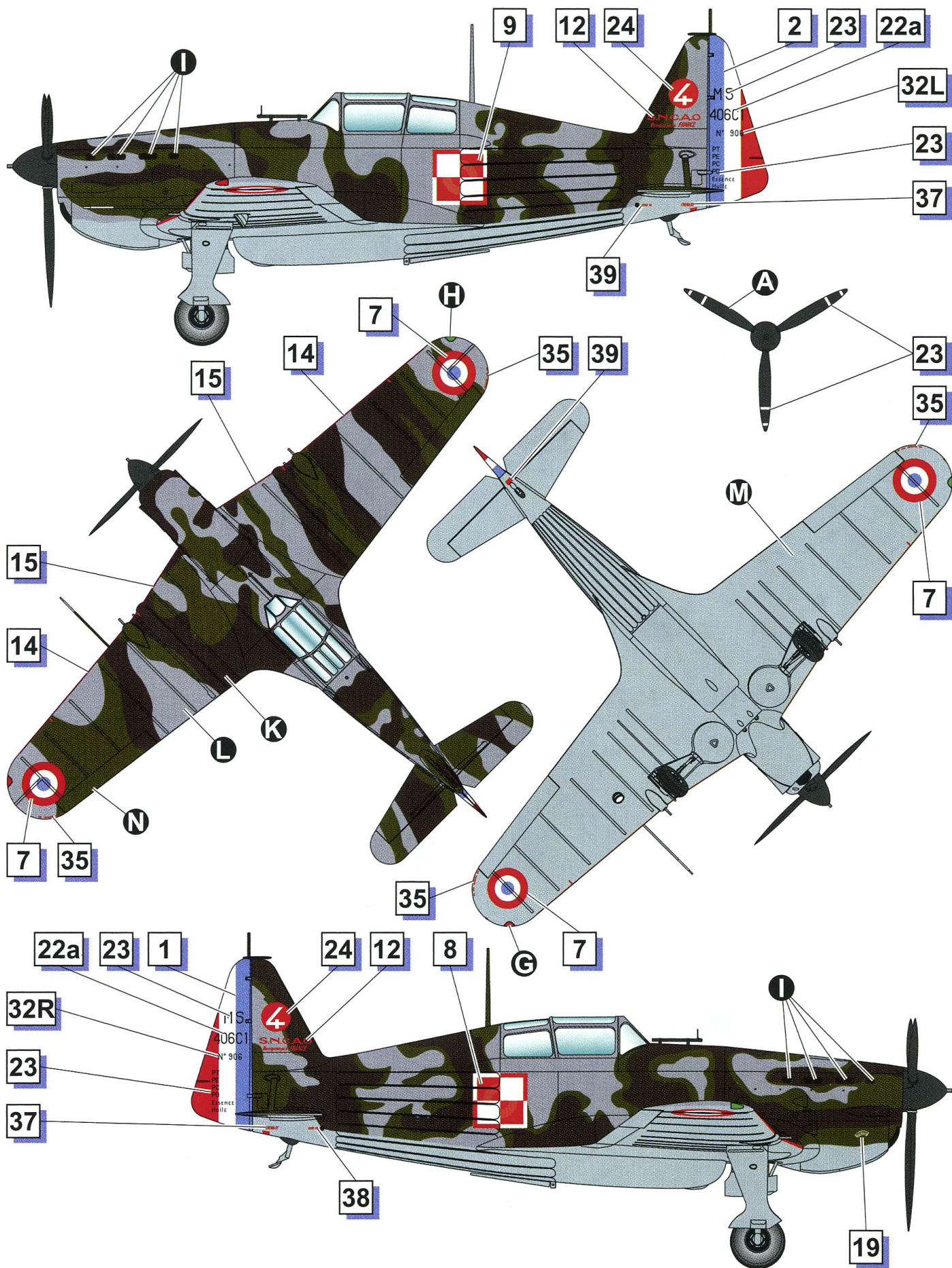

MS.406 №906, pilot Cpl. Edward Uchto,
Fighter Training Flight, DIAP Lyon-Bron, June 1940

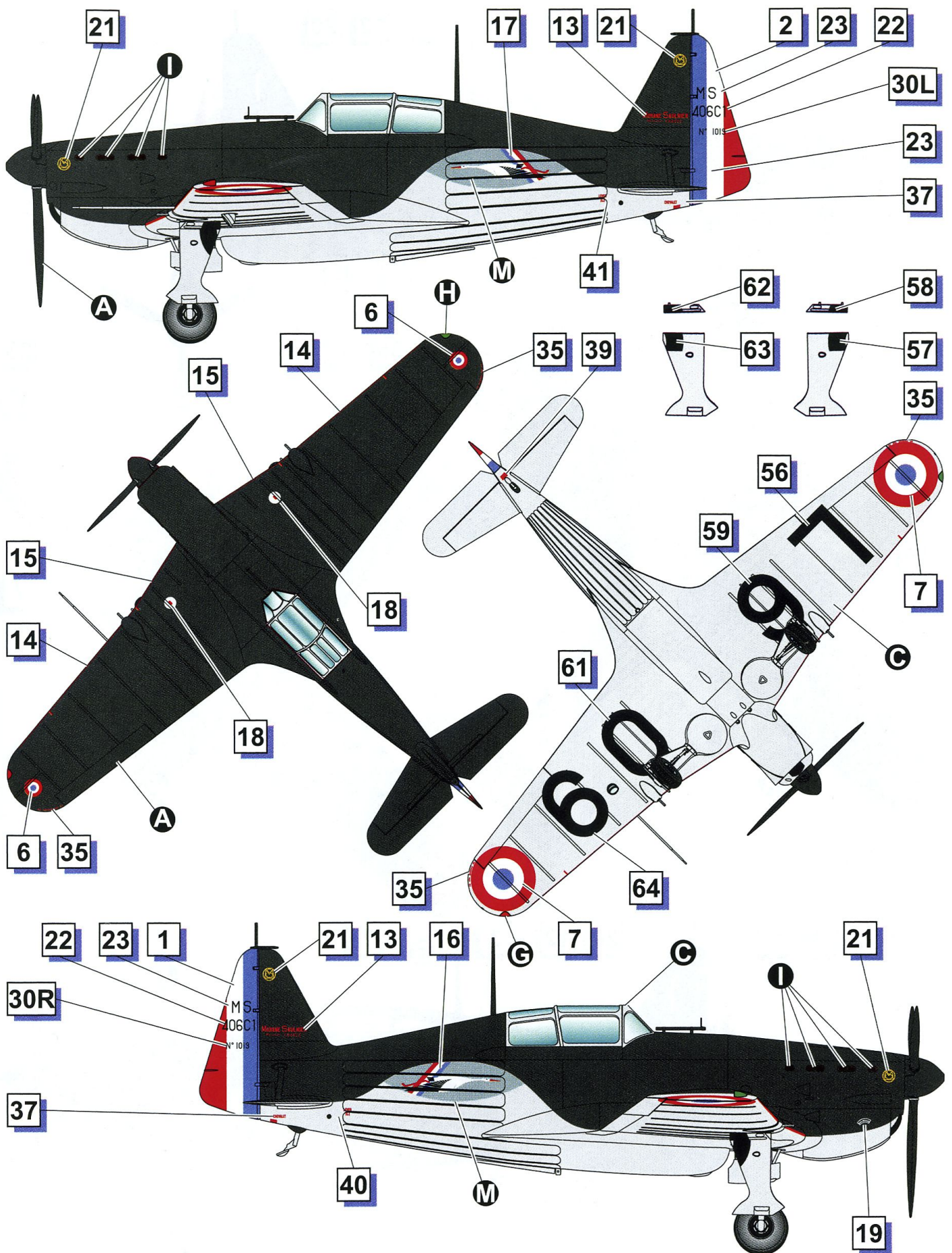

MS.406 №1019, named "Le Pirate". Personal airplane
 General Armand Pinsard (27 victories in WW1), Commandant Groupment
 de Chasse 21, May 1940

Morane-Saulnier MS.406C.1

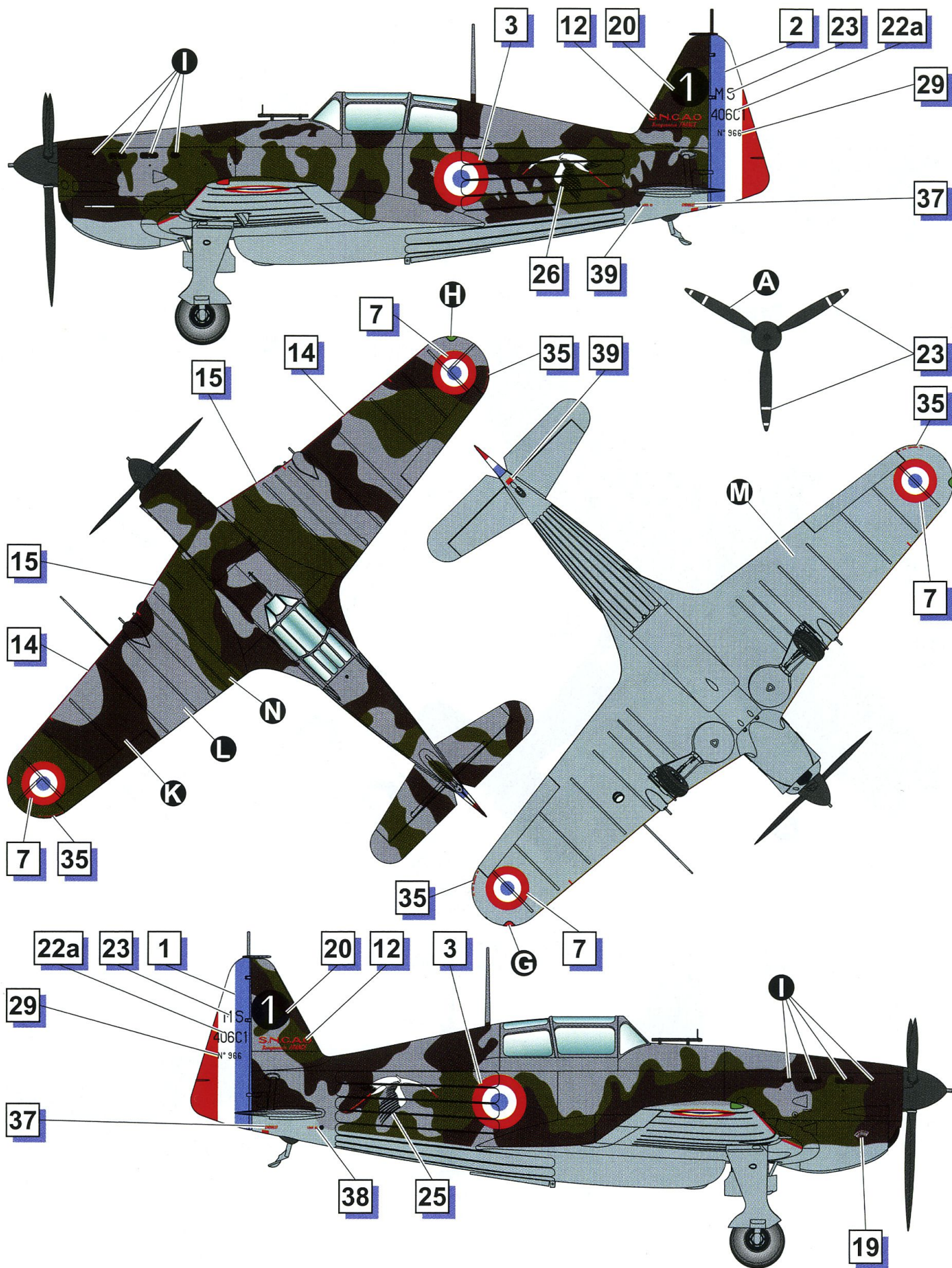

MS.406 №966, pilot Captain Robert Williame,
 commander of the 1st squadron GC1/2, Damblain, April 1940.

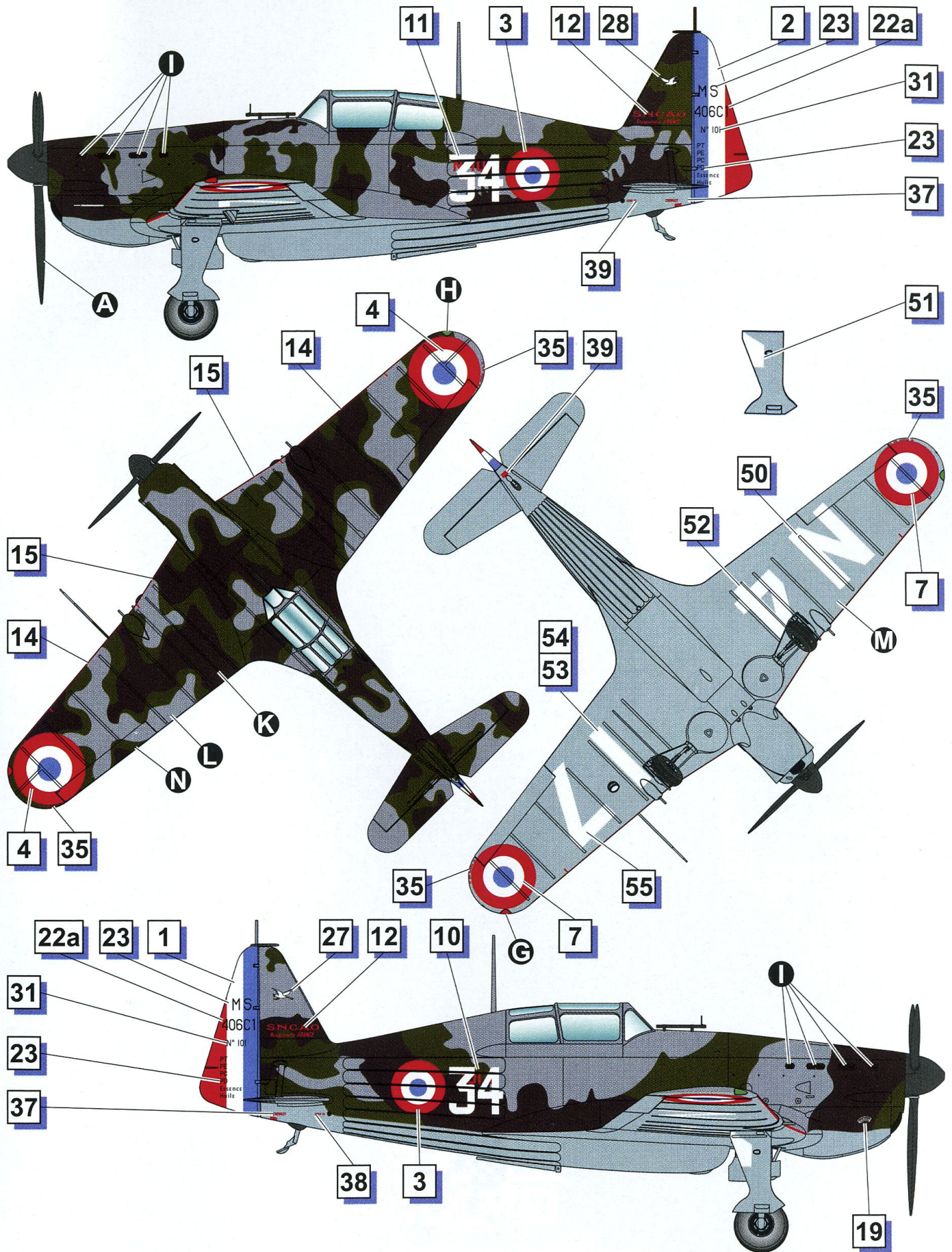

MS.406 №101, pilot Sgt. Miroslav Jiroudek,
Groupe de Chasse III/1, 6 Esc., Norrent-Fontes, June 1940

COLOR TABLE

Color Chart		MR. HOBBY	Tamiya	AMMO MIG	Hataka	LIFECOLOR
Black	A	C33/H12	XF-1	MIG 046	HTK 100	LC 02
Silver	B	C8/H8	X-32	MIG 195	HTK B003	LC 74
Aluminium	C	MC 218	XF-16	MIG 194	HTK 078	LC 24
Gun Metal	D	C78/H28	X-10	MIG 045	HTK 106	LC 26
Rubber Black	E	C137/H77	XF-85	MIG 035		UA 733
Tan	F	C44/H27	XF-55	MIG 202	HTK 187	LC 15
Clear Red	G	C47/H90	XF-27	MIG 093		
Clear Green	H	C138/H94	XF-25	MIG 092		
Burn Iron	I	C61/H76	XF-25	MIG 187		LC 37
Signal Red	J	C79/H11	XF-2	MIG 049	HTK-103	LC 56
Brun Fonce	K	H84/H17 (50:50)	XF-52+ XF-10+XF-2 (5:5:1)		C 079	UA 143
Gris Bleu Fonce	L	H56/H11 (50:50)	XF-53+ XF-2 (5:2)		C 082	UA 141
Gris Bleu Clair	M	H67/H11 (50:50)	XF-23+ XF-2 (5:2)		C 083	UA 145
Khaki Francais	N	H80/H11(70:30)	XF-49+ XF-2 (5:2)		C 084	UA 142
Bleu Nuit Interieur	O	C366/H56	XF-18	MIG 228	HTK 027	UA 45



USED SYMBOLS



CEMENT



DON'T CEMENT



REMOVE



SYMMETRICAL



MULTIPLE



BEND



OPEN WHOLE



VARIANTS



TO PAINT