



# B-26B Marauder

1/48 SCALE MODEL KIT No 48323

## B-26G Marauder

### Американський/французький бомбардувальник 2 СВ

Модифікація B-26G Marauder випускалася заводом Glenn L. Martin Co. у Міддл-Рівер, штат Меріленд та стала останньою у лінійці цих бомбардувальників. Літаки мали змінений кут установки крила – його підняли вгору на 3,5 градуса. Така зміна мала покращити керованість на зльоті та посадці, бо ці операції були складними для екіпажів Marauder. Також у цій модифікації дещо змінили частину внутрішнього обладнання, його стандартизували під загальні вимоги для армії та флоту. Усього було випущено 893 бомбардувальники B-26G Marauder, вони знаходилися на озброєнні кількох авіаційних груп США, що діяли в Європі. Також частина цих літаків стояла на озброєнні військово-повітряних сил «Вільної Франції». Французькі бомбардувальники спочатку воювали в Італії та на півдні Франції, проте з просуванням союзників у Європі вони застосовувалися і в інших регіонах. Останній виліт екіпаж французьких Marauder здійснили 25 квітня 1945 року.

### Тактико-технічні характеристики B-26G Marauder

Довжина, м	17,3
Розмах крила, м	21,64
Нормальна злітна вага, кг	17330
Двигуни	2 x Pratt & Whitney R-2800-43, 2x1920 к.с.
Максимальна швидкість, км/год	440
Практична стеля, м	6030
Дальність польоту, км	1770
Озброєння	11 x 12,7 мм кулеметів, до 1814 кг бомб

## B-26G Marauder

### WWII American/French Bomber

The B-26G Marauder modification was produced by the Glenn L. Martin Co. in Middle River, Maryland, and became the final variant in the Marauder line. The aircraft featured a modified wing angle—raised by 3.5 degrees. This change was intended to improve handling during takeoff and landing, as these operations had been challenging for Marauder crews. Additionally, some internal equipment was standardized in the B-26G to meet the common requirements of both the Army and Navy. A total of 893 B-26G Marauder bombers were produced, and they were used by several U.S. Army Air Force groups operating in Europe. Some of these aircraft were also in service with the French Air Force, known as the «Free French». The French Marauders initially fought in Italy and southern France, but as the Allies advanced in Europe, they were deployed in other regions as well. The final mission flown by French Marauder crews took place on April 25, 1945.

### Tactical and Technical Specifications of B-26G Marauder

Length, m	17,3
Wingspan, m	21,64
Max take-off weight, kg	17330
Engines	2 x Pratt & Whitney R-2800-43, 2x1920 hp
Max. Speed, km/h	440
Service Ceiling, m	6030
Max ferry range, km	1770
Armament	11 x 12,7 mm machine guns, up to 1814 kg of bombs

## ФАРБИ, ЩО ВИКОРИСТОВУЮТЬСЯ / USED COLORS:

COLOR	ICM
<b>A</b> Білий   White	<b>1001</b>
<b>B</b> Чорний   Black	<b>1002</b>
<b>C</b> Жовтий   Deep Yellow	<b>1003</b>
<b>D</b> Алюміній   Aluminium	<b>1023</b>
<b>E</b> Срібло   Silver	<b>1024</b>
<b>F</b> Сталь   Natural Steel	<b>1025</b>
<b>G</b> Масляна сталь   Oily Steel	<b>1026</b>
<b>H</b> Збройовий метал   Gun metal	<b>1027</b>
<b>J</b> Червоний   Deep Red	<b>1007</b>
<b>K</b> Біло-сірий   White Grey	<b>1029</b>
<b>L</b> Темно-морський сірий   Dark Sea Grey	<b>1034</b>
<b>M</b> Гумовий чорний   Rubber Black	<b>1039</b>
<b>N</b> Оливковий   Olive Green	<b>1068</b>
<b>P</b> Камуфляжний   Camouflage Green	<b>1071</b>
<b>Q</b> US Темно-зелений   US Dark Green	<b>1072</b>

COLOR	ICM
<b>R</b> Блідо-синій   Pale Blue	<b>1074</b>
<b>S</b> Напівпрозорий червоний   Clear Red	<b>1011</b>
<b>T</b> Напівпрозорий зелений   Clear Green	<b>1014</b>
<b>U</b> Нейтральний сірий   Neutral Grey	<b>1036</b>
<b>W</b> Напівпрозорий помаранчевий   Clear Orange	<b>1016</b>
<b>X</b> Буйволова шкіра   Buff	<b>1041</b>

Для отримання глянцевого, сатинового чи матового ефекту – використовуйте наші лаки!

For a glossy, satin or matte effect – use our varnishes!

**01** СТАДІЯ СКЛАДАННЯ  
ASSEMBLY STEP

**A** ФАРБА, ЩО ВИКОРИСТОВУЄТЬСЯ  
USED COLOR

**x2** ЗРОБИТИ ДВІ ДЕТАЛІ  
MAKE 2 PCS

**NE** НЕ КЛЕЇТИ  
DO NOT CEMENT

**03** СКЛАДАЛЬНА ОДИНИЦЯ  
ASSEMBLY UNIT

**\*** ЗРОБИТИ САМОМУ  
SCRATCH BUILD

**H** ПРОСВЕРДЛИТИ  
OPEN HOLE

**C** ВІДРІЗАТИ  
CUT OFF

У В А Г А І С А У Т І О Н І

Перед складанням уважно прочитати інструкцію з монтажу. Кожна деталь пронумерована. Дотримуватися послідовності монтажу. Необхідні робочі інструменти: ніж і напилек для зачистки деталей, гумова стрічка, клеюча стрічка і прищипки для білини (для припинення склеюваних деталей). Деталі з пластику очистити в розчині м'якого миючого засобу і висушити на повітрі для того, щоб фарба і перевірни картички краще прилипали. Перед приклеюванням перевірити, чи підходять деталі; клей наносити економно. Хром і фарбу видаляти з поверхонь склеювання. Невеликі деталі пофарбувати перед тим, як вони будуть вдалені з рамок. Фарбу необхідно добре просушити, тільки після цього продовжувати складання. Кожну відповідну перевірку картки вирізати окремо і приблизно на 20 секунд занурити в теплу воду. На позначеному місці картинку відокремити від паперу і приклеїти промокальним папером.

Read the instructions thoroughly prior to assembly. Each component is numbered. Adhere to specified sequence of assembly. Tools required: knife and file for removal of components from frame; rubber bond, adhesive tape and clothes pegs for clamping components together after applying adhesive. Clean plastic components in a mild detergent solution and allow to air-dry so that paint and transfers adhere better. Prior to applying adhesive, check to see whether the components fit together; apply adhesive sparingly. Remove chrome and paint from the contact surfaces. Paint small components before removing them from the frame. Allow paint to dry well, and only then continue to assemble. Cut out each transfer individually and immerse in warm water for approx. 20 seconds. Slide transfer off paper and into designated position, then press on with blotting paper.



Використовуйте набір фарб від ICM  
Best to be used with ICM Paint Set



2001  
МАТОВИЙ ЛАК  
VARNISH MATT



2002  
САТИНОВИЙ ЛАК  
VARNISH SATIN



2003  
ГЛЯНЦЕВИЙ ЛАК  
VARNISH GLOSS

Покрокова  
відеоінструкція тут



Step-by-step video  
instruction here

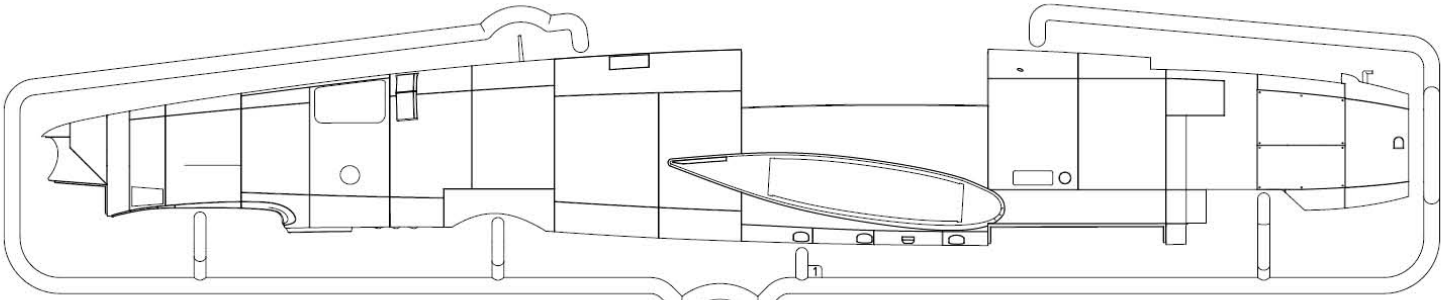

**A1**

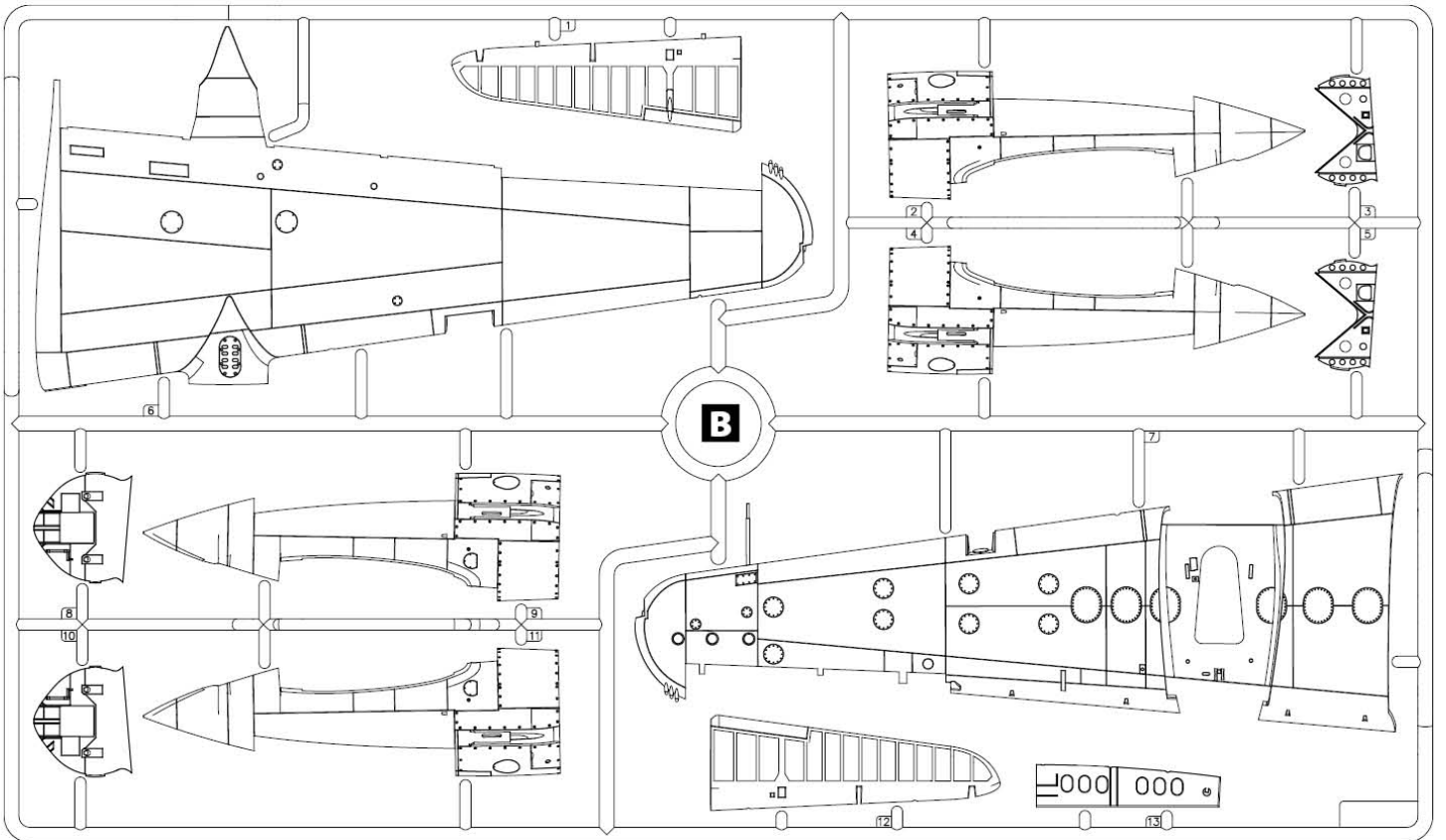
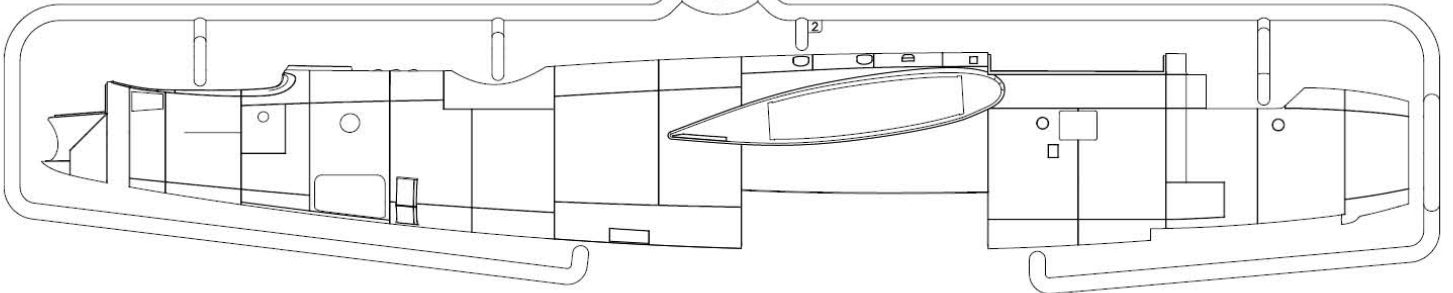

**B**

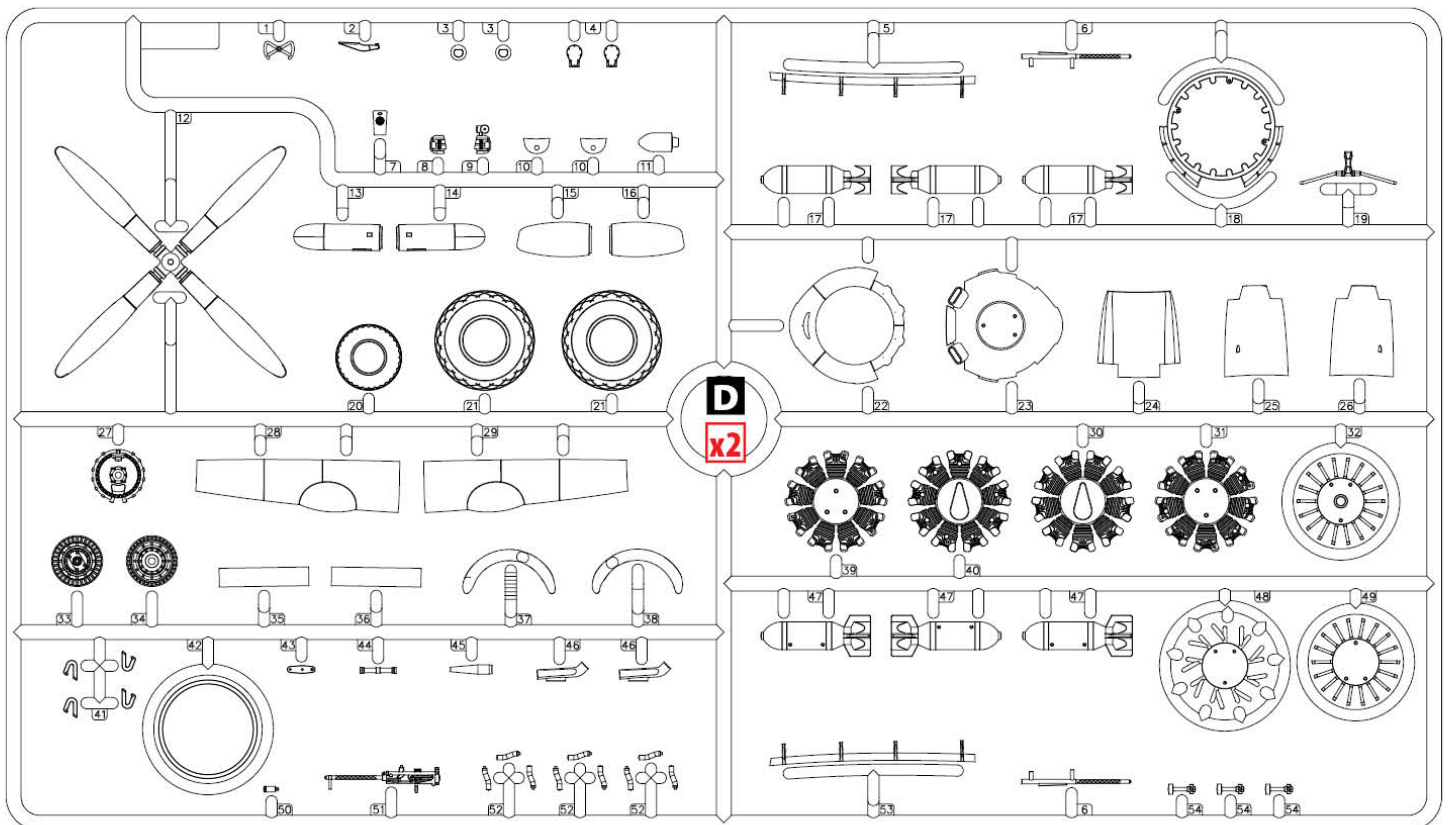
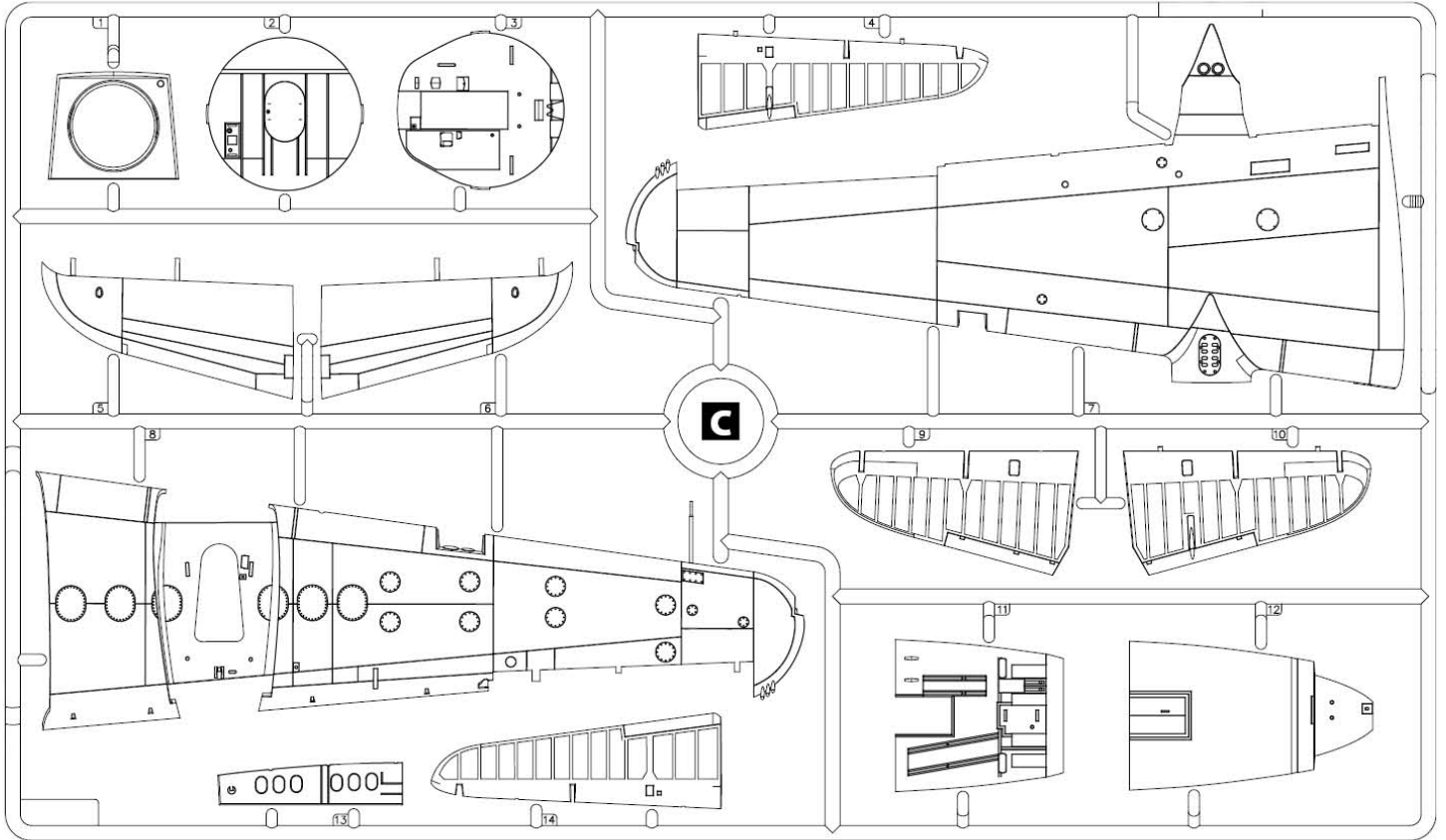

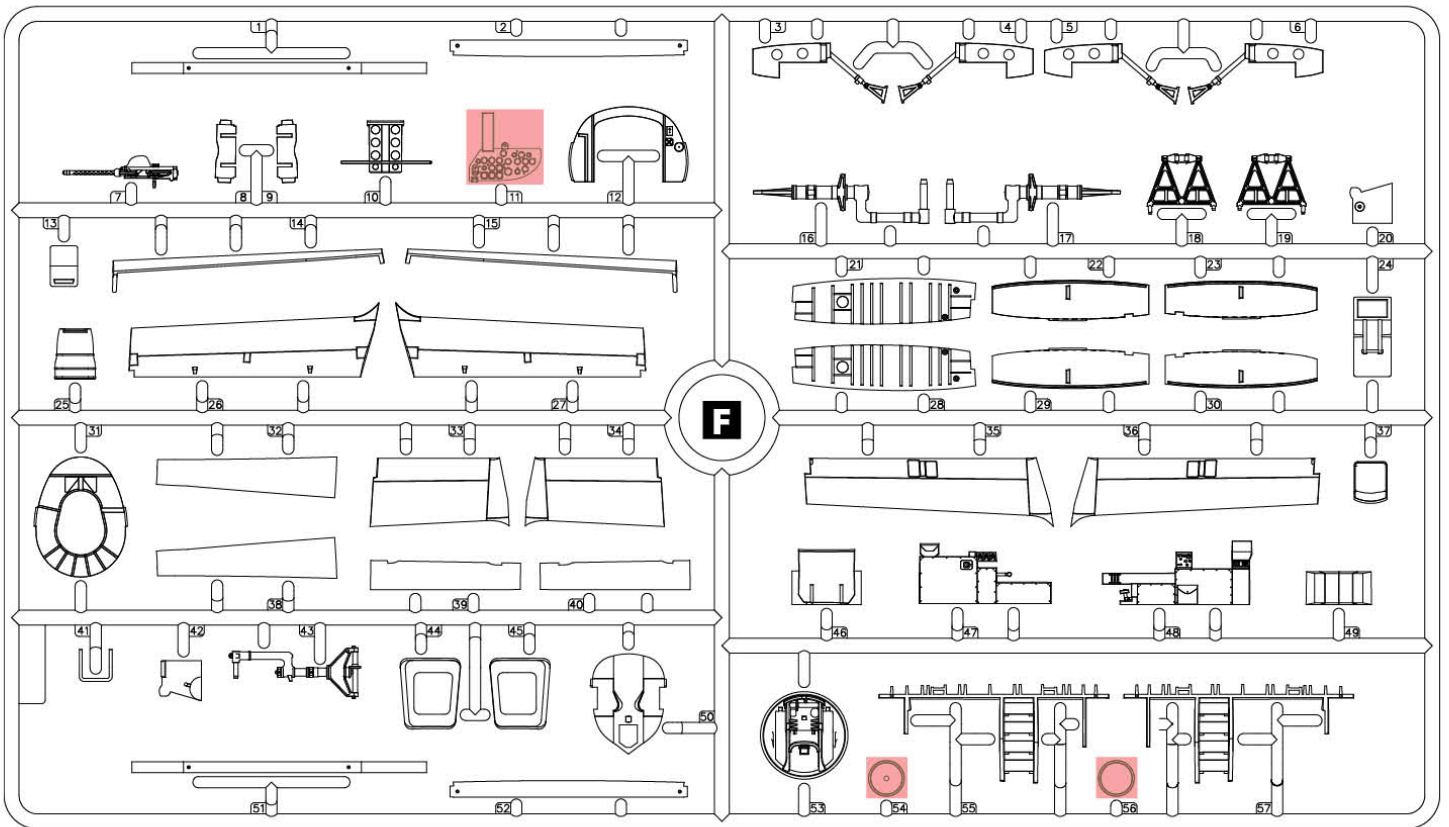
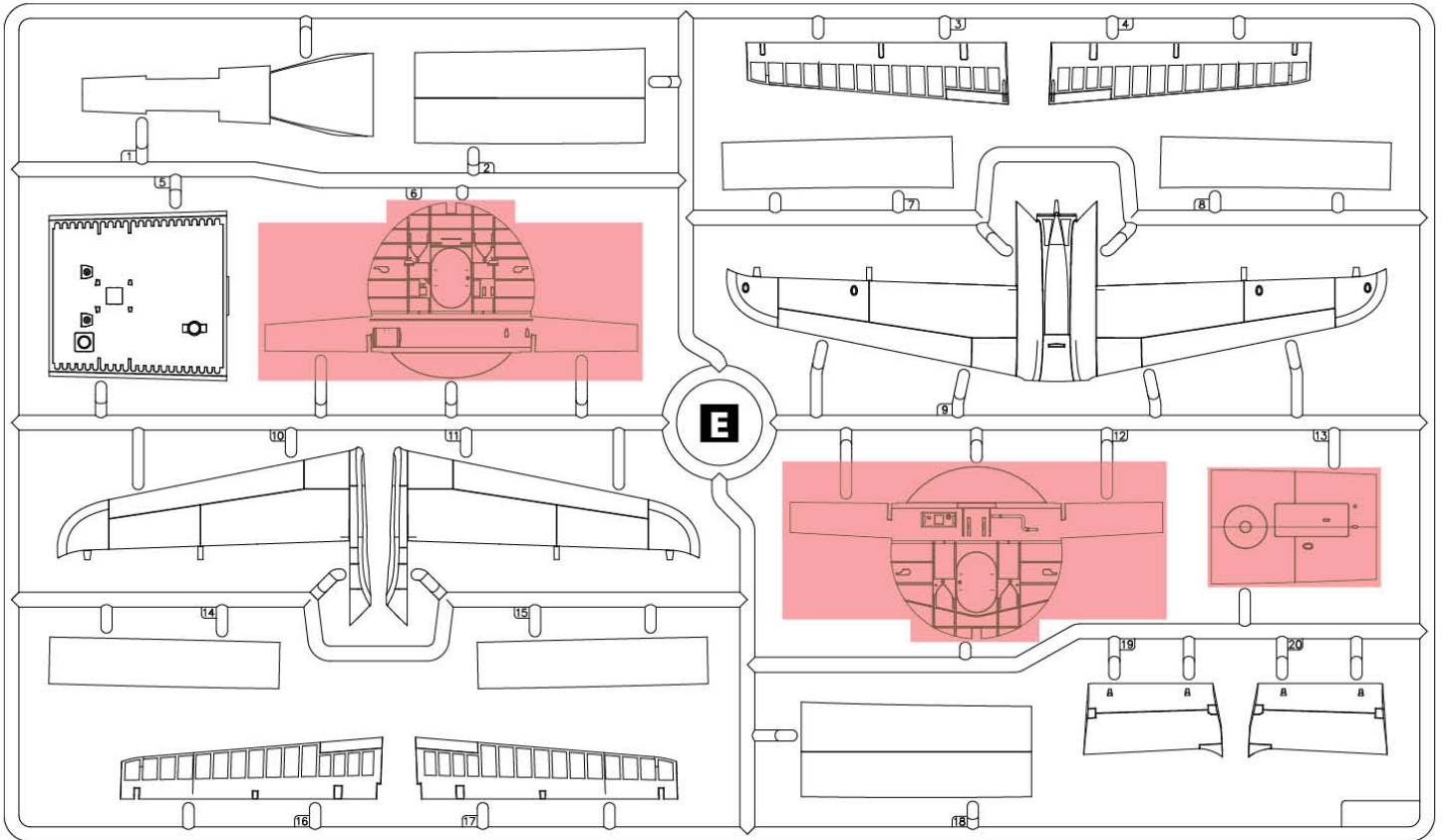

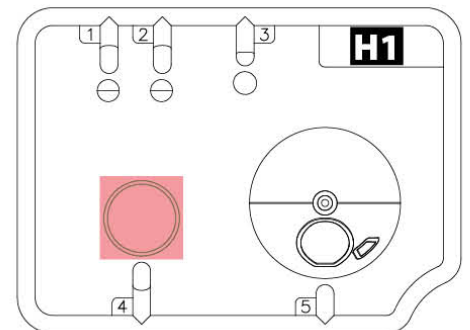
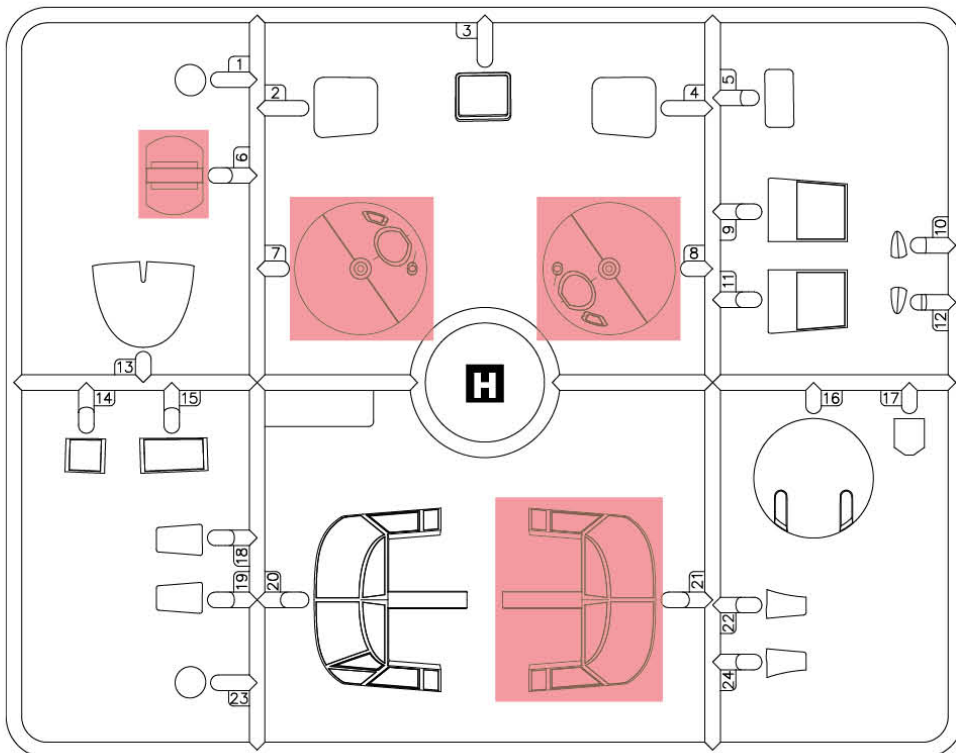
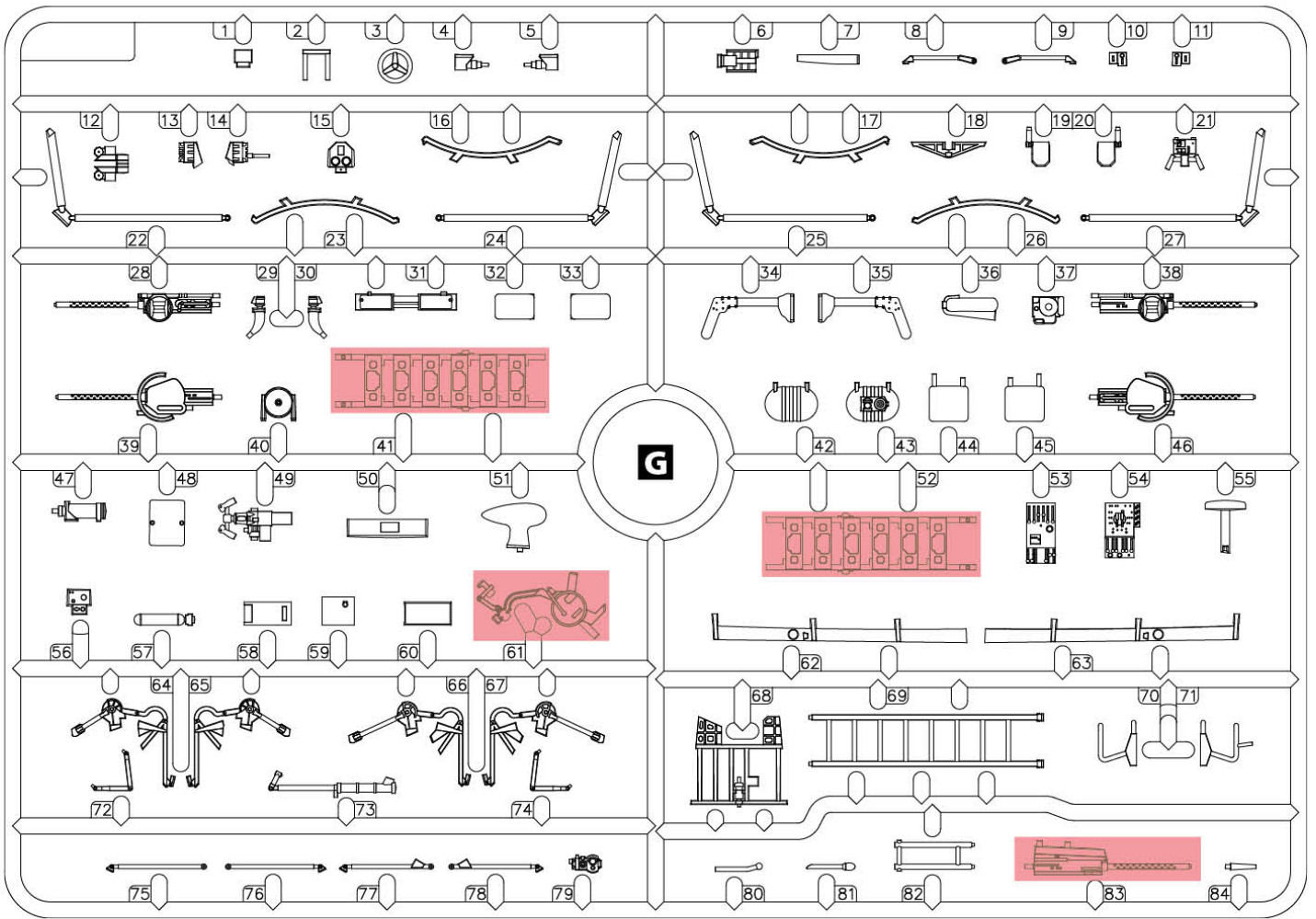

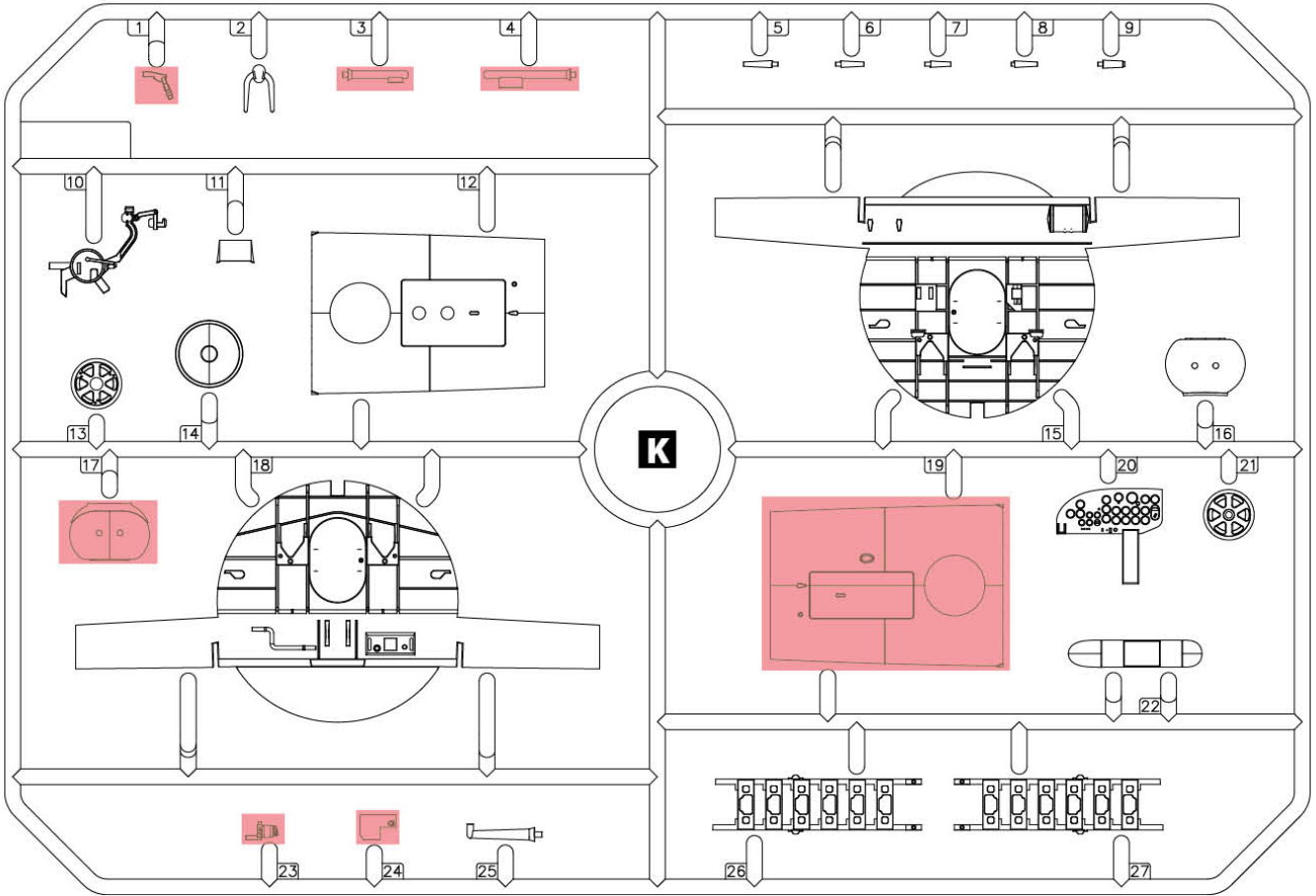

**N** УСІ ДЕТАЛІ, ОКРІМ ПОЗНАЧЕНИХ ОКРЕМО  
 ALL DETAILS EXCEPT MARKED SEPARATELY

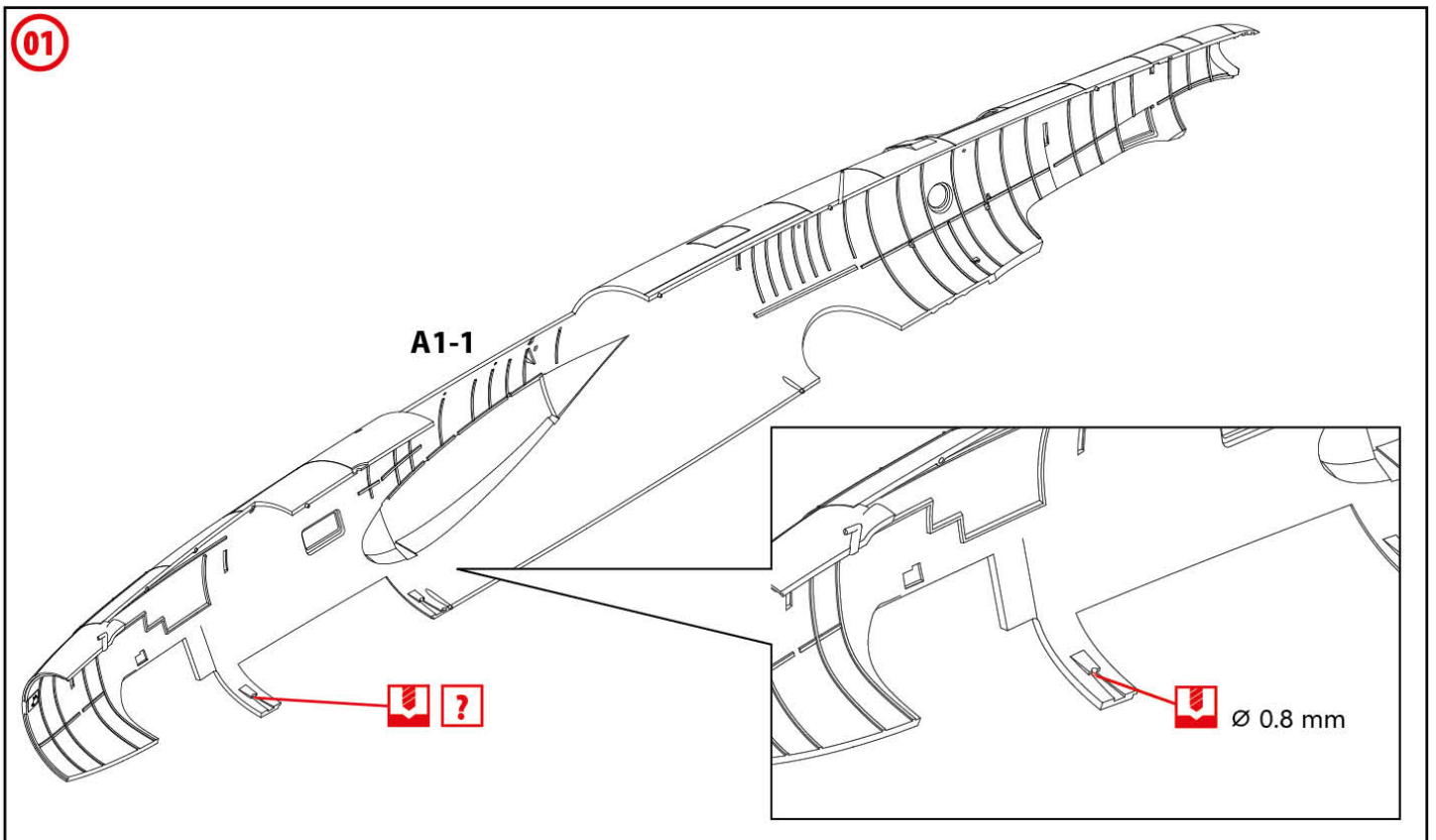

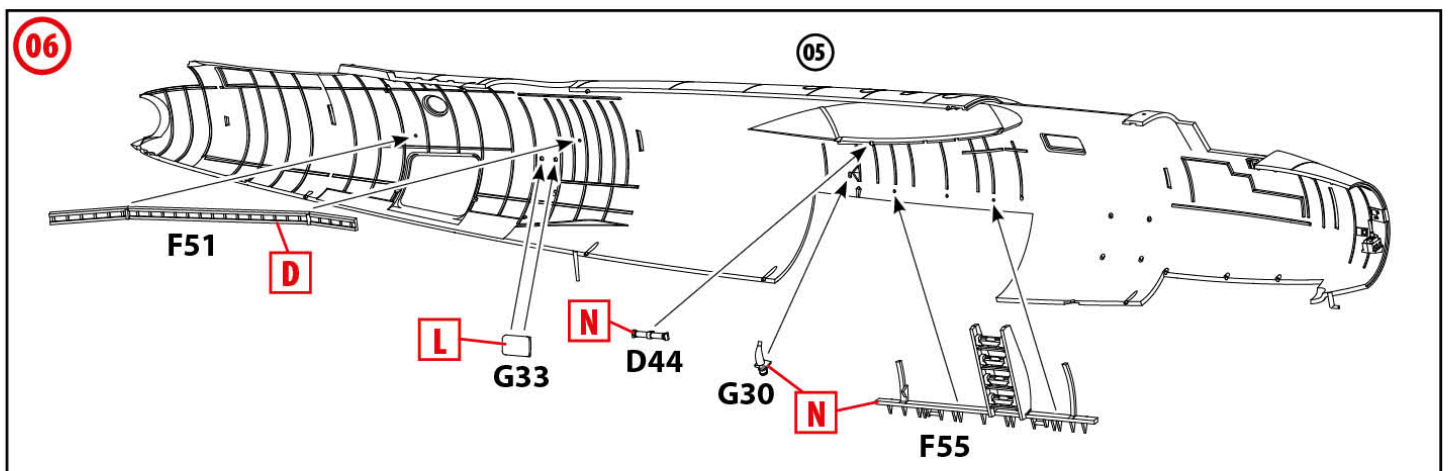
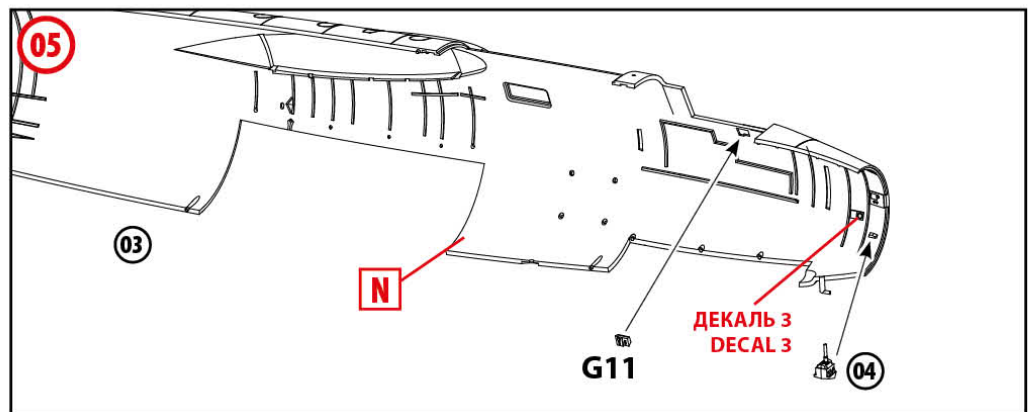
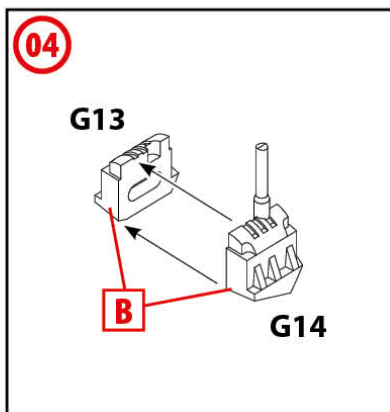
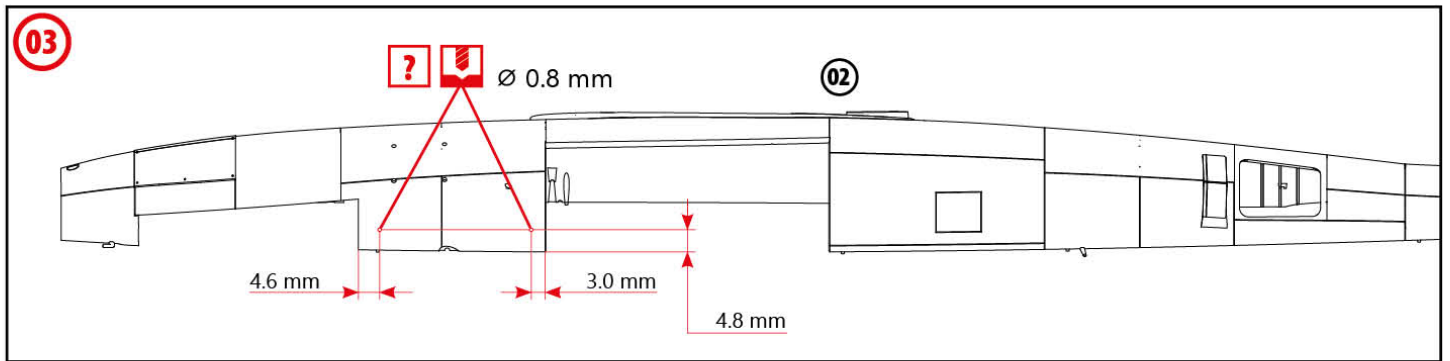
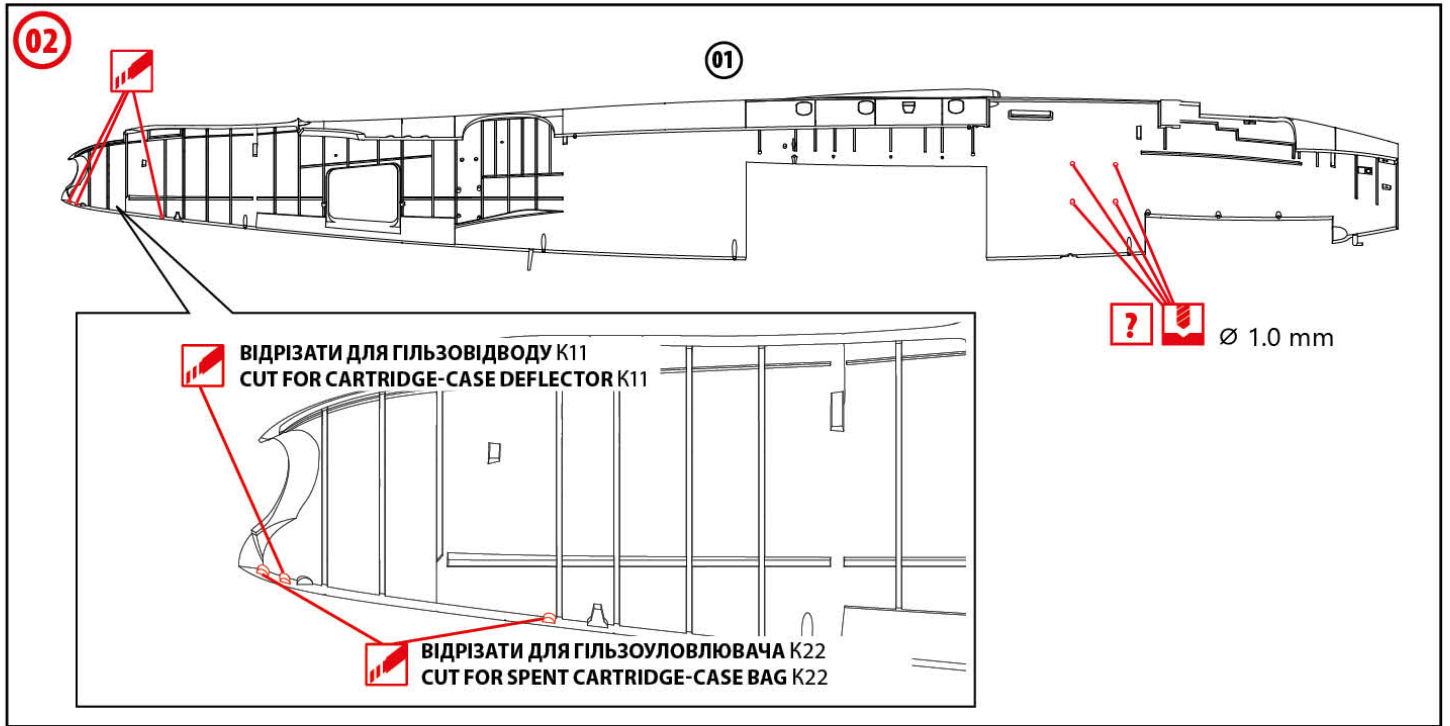

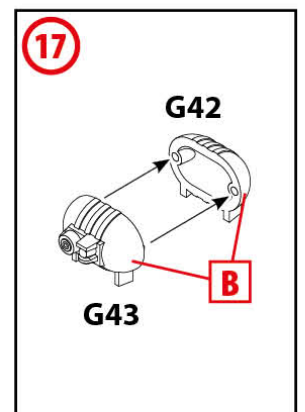
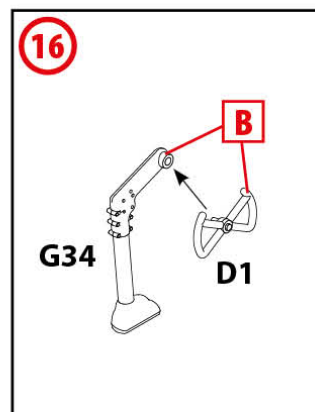
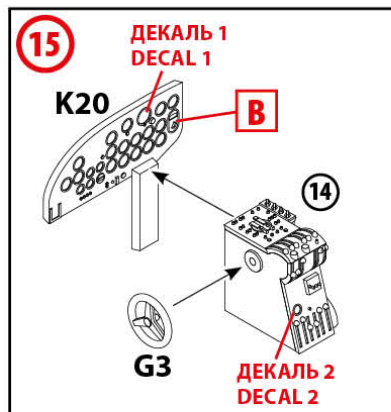
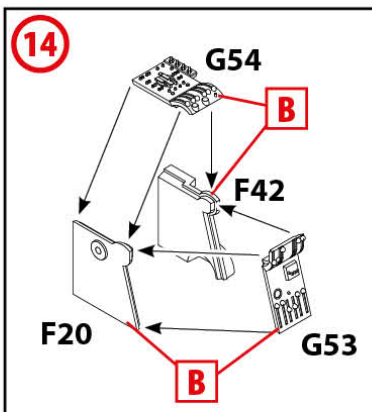
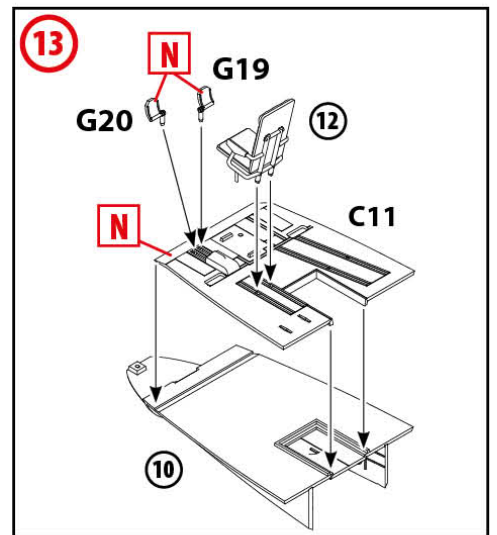
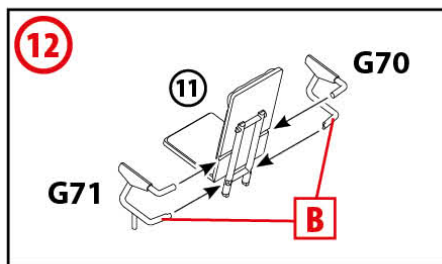
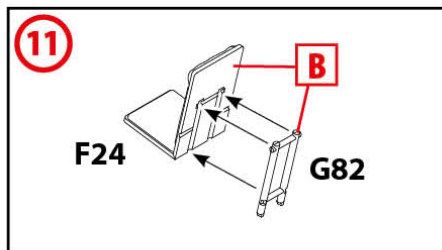
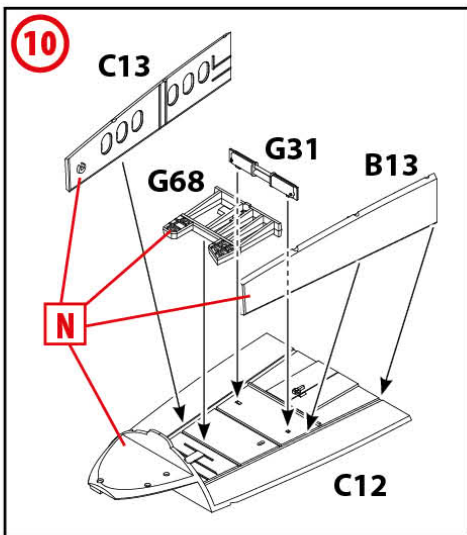
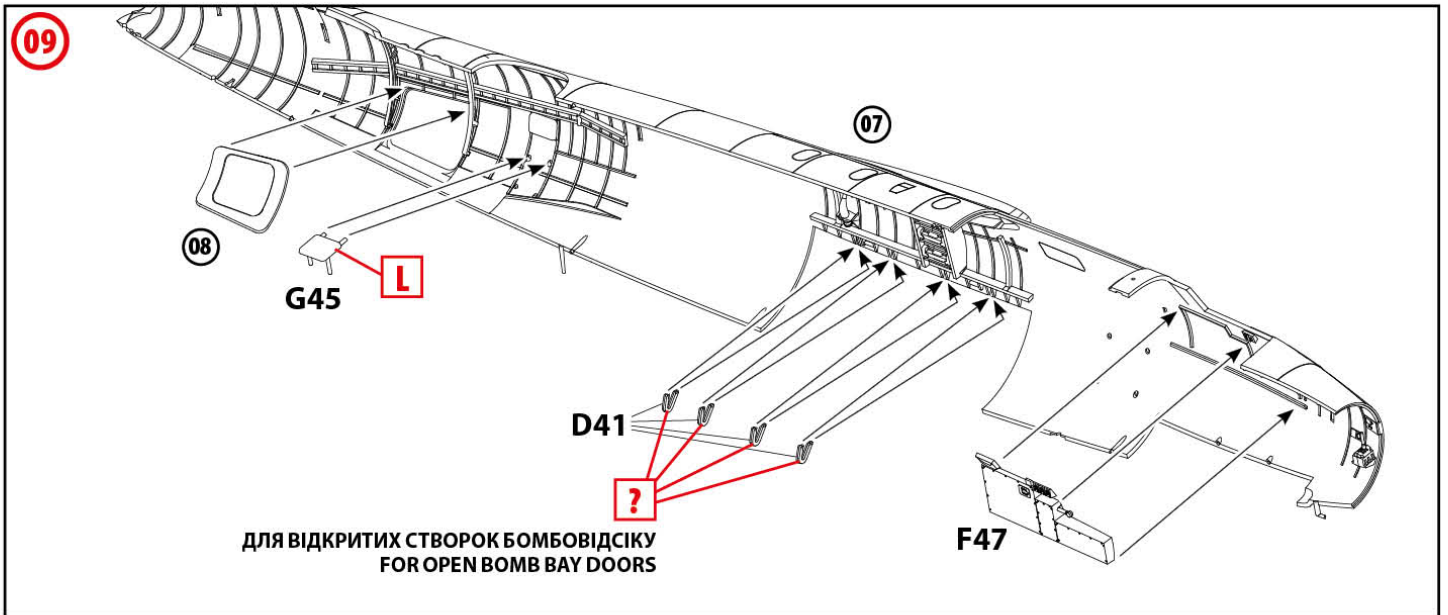
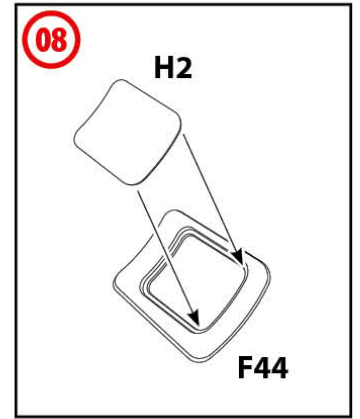
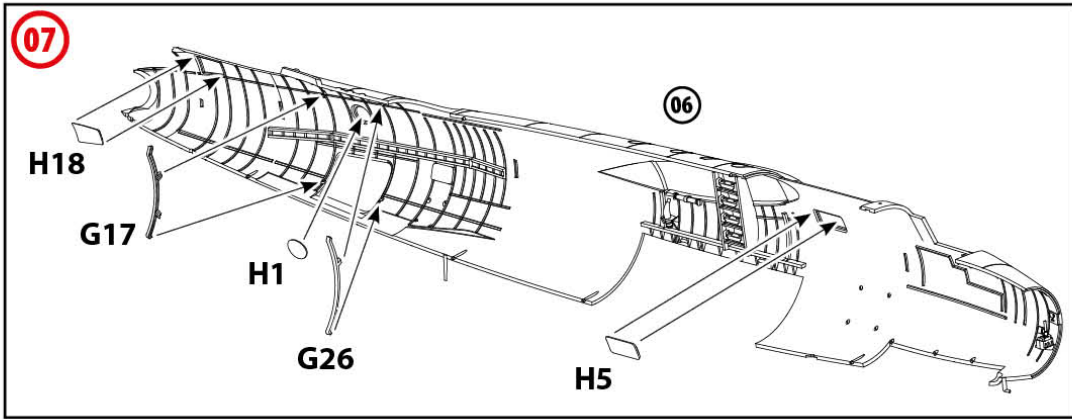



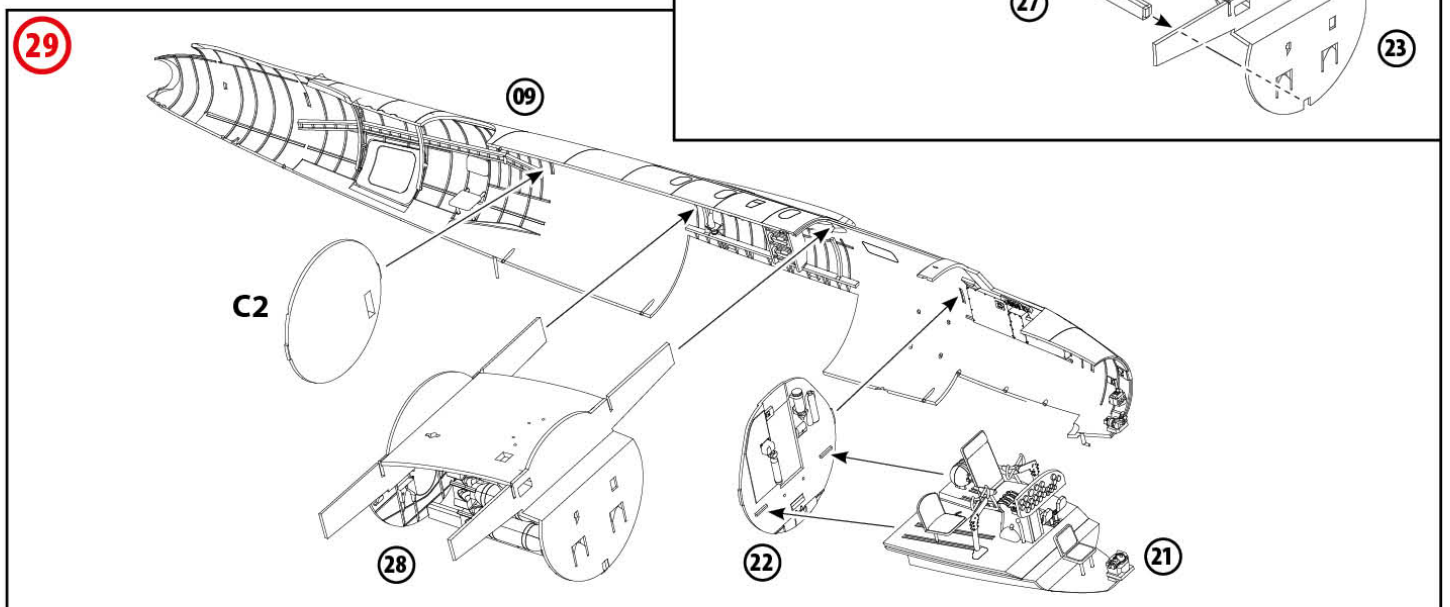
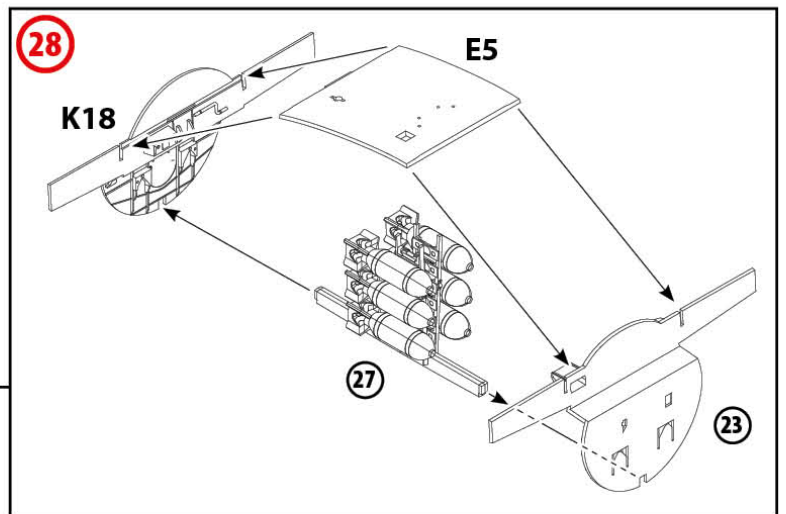
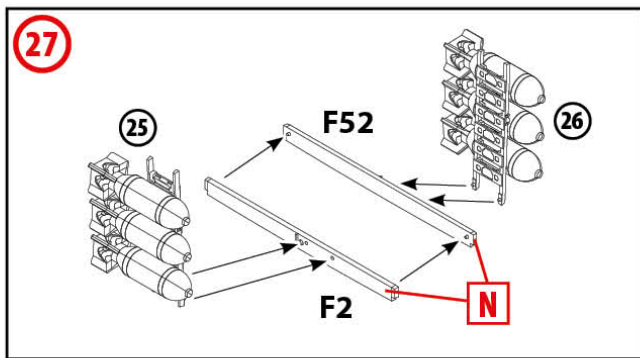
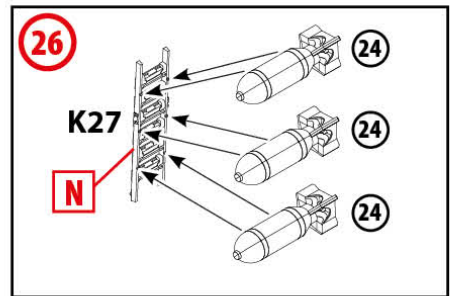
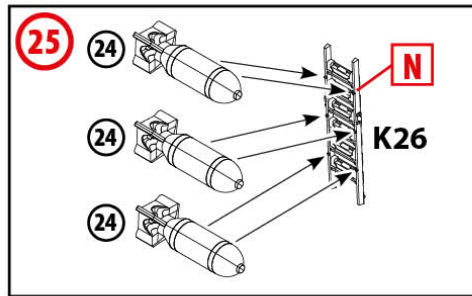
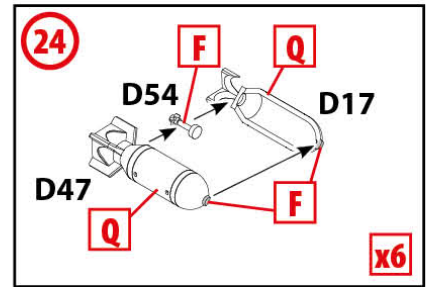
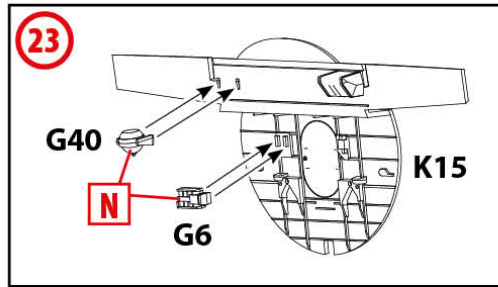
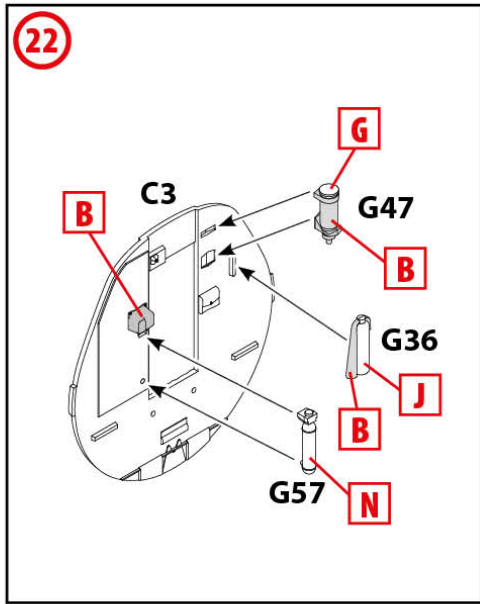
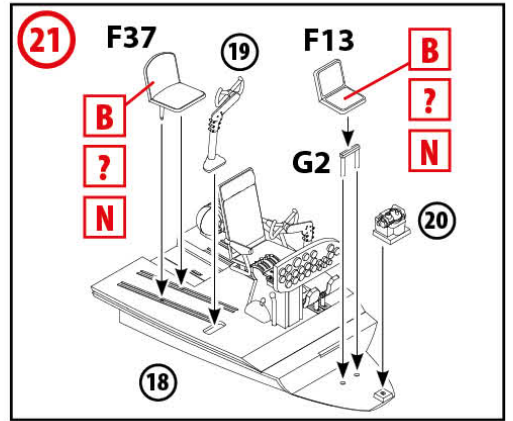
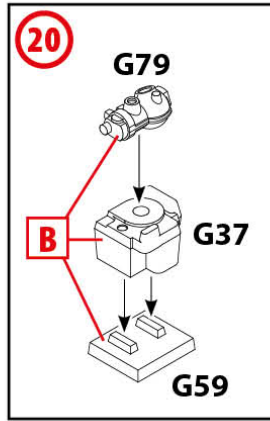
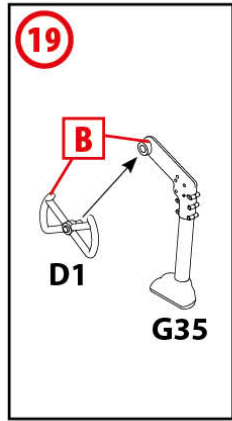
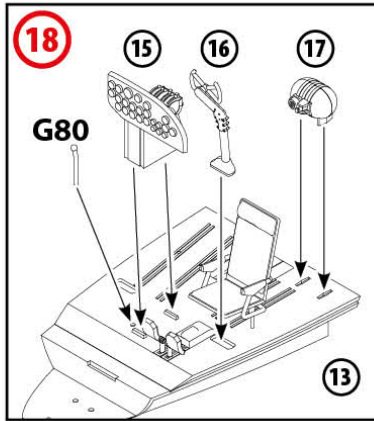

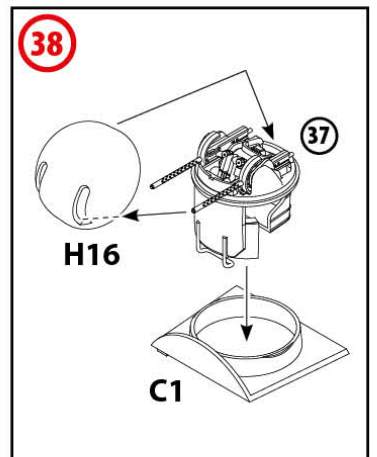
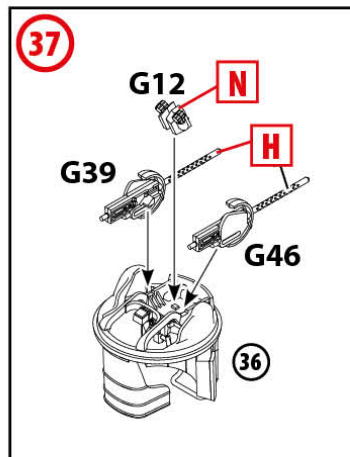
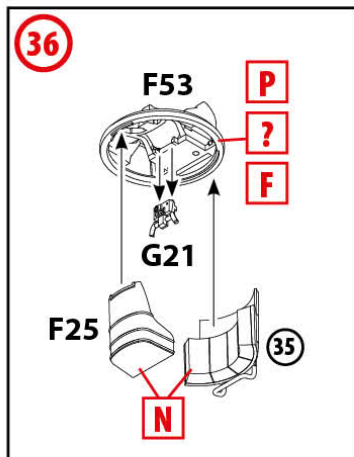
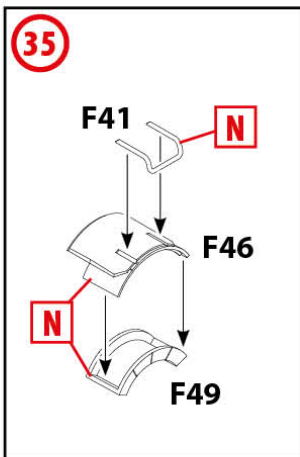
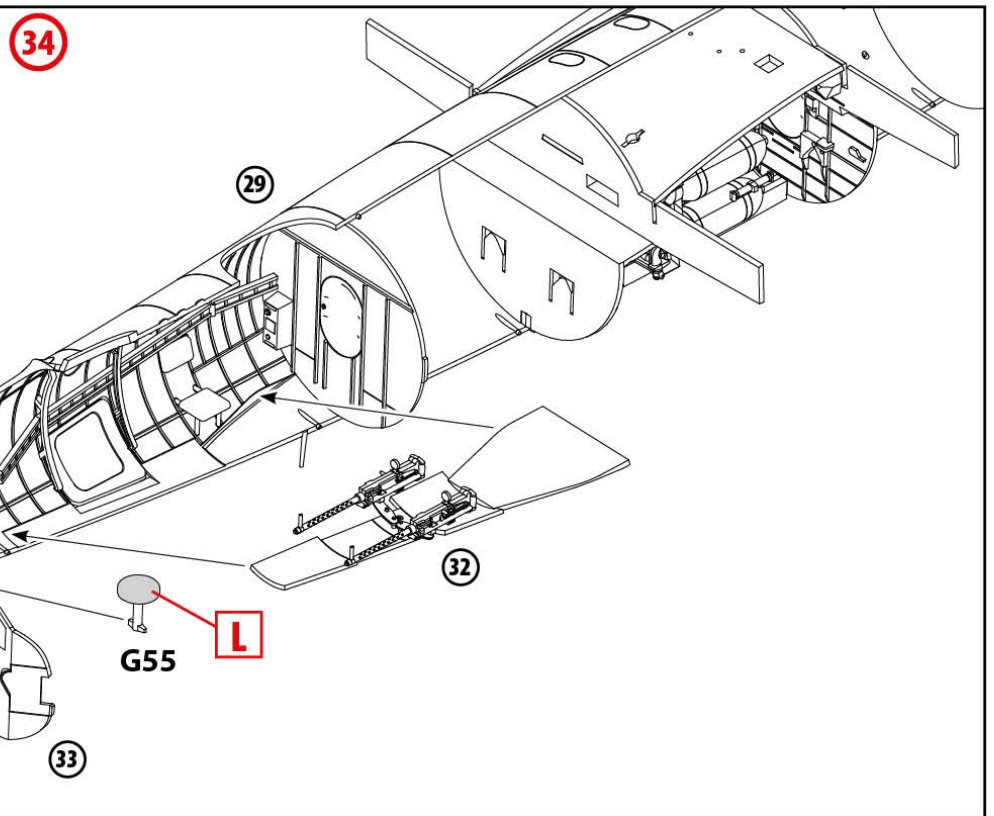
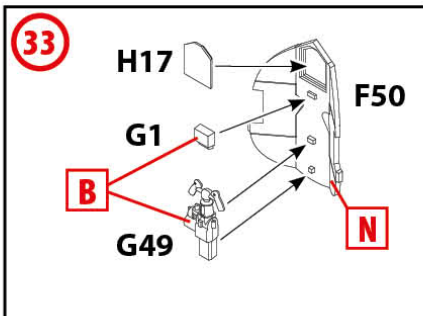
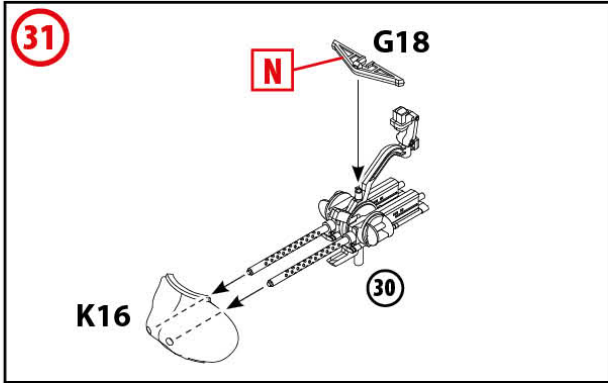
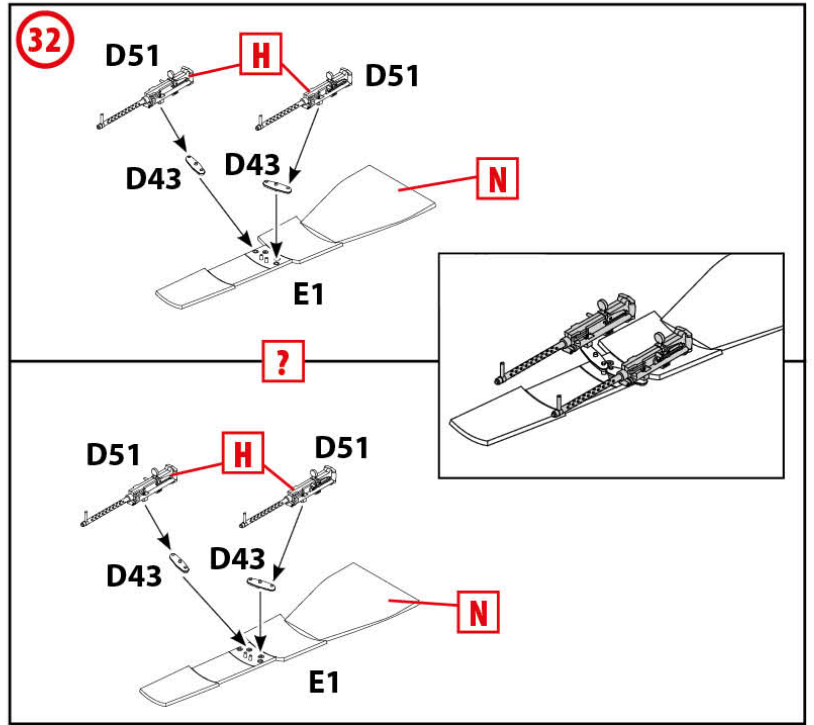
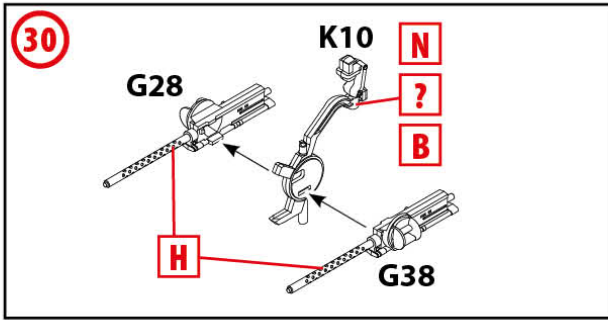

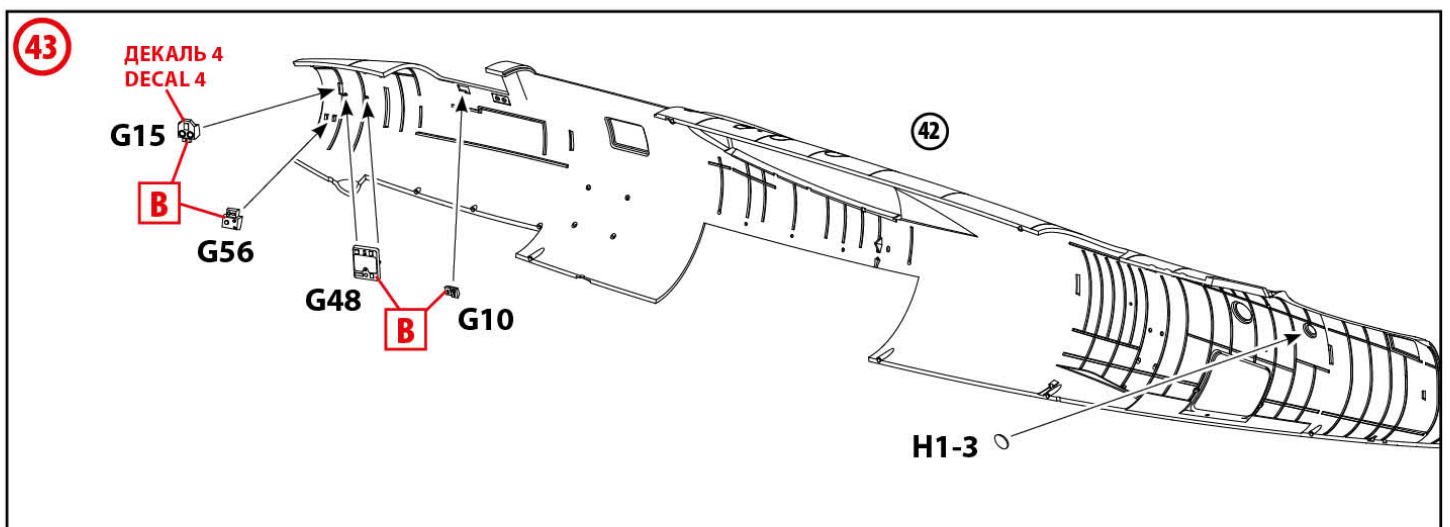
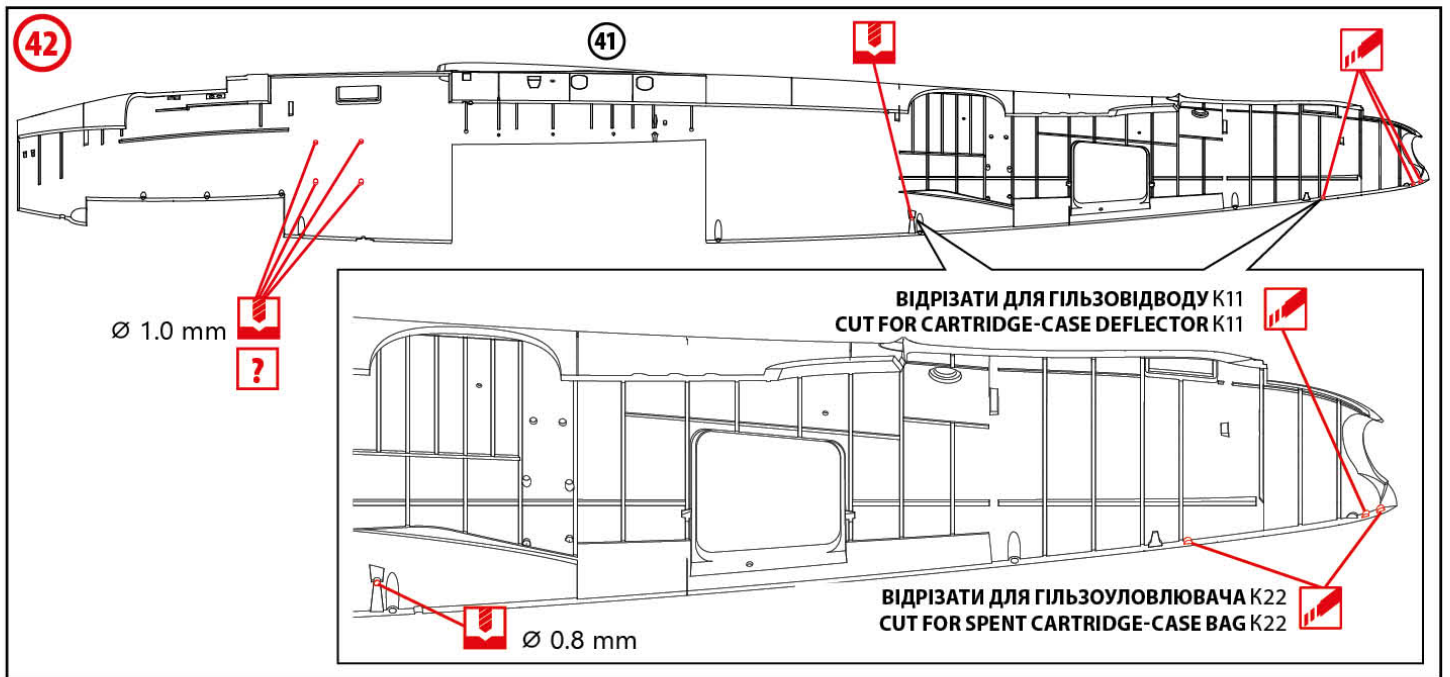
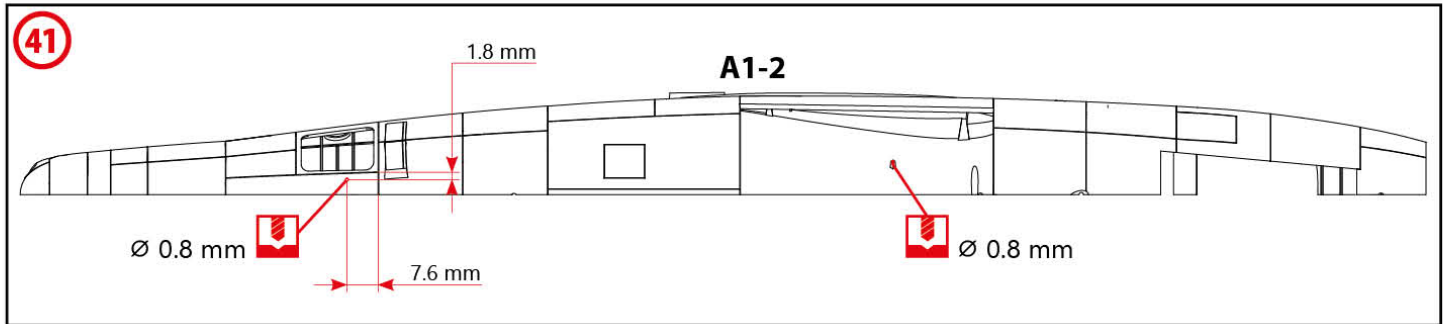
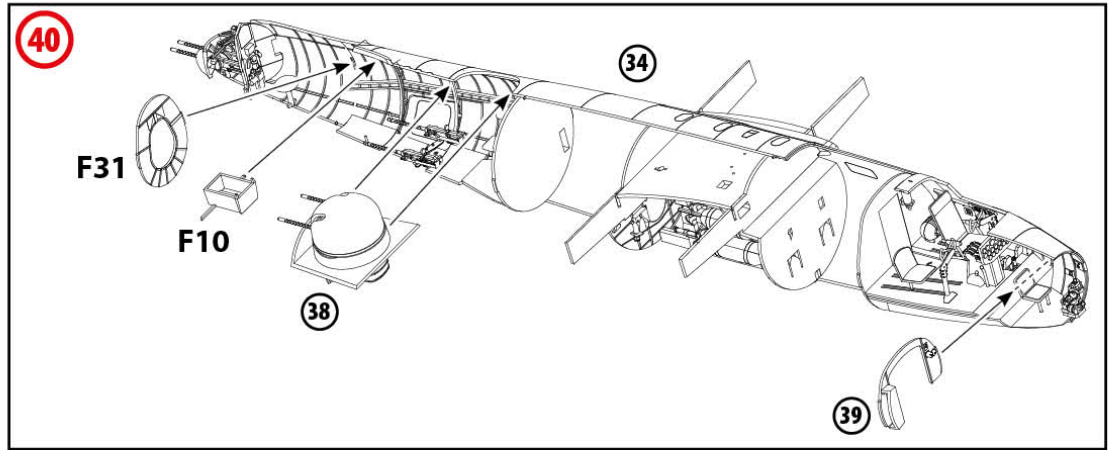
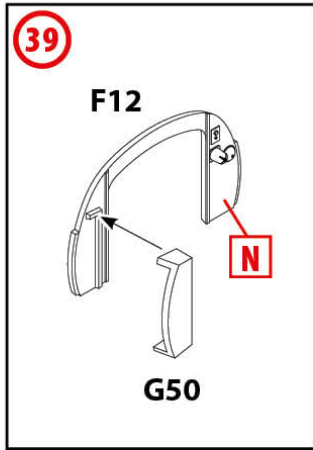

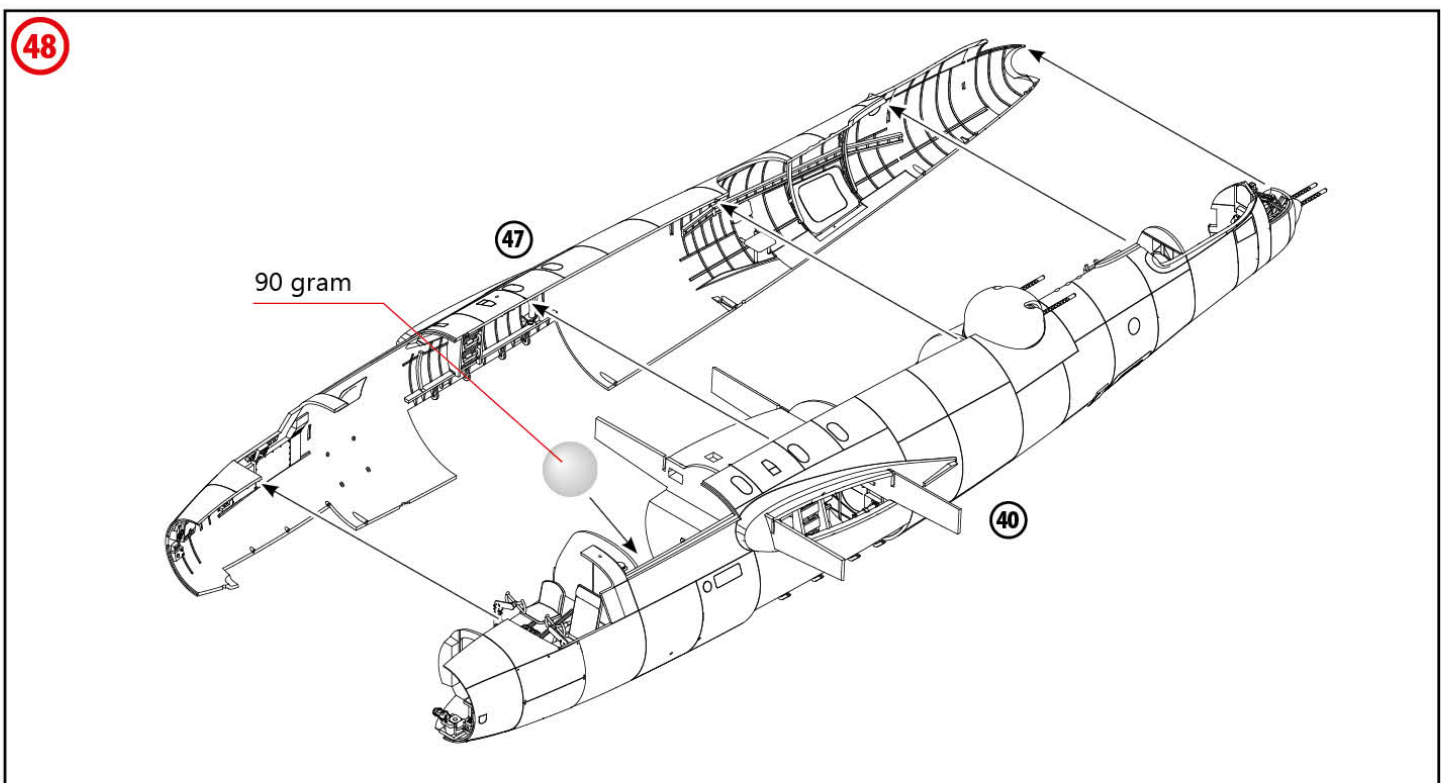
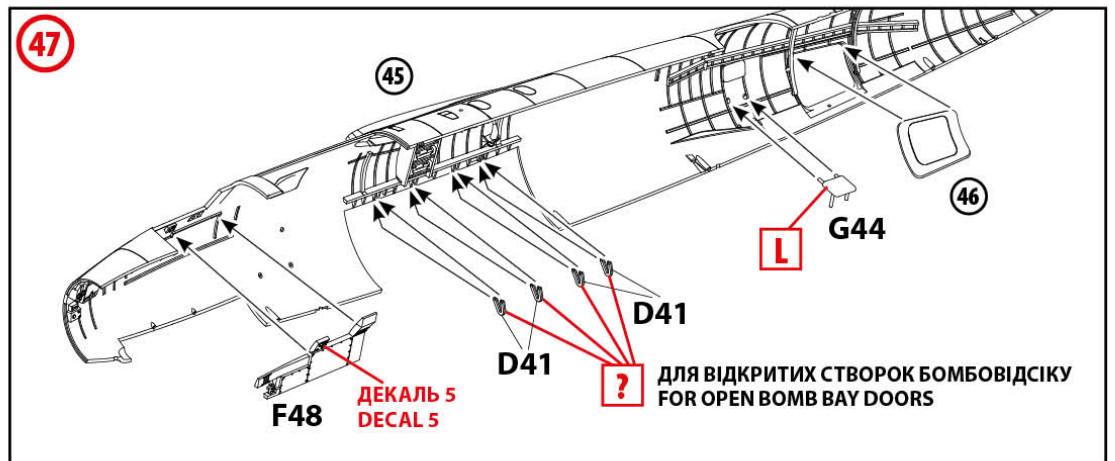
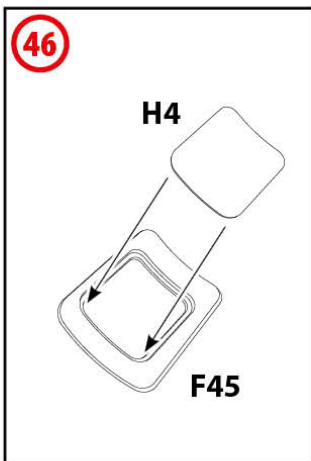
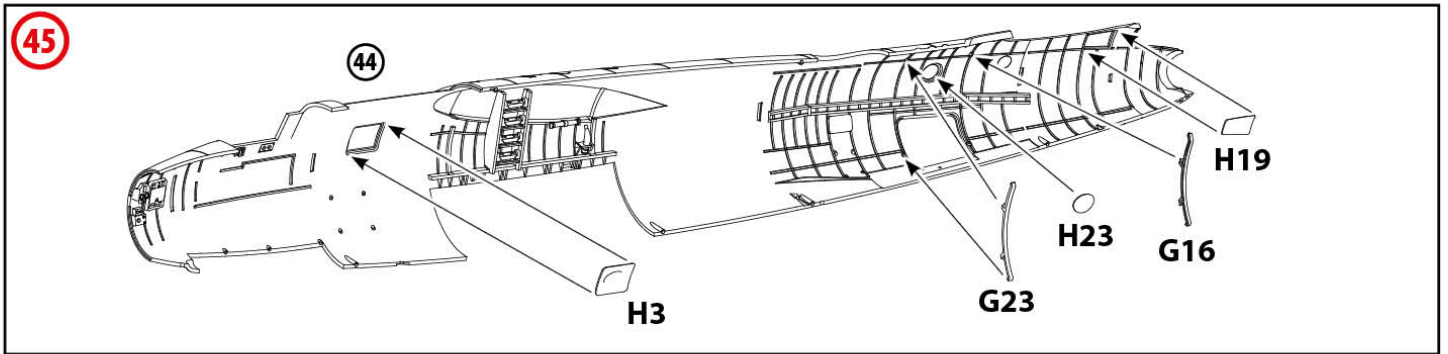
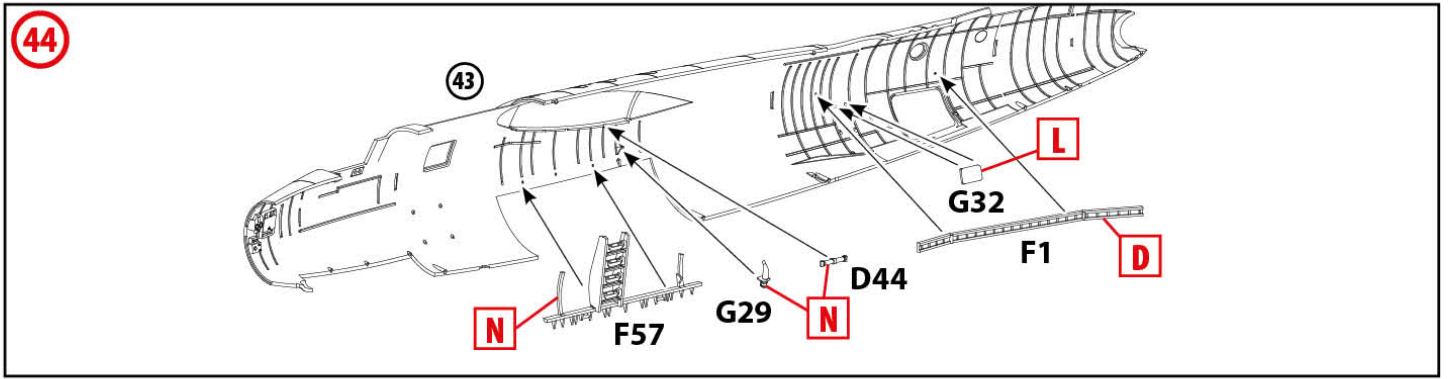

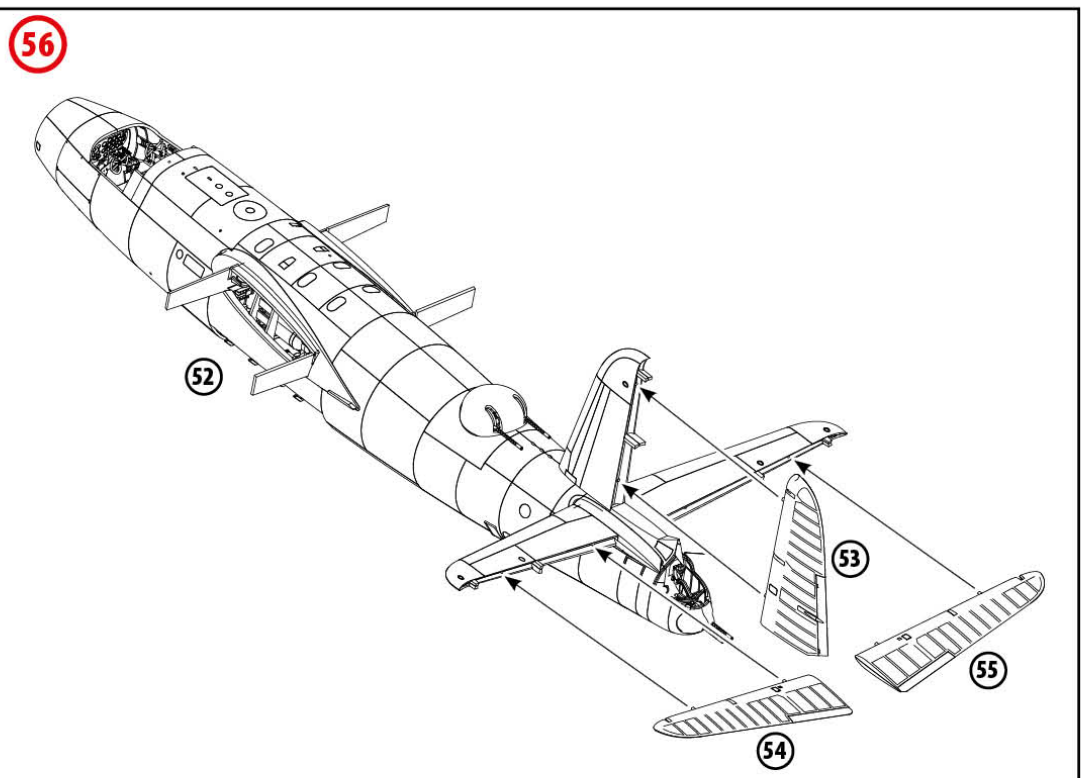
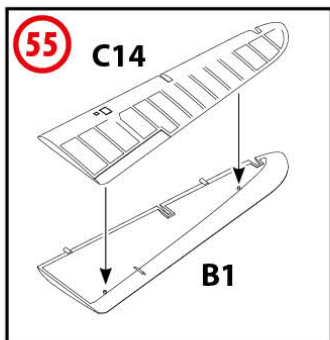
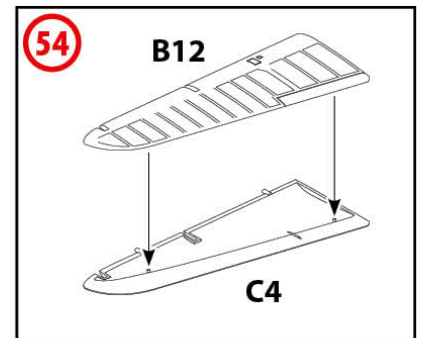
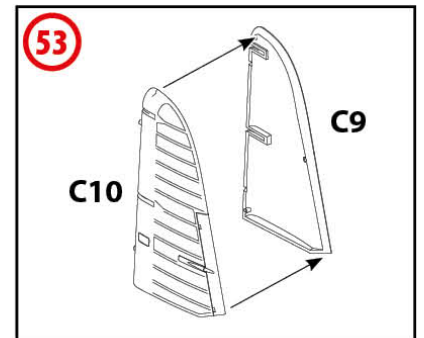
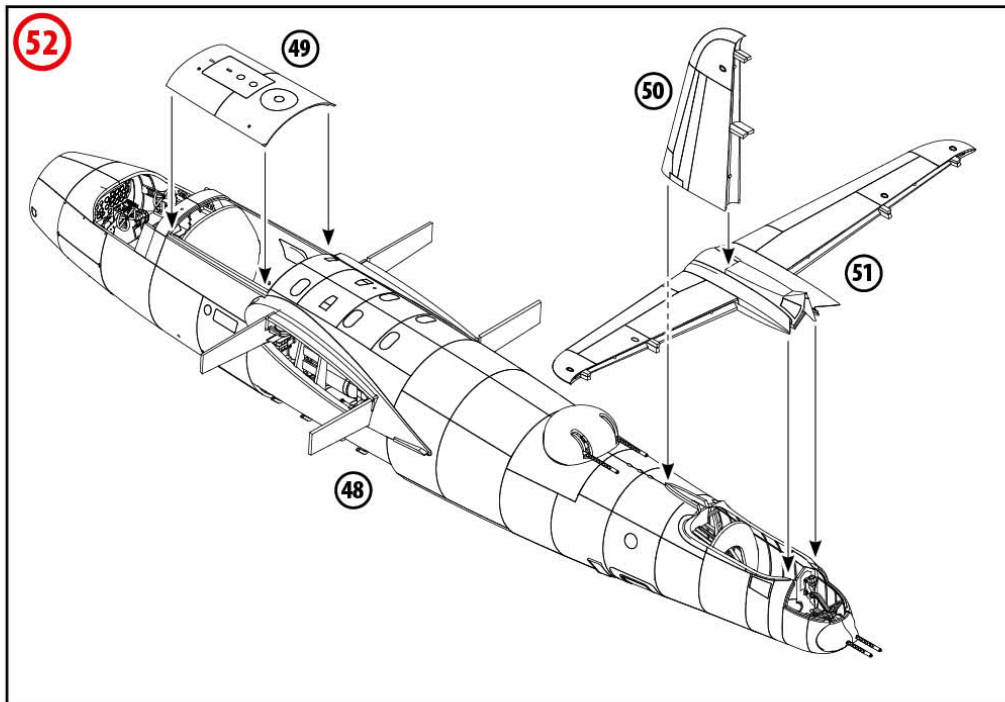
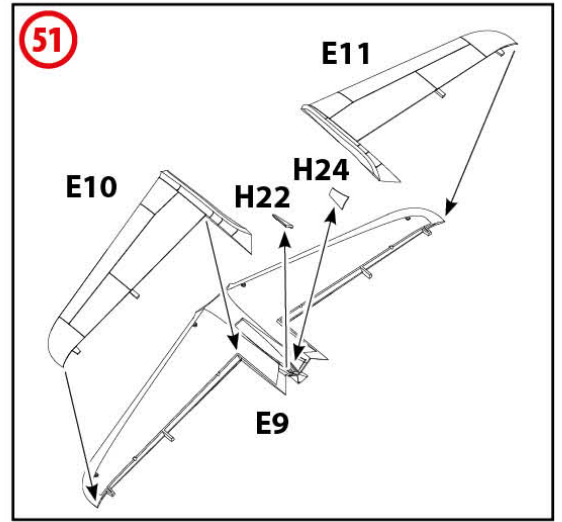
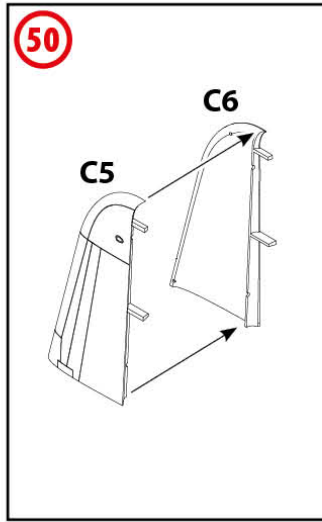
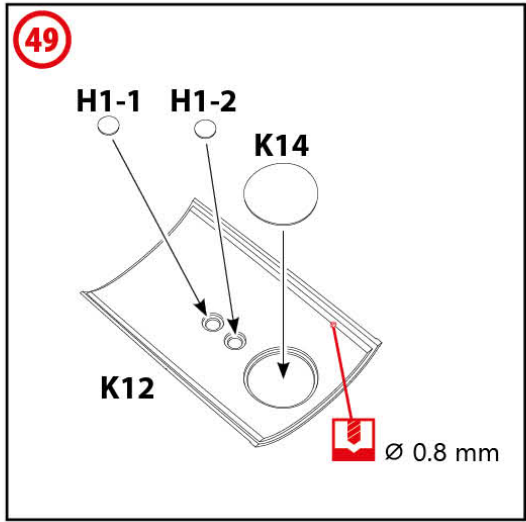

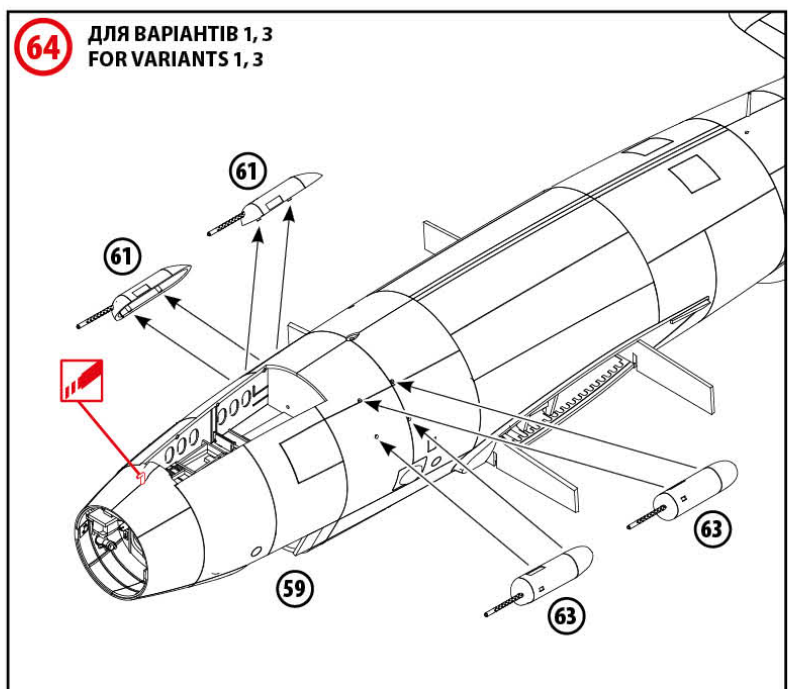
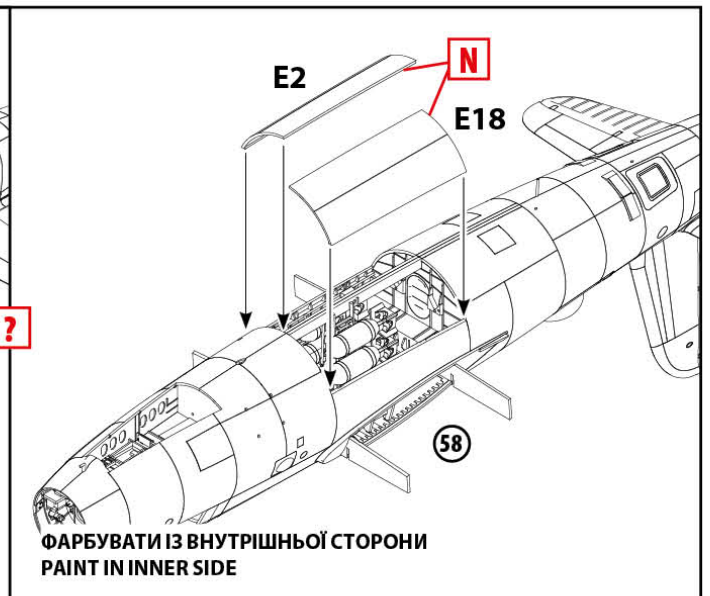
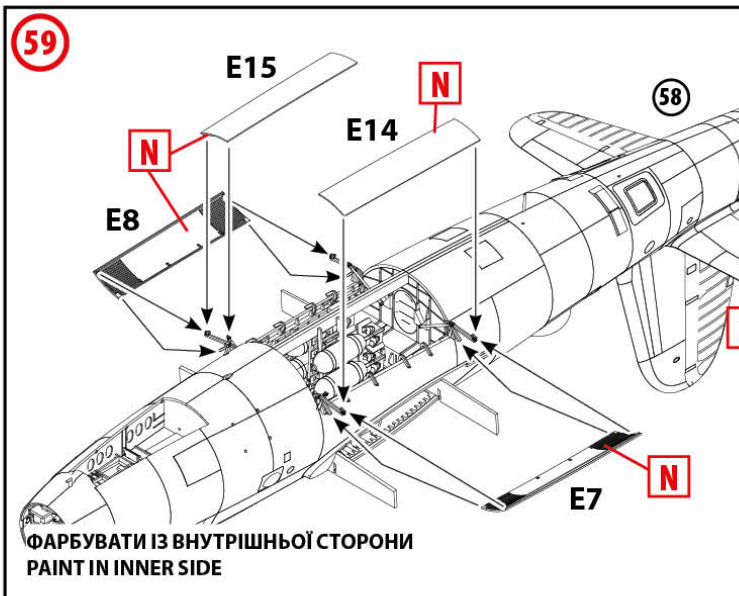
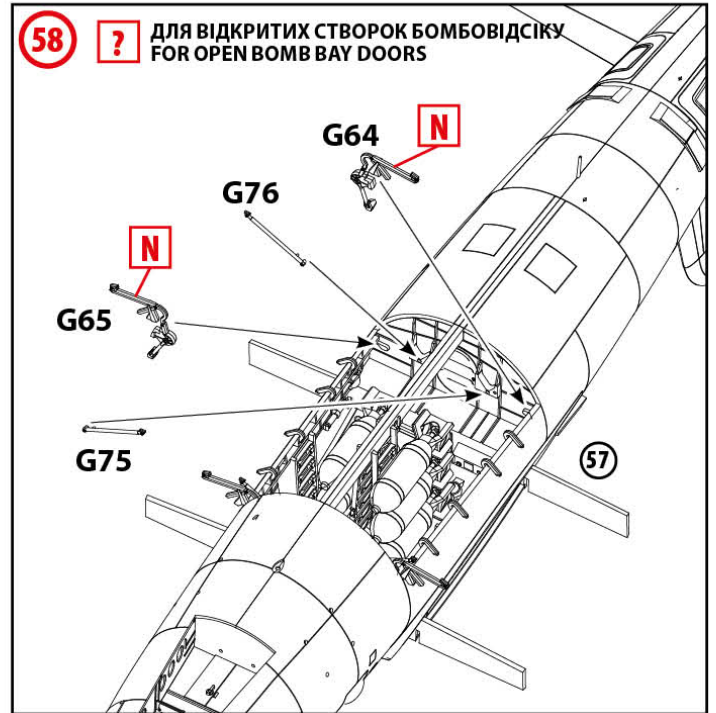
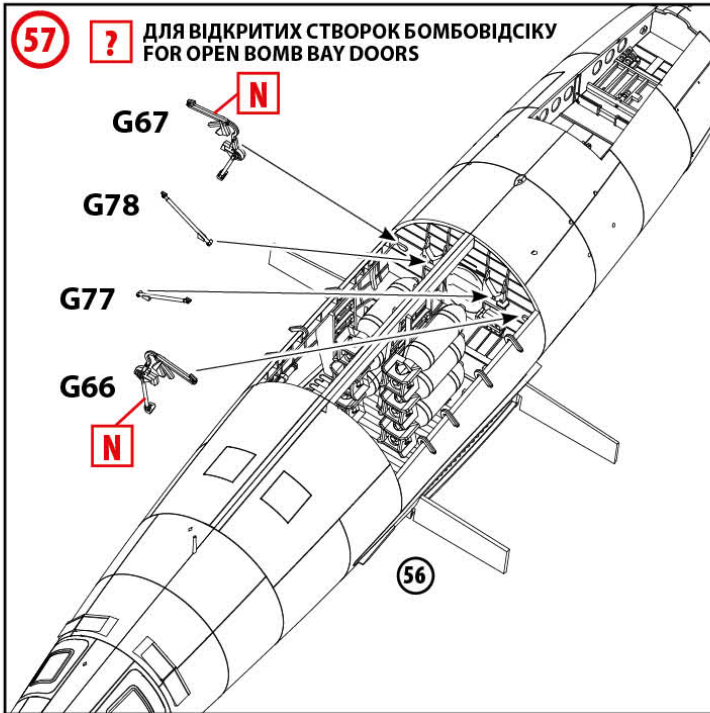

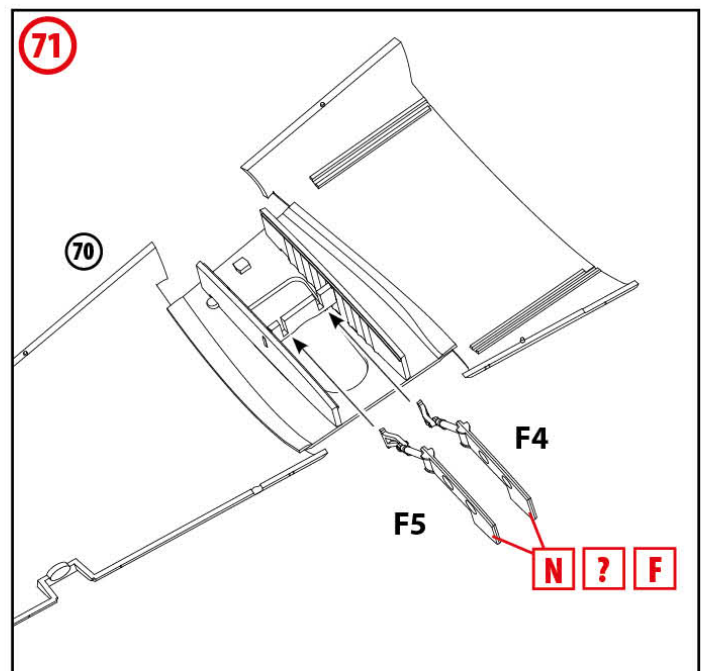
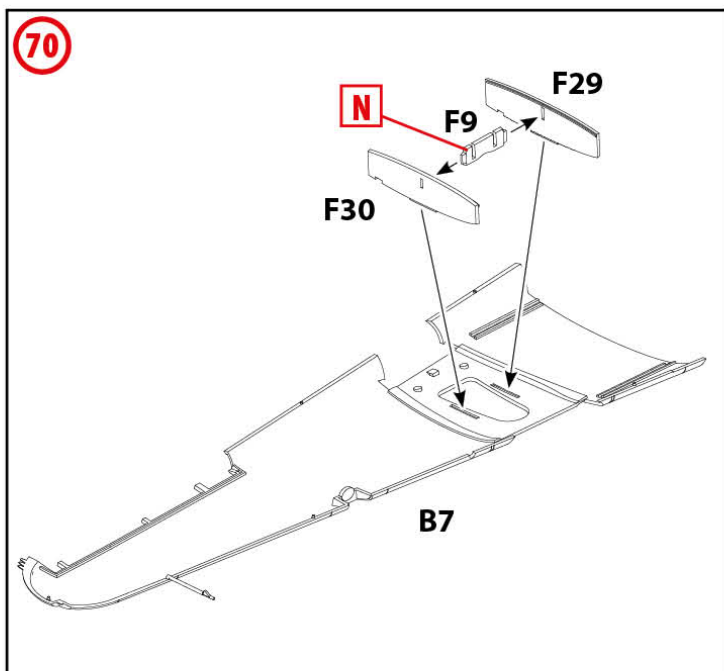
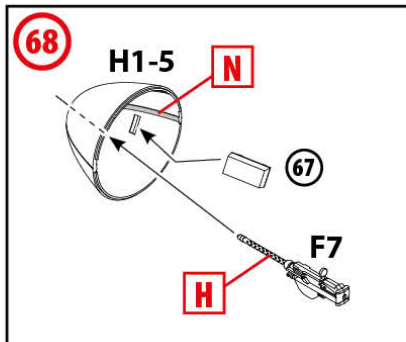
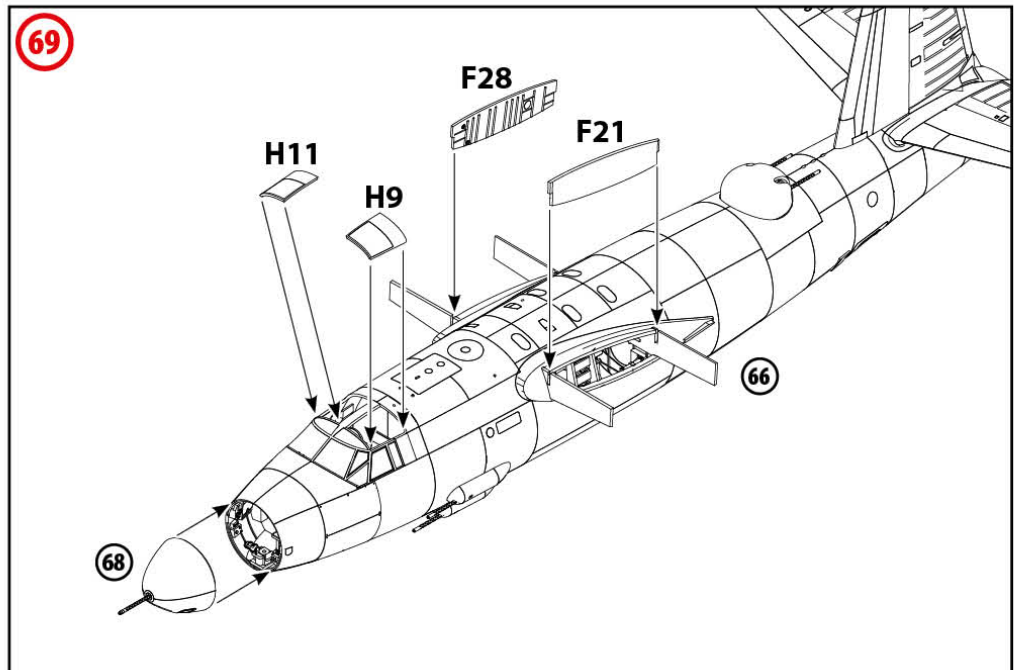
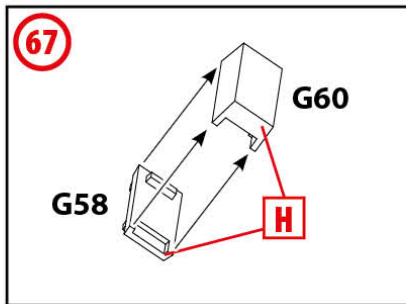
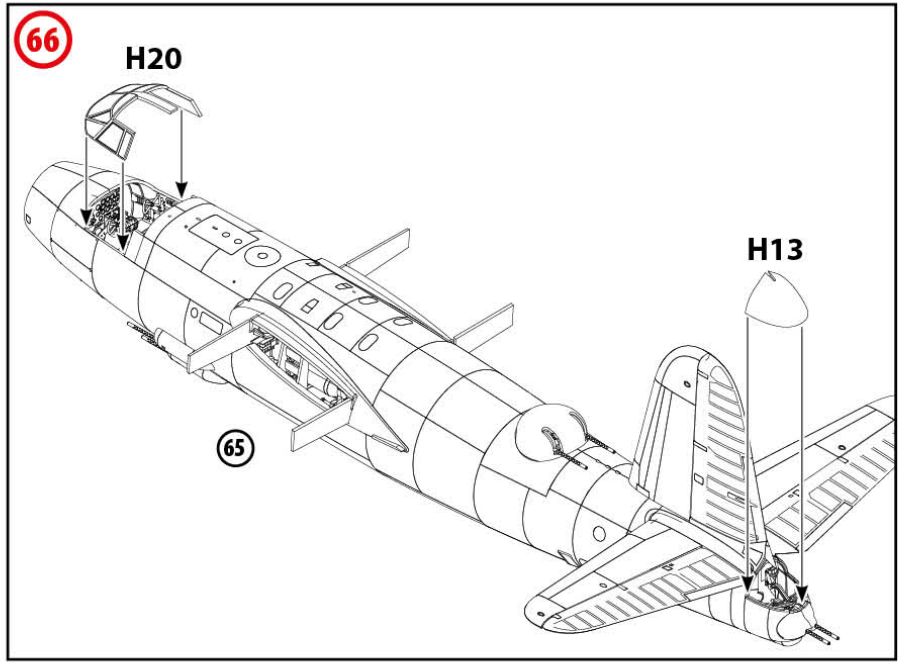
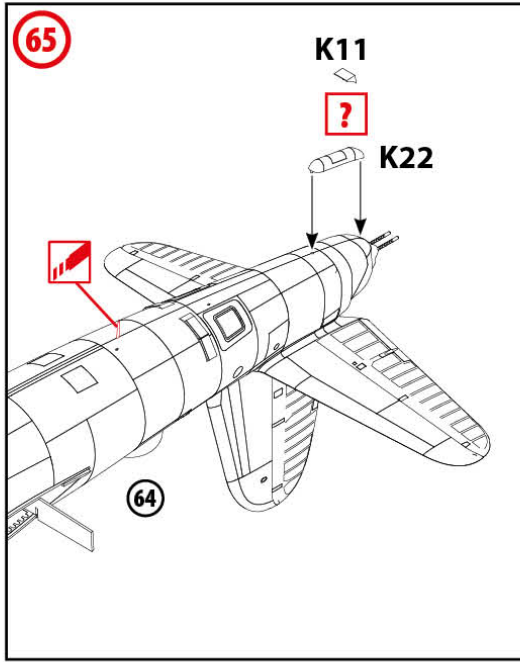

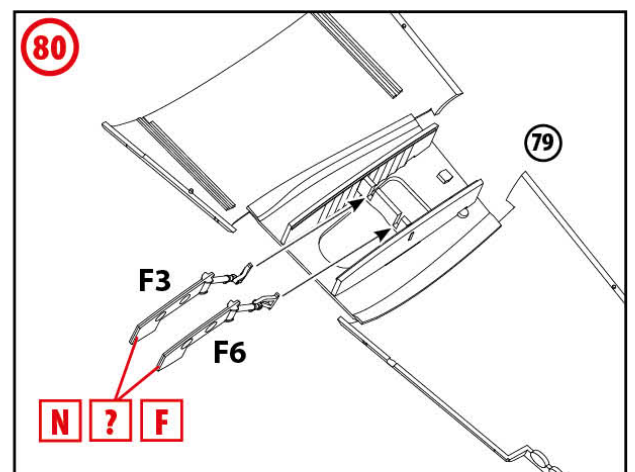
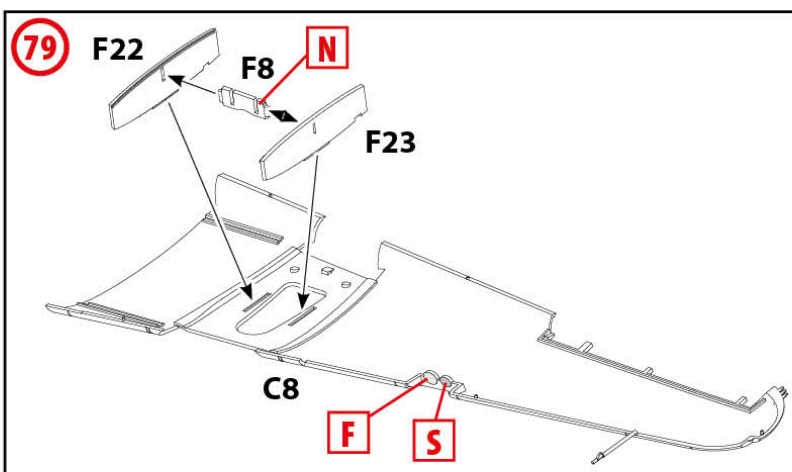
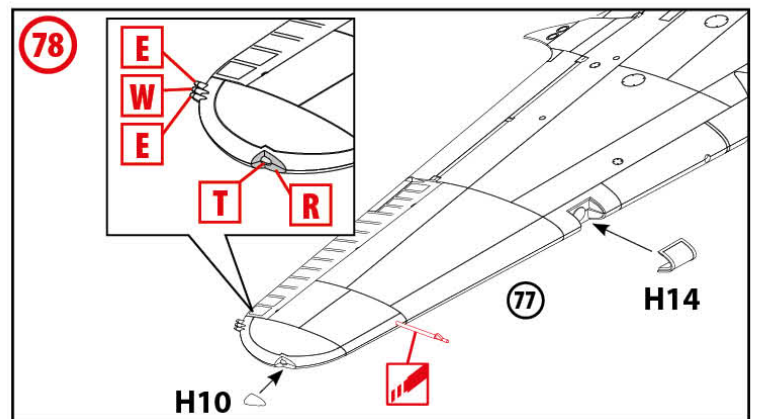
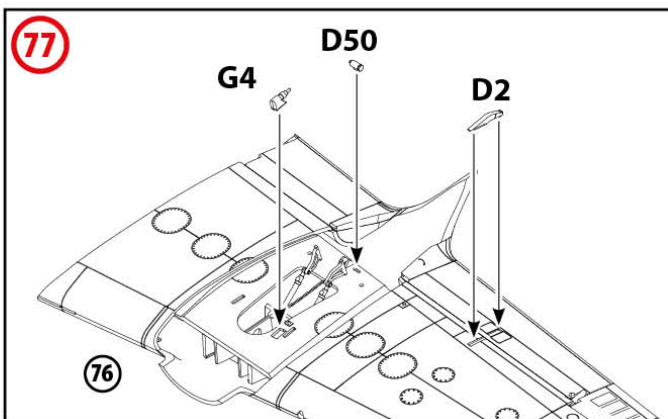
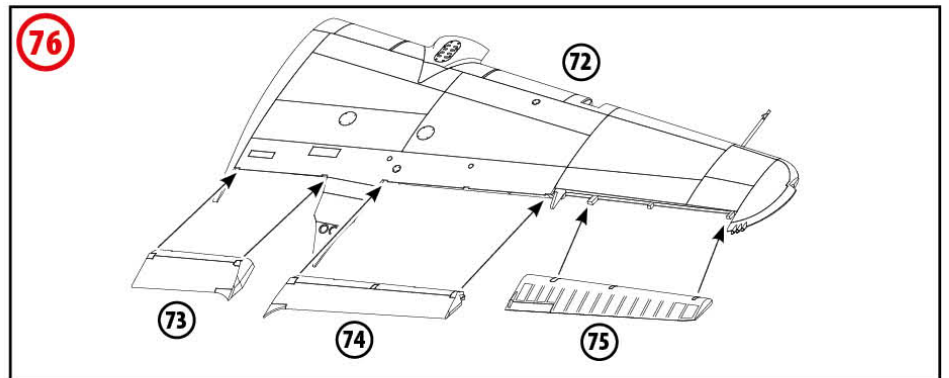
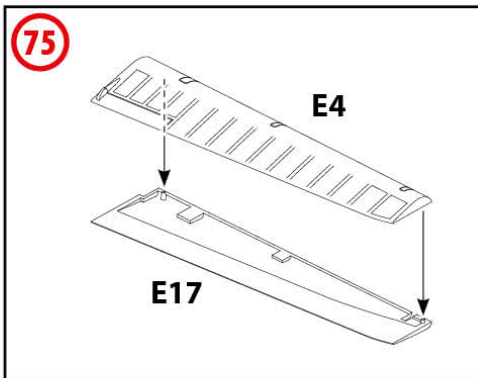
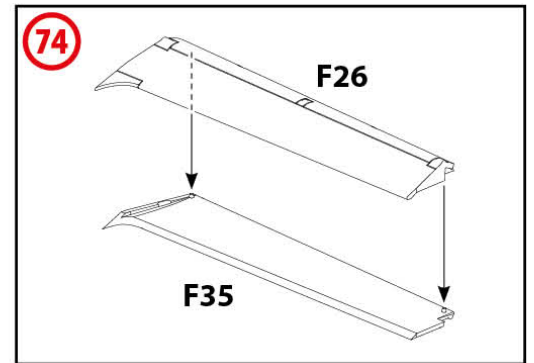
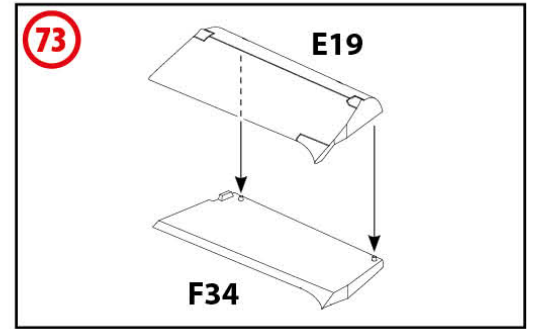
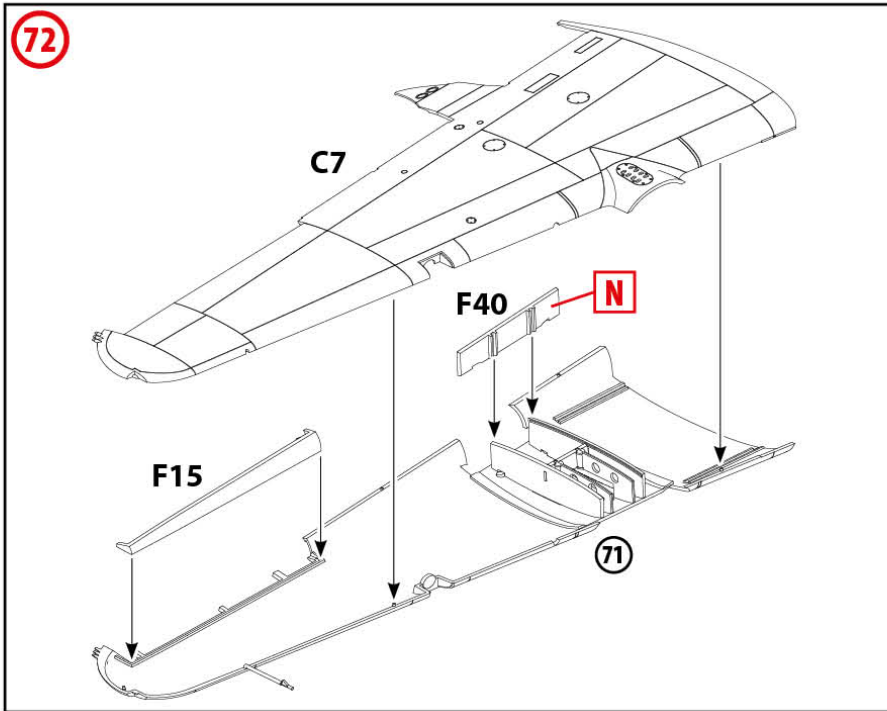



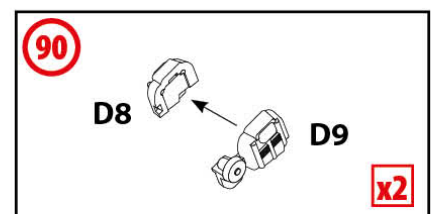
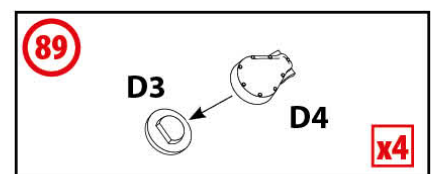
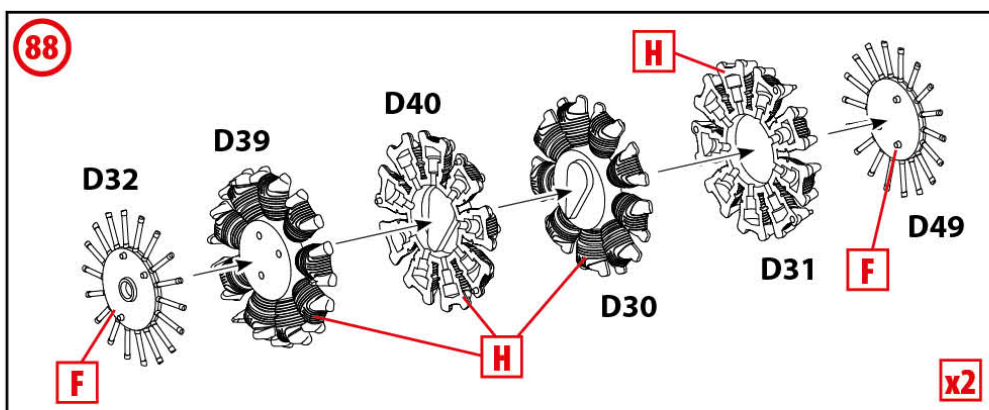
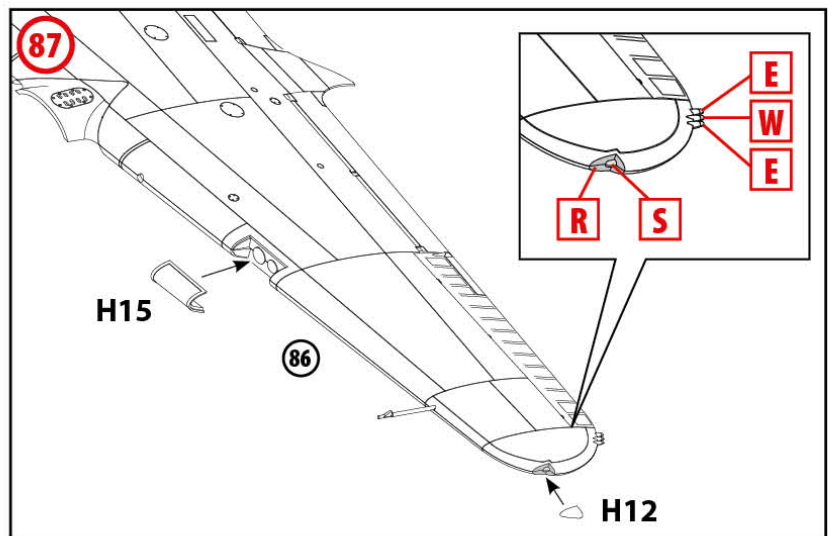
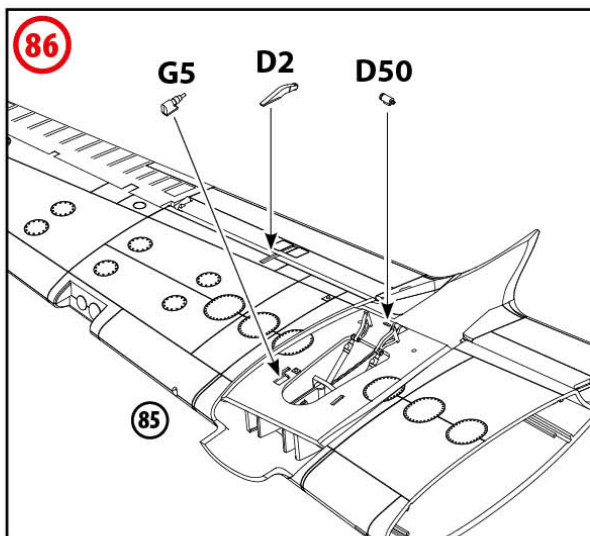
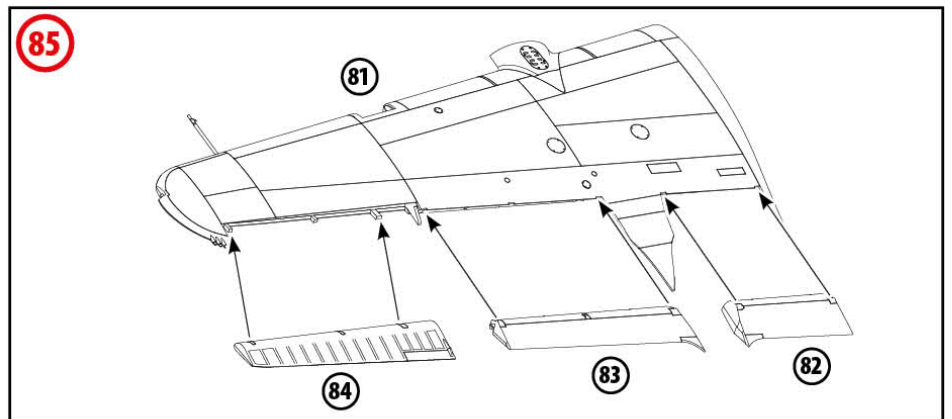
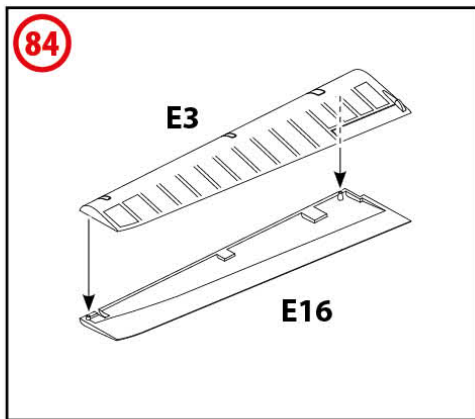
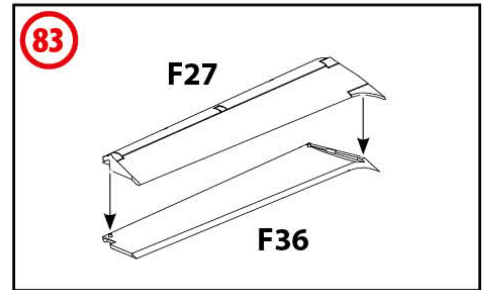
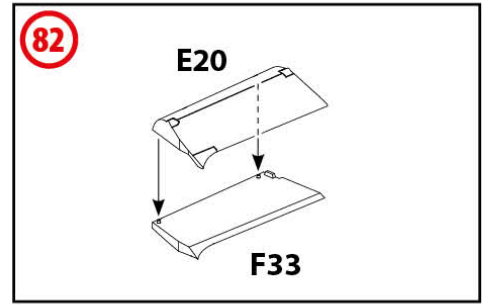
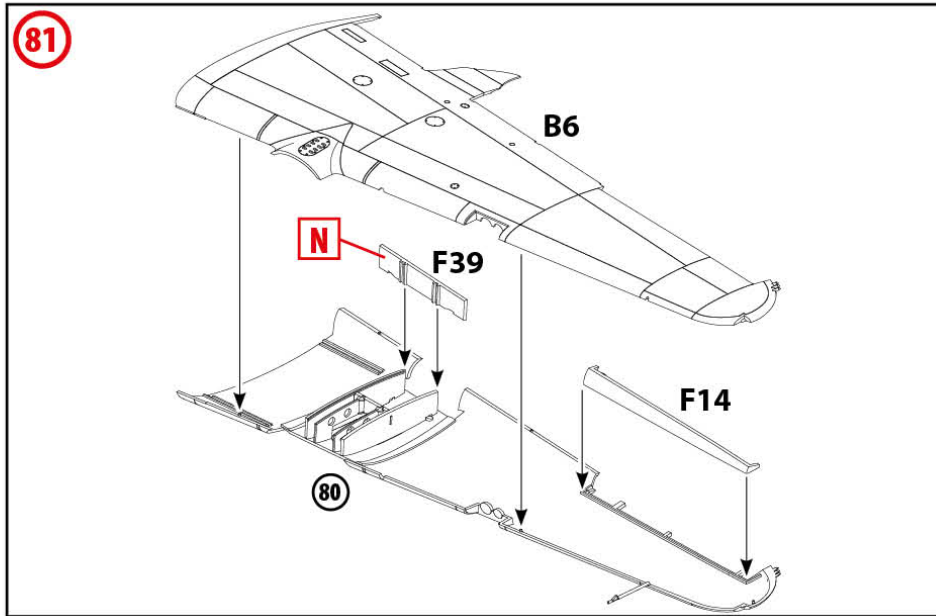

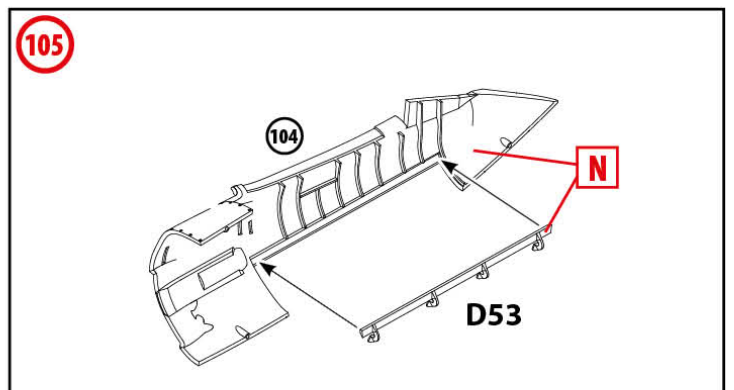
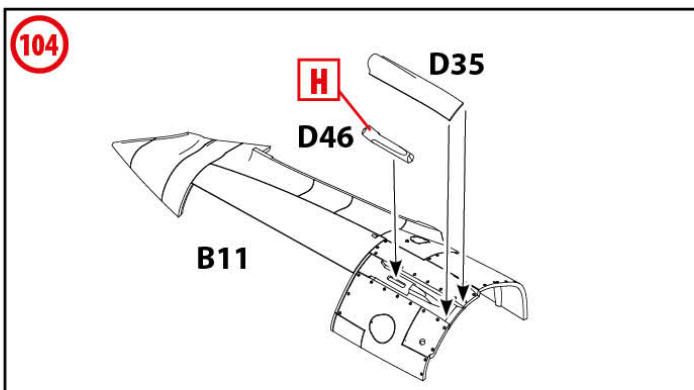
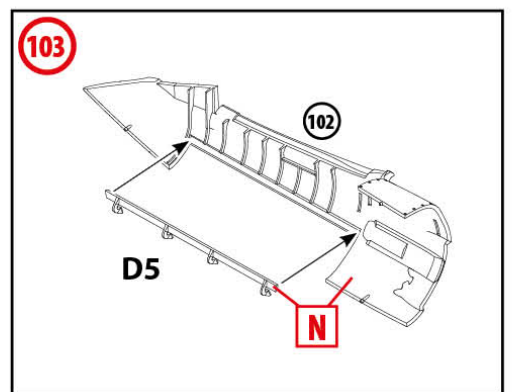
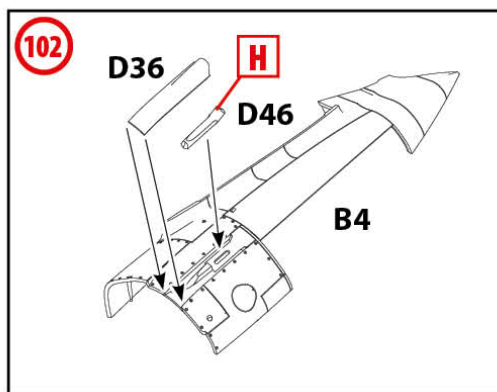
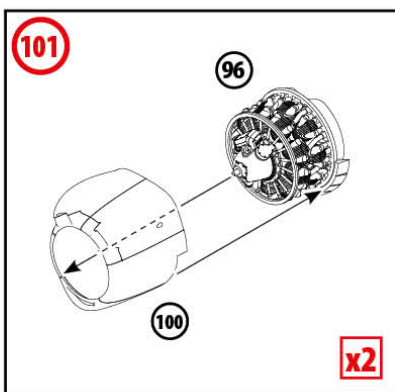
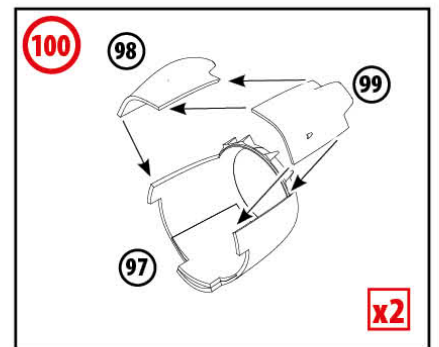
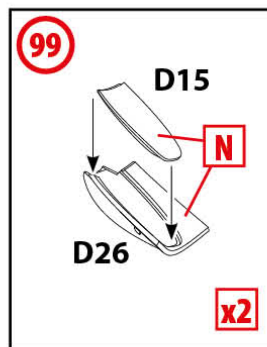
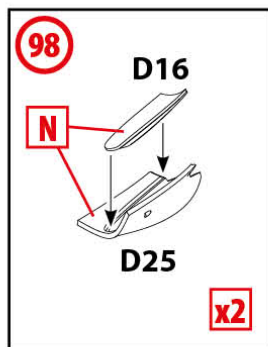
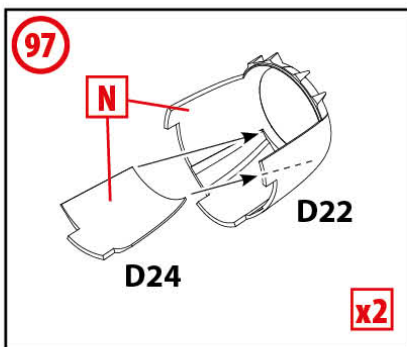
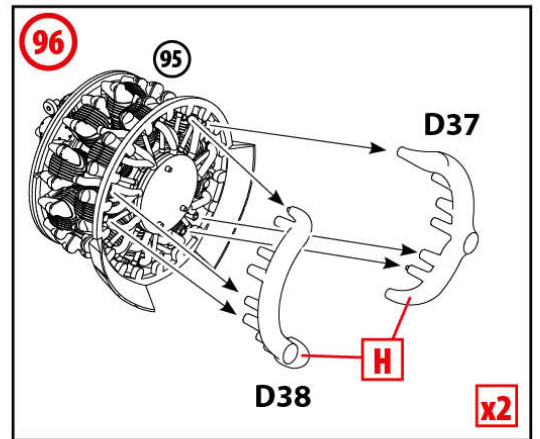
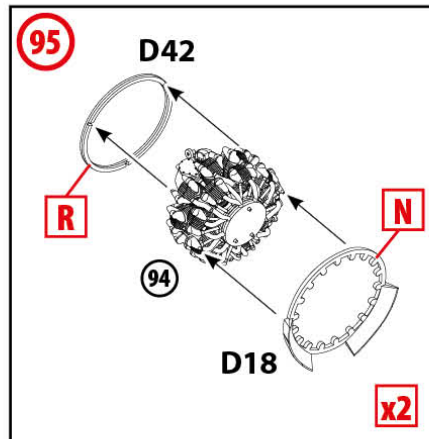
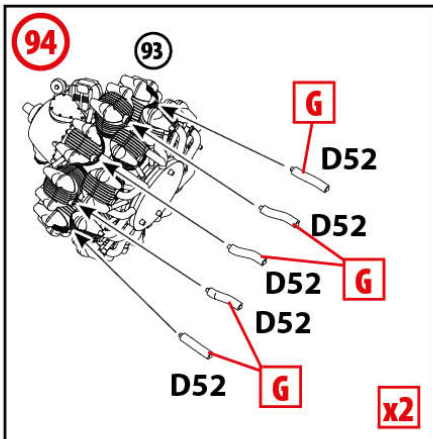
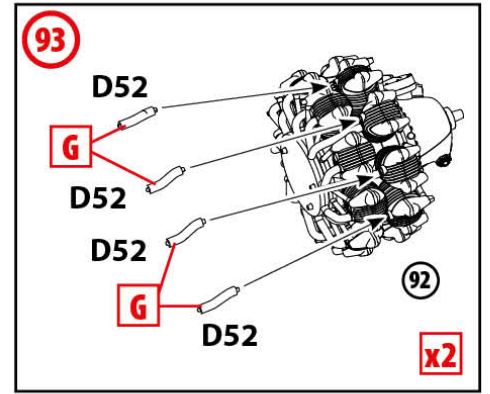
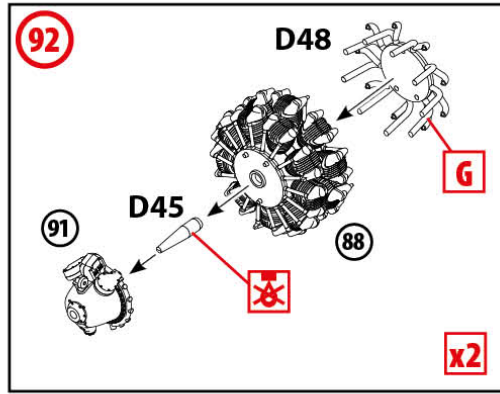
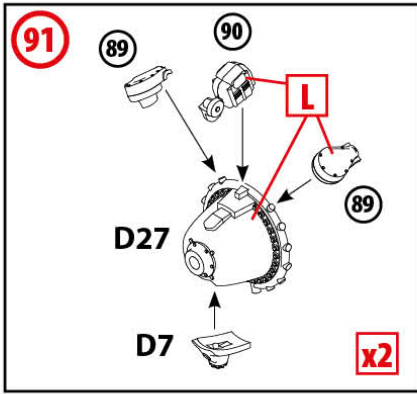

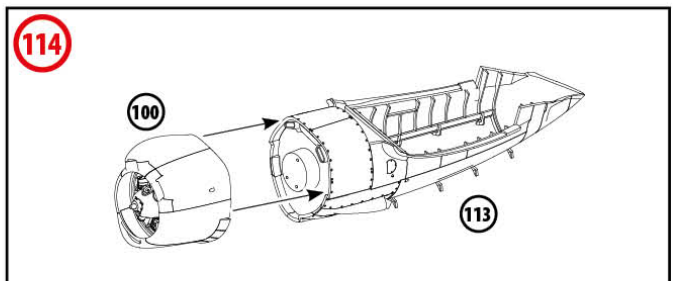
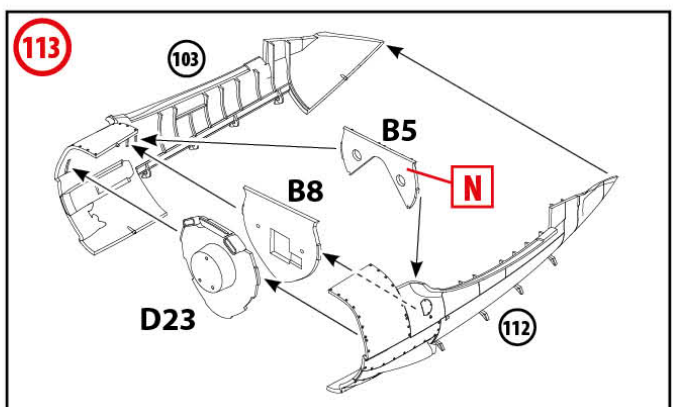
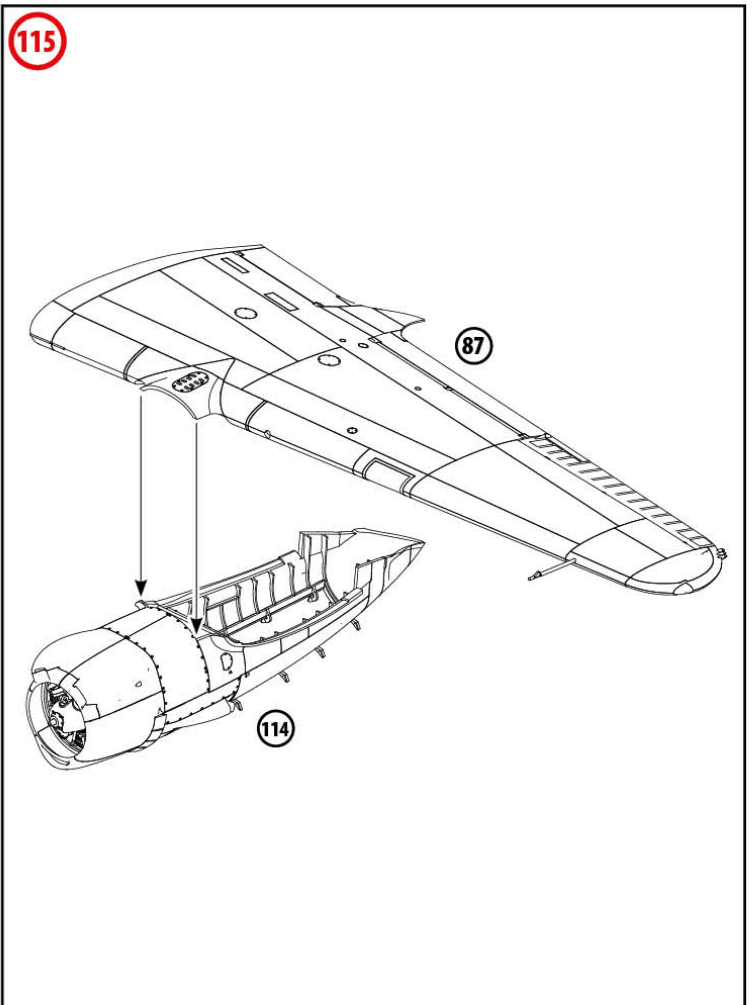
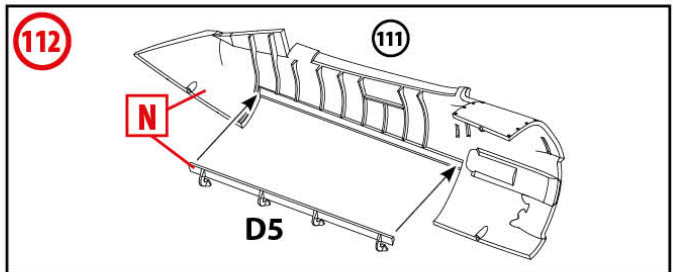
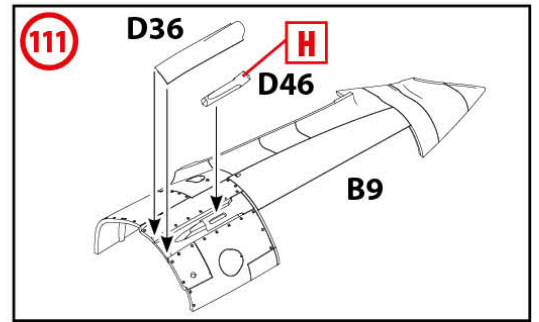
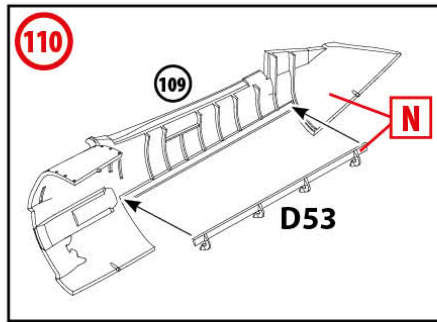
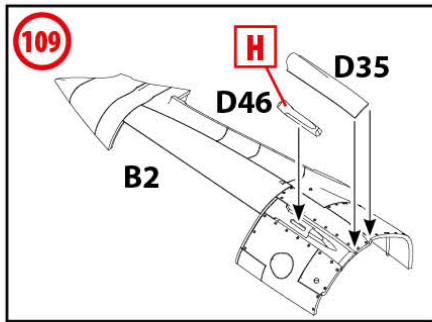
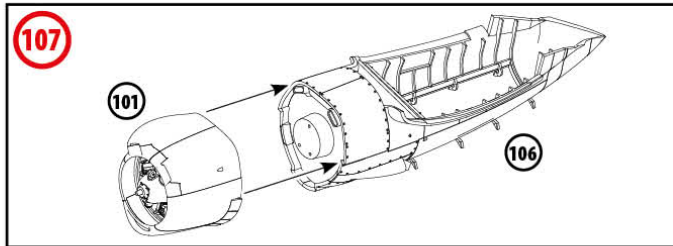
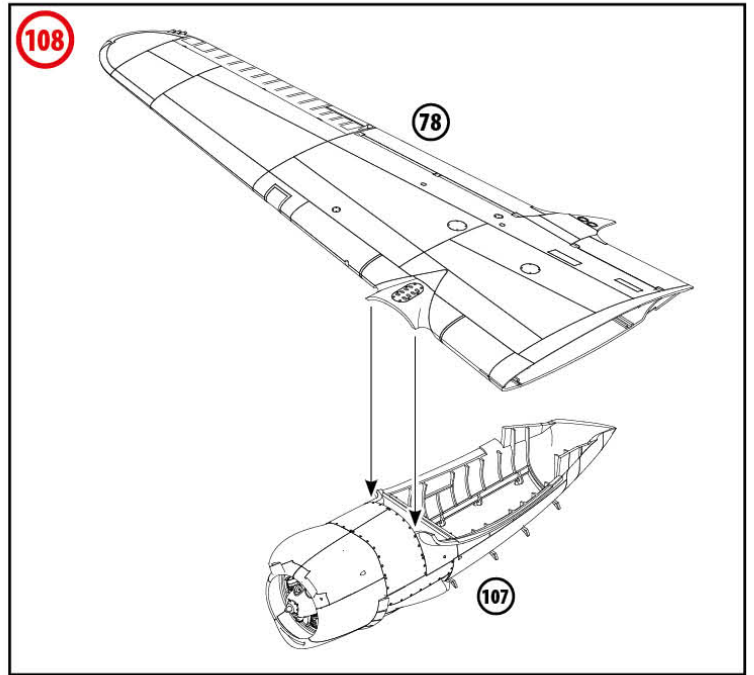
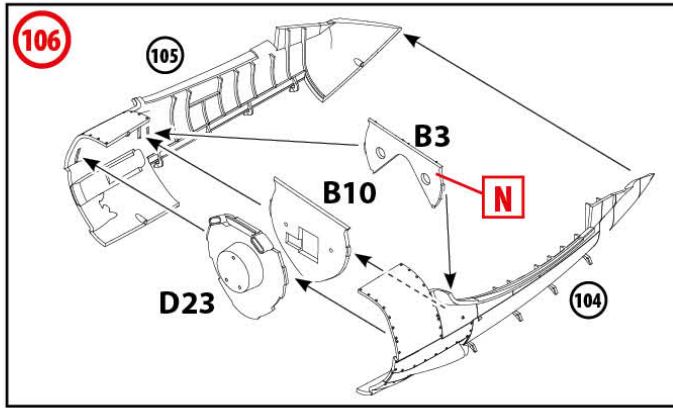

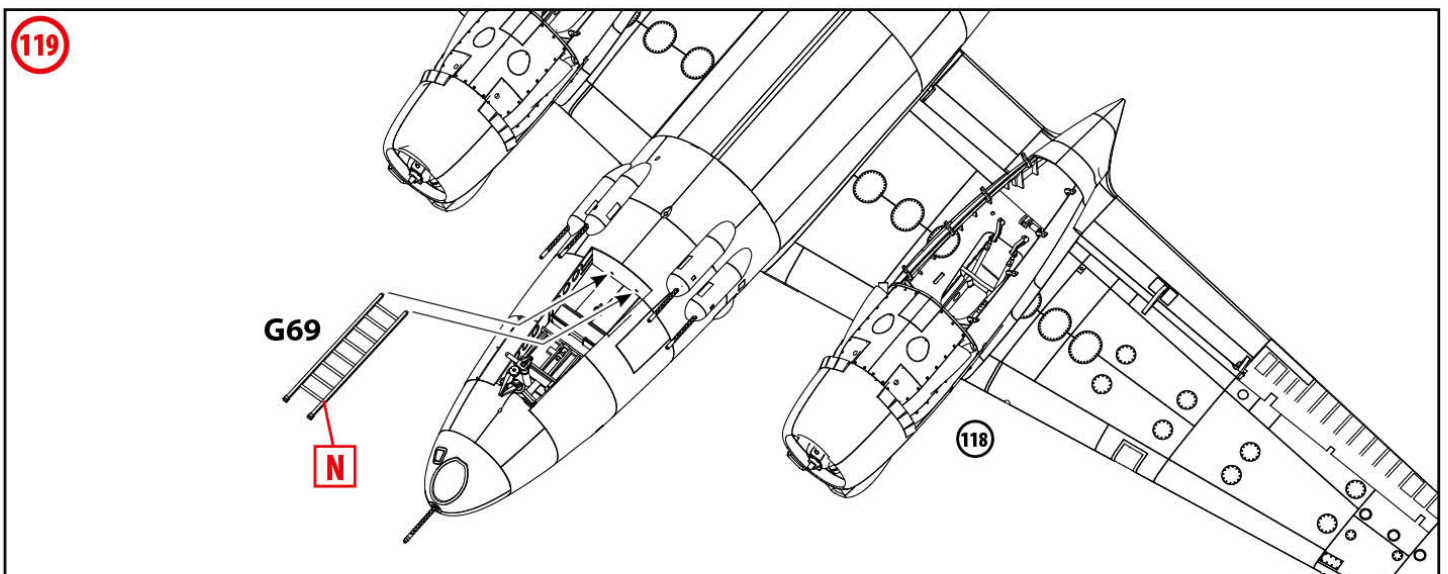
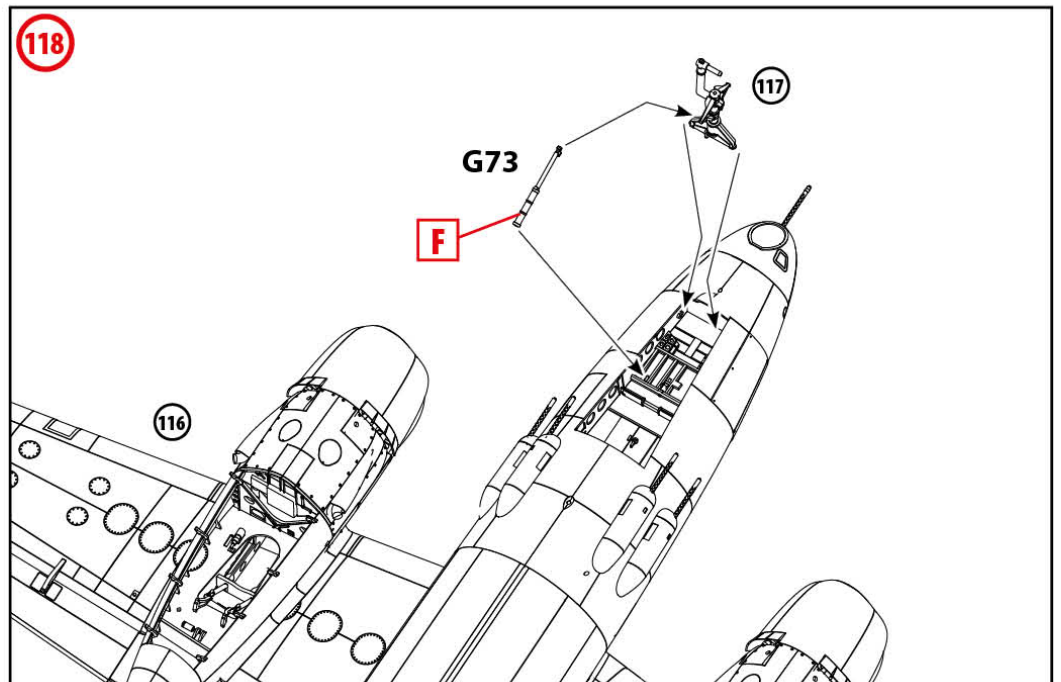
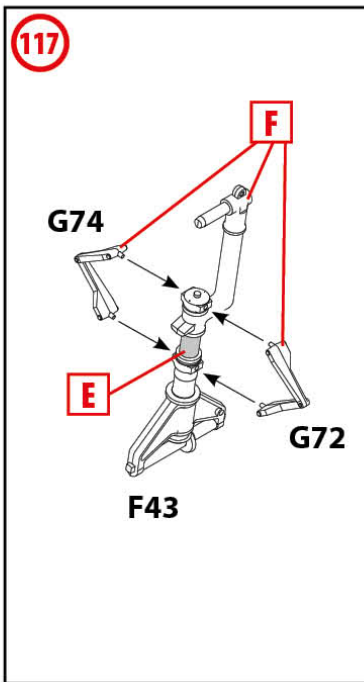
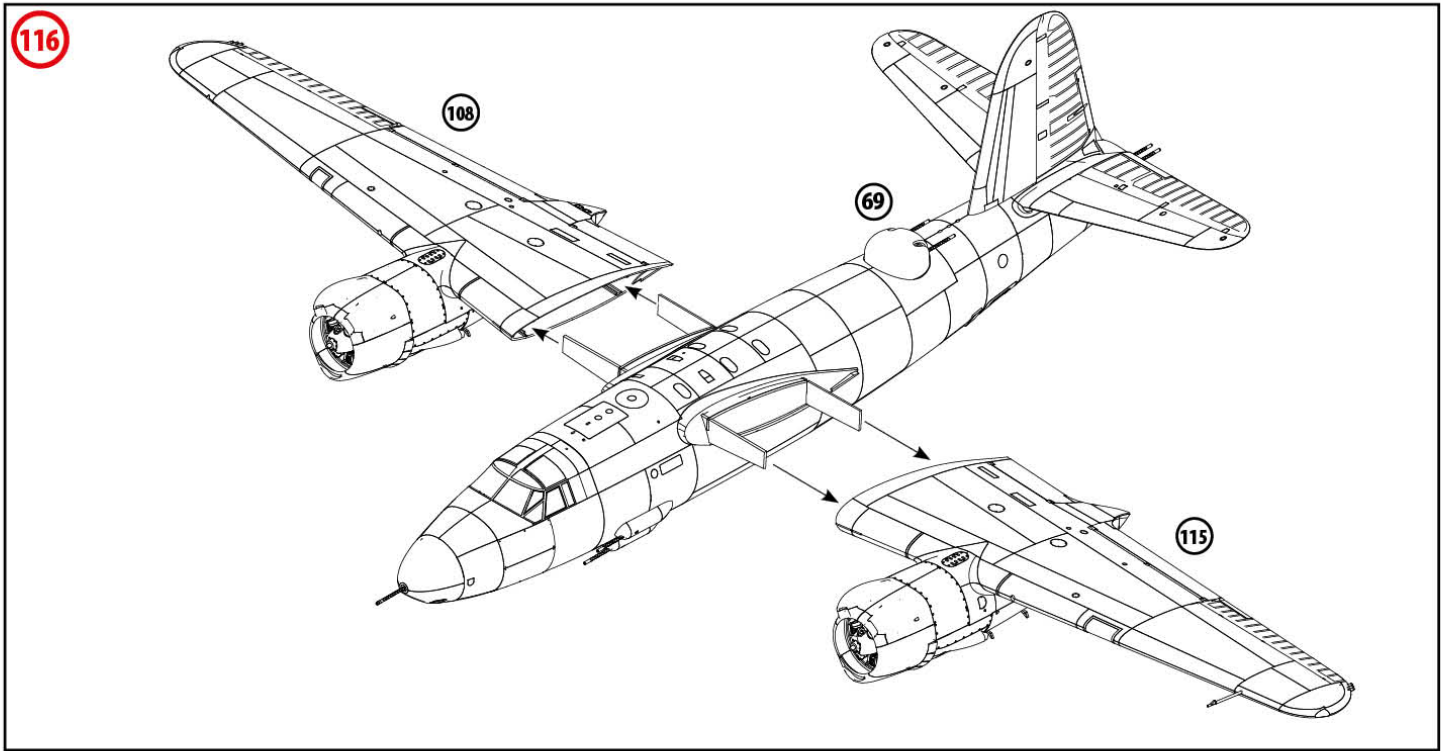

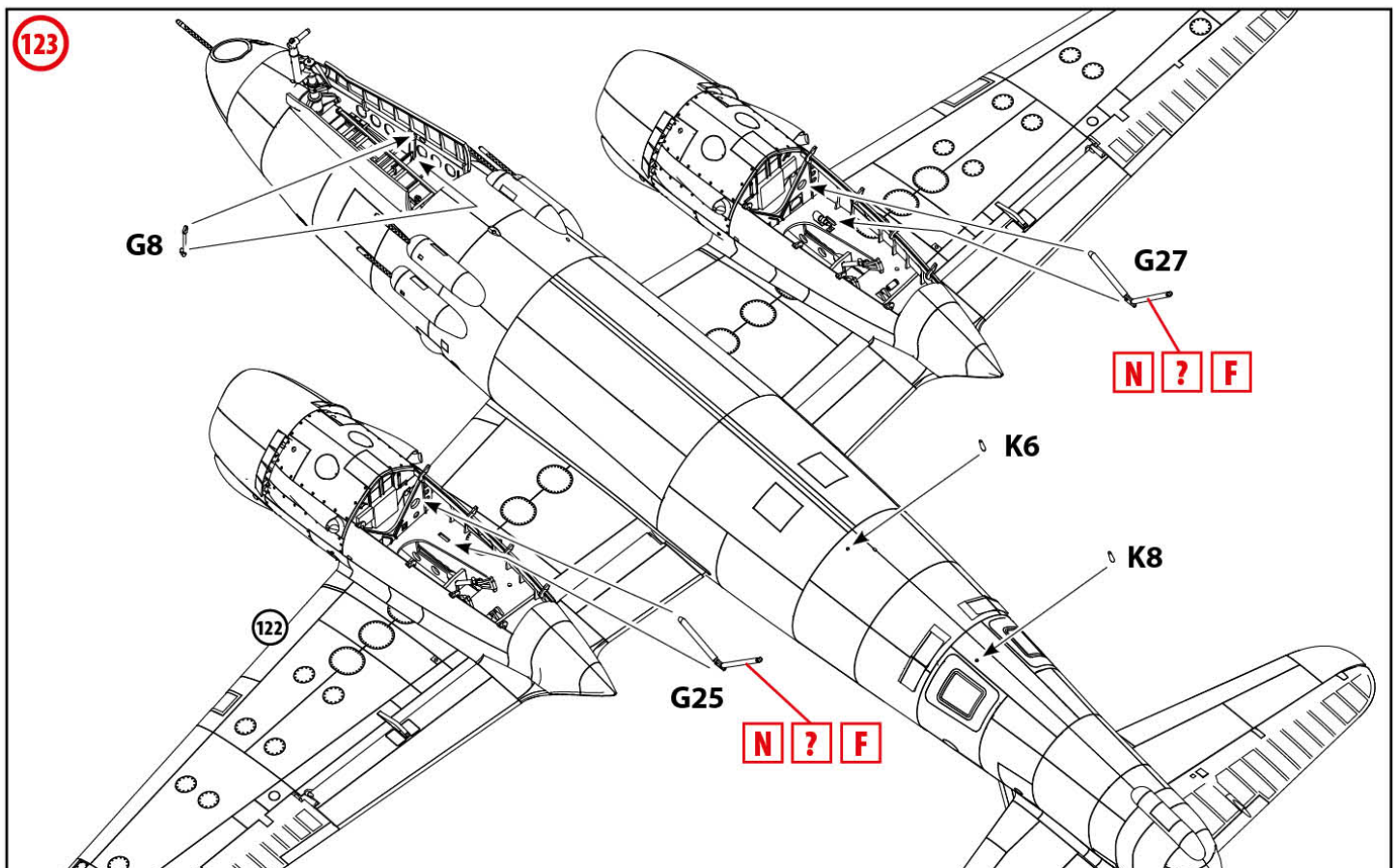
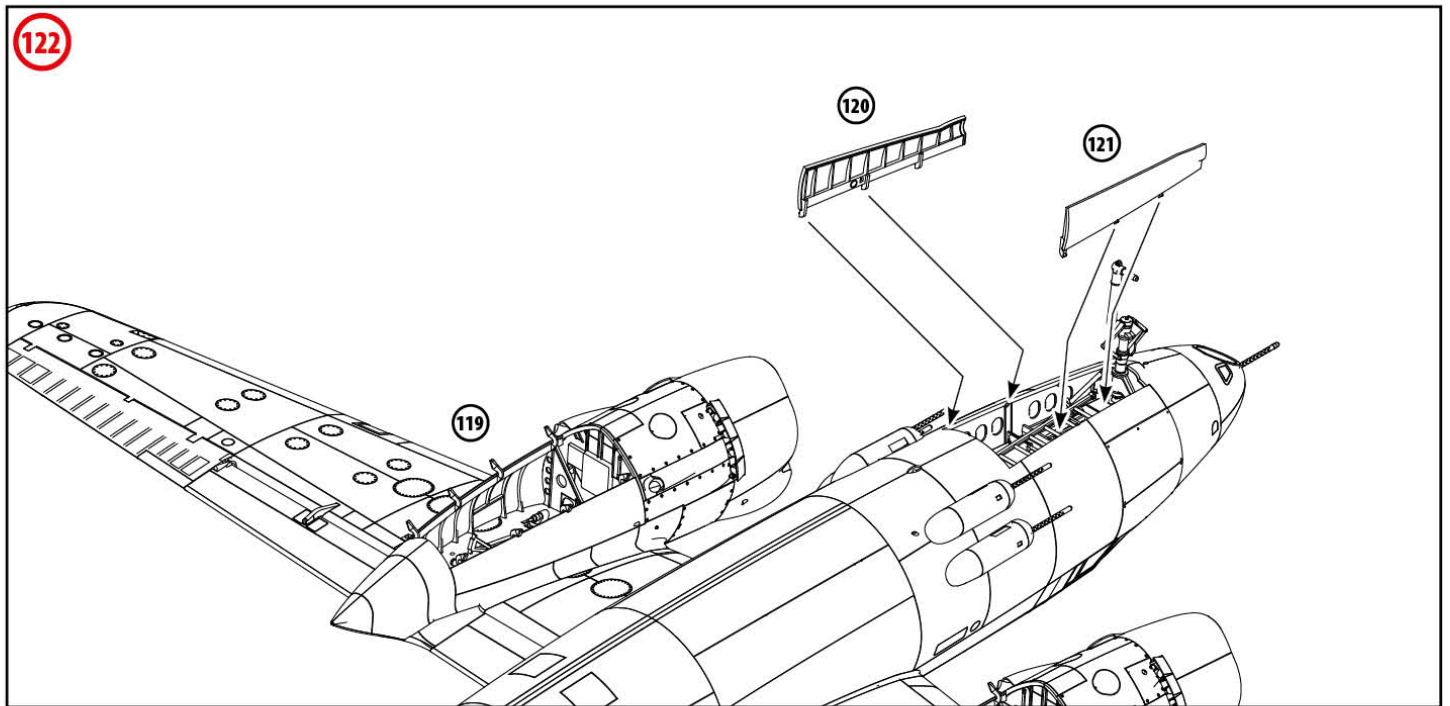
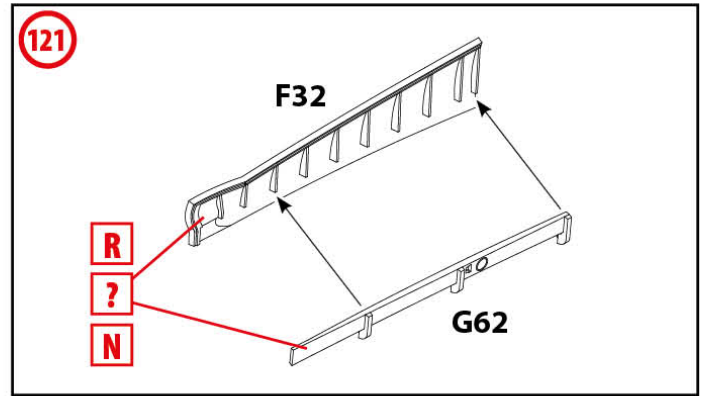
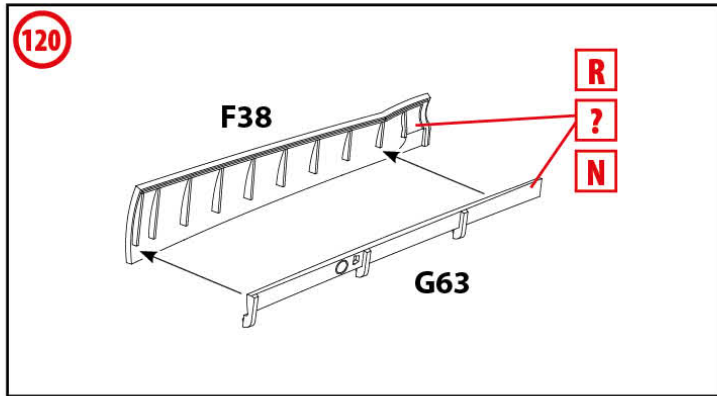

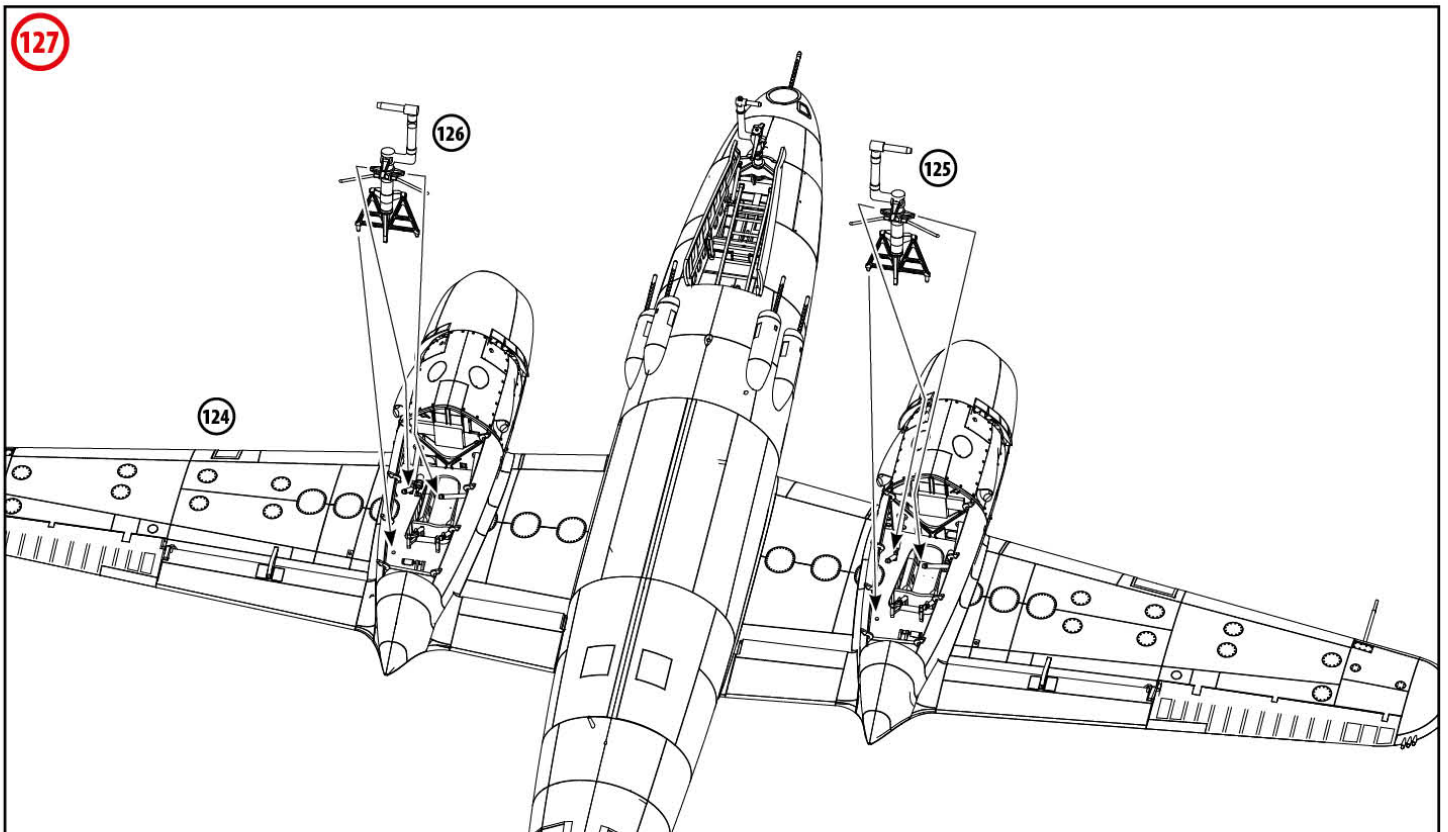
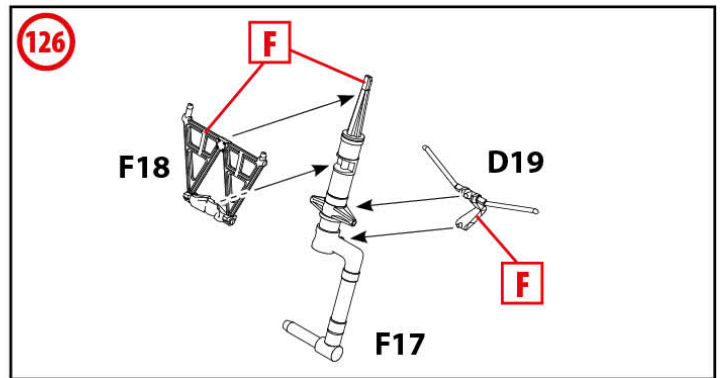
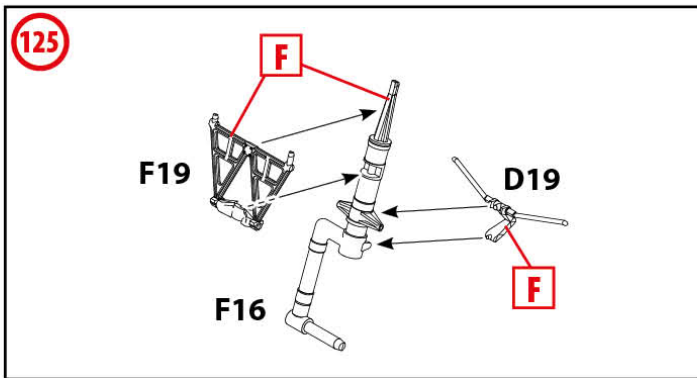
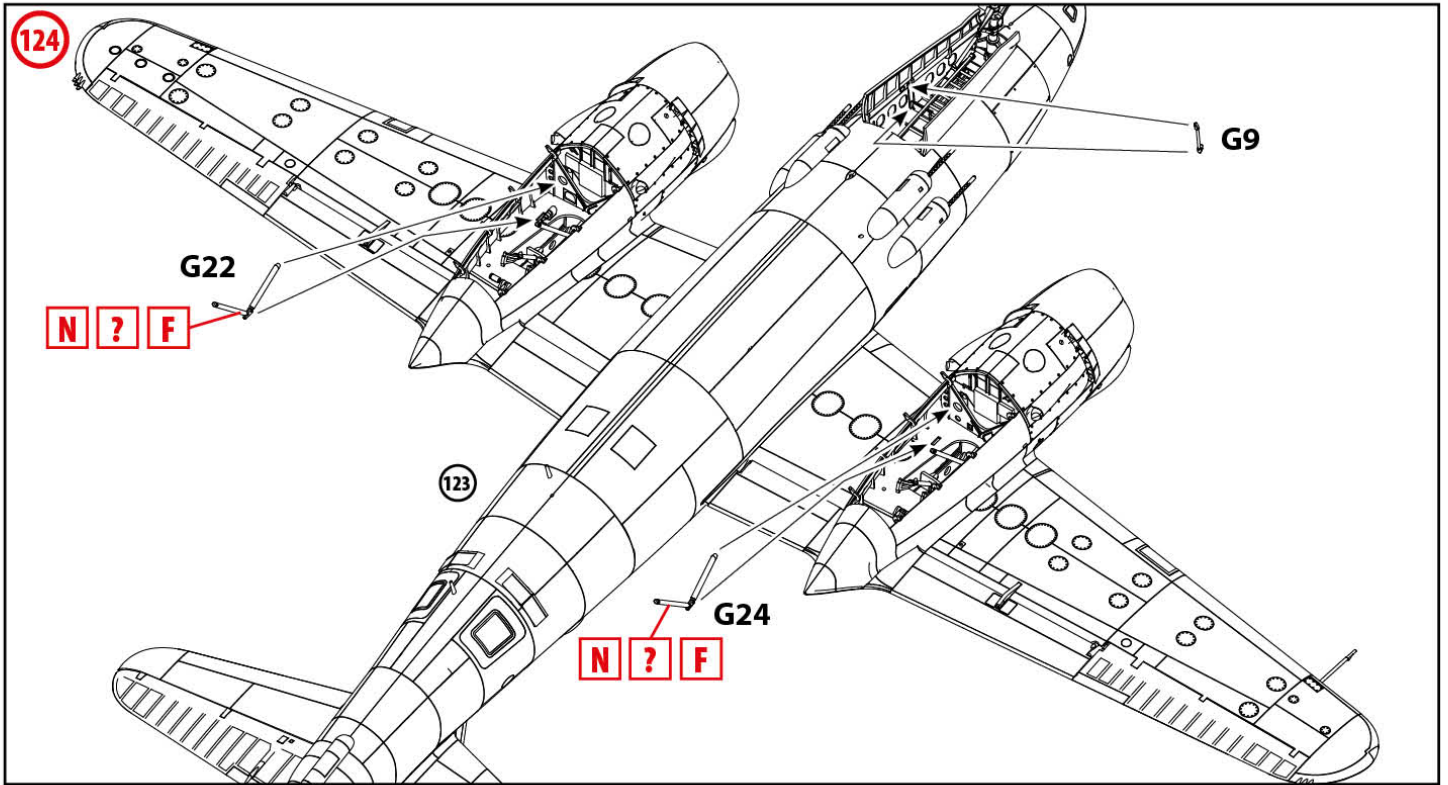

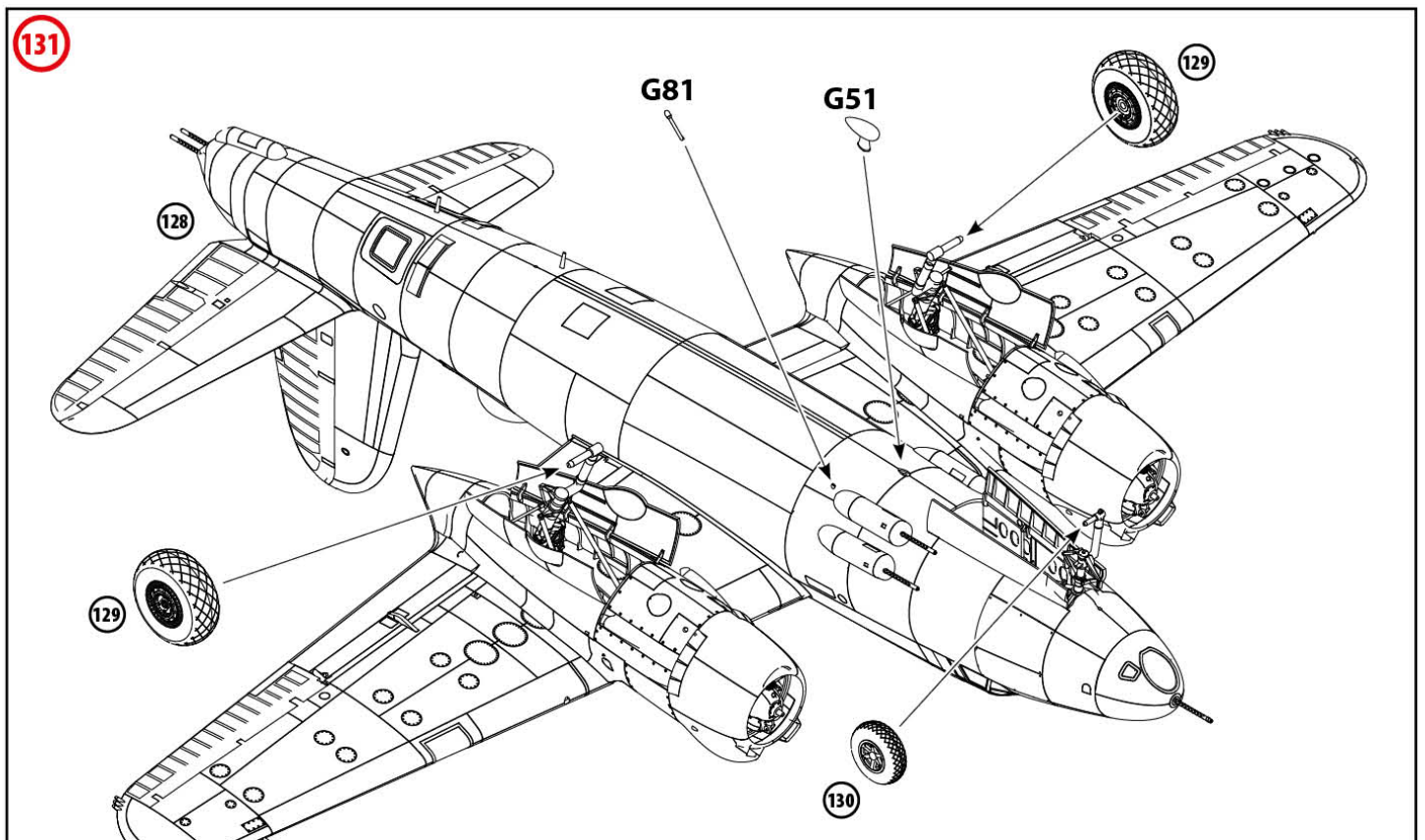
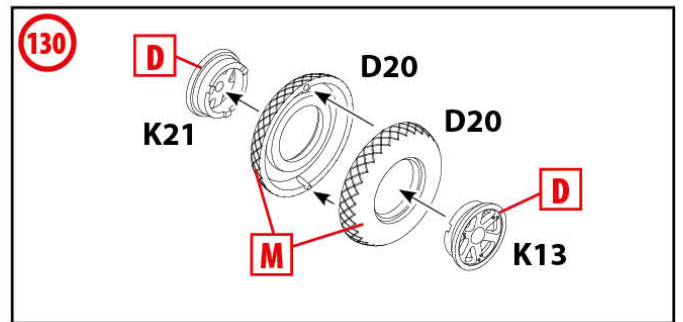
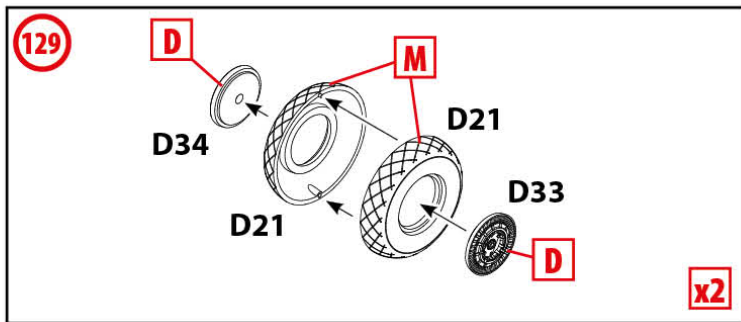
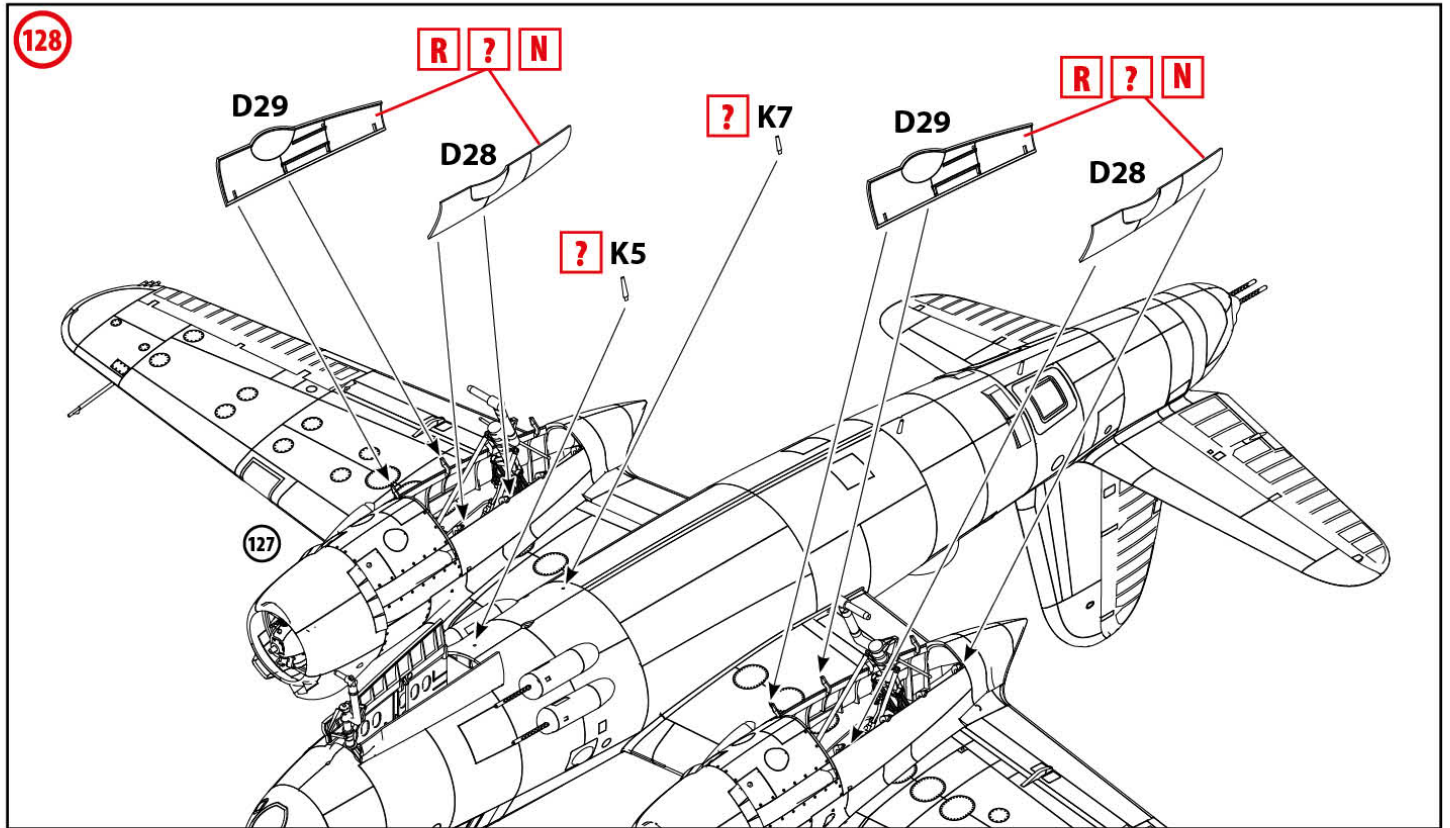

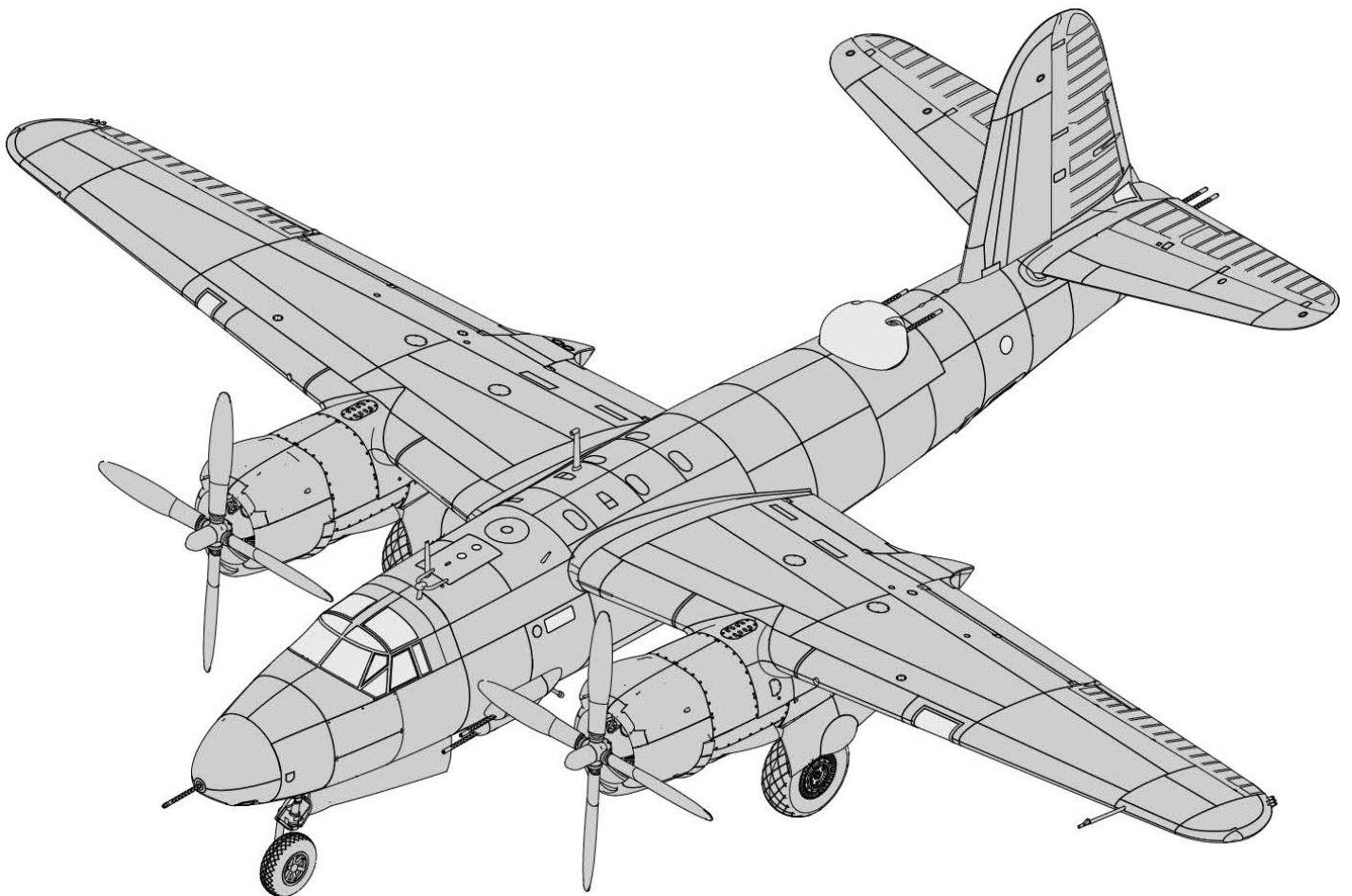
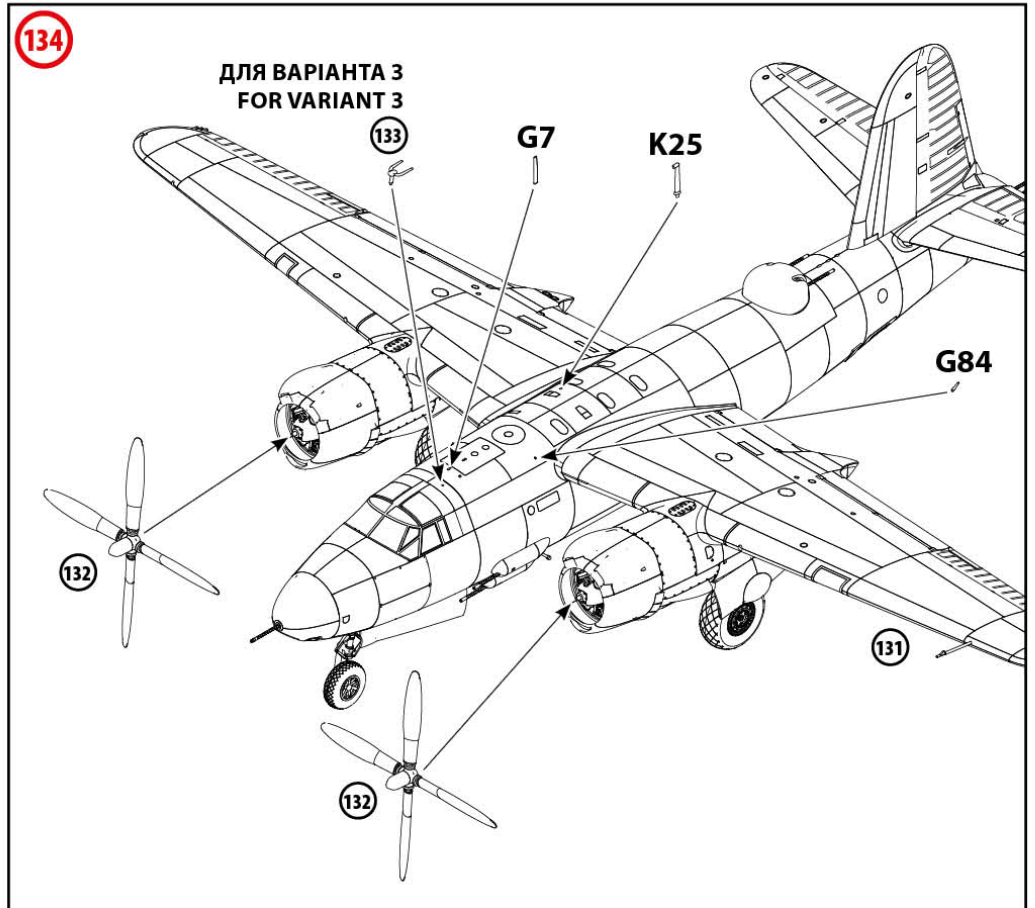
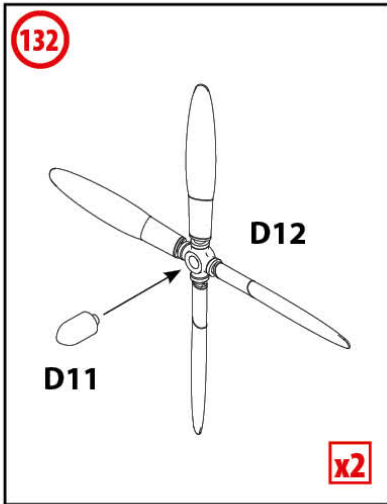



ЗОВНІШНЯ СТОРОНА ЧАСТИНИ НОСА  
OUTSIDE OF THE NOSE PART

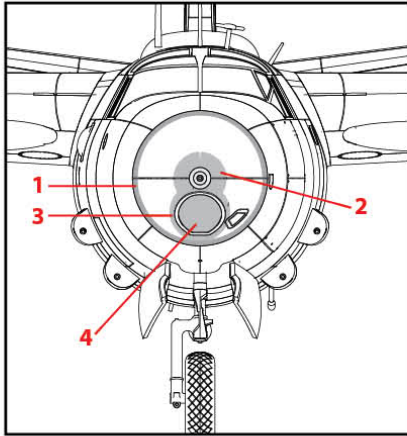

ВНУТРІШНЯ СТОРОНА ЧАСТИНИ НОСА  
INNER SIDE OF THE NOSE PART

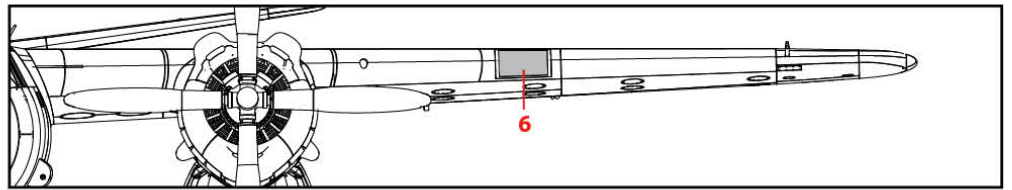
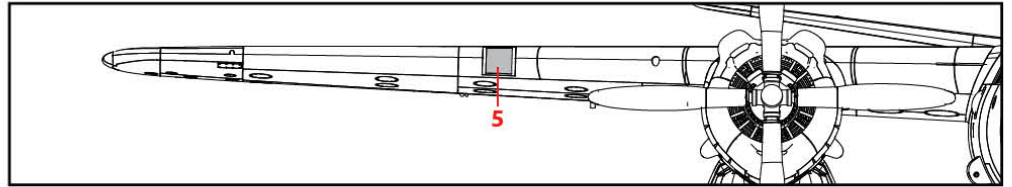
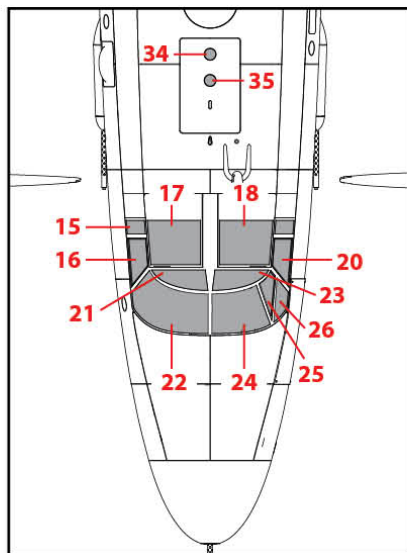
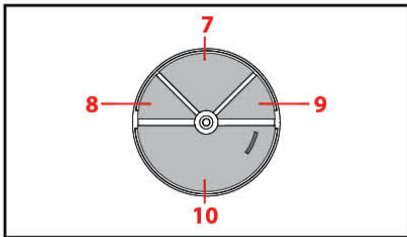

ПРАВА СТОРОНА ФЮЗЕЛЯЖУ FUSELAGE RIGHT SIDE

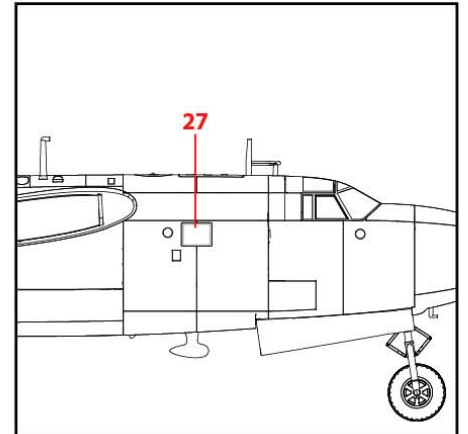
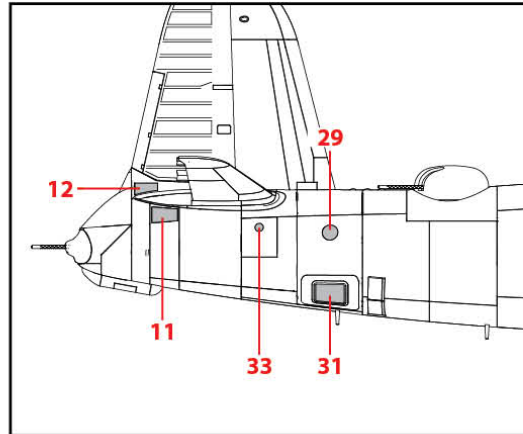

ЛІВА СТОРОНА ФЮЗЕЛЯЖУ FUSELAGE LEFT SIDE

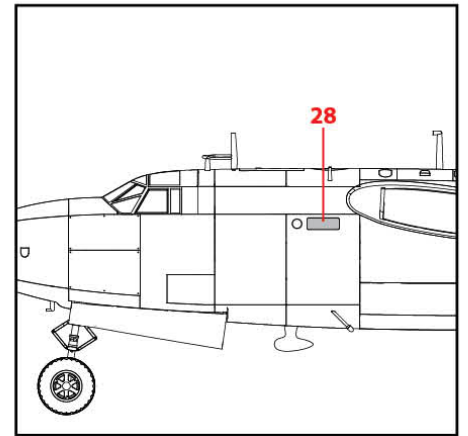
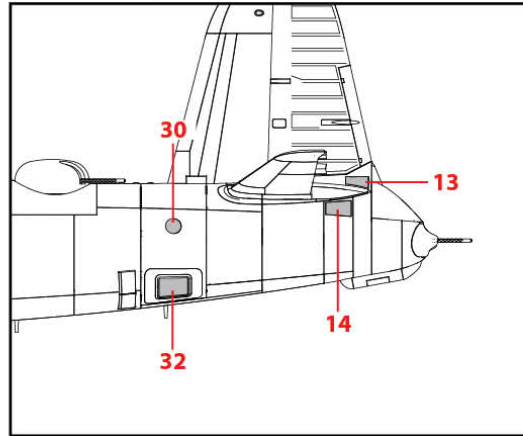

ШАБЛони масок  
MASK TEMPLATES

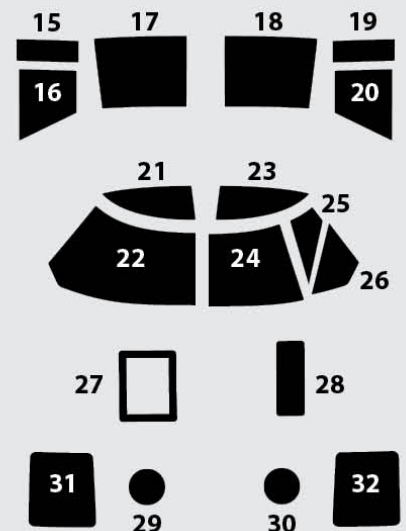
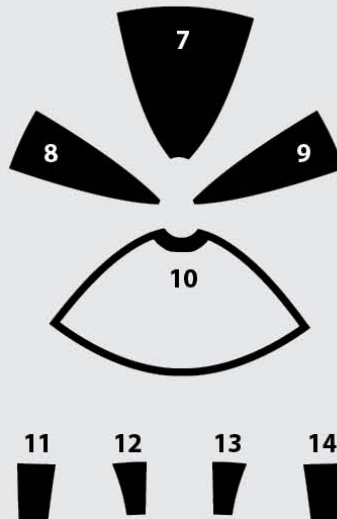
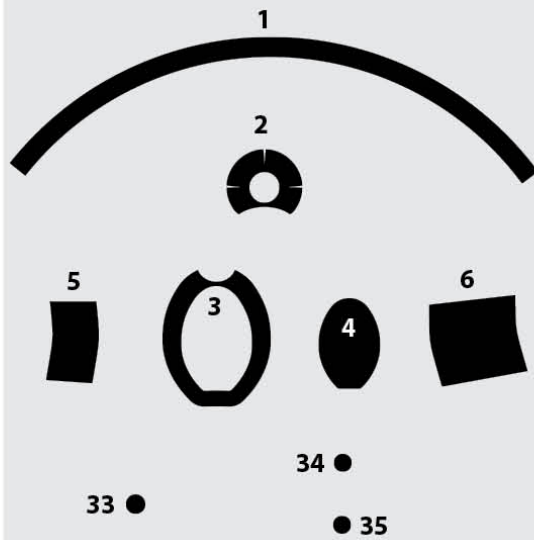

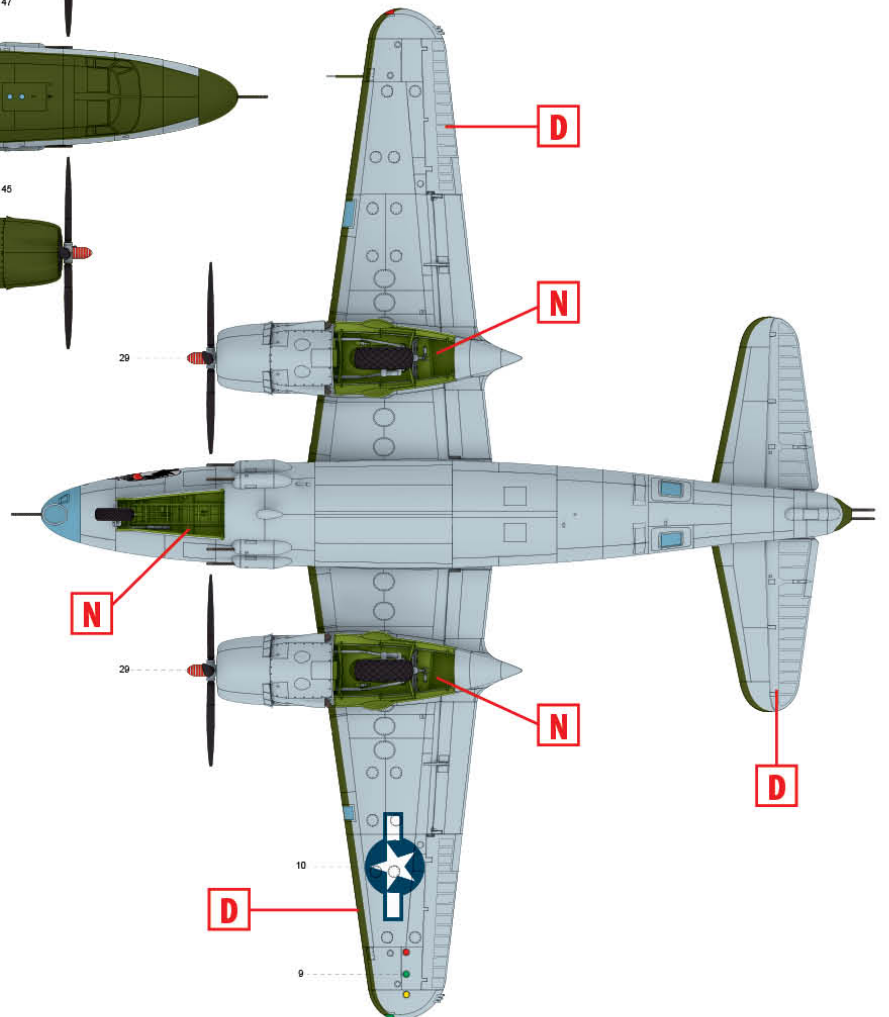
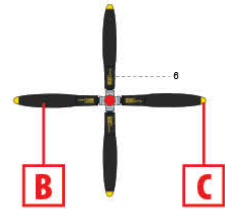
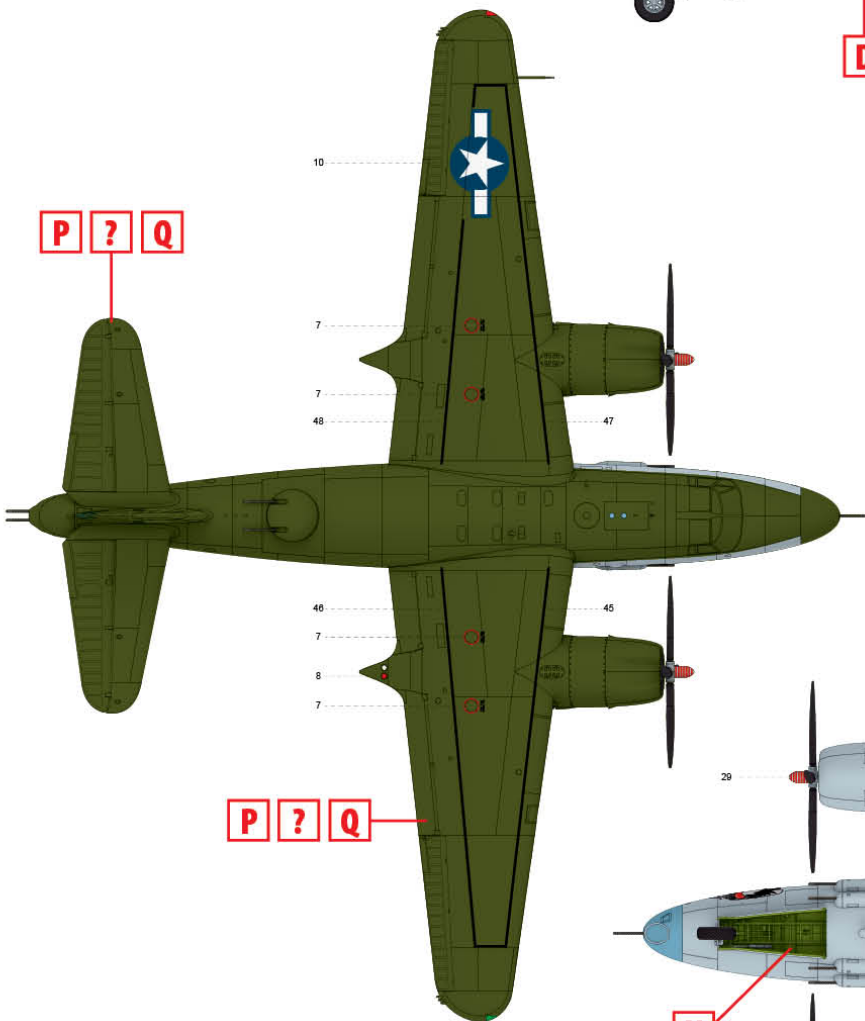
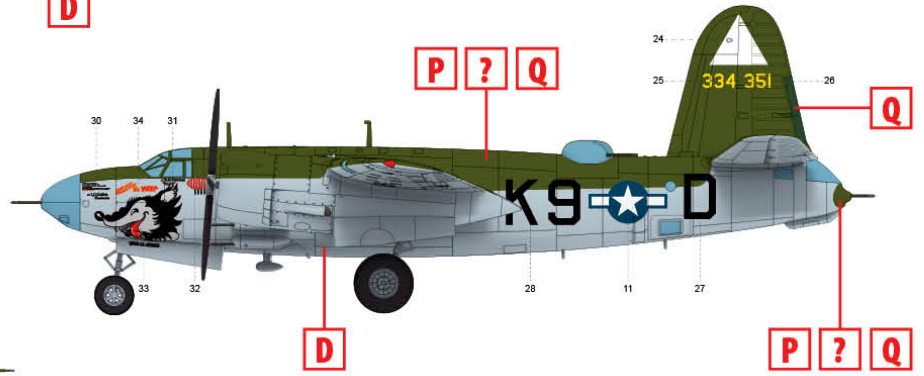
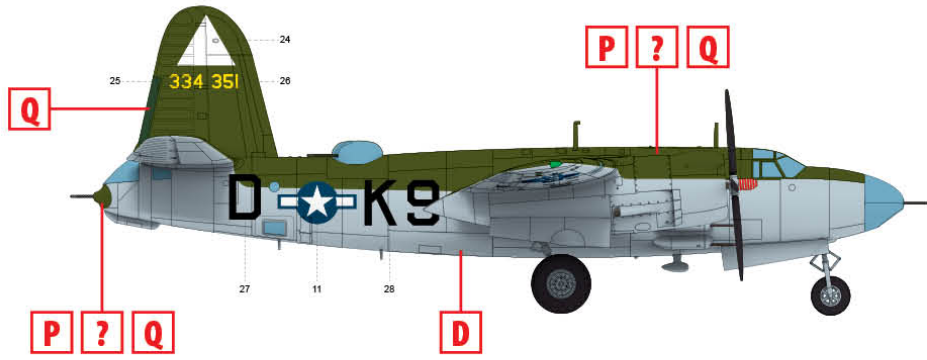

1) B-26G-5 43-34351 «Willie the Wolf»,  
494-я бомбардувальна ескадрилья,  
344-я бомбардувальна група, 1944 рік  
B-26G-5 43-34351 'Willie the Wolf',  
494th Bombardment Squadron,  
344th Bombardment Group, 1944

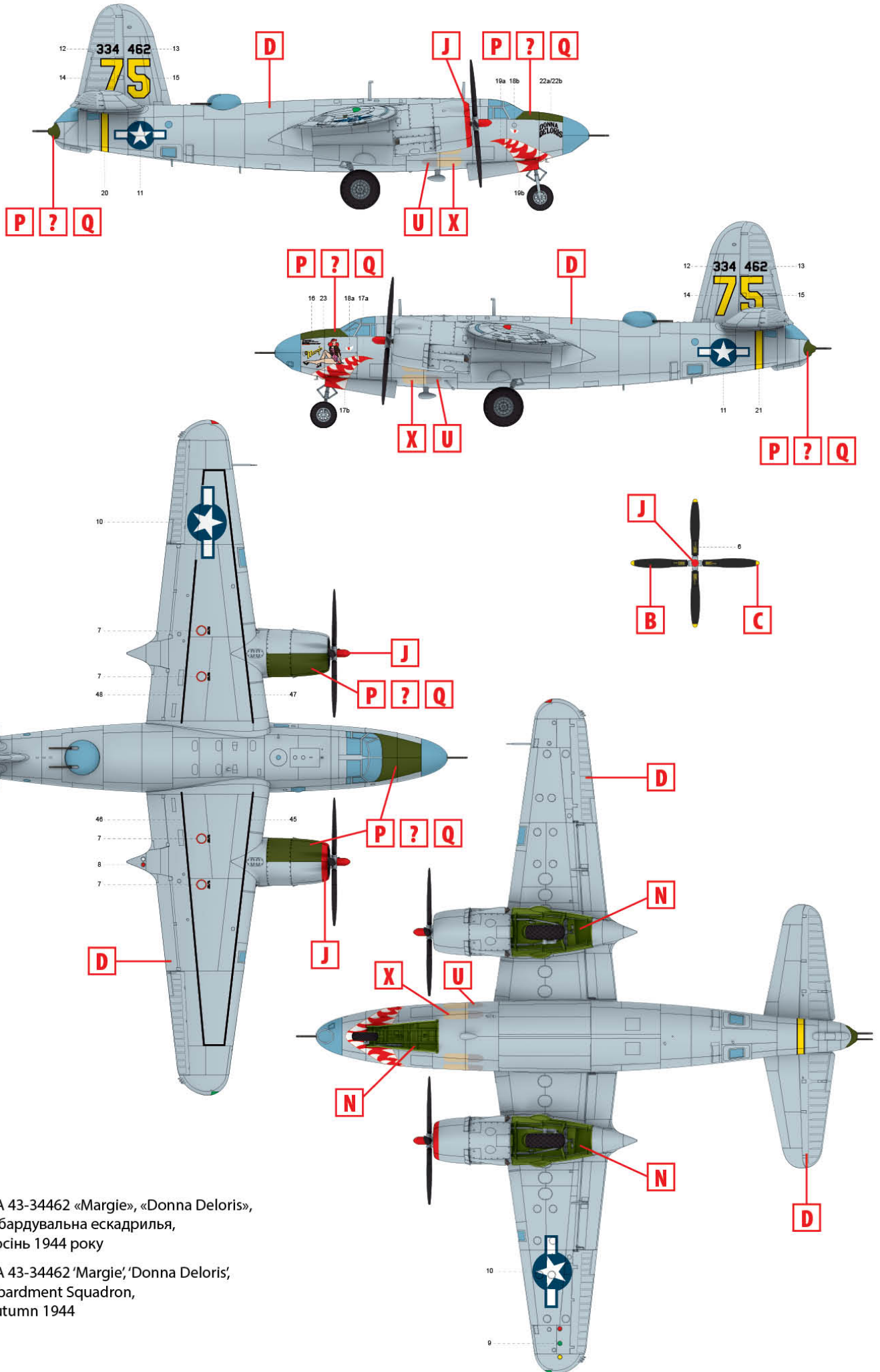

2) B-26G-5-MA 43-34462 «Margie», «Donna Deloris»,  
 444-та бомбардувальна ескадрилья,  
 Сардинія, осінь 1944 року

B-26G-5-MA 43-34462 'Margie', 'Donna Deloris',  
 444th Bombardment Squadron,  
 Sardinia, Autumn 1944

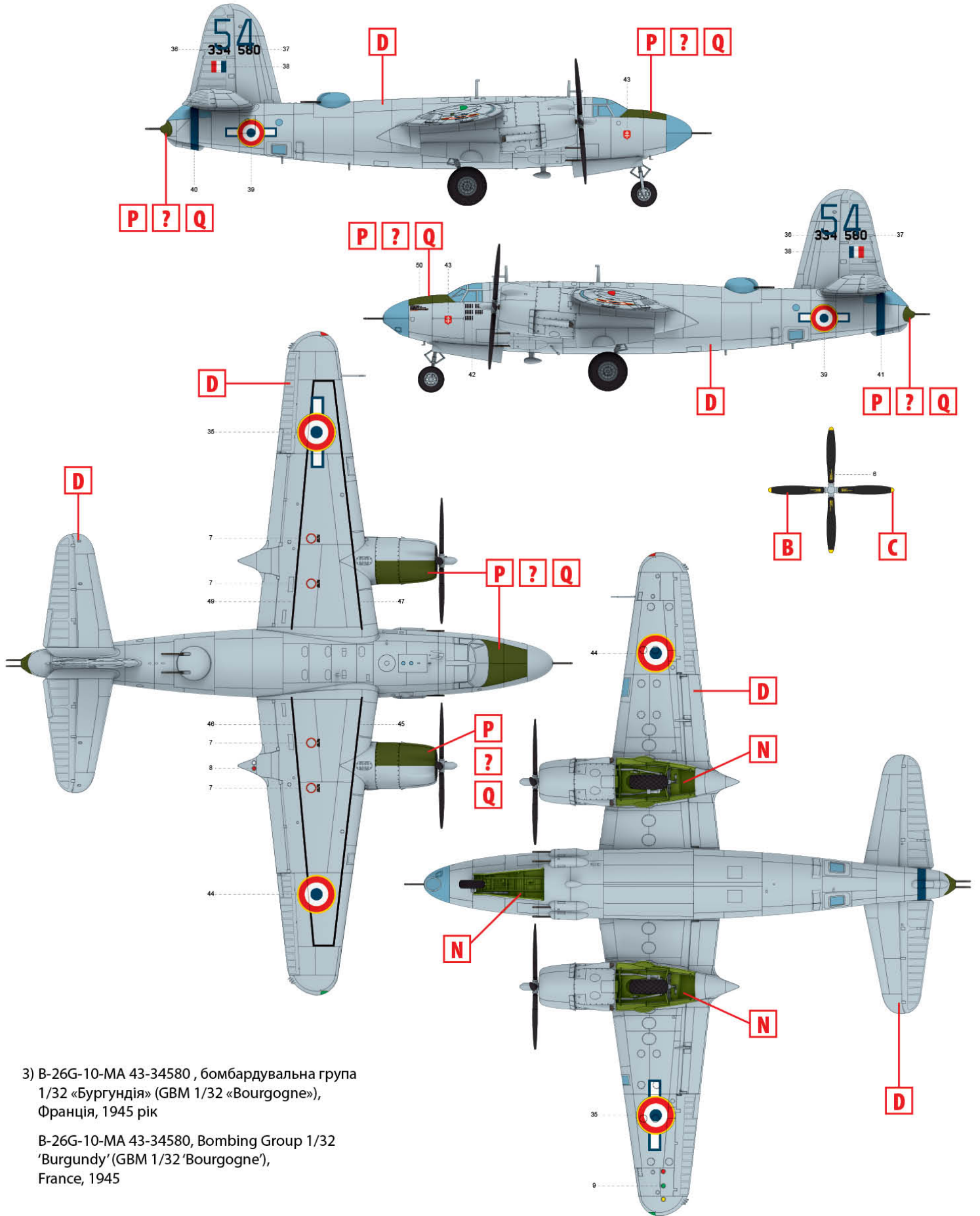

3) B-26G-10-MA 43-34580 , бомбардувальна група  
1/32 «Бургундія» (GBM 1/32 «Bourgogne»),  
Франція, 1945 рік

B-26G-10-MA 43-34580, Bombing Group 1/32  
'Burgundy' (GBM 1/32 'Bourgogne'),  
France, 1945

**ТОВ ICM Холдинг**  
вул. Бориспільська 9, корпус 64,  
02099, Київ, Україна  
Тел./факс: +38(044) 369 54 12  
E-mail: support@icm.com.ua

**ICM Holding**  
9 Boryspilska str., build. 64  
02099, Kyiv, Ukraine  
Tel./Fax: +38(044) 369 54 12  
E-mail: support@icm.com.ua