

eduard

1/48



# Barbarossa

Limited Edition  
Dual Combo

11127 - NAV1



Carefully read instruction sheet before assembling. When you use glue or paint, do not use near open flame and use in well ventilated room. Keep out of reach of small children. Children must not be allowed to suck any part, or pull vinyl bag over the head.



Před započítím stavby si pečlivě prostudujte stavební návod. Při používání barev a lepidel pracujte v dobře větrané místnosti. Lepidla ani barvy nepoužívejte v blízkosti otevřeného ohně. Model není určen malým dětem, mohlo by dojít k požití drobných dílů.

## INSTRUCTION SIGNS \* INSTR. SYMBOLS \* INSTRUKTION SINNBILDEN \* SYMBOLES \* 記号の説明

OPTIONAL  
VOLBABEND  
OHNOUTSAND  
BROUSITOPEN HOLE  
VYVRTAT OTVORSYMETRICAL ASSEMBLY  
SYMETRICKÁ MONTÁŽREMOVE  
ODŘÍZNOUTREVERSE SIDE  
OTOČITAPPLY EDUARD MASK  
AND PAINT  
POUŽIT EDUARD MASK  
NABARVIT

## PARTS



## DÍLY



## TEILE



## PIÈCES



## 部品

## PLASTIC PARTS

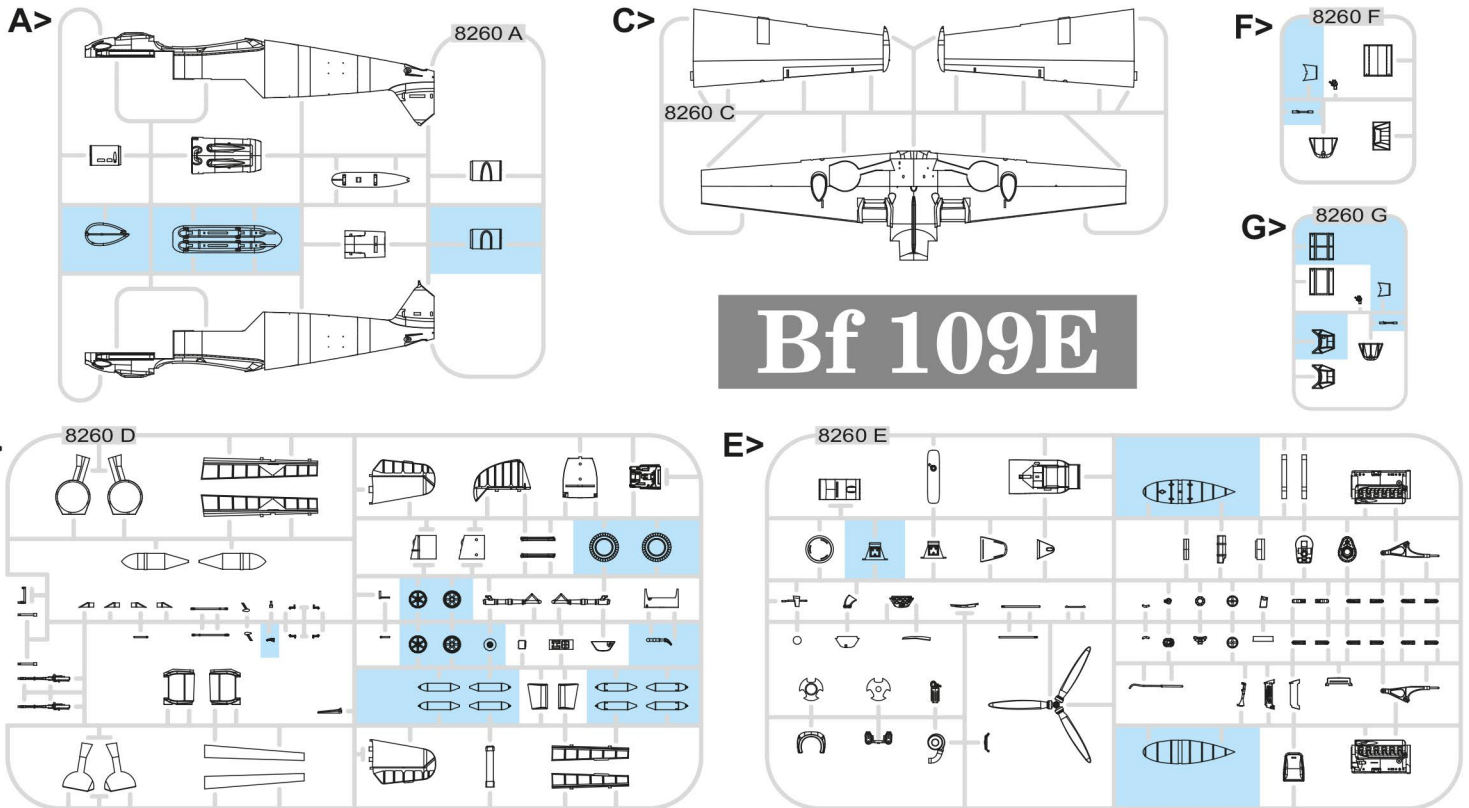

## Bf 109E

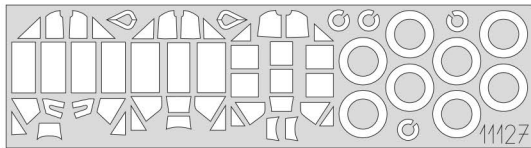
eduard  
MASK

## RP - RESIN PARTS



R1



R2



R3 2 pcs.



R4



## PE - PHOTO ETCHED DETAIL PARTS

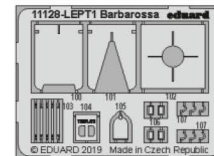
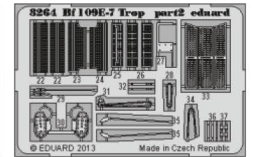

-Parts not for use. -Teile werden nicht verwendet. -Pièces à ne pas utiliser. -Tyto díly nepoužívejte při stavbě. - 使用しない部品

## COLOURS



## BARVY



## FARBEN



## PEINTURE



## 色

GSI Creos (GUNZE)		MISSION MODELS	
AQUEOUS	Mr.COLOR	PAINTS	
H2	C2	MMP-047	BLACK
H11	C62	MMP-001	FLAT WHITE
H12	C33	MMP-047	FLAT BLACK
H47	C41	MMP-012	RED BROWN
H51	C11	MMP-063	LIGHT GULL GRAY
H64	C17	MMP-087	RLM 71 DARK GREEN
H65	C18	MMP-088	RLM 70 BLACK GREEN
H66	C119	MMP-119	RLM 79 SAND YELLOW
H67	C115	MMP-057	RLM 65 LIGHT BLUE
H70	C60	MMP-056	RLM 02 GRAY
H77	C137	MMP-040	TIRE BLACK
H80	C54		KHAKI GREEN
H90	C47		CLEAR RED

GSI Creos (GUNZE)		MISSION MODELS	
AQUEOUS	Mr.COLOR	PAINTS	
H94	C138		GREEN
H413	C113	MMP-090	RLM 04 YELLOW
H414	C114		RLM 23 RED
H416	C116	MMP-088	RLM 66 BLACK GRAY
H417	C117	MMP-051	RLM 76 LIGHT BLUE
H418	C118	MMP-055	RLM 78 LIGHT BLUE
H420	C120	MMP-120	RLM 80 OLIVE GREEN
Mr.METAL COLOR		METALLICS	
MC213		MMM-006	STEEL
MC214		MMM-001	DARK IRON
MC218		MMM-003	ALUMINIUM
Mr.COLOR SUPER METALLIC		METALLICS	
SM01		MMC-001	SUPER CHROME

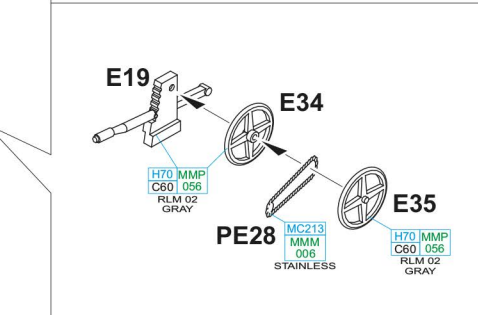
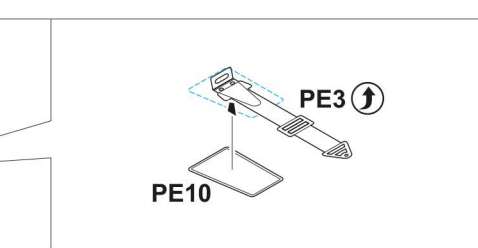
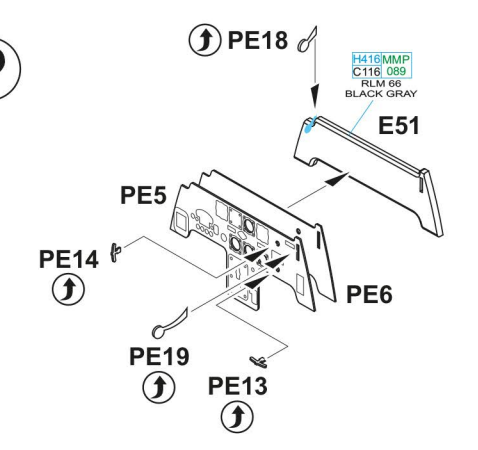
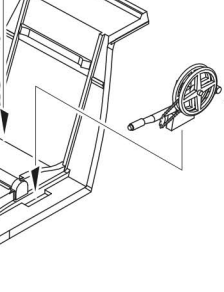
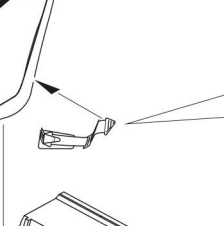
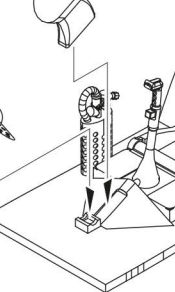
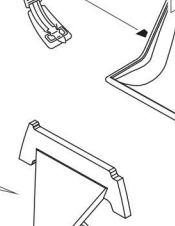
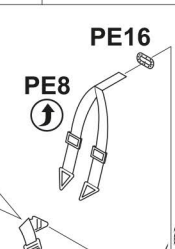
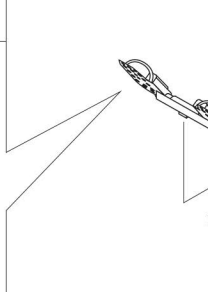
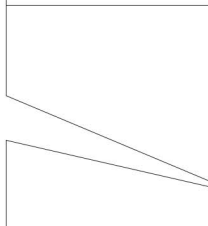
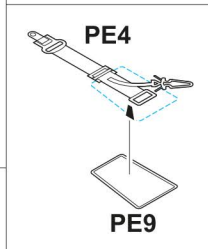
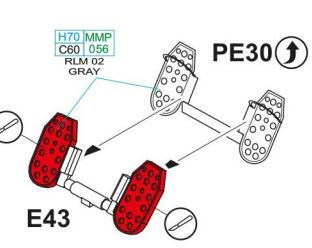
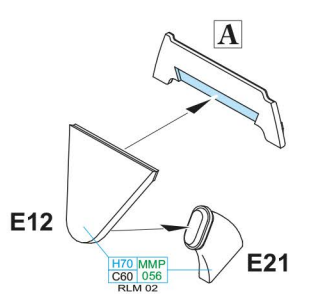
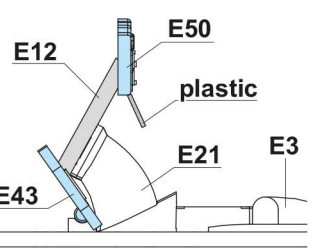
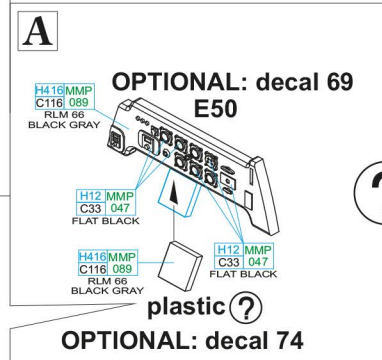
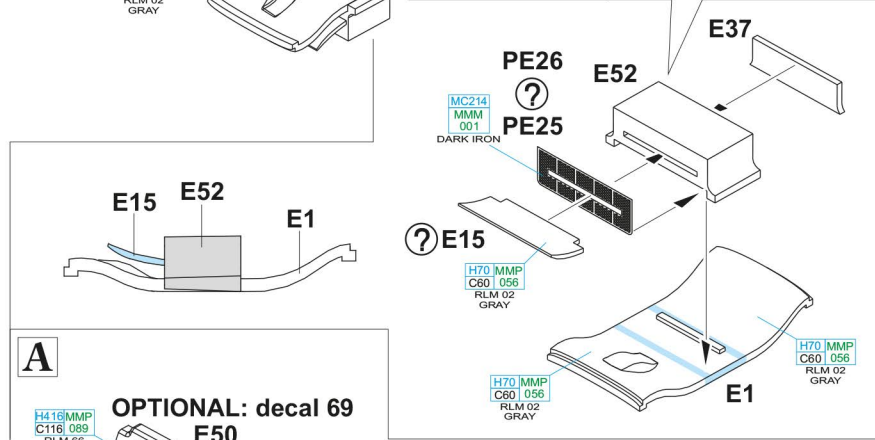
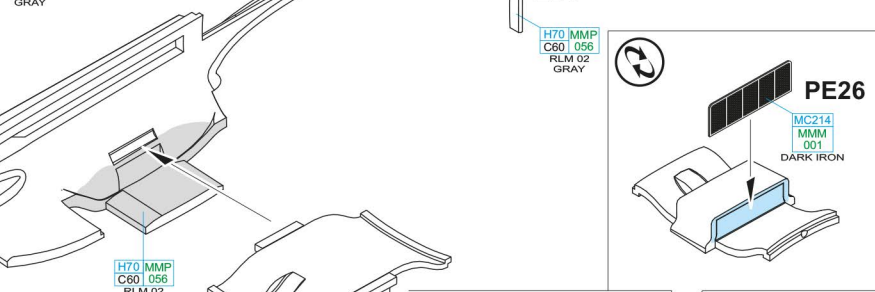
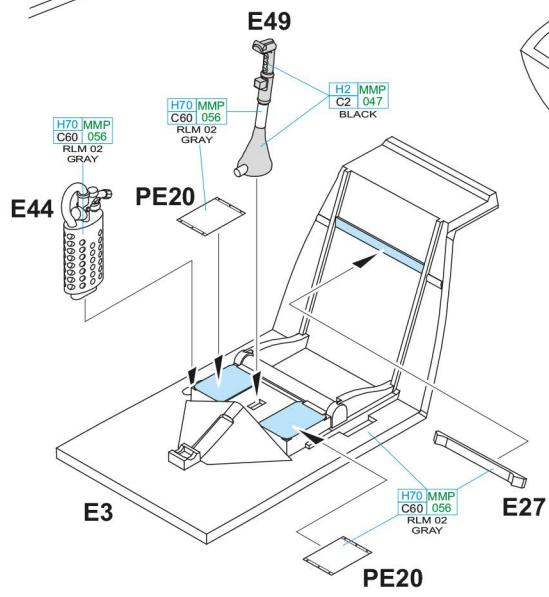
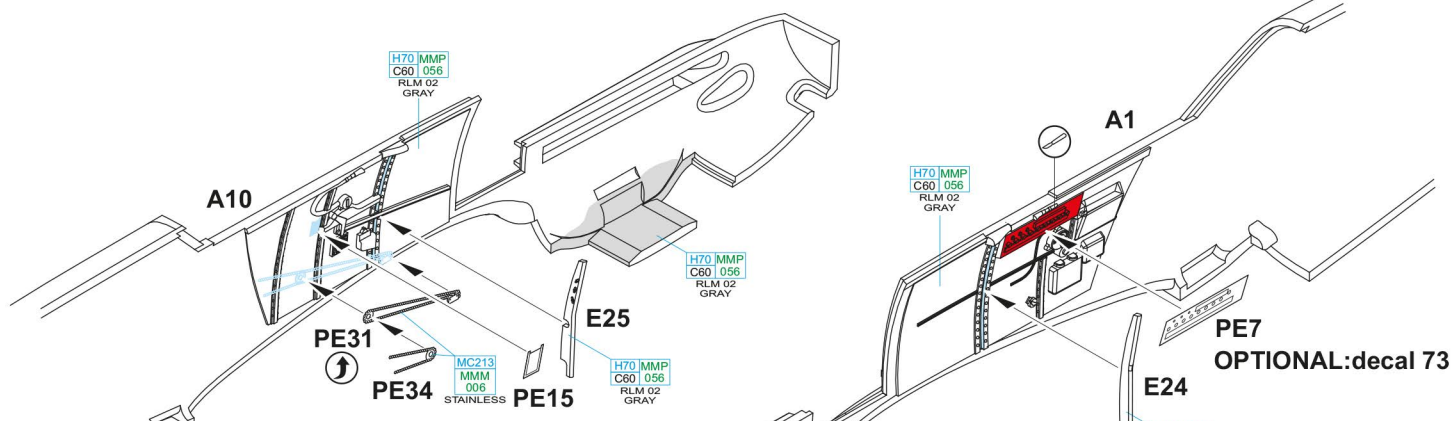

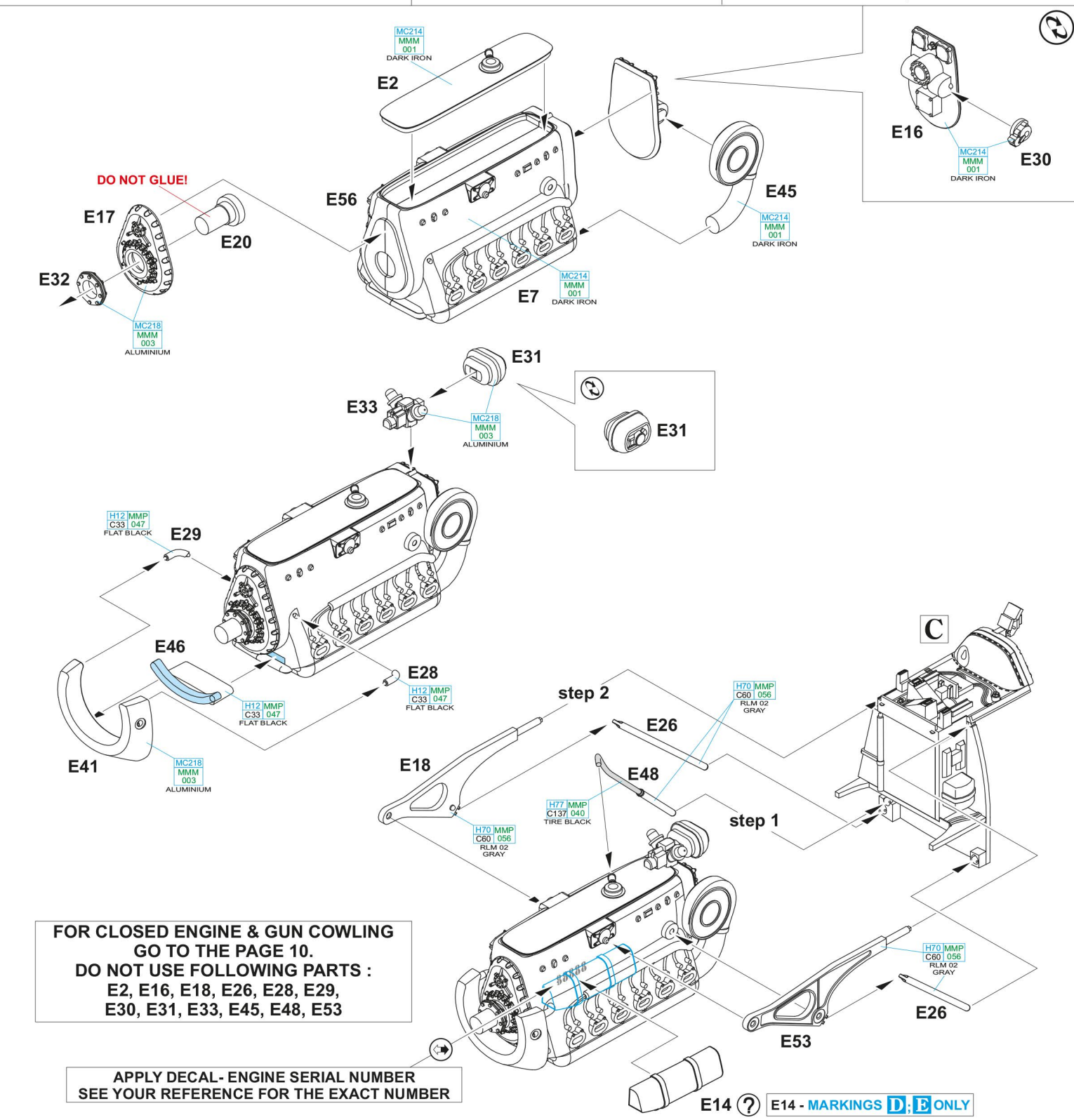
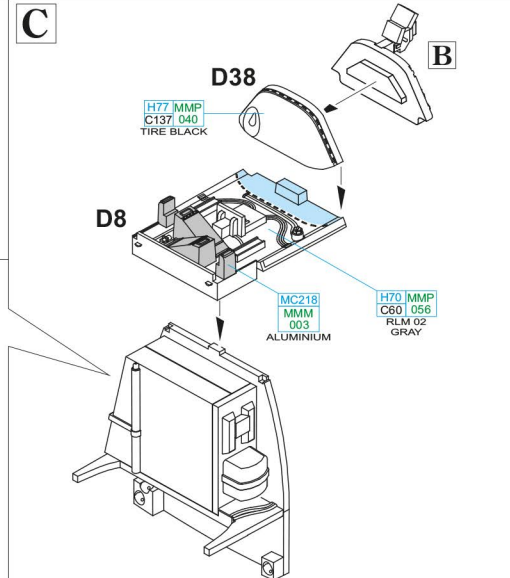
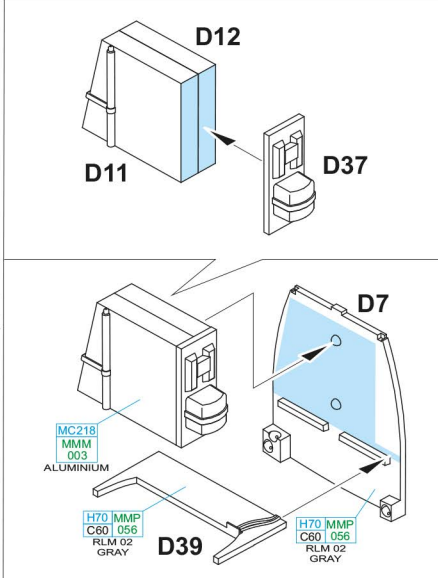
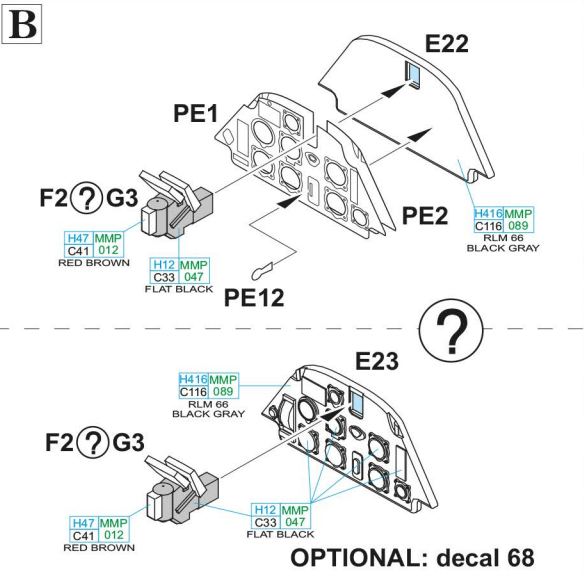

**FOR CLOSED ENGINE & GUN COWLING  
 GO TO THE PAGE 10.  
 DO NOT USE FOLLOWING PARTS :**  
**E2, E16, E18, E26, E28, E29,  
 E30, E31, E33, E45, E48, E53**

**APPLY DECAL- ENGINE SERIAL NUMBER  
 SEE YOUR REFERENCE FOR THE EXACT NUMBER**

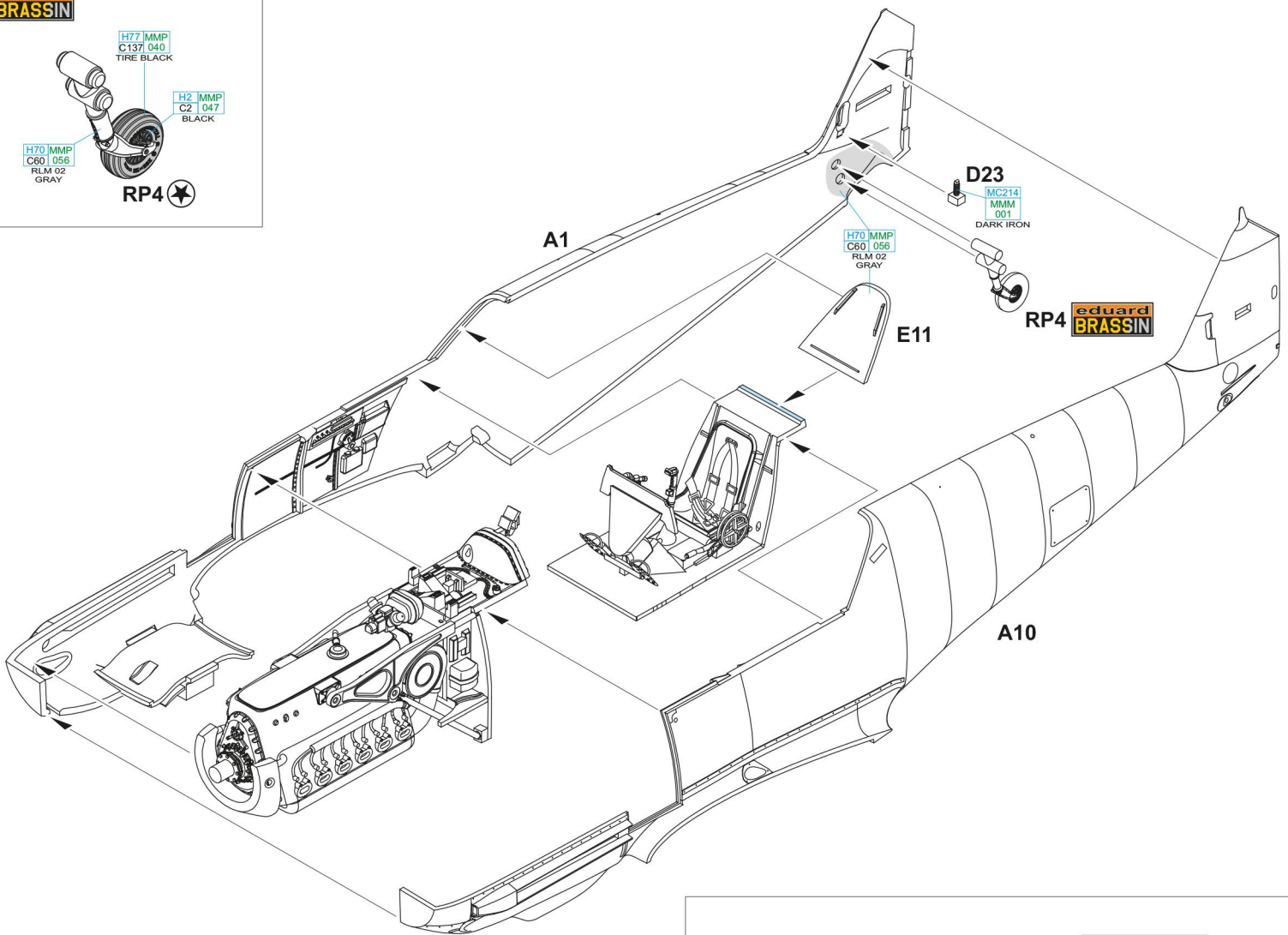
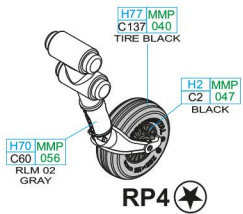

**OPEN NOSE**

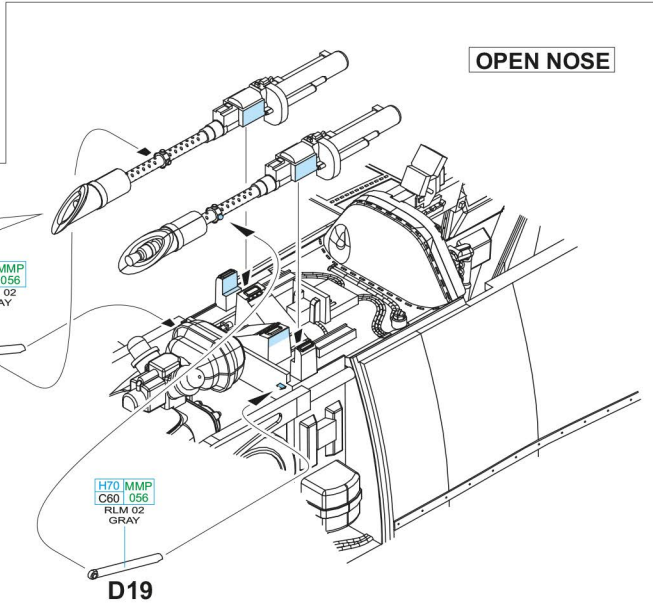

**2 pcs.**

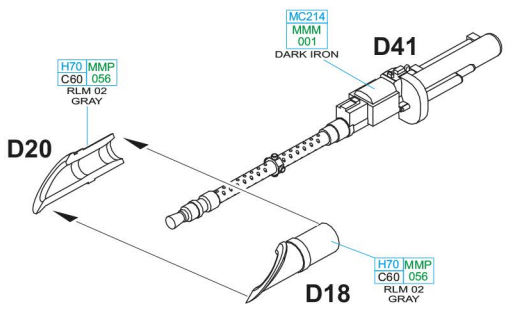

**EXHAUST PIPES INSTALATION**

**1.**

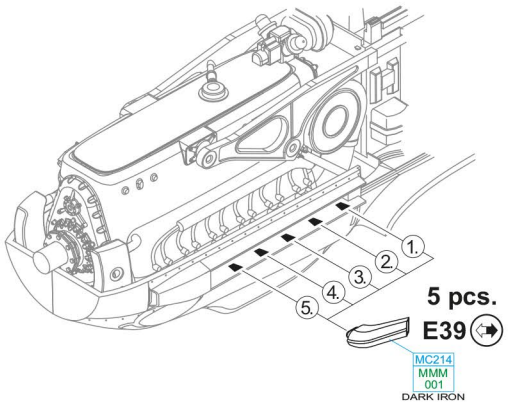

**2.**

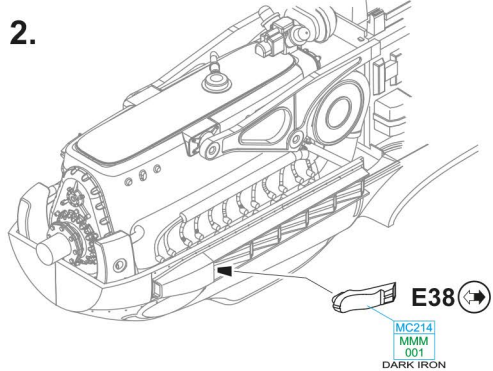

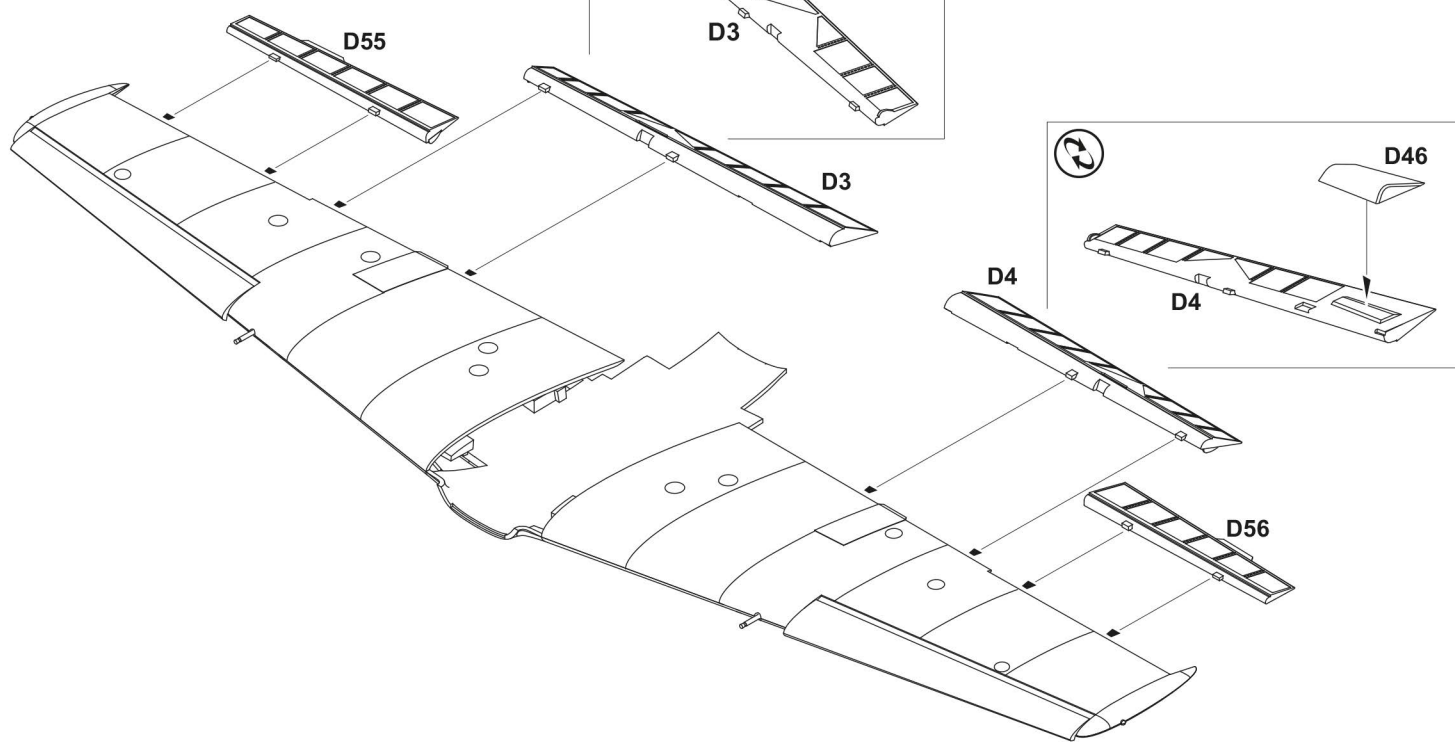
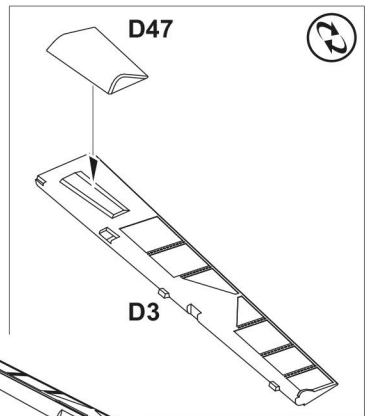
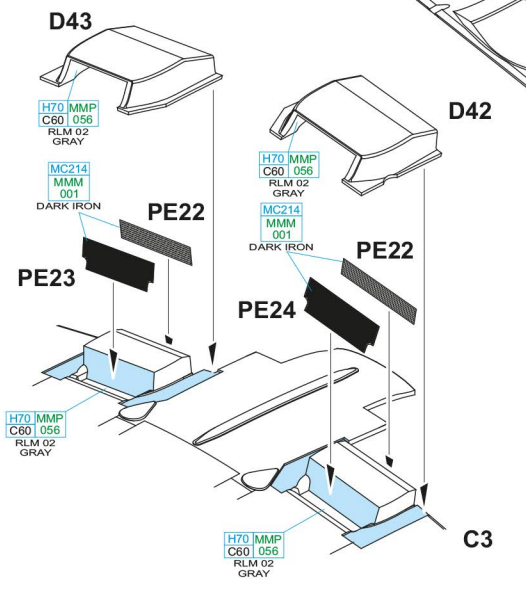
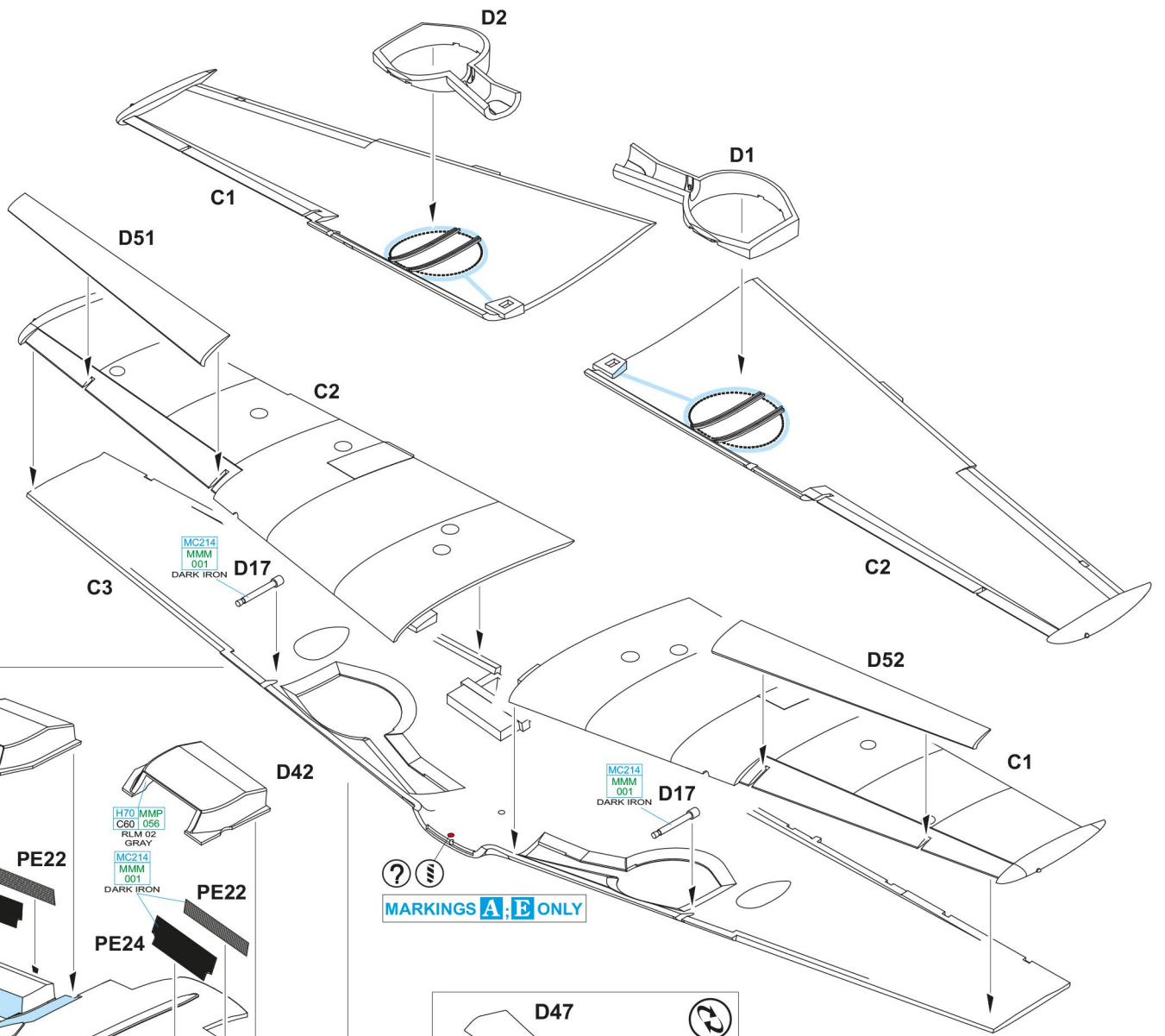

H84  
C138  
CLEAR GREEN

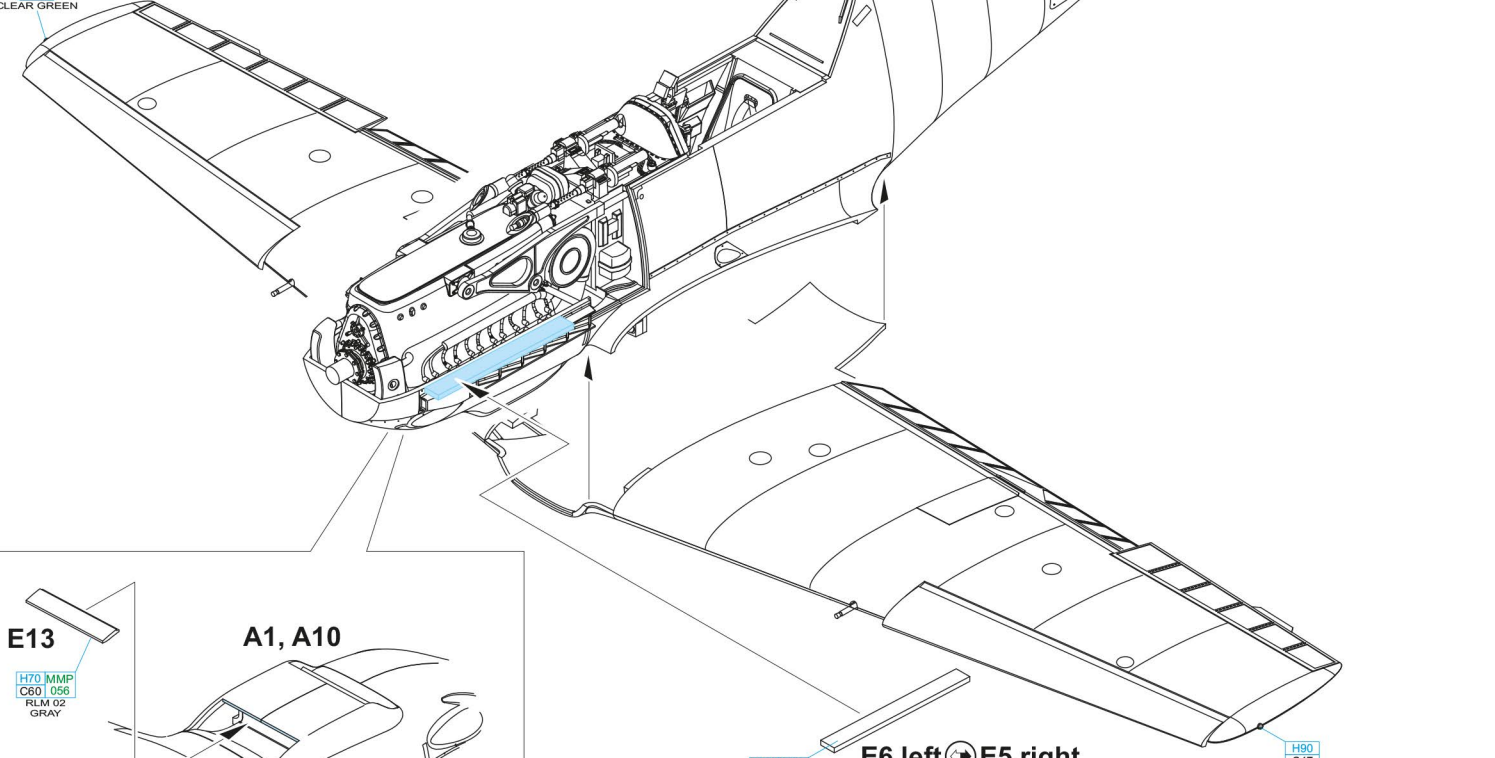

E13

A1, A10

H70 MMP  
C60 | 056  
RLM 02  
GRAY

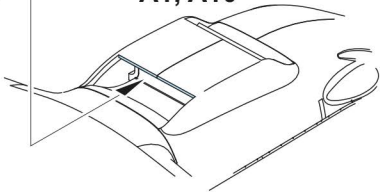

H70 MMP  
C60 | 056  
RLM 02  
GRAY

E6 left ↔ E5 right

H90  
C47  
CLEAR RED

D53

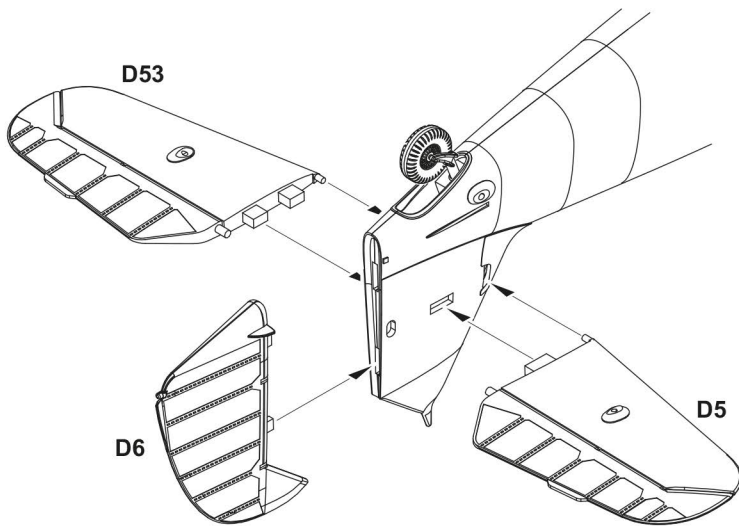

D5

D6

D13

D14

PE35 ↔

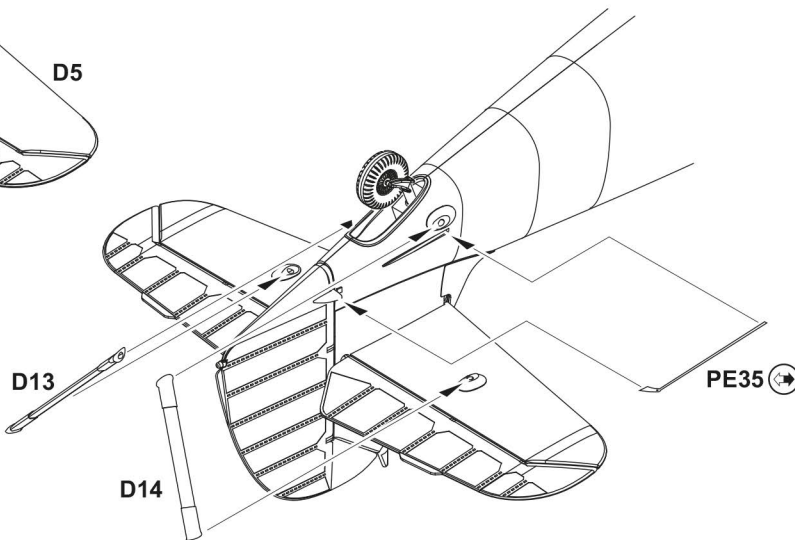

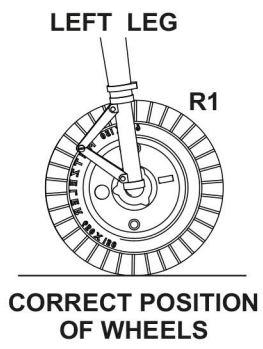
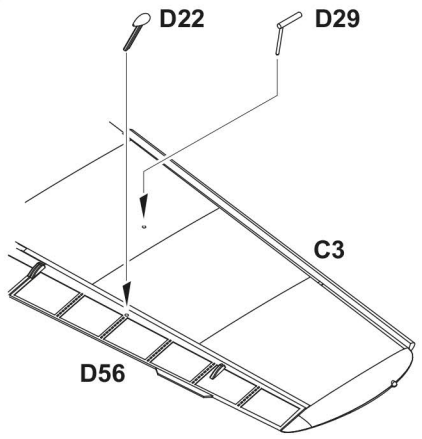

RP1 left (↔) RP2 right (★)

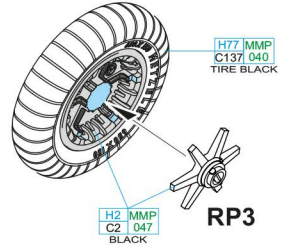

L (↔) R

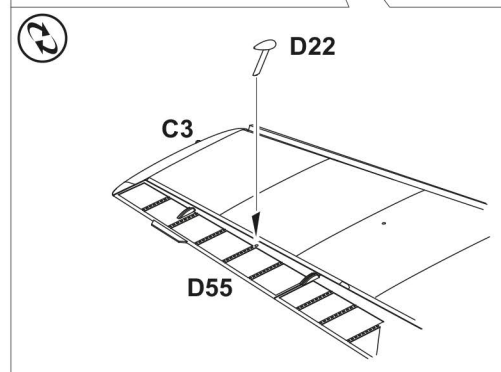
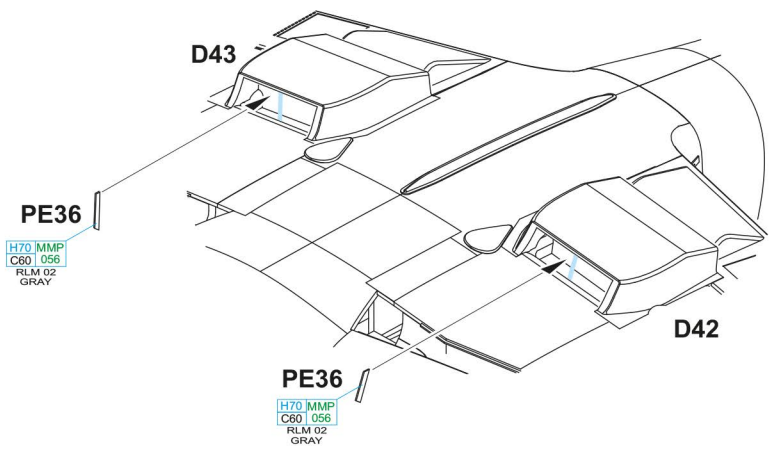
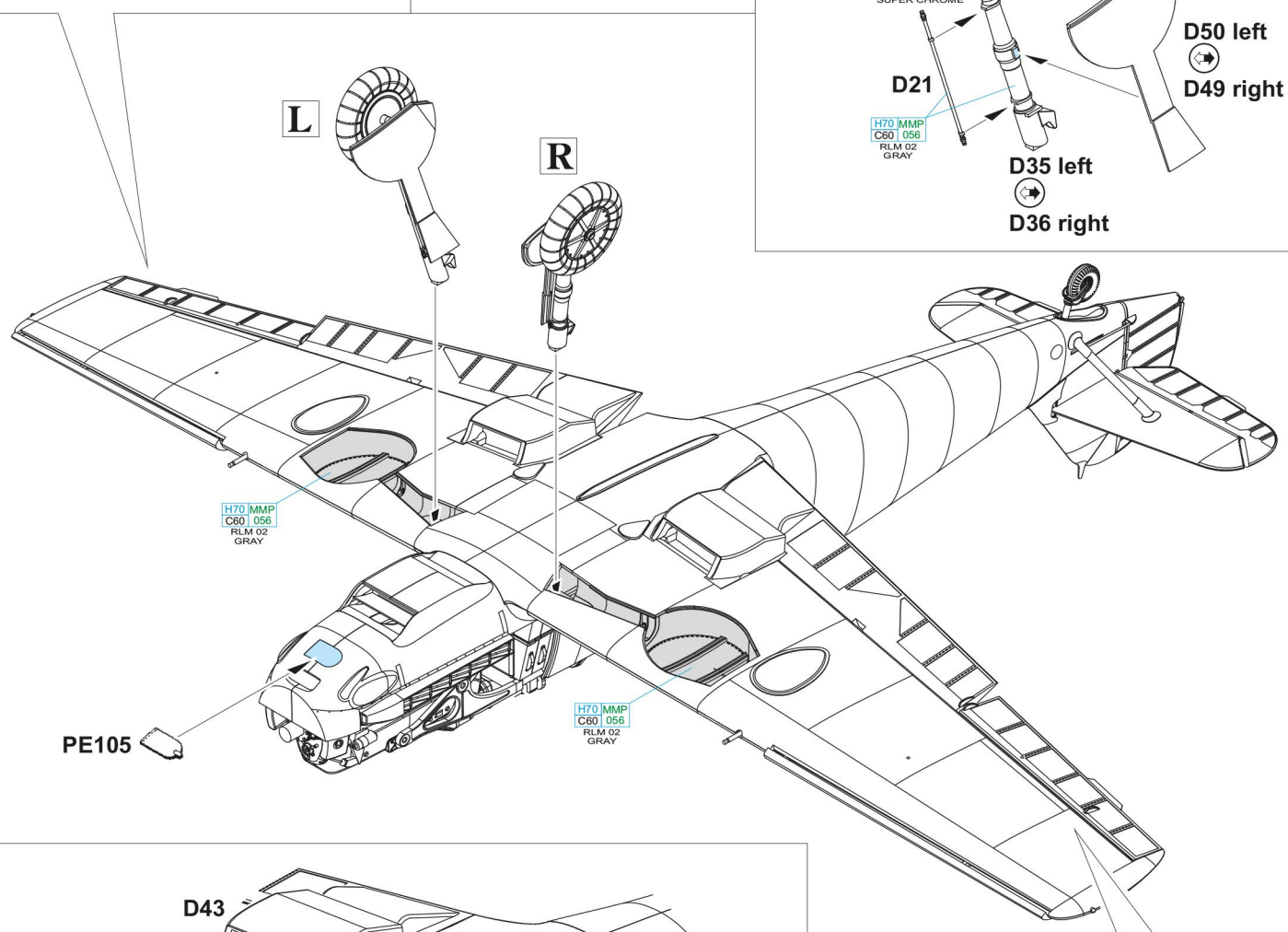
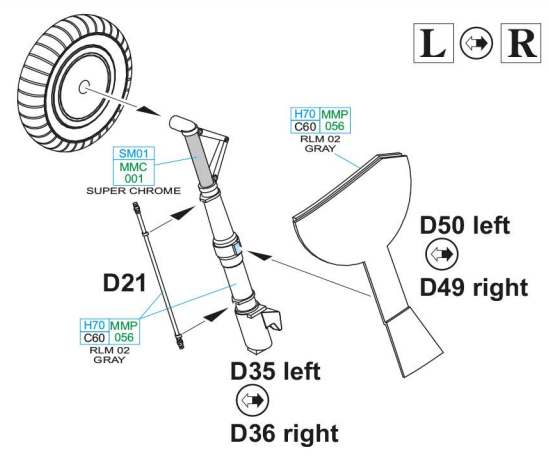

THE CORRECT POSITION OF THE UNDERCARRIAGE LEGS

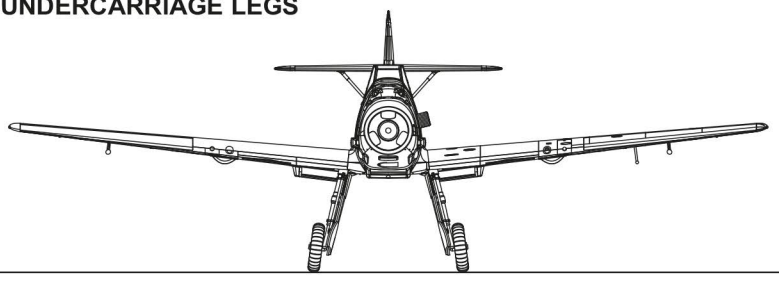
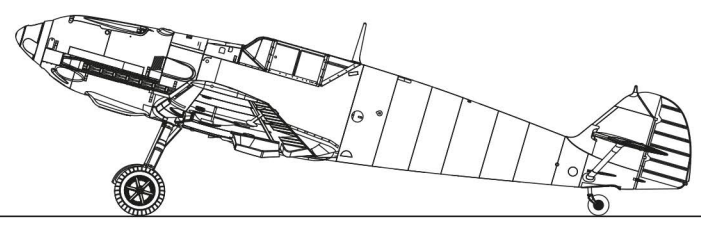



MARKINGS A, E ONLY

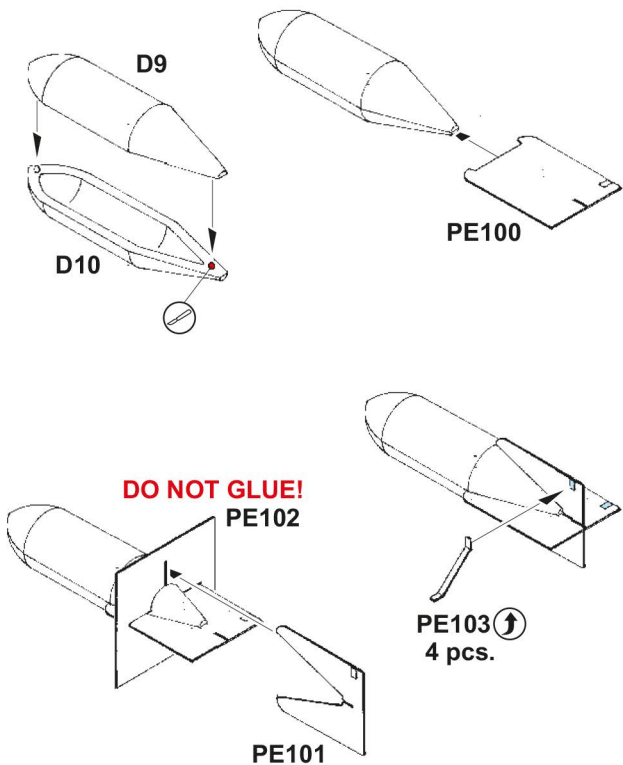

- H12 MMP C33 047 FLAT BLACK
- H51 MMP C11 083 GRAY
- H80 C54 KHAKI GREEN
- H70 MMP C60 056 RLM 02 GRAY

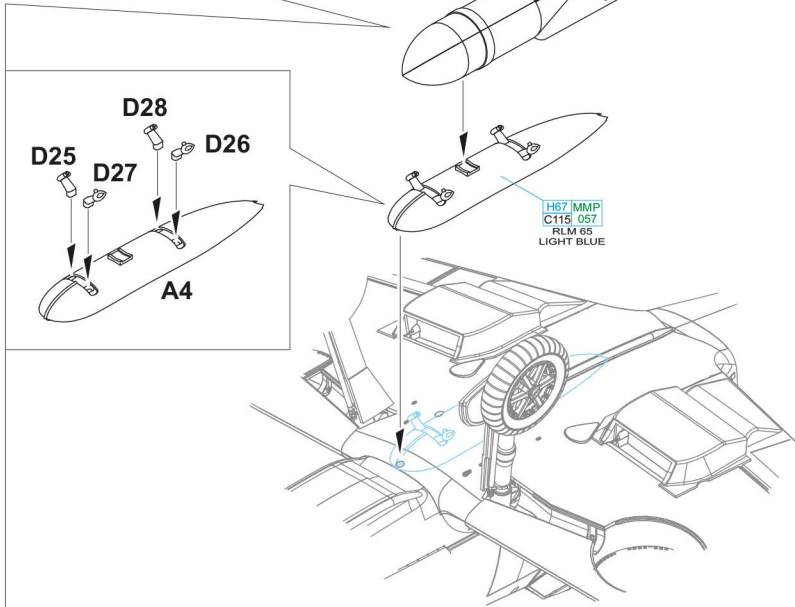

D

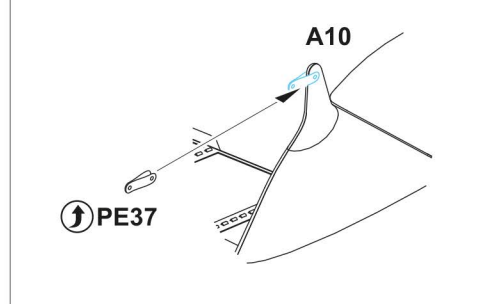
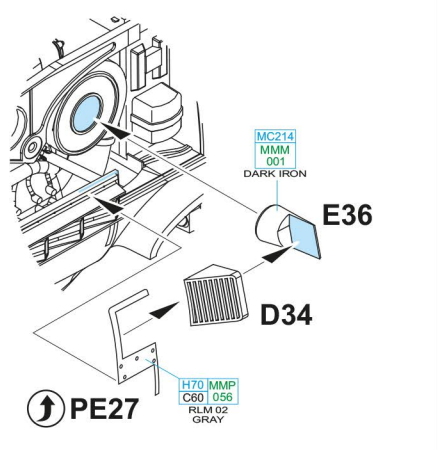

MARKING B ONLY

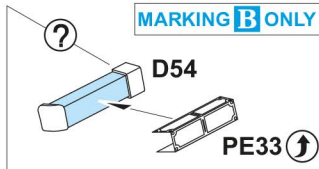

FOR CLOSED NOSE SEE PAGE 10

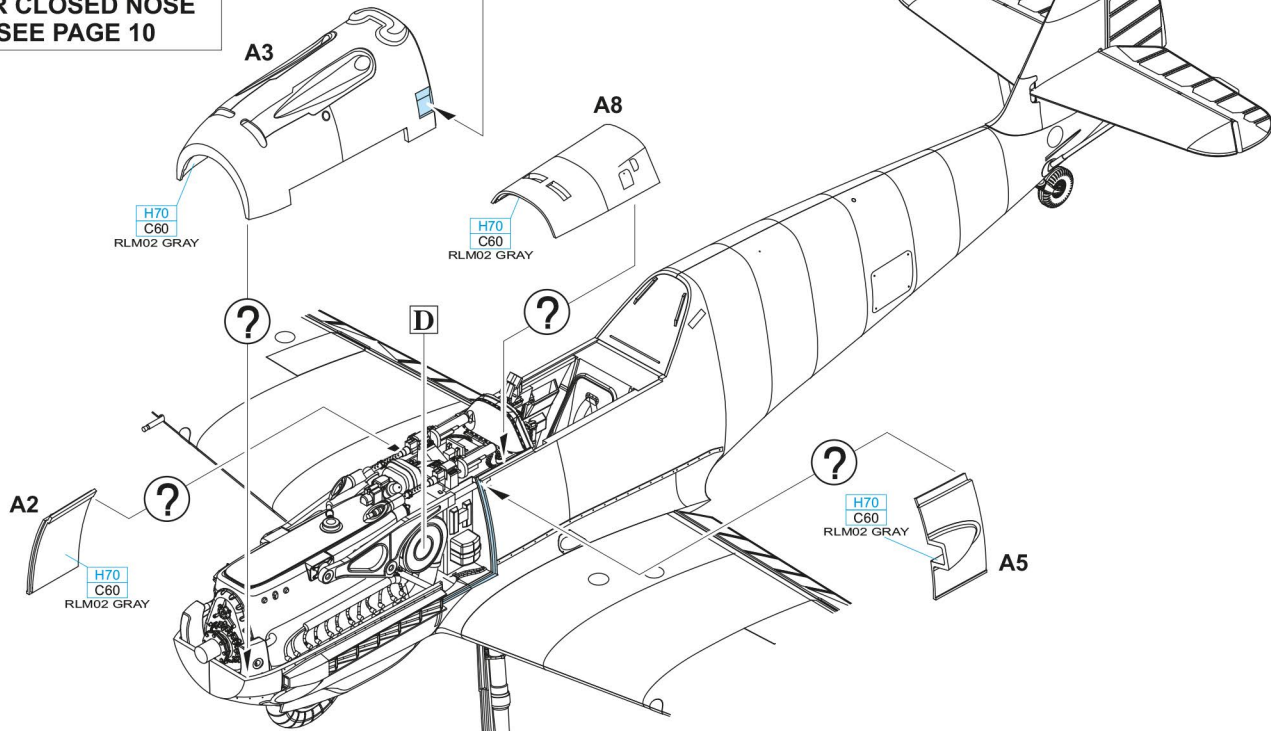

FOR CLOSED ENGINE COMPARTMENT ONLY

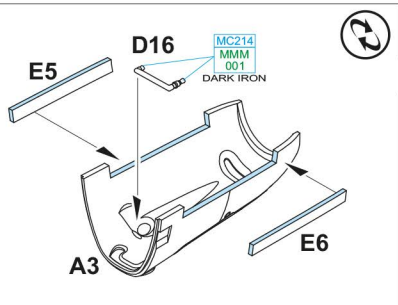
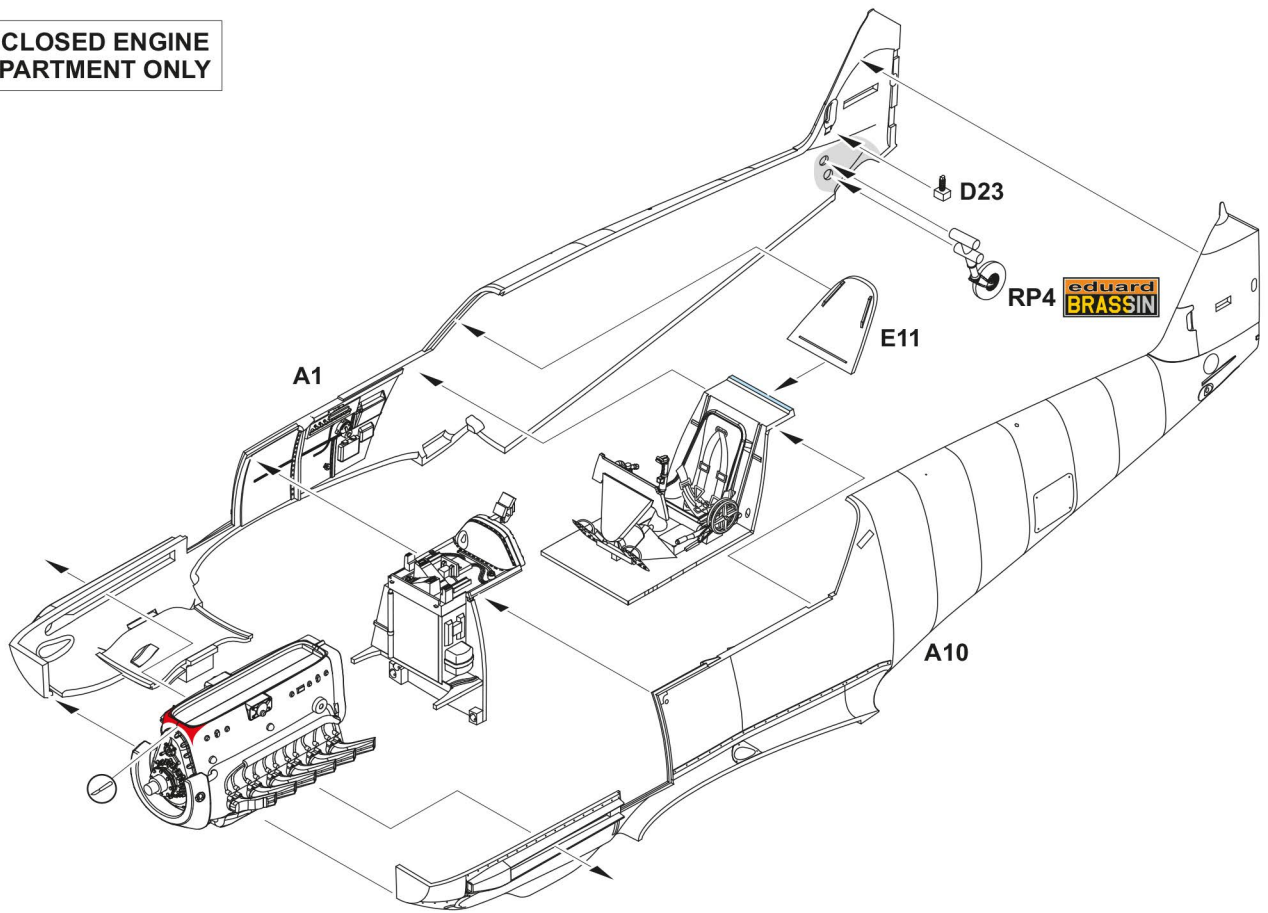

D34 - MARKINGS **A, C, D, E**  
D54, PE33 - MARKING **B**

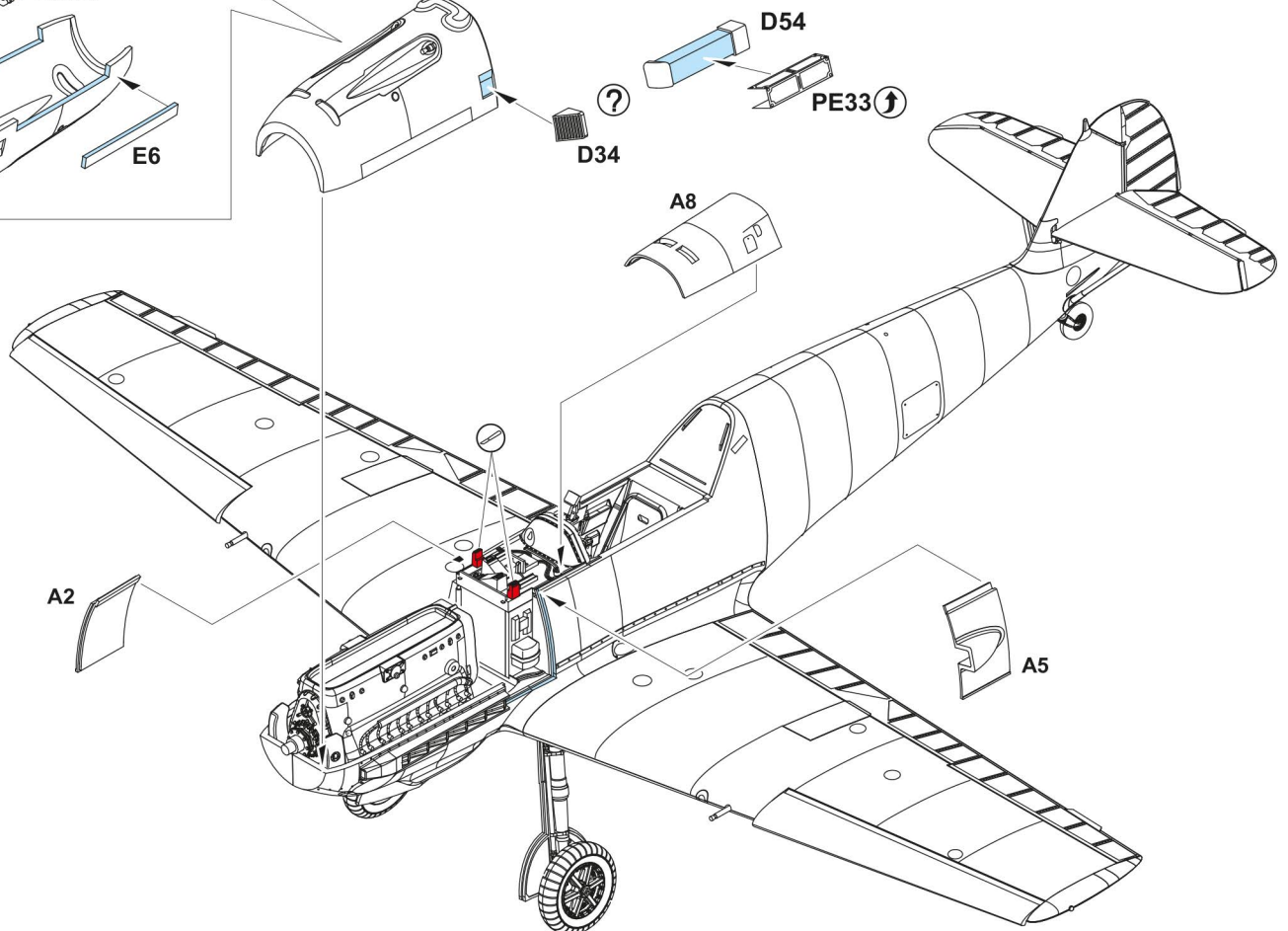

**E** MARKINGS **A,B,C,E**

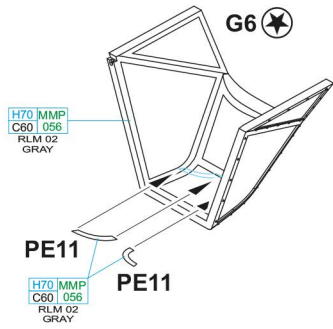

**F** MARKINGS **A,B,C,E**

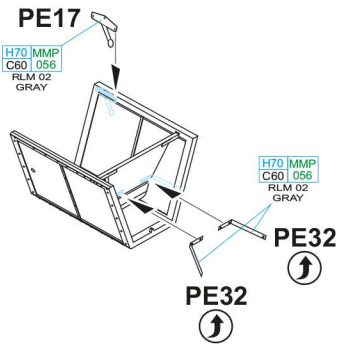
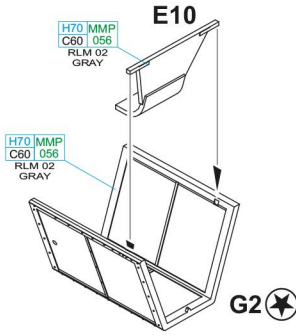

**MARKING D**

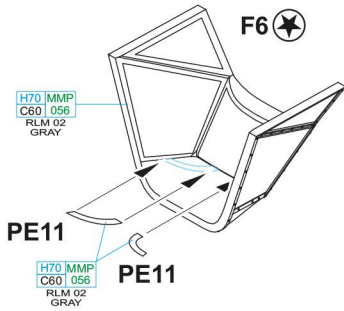

**MARKING D**

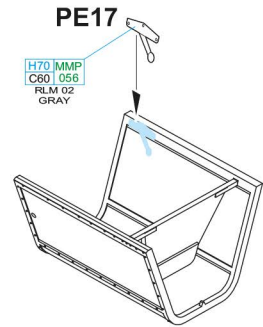
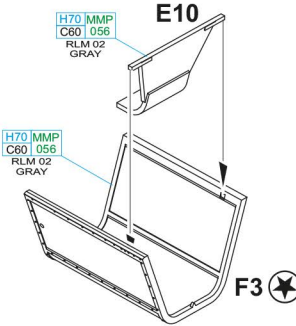

**OPEN**

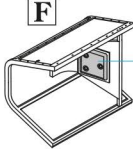

**H47 MMP C41 012 RED BROWN**

**F5 - MARKING D**  
**G7 - MARKINGS A,B,C,E**

**F5** (with a question mark) **G7** (with a star symbol)

**CLOSED**



**H70 C60 RLM02 GRAY**

**E**

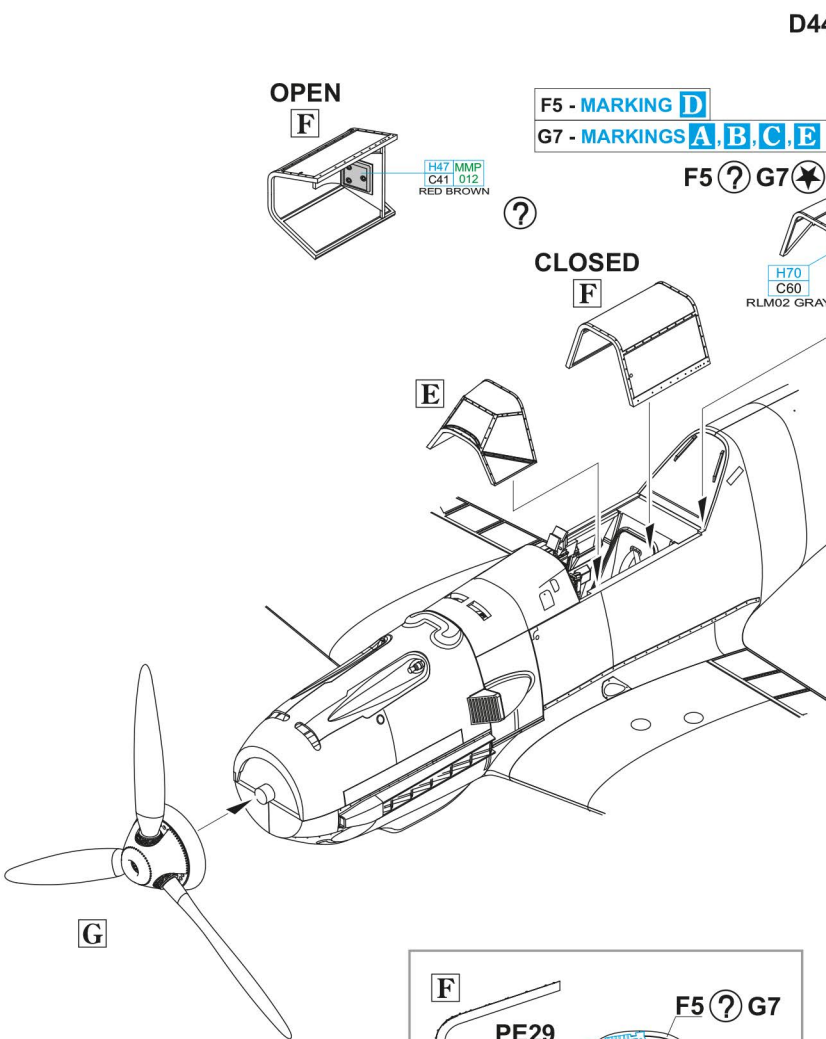

**G**

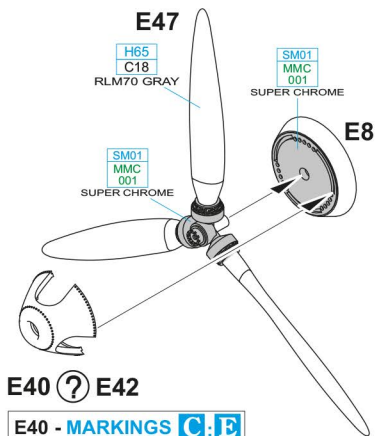

**E40** (with a question mark) **E42**

**E40 - MARKINGS C,E**  
**E42 - MARKINGS A,B,D**

**PE29** (with an upward arrow) **H12 C33 FLAT BLACK**

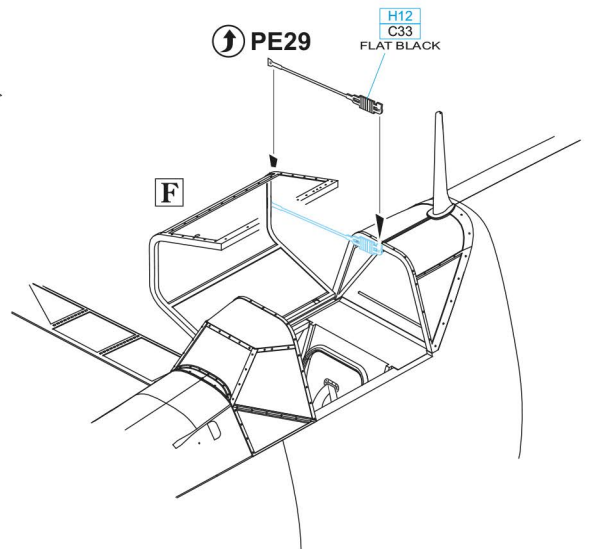

**PE29** (with an upward arrow) **F5** (with a question mark) **G7**

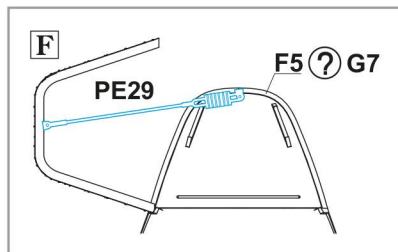



Carefully read instruction sheet before assembling. When you use glue or paint, do not use near open flame and use in well ventilated room. Keep out of reach of small children. Children must not be allowed to suck any part, or pull vinyl bag over the head.



Před započetím stavby si pečlivě prostudujte stavební návod. Při používání barev a lepidel pracujte v dobře větrané místnosti. Lepidla ani barvy nepoužívejte v blízkosti otevřeného ohně. Model není určen malým dětem, mohlo by dojít k požití drobných dílů.

## INSTRUCTION SIGNS \* INSTR. SYMBOLY \* INSTRUKTION SINNBILDEN \* SYMBOLES \* 記号の説明

OPTIONAL  
VOLBABEND  
OHNOUTSAND  
BROUSITOPEN HOLE  
VYVRTAT OTVORSYMETRICAL ASSEMBLY  
SYMETRICKÁ MONTÁŽREMOVE  
ODŘÍZNOUTREVERSE SIDE  
OTOČITAPPLY EDUARD MASK  
AND PAINT  
POUŽIT EDUARD MASK  
NABARVIT

## PARTS



## DÍLY



## TEILE



## PIÈCES



## 部品

## PLASTIC PARTS

H&gt;

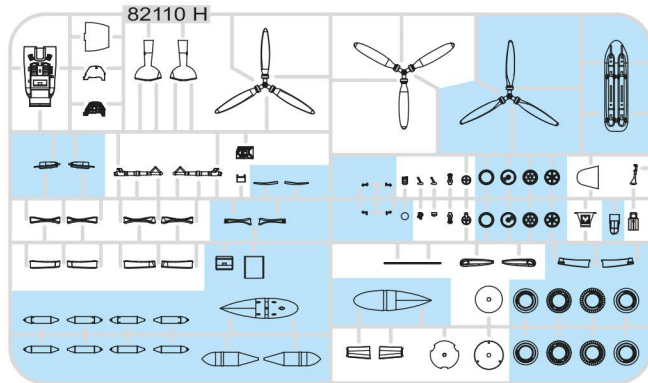

I&gt;

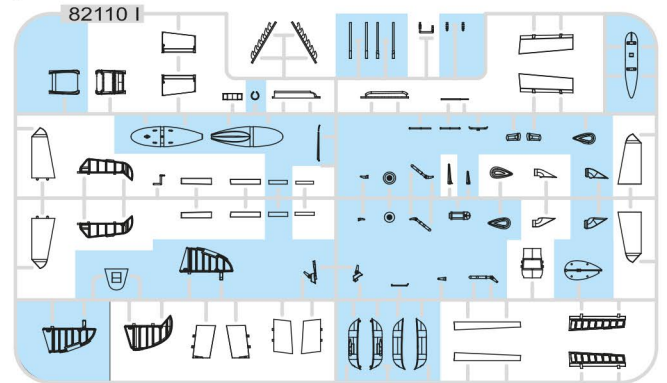

M&gt;

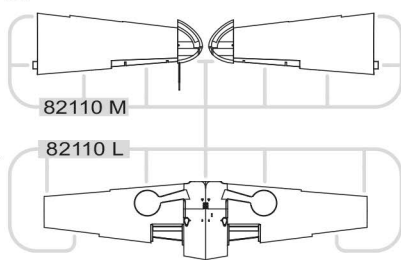

Q&gt;

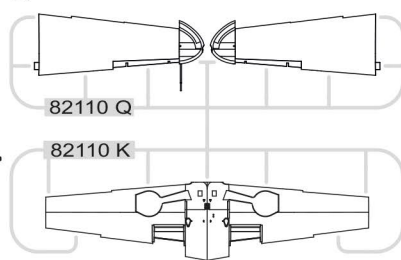

R&gt;

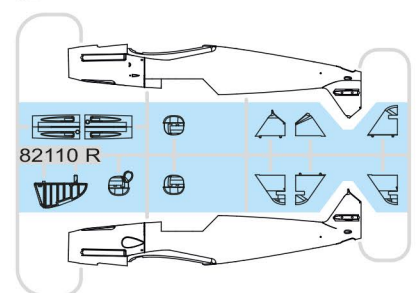

Z&gt;

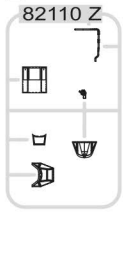

L&gt;

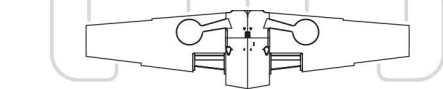

K&gt;

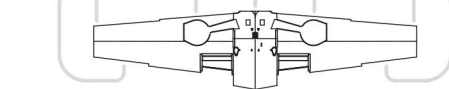

## PE - PHOTO ETCHED DETAIL PARTS

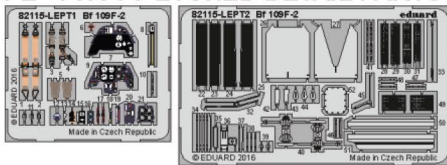

## Bf 109F-2

## RP - RESIN PARTS

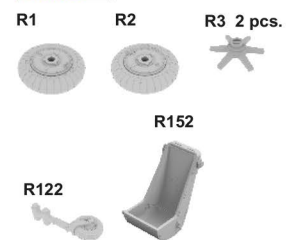

-Parts not for use. -Teile werden nicht verwendet. -Pièces à ne pas utiliser. -Tyto díly nepoužívejte při stavbě. - 使用しない部品

## COLOURS



## BARVY



## FARBEN



## PEINTURE



## 色

GSI Creos (GUNZE)		MISSION MODELS	
AQUEOUS	Mr.COLOR	PAINTS	
H2	C2	MMP-047	BLACK
H11	C62	MMP-001	FLAT WHITE
H12	C33	MMP-047	FLAT BLACK
H15	C65		BRIGHT BLUE
H47	C41	MMP-012	RED BROWN
H64	C17	MMP-087	RLM 71 DARK GREEN
H65	C18	MMP-088	RLM 70 BLACK GREEN
H67	C115	MMP-057	RLM 65 LIGHT BLUE
H68	C36	MMP-049	RLM 74 DARK GRAY
H69	C37	MMP-050	RLM 75 GRAY
H70	C60	MMP-056	RLM 02 GRAY
H77	C137	MMP-040	TIRE BLACK

GSI Creos (GUNZE)		MISSION MODELS	
AQUEOUS	Mr.COLOR	PAINTS	
H79	C39		SANDY YELLOW
H90	C47		CLEAR RED
H94	C138		CLEAR GREEN
H303	C303	MMP-066	GREEN
H413	C113	MMP-090	RLM 04 YELLOW
H416	C116	MMP-088	RLM 66 BLACK GRAY
H417	C117	MMP-051	RLM 76 LIGHT BLUE
Mr.METAL COLOR		METALLICS	
MC213		MMM-006	STEEL
MC214		MMM-001	DARK IRON
Mr.COLOR SUPER METALLIC		METALLICS	
SM01		MMC-001	SUPER CHROME

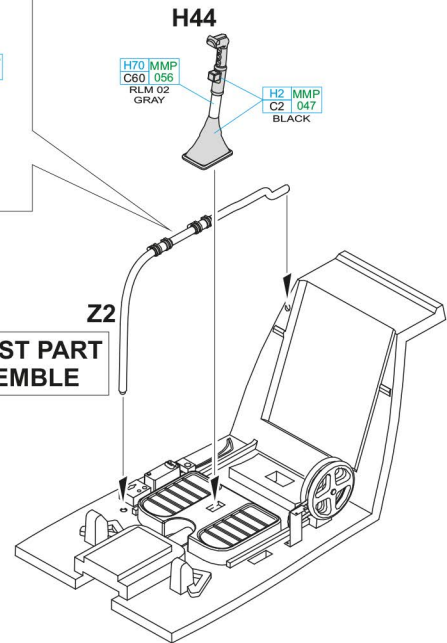
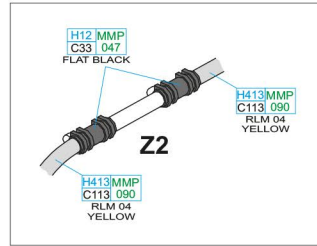
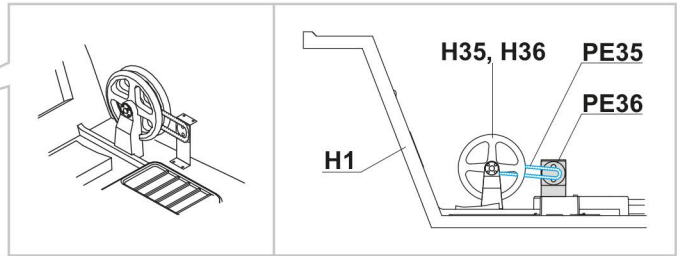
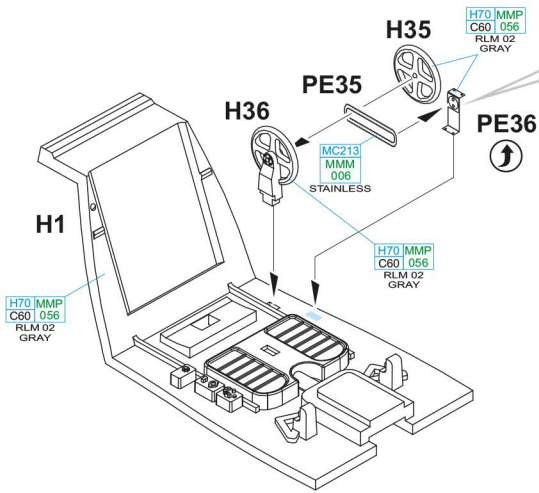

THE LATEST PART TO ASSEMBLE

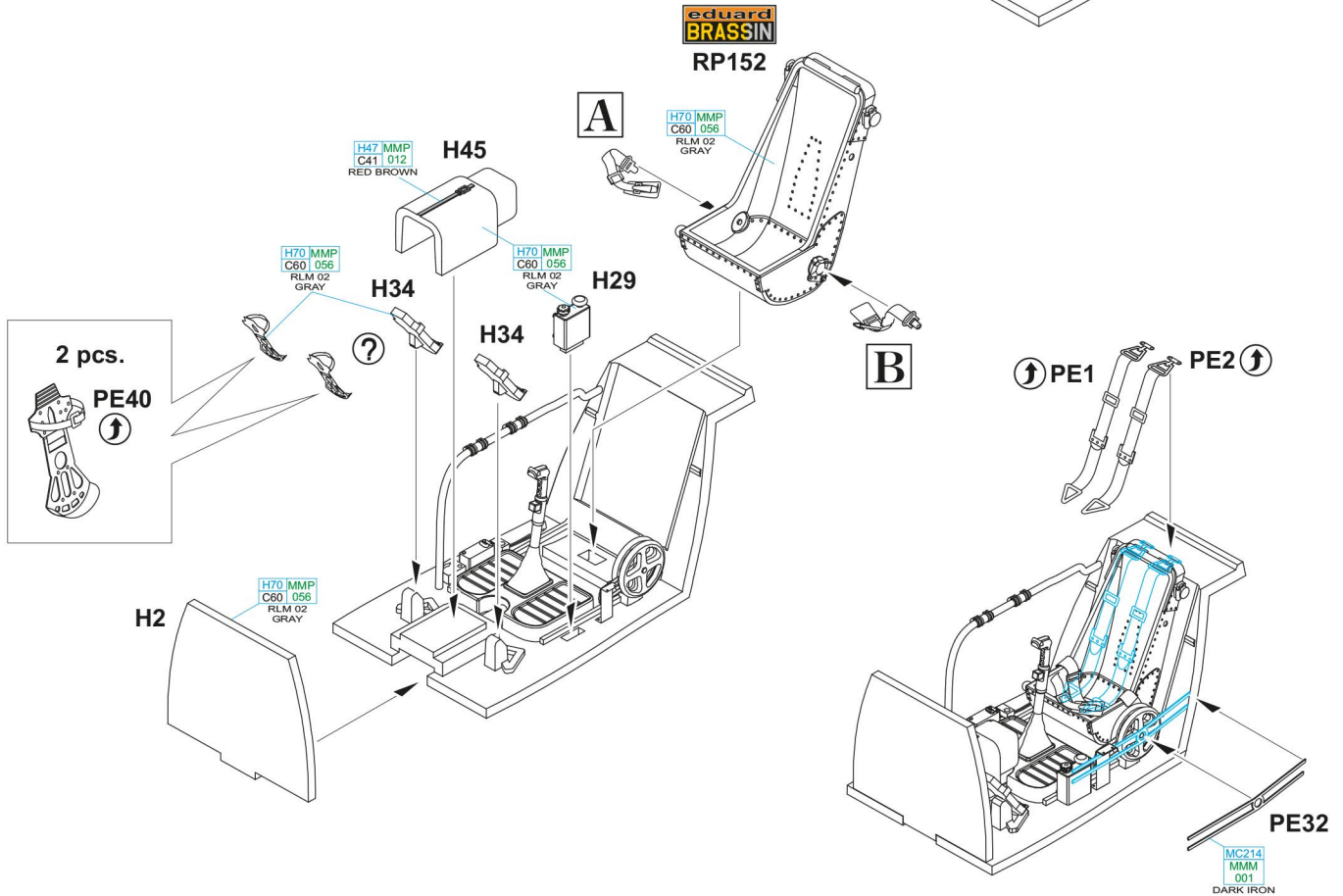
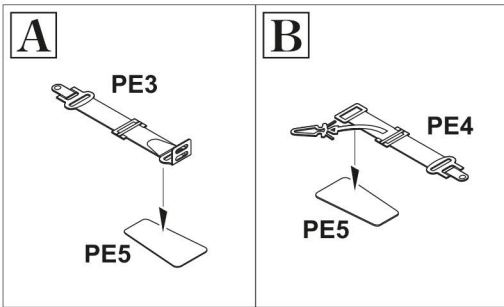

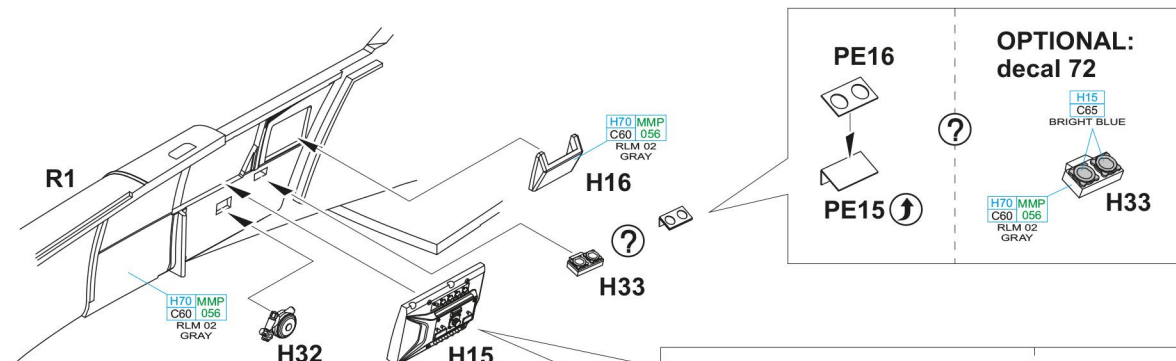

PE16

PE15 ↕

OPTIONAL:  
decal 72

H15  
C65  
BRIGHT BLUE

H33

H70 MMP  
C60 056  
RLM 02  
GRAY

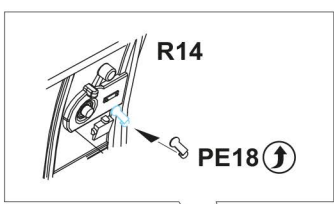

H32

H15  
C65  
BRIGHT BLUE

PE12

OPTIONAL:  
decal 71

H15

PE19

PE20

PE14

H15

decal 75

decal 76

decal 70

H70 MMP  
C60 056  
RLM 02  
GRAY

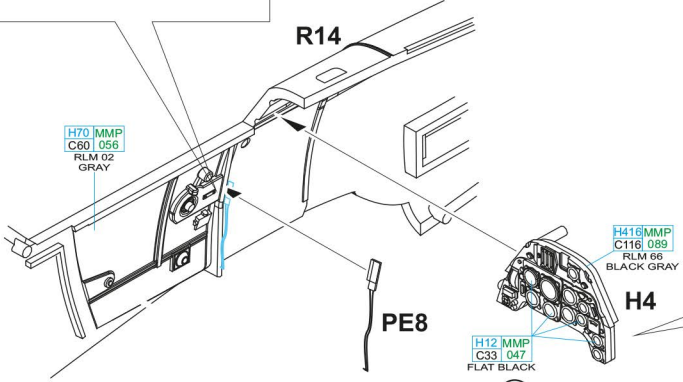

H3

PE7

PE9

PE6

PE21

H416 MMP  
C116 089  
RLM 66  
BLACK GRAY

OPTIONAL: decal 67

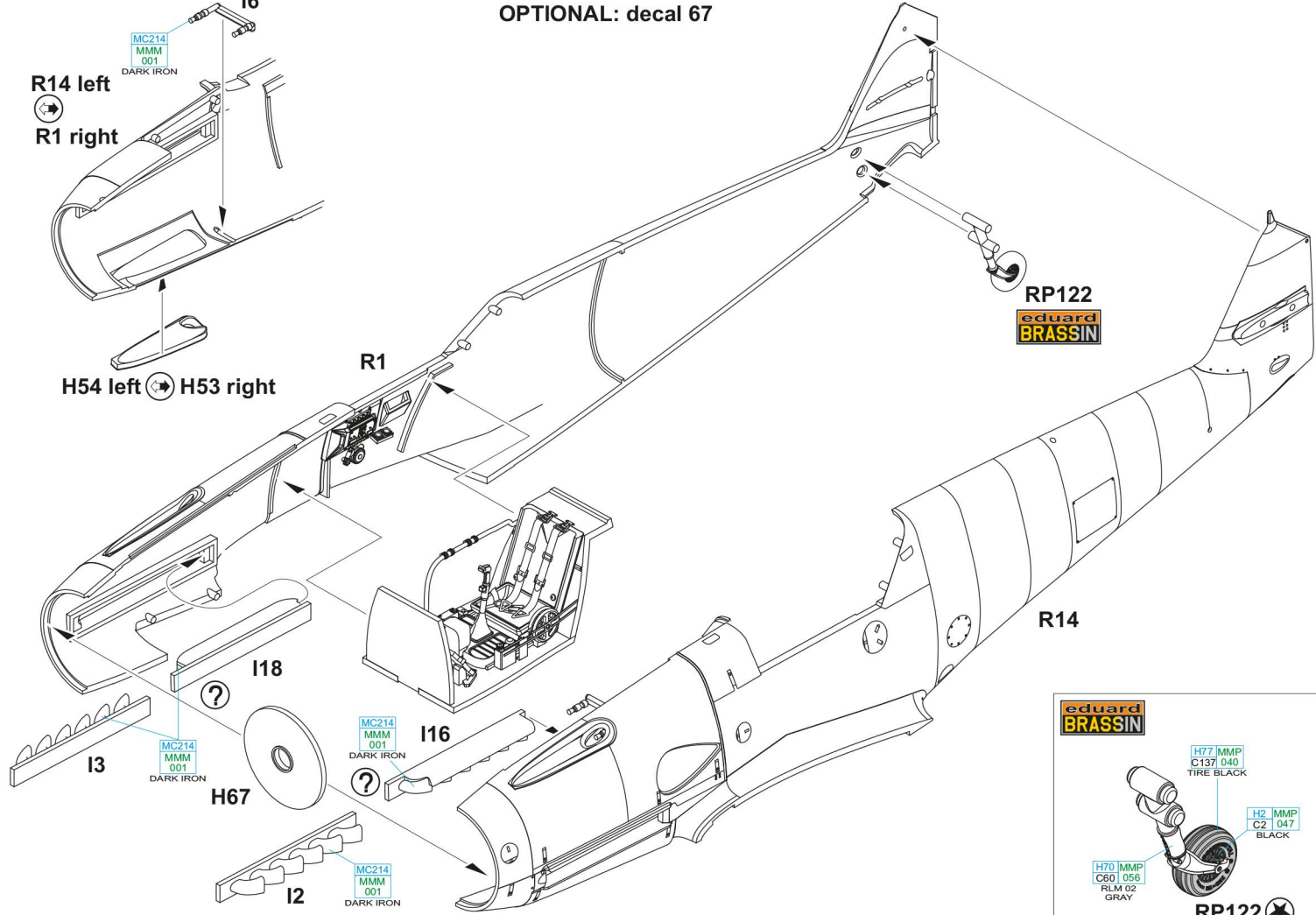
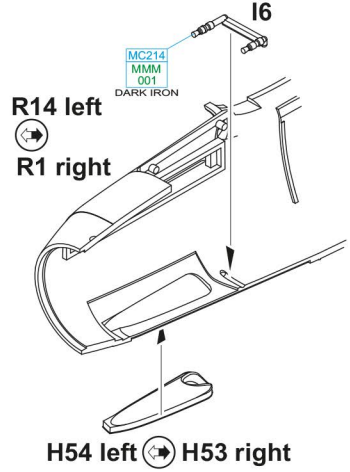

eduard  
BRASSIN

H77 MMP  
C137 040  
TIRE BLACK

H2 MMP  
C2 047  
BLACK

H70 MMP  
C60 056  
RLM 02  
GRAY

RP122

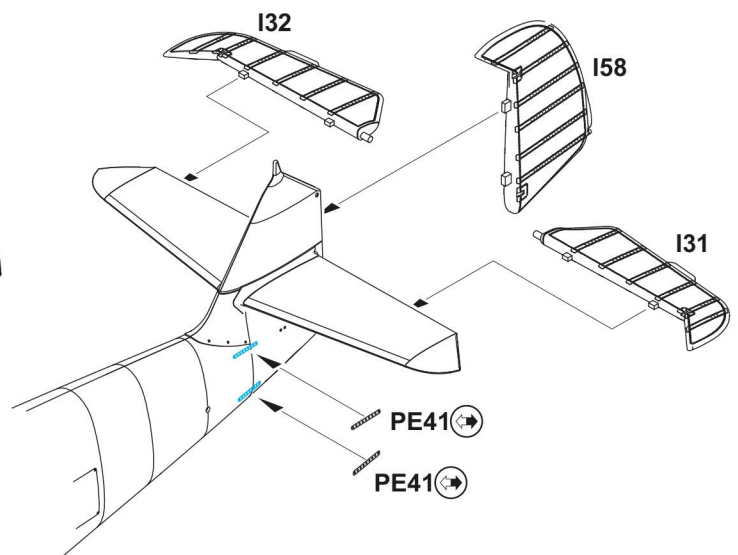
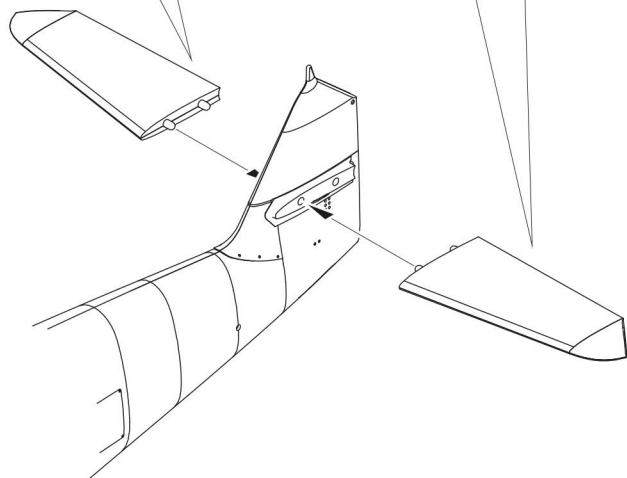
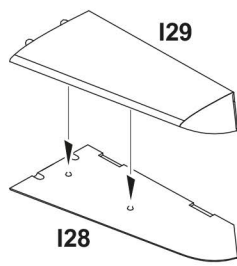
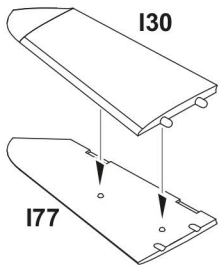
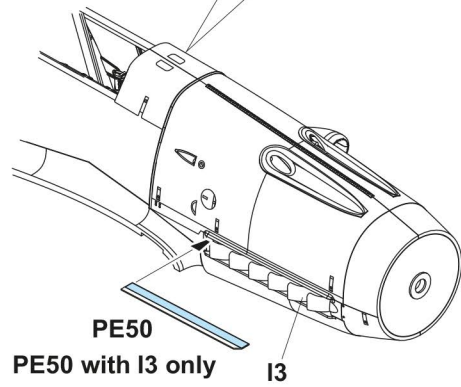
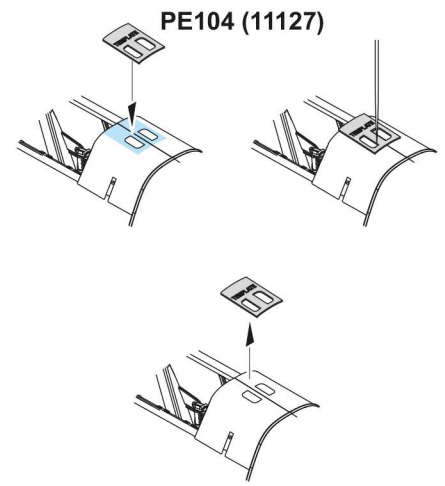
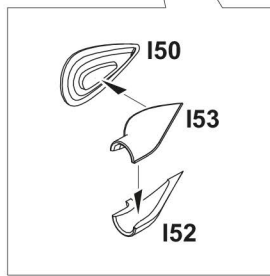
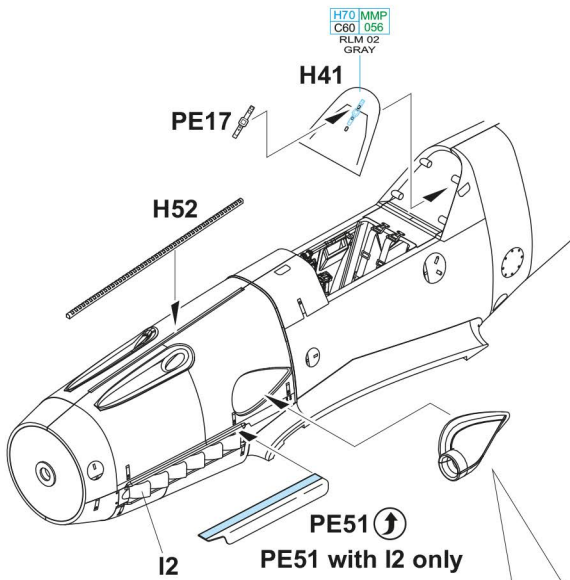

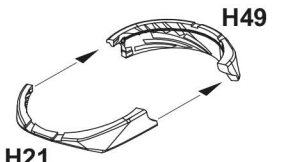
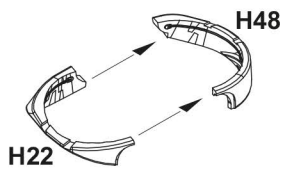

H77 MMP  
C137 040  
TIRE BLACK

MARKINGS F - I ONLY

H64

H70 MMP  
C80 056  
RLM02 GRAY

H63

step 1

step 1

H77 MMP  
C137 040  
TIRE BLACK

step 3

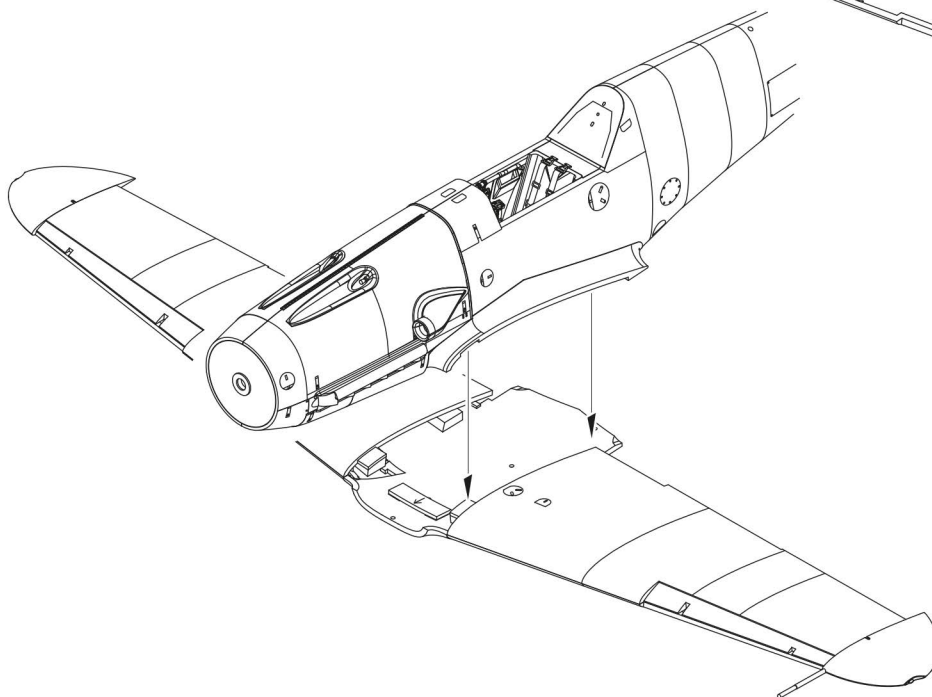
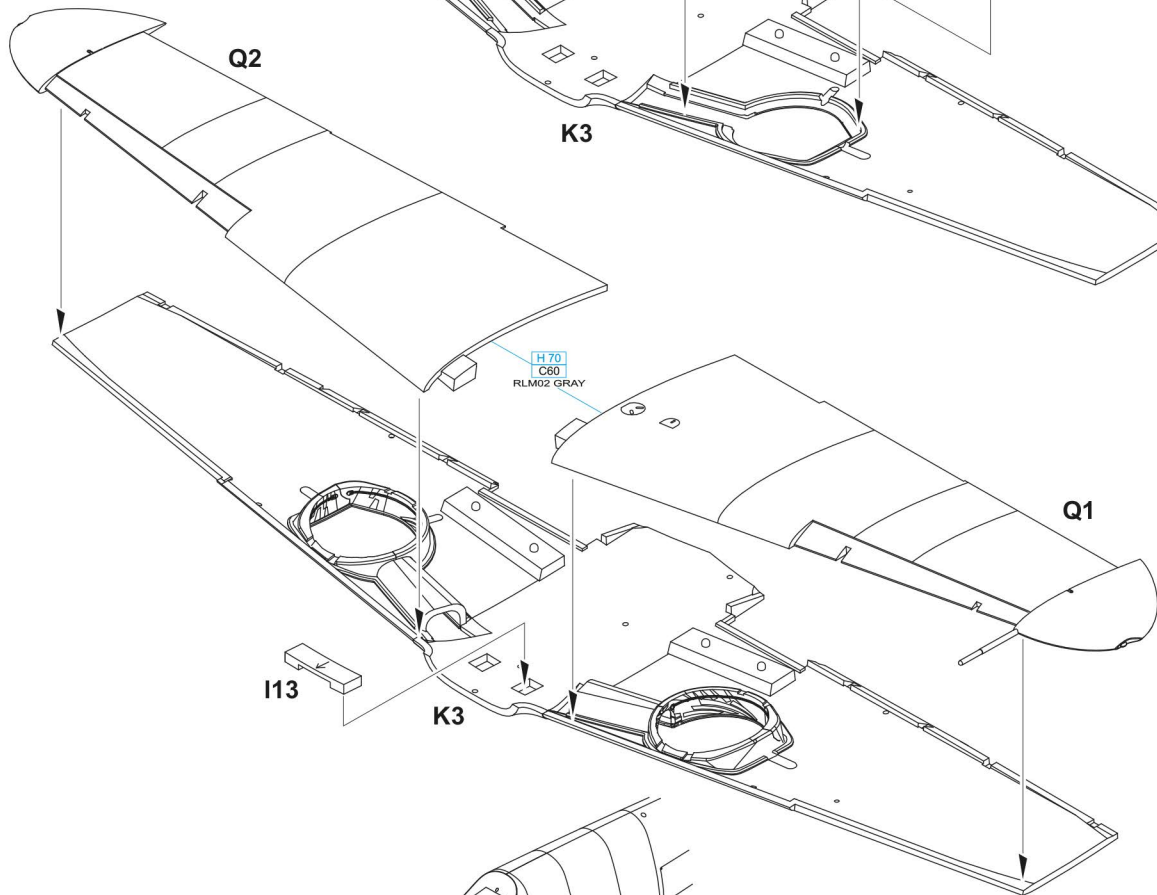



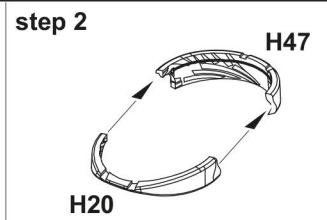
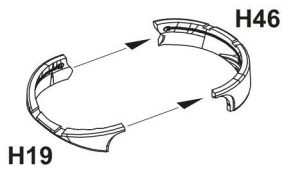

H77 MMP  
C137 040  
TIRE BLACK

MARKINGS J : K ONLY

H64

H70 MMP  
C80 056  
RLM 02  
GRAY

H63

H77 MMP  
C137 040  
TIRE BLACK

step 1

step 1

step 3

Q2 - MARKING J  
M2 - MARKING K

Q2 ? M2

L3

H70  
C60  
RLM02 GRAY

Q1 - MARKING J  
M1 - MARKING K

Q1 ? M1

L3

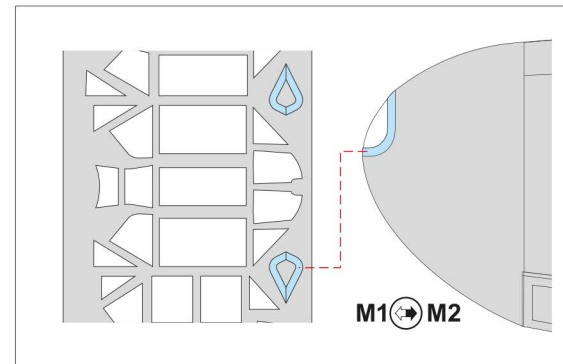
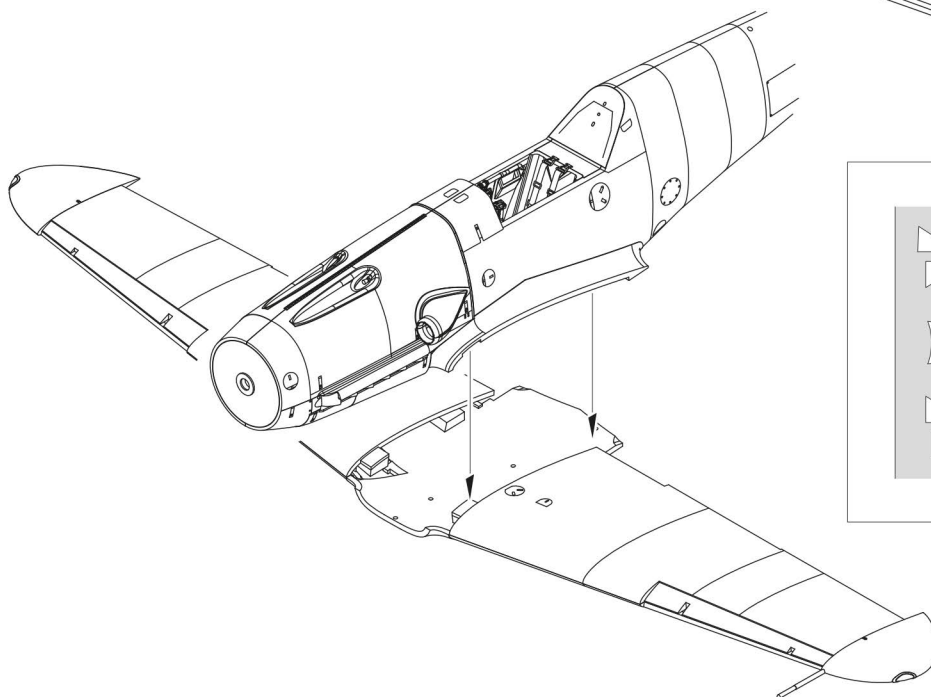

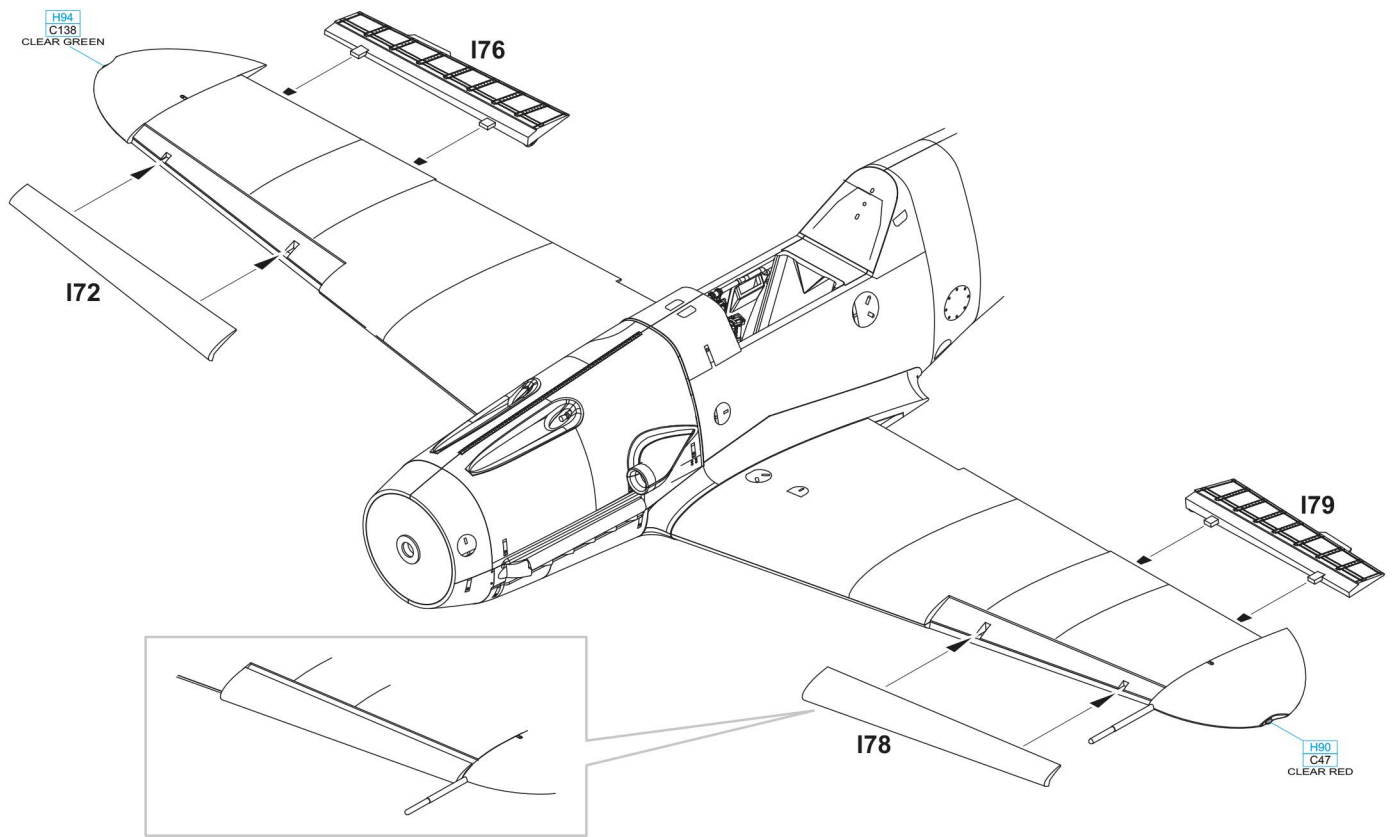

**FRONT VIEW**

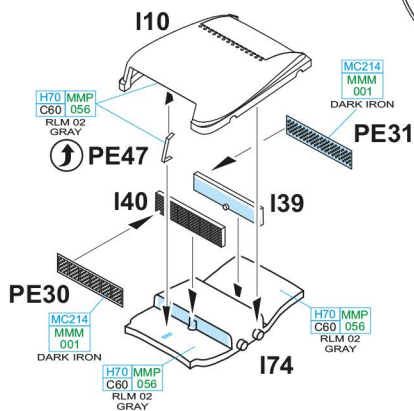
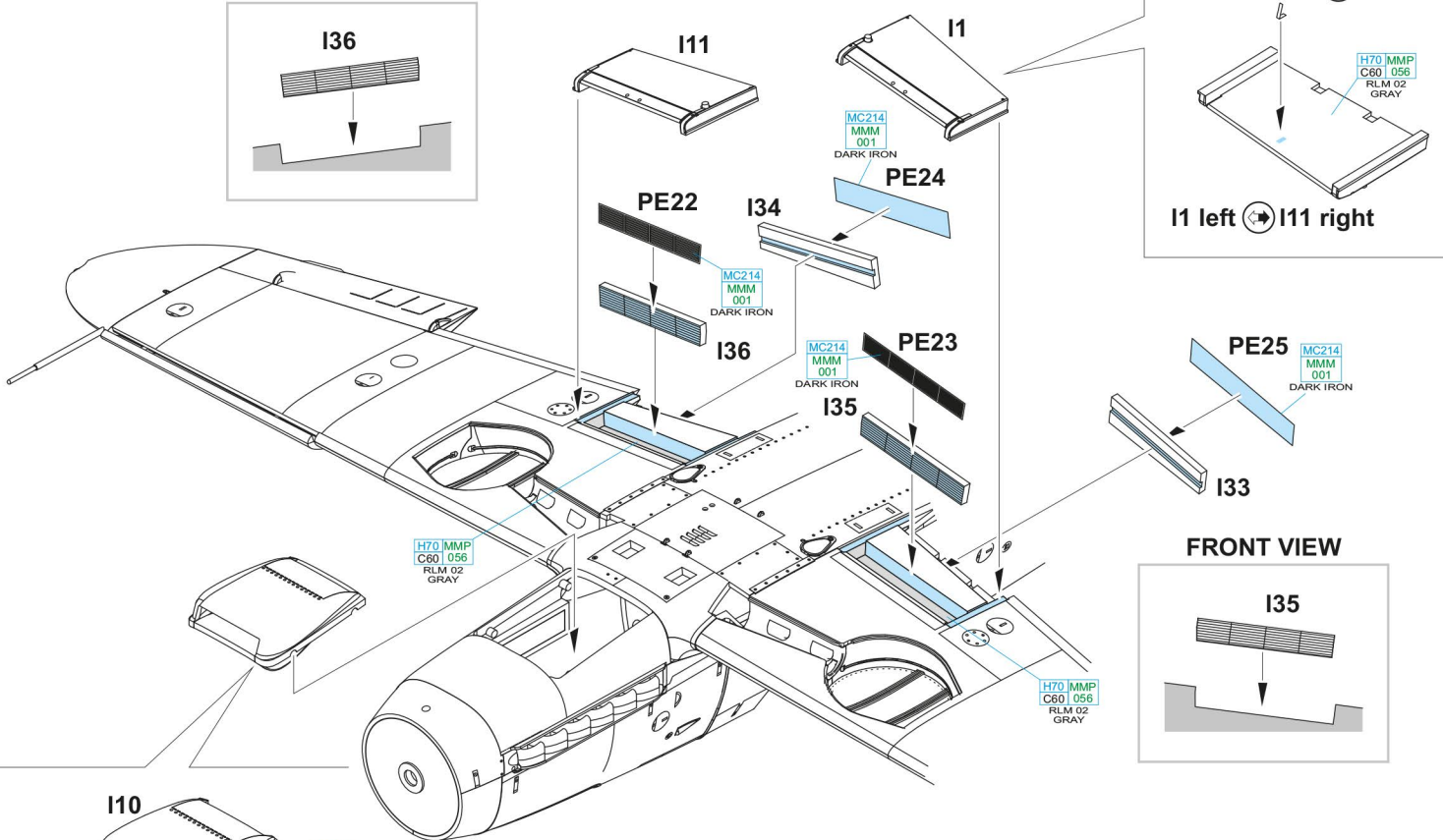
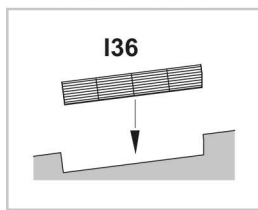

**CORRECT POSITION OF RADIATOR FLAPS**

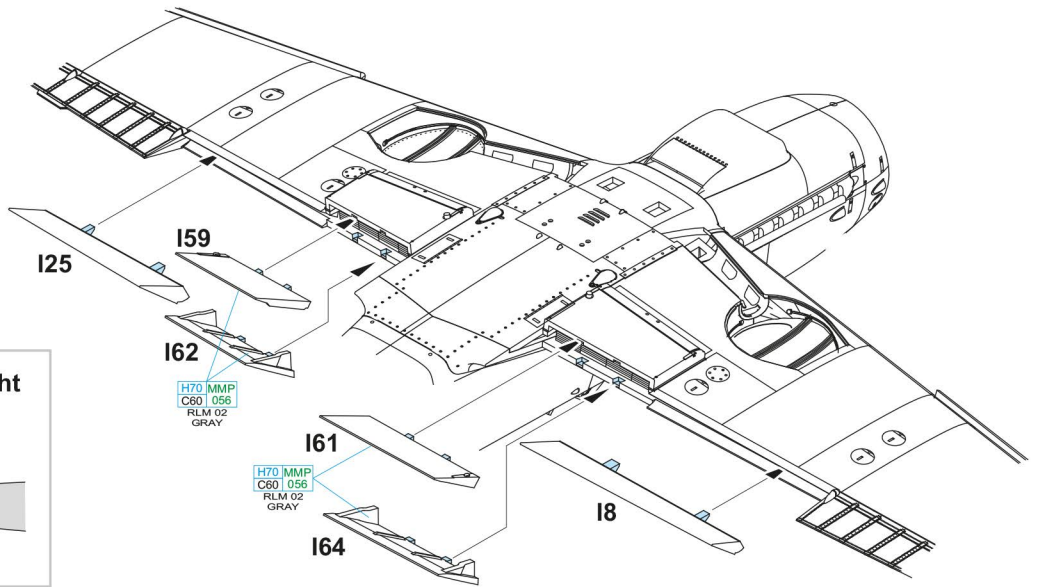
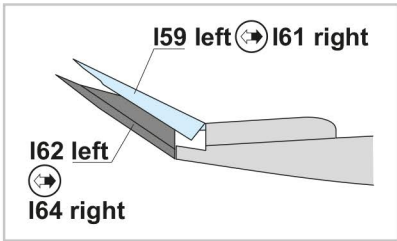

**eduard BRASSIN**

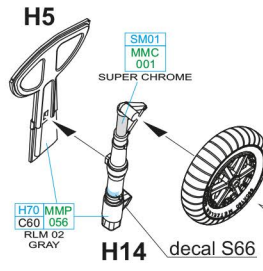
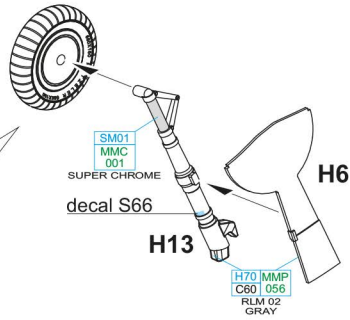
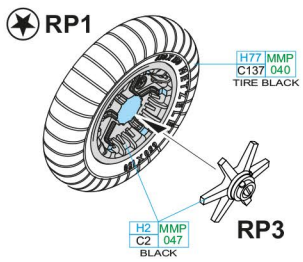

**eduard BRASSIN**

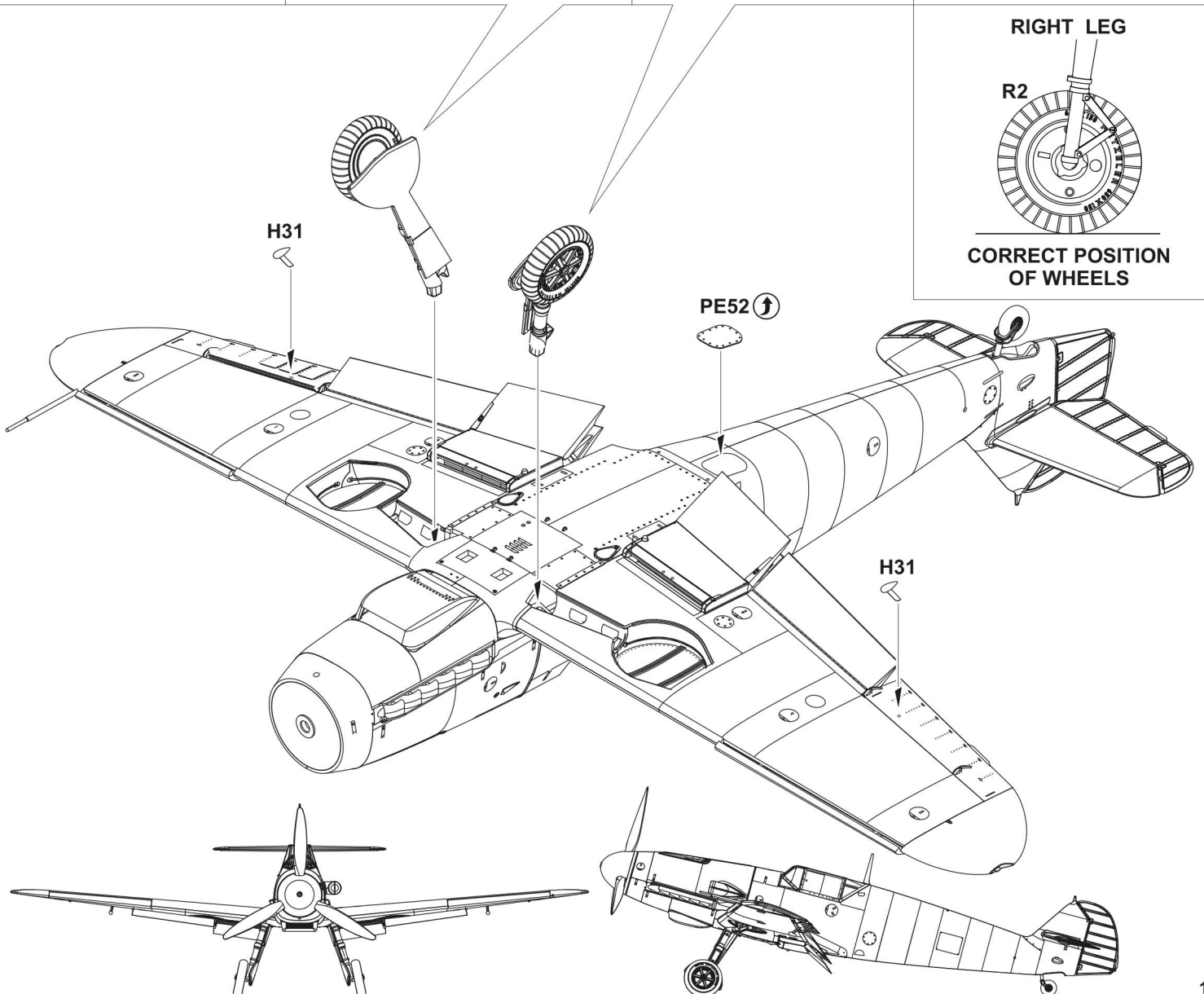
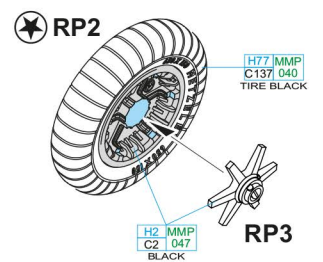

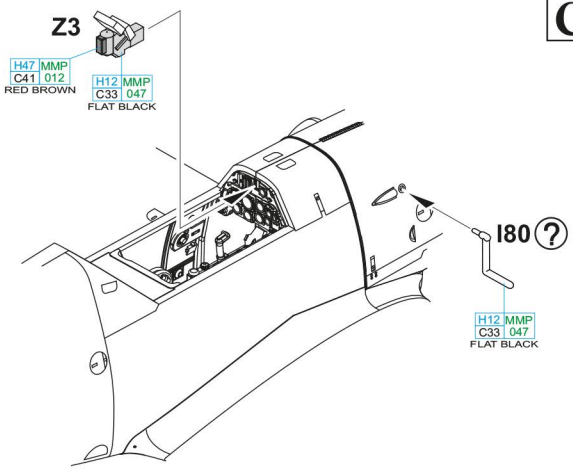

**C D**

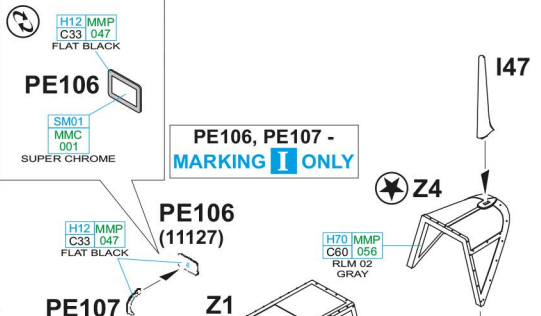
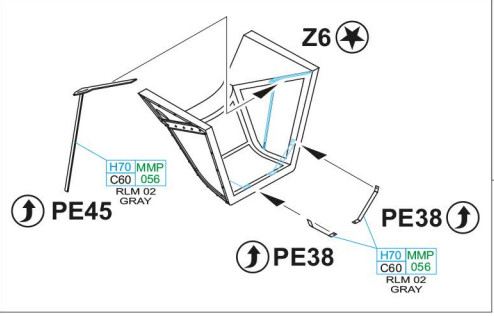
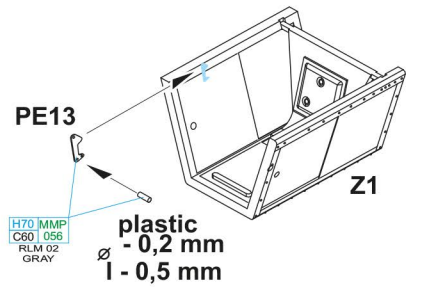
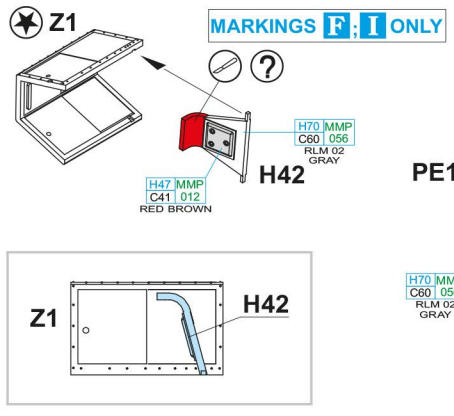

**Z5 - MARKINGS F; K ONLY**

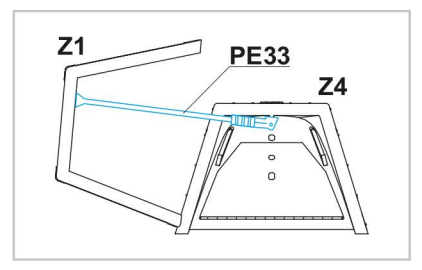
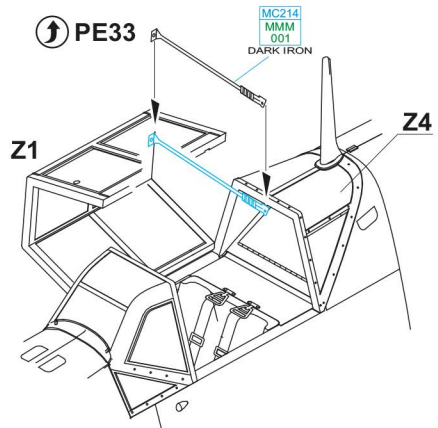
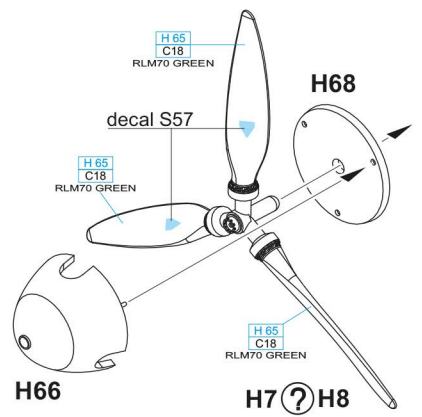
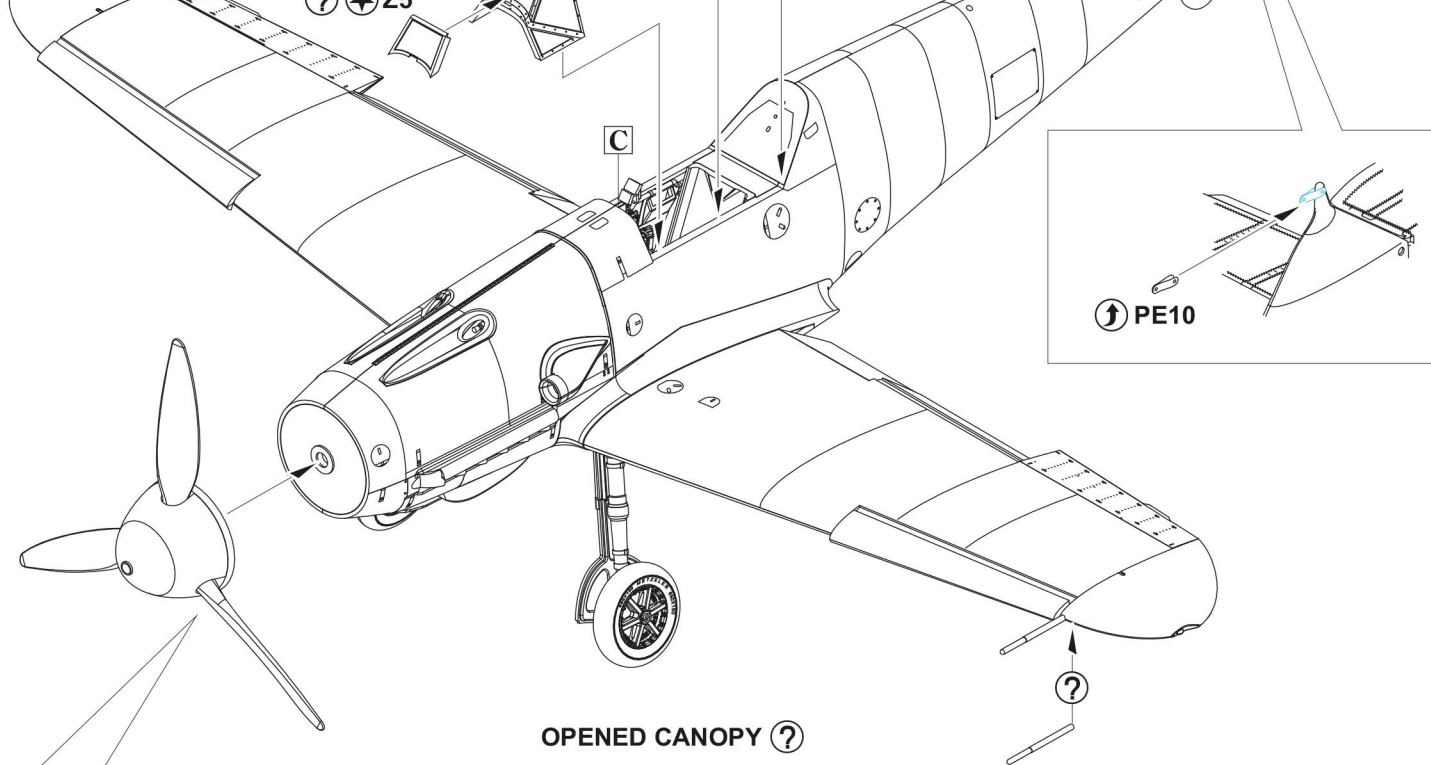

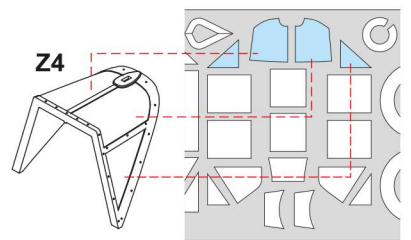
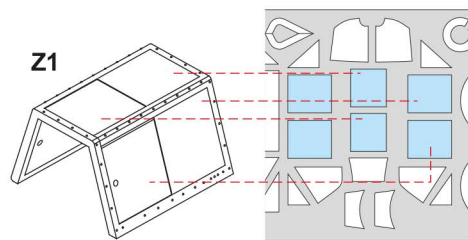
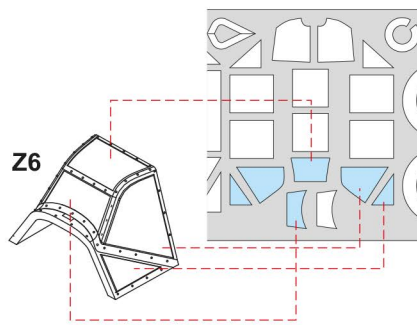
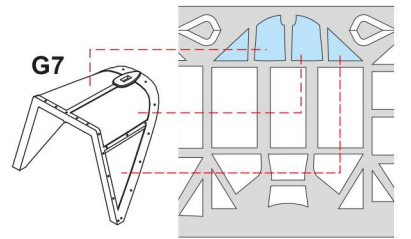
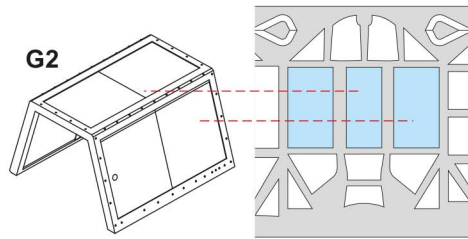
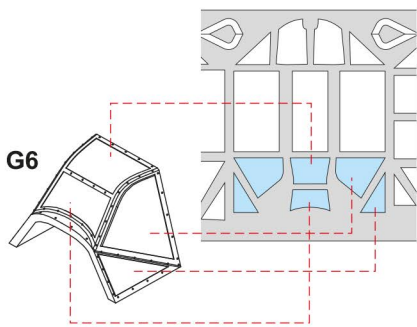
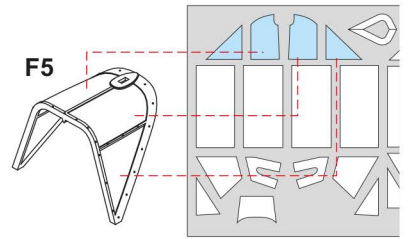
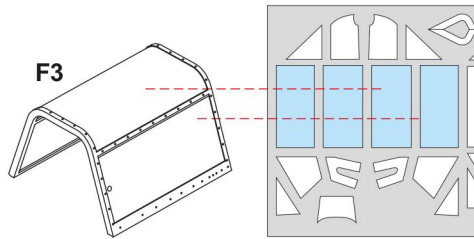
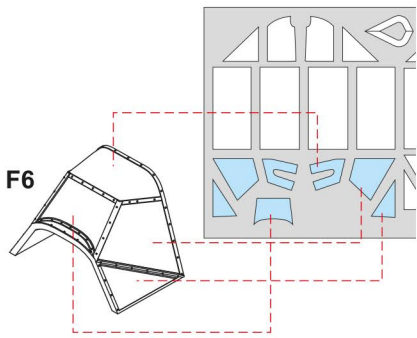
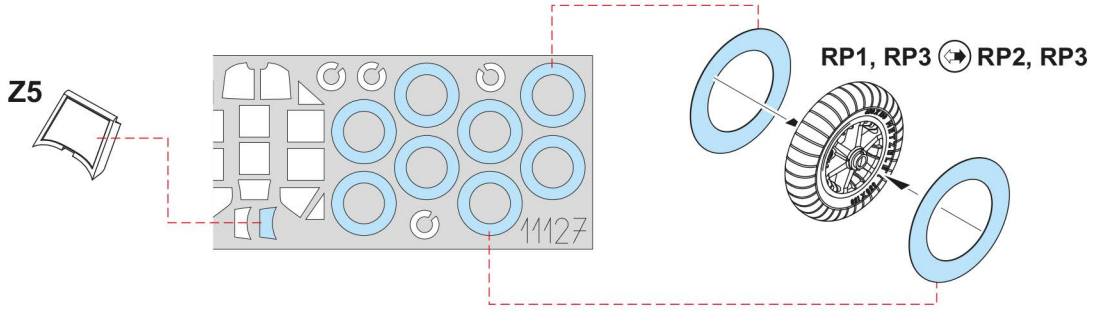
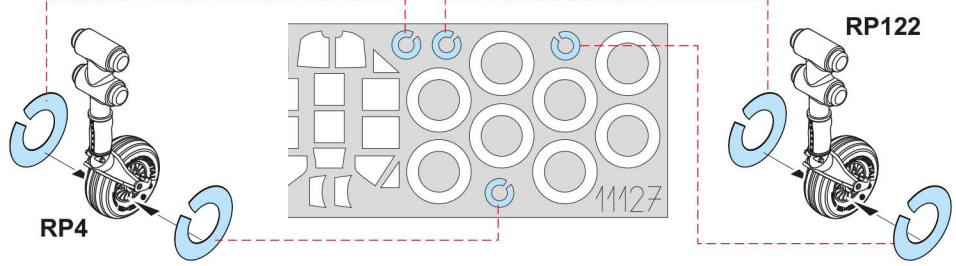
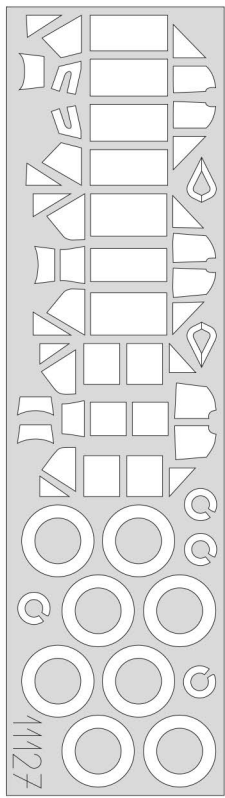

# A Bf 109E-4/B, W. Nr. 3605, flown by Ofw. Reinhold Schmetzer, 8./JG 77, Balti, Soviet Union (nowadays Republic of Moldova), July 1941

After the battle for Crete in the beginning of June 1941 III. /JG 77 was transferred to Vienna for a short rest and here its equipment was supplemented by Messerschmitts Bf 109F. Regardless the majority of the equipment was represented by series E aircraft. In the middle of the month the unit was relocated to the Romanian territory from where, on June 22nd, 1941, it commenced its participation in the operation Barbarossa. Reinhold Schmetzer flying "black 5" achieved his first kill (5th in his fighter pilot career) during the USSR campaign the very first day when he shot down a Soviet I-16. Having been hit in the engine of his "black 5" on July 20th, 1941, he force-landed at Balti airport. On May 7th, 1944, already in the JG 4 ranks, Lt. Schmetzer was killed in the air combat over the central Italy. His final score in World War II was 31 victories. The upper and side surfaces of this aircraft were over-sprayed in almost solid coat of RLM 71, aircraft marking in the form of black number 5 outlined in white is complementing the III. Gruppe JG 77 marking on the airplane's nose, the lower surfaces and the tail sport the yellow marking of the aircraft deployed to the Eastern front. The rudder carries the white bars indicating the aerial kills.

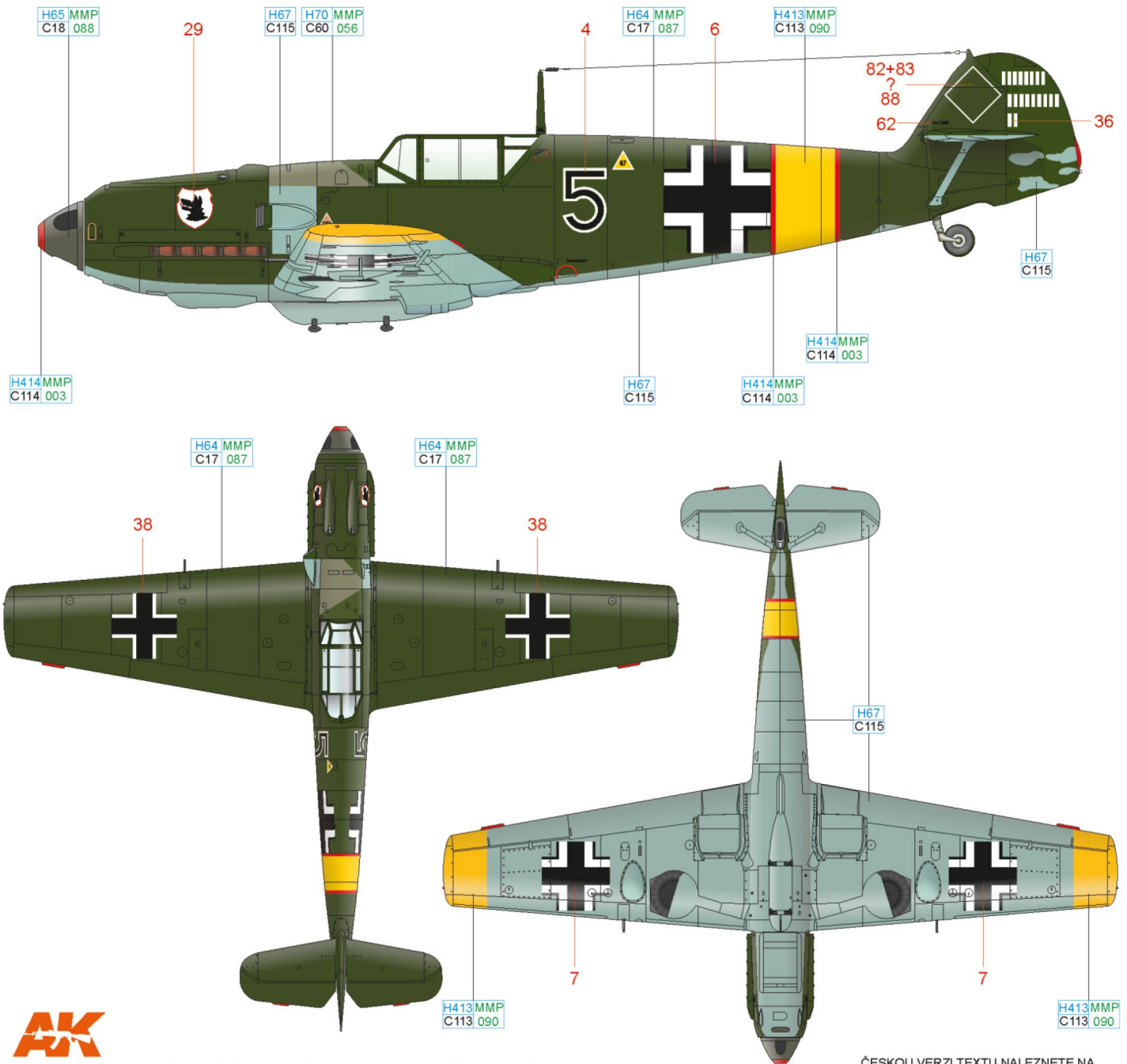

Special thanks to AK Interactive to cooperation on this project

ČESKOU VERZI TEXTU NALEZNETE NA [www.eduard.cz](http://www.eduard.cz)

POD KATALOGOVÝM ČÍSLEM 11127

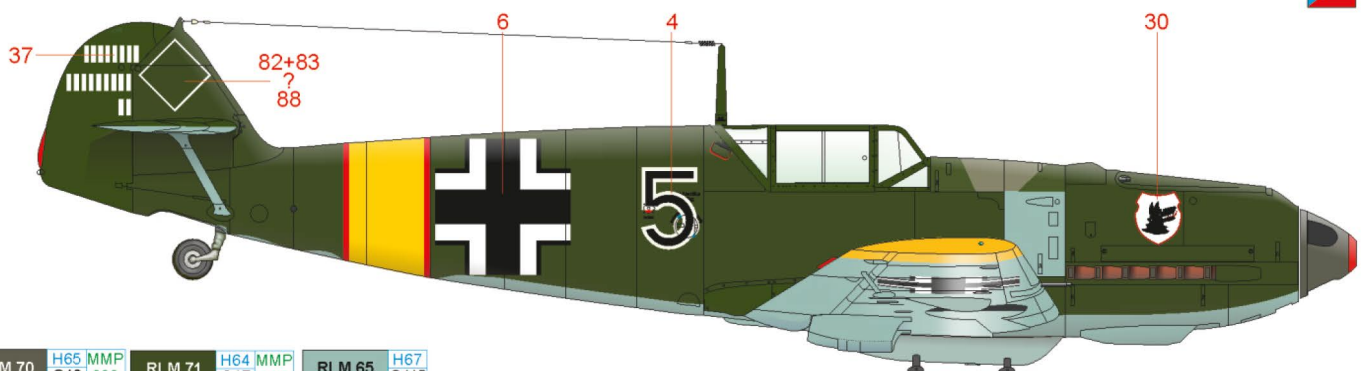

RLM 70	H65 MMP C18 088	RLM 71	H64 MMP C17 087	RLM 65	H67 C115
RLM 23	H414 MMP C114 003	RLM 04	H413 MMP C113 090	RLM 02	H70 MMP C60 056

# B Bf 109E-4/B, W. Nr. 2060, flown by Lt. Hans Guse, 2.(J)/LG 2, Tudora, Soviet Union (today's Republic of Moldova), July 1941

Same as JG 77, after the Greek campaign the Lehrgeschwader 2 was withdrawn from the combat to rest and re-equip which was to take place in Belgrade. The relocation to the Romanian territory followed in the middle of July where the Messerschmitt Bf 109E (some in the fighter-bomber configuration) equipped LG 2 was on alert to be deployed against the Soviet Union. Its operation Barbarossa participation started early morning of June 22nd. "Black 10" aircraft, which retained its camouflage from Greece and Crete campaigns and was equipped with a tropical filter, was shot down by Soviet I-16 on July 10th, 1941. The pilot is still listed as missing in action. The aircraft marking is complemented by I.(J)/LG 2 marking under the windshield and 2. (J)/LG 2 behind the fuselage cross.

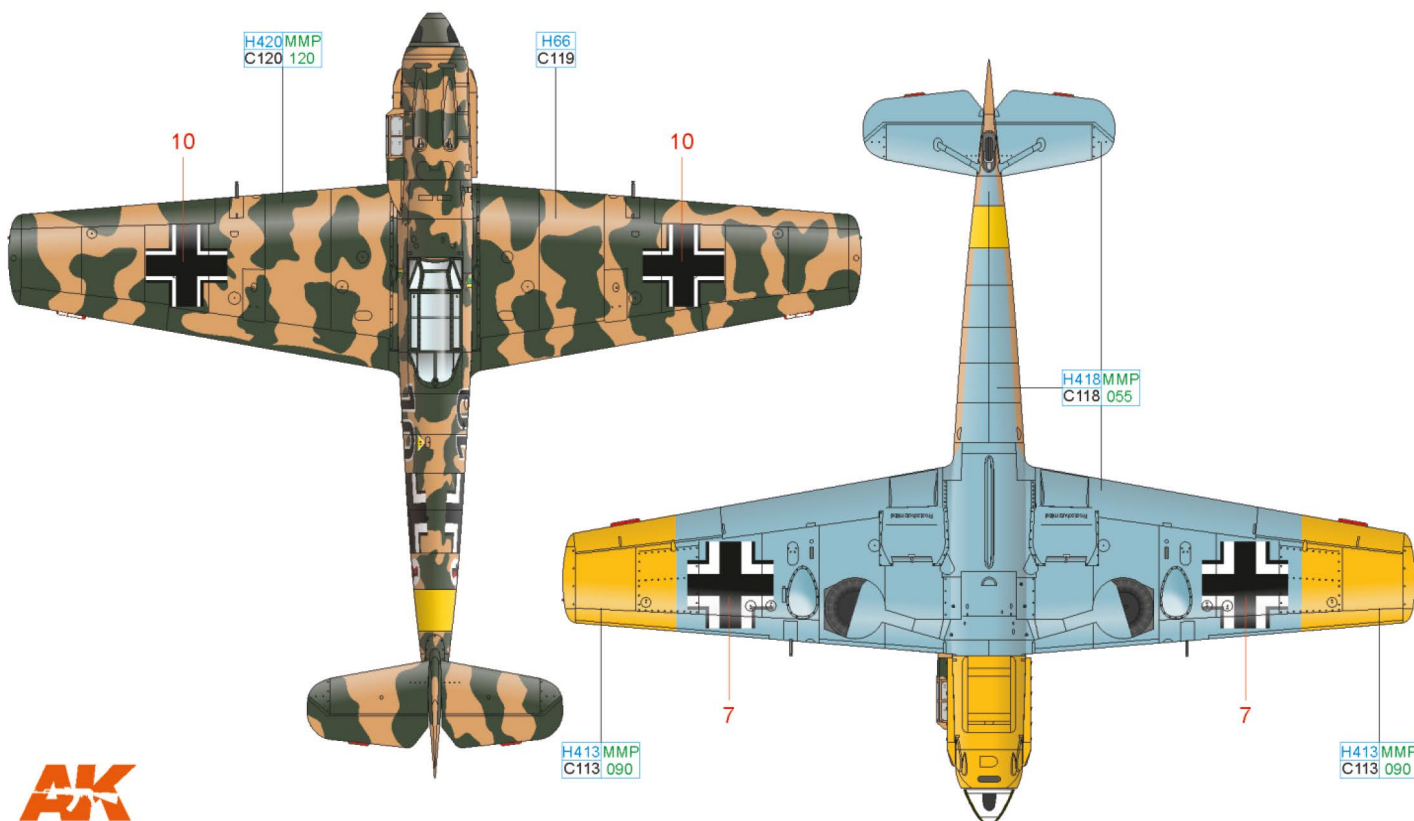
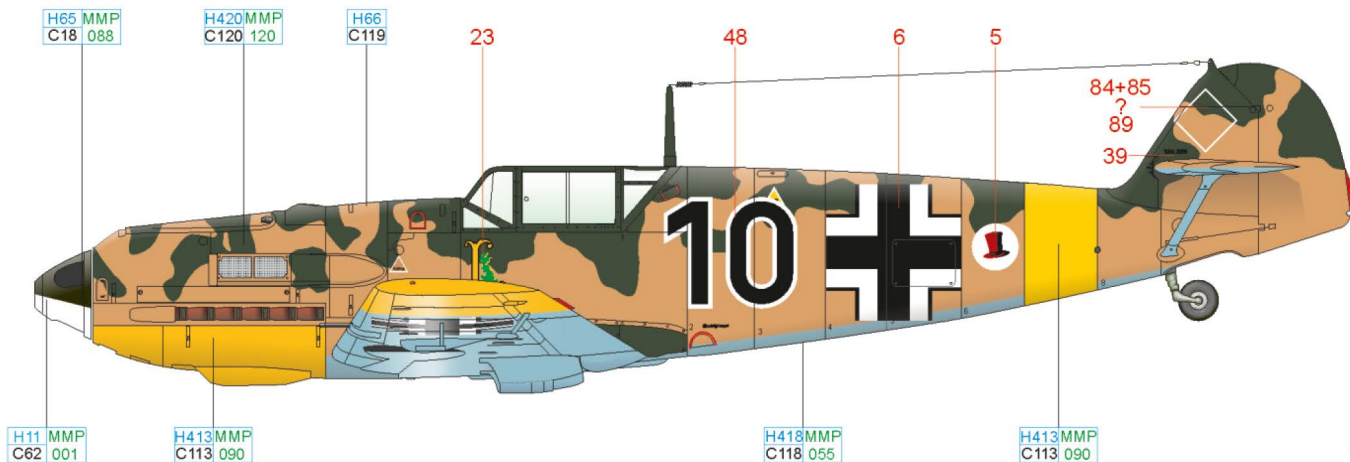

Special thanks to AK Interactive to cooperation on this project

ČESKOU VERZI TEXTU NALEZNETE NA [www.eduard.cz](http://www.eduard.cz) POD KATALOGOVÝM ČÍSLEM 11127

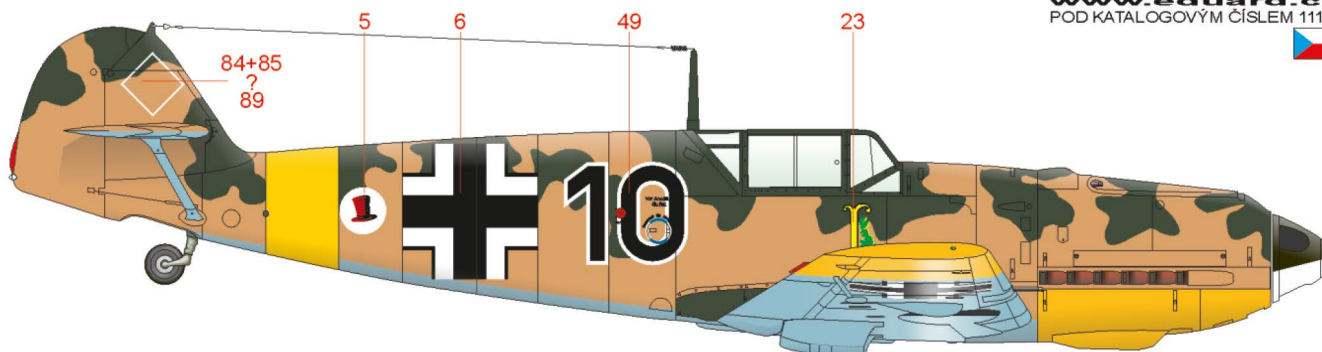

RLM 70	H65 MMP C18 088	RLM 04	H413MMP C113 090	RLM 79	H66 C119
WHITE	H11 MMP C62 001	RLM 78	H418MMP C118 055	RLM 80	H420MMP C120 120

# C Bf 109E-7, W. Nr. 1326, flown by Oblt. Erbo Graf von Kageneck, CO of 9./JG 27, Soltsy, Soviet Union, August 1941

After the Balkans campaign the III./JG 27 ground detachment was dispatched by train to the location of its future operations which was the airport in, at that time, East Prussia, located only several kilometers from the demarcation line established by Hitler and Stalin by which they divided Poland. The unit arrived at its destination on June 4th, 1941 and in couple of days was joined by the flying detachment of the unit. The main task of this Gruppe, equipped with Messerschmitts Bf 109E-4 and E-7, were to be the fighter-bomber attacks on the Soviet units. Oblt. von Kageneck, Commander of 9. Staffel JG 27, flew the aircraft marked with yellow 1 and camouflaged in RLM 71/02/65 until August 20th, 1941, when it was damaged during the emergency landing. On October 17th, III./JG 27 was transferred back to Germany for the rest and re-equipment, it's next deployment was the Mediterranean area of operation. During his deployment in the operation Barbarossa, Erbo Graf von Kageneck shot down 47 Soviet airplanes, on October 26th, 1941 he was awarded the Oak Leaves to the Knight's Cross. On December 24th, 1941, during the African campaign, he was shot down and succumbed to his wounds in the Naples hospital in less than 3 weeks. It's stated that his victor was the RAF Australian ace Clive Caldwell.

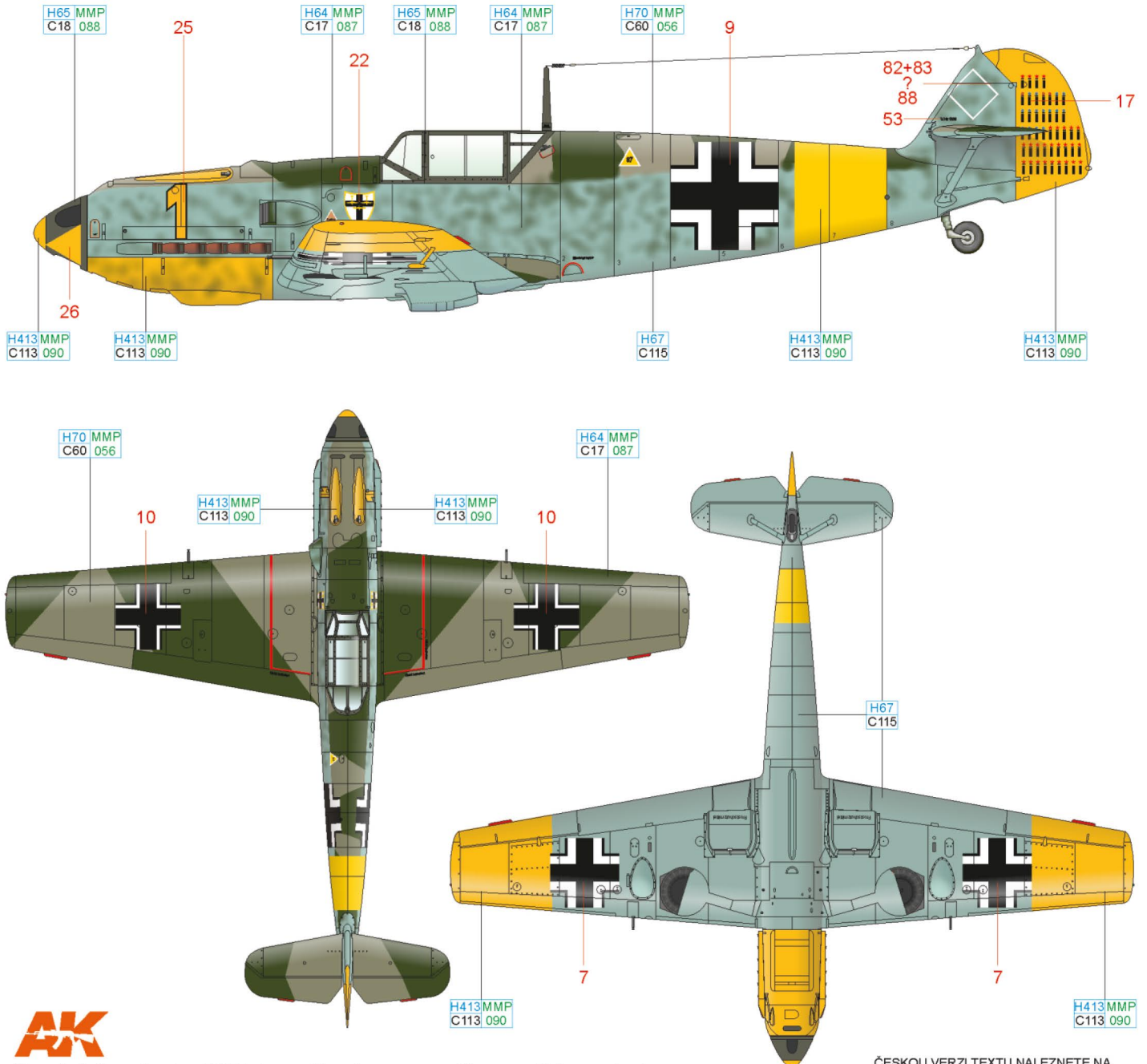

Special thanks to AK Interactive to cooperation on this project

ČESKOU VERZI TEXTU NALEZNETE NA [www.eduard.cz](http://www.eduard.cz) POD KATALOGOVÝM ČÍSLEM 11127

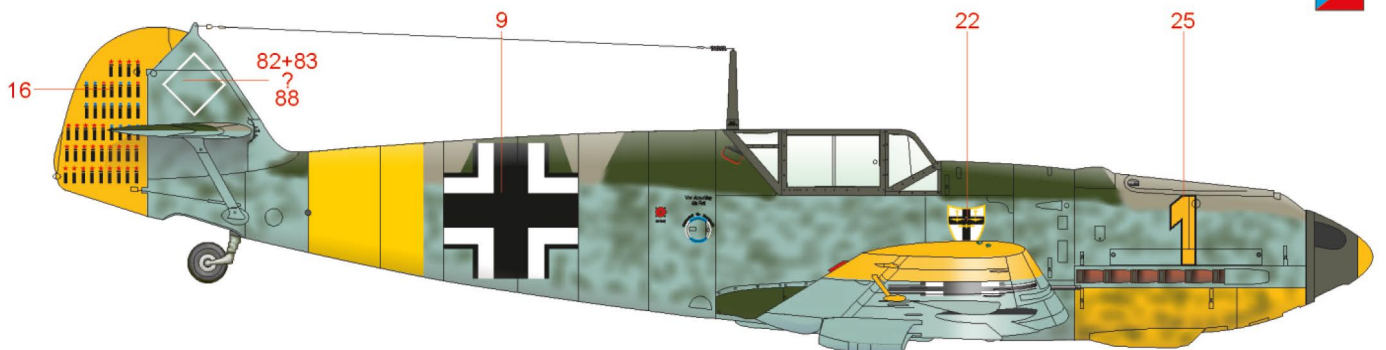

RLM 02	H70 MMP C60 056	RLM 70	H65 MMP C18 088
RLM 71	H64 MMP C17 087	RLM 04	H413 MMP C113 090
		RLM 65	H67 C115



# D Bf 109E-7, W. Nr. 6095, flown by Hptm. Herbert Ihlefeld, CO of I.(J)/LG 2, Iasi, Romania, July 1941

Herbert Ihlefeld, born on June 1st, 1914 in Pinnow, joined the army in 1933, in 1935, on his own request, he was transferred to the Luftwaffe, completed the pilot training and saw combat in the ranks of the Legion Condor in Spain, where he achieved seven confirmed aerial victories. After the return to Germany he was attached to LG 2 with which he participated in the Polish and French campaigns, during the Battle of Britain he was promoted to command I.(J)/LG 2. Leading this unit, he participated in the Balkans campaign and the attack on the Soviet Union. His aircraft, camouflaged in RLM 71/02/65 and marked by double chevron, carried the I.(J)/LG 2 marking under the windshield. The aircraft side surfaces were significantly darkened by RLM 71. The rudder sports the kill markings in the form of the white bars with national marking. Herbert Ihlefeld survived the World War II during which he claimed 130 aerial victories (including seven from Spain) and was awarded with the Knight's Cross with the Oak Leaves, Swords and Diamonds. He passed away on August 8th, 1995 in the town of Wennigsen, Lower Saxony.

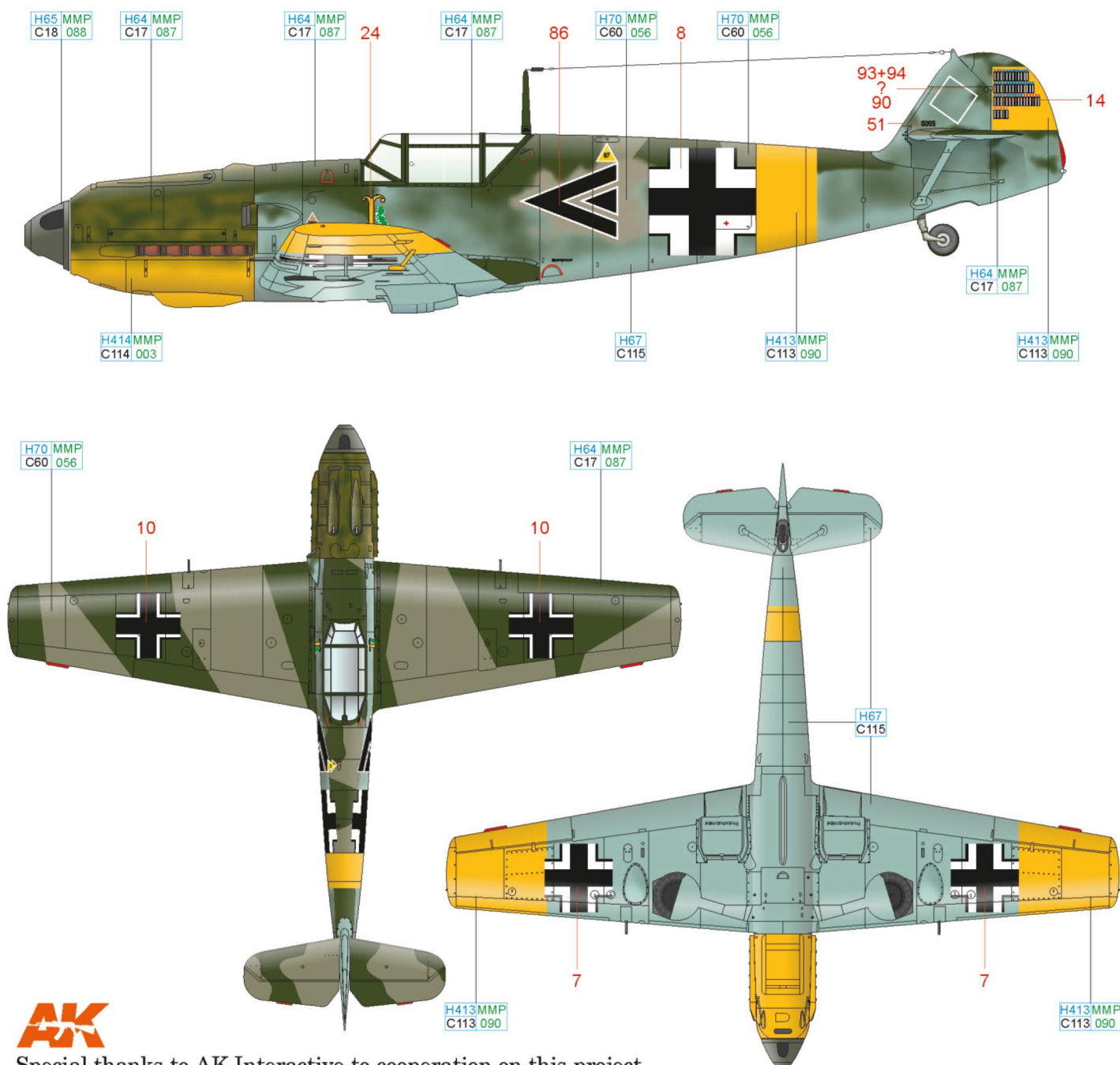

Special thanks to AK Interactive to cooperation on this project

ČESKOU VERZI TEXTU NALEZNETE NA  
[www.eduard.cz](http://www.eduard.cz)  
 POD KATALOGOVÝM ČÍSLEM 11127



RLM 02	H70 MMP C60 056	RLM 70	H65 MMP C18 088
RLM 71	H64 MMP C17 087	RLM 04	H413 MMP C113 090
		RLM 65	H67 C115

# E Bf 109E-7, 2./JG 51, Staraya Russa, Soviet Union, Winter 1941

After the deployment at the Channel area of operations, on May 25th, 1941 I./JG 51 was withdrawn to Krefeld to re-supply and re-equip. Here it received Bf 109F aircraft. 2. Staffel aircraft featured the ETC pylon to carry out the fighter-bomber missions. There were several E-version airplanes remaining on strength. Transfer further East followed the short rest. The new location was an aerodrome nearby the Polish village of Starawies, from where, in the early morning of June 22nd, 1941 the unit performed the first sortie over the territory of the Soviet Union as a part of the operation Barbarossa. During the winter time the Luftwaffe aircraft on the Eastern Front were painted on the upper and side surfaces in the white distemper paint to improve the camouflage. This measure applied to "black 4" as well where the white distemper was not only painted on the original top and side surfaces camouflage but partially covered the rudder yellow marking as well. The lower surfaces remained in RLM 65 color. The yellow markings indicated the Eastern Front deployment.

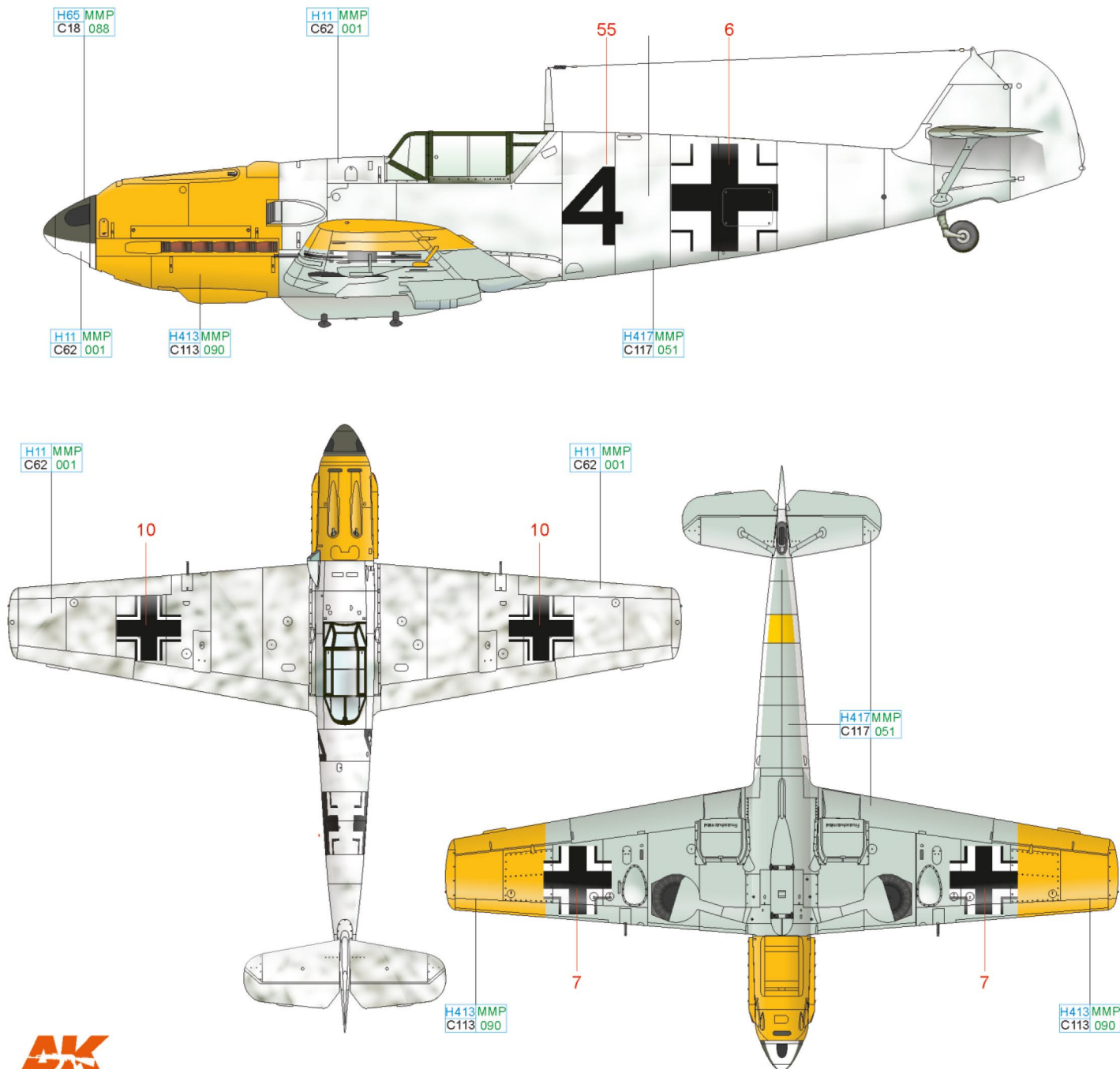

Special thanks to AK Interactive to cooperation on this project

ČESKOU VERZI TEXTU NALEZNETE NA  
[www.eduard.cz](http://www.eduard.cz)  
 POD KATALOGOVÝM ČÍSLEM 11127

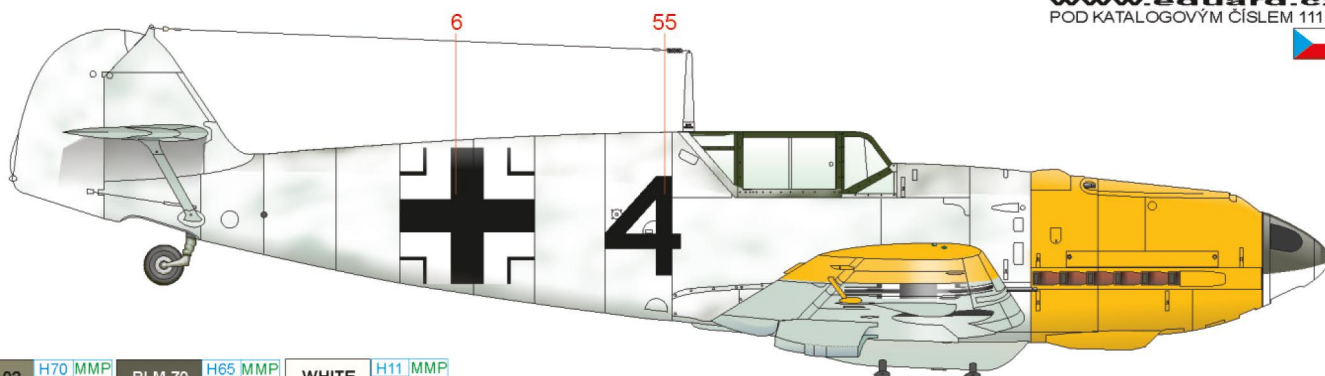

RLM 02	H70 MMP C60 056	RLM 70	H65 MMP C18 088	WHITE	H11 MMP C62 001
RLM 71	H64 MMP C17 087	RLM 04	H413 MMP C113 090	RLM 76	H417 MMP C117 051

# F Bf 109F-2, W. Nr. 5458, flown by Hptm. Hans von Hahn, CO of I./JG 3, Polonnoye, Soviet Union, July 1941

After the I./JG 3 was withdrawn from France on June 9th, 1941 it was dispatched to Breslau (today's Wrocław in Poland) to rest and replenish the losses. On June 18th the whole Gruppe continued further East, to Zamosc airport in, at that time, General Government, name for the Polish territory occupied by the German army. The unit's task after the attack on the Soviet Union was the air cover for the Heeresgruppe Süd during it's attack on Ukraine. I./JG 3 commander at that time was Hans von Hahn, who was awarded with the Knight's Cross on July 9th, 1941. Until the end of the World War II he shot down 31 enemy aircraft. Hans von Hahn airplane he flew in combat against the English airmen was camouflaged in RLM 71/02/65 supplemented by circles and irregular lines on the fuselage sides sprayed in RLM 71. The aircraft nose sported the I./JG 3 marking - legendary worm Tatzelwurm in green color, there was a pilot's personal marking under the windshield on the port side of the fuselage, Frankfurt shield, pilot's birthplace on the starboard. The rudder carried Hans von Hahns' kill markings in the form of black bars.

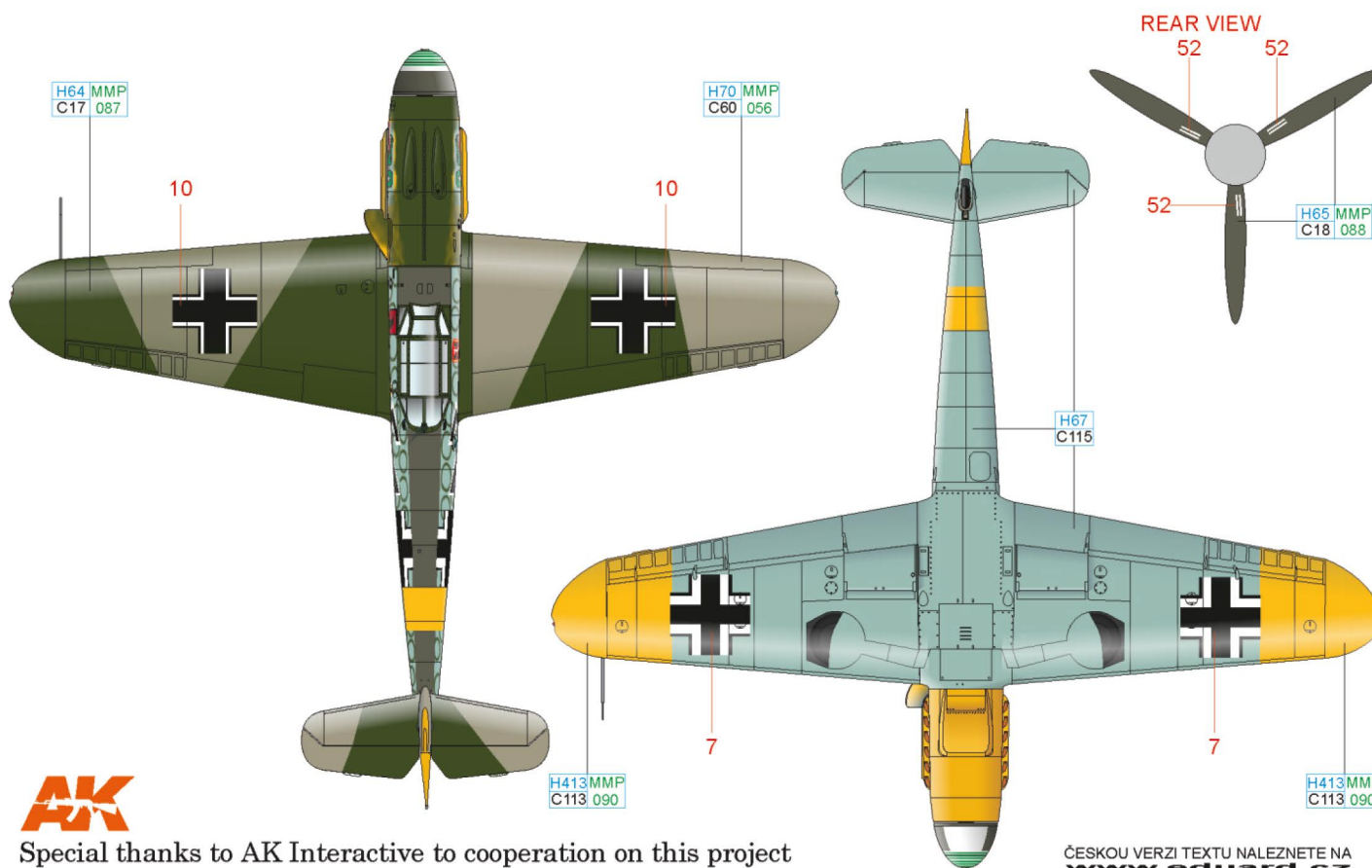
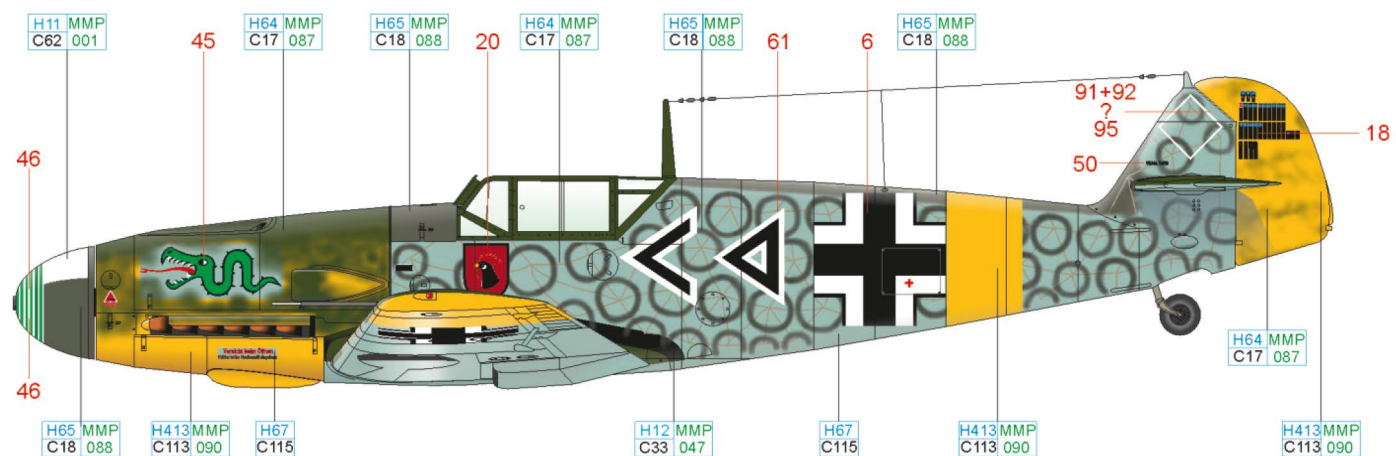

Special thanks to AK Interactive to cooperation on this project

ČESKOU VERZI TEXTU NALEZNETE NA [www.eduard.cz](http://www.eduard.cz) POD KATALOGOVÝM ČÍSLEM 11127

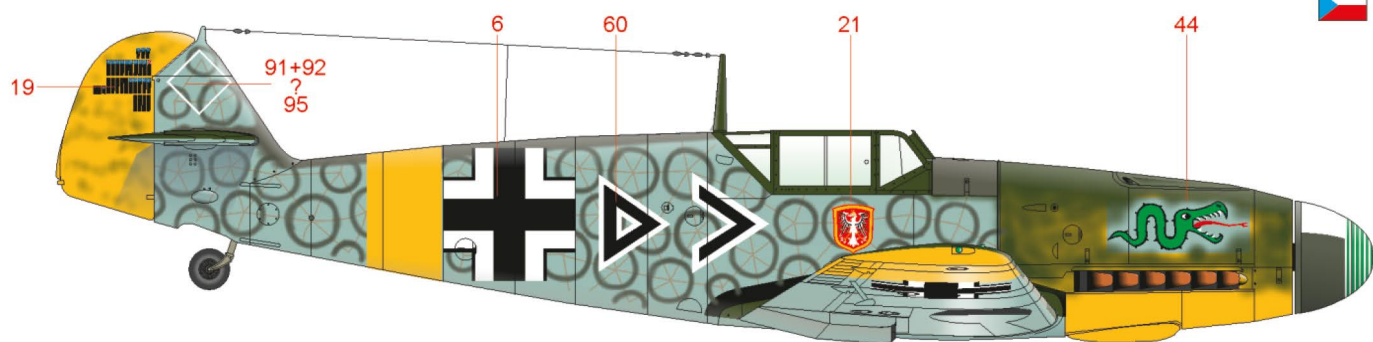

RLM 02	H70 MMP C60 056	RLM 70	H65 MMP C18 088	BLACK	H12 MMP C33 047
RLM 71	H64 MMP C17 087	RLM 04	H413 MMP C113 090	WHITE	H11 MMP C62 001
					RLM 65 H67 C115

# G Bf 109F-2, flown by Lt. Gerhard Barkhorn, 6./JG 52, Sobolevo, Germany (Russia now), June 1941

Same as III./JG 53 the II./JG 52 unit was withdrawn from the Channel area deployment in the beginning of June 1941 and without any rest re-located to Sobolevo and Suvalki airports in, at that time, East Prussia, nearby the demarcation line between the Soviet Union and German Reich. It was to take off for sorties providing the air cover for the left wing of the Heeresgruppe Mitte during the operation Barbarossa. On June 22nd, 1941, the attack on the Soviet Union was launched and II./JG 52 task was to destroy the Soviet aviation located at the nearby airports. On July 2nd, 1941 Gerhard Barkhorn shot down his first opponent in the form of the Soviet twin-engine bomber DB-3. Until the end of the hostilities he added another 300 kills, all achieved on the Eastern Front. On March 2nd, 1944 he was decorated with the Knight's Cross with the Oak Leaves and Swords. He survived the World War II and in 1956 he joined the reborn Luftwaffe, he commanded JaBoG 31 "Boelcke" and achieved the rank of General Lieutenant. He retired in 1983. On January 8th, 1983 he succumbed to severe wounds suffered in the car crash during which his wife Christl died as well. Yellow 7 flown by Lt. Barkhorn at the beginning of the operation Barbarossa was camouflaged in, at that time, standard Luftwaffe colors, RLM 02/71/65. The markings of the aircraft deployed to the Eastern Front consisted of yellow painted wing tips lower surfaces and rather wide yellow band in front of the tail surfaces typical for JG 52 complemented by JG 52 insignia under the windshield, 6. Staffel marking is painted under the canopy.

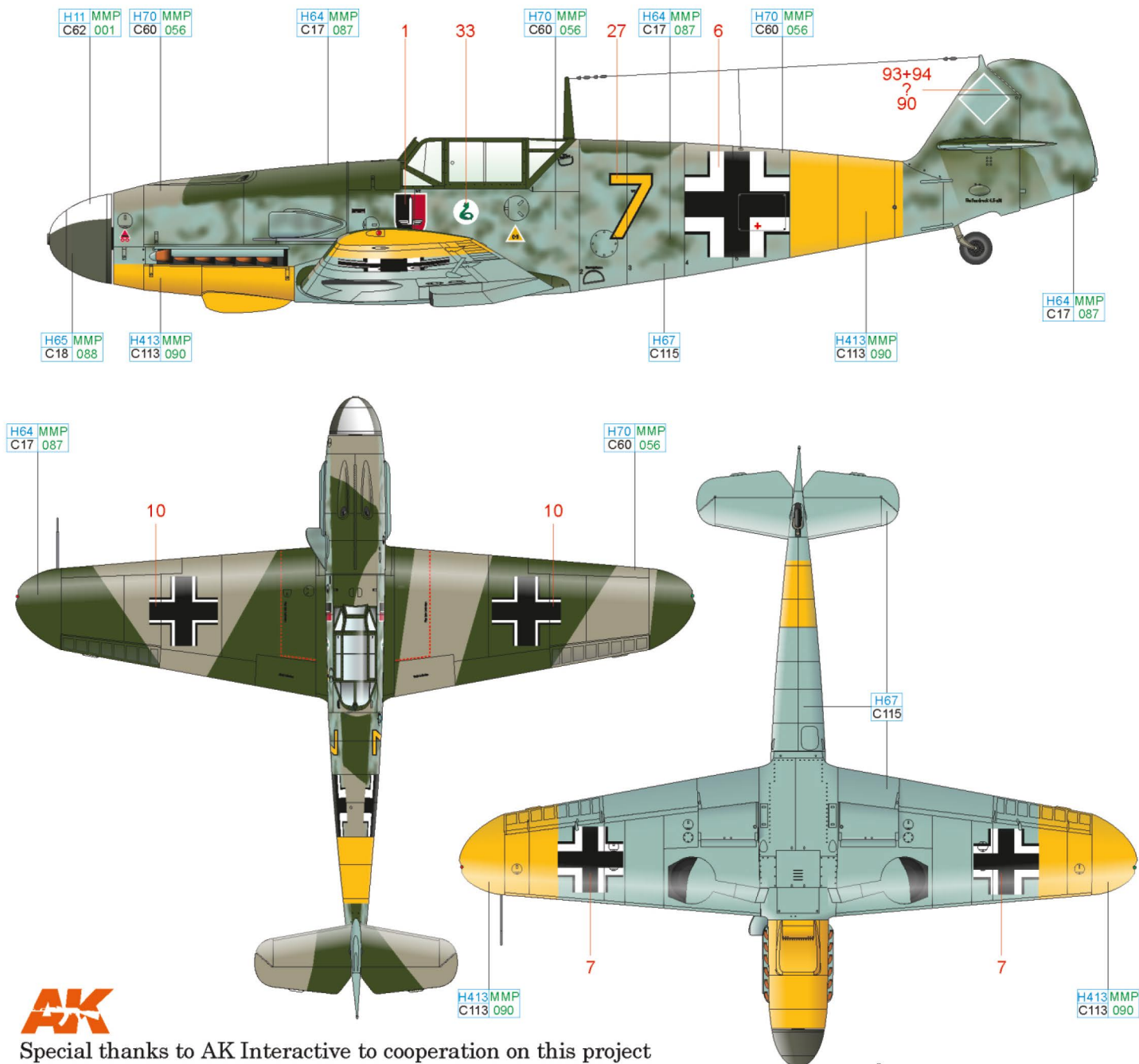

Special thanks to AK Interactive to cooperation on this project

ČESKOU VERZI TEXTU NALEZNETE NA [www.eduard.cz](http://www.eduard.cz) POD KATALOGOVÝM ČÍSLEM 11127



RLM 02	H70 MMP C60 056	RLM 70	H65 MMP C18 088	RLM 65	H67 C115
RLM 71	H64 MMP C17 087	RLM 04	H413 MMP C113 090	WHITE	H11 MMP C62 001



# Bf 109F-2, flown by Oblt. Hans Phillip, CO of 4./JG 54, Ovsishtshi, Soviet Union, August 1941

Hans "Fips" Phillip, the ace with 206 kills to his credit, achieved during 500 sorties, was born on March 17th, 1917 in Meissen. He enlisted in the Luftwaffe in 1936. At the beginning of the World War II he served with I./JG 76 which was re-designated II./JG 54 in June 1940. In the ranks of this unit he participated in the combats over the Britain, the Balkans and the operation Barbarossa. In April 1943 he was promoted to command JG 1 where, on October 8th, 1943, he was shot down and perished during the unsuccessful attempt to save himself on the parachute. For his combat successes he was decorated with the Knight's Cross with the Oak Leaves and Swords. The Messerschmitts Bf 109F-2 received by II./JG 54 in May 1941, were factory painted in RLM 02/71/65 colors, at the unit level the addition camouflage was sprayed on the side surfaces, typical for this Gruppe Emils since the beginning of 1941. Yellow painted wing tips lower surfaces and the rear fuselage band indicate the Eastern Front deployment.

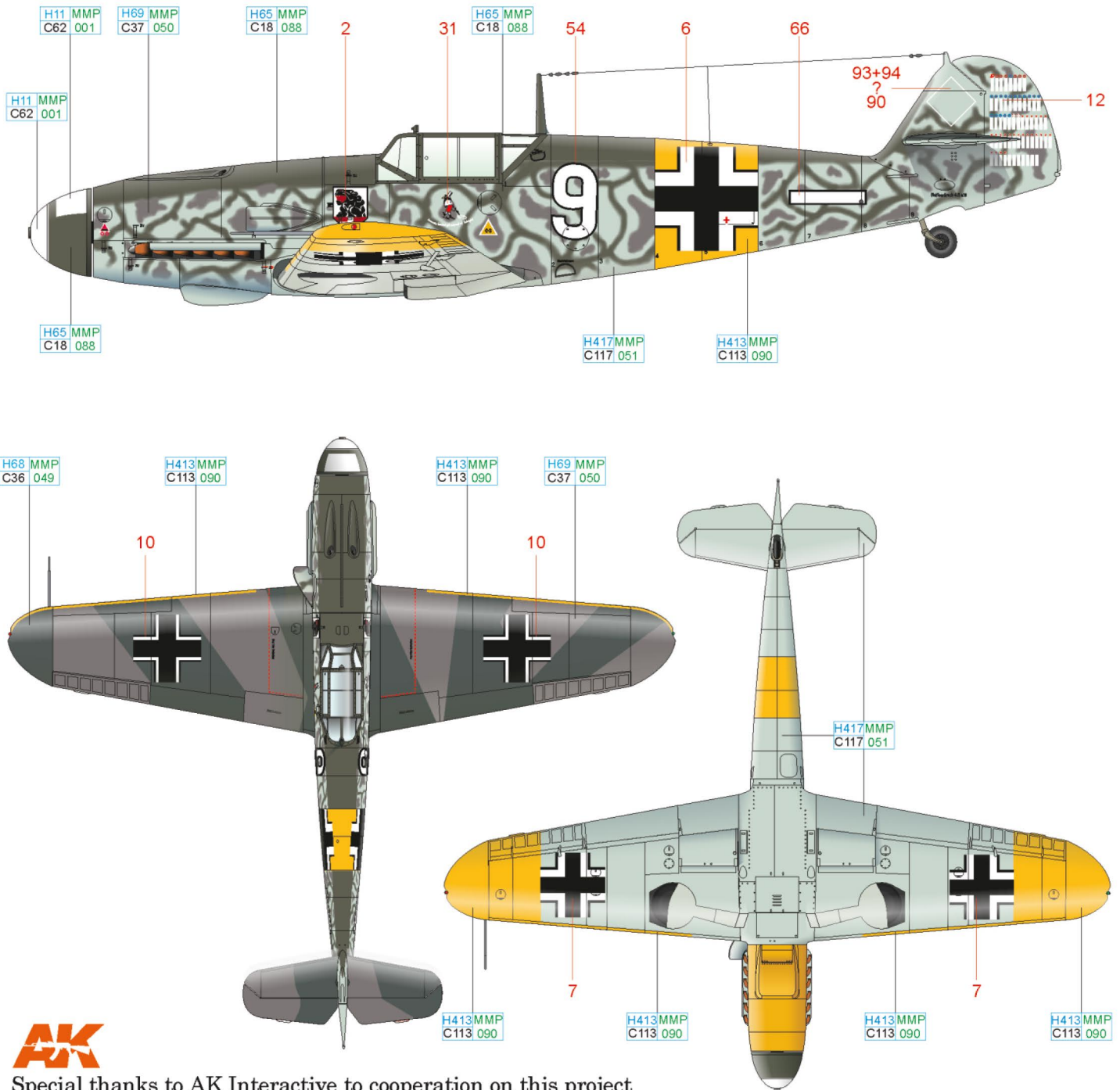

Special thanks to AK Interactive to cooperation on this project

ČESKOU VERZI TEXTU NALEZNETE NA [www.eduard.cz](http://www.eduard.cz) POD KATALOGOVÝM ČÍSLEM 11127

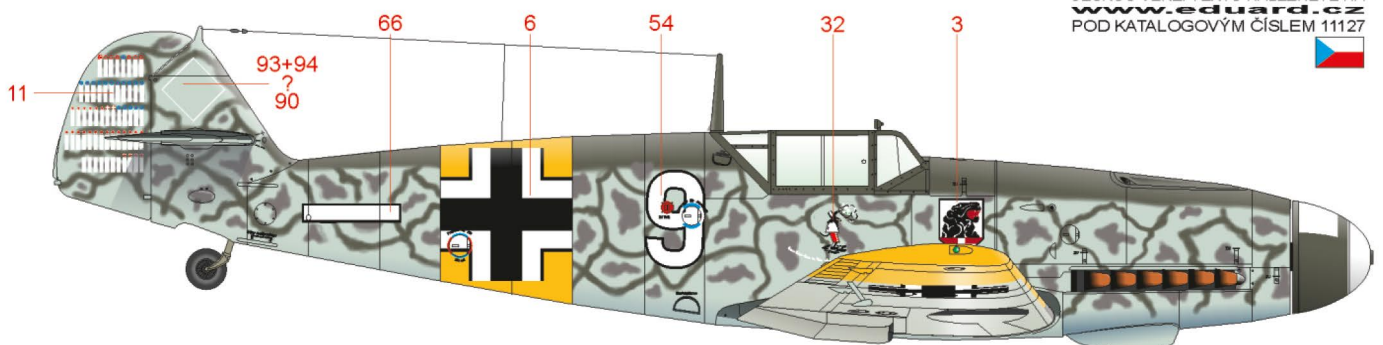

RLM 74	H68 MMP C36 049	RLM 70	H65 MMP C18 088	RLM 76	H417MMP C117 051
RLM 75	H69 MMP C37 050	RLM 04	H413MMP C113 090	WHITE	H11 MMP C62 001

# J Bf 109F-2, W. Nr. 8235, flown by Hptm. Werner Pichon Kalau vom Hofe, Stab JG 54, Trakehnen, Germany (today's Yasnaya Polyana, Russia now), June 1941

After the Balkans campaign the whole JG 54 was re-located back to Germany where it was re-equipped with more modern Messerschmitt Bf 109Fs and on June 15th, 1941, dispatched to Trakehnen airport from which it was to operate during the operation Barbarossa. Its task was to provide the air cover for the Heeresgruppe Süd during the attack in the Leningrad (today's St. Petersburg) direction. The Operation Barbarossa (Unternehmen Barbarossa) was a codename for the attack on the Soviet Union, preparation of which was ordered by Hitler himself shortly after the capitulation of France and was named after a Roman King and Emperor who ruled in 12th Century. During the operation Barbarossa, Werner Pichon Kalau vom Hofe held the position of the squadron headquarters technical officer at JG 54 therefore the fuselage of his aircraft carried the marking typical for a headquarters officer. The airplane was camouflaged on the upper surfaces in brown and green paints.

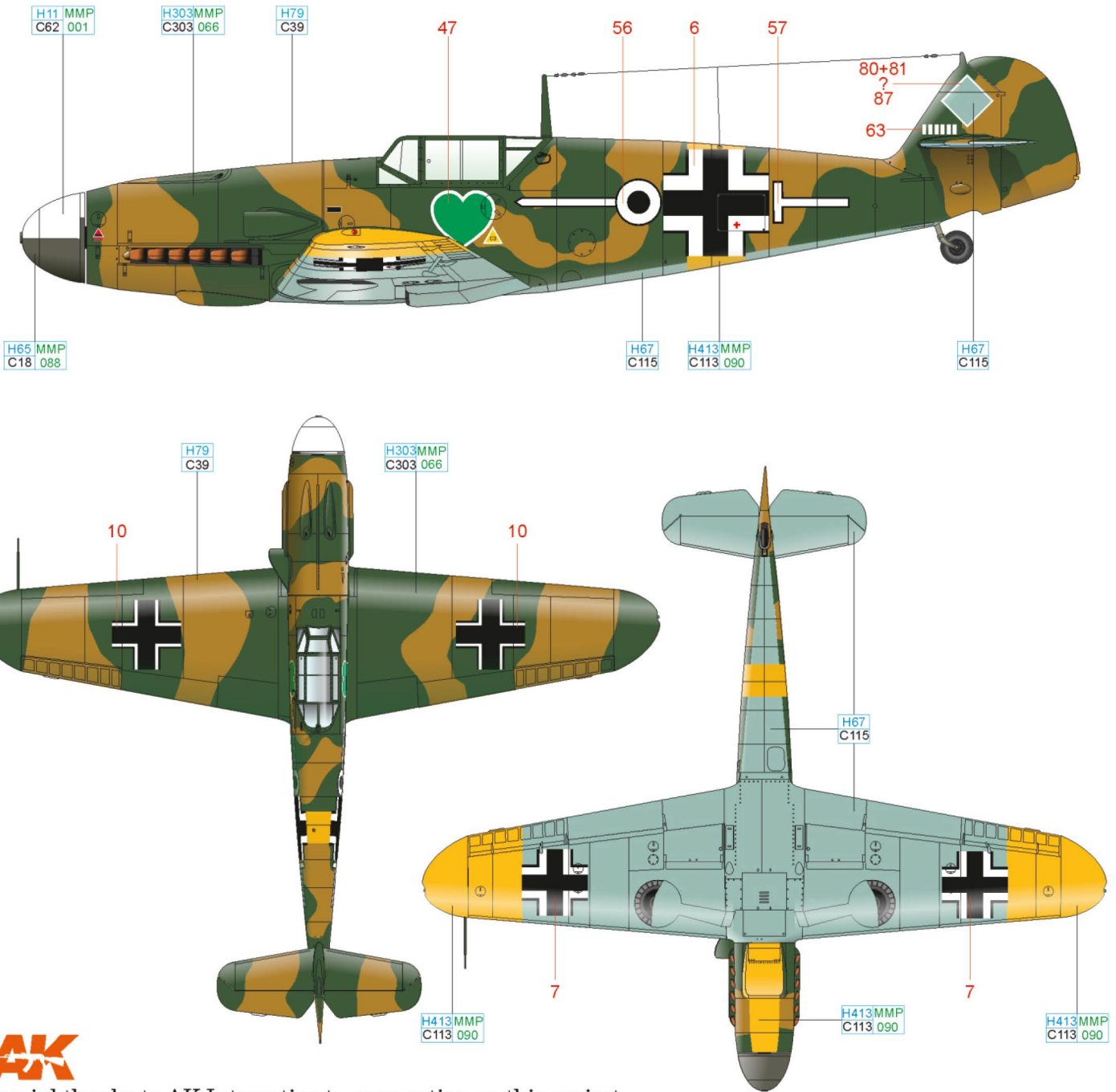

Special thanks to AK Interactive to cooperation on this project

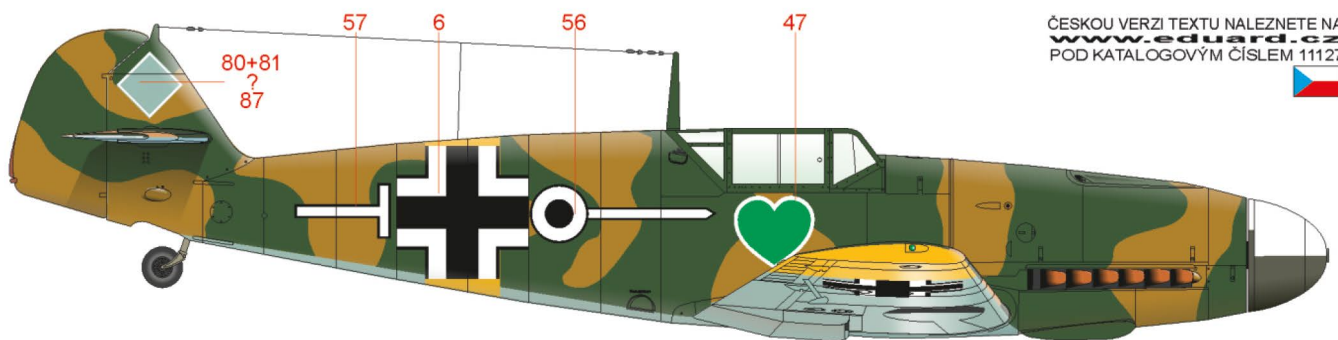

ČESKOU VERZI TEXTU NALEZNETE NA [www.eduard.cz](http://www.eduard.cz) POD KATALOGOVÝM ČÍSLEM 11127



RLM 70	H65 MMP C18 088	GREEN	H303MMP C303 066	BROWN	H79 C39
WHITE	H11 MMP C62 001	RLM 04	H413MMP C113 090	RLM 65	H67 C115

# K Bf 109F-2, W. Nr. 9704, flown by Maj. Günther Lützow, CO of JG 51, Yukhnov, Soviet Union, October 1941

After withdrawal from the Western European battlefield, short rest in Düsseldorf and re-equipment with the more modern Messerschmitt Bf 109F-2 on June 13th, 1941, JG 51 transferred to the Siedlce airport in the occupied Poland. Commanded by Werner Mölders, JG 51 task was to provide air cover for the Heeresgruppe Mitte during its advance in Belarus and Moscow direction. Having achieved his 100th kill Mölders was grounded and made the Inspector of the Fighters. Maj. Beckh took his place, until then he had lead IV./JG 51. On September 16th, 1941, Major Beckh was wounded and during his recovery until November 8th was substituted by the JG 3 commander Maj. Lützow. Between October 6th and 24th Günther Lützow achieved 25 kills, on October 11th he was decorated with the Knight's Cross with the Oak Leaves and Swords for his combat successes. Until the end of war he shot down 110 enemy aircraft. He was killed in the cockpit of his Me 262 during the combat with 356th FG Thunderbolts. From the beginning of October, while commanding JG 3 and JG 51 Günther Lützow flew this aircraft. Camouflage was painted in RLM 74/75/76 colors supplemented with yellow markings indicating the aircraft from the Eastern Front and JG 51 insignia was painted on the airplane's nose. The mechanics painted the air victories markings in the form of black bars on yellow painted rudder.

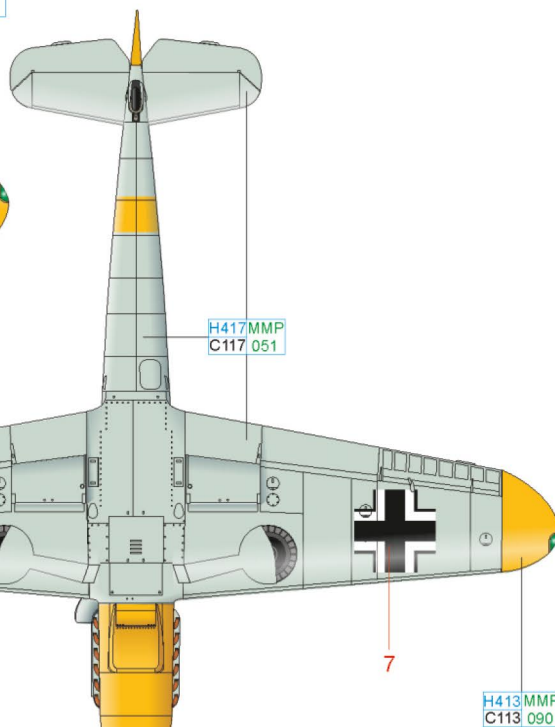
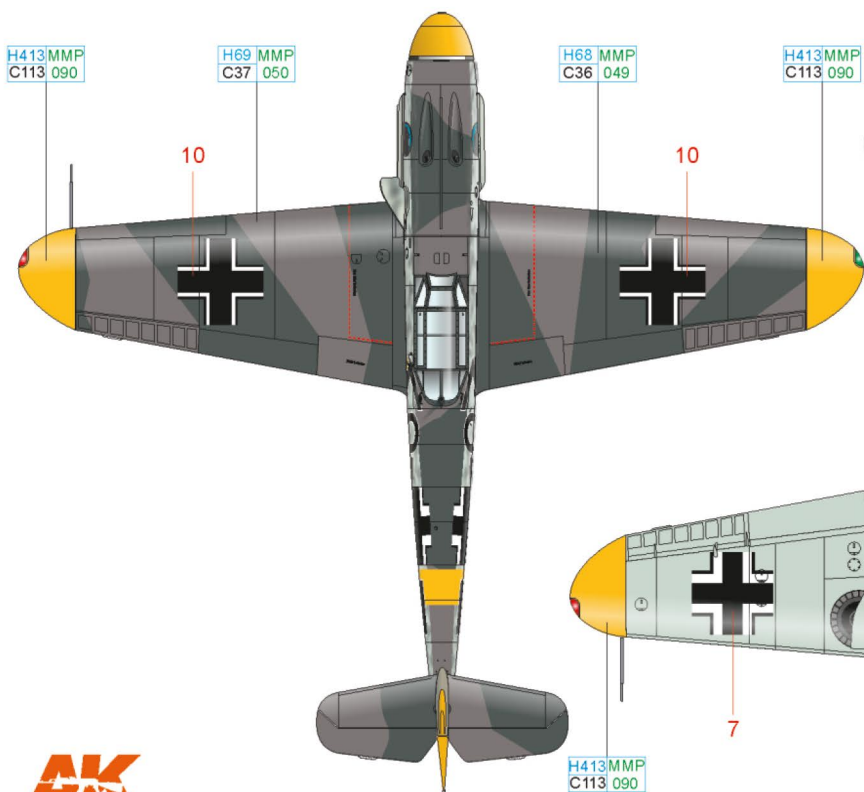
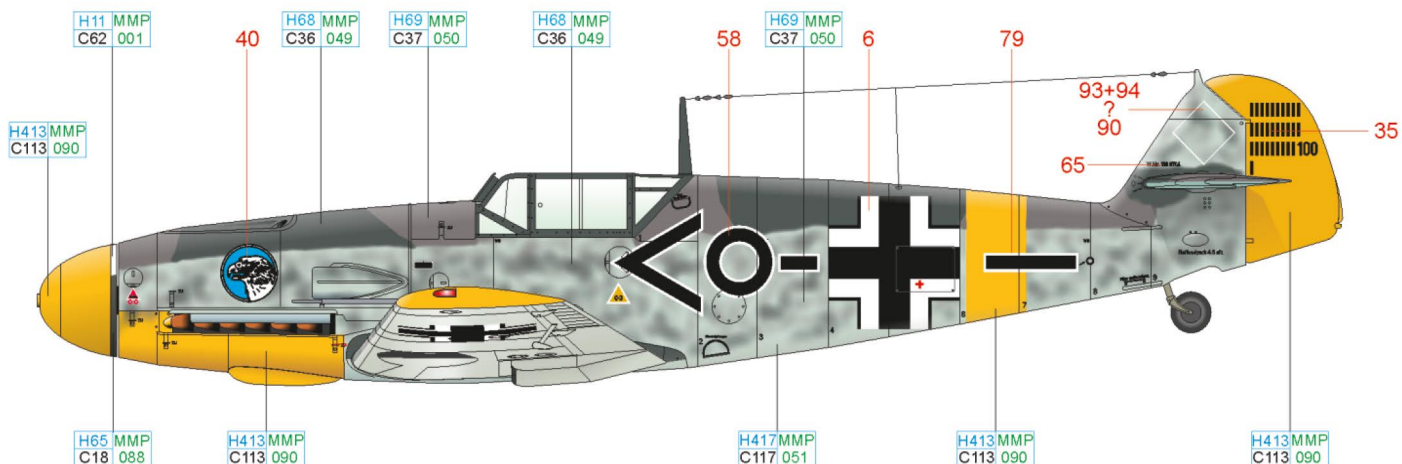

Special thanks to AK Interactive to cooperation on this project

ČESKOU VERZI TEXTU NALEZNETE NA [www.eduard.cz](http://www.eduard.cz) POD KATALOGOVÝM ČÍSLEM 11127

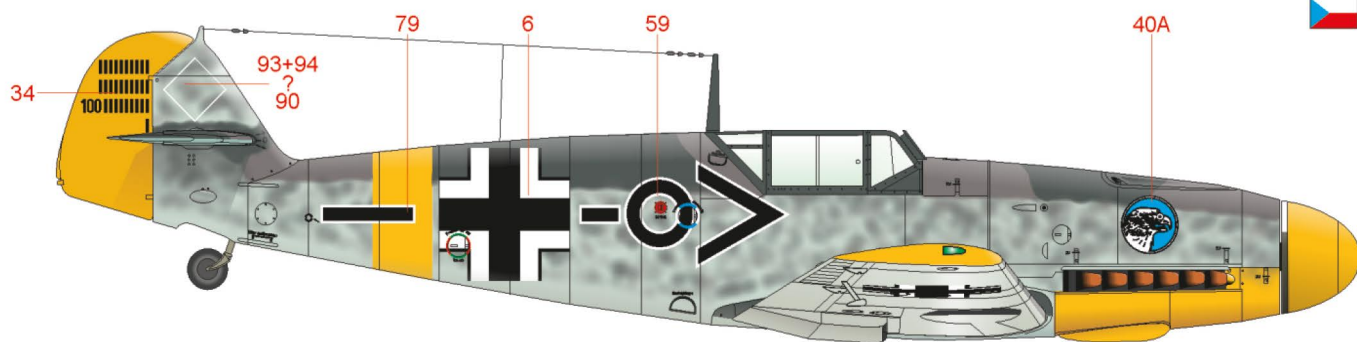

RLM 74	H68 MMP C36 049	RLM 70	H65 MMP C18 088	RLM 76	H417 MMP C117 051
RLM 75	H69 MMP C37 050	RLM 04	H413 MMP C113 090	WHITE	H11 MMP C62 001



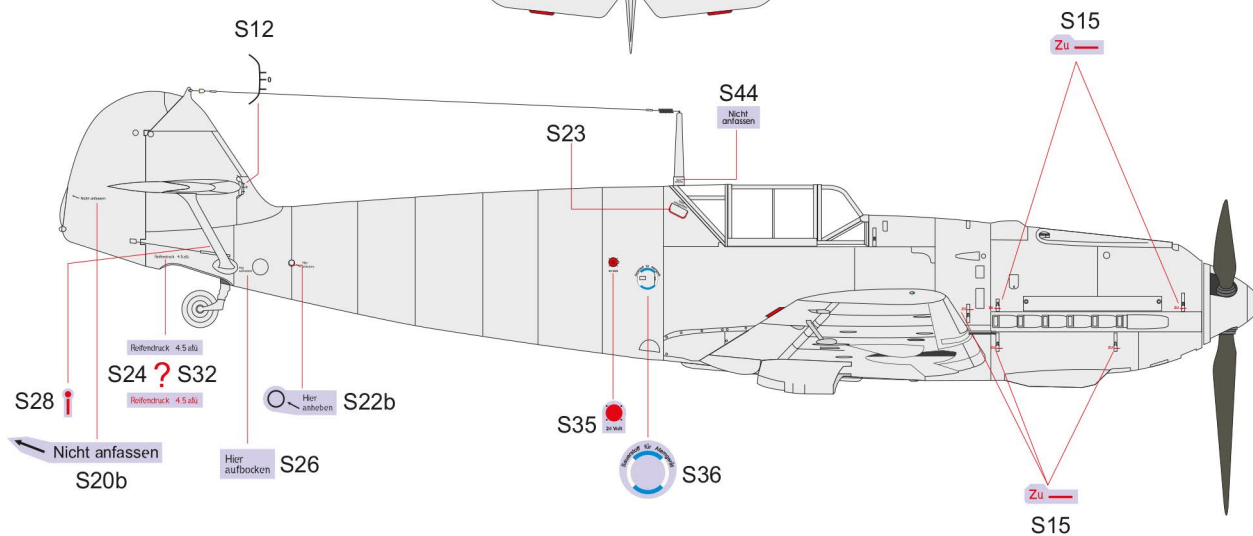
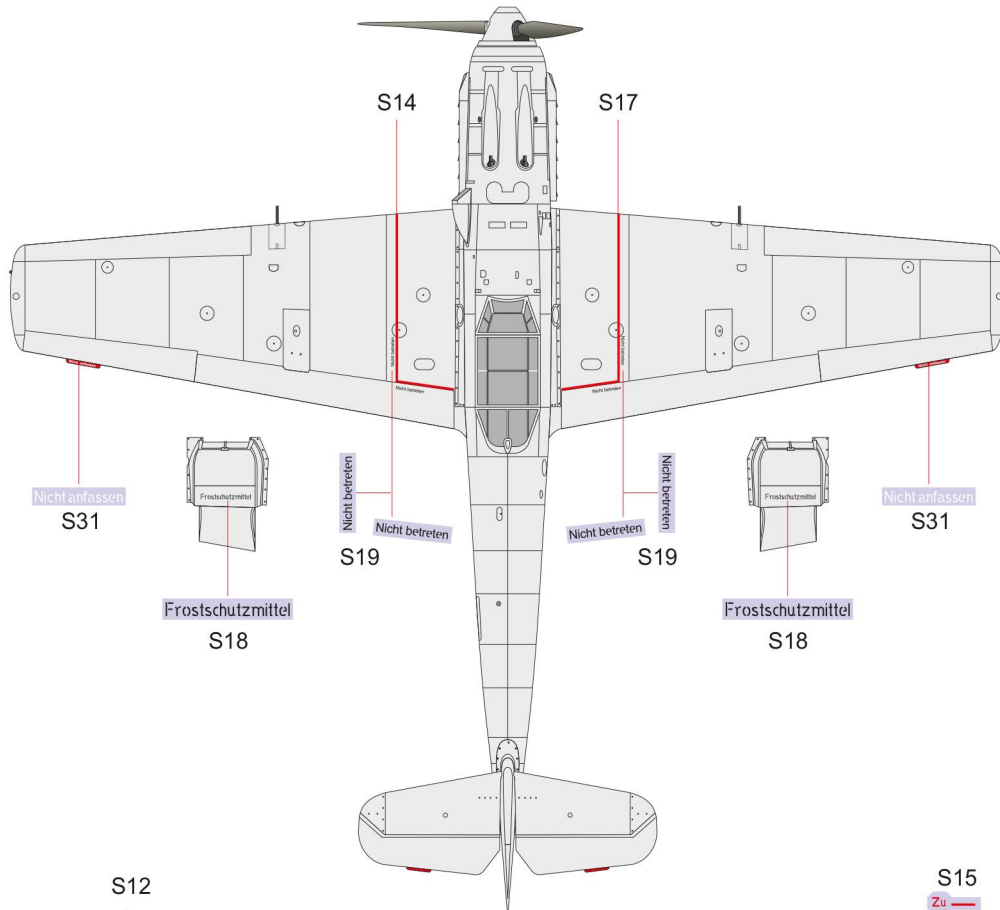
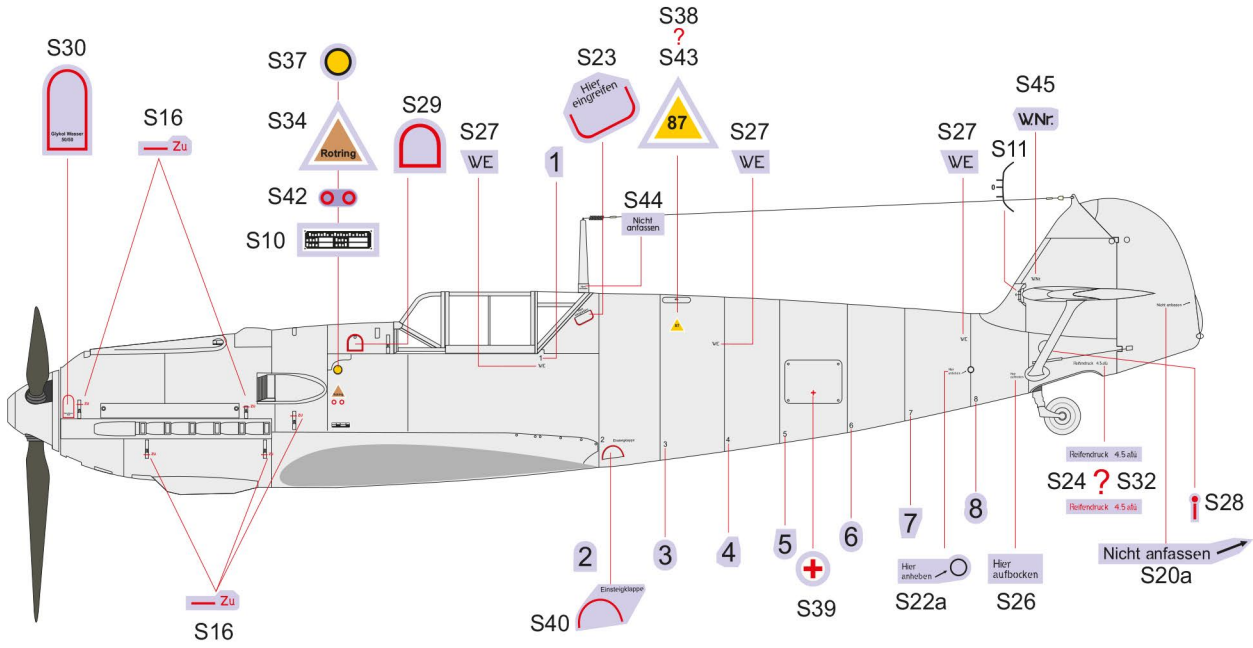



## RELATED PRODUCTS for Bf 109F-2:

- 49095 Seatbelts Luftwaffe WWII fighters STEEL 1/48 (PE-Set)
- 644010 Bf 109F LööK 1/48 (Brassin)
- 648282 Bf 109F wheels 1/48 (Brassin)
- 648279 Bf 109F cockpit 1/48 (Brassin)
- 648288 Bf 109F propeller LATE 1/48 (Brassin)
- 648289 Bf 109F propeller EARLY 1/48 (Brassin)
- 648291 Bf 109F landing flaps 1/48 (Brassin)
- 648292 Bf 109F control surfaces 1/48 (Brassin)
- 648300 Bf 109F engine and fuselage guns 1/48 (Brassin)
- 648308 Bf 109F undercarriage legs BRONZE 1/48 (Brassin)
- 648330 Bf 109F cockpit w/ early seat 1/48 (Brassin)
- 648332 Bf 109F&G Pitot tubes 1/48 (Brassin)
- 648365 Bf 109F radio compartment 1/48 (Brassin)
- EX588 Bf 109F TFace 1/48 (Mask)

Cat. No. 644010



Cat. No. 648365

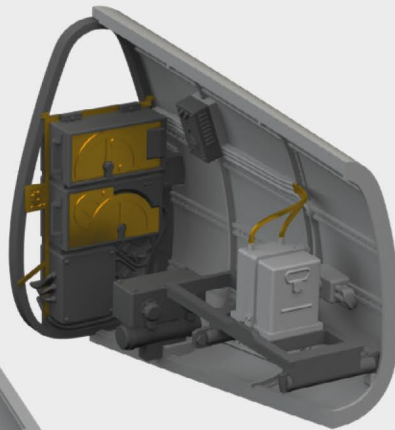
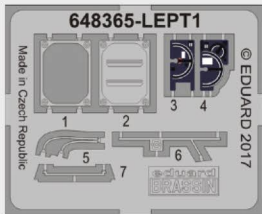

Cat. No. 648308



Cat. No. 648279

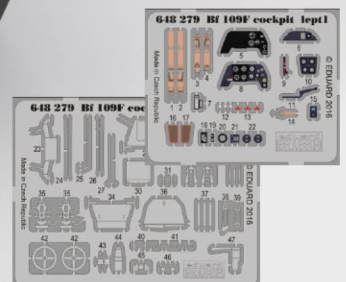
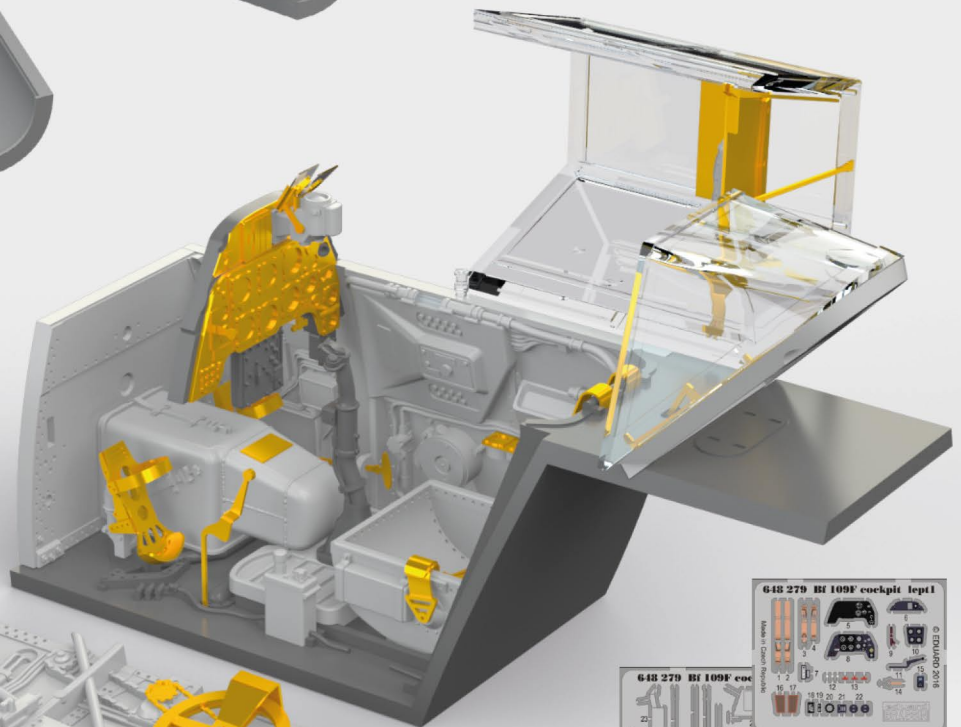
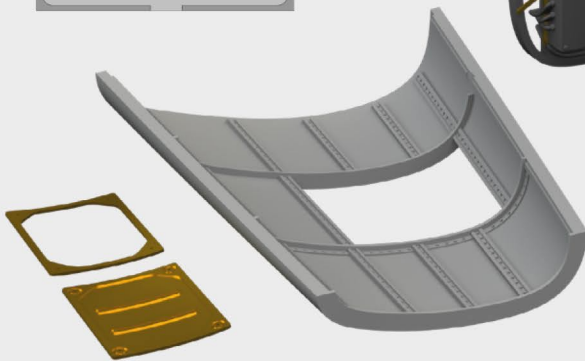

# Unternehmen

# 1/48

# BODENPLATTE

## Fw 190D-9 & Bf 109G-14, G-14/AS DUAL COMBO



- Eduard Bf 109G-14, G-14/AS and Fw 190D-9
- Plastic parts, photo-etched details and painting masks for two complete models
- Cartograf printed decals for 8 markings

Cat.No. 11125



Fw 190D-9, W. Nr. 500161,  
Gefr. Hans-Karl Götz, 7./JG 26



Bf 109 G-14/U4, W. Nr. 512335,  
Othmar Heberling, 2./JG 77



Fw 190D-9, W. Nr. 500093,  
Ogefr. Dieter Kragelöh, 3./JG 26



Fw 190D-9, W. Nr. 210079,  
Lt. Theo Nibel, 10./JG 54



Fw 190D-9, W. Nr. 210194,  
Fw. Werner Hohenberg, Stab 1./JG 2



Bf 109G-14/AS, W. Nr. 784993,  
Uffz. Herbert Maxis, 13./JG 53



Bf 109 G-14/AS, W. Nr. 784986,  
Otw. Paul Schwerdtfeger, 11./JG 6



Bf 109G-14, W. Nr. 781183,  
Uffz. Werner Zetzschke, 4./JG 4

**eduard**

**LIMITED EDITION**