

North American F-100F, 56-3950, 1 FDS, 413 DFW, George AFB, circa 1958, assigned aircraft of Lt.Col. Charles "Chuck" Yeager, the 1 FDS CO. (Ref: Sqn Signal C&M 14, P.48).

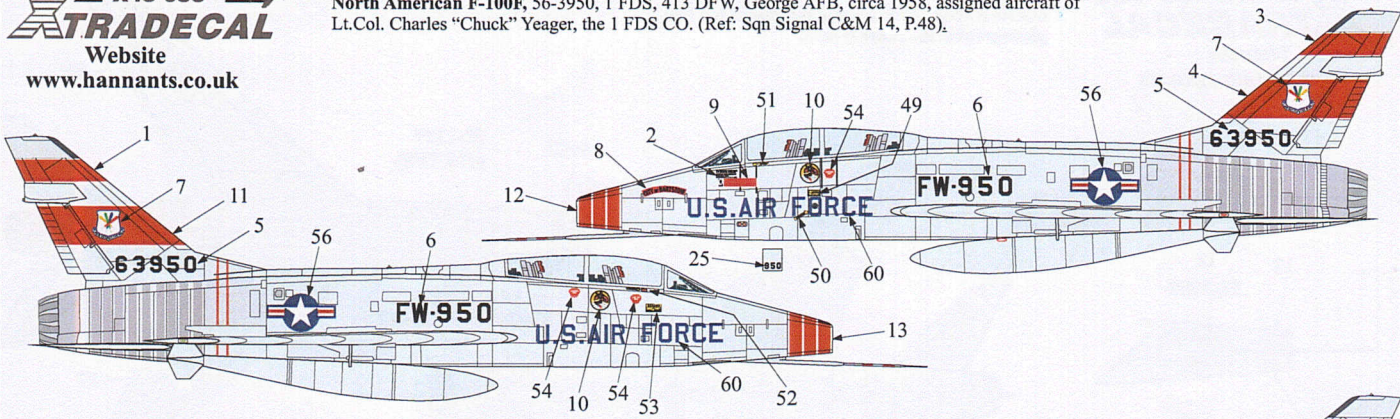

North American F-100F, 58-1227, 416 TFS, 21 TFW, Misawa AFB, Japan, October 1961. (Ref: Sqn Signal C&M 14, P.18),
In August 1959, the first single engine jet to fly over the North Pole.

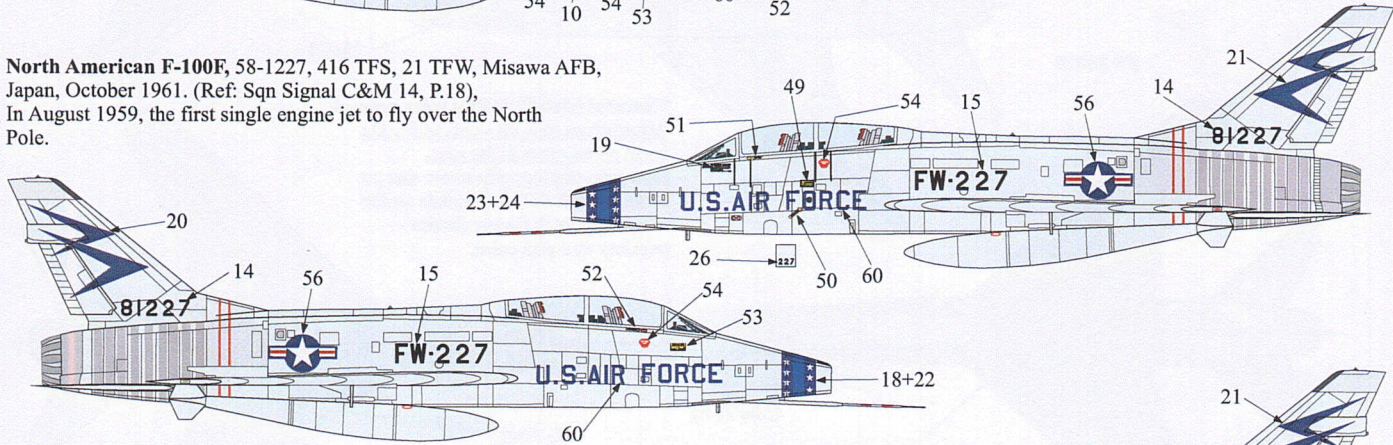

North American F-100D, 55-3608, 416 TFS, 21 TFW, Misawa, Japan, 1959. (Ref: DTU P.57).

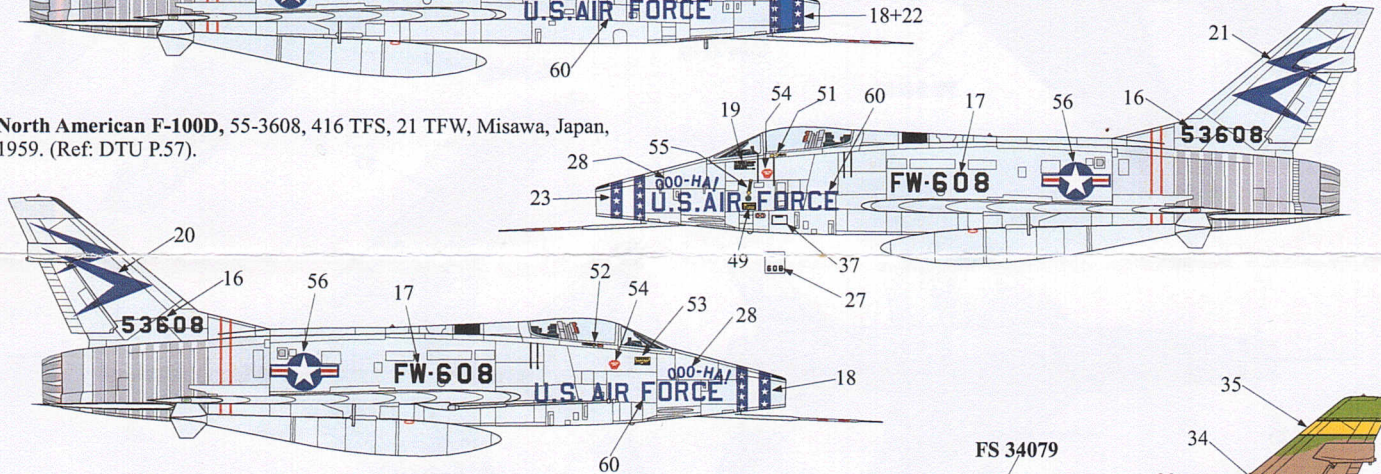

North American F-100F, 58-18227, 524 TFS, 27 TFW, Vietnam, "Wild Weasel" Ops, circa late 1960's/early 1970's. (Ref: Sqn Signal C&M 14, P.22)

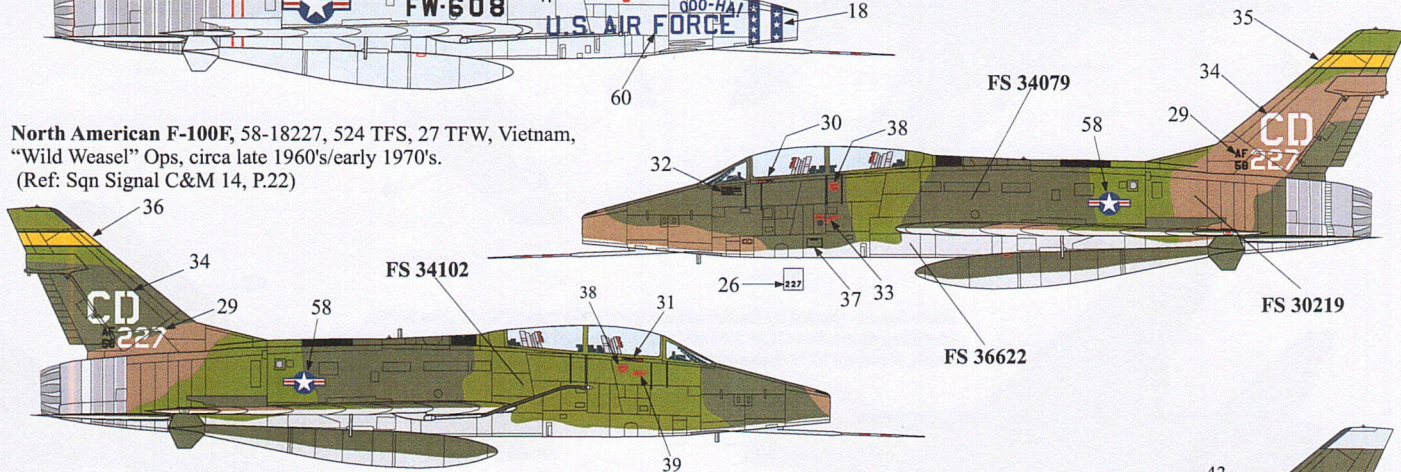

North American F-100D, GT-971 (ex-56-3971) of Esk 727, Royal Danish Air Force, circa late 1970's. (Ref: Jens Jensen photo).

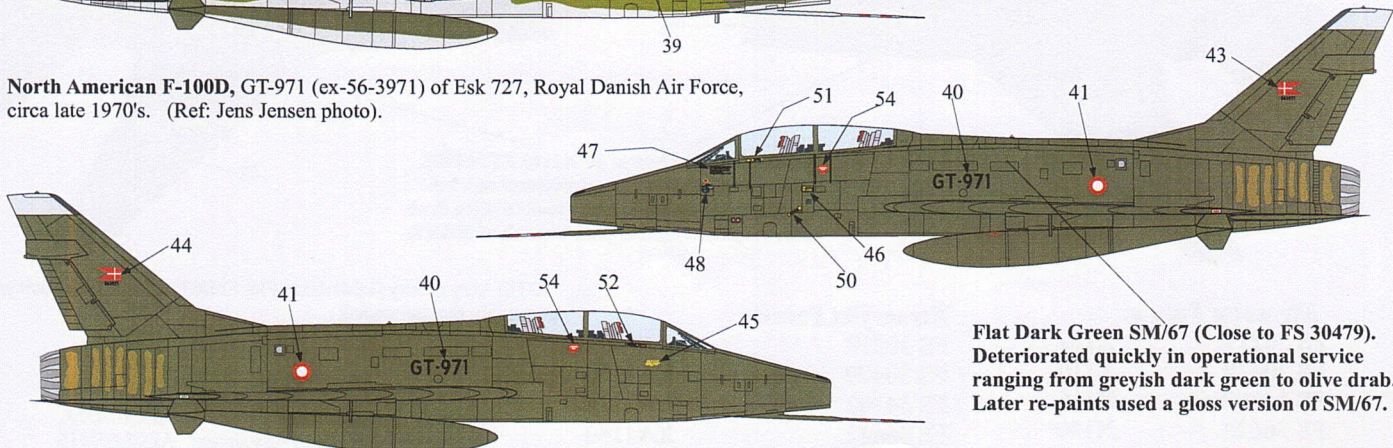

Flat Dark Green SM/67 (Close to FS 30479). Deteriorated quickly in operational service ranging from greyish dark green to olive drab. Later re-paints used a gloss version of SM/67.

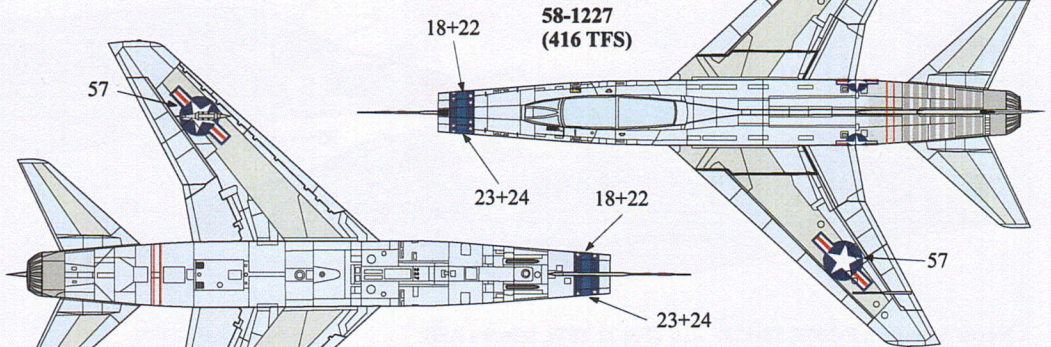
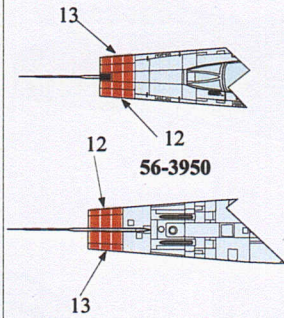

“Natural Metal” F-100s were painted Aluminium overall - except for the burnt metal areas at the rear. However, photographs show that on some aircraft different panels on the wings appear in darker shades - possibly anti-slip paint.

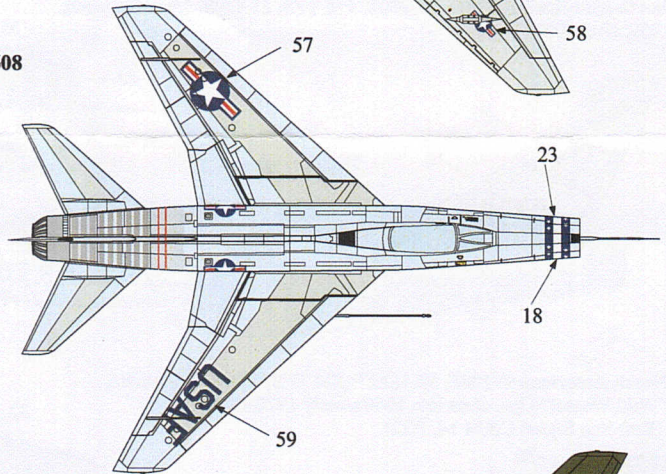
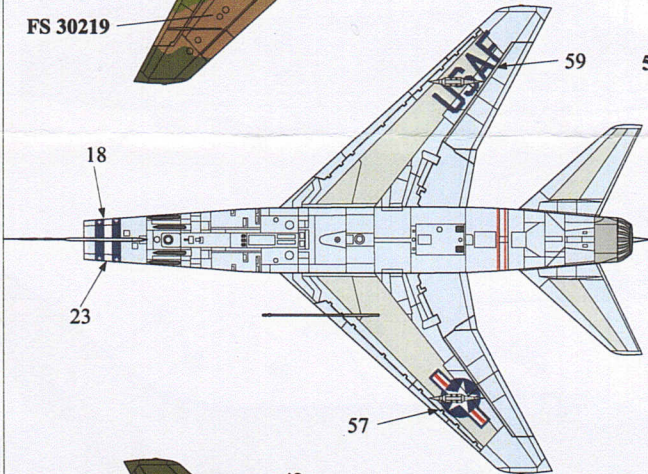
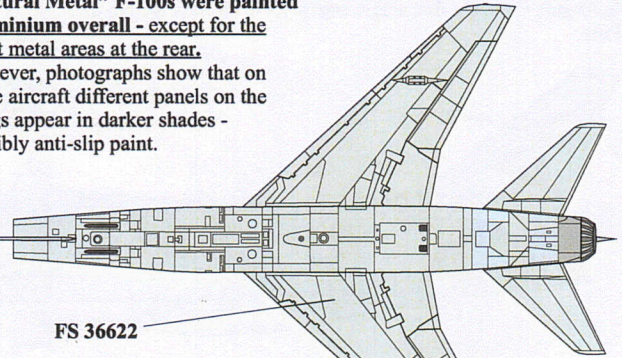
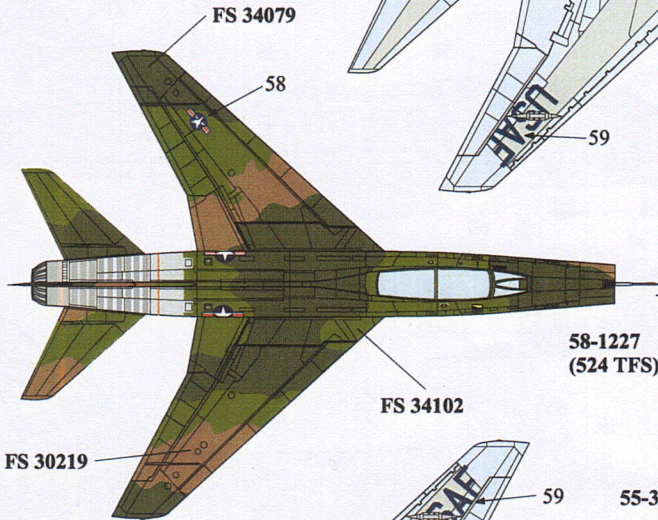

Dark Green: Quoted by Danish authority as in the range FS14062 to 14066. Matching shows that Gloss Xtracolor X110 (FS14079) will simulate the required finish. Humbrol HU3 Brunswick Green would also be suitable.

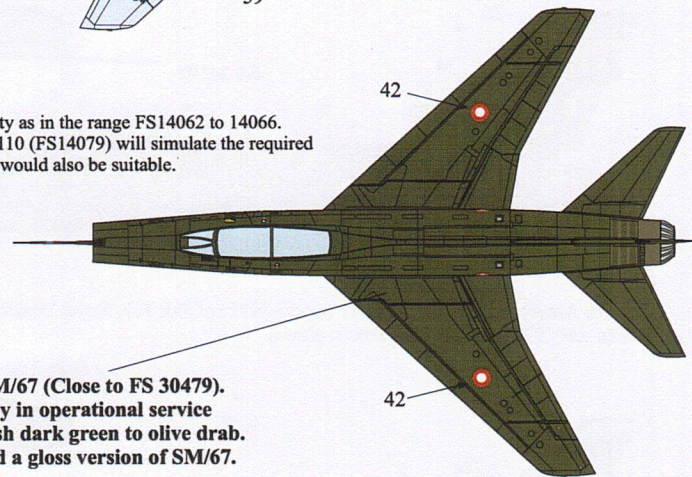
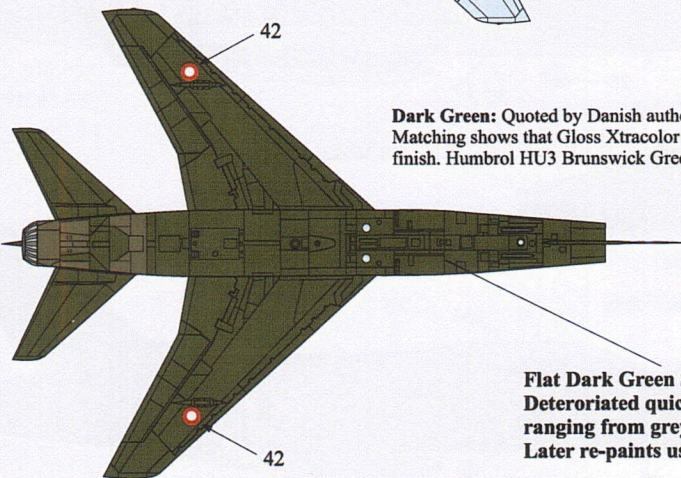

Flat Dark Green SM/67 (Close to FS 30479). Deteriorated quickly in operational service ranging from greyish dark green to olive drab. Later re-paints used a gloss version of SM/67.

NOTE: Very patchy finish using Flat SM/67, reference to photographs is strongly recommended.

Xtracolor Paints:

FS 30219	X102
FS 30479	X110
FS 34102	X116
FS 36622	X140
Aluminium	X142

Xtracrylix Paints:

FS 30219	XA1102
FS 30479	XA1110
FS 34102	XA1116
FS 36622	XA1140
Silver (Silber)	XA1216

Alclad Paints: For spraying only

Alclad2 Aluminium	ALCLAD2A
Alclad116 Semi-Matt Aluminium	ALCLAD116

(For rest of range see Website)