

TIGER I EARLY-PRODUCTION MODEL WITH STEEL WHEELS w/Zimmerit Gruppe "Fehrmann"

Sd.Kfz.181 Pz.Kpfw.VI Ausf.E

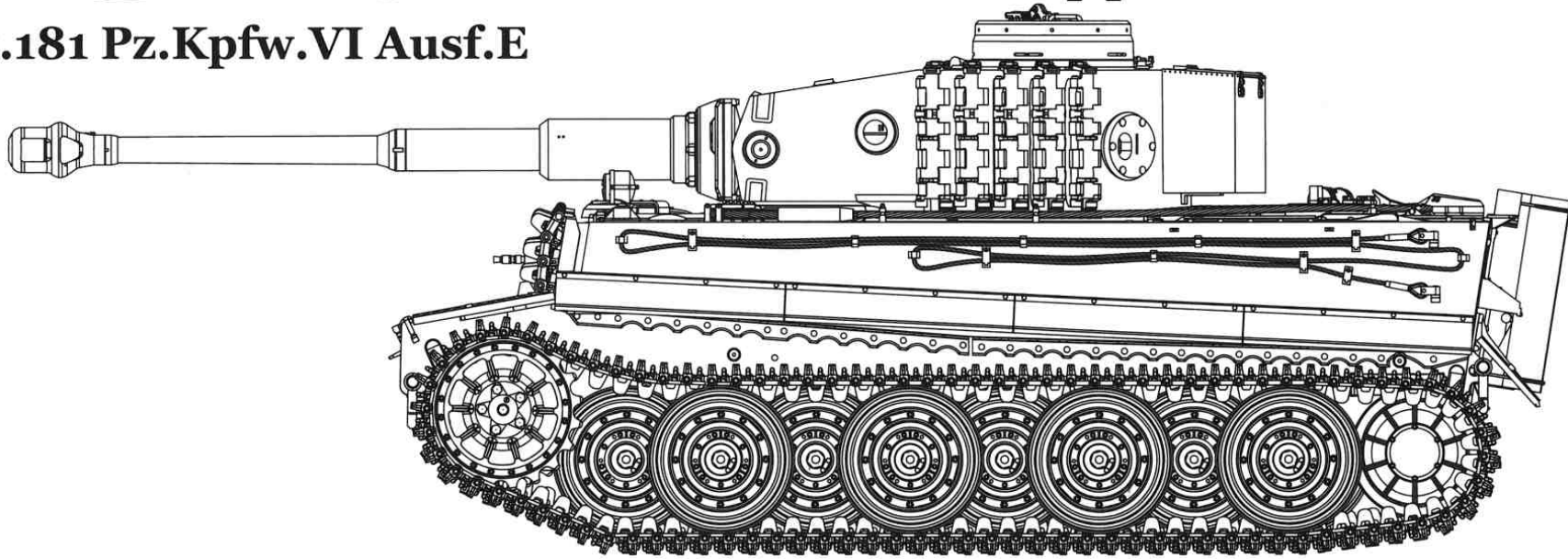

WSM

The legendary Tiger tank was arguably Nazi Germany's most feared weapon on the battlefields of Europe & North Africa during WWII. With its heavy armor and powerful cannon, the massive Tiger easily dominated most confrontations against its opponents. The mere sight of a Tiger often terrorized Allied troops without firing a shot. Nevertheless, the mighty Tiger suffered its own share of shortcomings, and Allied forces eventually learned how to defeat it in combat.

In the years leading up to WWII, the Germans began studying heavier tank designs to defeat the heavy French Char 2C and B1 tanks. These studies ultimately led to the development of the VK 36.01 prototype (built by Henschel) and the VK 45.01 prototype (built by Porsche). By this time, the Germans had been humiliated on the Eastern Front by the Soviet T-34 & KV-1 tanks, which proved the necessity for a heavier tank. After much competition and many changes along the way, the winner of the contract for a production vehicle was awarded to Henschel, whereas the Porsche prototypes were used to make the Sd.Kfz.182 Elefant/Ferdinand tank destroyers. Production of the Sd.Kfz.181 Tiger I began in May 1942 and lasted until August 1944, with continuous modifications & improvements being made throughout the entire production of 1347 units.

The Tiger I was armed with the formidable Krupp 88mm KwK 36 L/56 main gun, which was derived from the proven 88mm Flak 18 and Flak 36 guns. It primarily fired PsGr.39 Armor Piercing, Capped, Ballistic Capped (APCBC) shells at a muzzle velocity of 780 meters per second and Pz.Gr.40 Armor-Piercing Composite Rigid (APCR) shells at a muzzle velocity of 930 meters per second, with a range of 10,500 meters. The gun could be reloaded in around 11 seconds, resulting in a potential rate of fire of approximately 6 rounds per minute. An MG 34 was mounted coaxially with the main gun, a second mounted in the bow, and a third mounted externally on the commander's cupola.

Five men crewed the Tiger I, consisting of the commander, gunner, and loader in the turret, and the driver and radio operator in the front of the hull. The 56-ton tank was initially powered by the Maybach HL 210 TRM P45 21-liter V-12 engine producing 650 hp, but this was later replaced by the more powerful Maybach HL 230 TRM P45 23-liter V-12 engine producing 700 hp from May 1943. Armor protection consisted of 102mm thick homogenous steel plates at the front of the bow, 62mm thick armor plates on the lower hull sides, 82mm thick armor on the upper hull sides and turret sides, 97mm thick armor on the front of the turret (with up to 200mm thickness being added by the cast mantlet), 82mm thick armor on the rear hull, and 26mm thick armor on the floor and roof (with the roof thickness being increased to 40mm in September 1943).

Kampfgruppe Fehrmann was composed of tank school instructors and their training tanks. There were around 6 Tigers, 5 Panthers and 2 half-tracks (F01-F13). The Tigers were under the command of Oberleutnant Fehrmann and the Panthers were led by Major Schulze. On April 6, 1945, the Kampfgruppe attempted to break into the Ruhr pocket, but Fehrmann was captured during a counterattack while assaulting US positions on April 11, so Schulze was left in command.

READ BEFORE ASSEMBLY

CAUTION

- Read carefully and fully understand the instructions before commencing assembly. A supervising adult should also read the instructions if a child assembles the model.
- When assembling this kit, tools including knives used. Extra care should be taken to avoid personal injury.
- Keep out of reach of small children. Children must not be allowed to suck any part, or pull vinyl bag over their heads.



Be Careful



Optional



Instant Glue for Metal



Remove



Drill



Do Not Cement

APPLYING DECALS

1. Clean the model surface with a wet cloth.
2. Cut out each decal design from sheet, and dip it in tepid water for 15~20 sec.
3. Hold the backing sheet edge and slide decal onto the model.
4. Move decal into position by wetting decal with finger.
5. Press decal gently down with a soft cloth until excess water and air bubbles are gone.

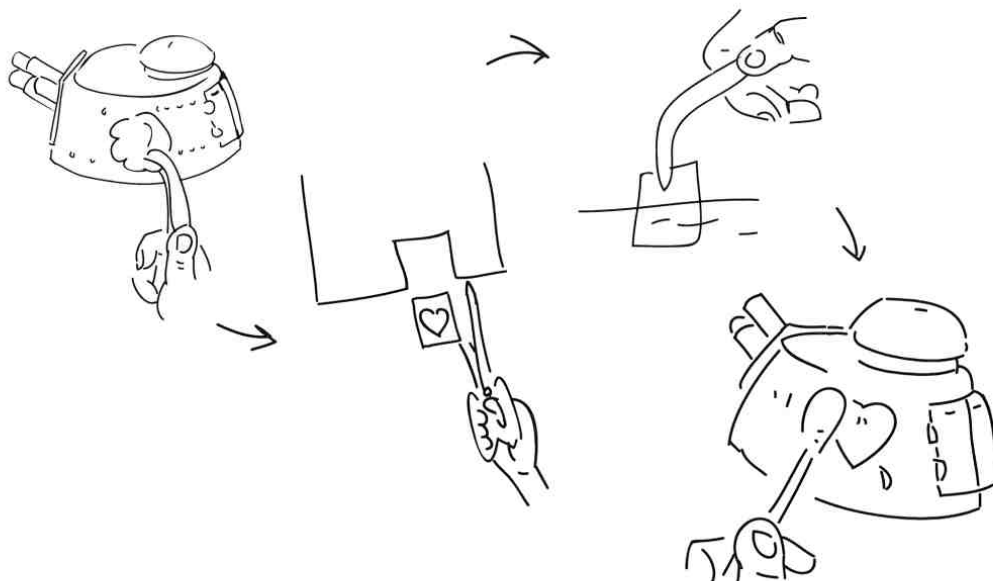

REMOVING PE

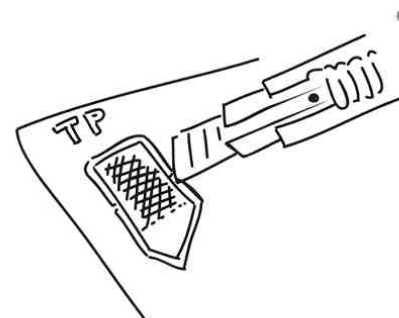

Be careful not to hurt when removing PE parts.

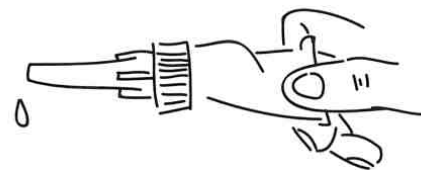

Secure using instant glue (not included).

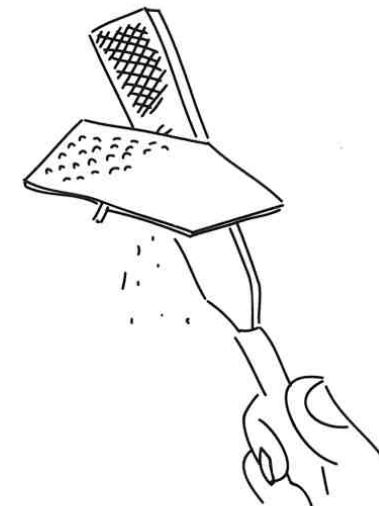

Finish using file.

PARTS

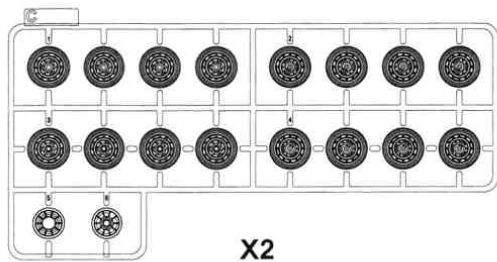

X2

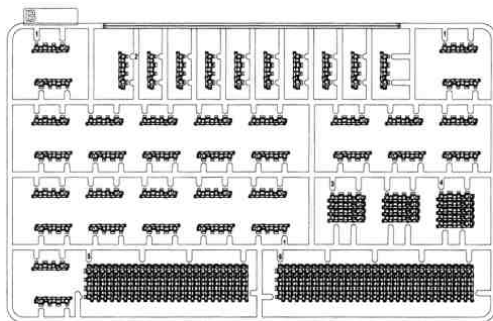

X2

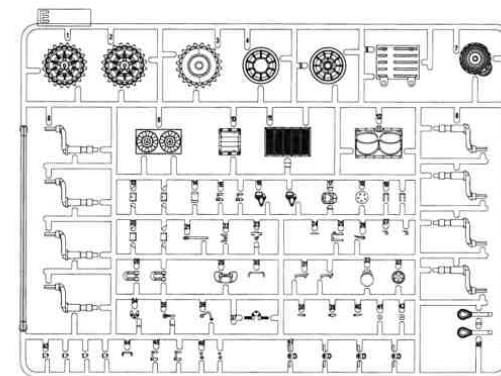
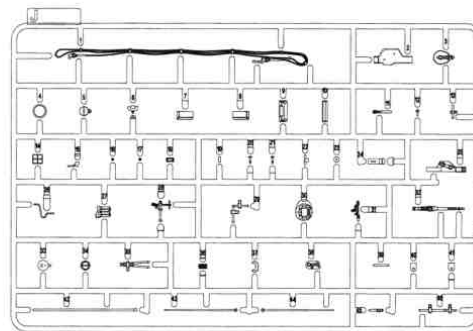

X2

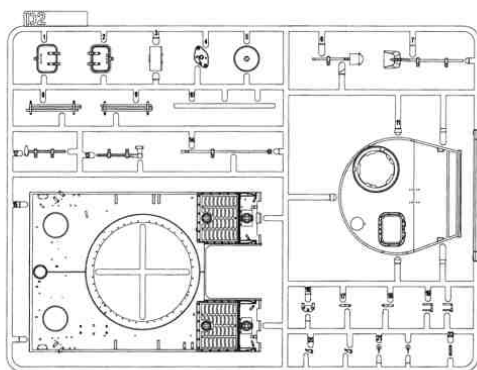
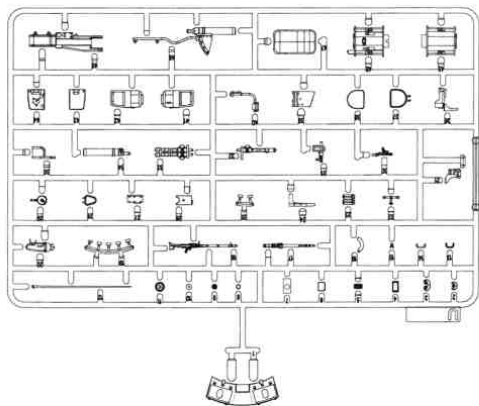
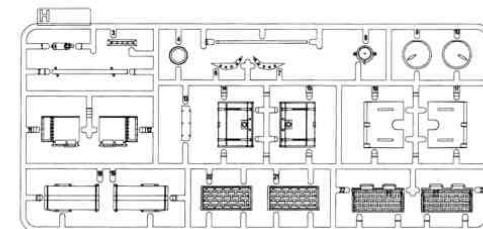
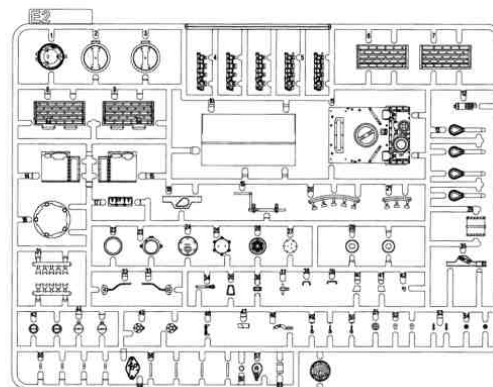
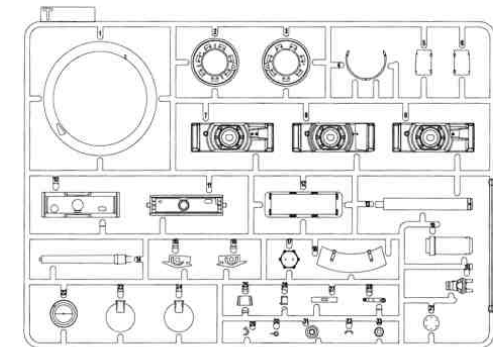
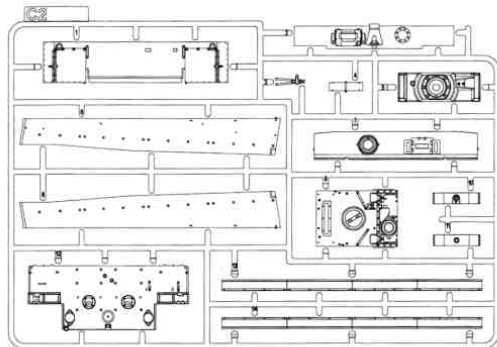

A2



B2

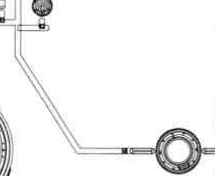

Cable

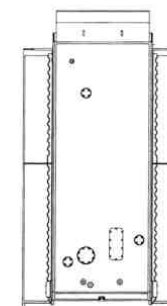

Q



Metal Barrel



TP

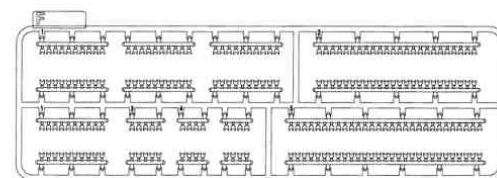
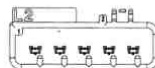
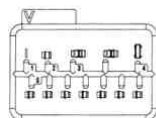
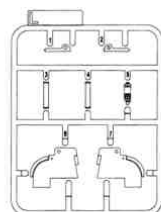
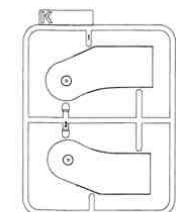

X2

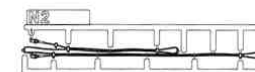

Decal

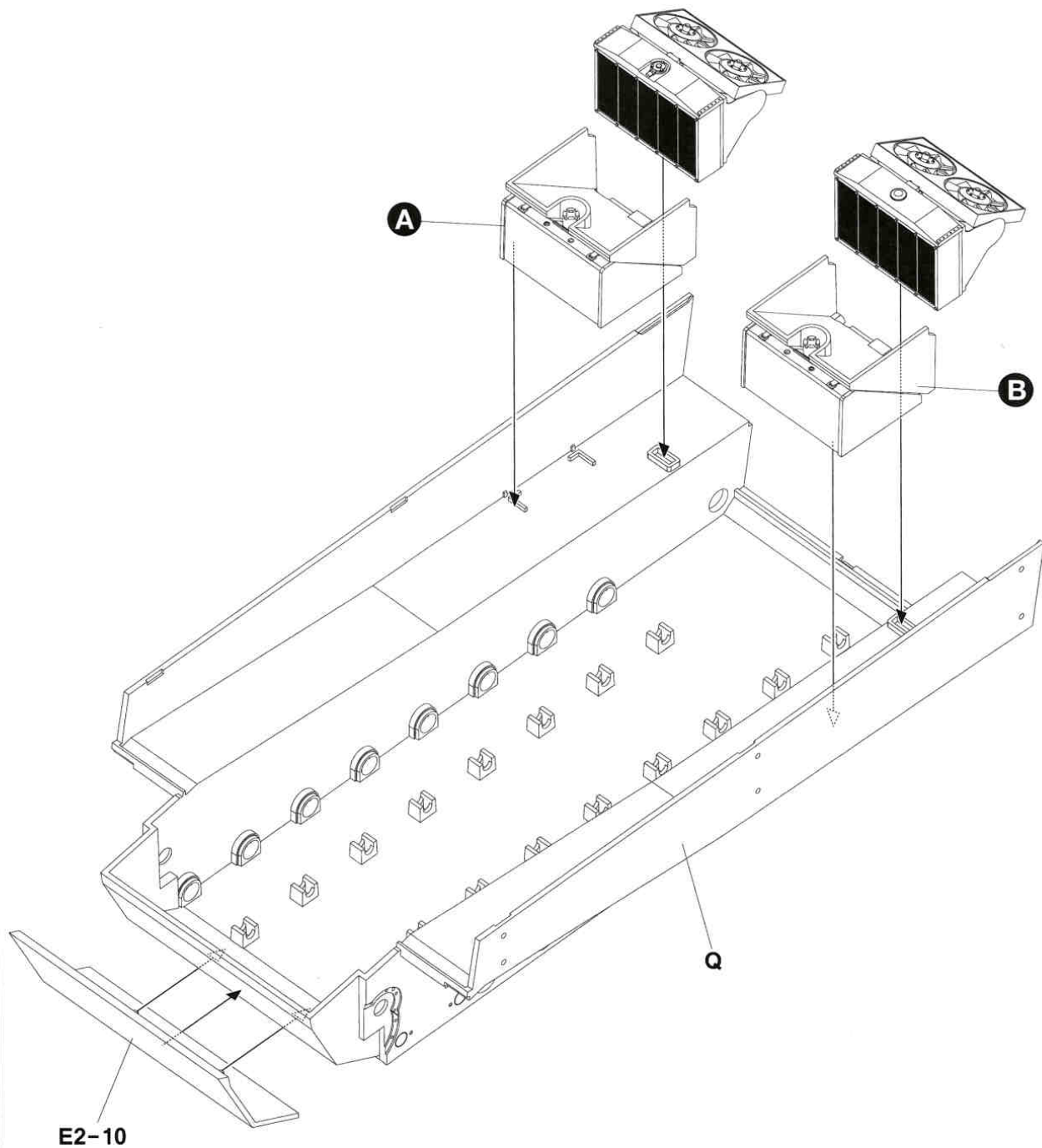
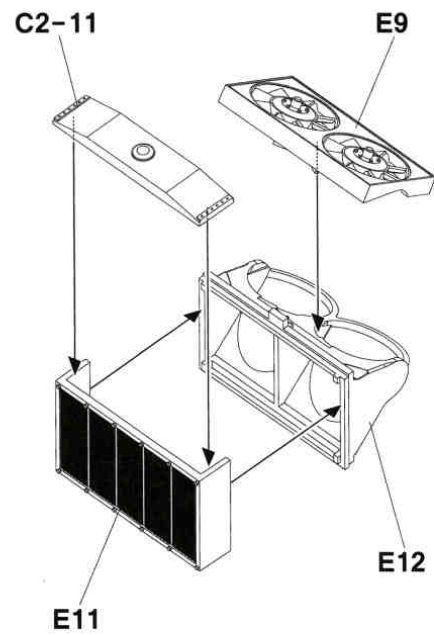
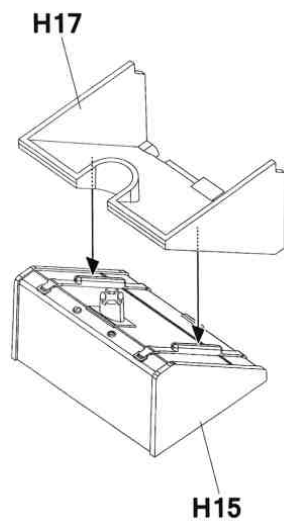
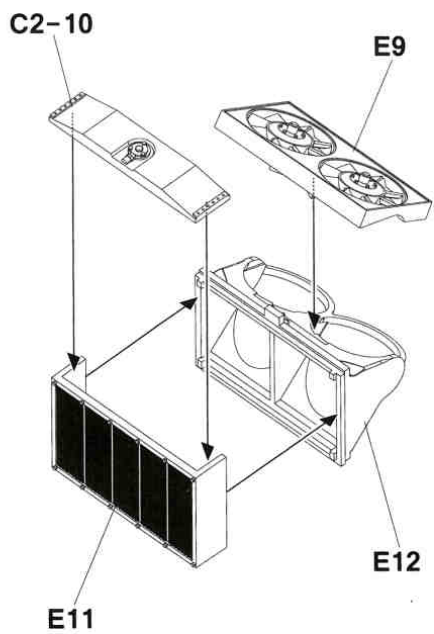
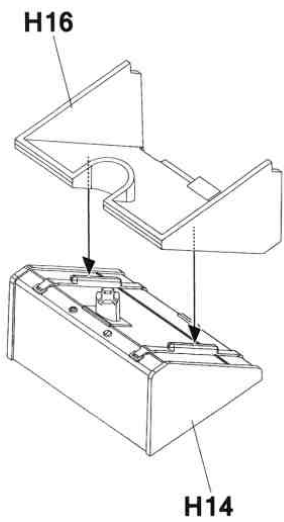
1**3**

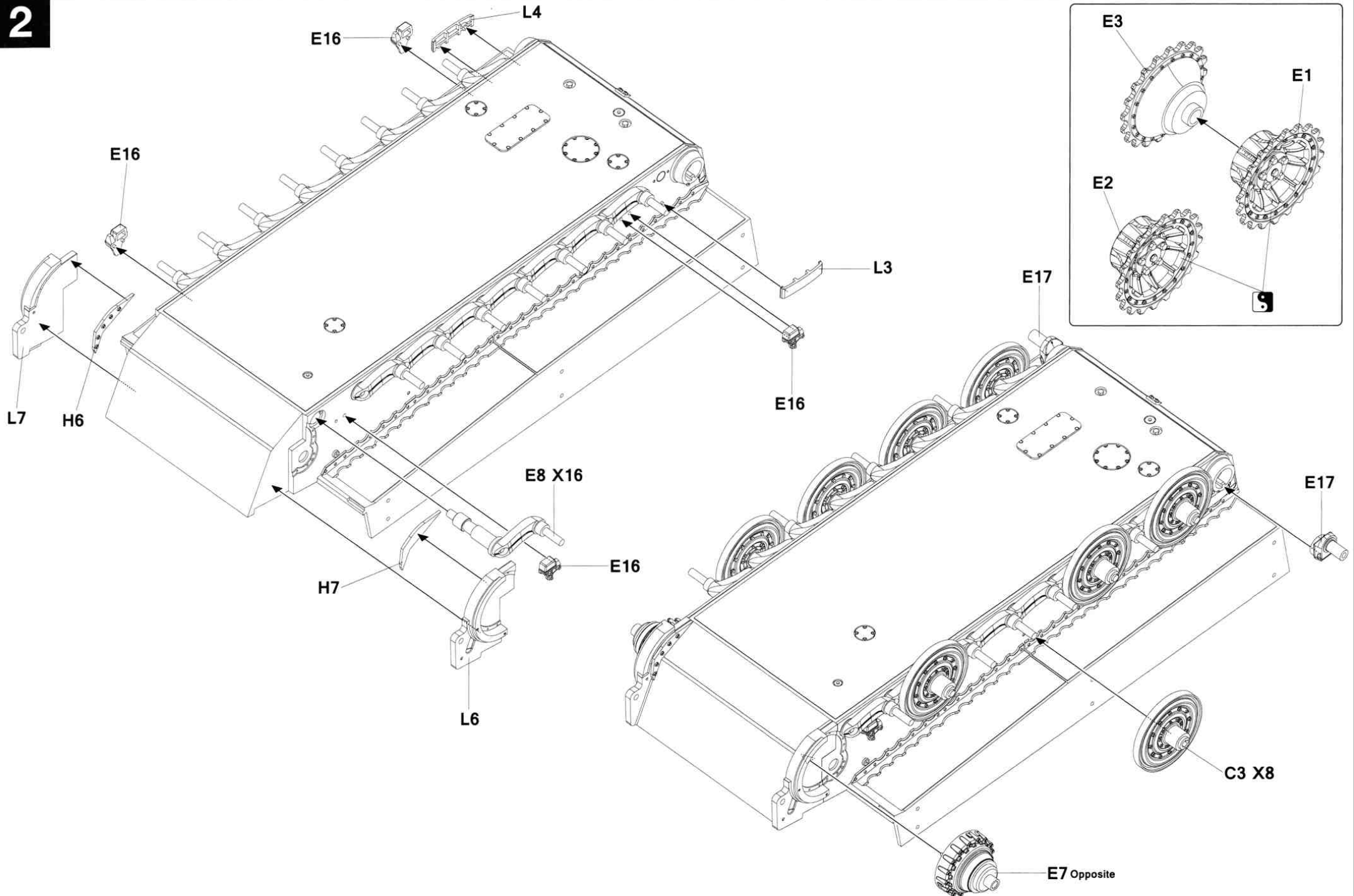

3

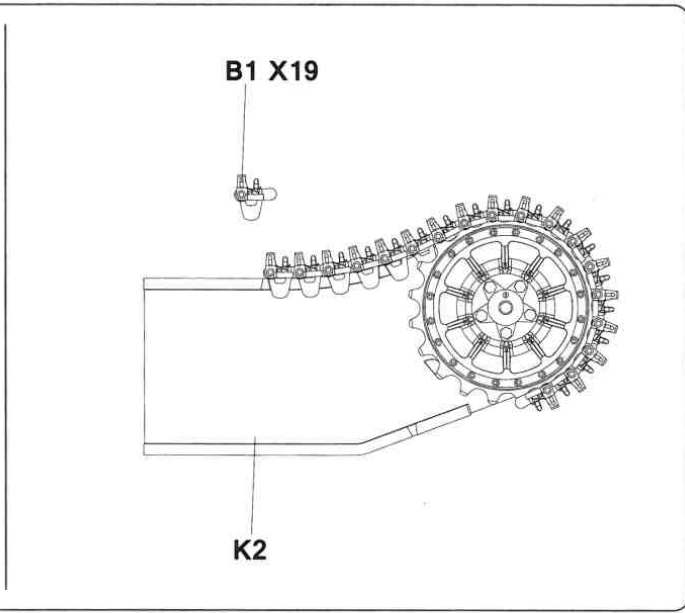
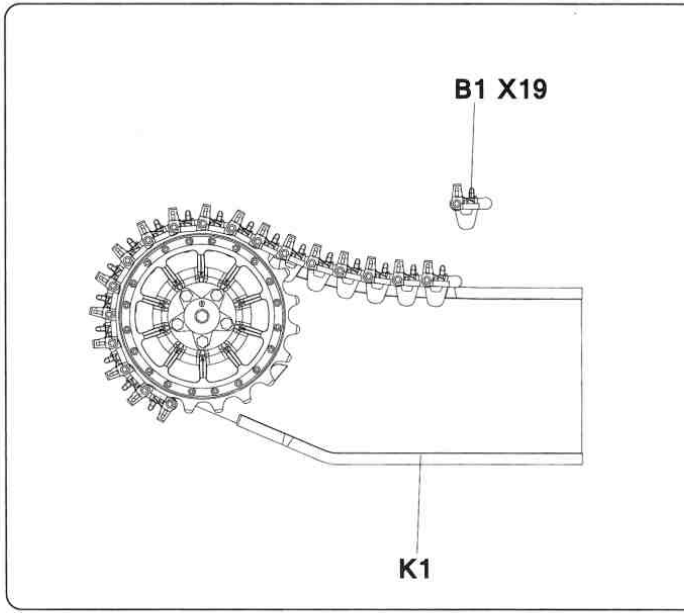
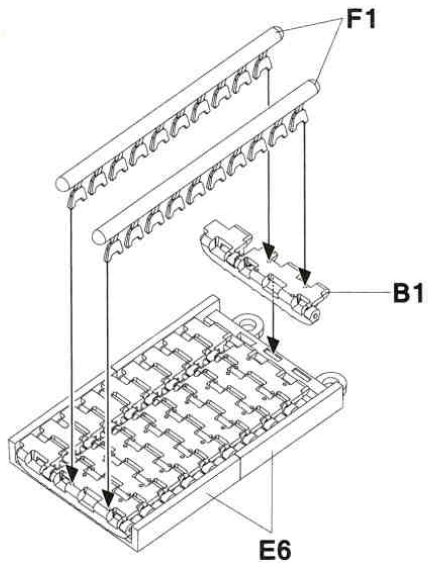
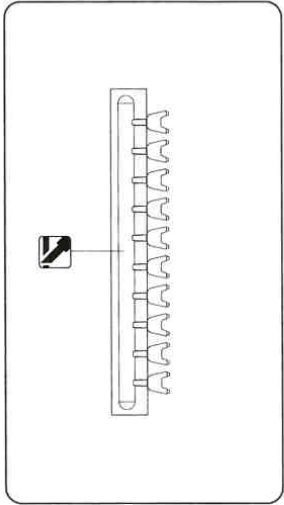

4

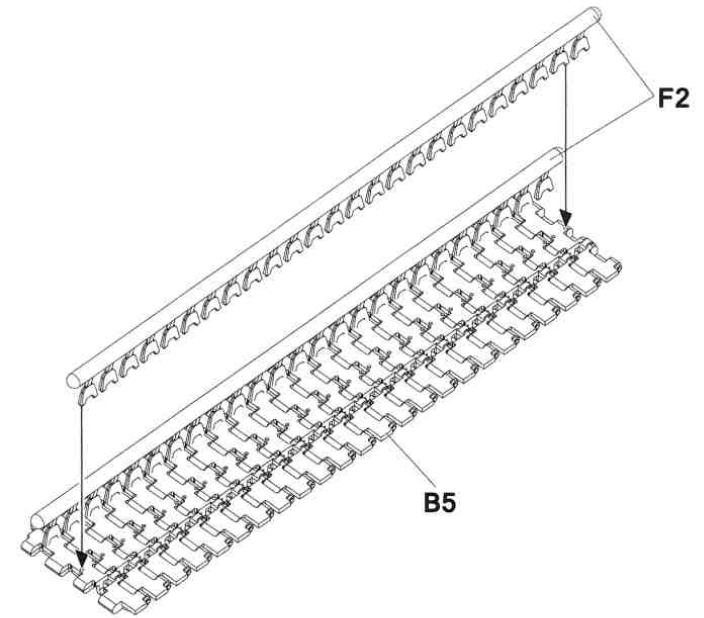
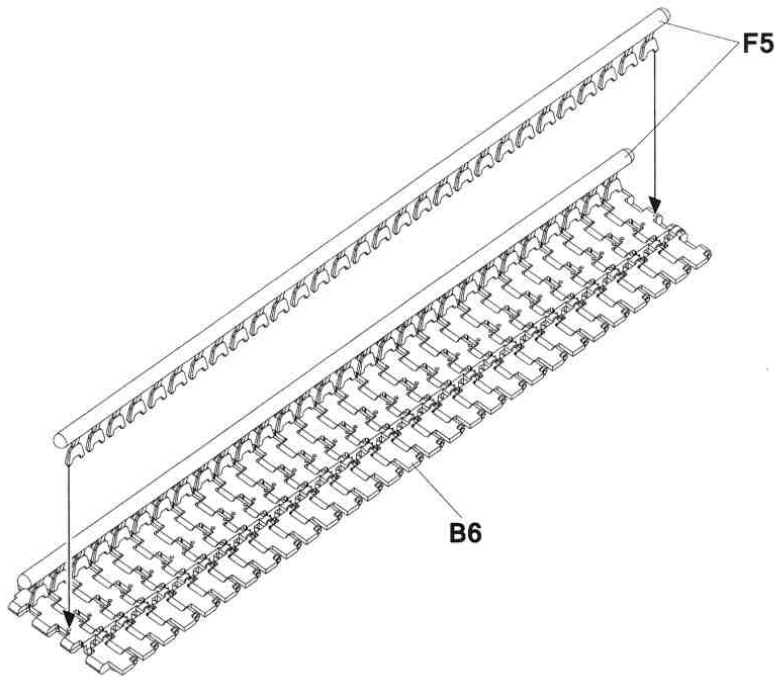
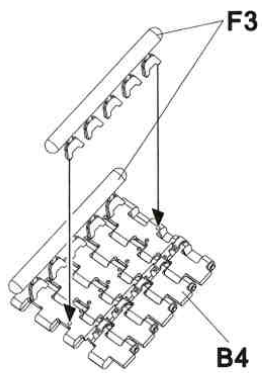
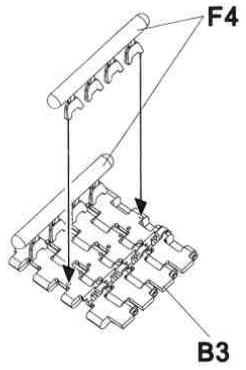

5

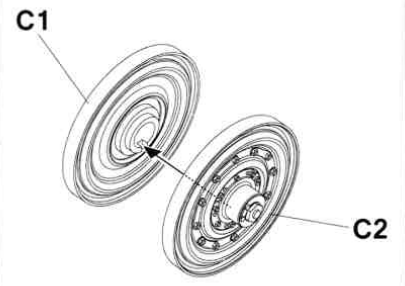
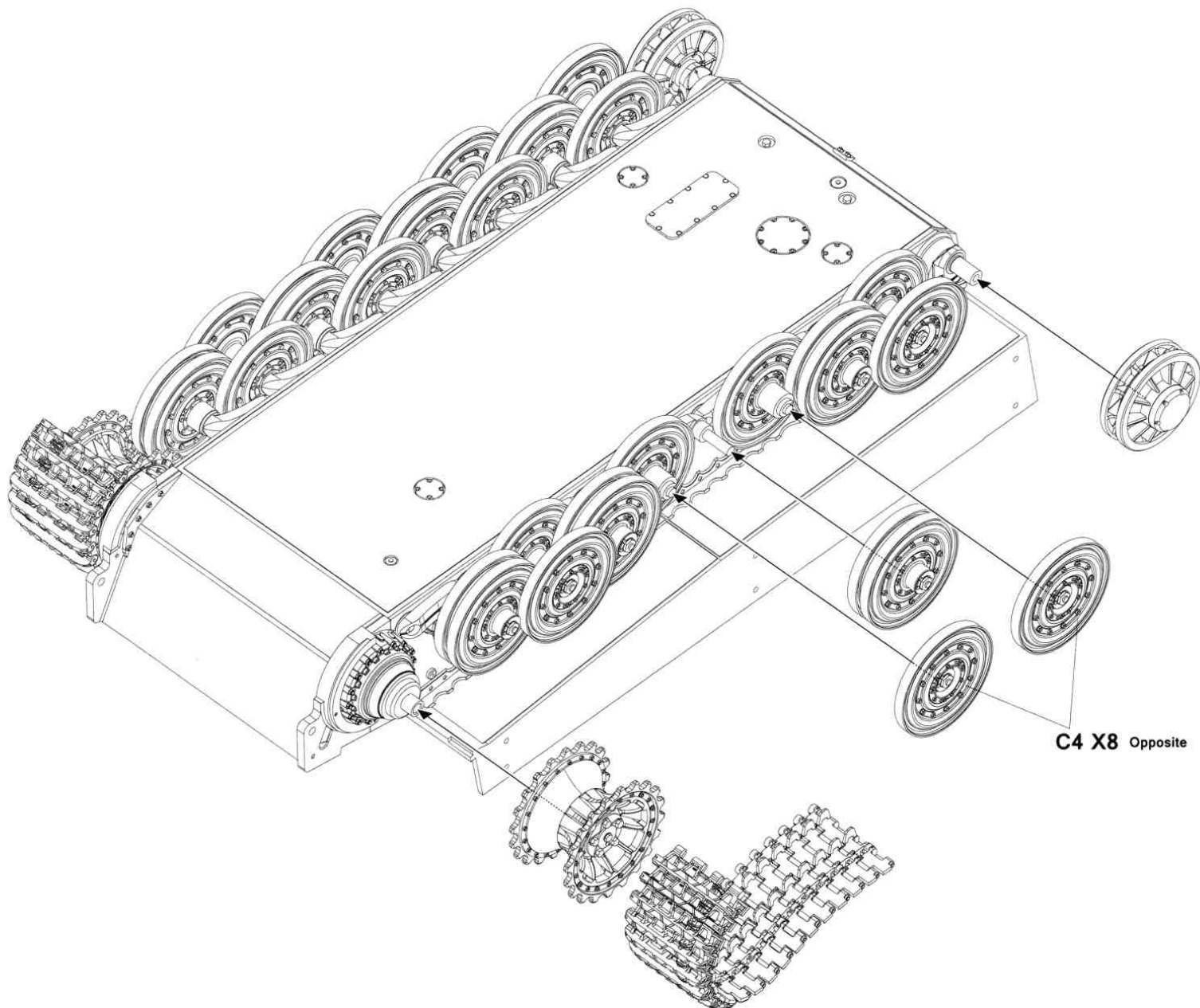

Make 8

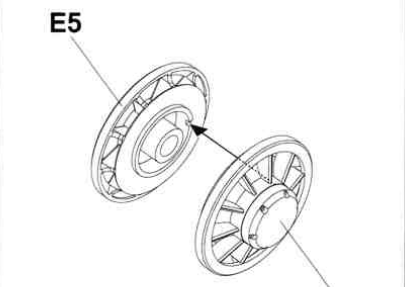

Make 2

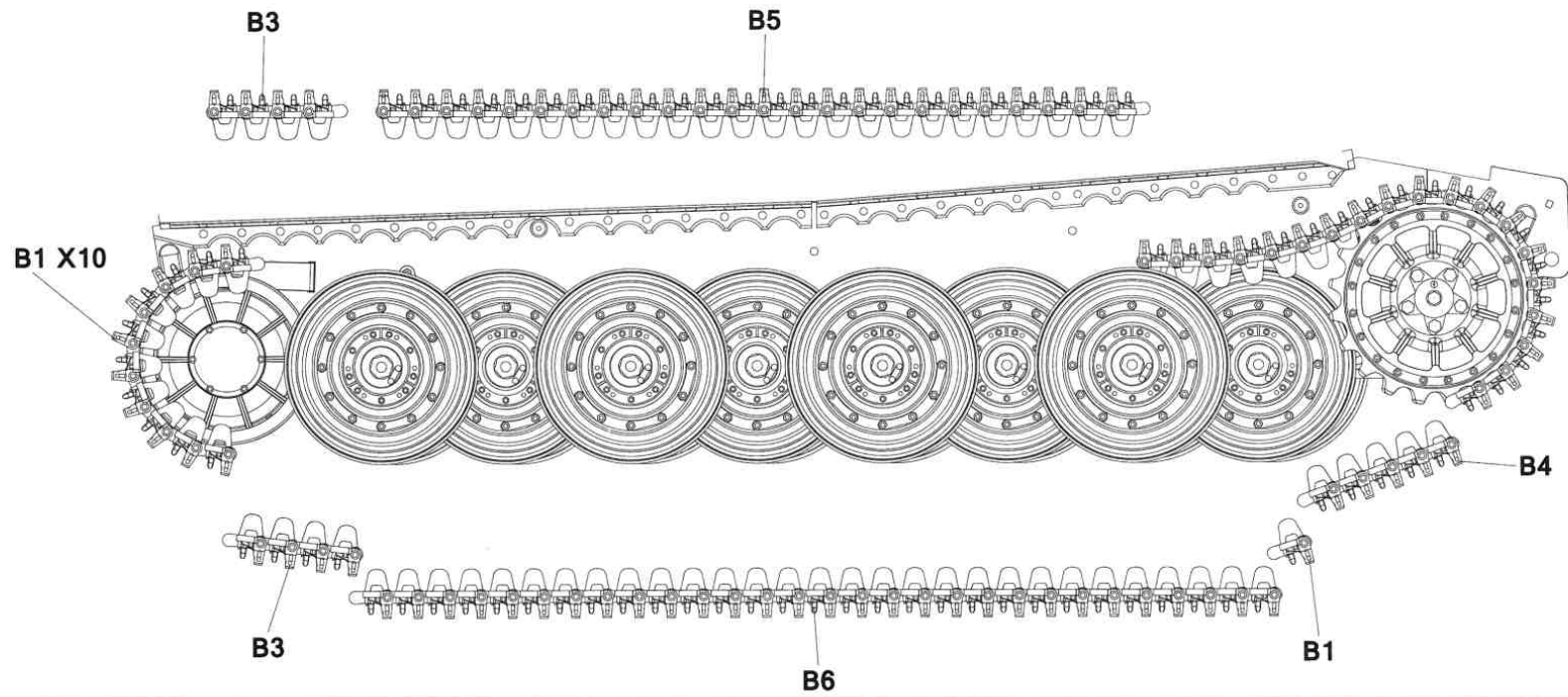
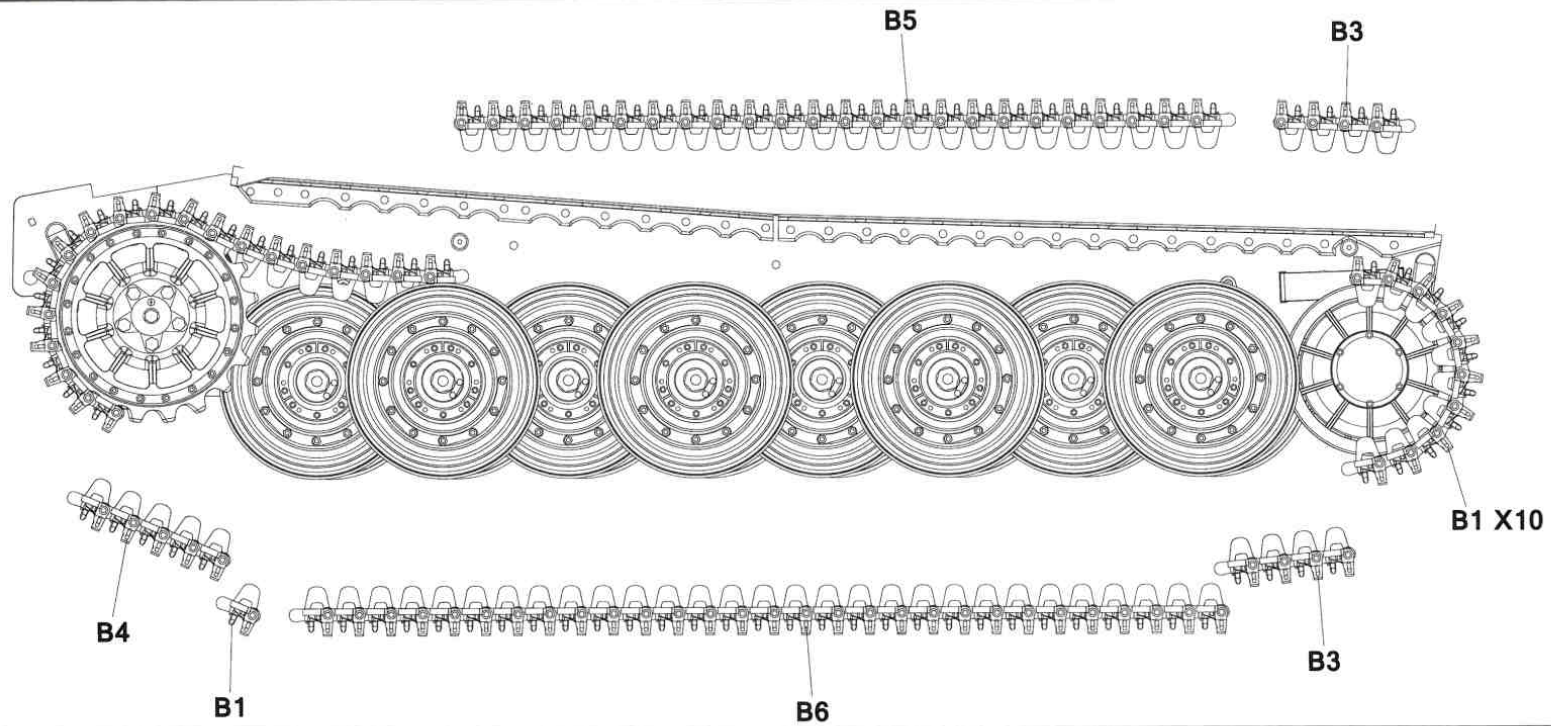

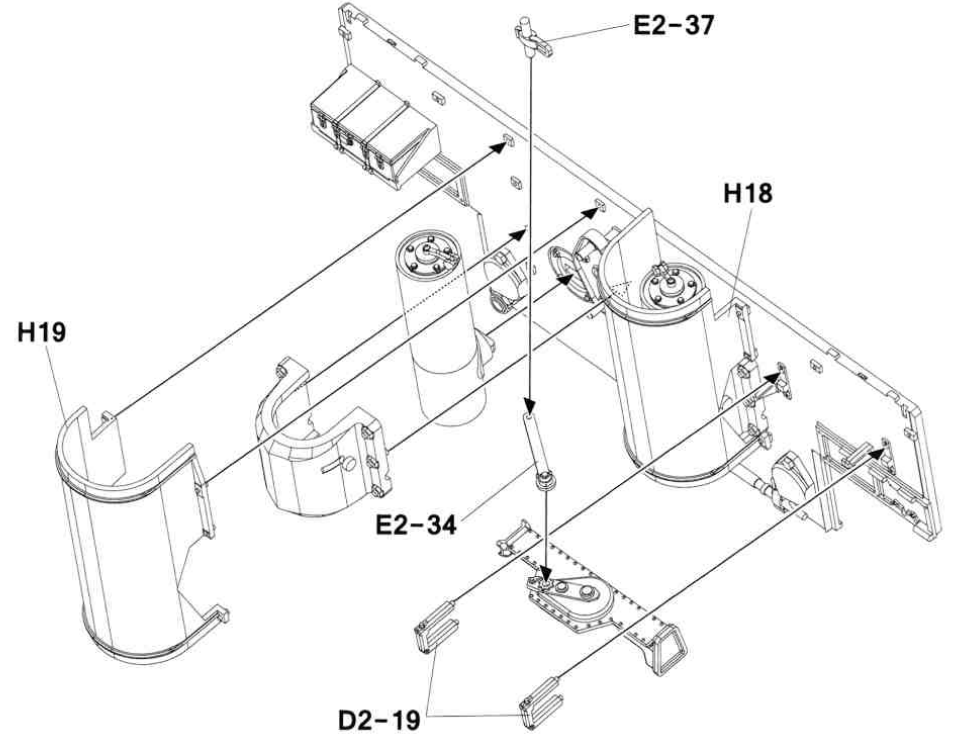
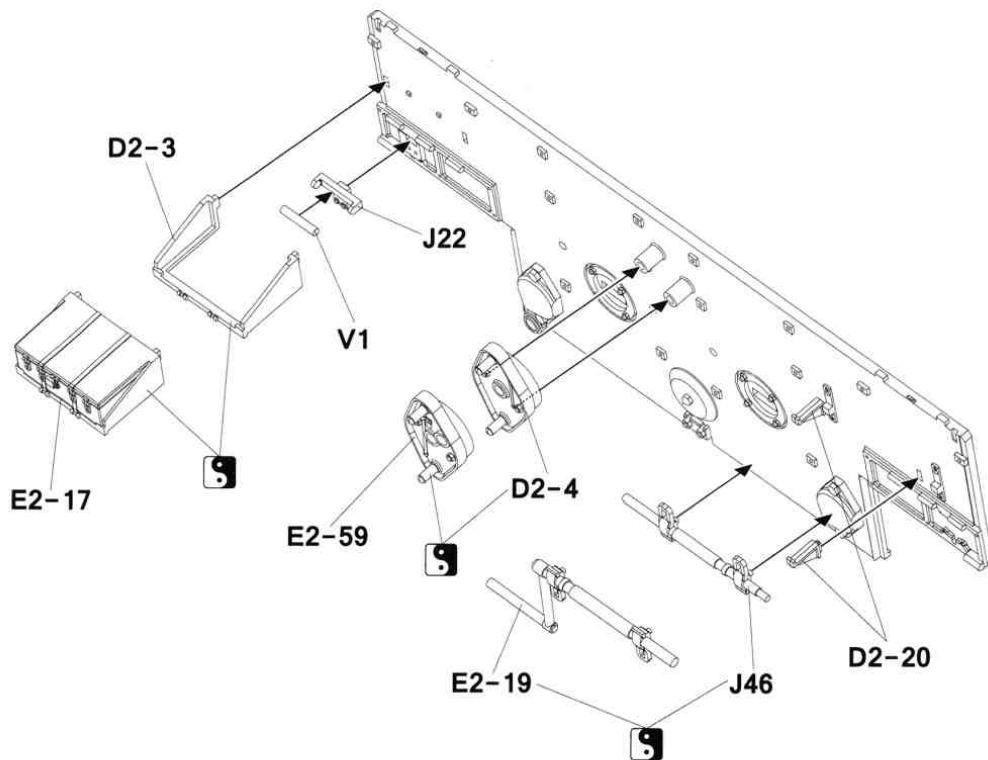
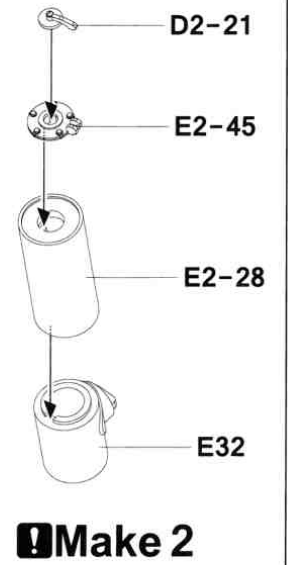
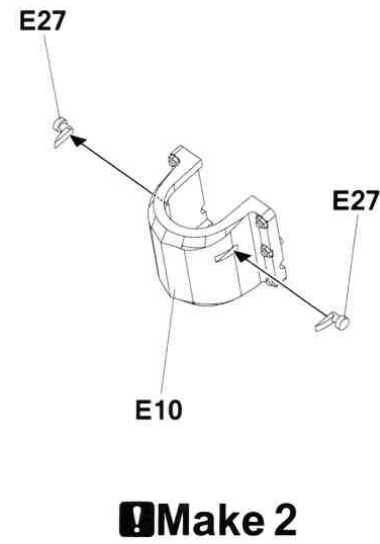
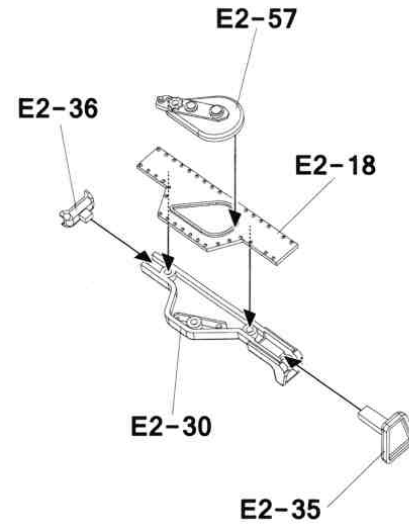
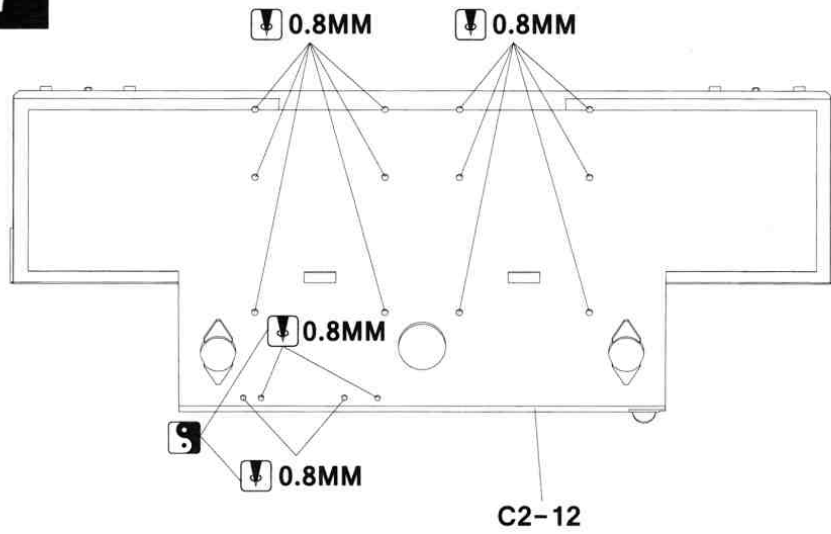

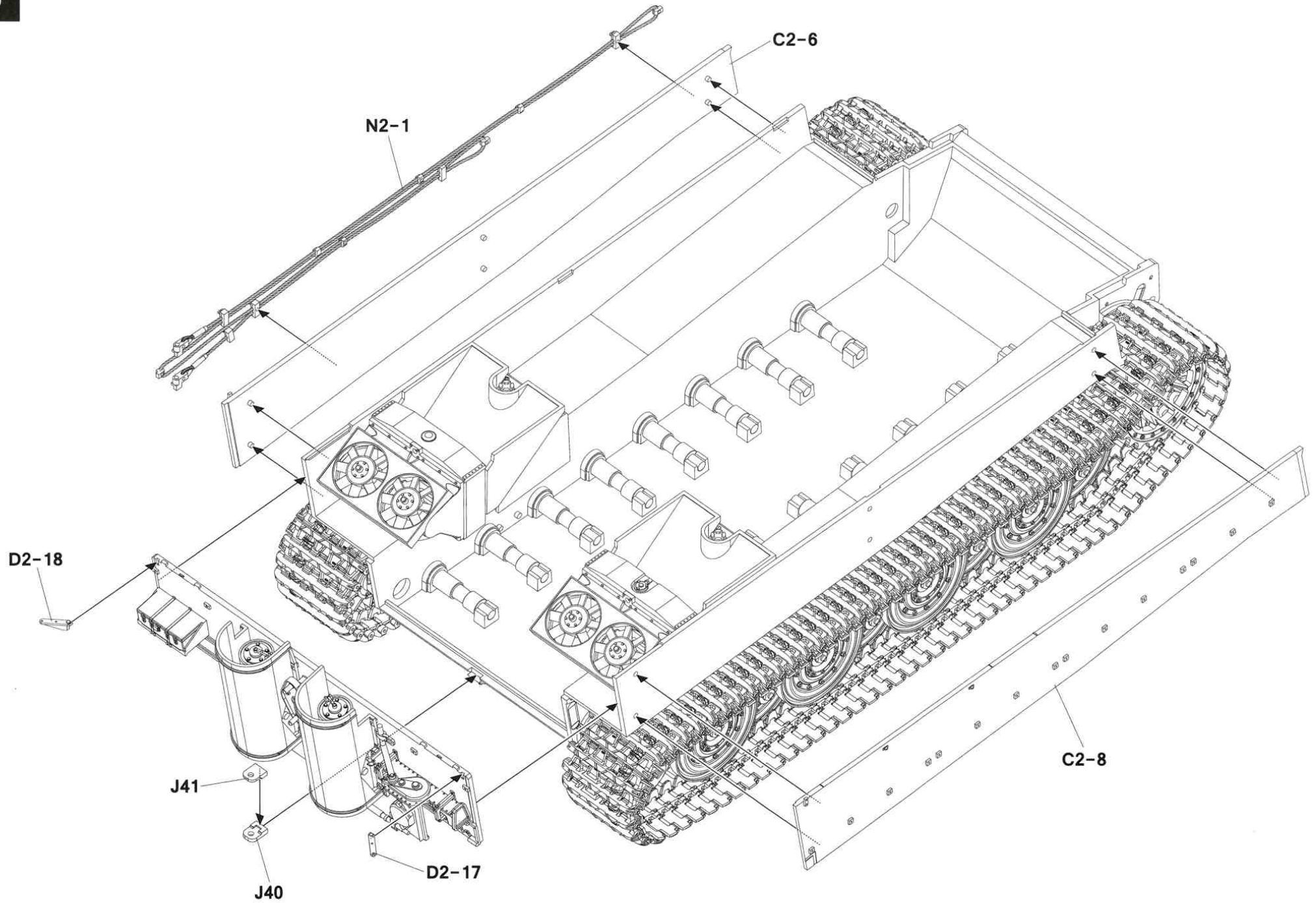

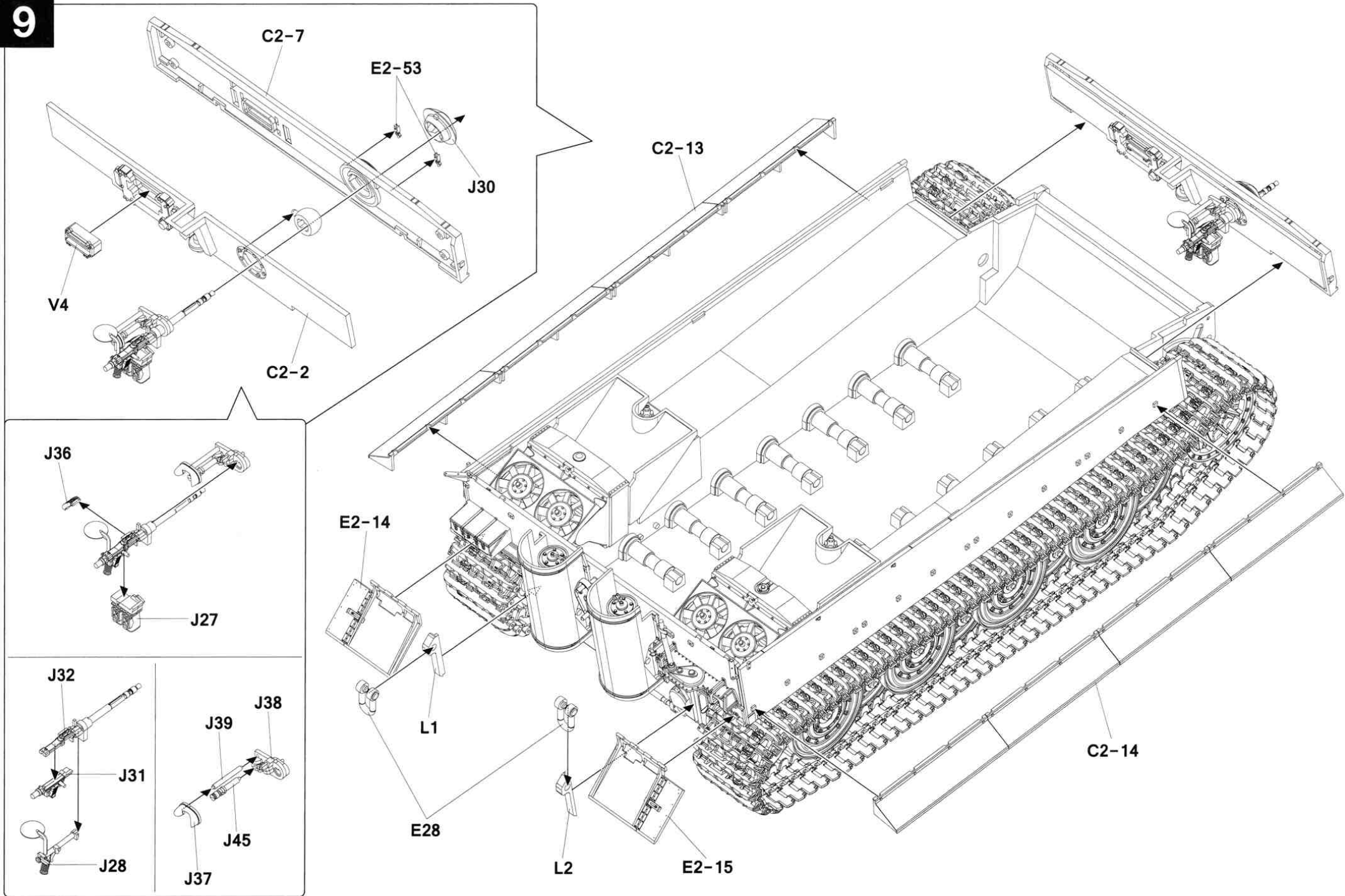

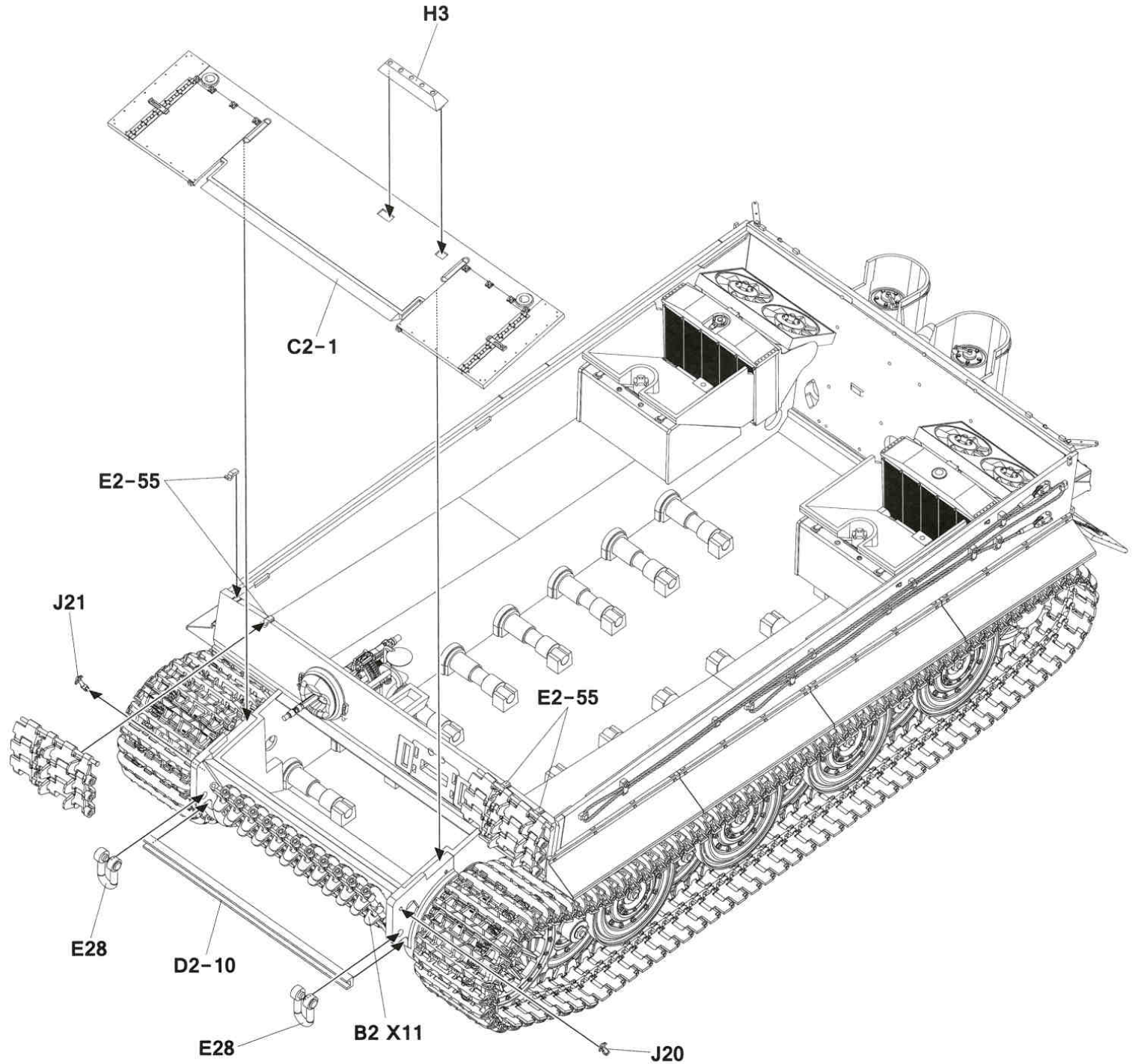
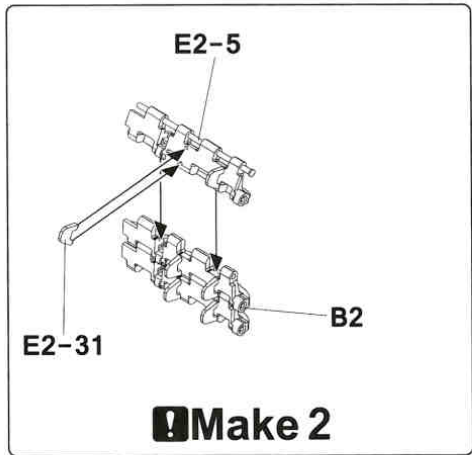

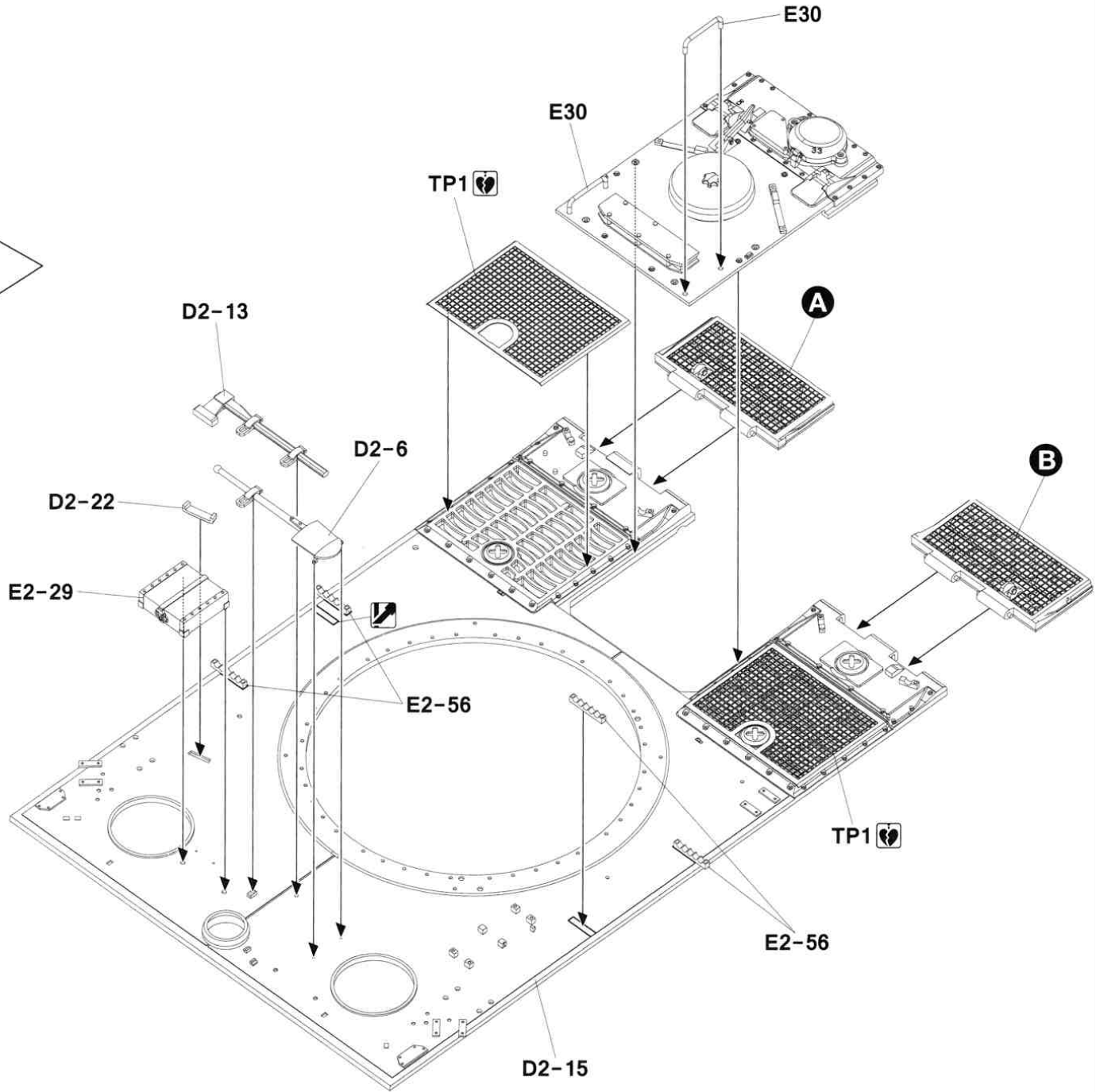
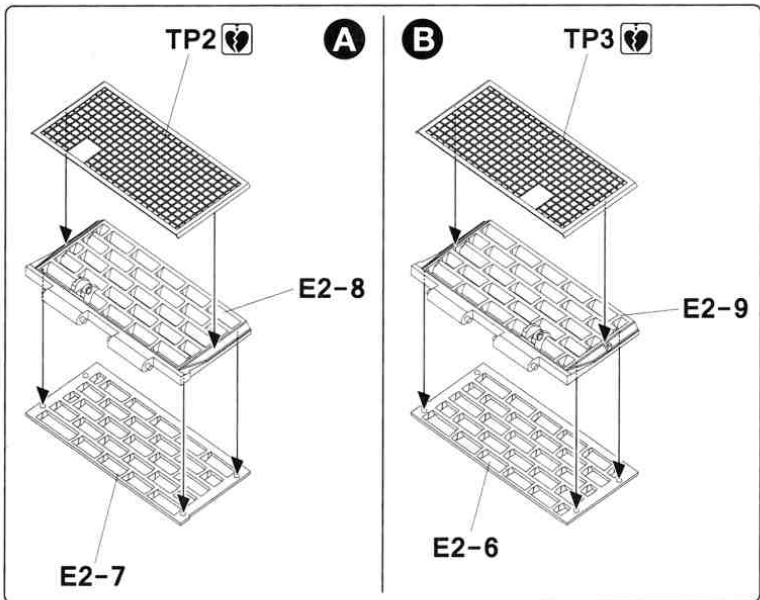
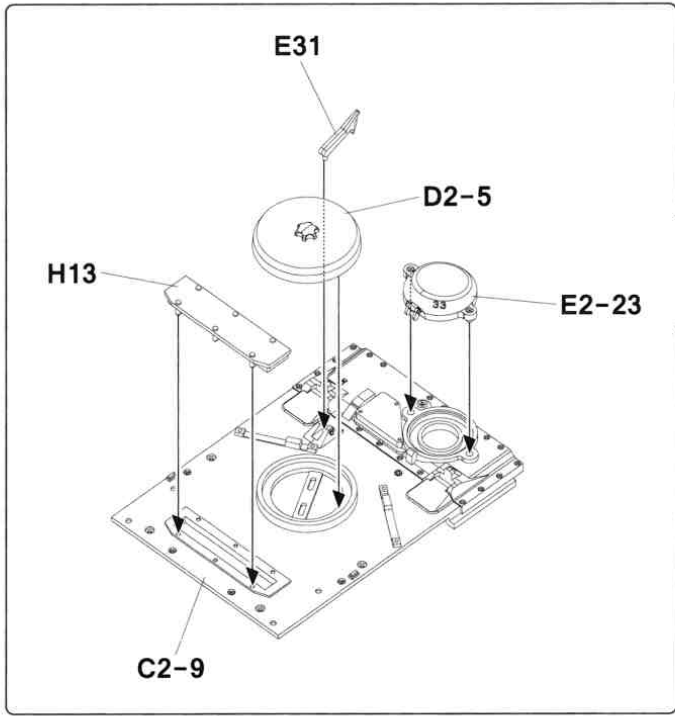

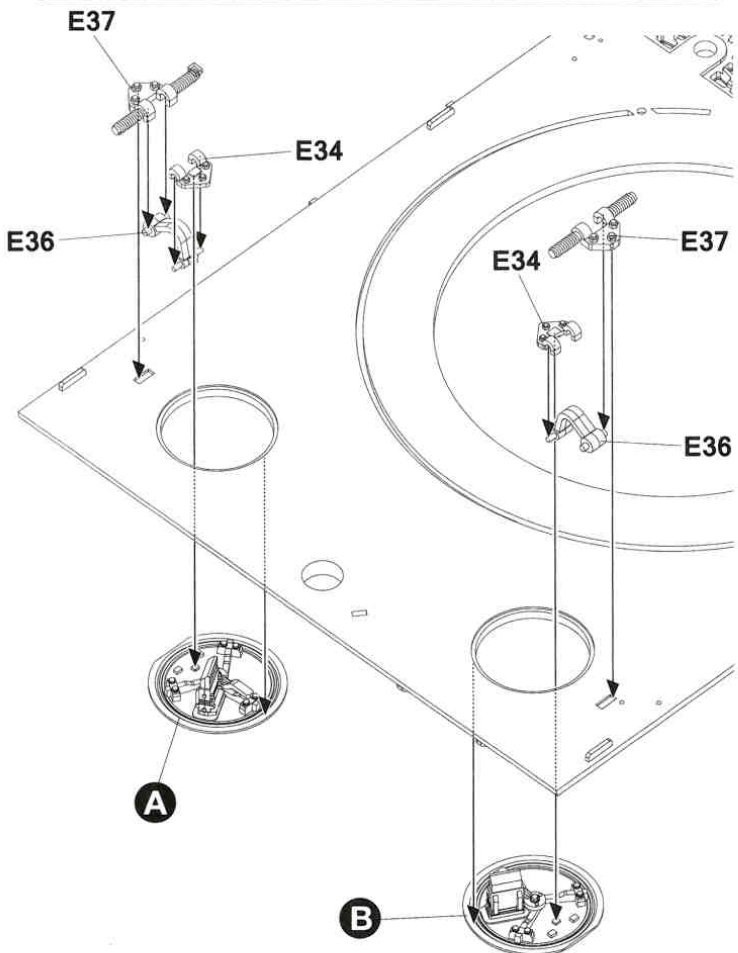
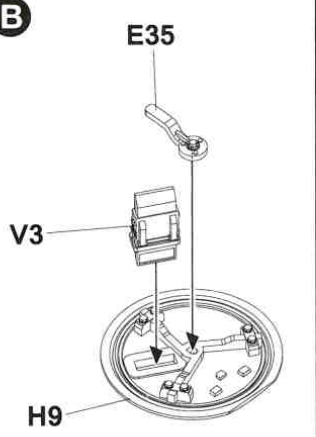
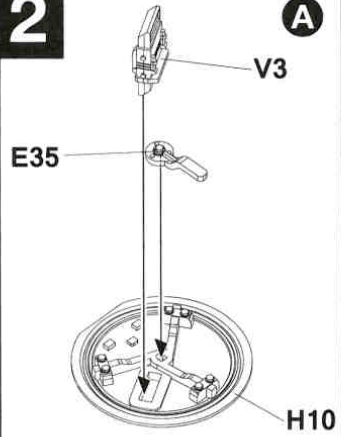
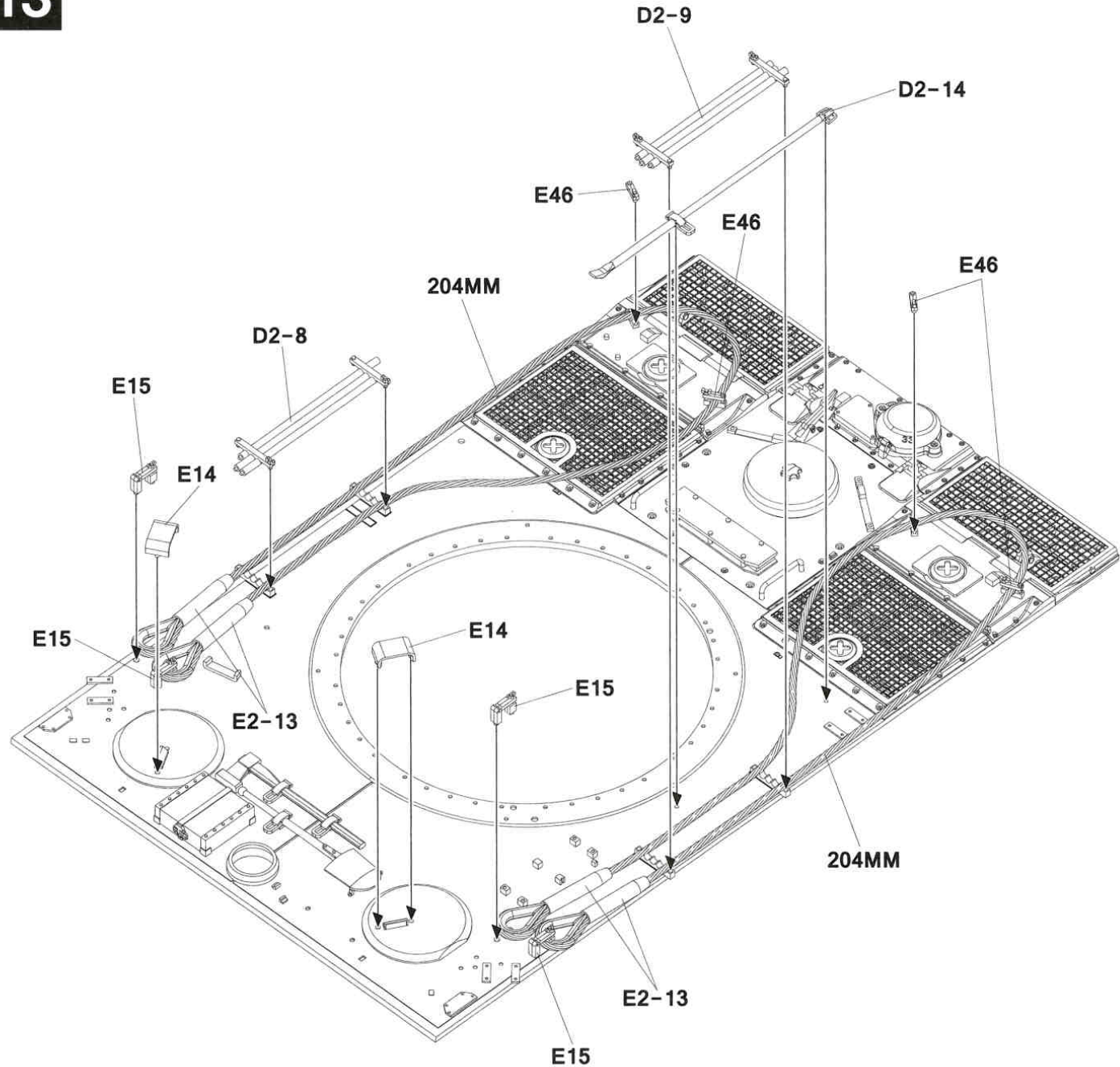
12**A****B****13**

14

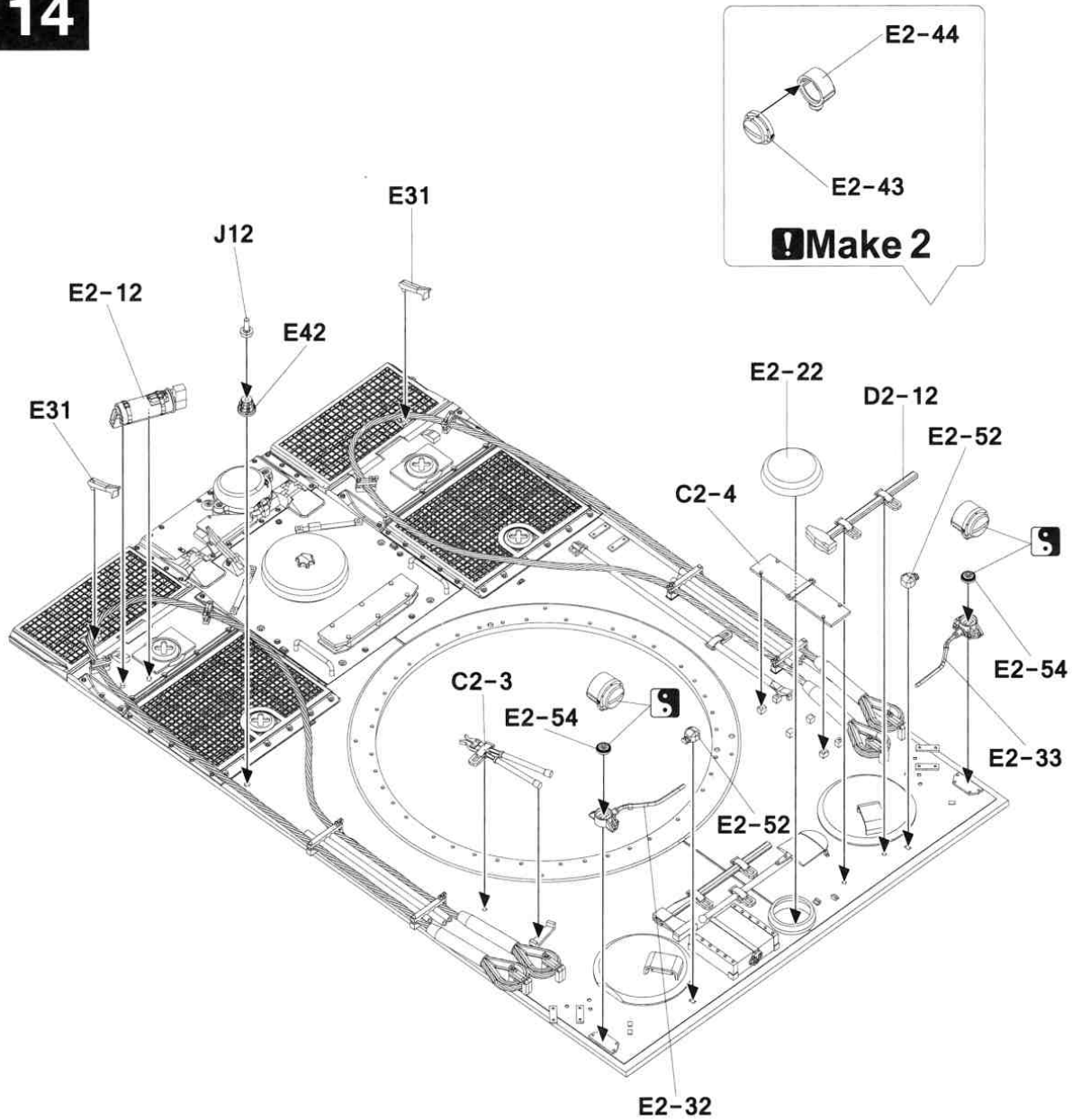

15

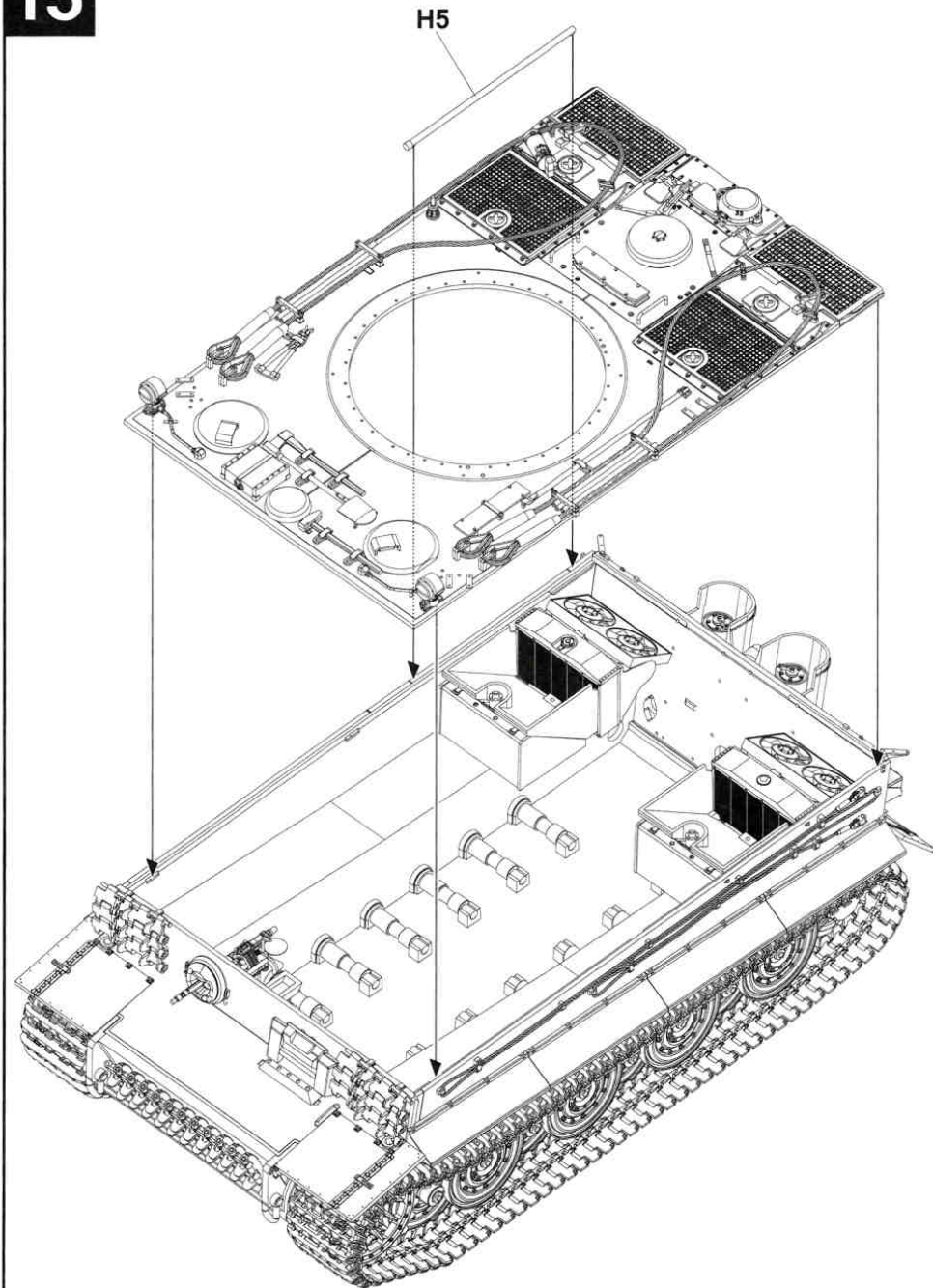

16

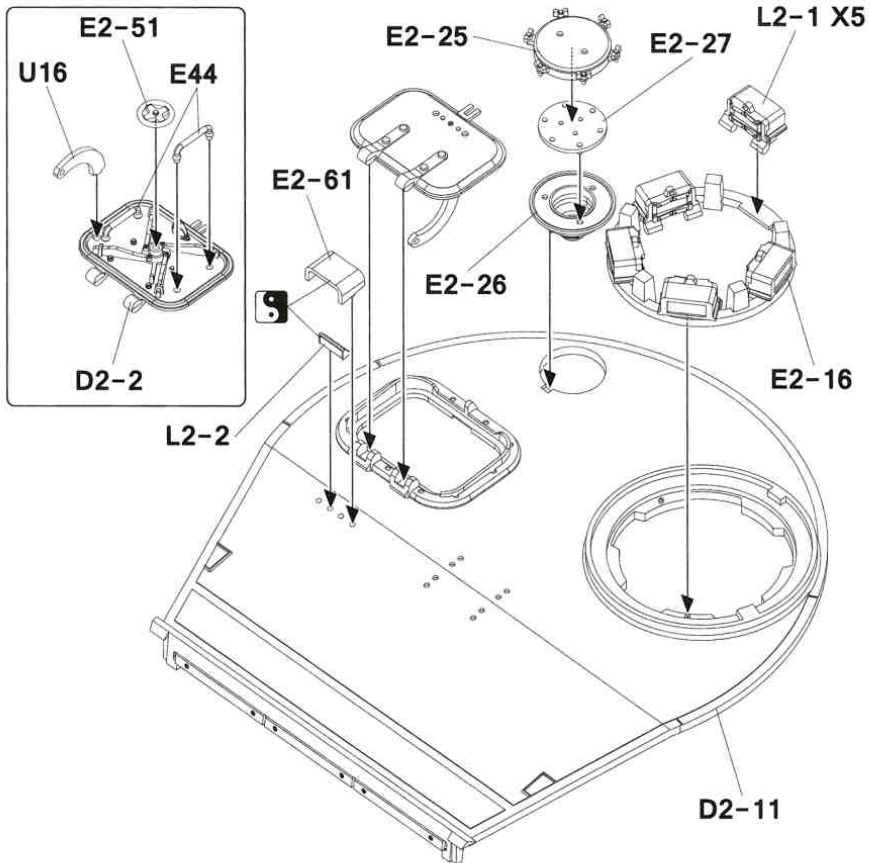
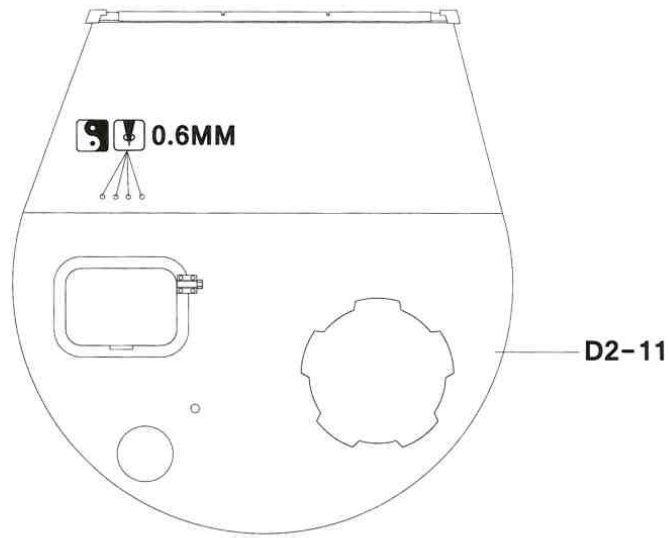

17

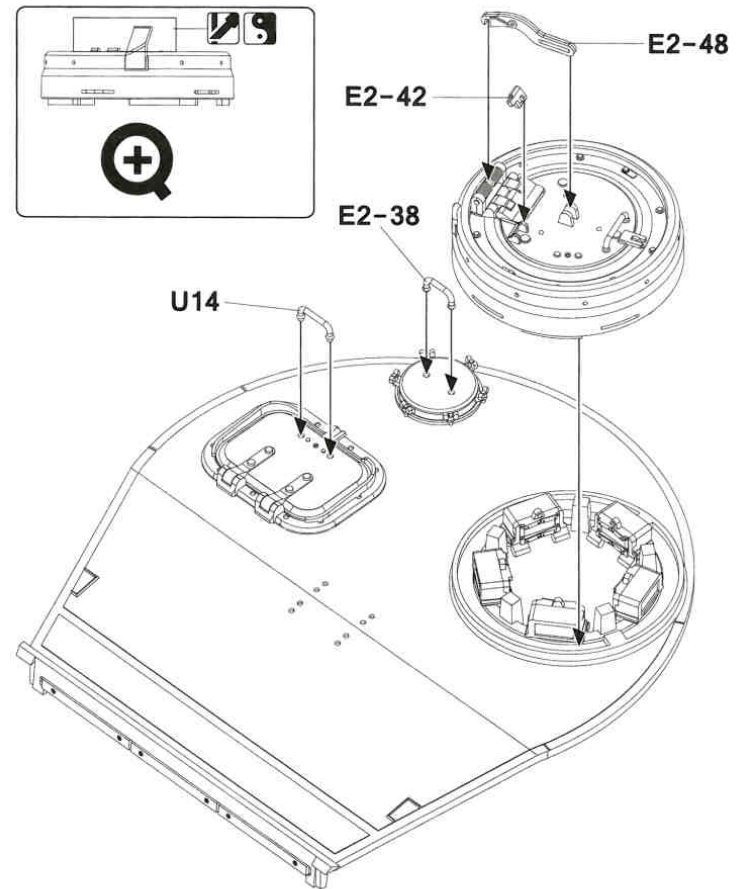
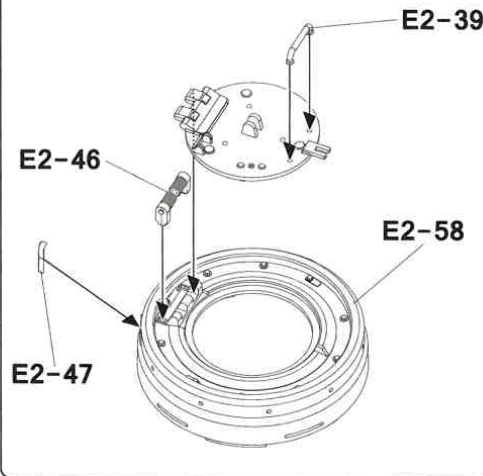
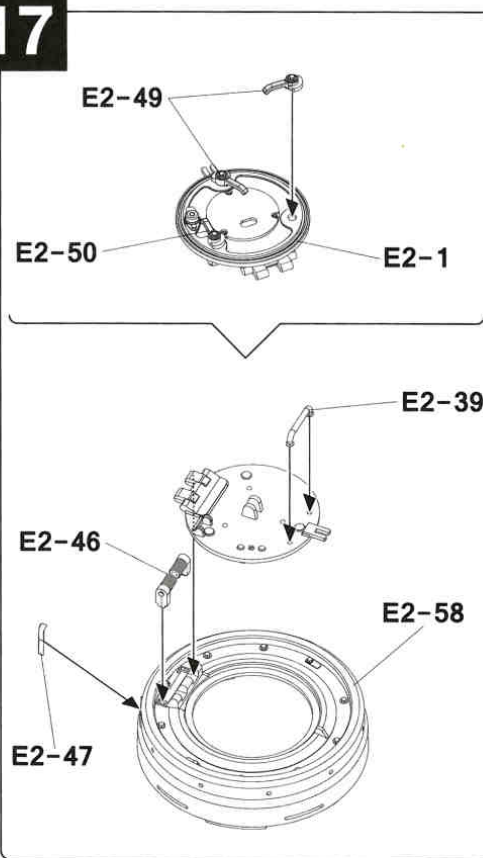

18

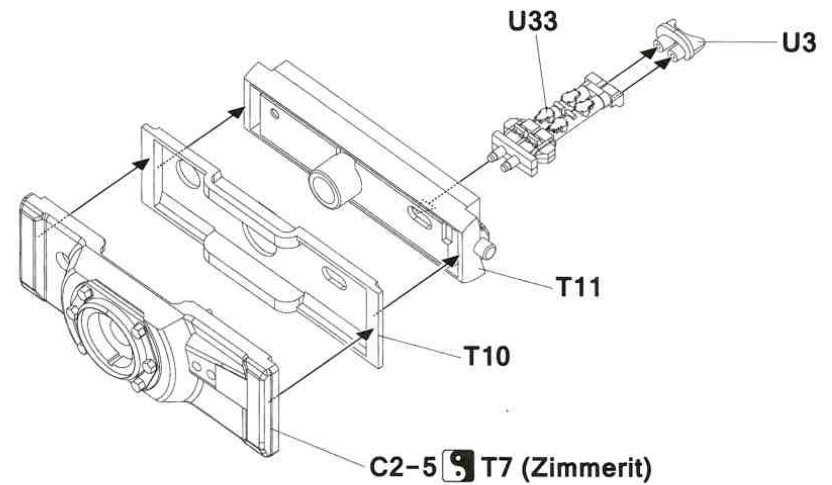

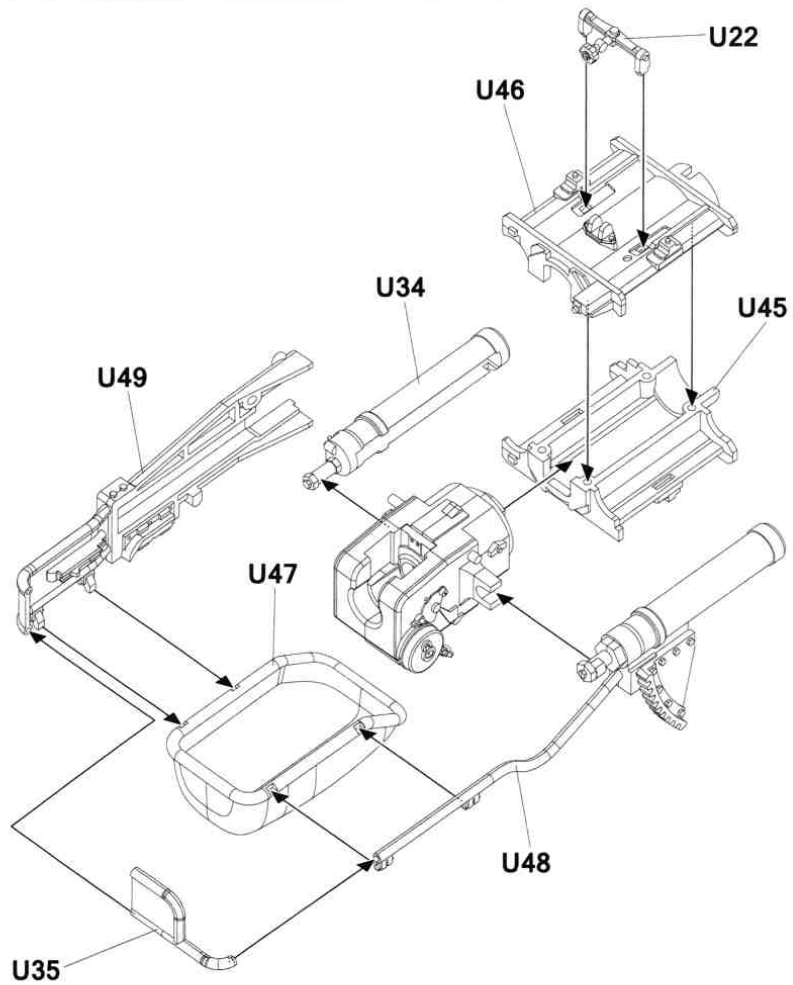
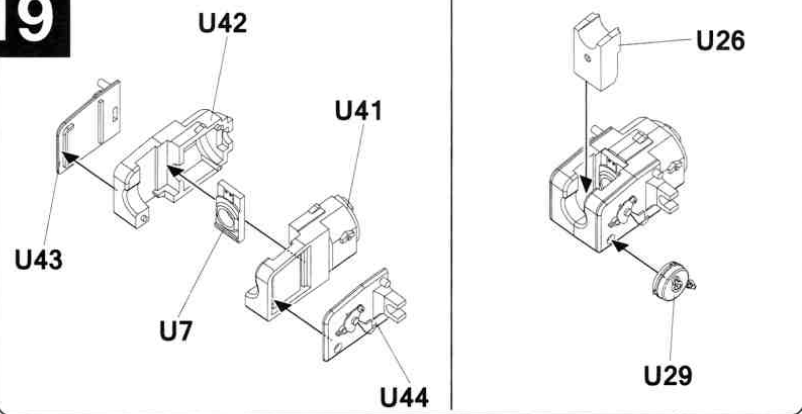
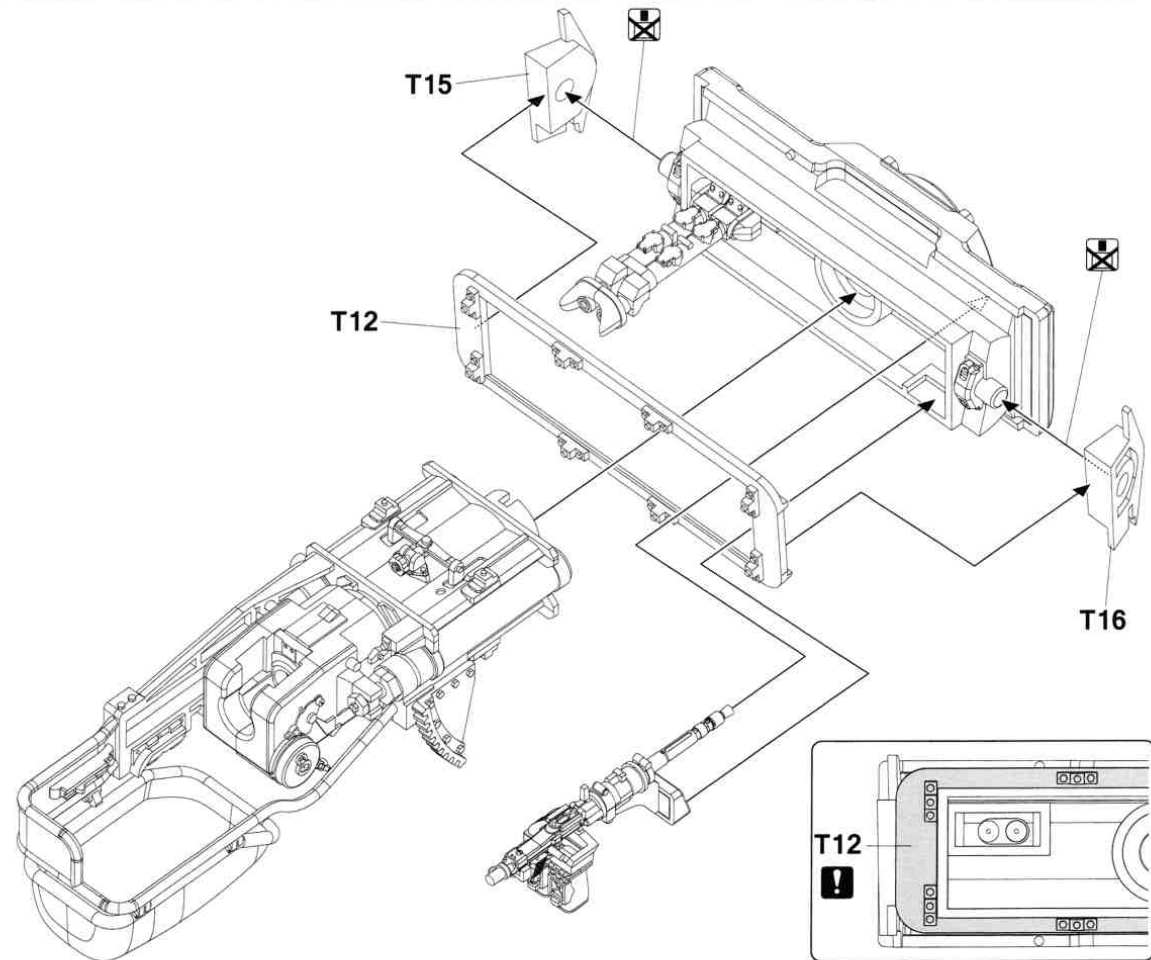
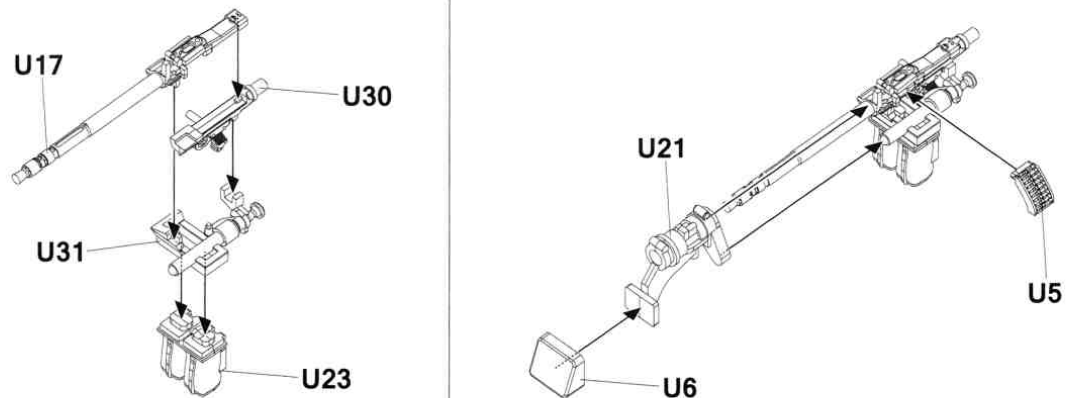
19**20****16**

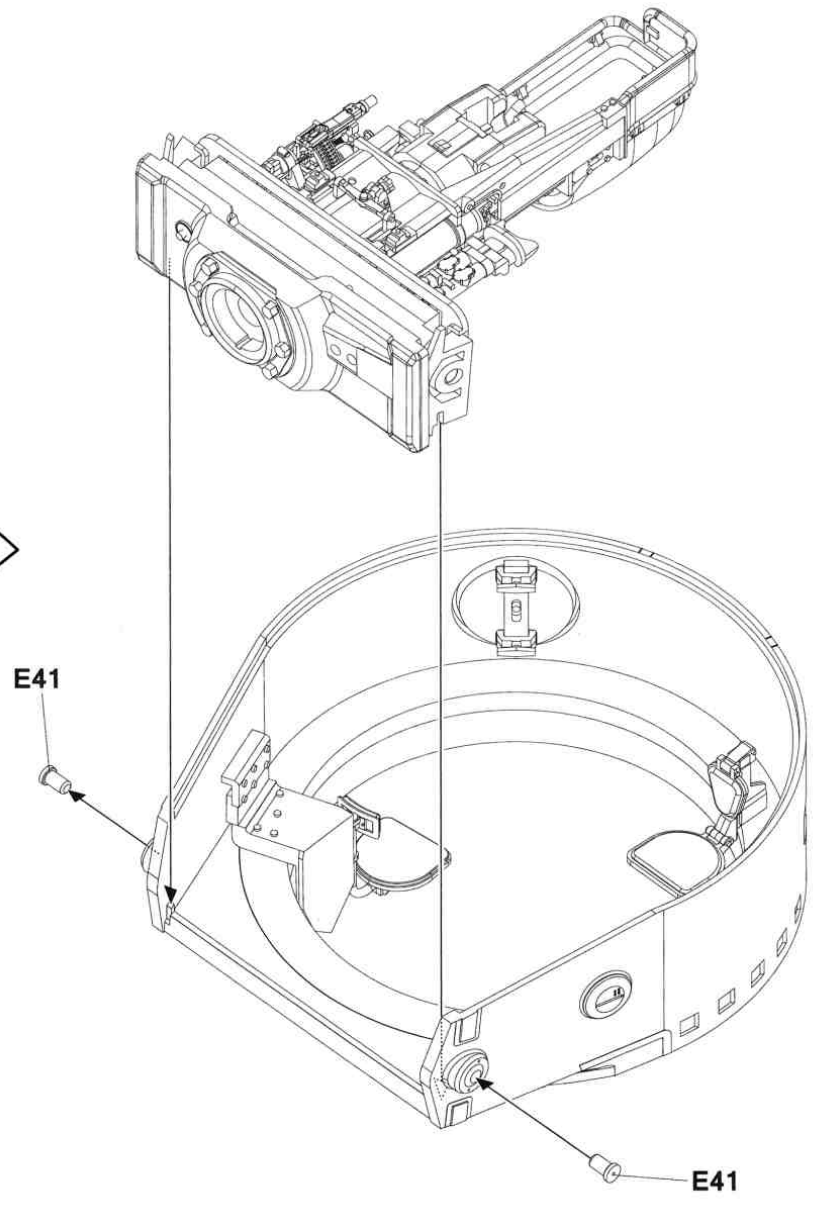
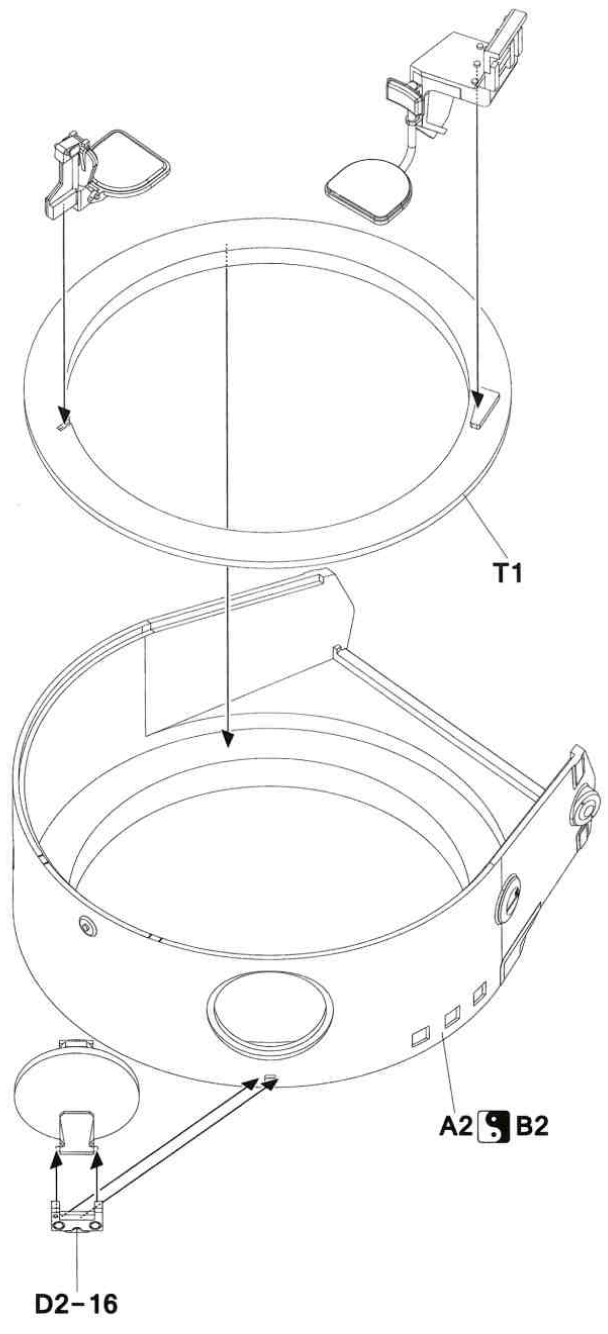
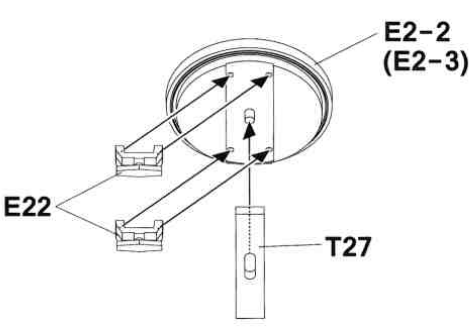
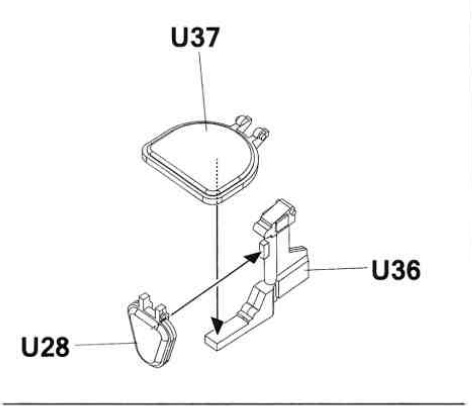
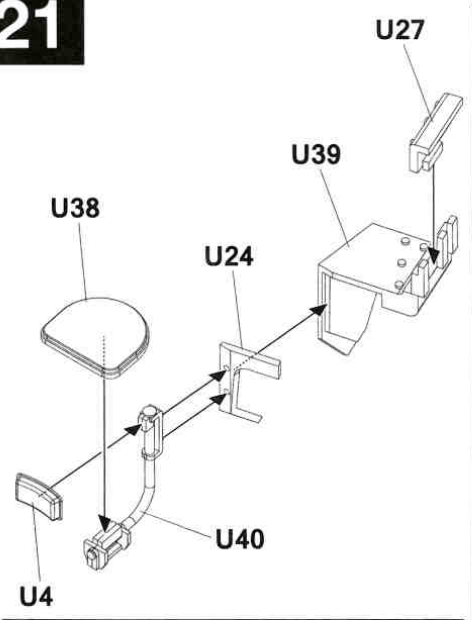

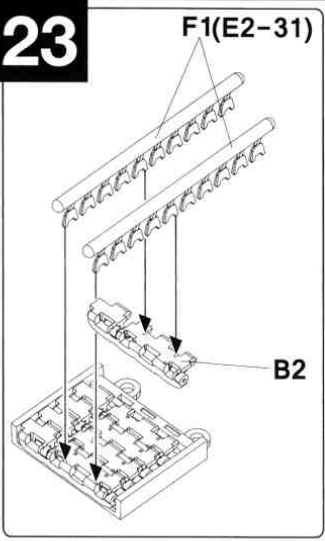
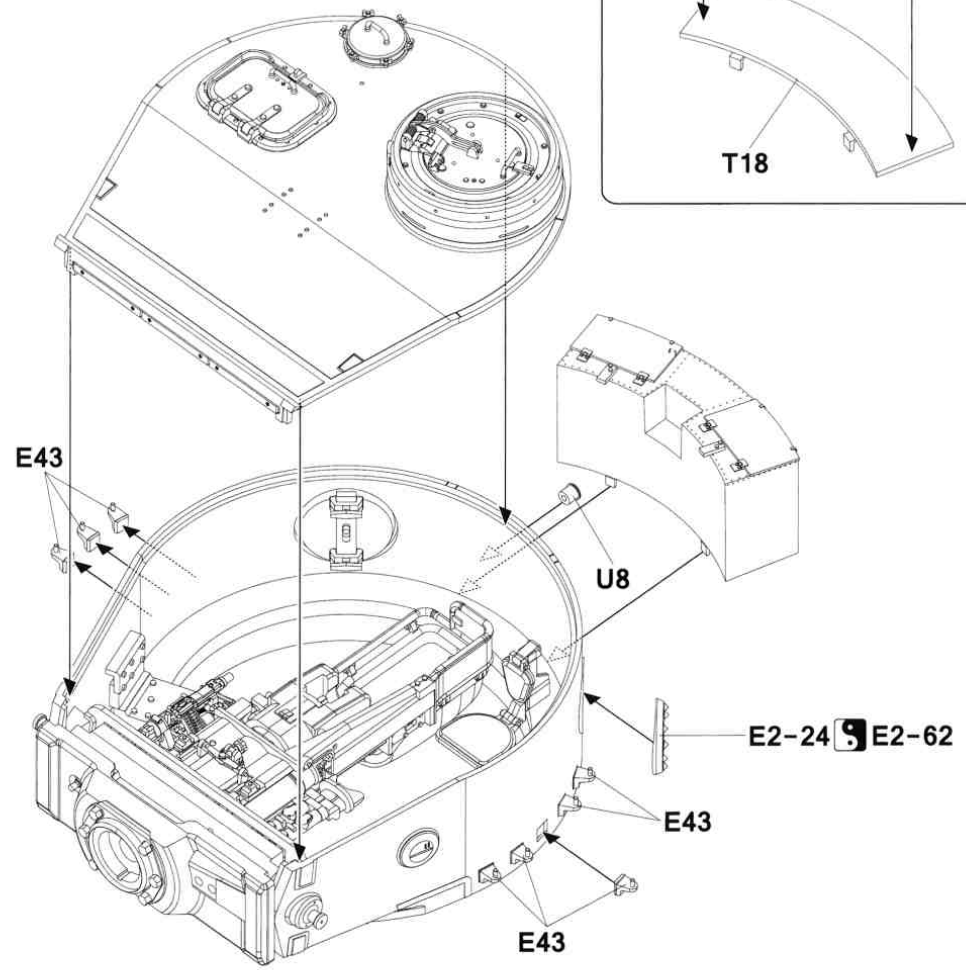
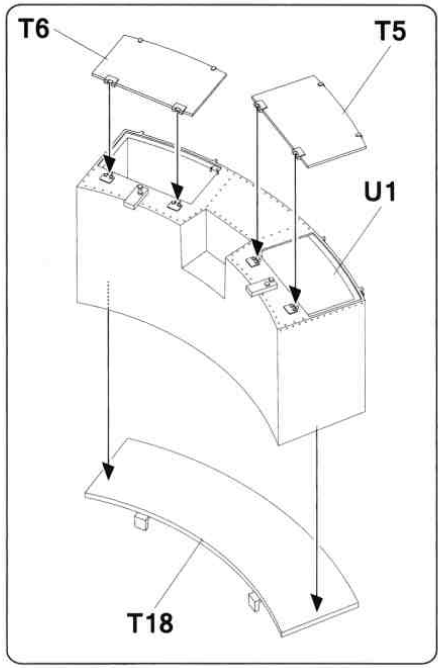

T19

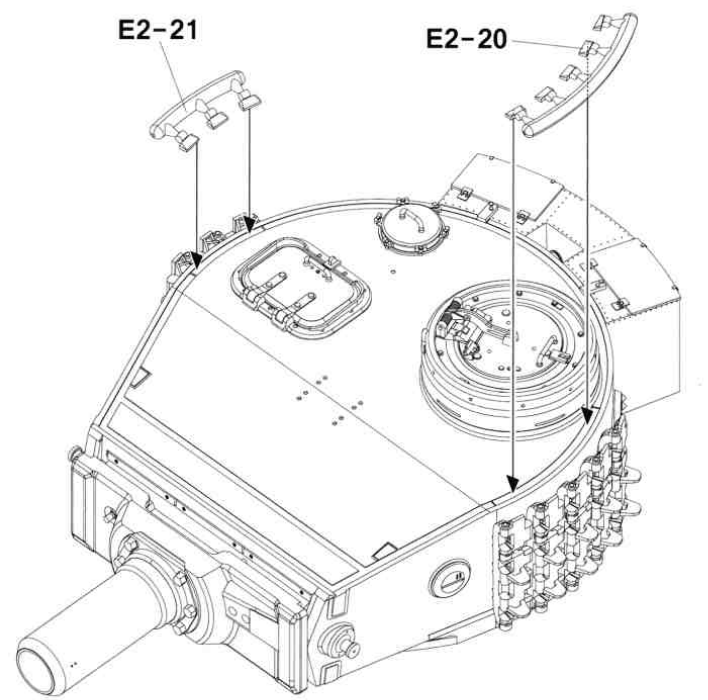
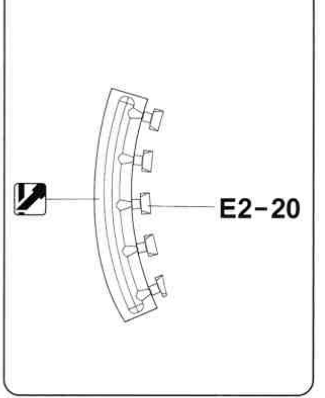
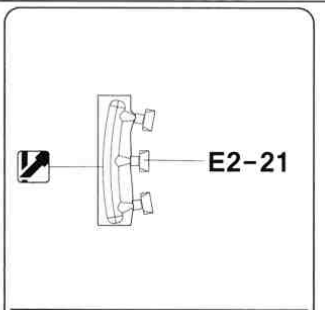
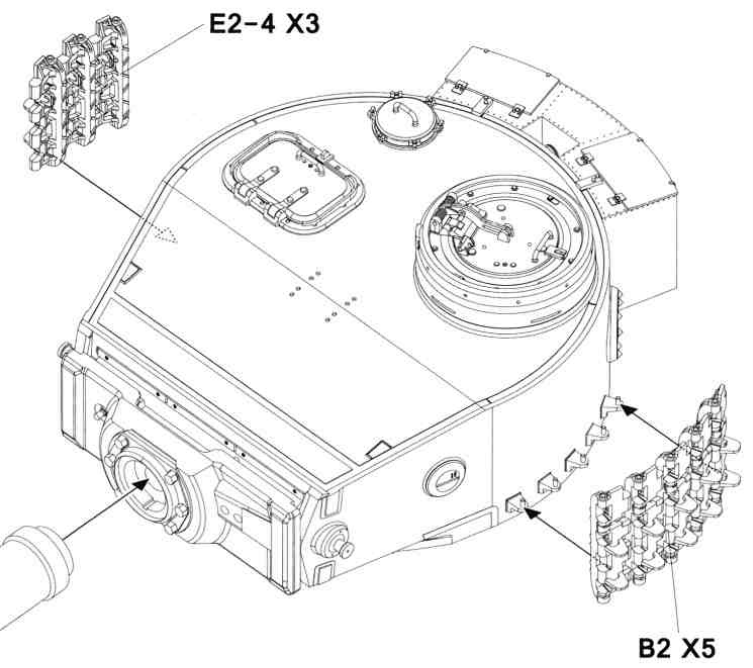

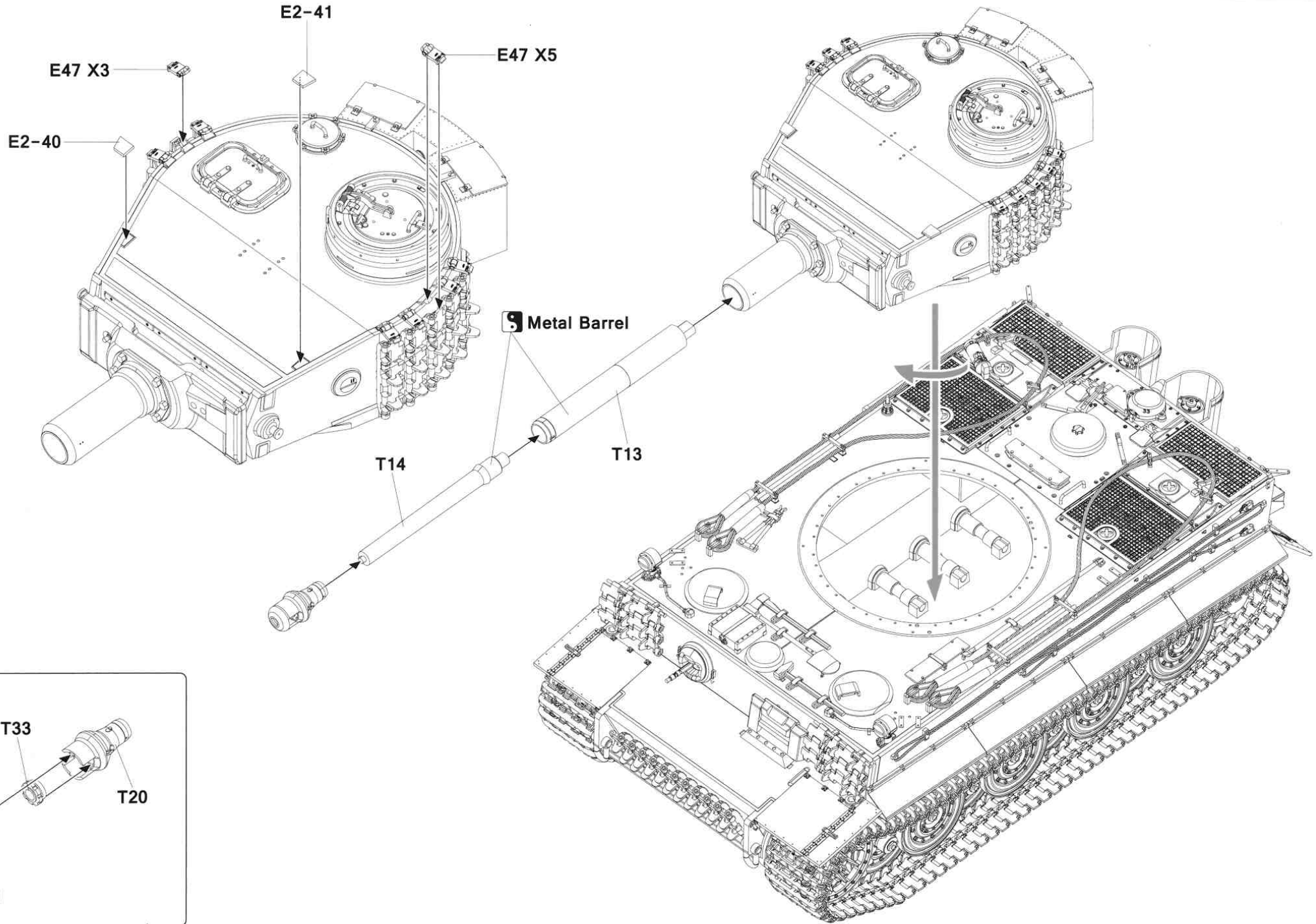

TIGER I

EARLY-PRODUCTION MODEL WITH
STEEL WHEELS
w/Zimmerit

Painting and Marking Guide

TAKOM №: 2202

Gruppe Febrmann, Germany, Spring 1945

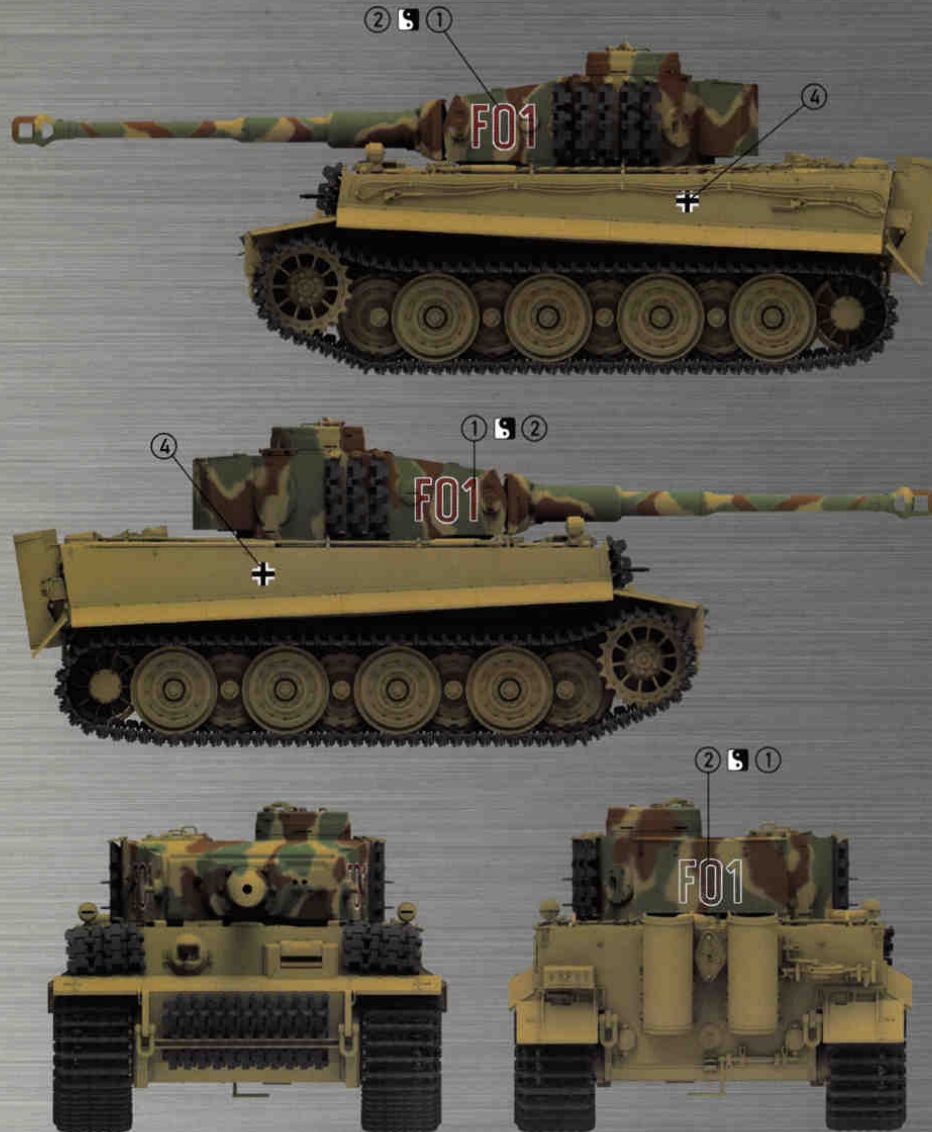

TIGER I

EARLY-PRODUCTION MODEL WITH
STEEL WHEELS
w/Zimmerit

Painting and Marking Guide

TAKOM №: 2202

schwere Panzer Kompanie Hummel, schwere
Panzerabteilung 506, Ardennes, France 1945



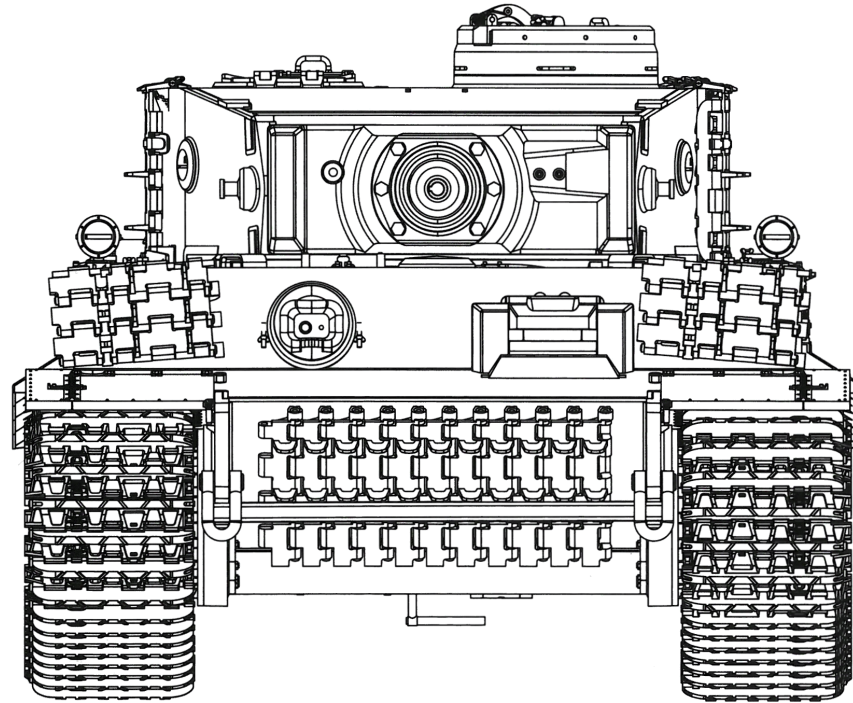

You can find TAKOM on Facebook.com