

TIRAN 4 EARLY TYPE

37010



GENERAL INSTRUCTION

■ HIGHLY DETAILED MODEL

- WORKABLE TORSION BARS
- V-54 ENGINE INCLUDED
- FULLY DETAILED FIGHTING COMPARTMENT INTERIOR
- DRIVER COMPARTMENT INTERIOR ACCURATELY REPRESENTED
- ALL HATCHES CAN BE POSED OPEN & CLOSED
- DECAL SHEET FOR 3 VARIANTS

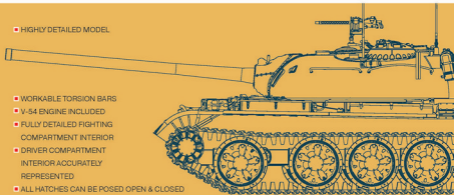

PAINTING GUIDE
ОКРАСКА

IDF, 1972-1974 years. The last three digits of the serial number of the tank, not identified!

Армия Обороны Израиля, 1972-1974 годы.

Последние три цифры серийного номера танка не идентифицированы!



IDF, 1972-1974 years. The last three digits of the serial number of the tank, not identified!

Армия Оборона Израиля, 1972-1974 годы.

Последние три цифры серийного номера танка не идентифицированы!

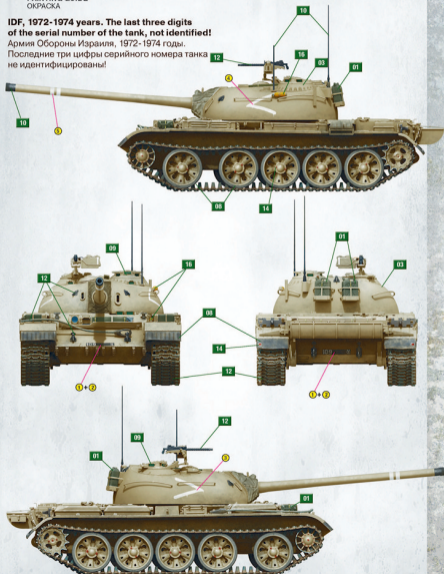

PAINTING GUIDE ОКРАСКА

IDF, 1970-1973 years. The last three digits of the serial number of the tank, not identified!

Армия Обороны Израиля, 1970-1973 годы.

Последние три цифры серийного номера танка не идентифицированы!



Colors Chart

№	Color Name	Value	R	G	B	Color Name	Value	R	G	B	Color Name	Value	R	G	B	Color Name	Value	R	G	B
01	Green Olive	10	64	75	39	194	80	95	50	85	Black	000	0	0	0	Black	000	0	0	0
02	Brown	20	64	32	24	120	50	20	100	20	Dark Red	100	100	0	100	100	0	0	0	
03	Yellow	30	100	100	0	100	100	0	100	0	Dark Blue	0	0	100	0	0	0	0	0	
04	White	40	100	100	100	100	100	100	100	100	Dark Green	0	100	0	0	0	0	0	0	
05	Red	50	100	0	0	100	0	0	100	0	Light Green	0	100	100	0	0	0	0	0	
06	Blue	60	0	0	100	0	0	100	0	0	Light Blue	0	100	100	0	0	0	0	0	
07	Orange	70	100	50	0	100	50	0	100	0	Dark Blue	0	0	100	0	0	0	0	0	
08	Grey	80	100	100	100	100	100	100	100	100	Dark Green	0	100	0	0	0	0	0	0	
09	Light Green	90	100	100	0	100	100	0	100	0	Dark Blue	0	0	100	0	0	0	0	0	
10	Dark Green	100	0	100	0	100	0	100	0	0	Dark Green	0	100	0	0	0	0	0	0	
11	Light Blue	110	0	100	100	0	100	100	0	0	Dark Green	0	100	0	0	0	0	0	0	
12	Dark Blue	120	0	0	100	0	0	100	0	0	Dark Green	0	100	0	0	0	0	0	0	
13	Light Green	130	0	100	0	100	0	100	0	0	Dark Green	0	100	0	0	0	0	0	0	
14	Dark Green	140	0	100	0	100	0	100	0	0	Dark Green	0	100	0	0	0	0	0	0	

Таблица цветов

ATTENTION

Ne pas utiliser de colle ou de peinture à proximité d'une flamme nue, et aérer la pièce de temps en temps.
 Pour retirer les pièces hors du cadre, utiliser des ciseaux spéciaux pour découper la plastique en écarts avec un cutter ou une lime.
 Vor la fin de cette colonne pour la signification des symboles.
 Après l'assemblage peut rester des pièces inutilisées.

ZUR BEACHTUNG

Heißer und feuchter Luft nicht nahe von offenem Feuer verwenden und die Fenster von Zeit zu Zeit zur Belüftung öffnen.
 Zum Abschneiden der Teile vom Verbundstück eine Modellierschere verwenden und die Überstehenden Plastikteile mit einem Messer oder einer Feile beseitigen.
 Die Bedeutung der Symbole finden Sie unten in dieser Spalte.
 Nach dem Zusammenbau des Modells, können einzelne Teile übrig bleiben.

УВАГА

При використанні клею та фарби проводити роботу відкритим вікном у приміщенні, що добре провітрюється.
 Деталі відокремлювати від лишків ножицями або іншим ручним інструментом. Застерегти обробку місця зрізу за допомогою надфайлу та надфайлової паперу. Букування моделей виконувати згідно зі схемою. Для зручності побудови кожна деталь позначена номером.
 Після складання можуть залишитися невикористані деталі.

ATTENZIONE

Non usare colla o vernice vicino a fiamme scoperte, e aprire le finestre di tanto in tanto per cambiare l'aria. Quando si staccano parti del modello, usare forbici da modellismo o eliminare la plastica in eccesso con un coltello o una lima. Vedere in fondo a questa colonna per il signifi-
 Dopo l'assemblaggio possono rimanere parti inutilizzate.

ВНИМАНИЕ

При использовании клея и красок всю работу проводить в проветриваемом помещении вдали от источников огня.
 Детали отделять от лишков ножом или другим ручными инструментами. Застерегти обробку місця зрізу при появленні надфайлу та надфайлової паперу. Обробку моделей проводити згідно зі схемою.
 Для зручності побудови кожна деталь позначена номером.
 Після обробки набору можуть залишитися невикористані деталі.

CAUTION

When you use glue or paint, do not use near open flame, and use in well-ventilated room. When you take parts off from the runner frame, use modeling scissors or cutter.
 See the bottom of this column for the meaning of symbols.
 Extra details can remain after assembling of the kit.

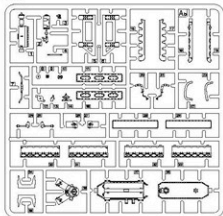
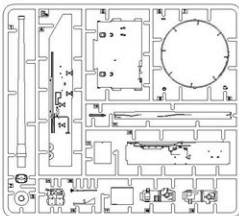
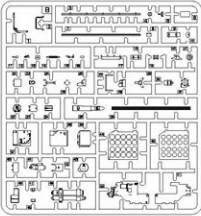
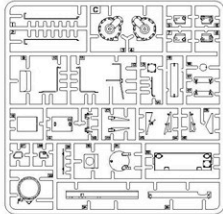
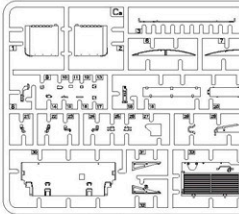
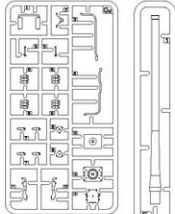
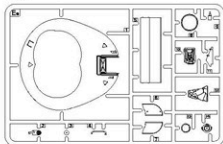
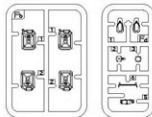
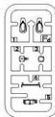
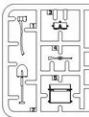
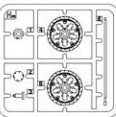
PARTS/ДЕТАЛИ**Ab****Ba****B****C****Ca****Gd****Fa****Ea****Fb x2****Fd x2****Fc****Hm x10****Decal/Деколь****Tiran 4 Early Type. Interior Kit 37010**

1 109

1 2 3 4 5 6 7 8 9 0 2 1 2 3 4 5 6 7 8 9 0

1 109

1 2 3 4 5 6 7 8 9 0 2 1 2 3 4 5 6 7 8 9 0

3

5

4

6

3

7

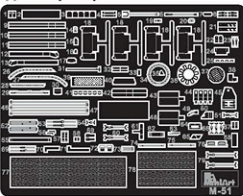
**Photo-etched parts. PE (M-51)
Детали фототравления**



MAKÉ ZEM
2 TEBÉ FÉRTŐZÉS
ÉRTÉKELÉSI TEBÉZ
FARE GLE PEZZE
TELE TEBÉZ
GÖR 2 ST
ГЛАВНОУ ДІЯ ПАРА
КОЛІСТЬ ПІСВ



DO NOT CEMENT
NIGHT ALEREN
NE PAS COLLER
NON INCOLLARE
ESLAMA
LIMBAŞI
ГЛАВНОУ ДІЯ ПАРА
КОЛІСТЬ ПІСВ



OPTIONAL
NACH BELIEBEN
FACILITATIVO
FACILITATIVO
VALIKORVAHANGON
VALIKORVAHANGON
BAKUPHAT
BAKUPHAT



OPEN HOLE
PARE IN TROU
FORO APERTO
ANZA BUCHE
OPNA HAJET
ODKRYVA OTVORNYE
SPROSTNY OTVOR



REMOVE
ENTFERNEN
REINIGEN
SEPARARE
PULSARE
ALAGNATI
OTKRYVA
BUPHATY



BEHO
SITTE BEGREN
PLUMER VOUR PLANT
FIGURARE
SOLA
BOCCA
BUPHATY
BUPHATY



BOVATZIGELD
AM MUEBLEN ZU MACHEN
FAIRE LE PLUS
BENEFITI
TELE FINE
GÖR DİG BULU
GÖR DİG BULU
SPROSTNY GARDNY
SPROSTNY GARDNY

INSTRUCTION/ИНСТРУКЦИЯ

D

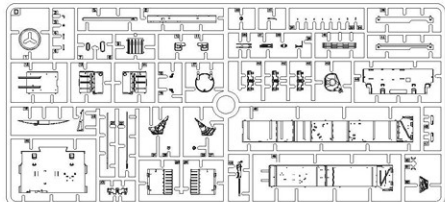

Ma

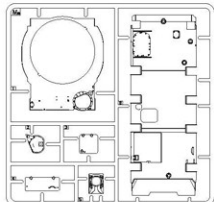

G

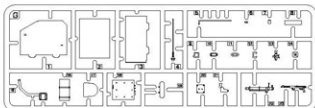

Ge

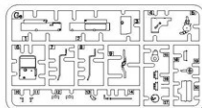

Ff x3

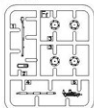

Ga



Hb

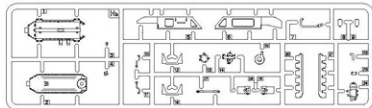

Gf

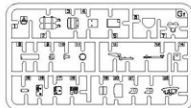

Na

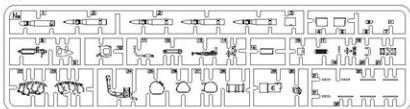

H x5



Hd x4



La



Fe

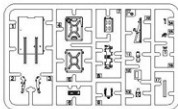

Hg x10

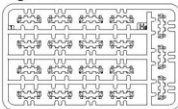

Ho x4

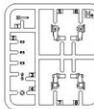

Hn x3

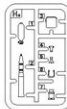

Jb

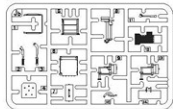

Ke x2

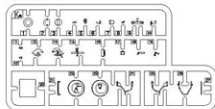

Kd x2

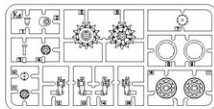



MADE FROM
2 TEILE FÜR DIESEN
EFFEKTLICHEN TIEFEN
FARE DUE PEZZI
TEC. NICK
ODR 2 ST.
PODOBNOU DVA DILA
KOLICHOVA PEZEV



DO NOT CEMENT
NICHT KLEBEN
NE PAS COLLER
NON BOLLARRE
EKLIMAS
LIMANUJ
НЕ ИСПОЛЗОВАТЬ КЛЕЙ
НЕ КЛЕИТЬ



OPTIONAL
NACH BELIEBEN
FACULTATIV
FACOLTATIVO
VOLUKOMNENNO
VALUJAV
ВЫПРАВИТЬ
ВАРИАНТ



OPEN HOLE
OFFENEN
PANEL EN TROU
FORO APERTO
AOLIA NECA
OPNA PALET
СДЕЛАТЬ ОТВЕРСТИЕ
ВПРОТЯГ ОТВЕР



REMOVE
ENTFERNEN
RETRIER
SOTIRARE
ROTA
AVALGIRVA
OTVORIT
BERGHAUT



BEND
BITTE BEUGEN
PLIERER, YOUR PLANT
PLEGARE
TATA
RODCA
ВЫГНУТЬ
ВИНУТИ



SOBATHUILD
AM BESTEN ZU MACHEN
FAIRE LE PLUS
REAGATI
TELE TEE
ODR DIO BALEV
СДЕЛАТЬ ГАМБУС
ВПРОТЯГ ГАМБУС



PARTS NOT FOR USE
TEILE WERDEN NICHT VERWENDET
NIET PAS OTLEGE
PARTI NON FARE L'USO
ODSA SO KAVTA
INTE FOR ANVÄNINGEN
НЕ ИСПОЛЗОВАТЬ
НЕ ИСПОЛЗОВАТЬСЯ

INSTRUCTION/ИНСТРУКЦИЯ

Ld



Ta x2

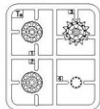

Ka

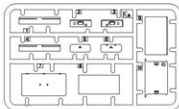

Pc

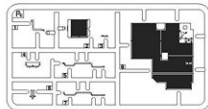

Q

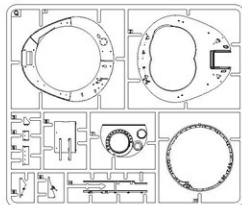

R

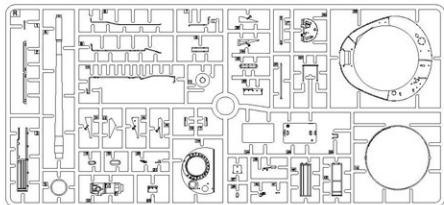

CLEAR PARTS / ПРОЗРАЧНЫЕ ДЕТАЛИ

Jc

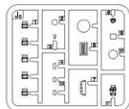

Je



S

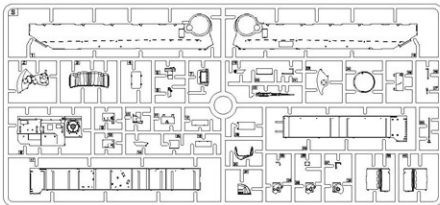

Pb

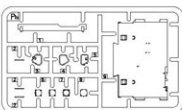

Te

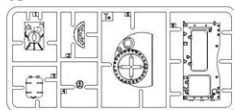

Tb

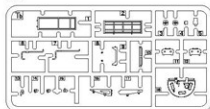

T x2

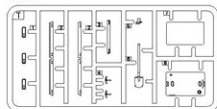

Tc x3

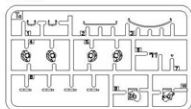

Fg x2



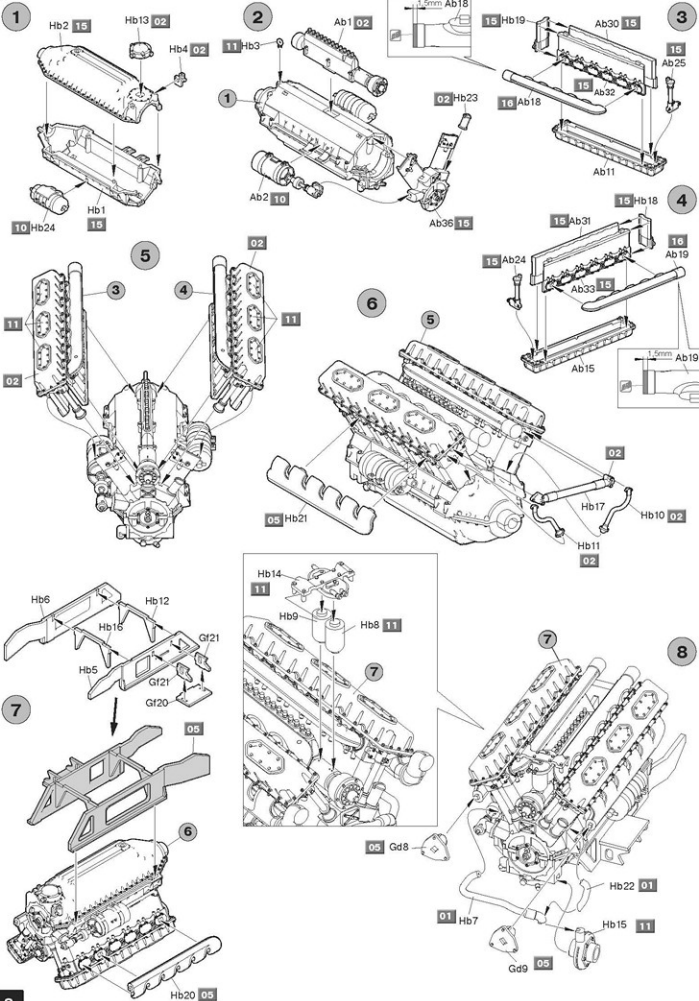

9

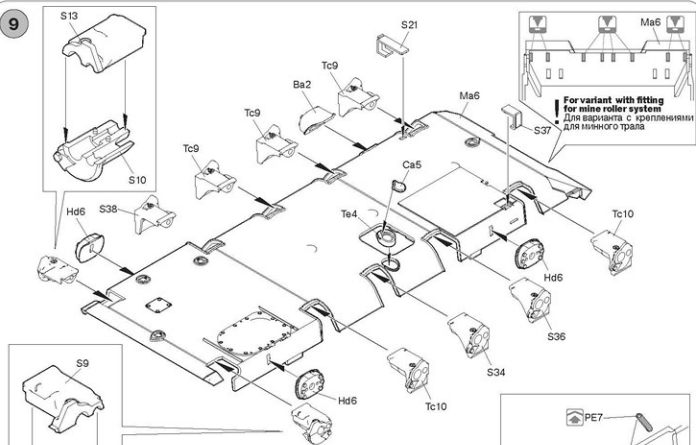

10

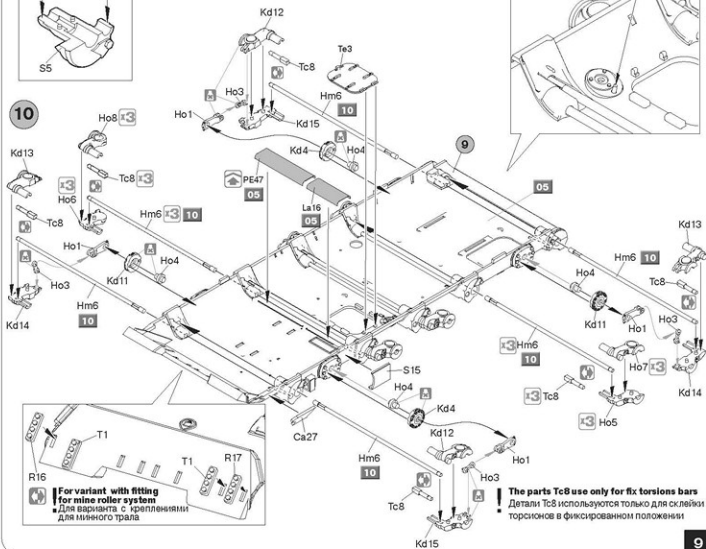

9

11

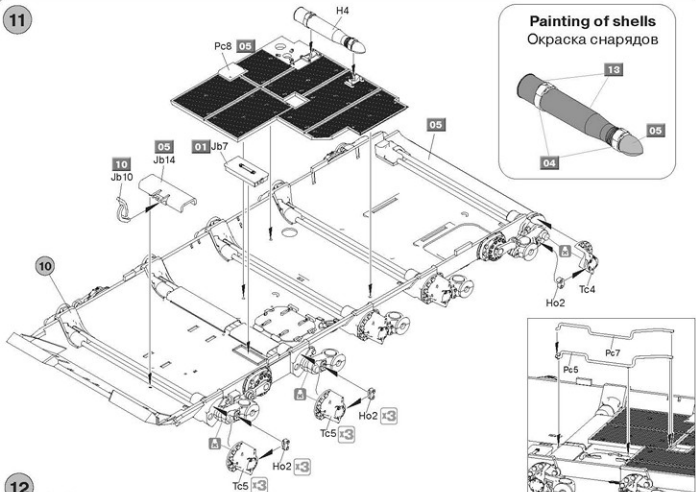

Painting of shells Окраска снарядов

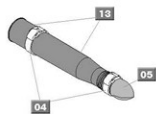

12

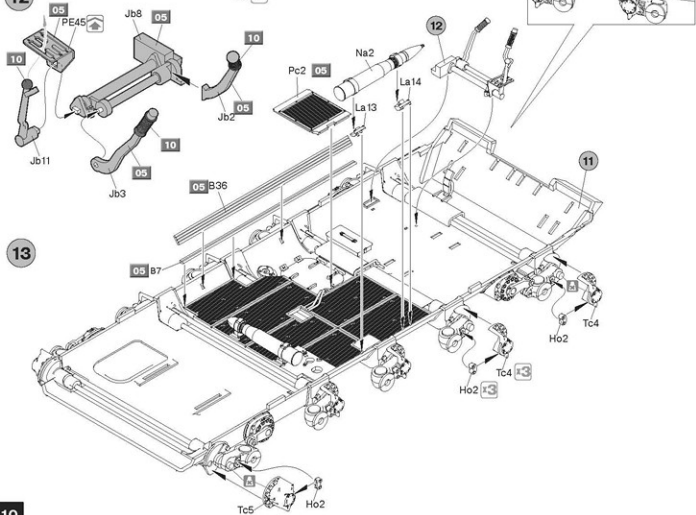

13

10

14

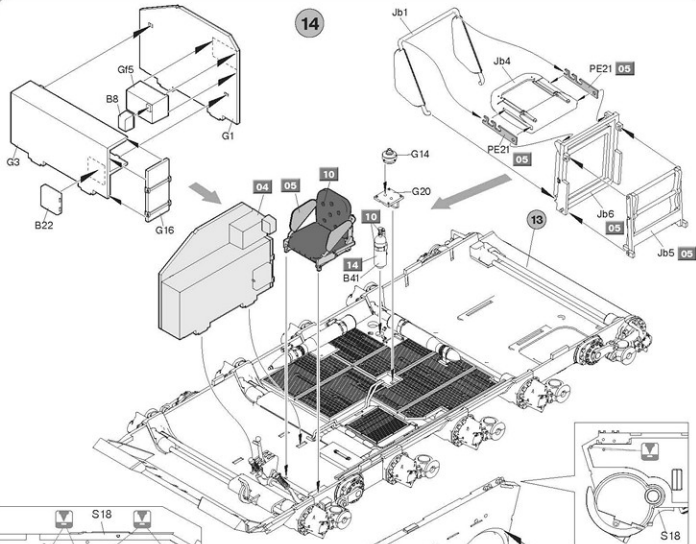

15

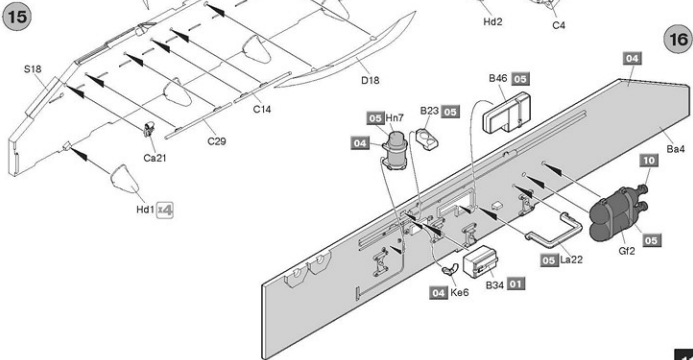

16

17

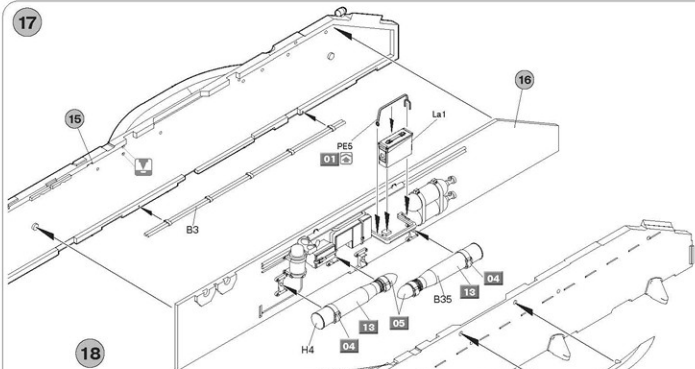

18

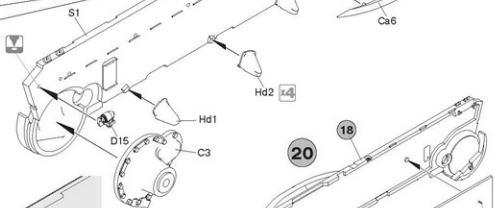
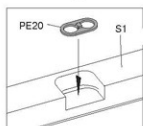

20

19

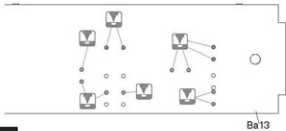
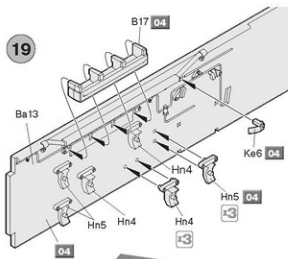

Ba13

21

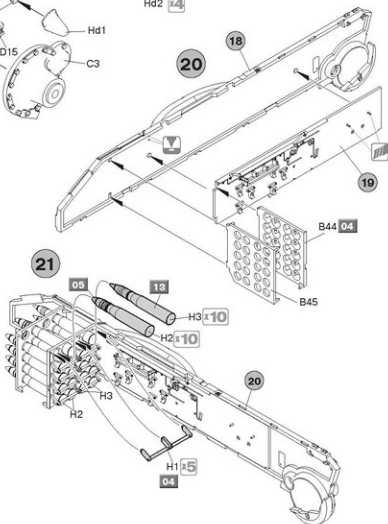

12

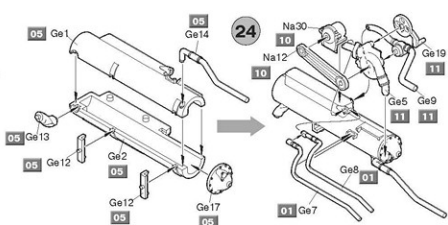
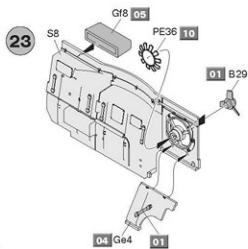
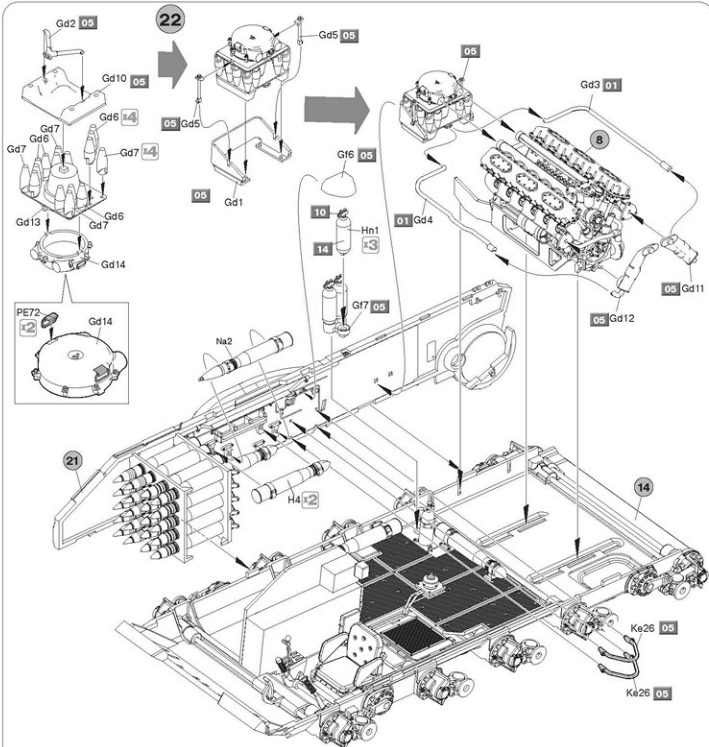

25

Pb2 3

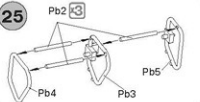

26 x10

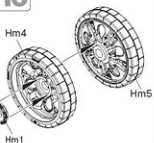

27

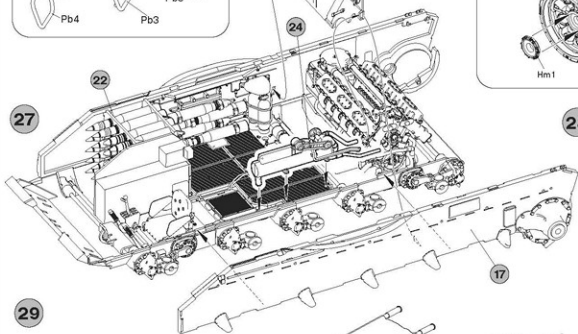

28

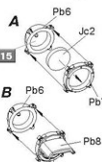

29

For variant with fitting
for mine roller system
Для варианта с креплением
для миныго траля

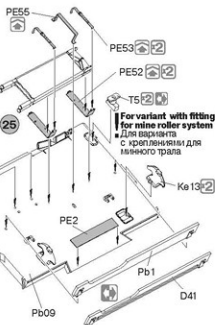
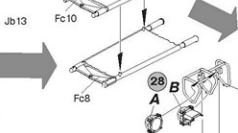

For variant with fitting
for mine roller system
Для варианта с креплением
для миныго траля

30

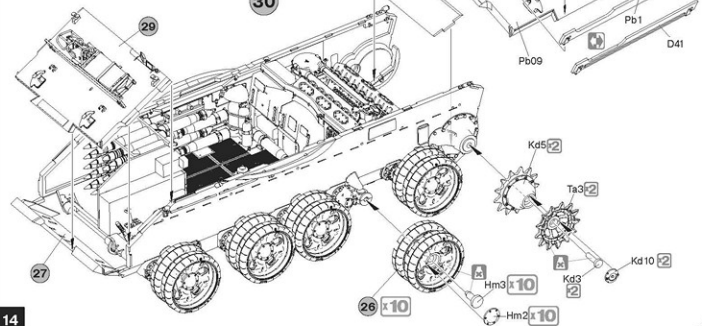

31

For variant with fitting
for mine roller system
Для борознота
с креплением для
миного трала

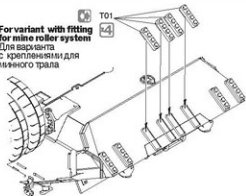

32

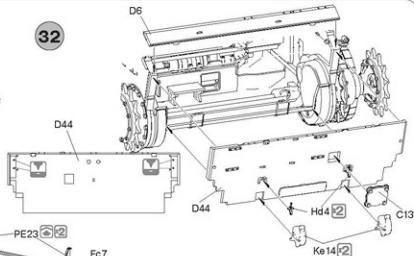

33

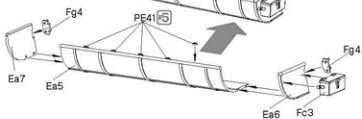
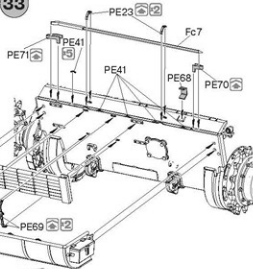
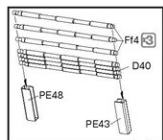

34

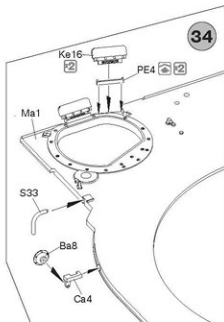

35

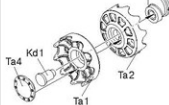
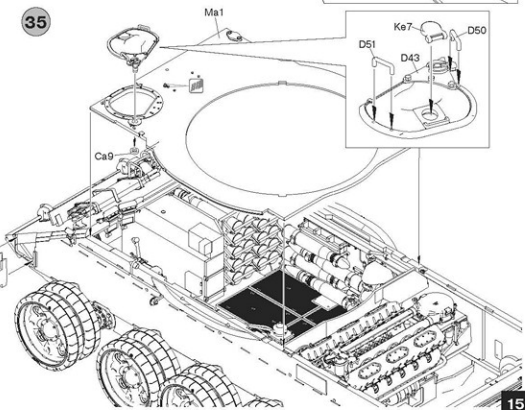
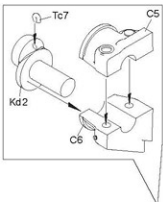

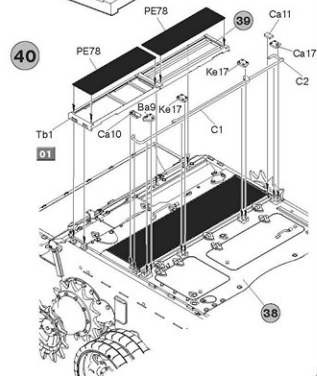
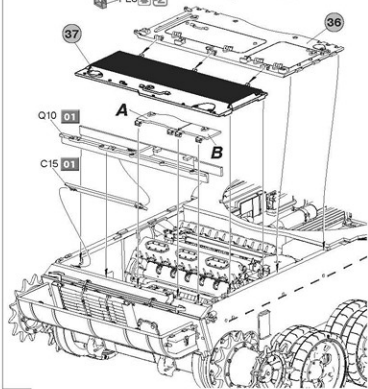
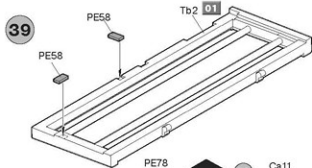
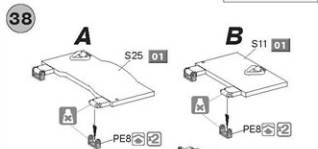
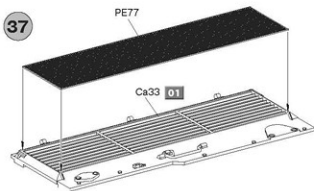
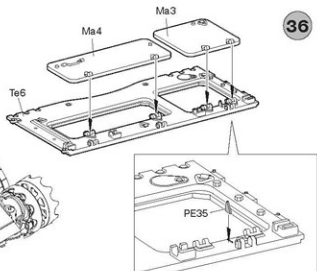
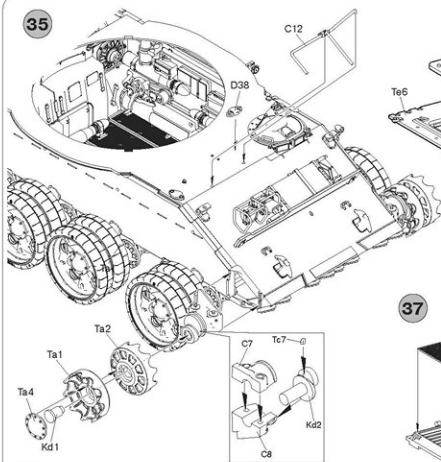

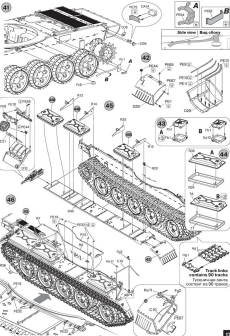

47

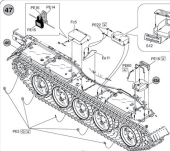

48

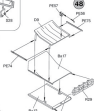

49

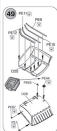

50



Track links
contains 50 tracks
Гусеница состоит
из 50 звеньев

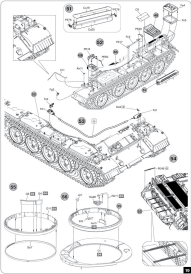

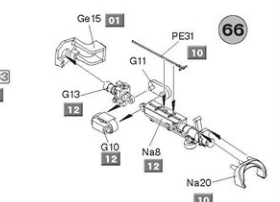
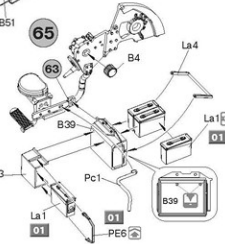
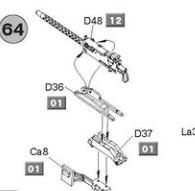
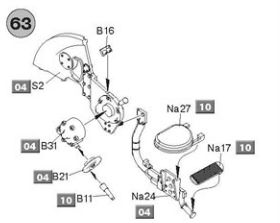
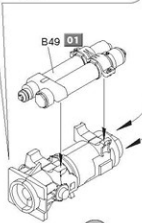
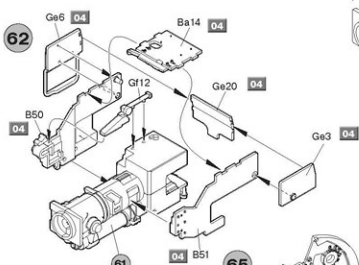
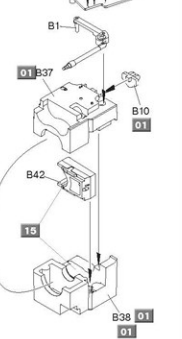
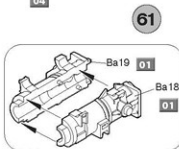
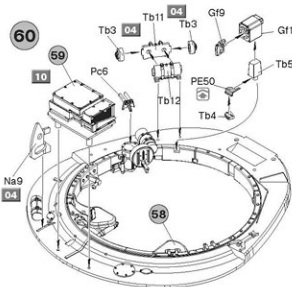
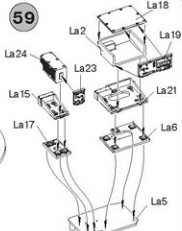
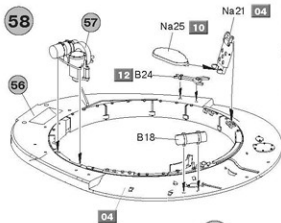
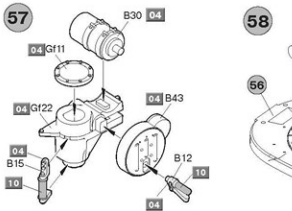

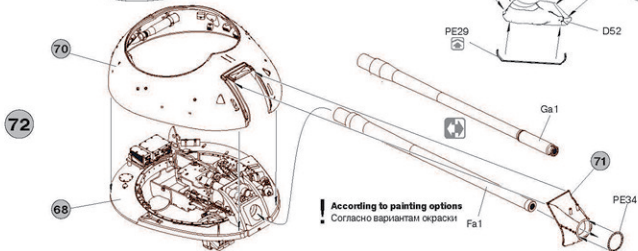
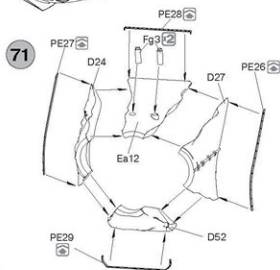
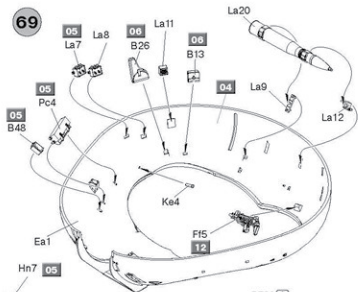
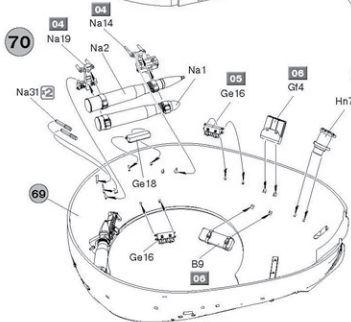
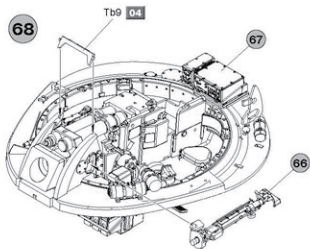
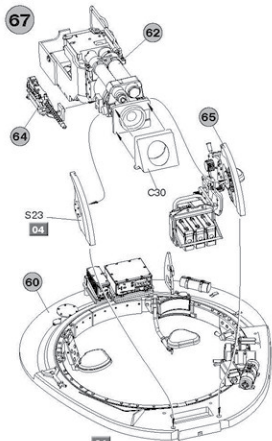

According to painting options

Согласно вариантам окраски

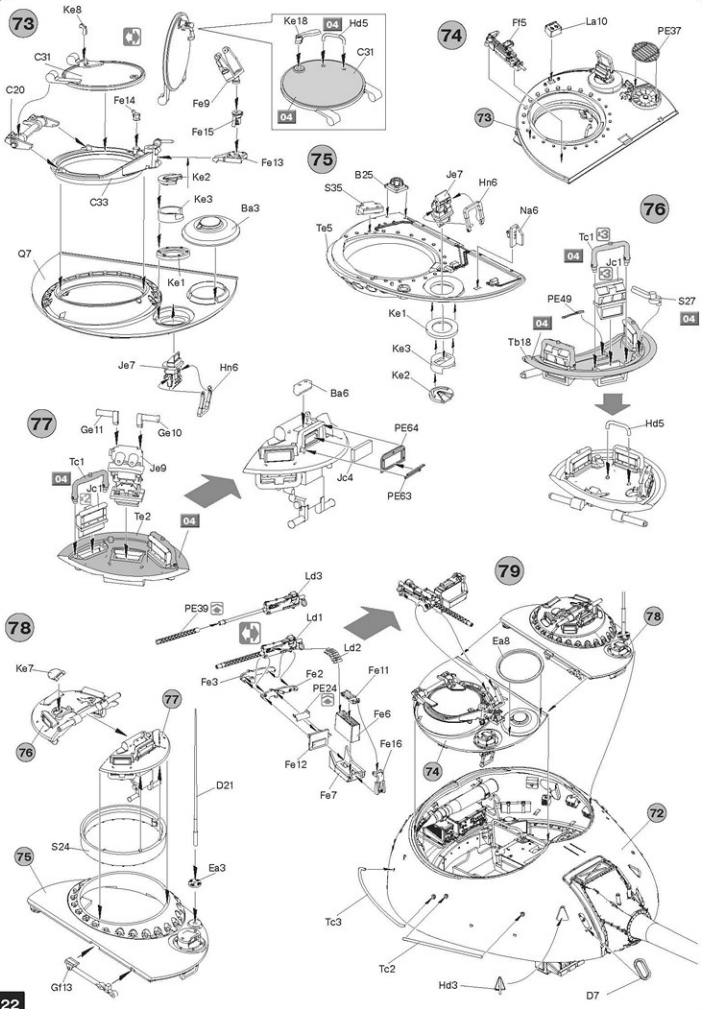

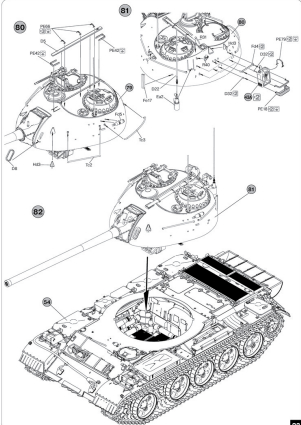

INTERIOR KIT
SYSTEMS OF INTERIORS RECONSTRUCTION

37010

**TIRAN 4
EARLY TYPE**

