

ATTENTION

- Read carefully and fully understand the instructions before starting.
- The kit suitable for adult and experienced modellers because of bonus materials such as resin parts & photo-etched details.
- Keep plastic bag away from small children! Suffocation hazard!
- The kit contains small parts, they can be dangerous if swallowed, keep away from reach of small children.
- When using cement, adhesives and paints, don't use these in closed room or near fire and use in well-ventilated room.
- Resin and photo-etched parts can be glued with cyanoacrylate.
- Avoid inhaling fumes because of irritate eyes, nose and throat or skin even.

KIT CONTENTS

Plastic parts

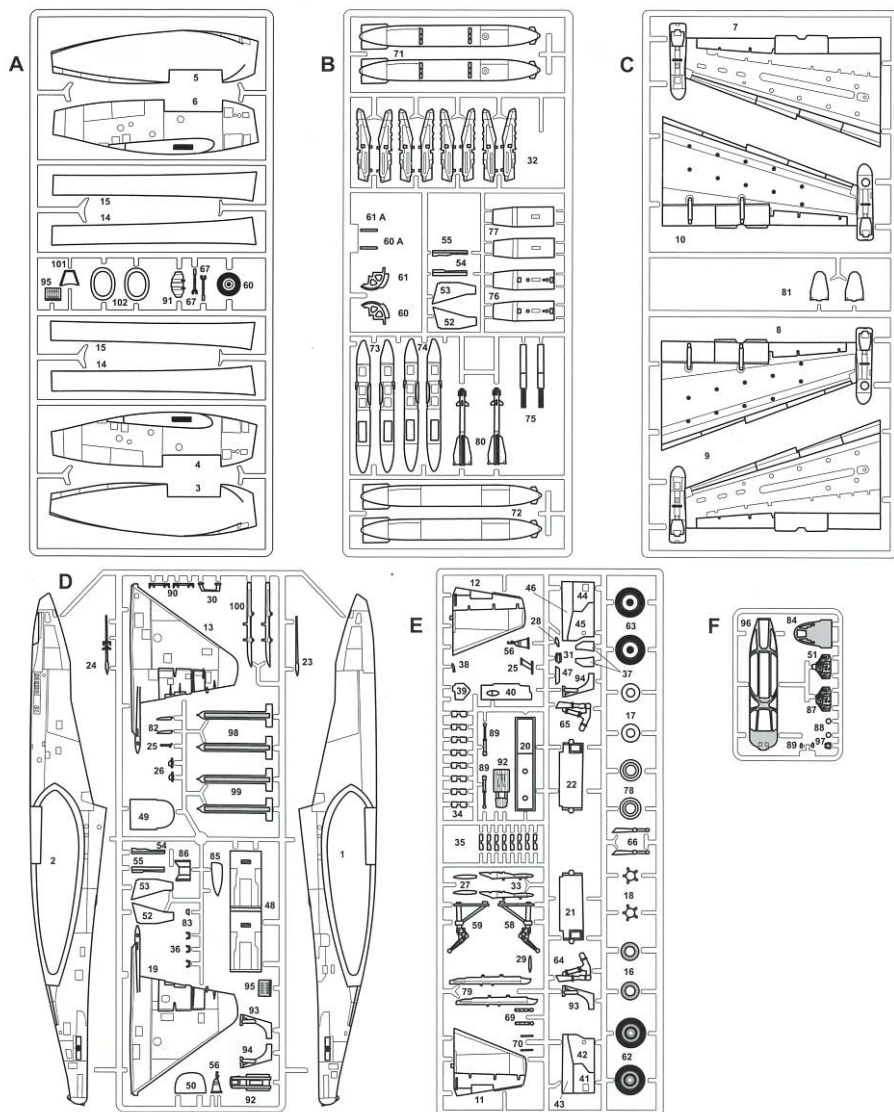

F-Film

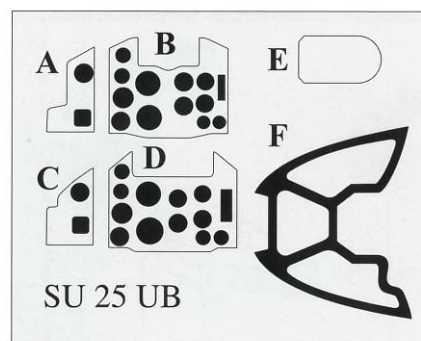

Quickmask

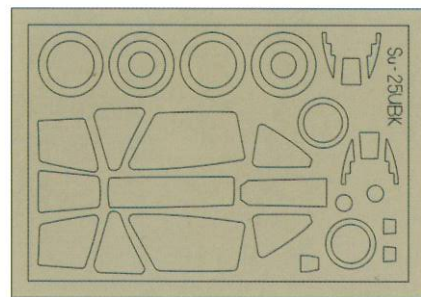

PE-Photo-etched parts

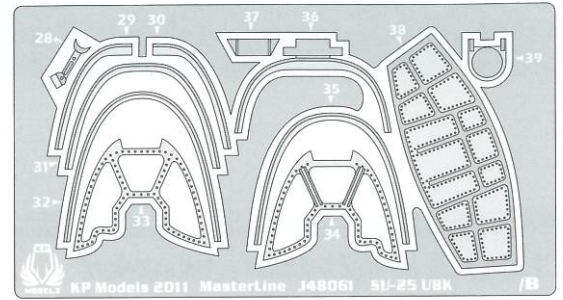
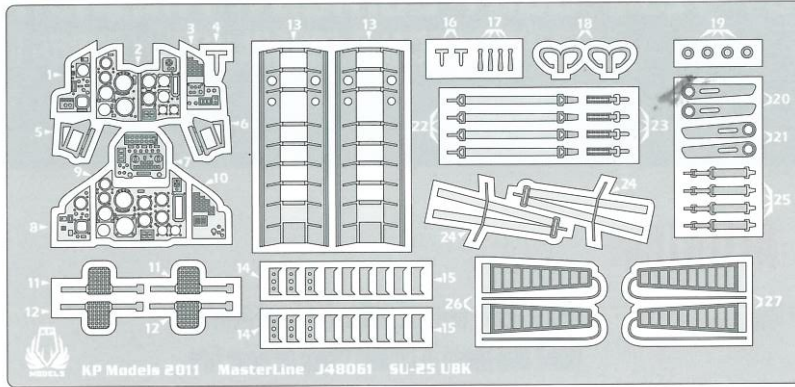

R-Resin parts

Cut and sand shaded casting sprues before using parts.

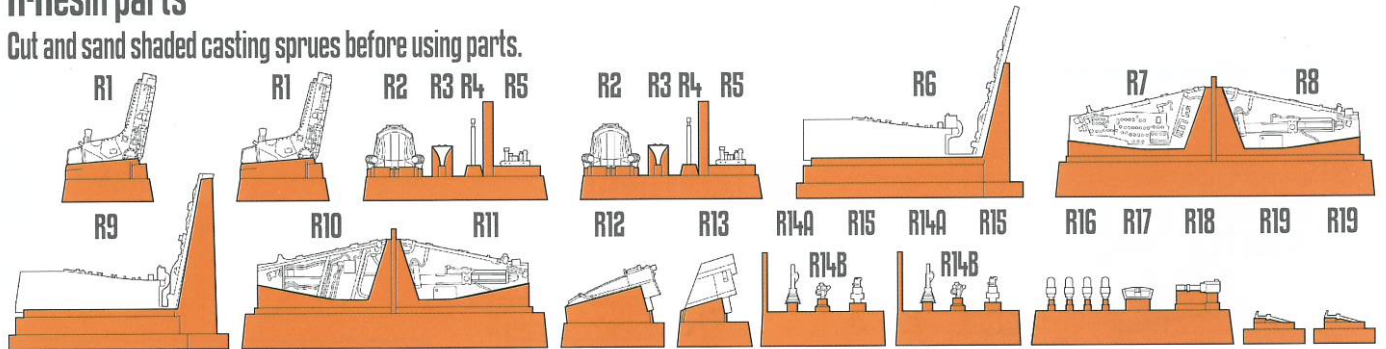

COLOURS

#	NAME	GUNZE HOBBY	GUNZE MR. COLOR
A	FLAT WHITE	H011	C61
B	FLAT BLACK	H012	C33
C	BRIGHT GREEN	H026	C66
D	WOOD BROWN	H037	C43
E	DEEP GREEN	H060	C16
F	SANDY BROWN	H066	C19
G	LIGHT BLUE	H067	C115
H	DARK EARTH	H072	C22
I	SANDY YELLOW	H079	C39
J	MAHOGANY	H084	C42
K	GREEN	H302	C302
L	MEDIUM GREEN	H303	C303
M	BROWN	H310	C310
N	PALE GREEN	H312	C312
O	LIGHT GREEN	H319	C319
P	DARK GREEN	H320	C320
Q	LIGHT GREY	H325	C325
R	GREYISH BLUE	H337	C337
S	FIELD GREEN	H340	C340
T	CHOCOLATE BROWN	H406	C406
U	LIGHT BLUE	H417	C417
METAL COLORS ALCLAD II			
V	ALUMINIUM		ALC-101
W	STEEL		ALC-112
X	JET EXHAUST		ALC-113
Y	STAINLESS STEEL		ALC-115
Z	GUN METAL		ALC-120

INSTRUCTION LEGEND



HIGHLY DETAILED COCKPIT

- ?** You have a choice to build the detailed cockpit from resin, photo-etched parts and film **OR** assemble the simplified cockpit using plastic parts.
- !** In case of you choose the high detailed cockpit please take care on proper assembly sequence.

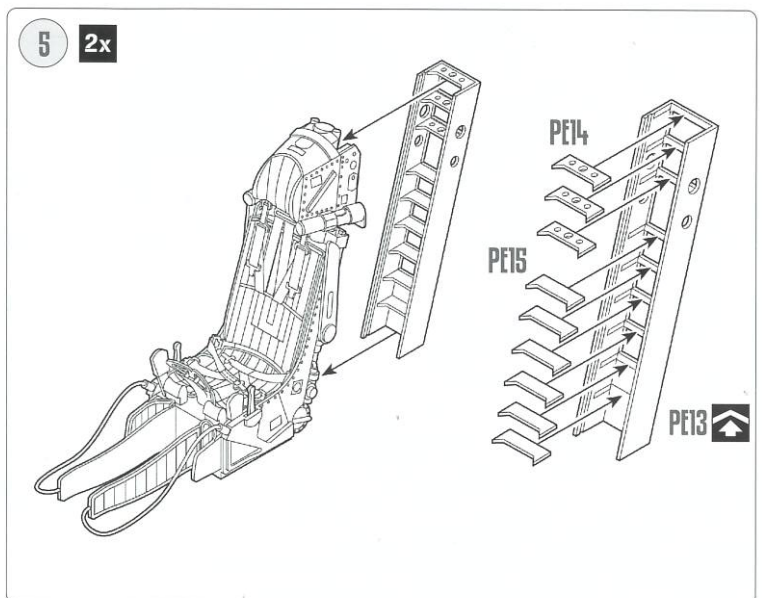
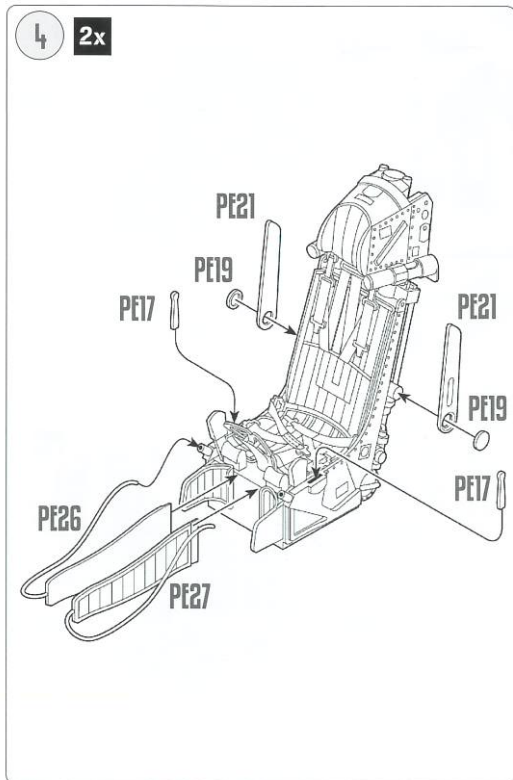
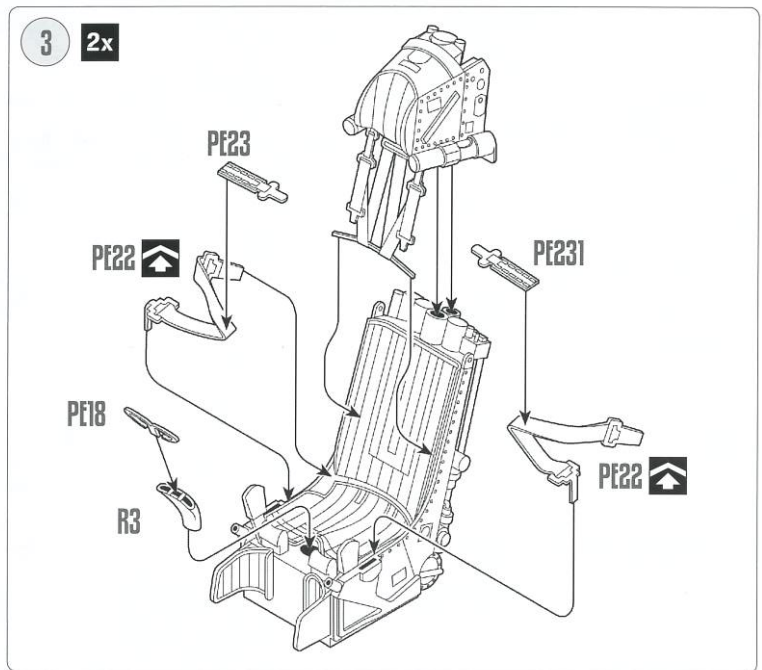
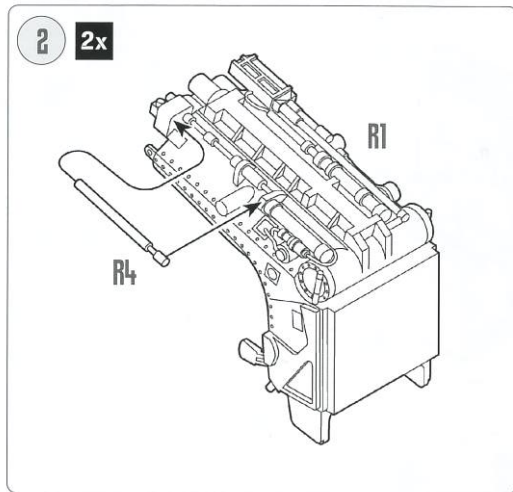
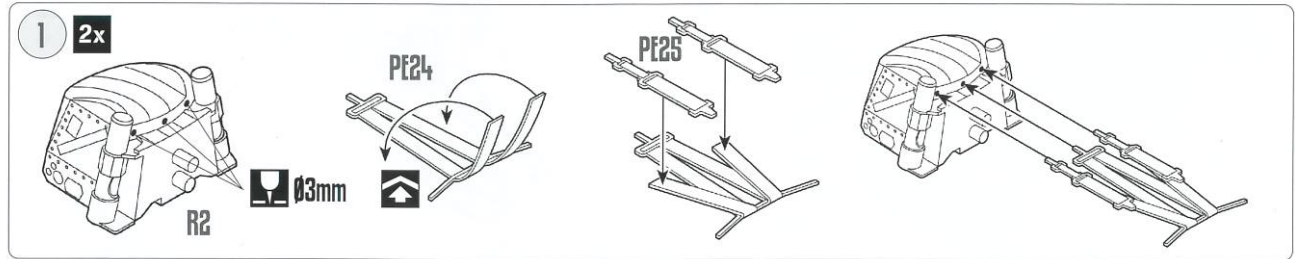

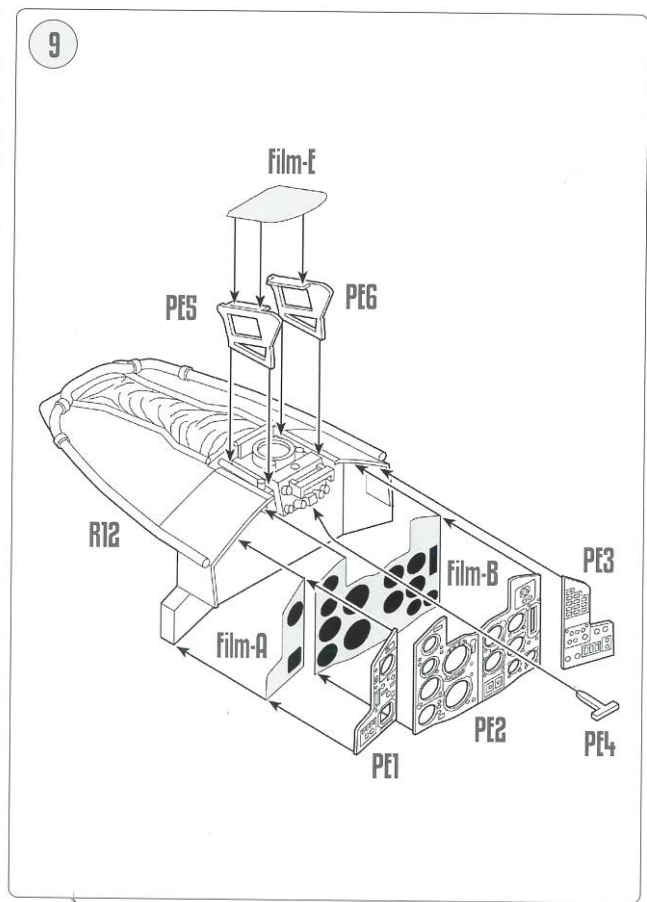
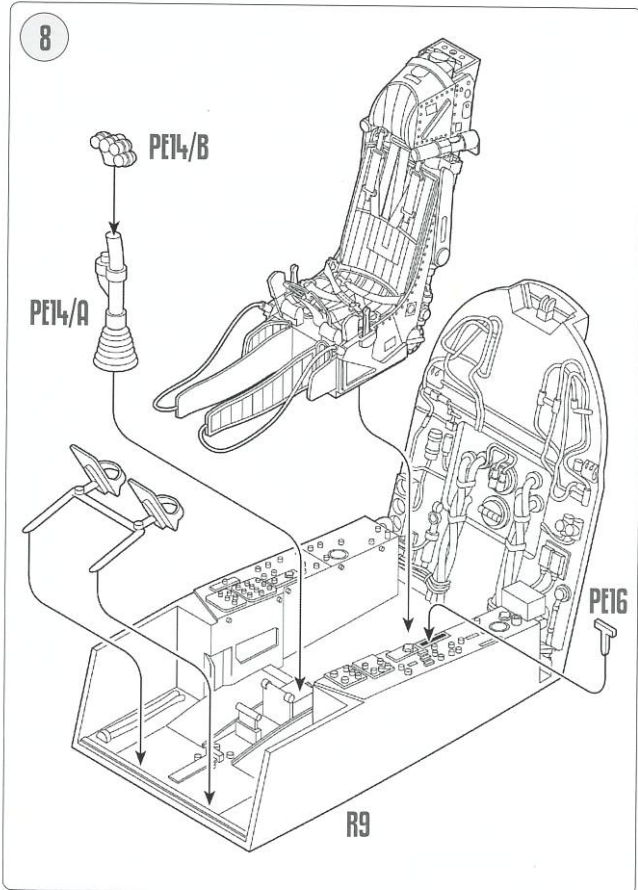
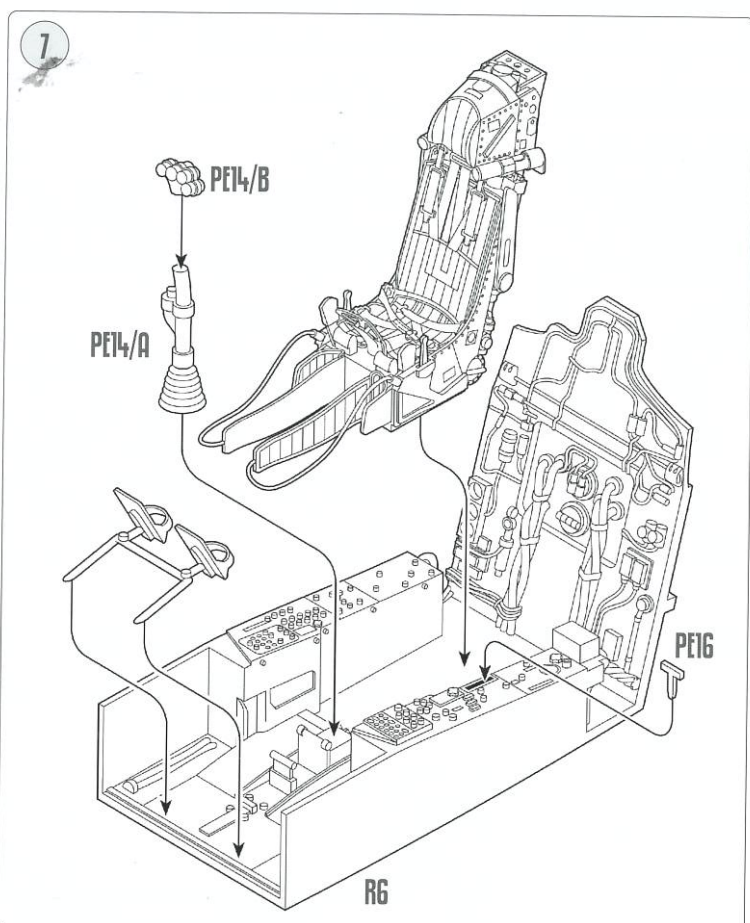
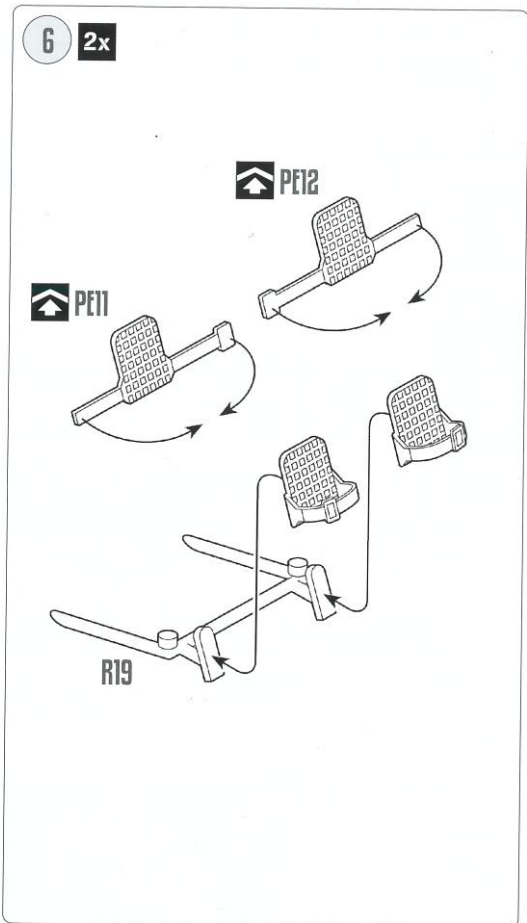

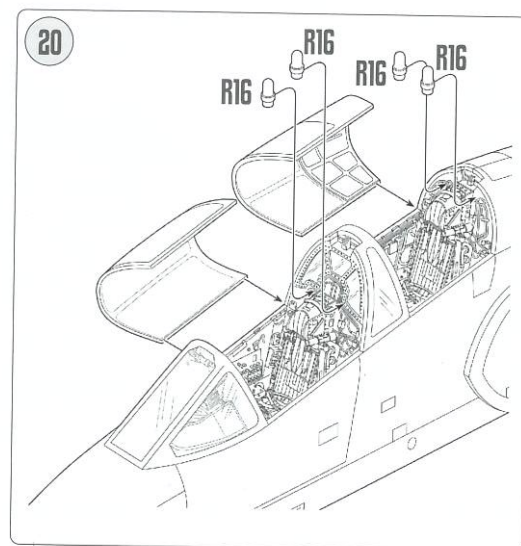
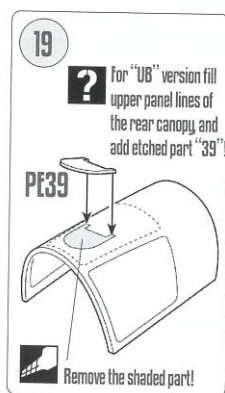
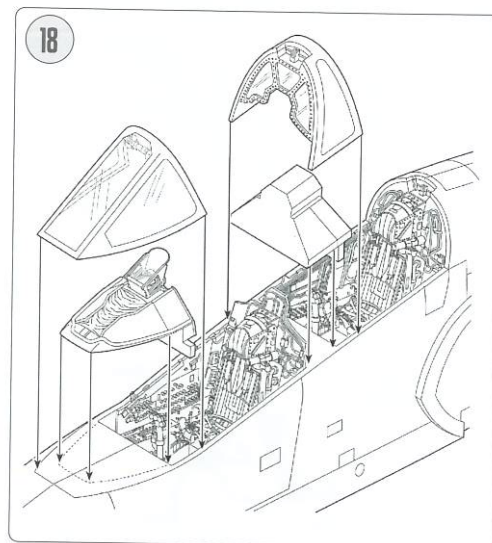
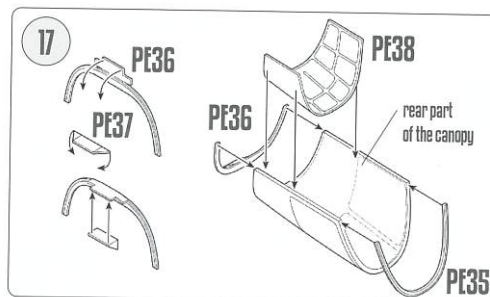
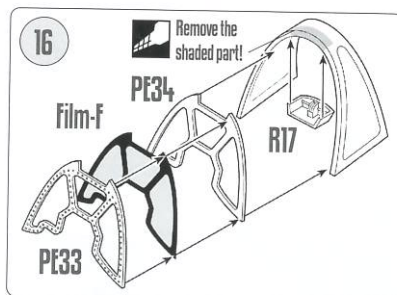
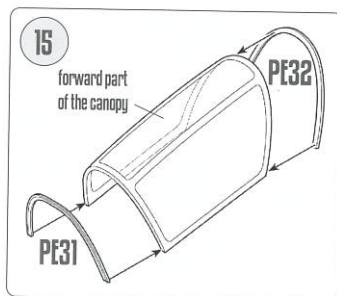
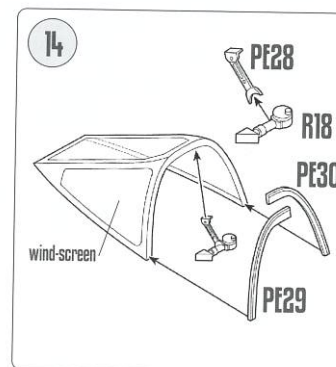
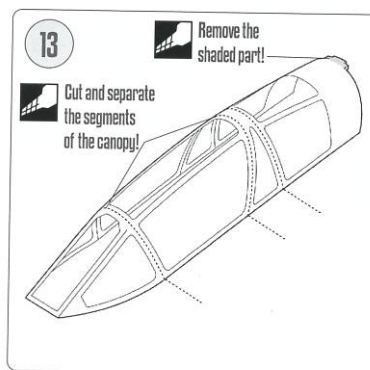
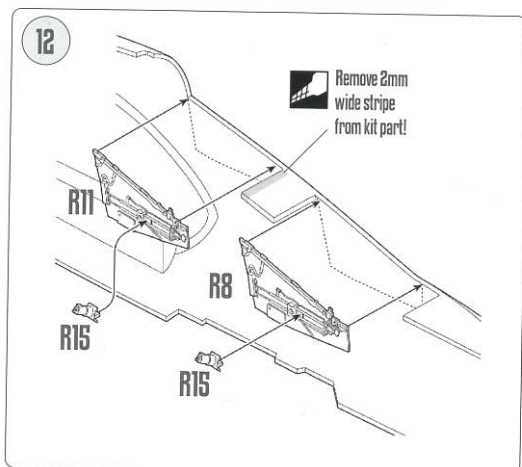
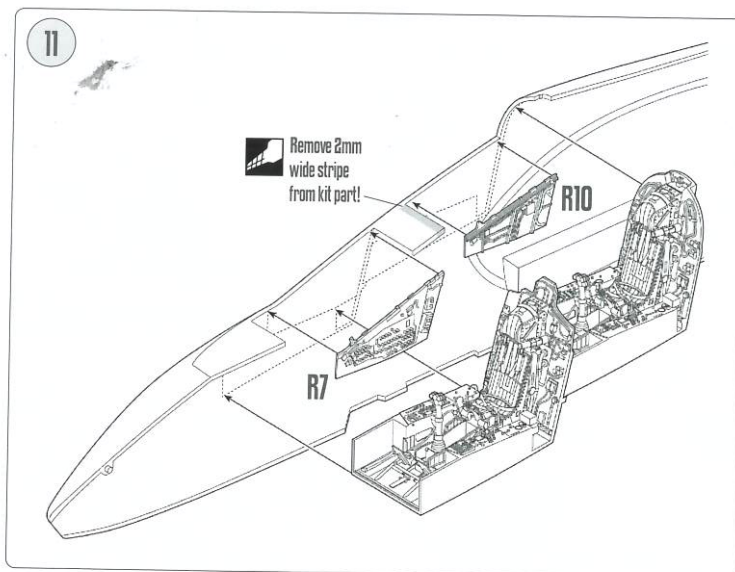
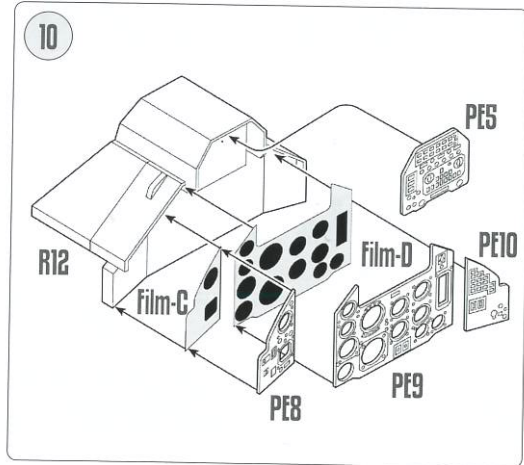

SIMPLIFIED COCKPIT

? You have a choice to build the detailed cockpit from resin, photo-etched parts and film **OR** assemble the simplified cockpit using plastic parts.

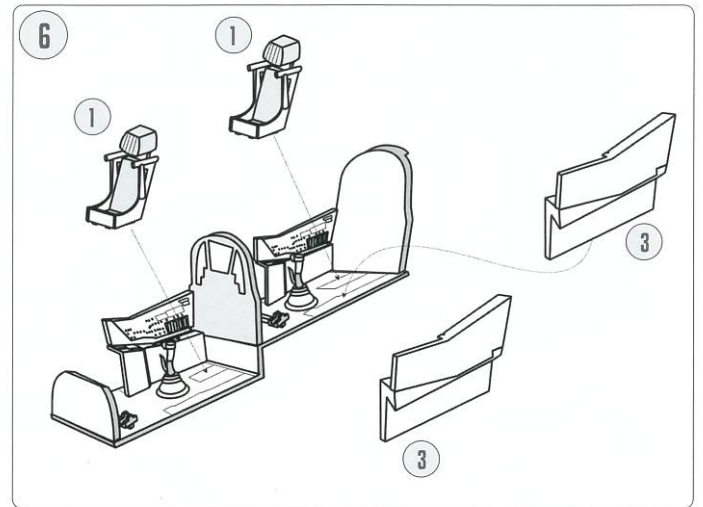
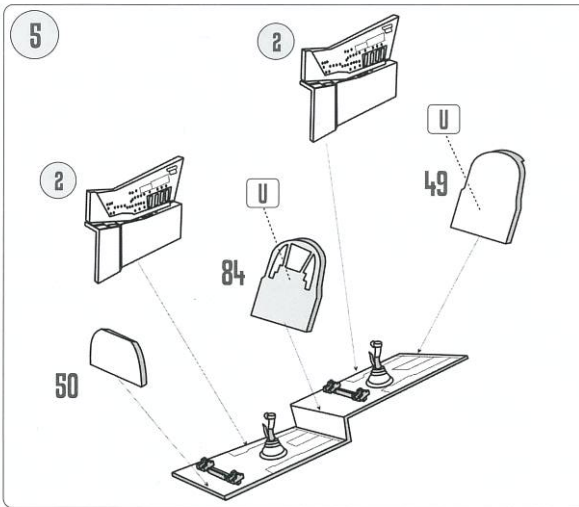
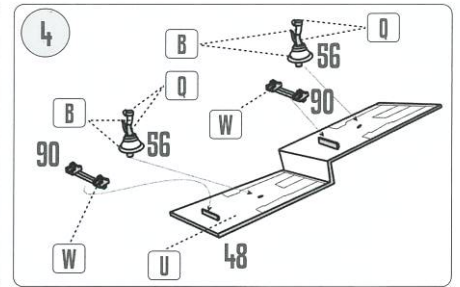
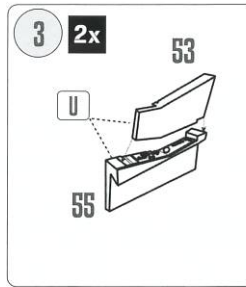
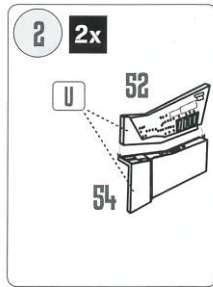
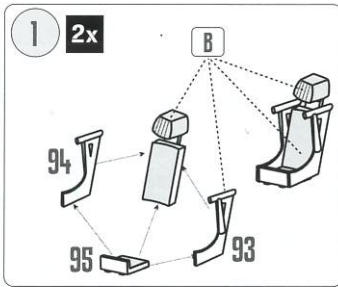

FUSELAGE

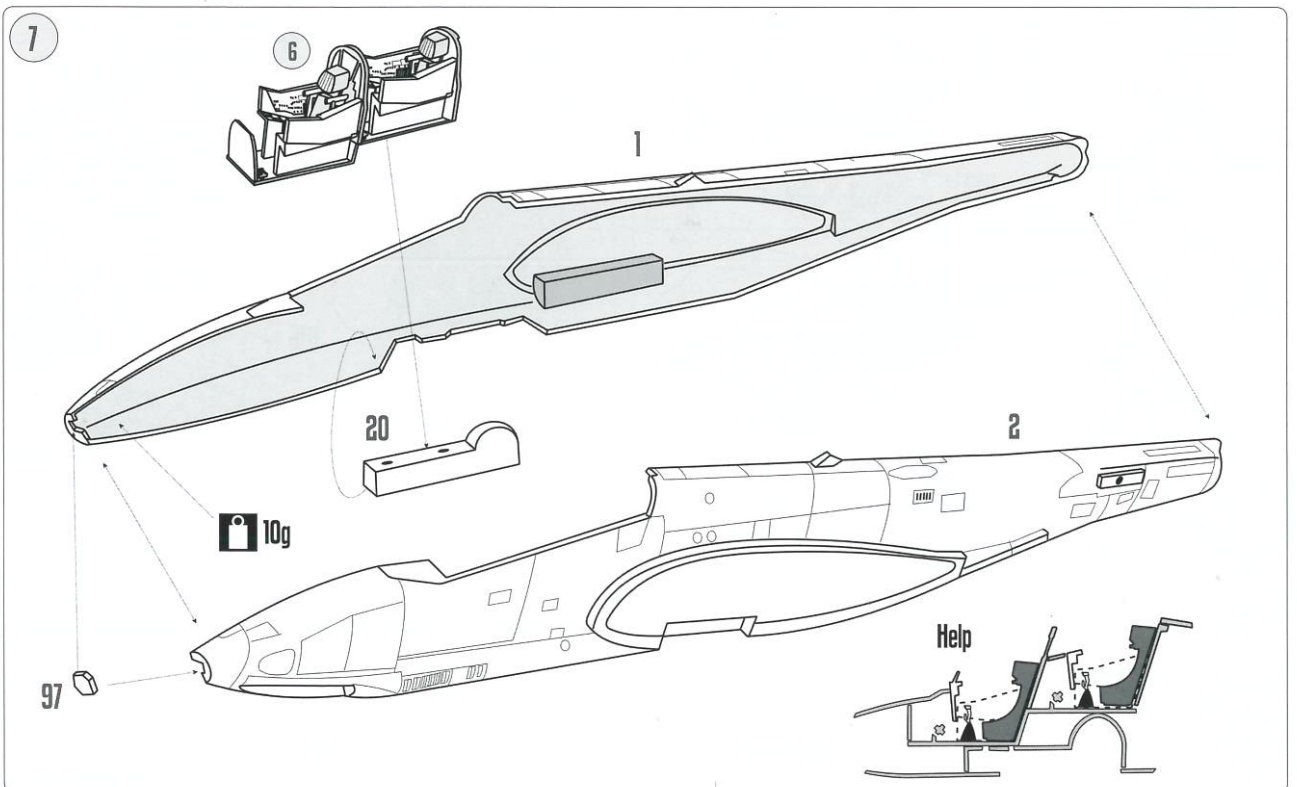

JET ENGINES

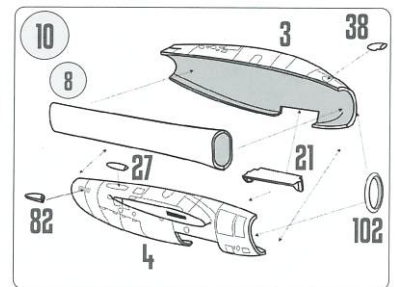
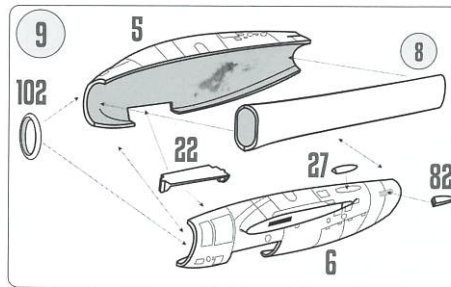
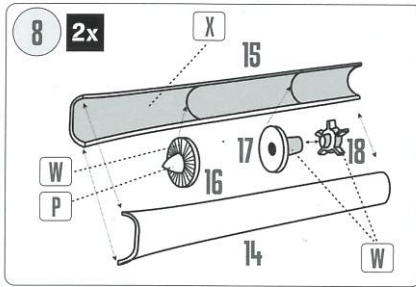

WINGS & STABILIZERS

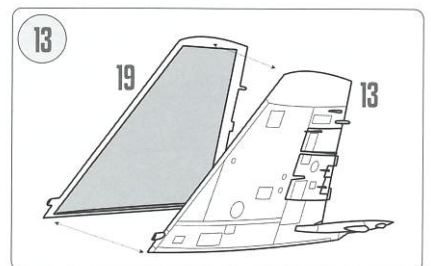
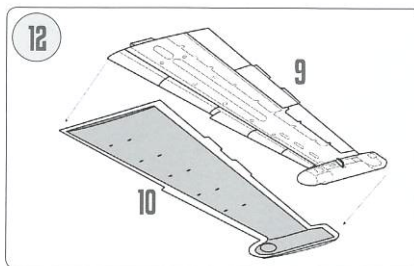
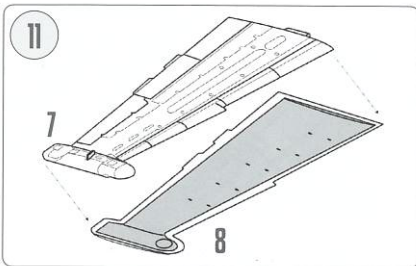

ATTACHING WINGS & ENGINES

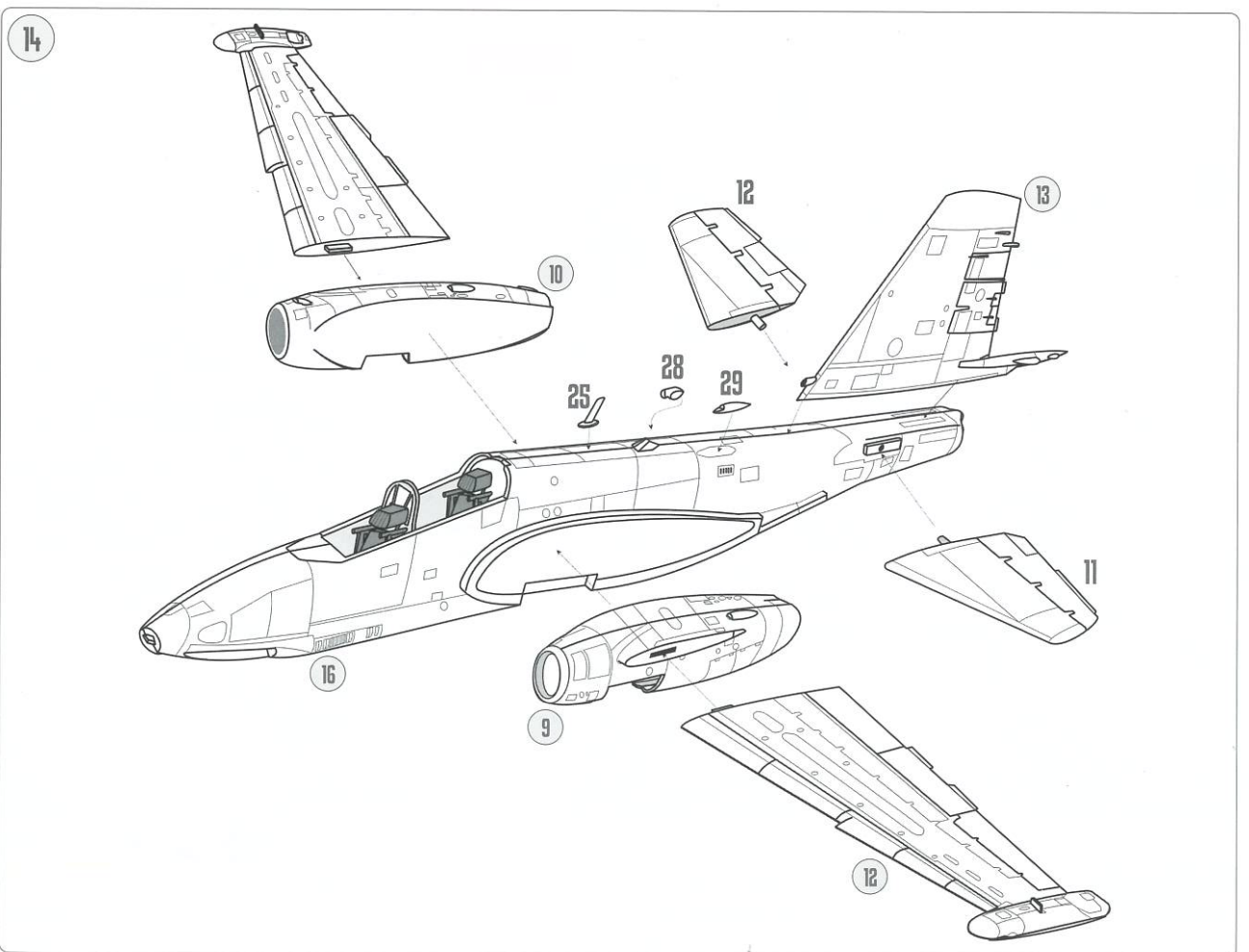

NOSE LANDING GEAR

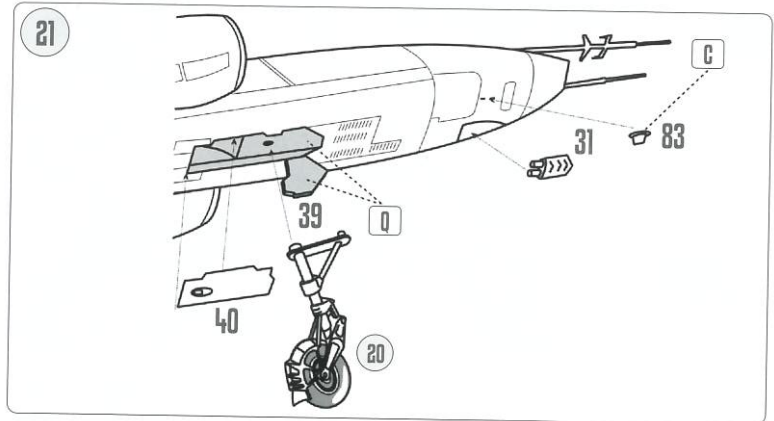
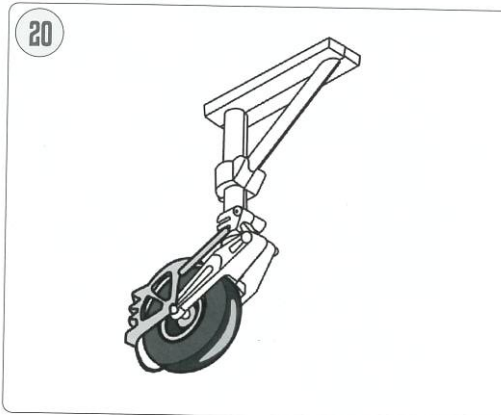
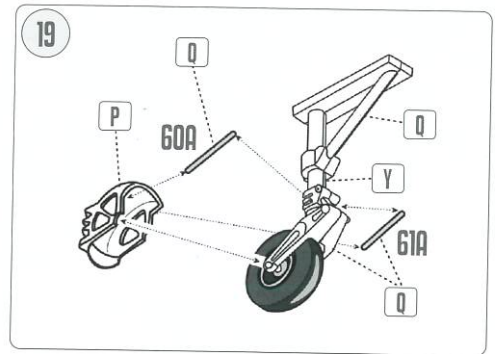
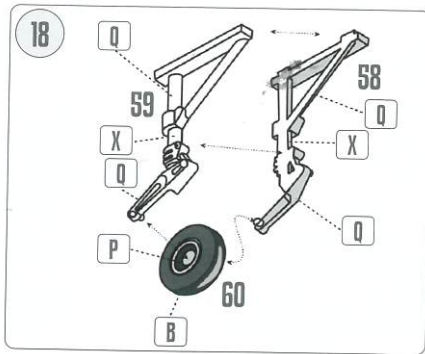
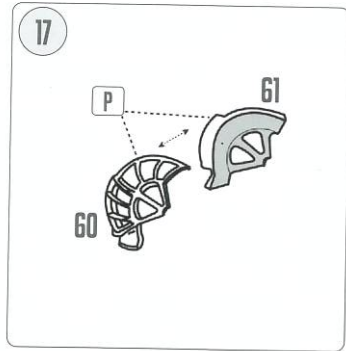

MAIN LANDING GEARS

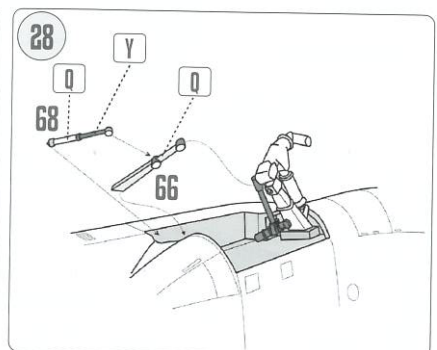
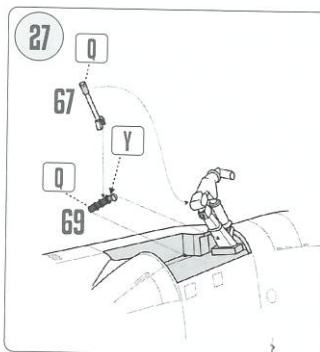
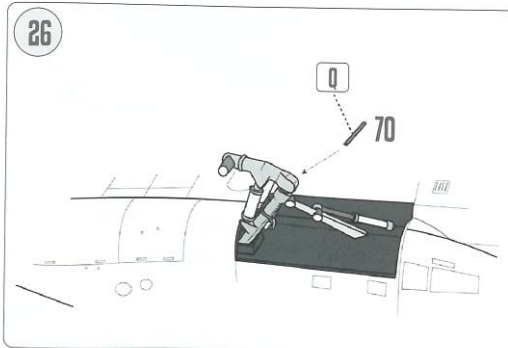
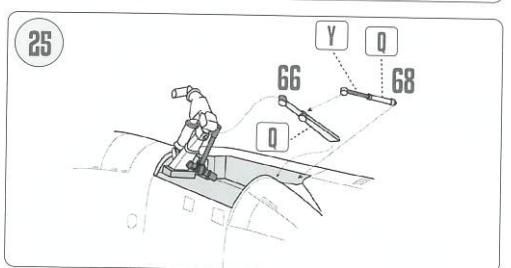
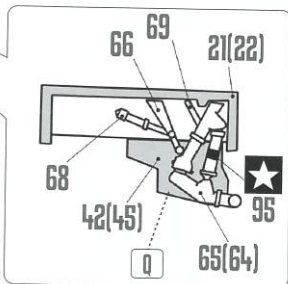
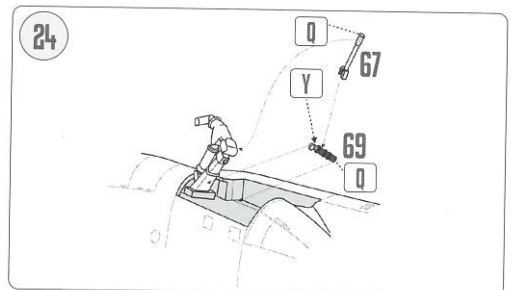
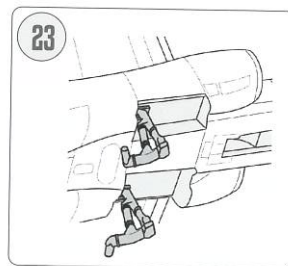
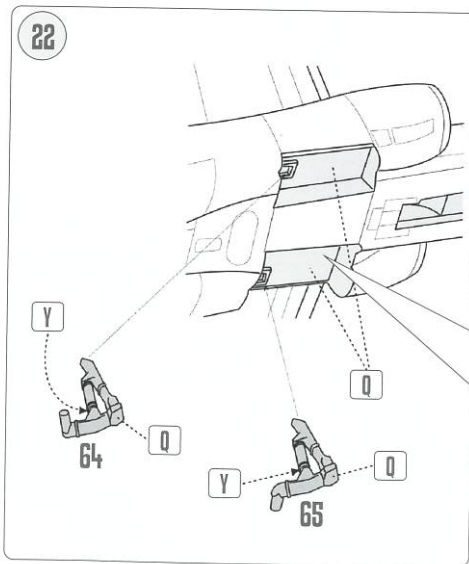

MAIN LANDING GEARS

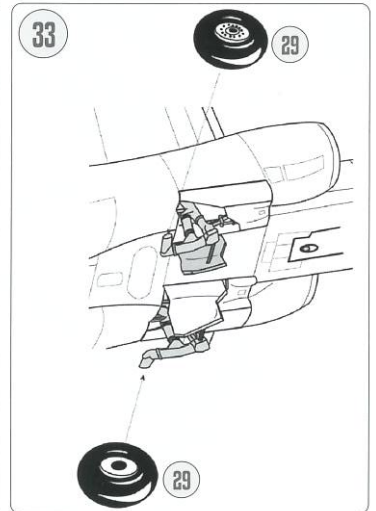
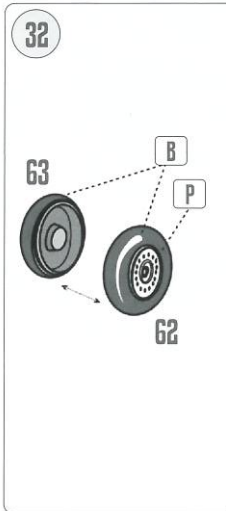
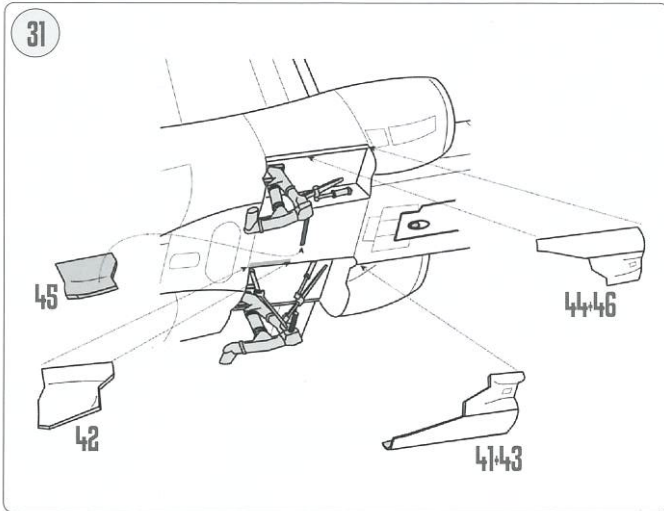
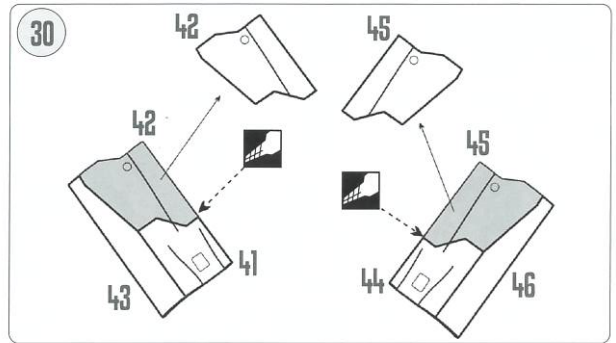
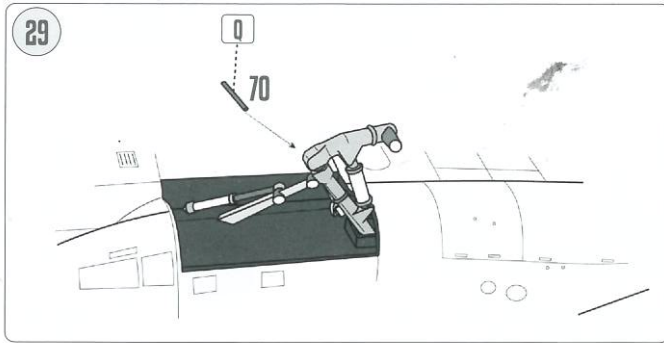

ARMAMENT ASSEMBLY

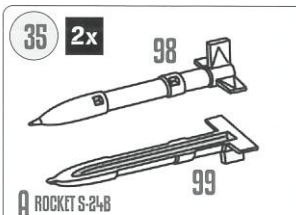
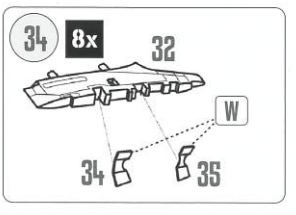

A ROCKET S-24B

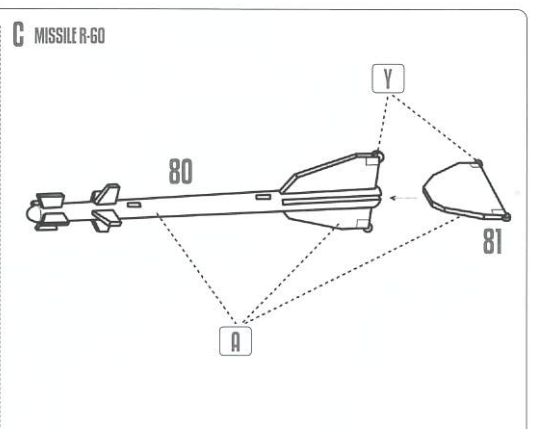
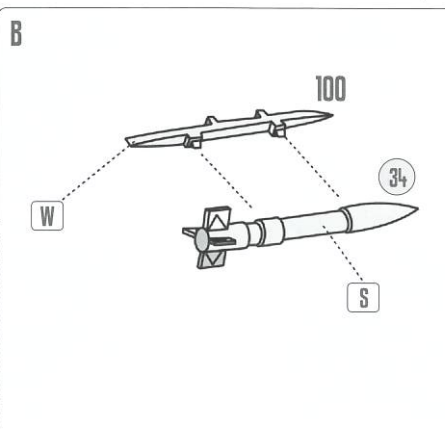

C MISSILE R-60

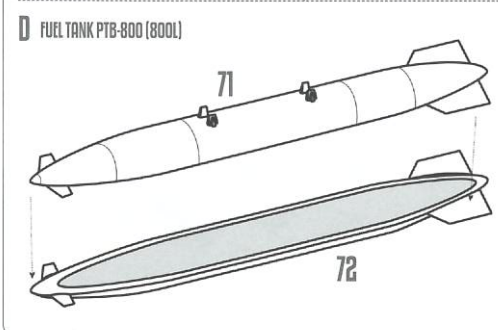

D FUEL TANK PTB-800 (800L)

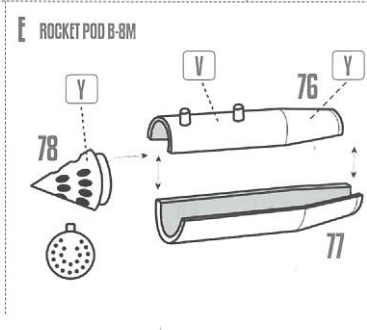

E ROCKET POD B-8M

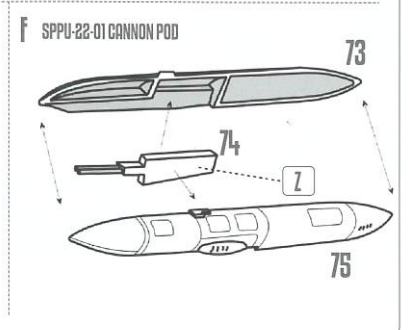

F SPPU-22-01 CANNON POD

ATTACHING PYLONS AND ACCESSORIES

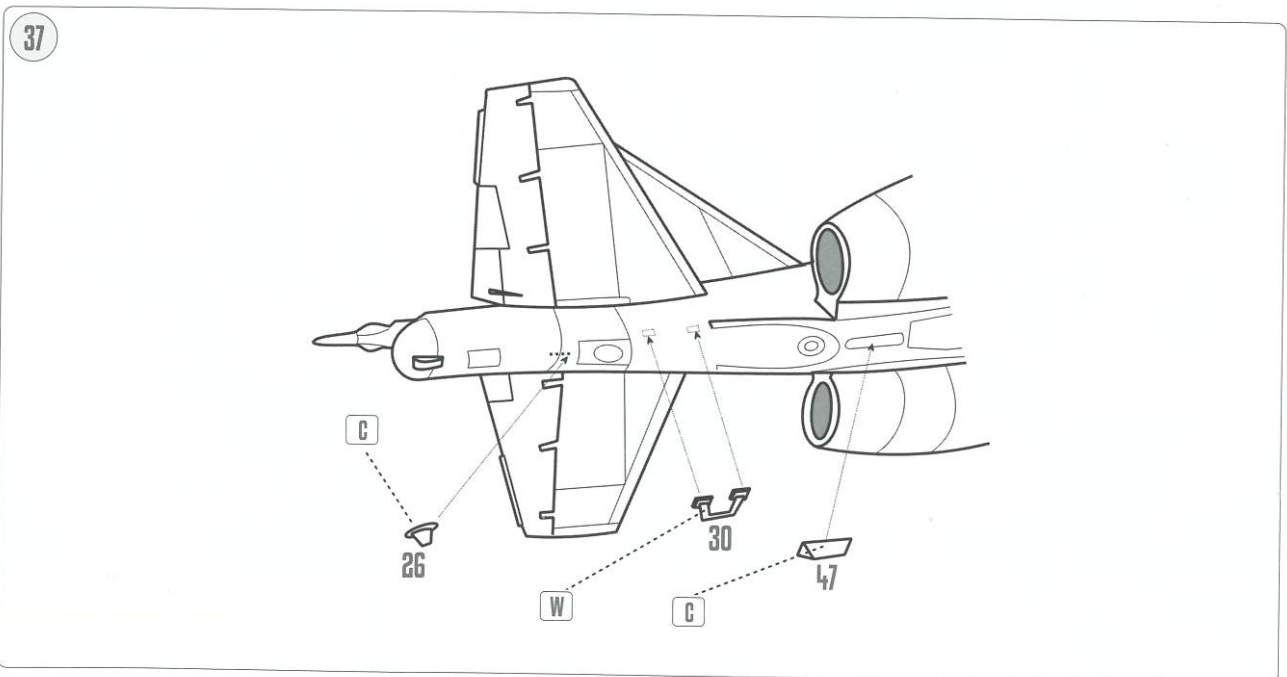
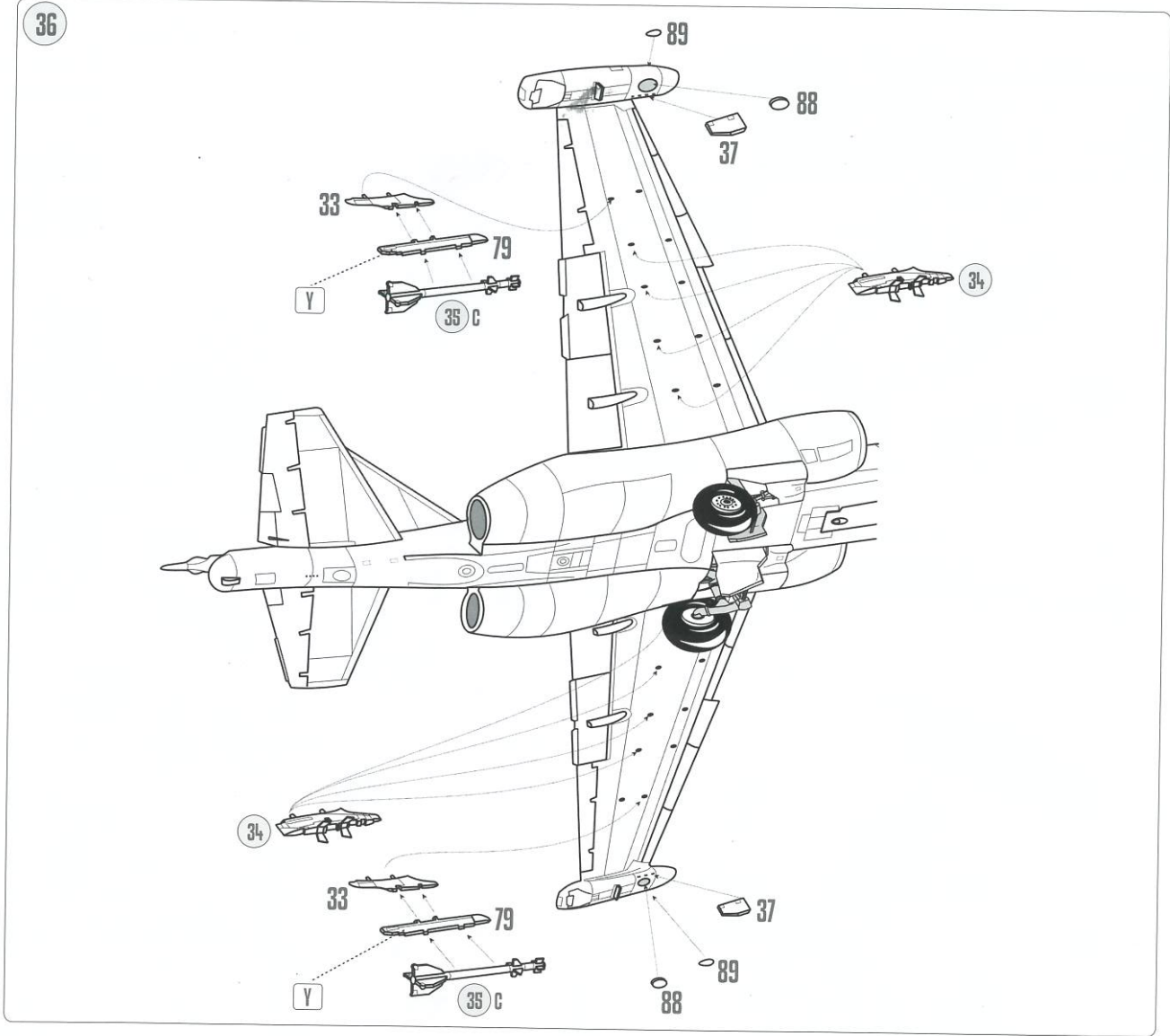

WEAPON LOAD CONFIGURATION

? To choose weapon and external fuel tank option please follow your reference!

38

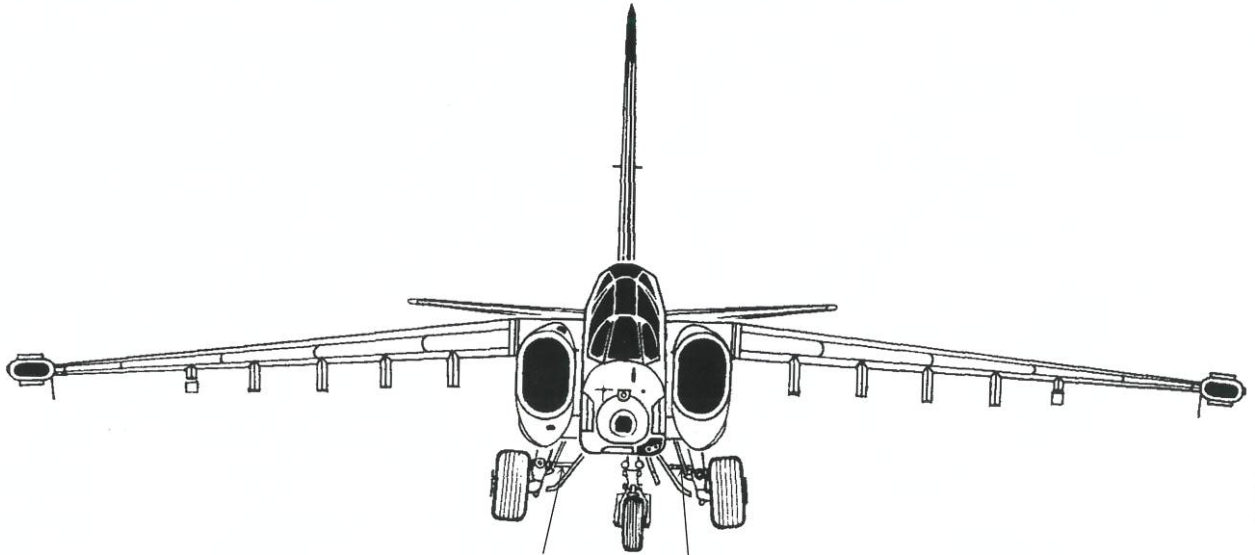

35 C



35 C



35 C



35 C



35 C



35 C



35 D



35 D



35 B



35 D



35 E



35 F



35 F



35 D



35 E



35 D



QUICKMASK APPLICATION

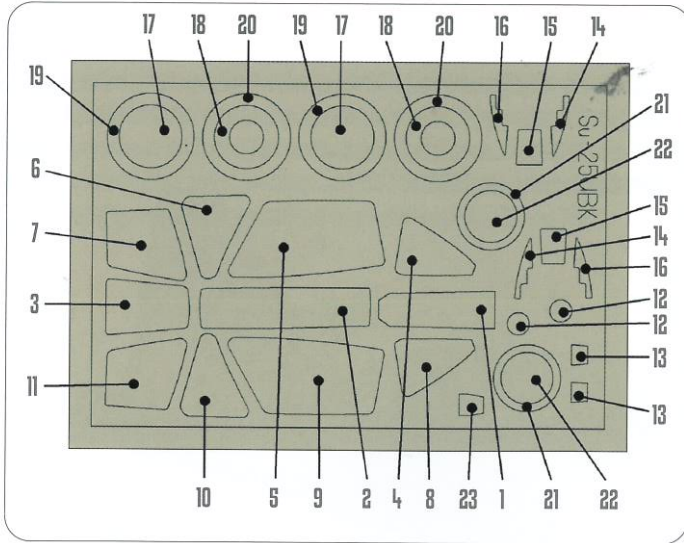

1 Kit Part No.
 Detail Mask
 Liquid paint mask

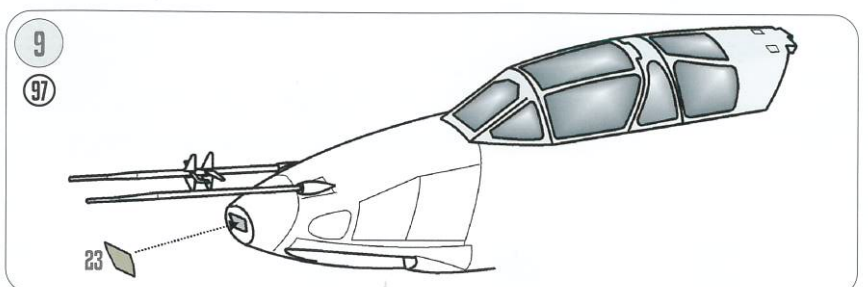
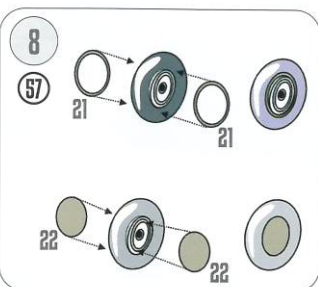
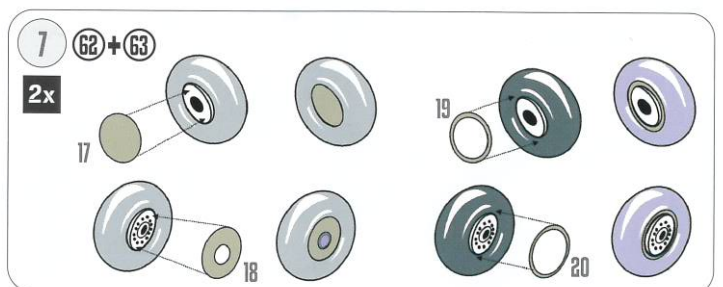
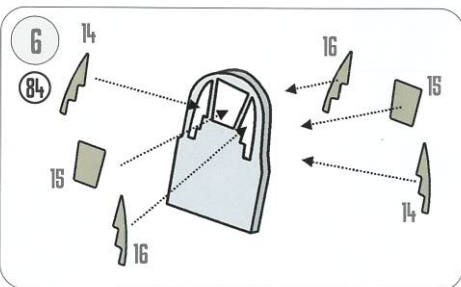
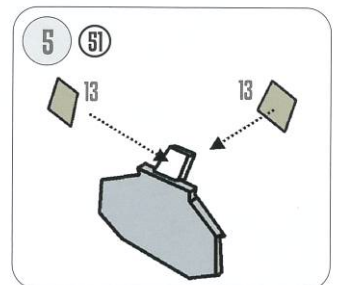
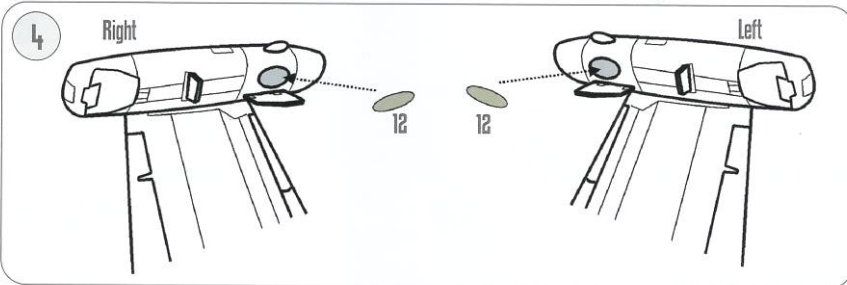
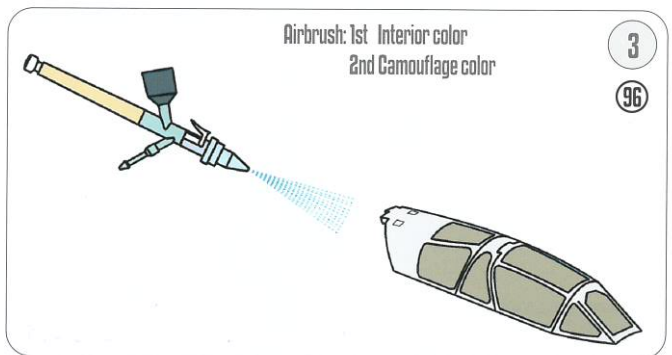
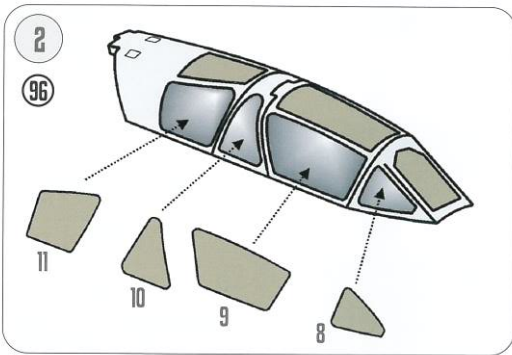
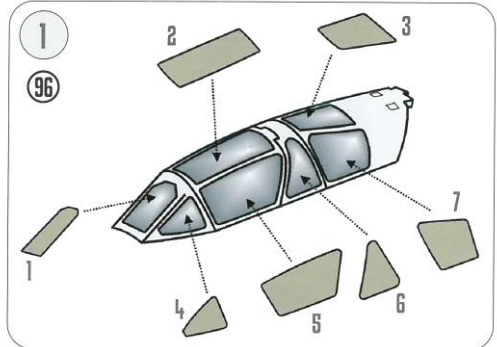

I. SU-25UBK Iran's Islamic Revolutionary Guards Corps Air Force Shiraz Shahid Dastghaib International airport - May 2009

Iran's Islamic Revolutionary Guards Corps Air Force - as known as Pasdaran - is a recent Su-25 operator. In 1991, seven Iraqi Su-25s were flown to Iran in an effort to find a temporary safe haven from Operation Desert Storm attacks on major Iraqi airfields and seized by the Iranian military. However, as a result of lack of spare parts, documentation, and pilot training, these aircraft never flown by the Iranian Air force. Pasdaran has added at least six new Su-25 aircraft to its inventory and has since likely restored ex-Iraqi Su-25s to flight status as well. This two-seat training-combat capable version of the Su-25 photographed on Shiraz Shahid Dastghaib International airport in May 2009.

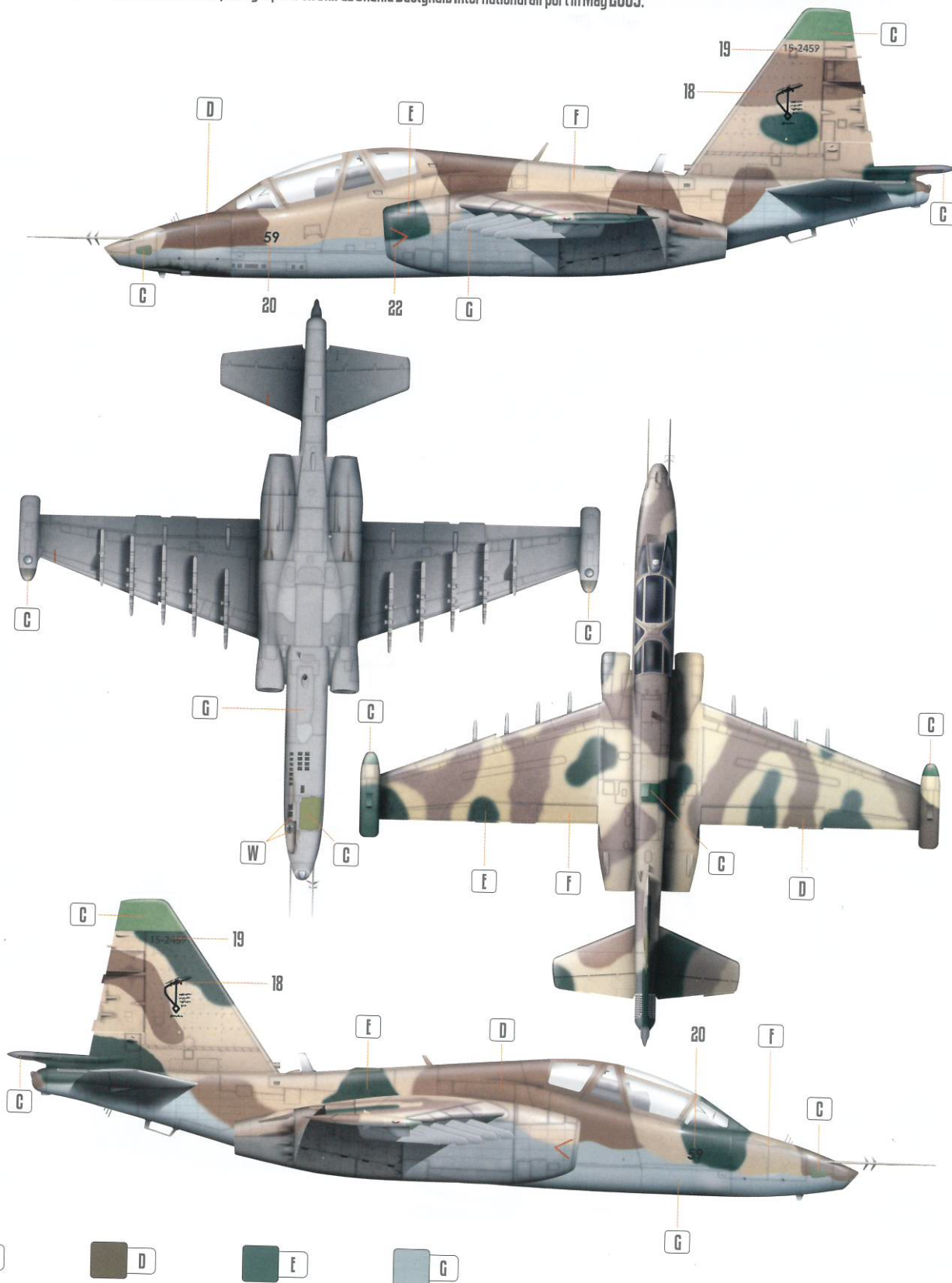

II. Su-25UB Peruvian Air Force

Grupo Aereo 11, Escuadron Aereo 112 - El Pato AB (aka Los Tigres), 2005

The Peruvian Air force (Fuerza Aérea del Perú, abbreviated FAP) having learned hard lesson after Cenepa conflict against Ecuador, FAP decided to reinforce itself in CAS capabilities to protect troops on the ground. Eight Su-25UBs (plus ten single-seater) delivered to La Joya airbase along with Mig-29s during 1997-1998 after a deal with Belarus. Their existence was a secret until 1999 when it was officially revealed by local authorities. In recent times their home is El Pato AB (aka The Tigers' House) at the north of the country. All Peruvian Frogfoots wore the two-green camouflage until 2007, then half of the fleet were switched to new blue-grey camouflage. Only three Su-25UBs were painted with impressive tiger head on the nose (080, 082 and 085).

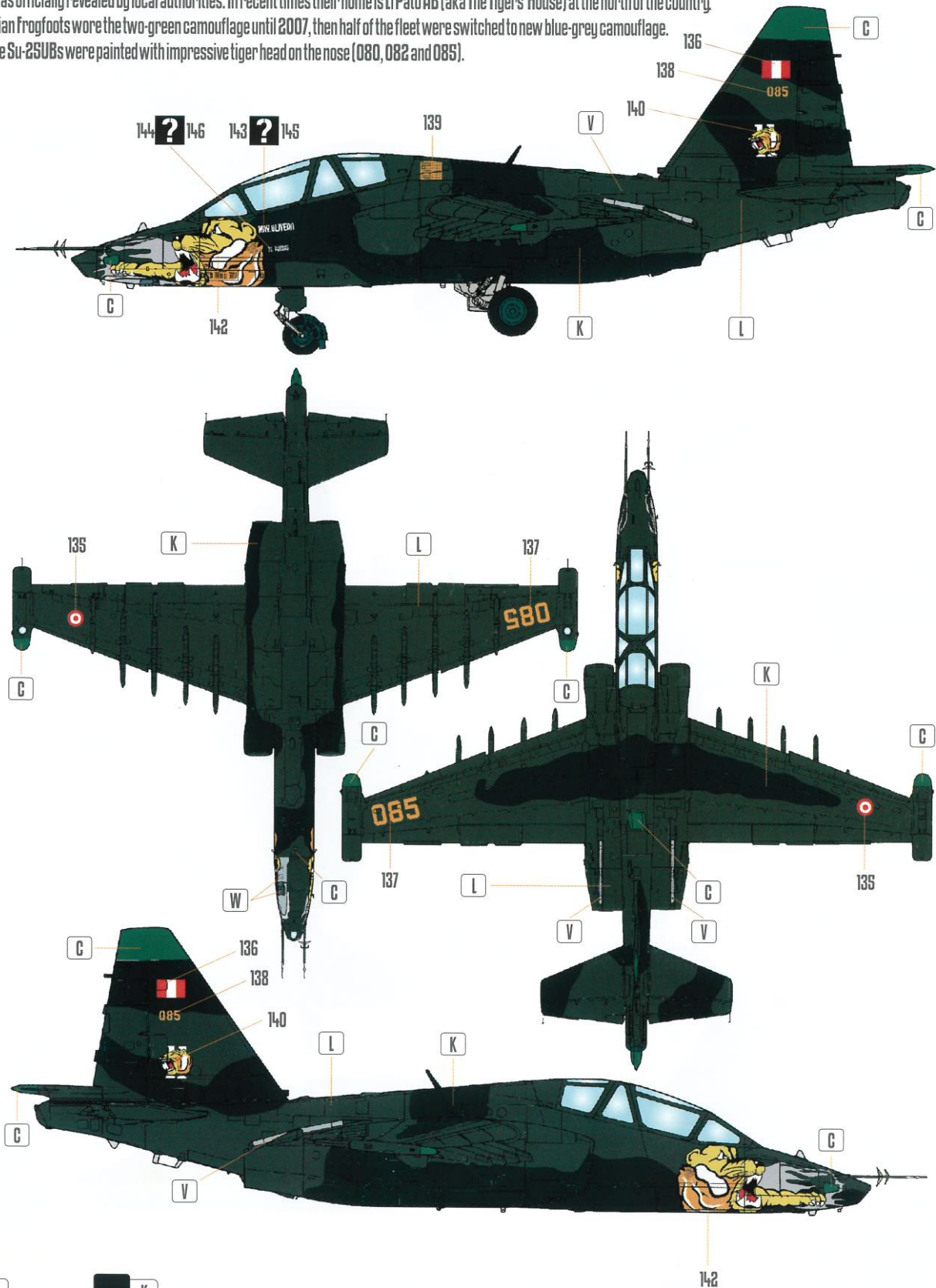

III. Su-25UBK Czechoslovak Air Force 30th Ground Attack Regiment - Pardubice AB, 1992

Two export version of two-seat Su-25 were delivered to former Czechoslovakia on 21st April 1988. After Czechoslovakia peacefully split into the Czech Republic and Slovakia, the 3348 remained in Czech AF inventory, the other UBK 3237 were flown in October 1992 to Slovakia where they formed 1st Flight of 2nd Mixed Air Regiment of 2nd Air Base in Piesany, detached in Trenčín AB. This UBK had white numbers with red outline. The badge of City of Ostrava on the port engine nacelle refers to the titular name of the 30th bilp (Attack Air Regiment) "Ostravsky".

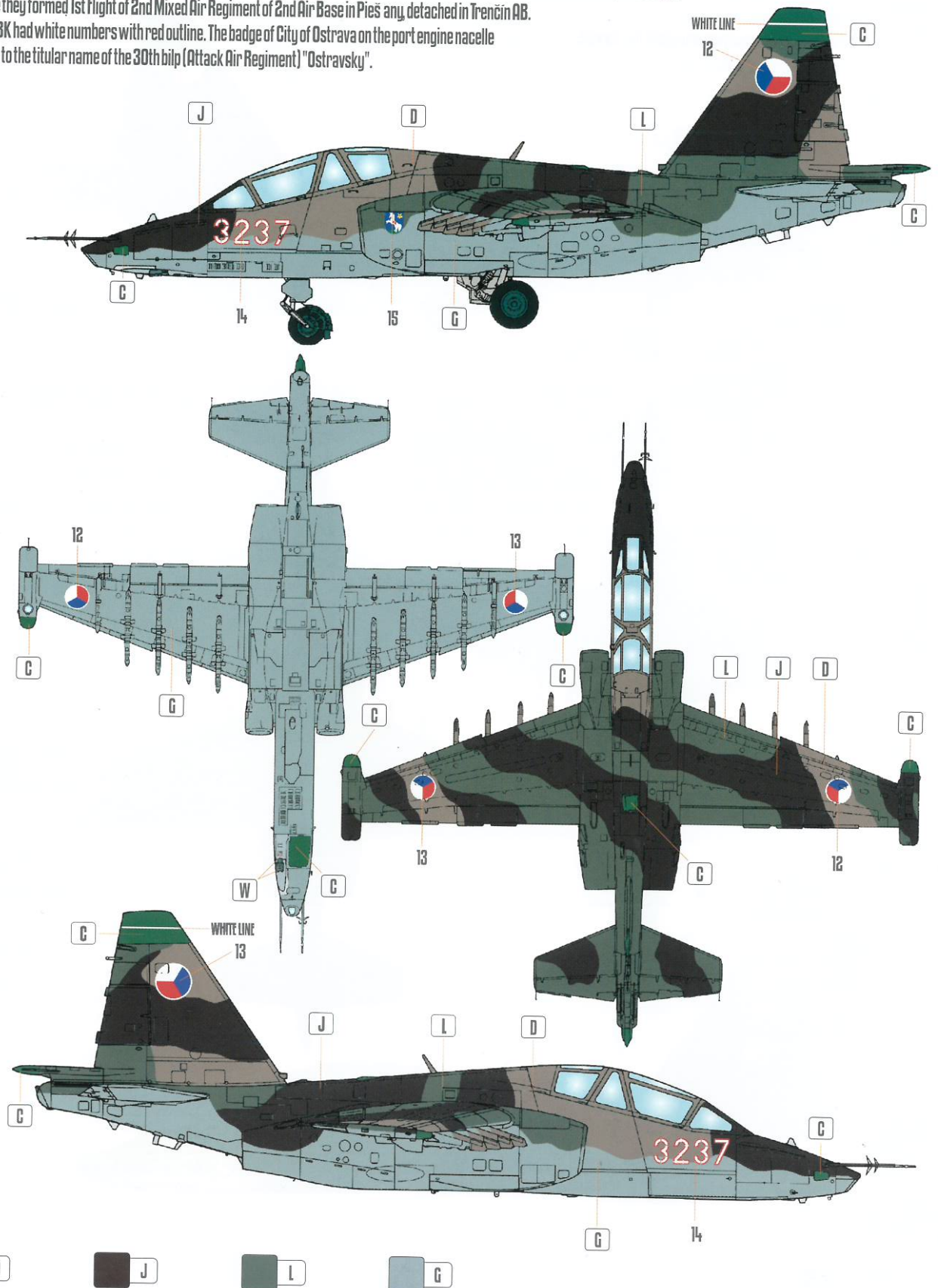

IV. Su-25UB Macedonian Air force

101st Aviation Squadron, Petrovec - Aerodrom Skopje, (aka Alexander the Great airport), 2006

Macedonian Air force acquired four Su-25s from Ukraine during 2001, three of them are single-seaters, and only one UB. They did play significant role in the almost forgotten armed conflict in former Yugoslav republic of Macedonia between ethnic Albanian insurgents and Macedonian army and police. It was decided to withdraw them from use only couple of years after that. At that time they were all in flyable condition with full resources but in accordance with NATO advisors who suggested Macedonia doesn't need close air support aircraft, they were put out of service.

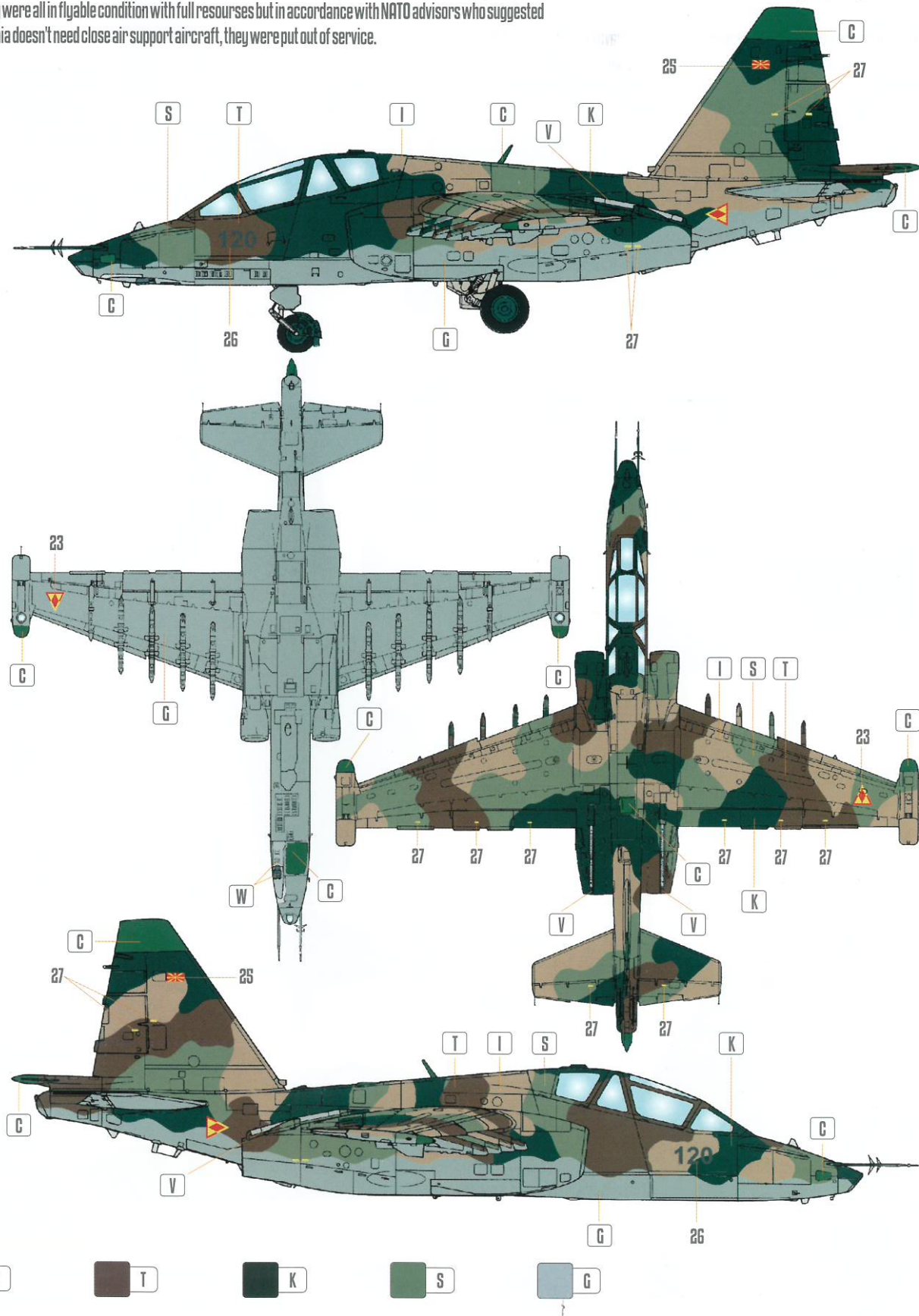

V. Su-25UB Russian Air Force

Red '91' of Chained Dogs squadron, Kubinka, May 1999.

Red '91' was assigned to Chained Dogs (Tsepnih Psov) squadron of 929th Flight Test Center and took part in the first Chechen War (1994-96) or officially called "measures for the maintenance of constitutional order".

The Presidential Palace in Grozny was the primary objective of Russian Su-25s' assault in 1995, however the role of this two-seat Sturmovik in the Chechen war is unknown.

The Red 91 Su-25UB was seen in the 121st Aircraft Repair Factory (ARZ No. 121) at Kubinka in May 1999. She wore the unit artwork on the nose.



VI. Su-25UBK Bulgarian Air Force

22nd Attack Air Base, 2/22 Attack Squadron - Bezmer AB, August 2010

Bulgaria received four two-seat Su-25UBKs during the modernisation of the Bulgarian Air Force (Bulgarski Voenno Vzdushni Sili, BVVS) in '80s. The last MiG-17s were finally retired in 1986 when the 221BAP which was still operating the type was re-equipped with the Su-25 Frogfoot. The aircraft are based at 22nd Attack Airbase Bezmer; due to the fact that the base's revetments were built for the MiG-17, the Su-25s cannot fit inside them and have spent all their lives - 25 years! - sitting outside. Currently there are all four Su-25UBKs flying with the 1/22 Attack Squadron. Bulgaria is the sole operator of the Su-25 in NATO and plans to keep it in service until at least 2012. Bulgarian Su-25s also take part in various joint military exercises such as "Thracian Spring" and "Reunion April" with USAF A-10s from Spangdahlem AB.

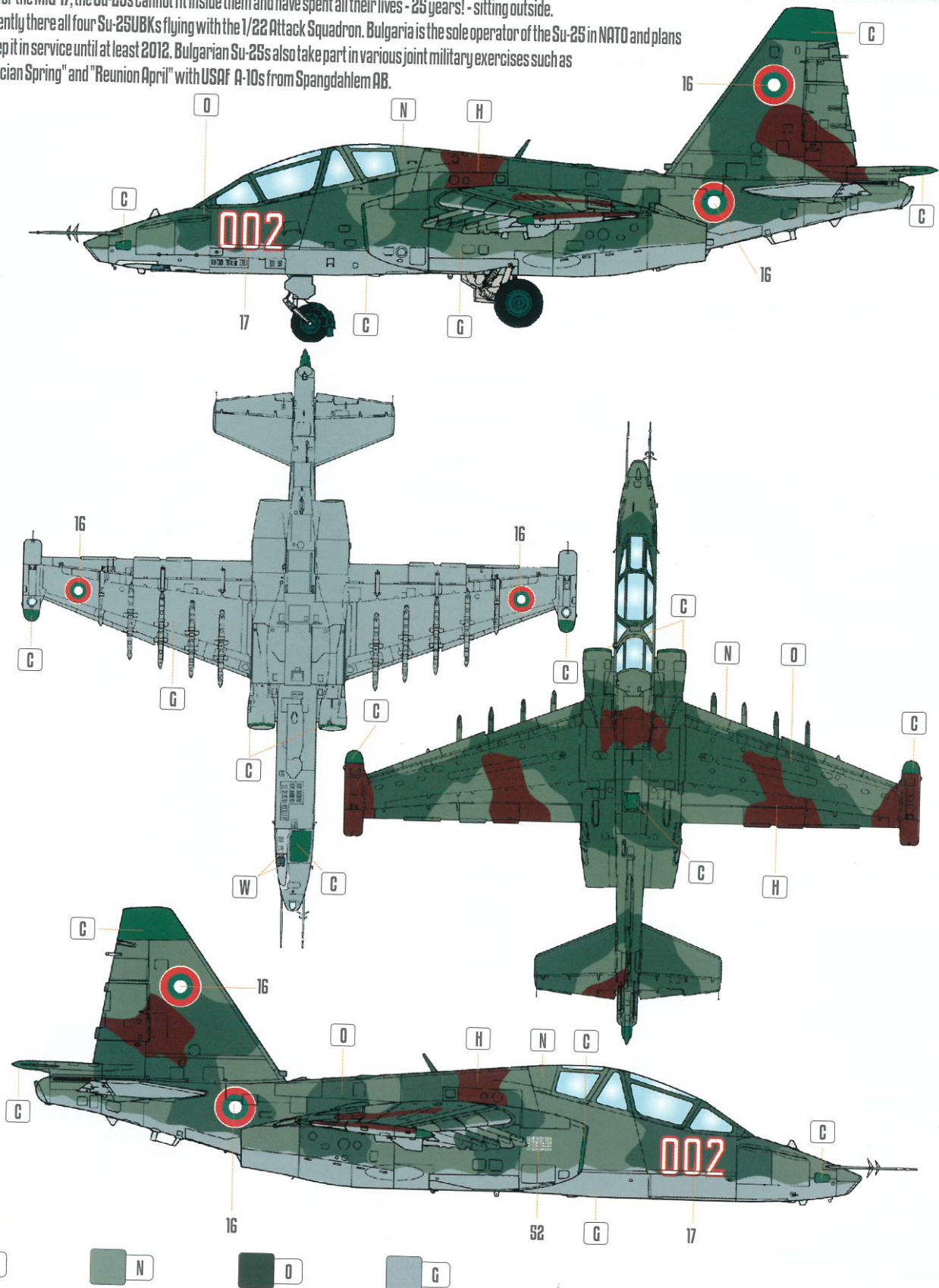

STENCIL DATA

