

1:35 '39-'45 SERIES

# Sd.Kfz.234/1

## Schwerer Panzerspähwagen (2cm)



Project supervised by HIROHISA TAKADA. Technical drawings provided by SHIN OKADA.

KIT NO.6298

**A**

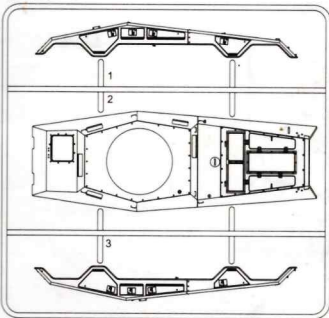

**C**

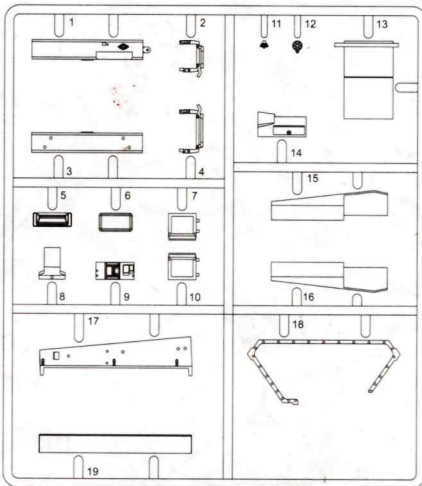

**E**

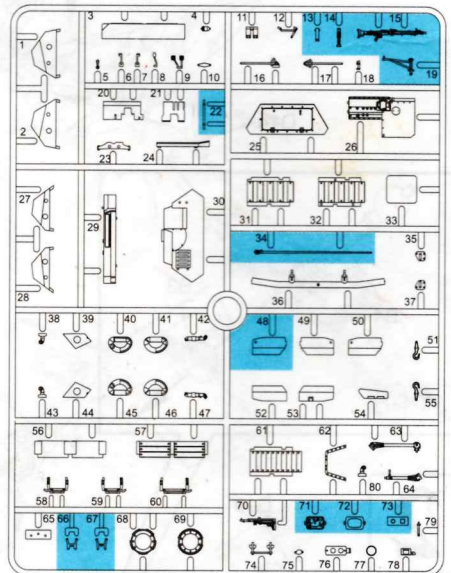

**Bx3**

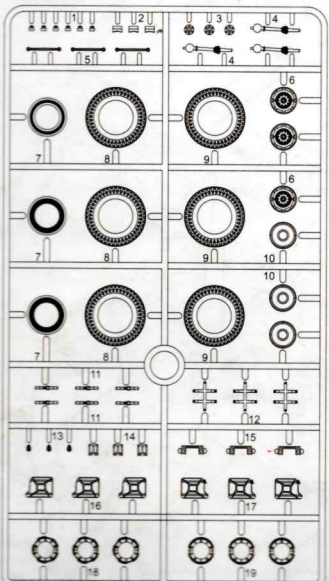

**Dx2**

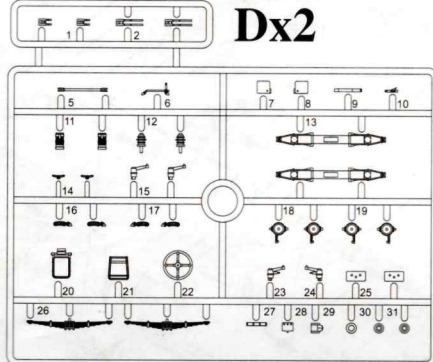

**K**

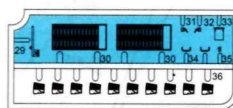

**TG**

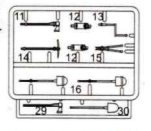

**F**



**G**



**TH**

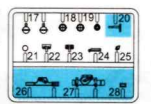

**MA**

(Photo-etched Parts)

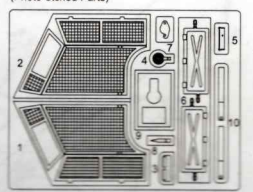

**H**

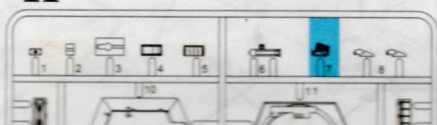

**Wx2**



**MR**





Project supervised by HIROHISA TAKADA. Technical drawings provided by SHIN OKADA.

KIT NO.6298

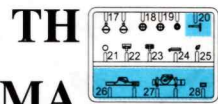
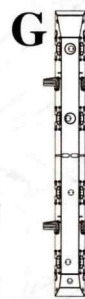
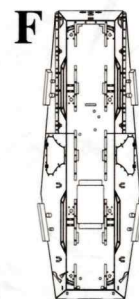
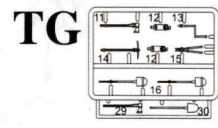
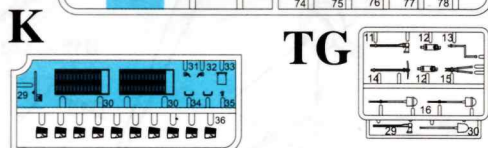
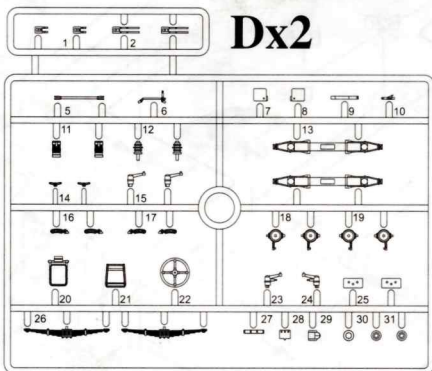
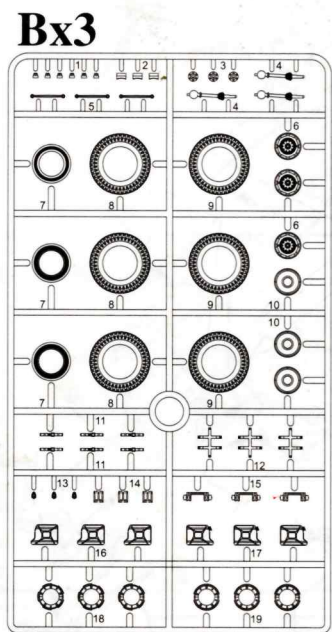
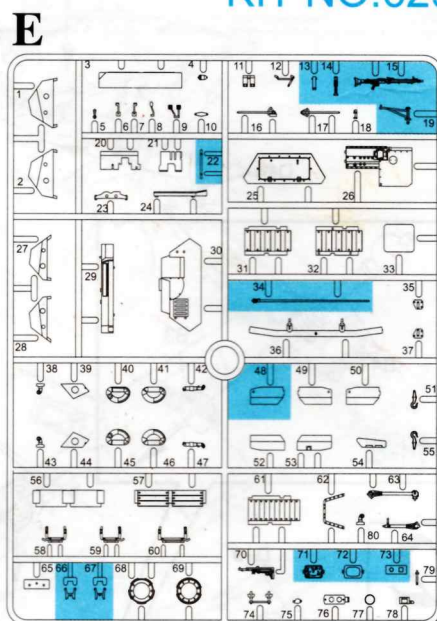
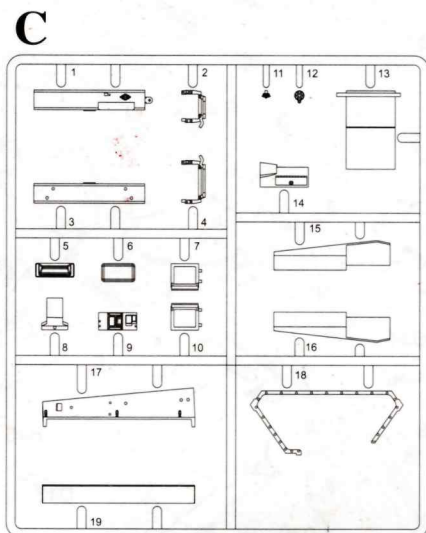
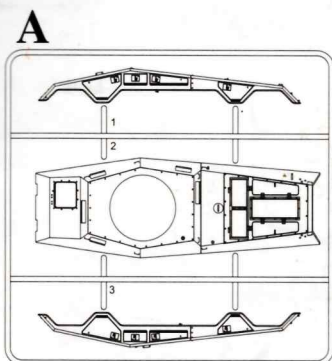

(Photo-etched Parts)

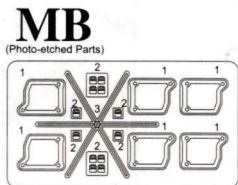
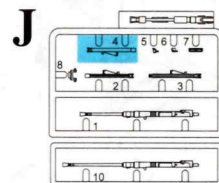
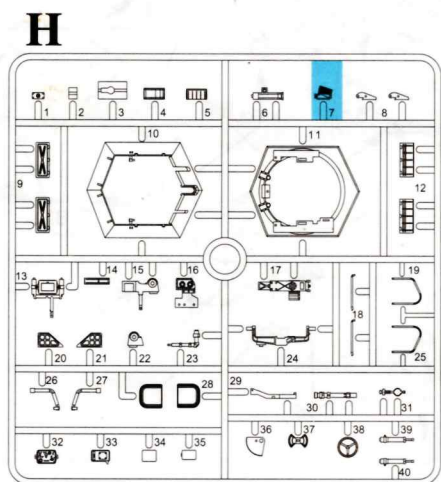
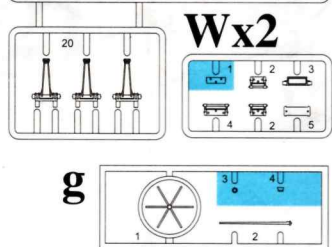
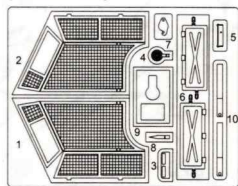

(Photo-etched Parts)

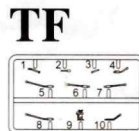
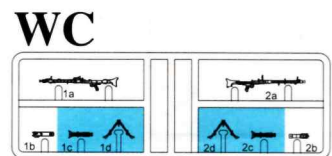

(Metal Parts)

の部品は使用しません  
Parts not for use  
Teile werden nicht verwendet.  
Pieces a ne pas utiliser.  
Parti non utilizzati.  
不要な使用する部品



- 組立ての注意
- 接着剤や塗料は火の、近くで使わないでください。使う時はときどき窓を開けて換気に気を付けましょう。
  - 塗料指定の[1]は GSI CREOS CORP. Mr.カラーの番号です。接着剤や塗料は入っていませんので別にお買い求めください。
  - 部品をランナーから切り離す時は模型用ハサミ等を使い、余分な部分はカッターやヤスリ等で仕上げてください。
  - 組立図のサインマークは下の説明をごらんください。

【注意】

- 勿於近火處使用膠水或油漆，並打開窗戶保持空氣流通。
- [1] 代表 GSI CREOS CORP. 出品 MR.COLOR 的顏色編號。不包括膠水及油漆。
- 自膠架中取出部件時，應用模型專用剪，並用界刀或小銼除去多餘的膠料。
- 各圖型的含意可參考本欄以下的說明。

ZUR BEACHTUNG

- Kleber und Farbe nicht nahe von offenem Feuer verwenden und das Fenster von Zeit zu Zeit zur Belüftung öffnen.
- Der [1] der Farb Kennzeichnung bedeutet die Farbnummer von GSI CREOS CORP. MR. COLOR. Kleber und Farbe sind nicht enthalten.
- Zum Abschneiden der Teile vom Verbundstück eine Modellierschere verwenden und die überstehenden Plastikteile mit einem Messer oder einer Feile beseitigen.
- Die Bedeutung der Symbols finden Sie unten in dieser Spalte.

CAUTION

- When you use glue or paint, do not use near a naked flame, and use in a well-ventilated room.
- Symbols such as [1] refer to the color number of GSI CREOS CORPS. MR. COLOR. Glue and paint are not included.
- When you take parts off the runner frame, use modeling scissors and trim excess plastic with a cutter or a file.
- See below for the meaning of symbols.

ATTENTION

- Ne pas utiliser de colle ou de peinture a proximite d'une flamme nue, et aérer la pièce de temps en temps.
- Le numéro [1] pour l'indication de couleurs correspond au numéro de GSI CREOS CORP. MR. COLOR. La colle et la peinture ne sont pas comprises.
- Pour retirer les pièces hors du cadre, utiliser des ciseaux spéciaux pour maquette le plastique en excès avec un cutter ou une lime.
- Voir la fin de cette colonne pour la signification des symboles

ATTENZIONE

- Non usare colla a vernice vicino a fiamme esposte, e aprire le finestre di tanto in tanto per cambiare l'aria.
- [1] delle indicazioni di colore si riferisce al numero di colore di GSI CREOS CORP. MR. COLOR. Colla e vernice non sono incluse.
- Quando si staccano parti del carrello, usare forbici da modellismo e eliminare la plastica in eccesso con un coltello o una lima.
- Vedere in fondo a questa colonna per il significato dei simboli.

2 コツくってください MAKE 2PCS EFFECTUER 2 PIECES FARE DUE PEZZI TEE 2 KPL GOR 2 ST 製作二組	切り取ってください REMOVE ENTFERNEN RETIRER SEPARARE POISTA AVLAGSNA 除去	接着しないでください DO NOT CEMENT NICHT KLEBEN NE PAS COLLER NON INCOLLARE EIJLIMAA LIMMAEJ 不用貼合	テールを付けてください APPLY DECAL HIER ABZIEHBLD APPLIQUER DECALOMANIE APPLICARE DECALOMANIE ASETA SIIRTOKUVA APPLICERA DECALEN 貼上水印紙	穴をうめてください FILL HOLE SCHLIESSEN BOUCHER LE TROU FORD PIENO TAYTA REIKA FYLL HÅLET 把孔填平	接着剤が乾くまで 2-3 分待ちます。 PLEASE WAIT FOR A FEW MINUTES UNTIL DRY ENGJE MINUTEN WARTEN BIS DER KLEBSTOFF GETROCKNET IST ASPECTARE ALCUNI MINUTI FINCHE LA COLLA SI E ASSOGATA VEUILLEZ PREVENTER QUELES JUSQU'AU SECHAGE VAITA NAGRA MINUTET TILLS TORP ODOTA MUUTAMA MINUUTTI KUUNES KUUVANUT 稍候數分鐘 直至接著劑乾固
注意してください BE CAREFUL HIER VORSICHT FAIRE ATTENTION USARE ATTENZIONE VAROASTI FORIKTIGT 小心留意	穴をゆけてください OPEN HOLE OFFNEN FAIRE UN TROU FORO APERTO AVAA REIKA OPPNA HÅLET 鑽孔	接着してください CEMENT TOGETHER ZUSAMMENKLEBEN COLLER ENSEMBLE INCOLLARE INSIEME LIMMA YHTIEN LIMMA IHOP 用膠貼合	折り曲げてください BEND BITTE BIEGEN PLIER S'IL VOUS PLAÎT PIEGARE TÄITA BOCKA 屈曲	どちらかを選んでください OPTIONAL NACH BELIEBEN FACULTATIF FACOLTATIVO VALINNANVARAINEN VALBAR 可以選擇採用	瞬間接着剤 (金屬用) INSTANT GLUE FOR METAL METALLKLEBER COLLA A METAL INSTANTANEE COLLA INSTANTANEA PER METALU PIKALIMAA METALLIOSIA VARTEN SNABBIM FÖR METALLDELAR 金屬用速乾膠

H1 GSI CREOS CORP. AQUEOUS HOBBY COLOUR MODEL MASTER COLOR *Hom* 1 GSI CREOS CORP. MR. COLOUR

H 8 8	シルバー	1546	SILVER	SILBER	ARGENT	ARGENTO	銀色
H 9 9	ゴールド	1744	GOLD	GOLD	OR	ORO	金色
H 11 62	つや消しホワイト	1768	FLAT WHITE	MATTWEISS	BLANC MAT	BLANCO OPACO	啞白色
H 12 63	つや消しブラック	1749	FLAT BLACK	MATTSCHWARZ	NOIR MAT	NERO OPACO	啞黑色
H 18 28	黒鐵色	1415	STEEL	STAHL	ACIER	ACCIAIO	黒鐵色
H 37 43	ウッドブラウン	1735	WOOD BROWN	HOLZBARAUN	BRUN BOIS	MARRONE LEGNO	木棕色
H 48 52	オリブグレー(ワルドグレー(2))	1723	FIELD GRAY(2)	FELDGRAU(2)	GRIS DES TROUPES ALLEMANDES(2)	VERDE CAMPO	田灰色(2)
H 76 61	焼鐵色	1406	BURNED IRON	GBER, EISEN	FER BRULE	FERRO BRUCIATO	燒鐵色
H 80 64	カーキグリーン	1710	KHAKI GREEN	KHAKIGRÜN	VERT KHAKI	VERDE KAKI	砒礫綠色
H 430	ダークイエロー	2099	DARK YELLOW	DUNKEL GELB	JAUNÉ FONCÉ	GIALLO SCURO	暗黃色

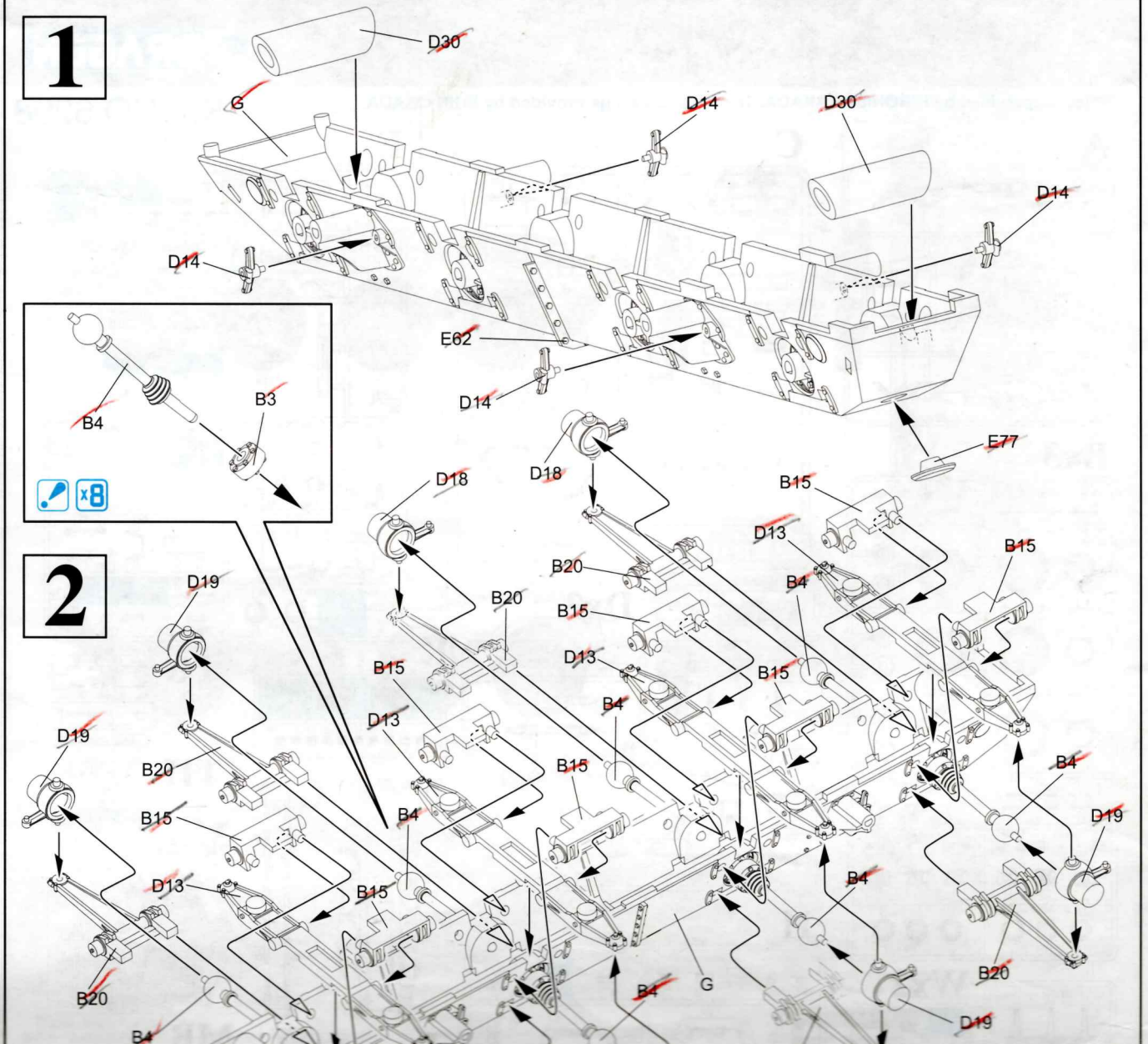



**H1** GSI CREOS CORP. AQUEOUS HOBBY COLOUR **1** GSI CREOS CORP. MR. COLOUR  
**MODEL MASTER COLOR** *Tom*

H 8 8	シルバー	1546	SILVER	SILBER	ARGENT	ARGENTO	銀色
H 9 9	ゴールド	1744	GOLD	GOLD	OR	ORO	金色
H 11 62	つや消しホワイト	1768	FLAT WHITE	MATTWEISS	BLANC MAT	BLANCO OPACO	啞白色
H 12 63	つや消しブラック	1749	FLAT BLACK	MATTSCHWARZ	NOIR MAT	NERO OPACO	啞黑色
H 18 28	黒鐵色	1415	STEEL	STAHL	ACIER	ACCIAIO	黒鐵色
H 37 73	ウッドブラウン	1735	WOOD BROWN <i>F6u</i>	HOLZBARAUN	BRUN BOIS	MARRONE LEGNO	木棕色
H 48 62	オリブグレー(フィールドグレー(2))	1723	FIELD GRAY(2)	FELDGRAU(2)	GRIS DES TROUPES ALLEMANDES(2)	VERDE CAMPO	田灰色(2)
H 76 61	焼鐵色	1406	BURNT IRON	GEBR. EISEN	FER BRULE	FERRO BRUCIATO	焼鐵色
H 80 64	カーキグリーン	1710	KHAKI GREEN <i>F61</i>	KHAKIGRÜN	VERT KHAKI	VERDE KAKI	砒礫綠色
H 430	ダークイエロー	2099	DARK YELLOW <i>F60</i>	DUNKEL GELB	JAUNÉ FONCÉ	GIALLO SCURO	暗黃色

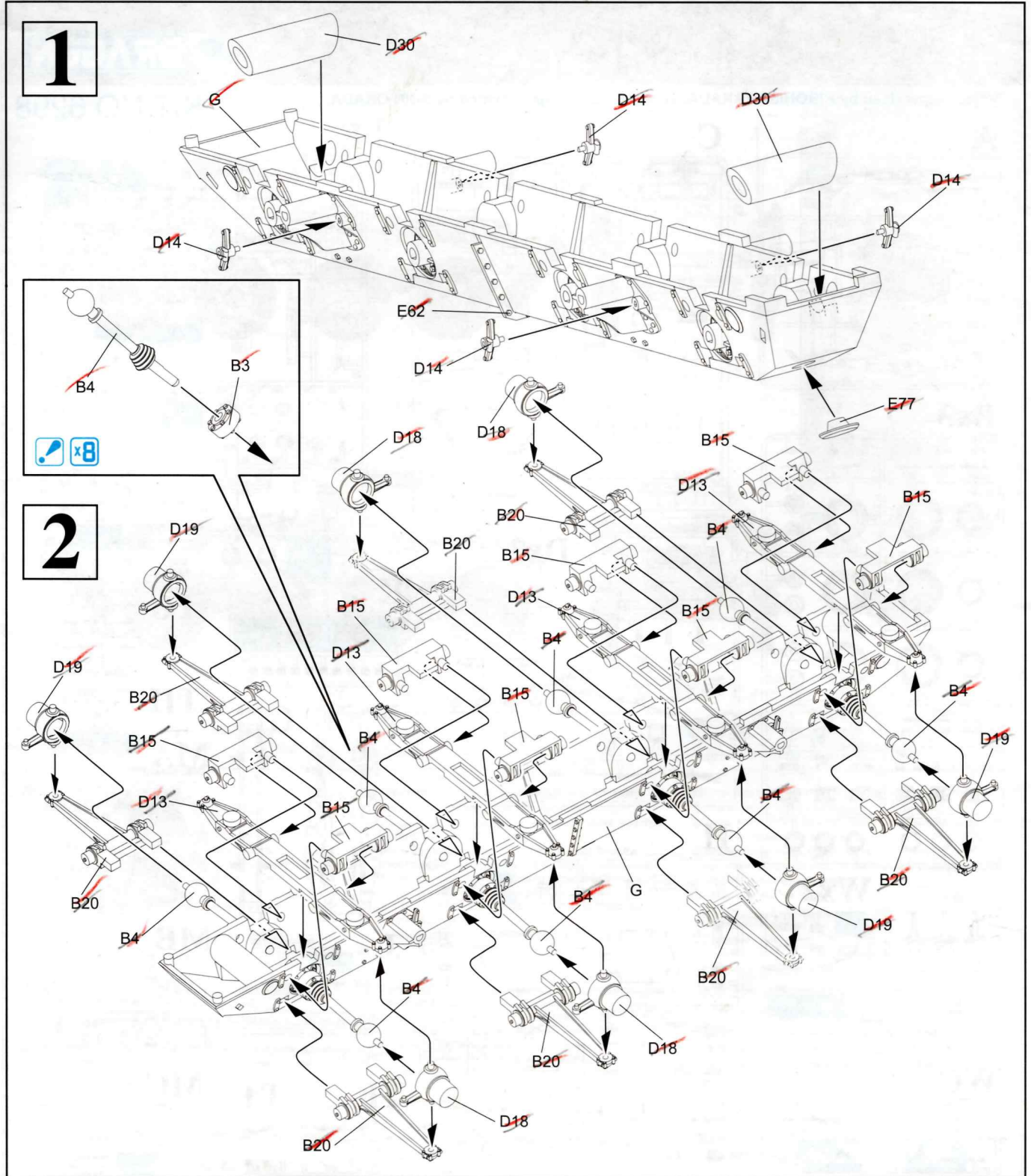



3

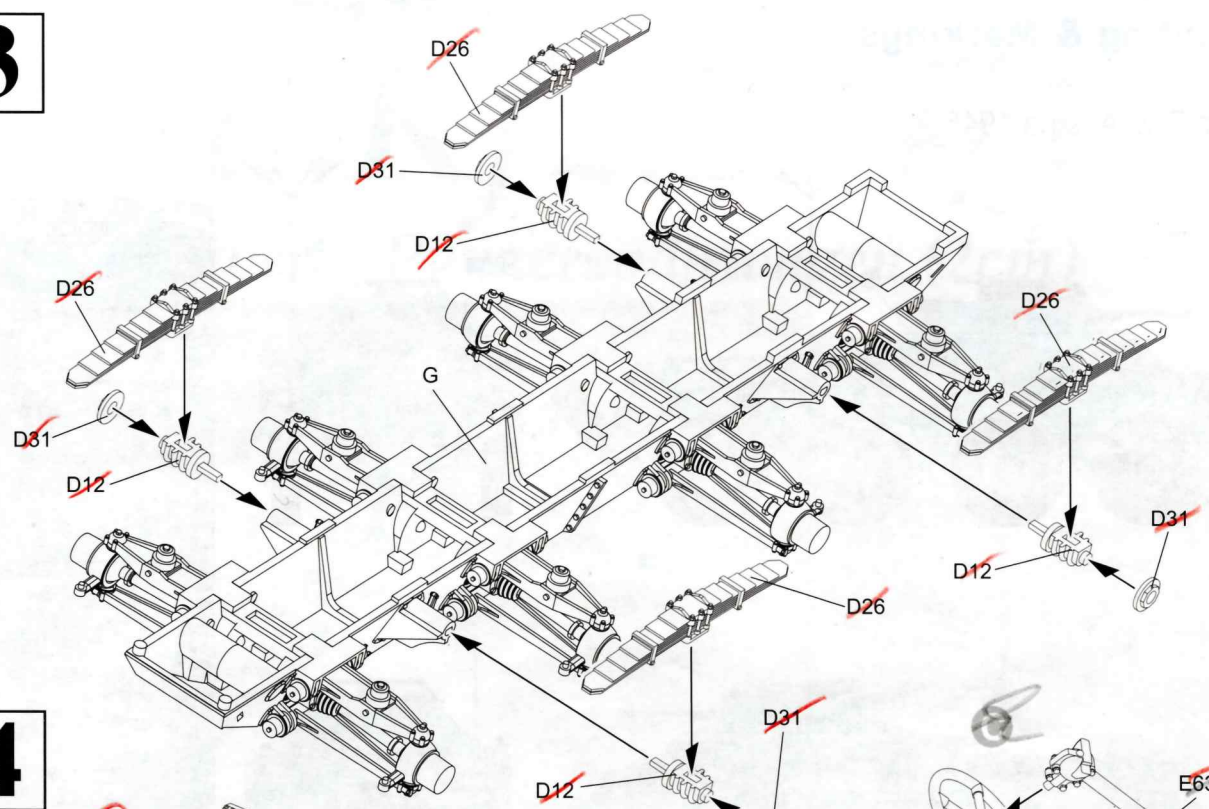

4

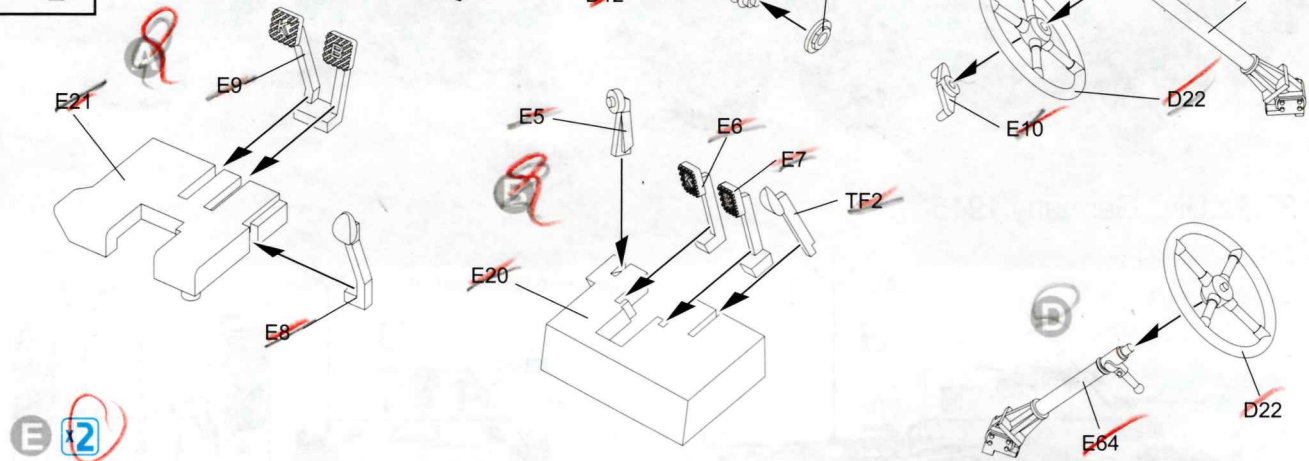

E 12

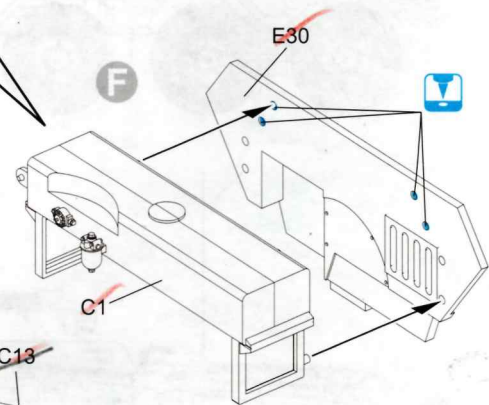
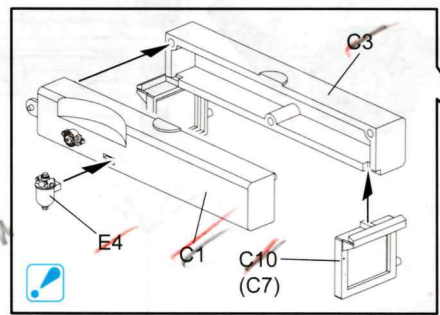
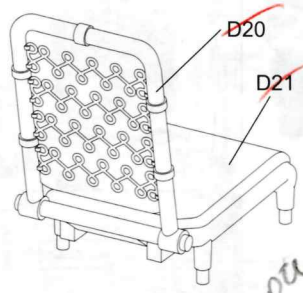

5

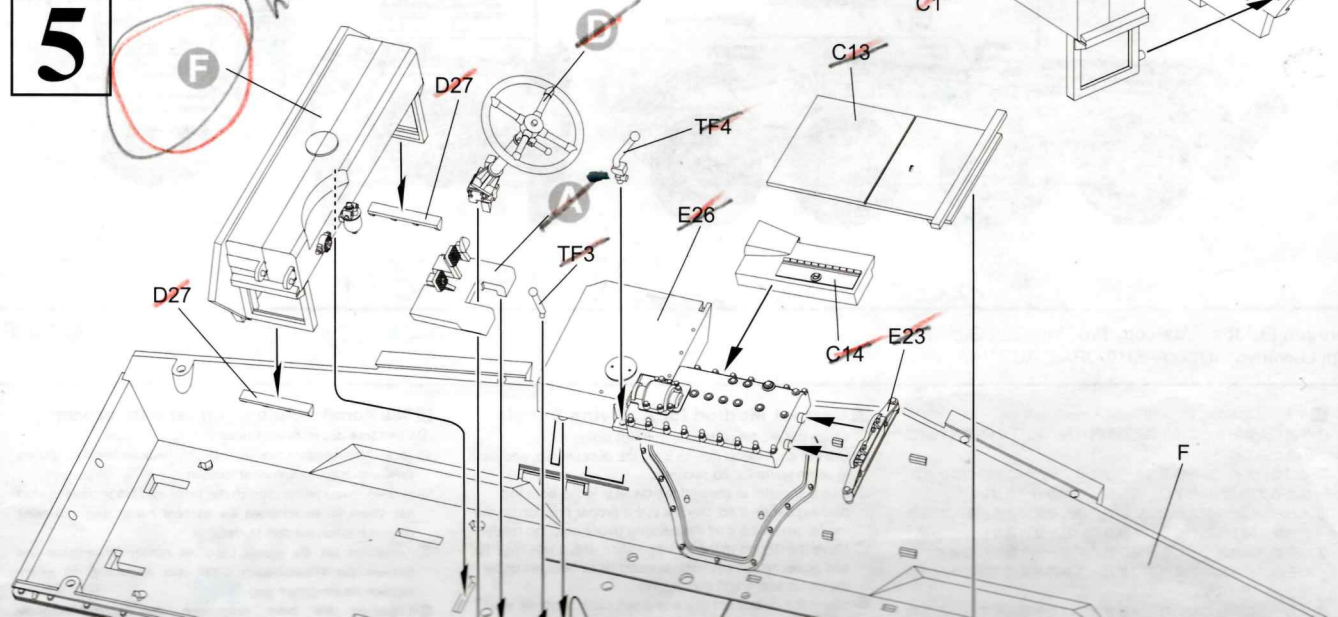



4

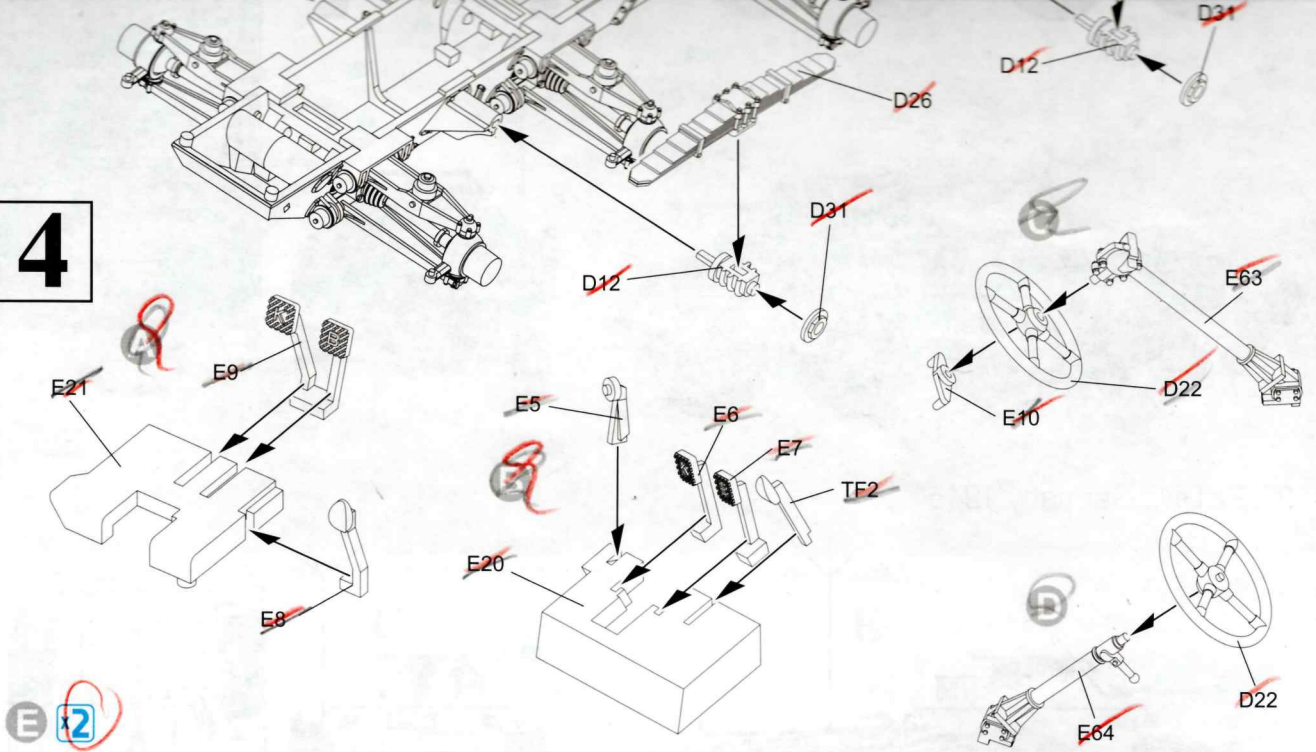

E 2

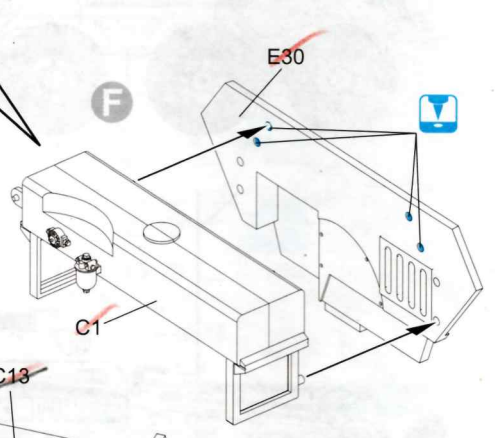
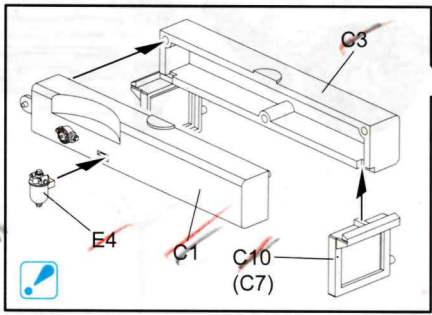
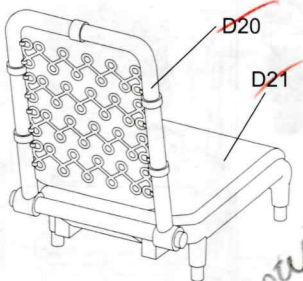

5

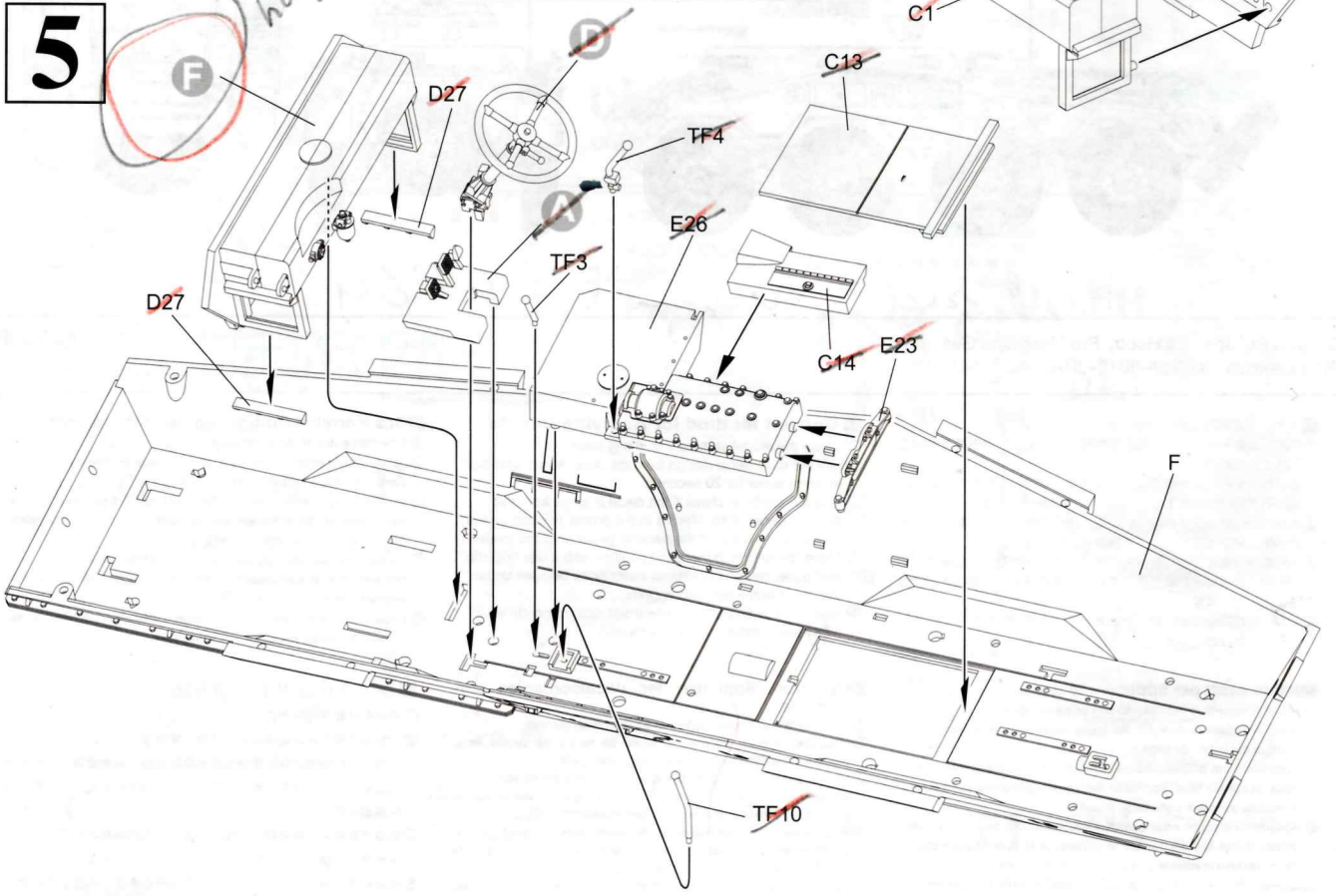



6

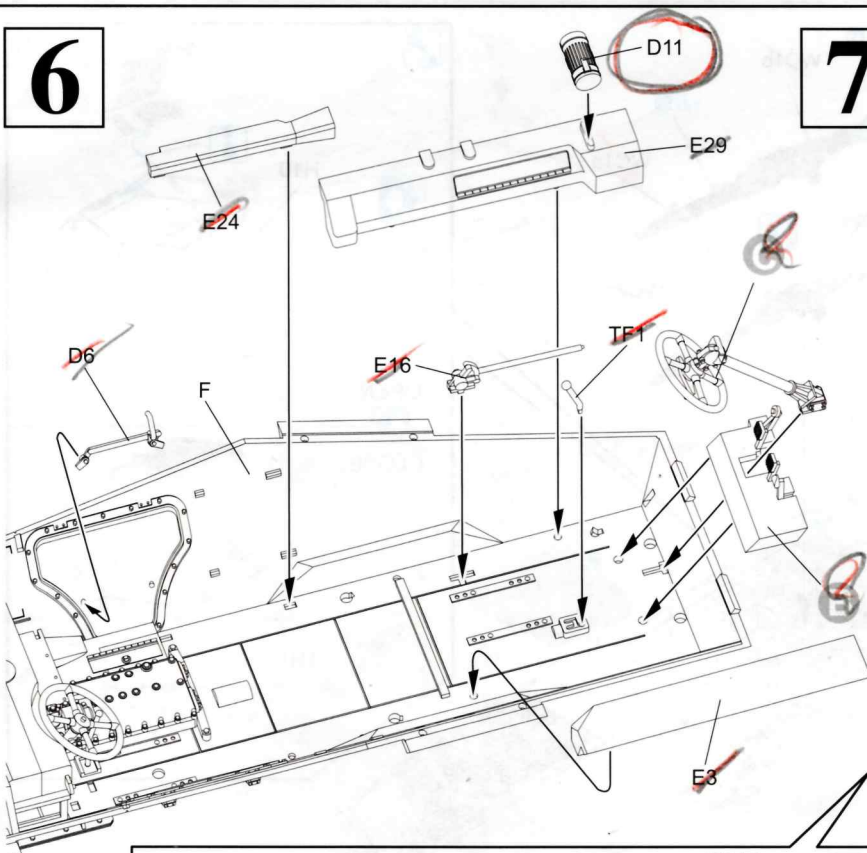

7

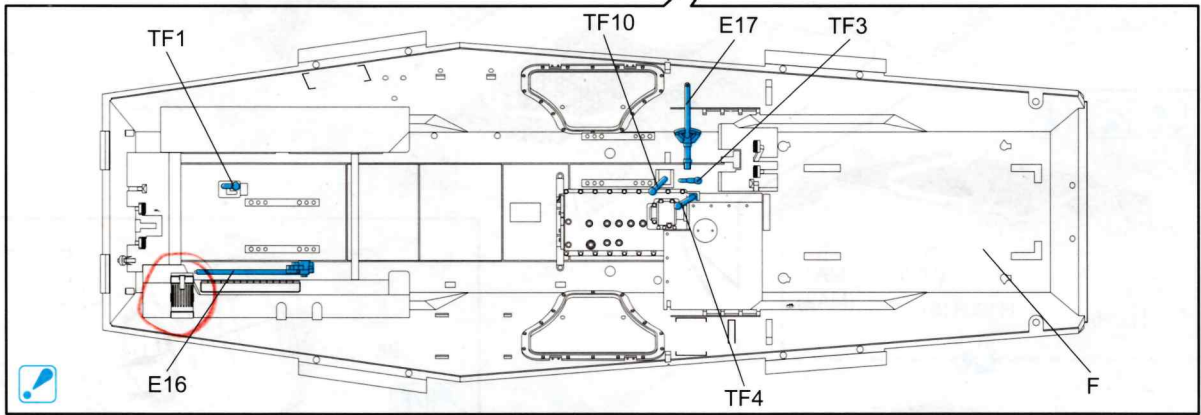
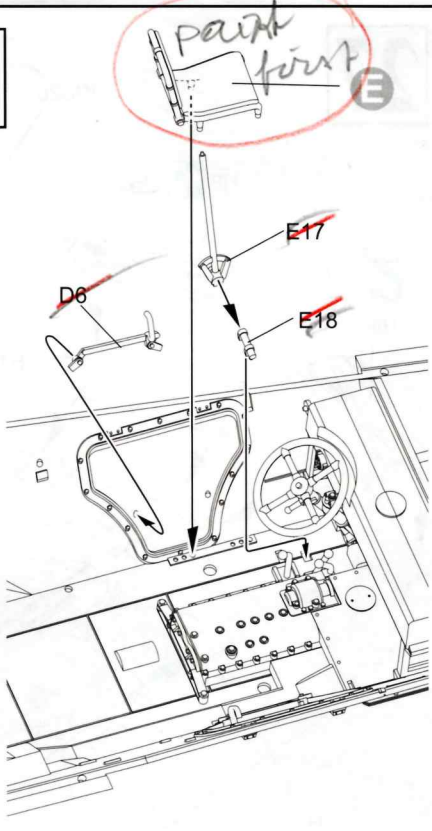

8

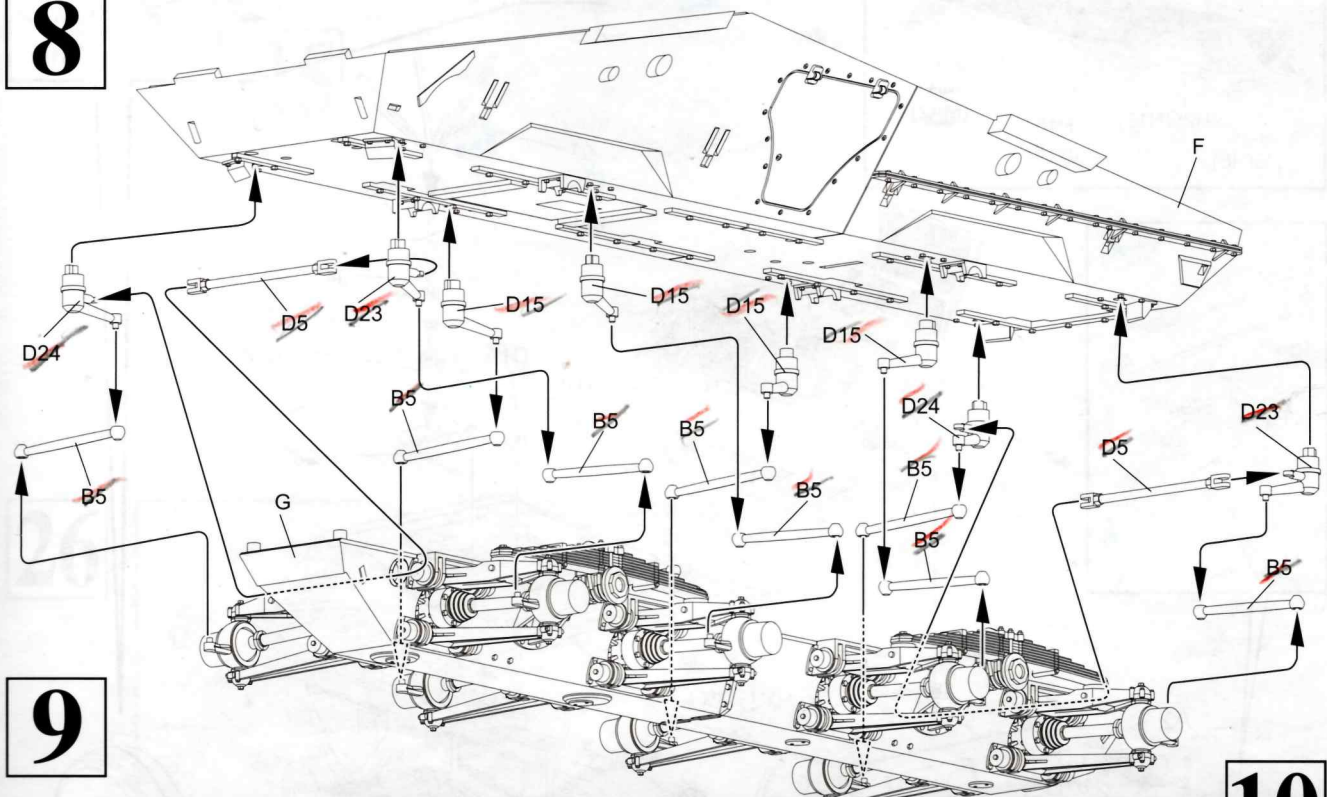

9

10









# 11

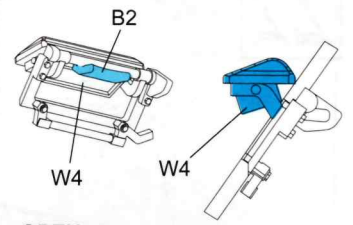
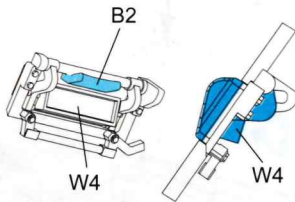
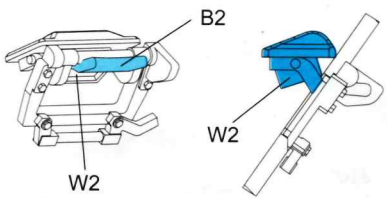

OPEN  
CLOSE

CLOSE  
OPEN

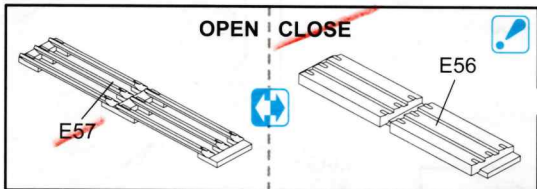
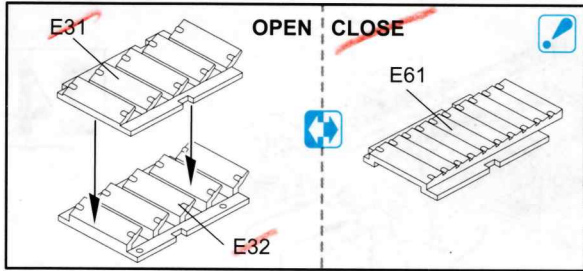
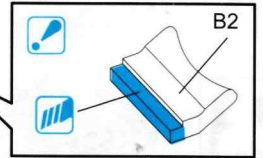
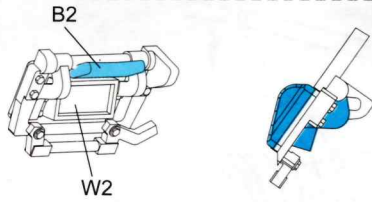

# 12

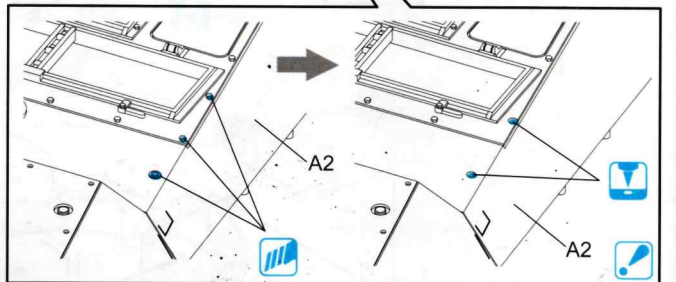
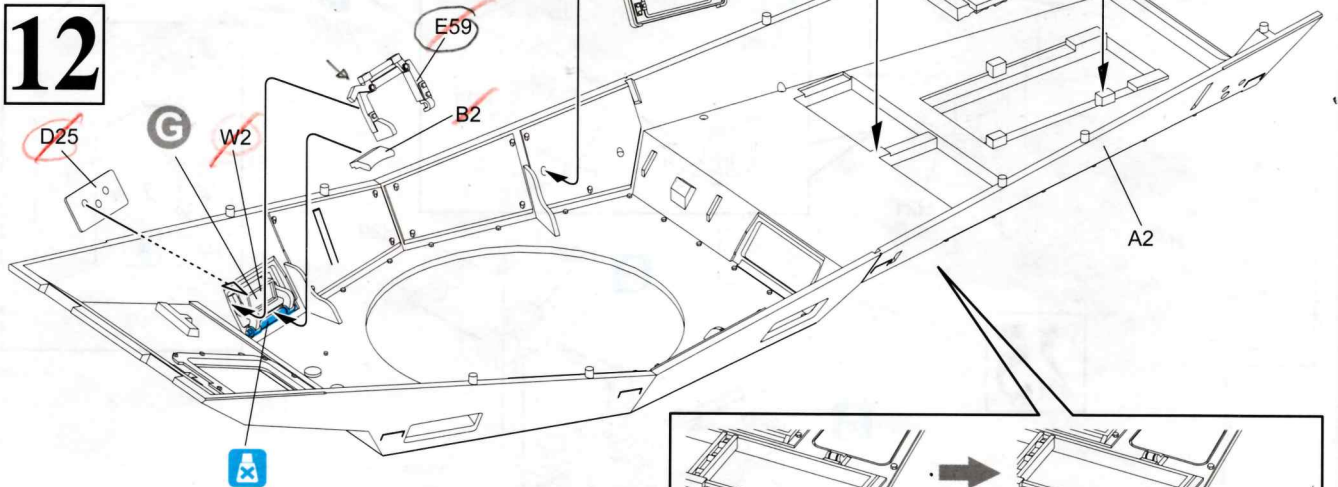

# 13

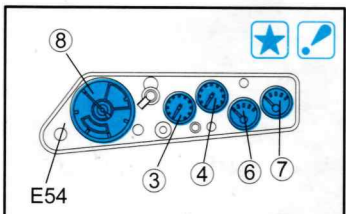

# 14

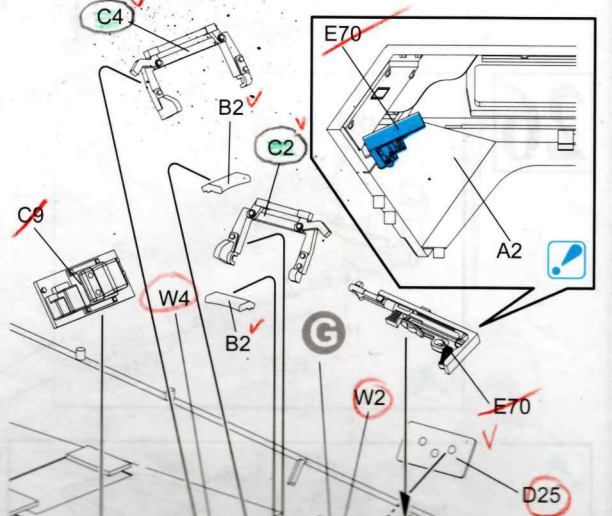
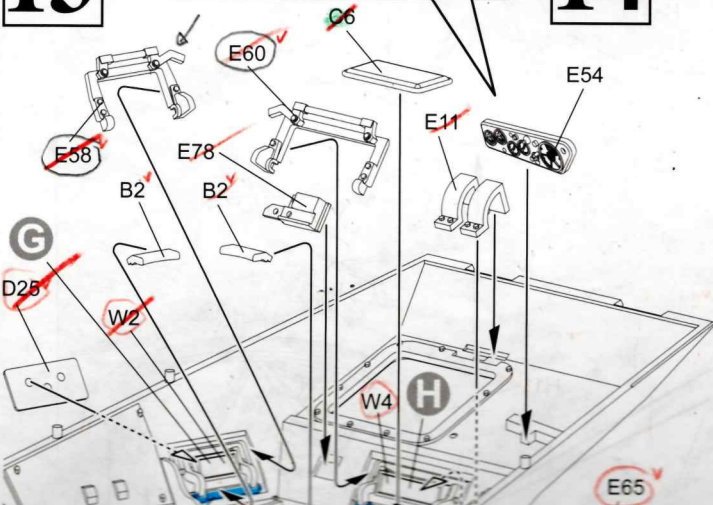



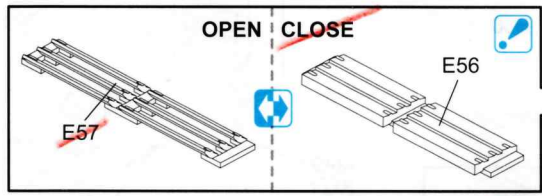
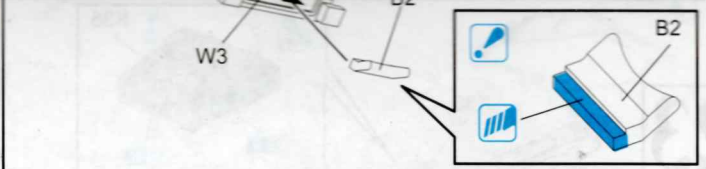
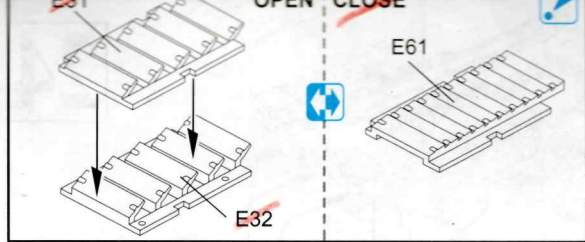

**12**

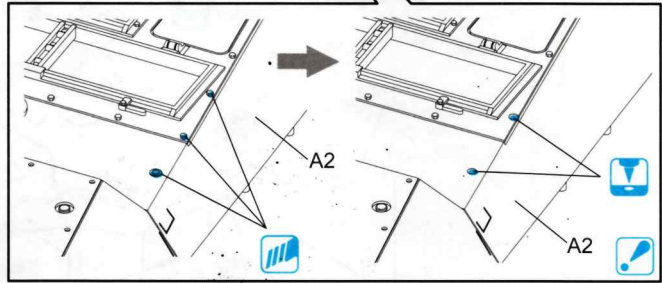
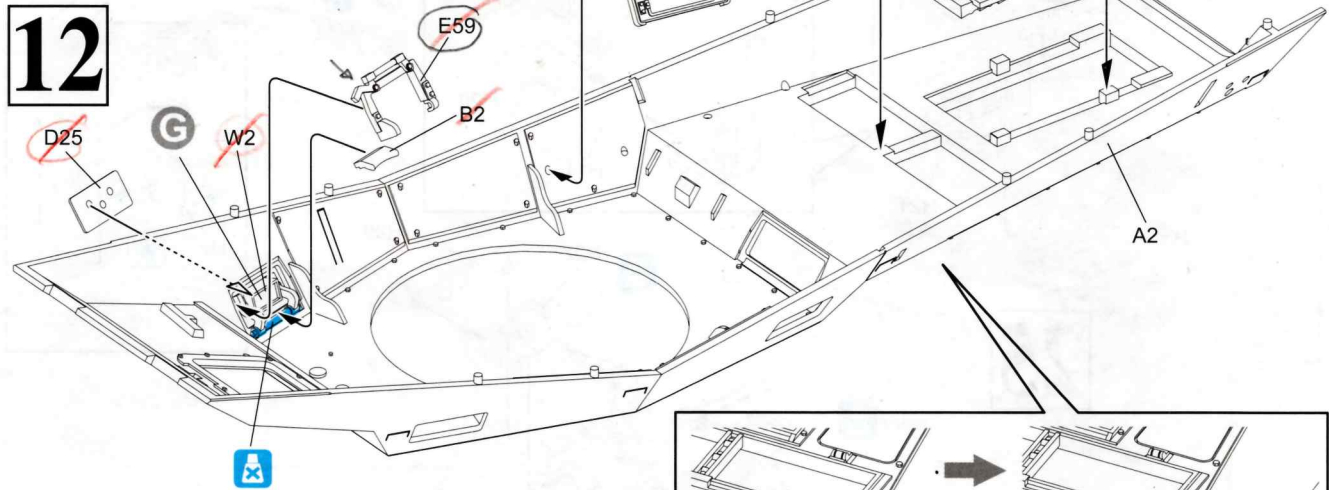

**13**

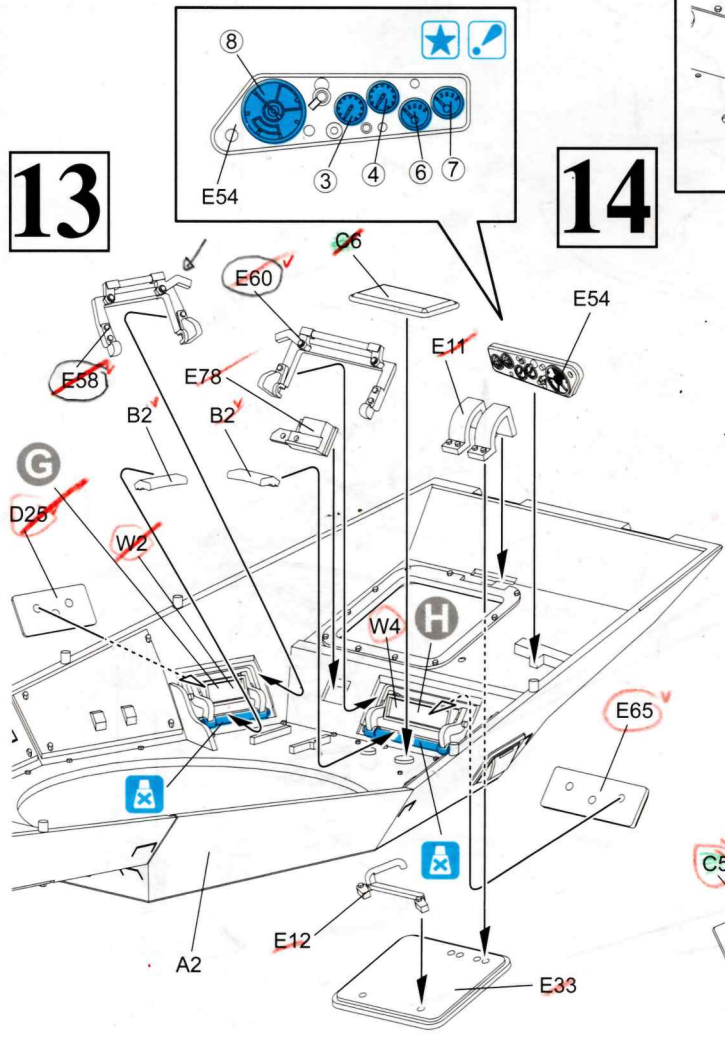

**14**

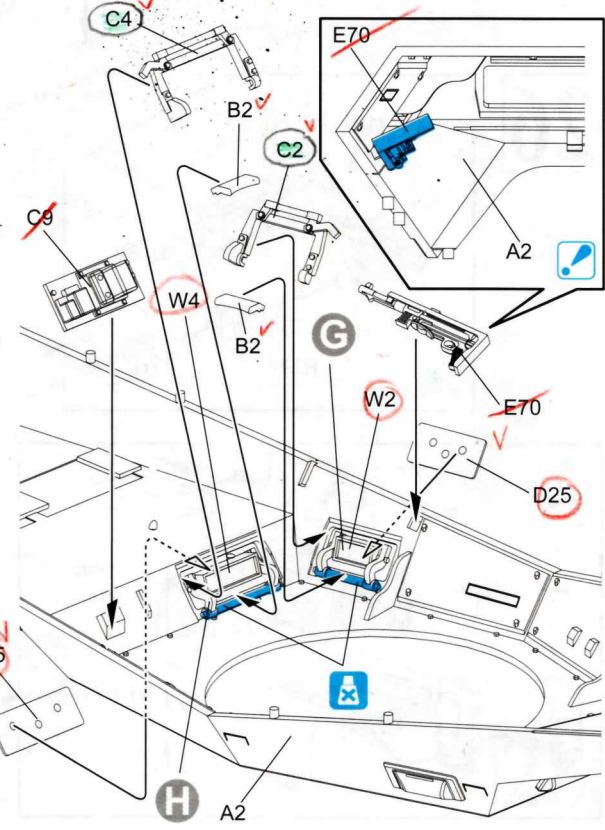



15

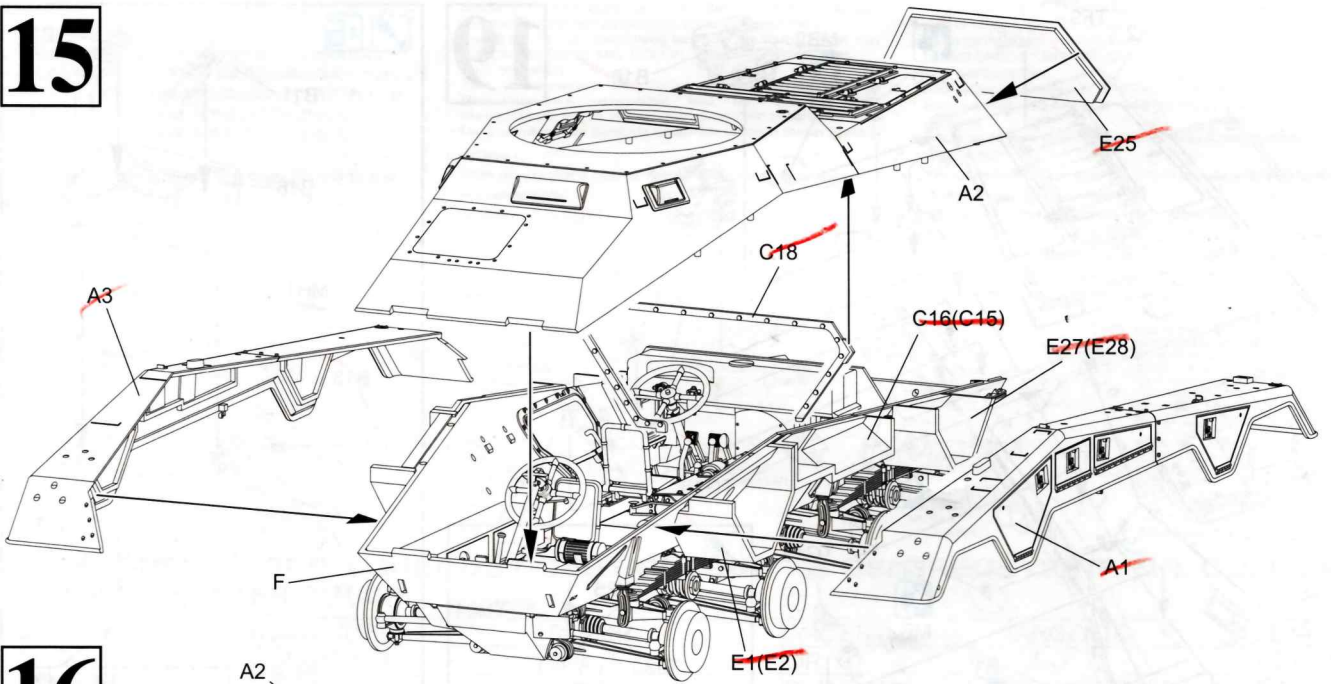

16

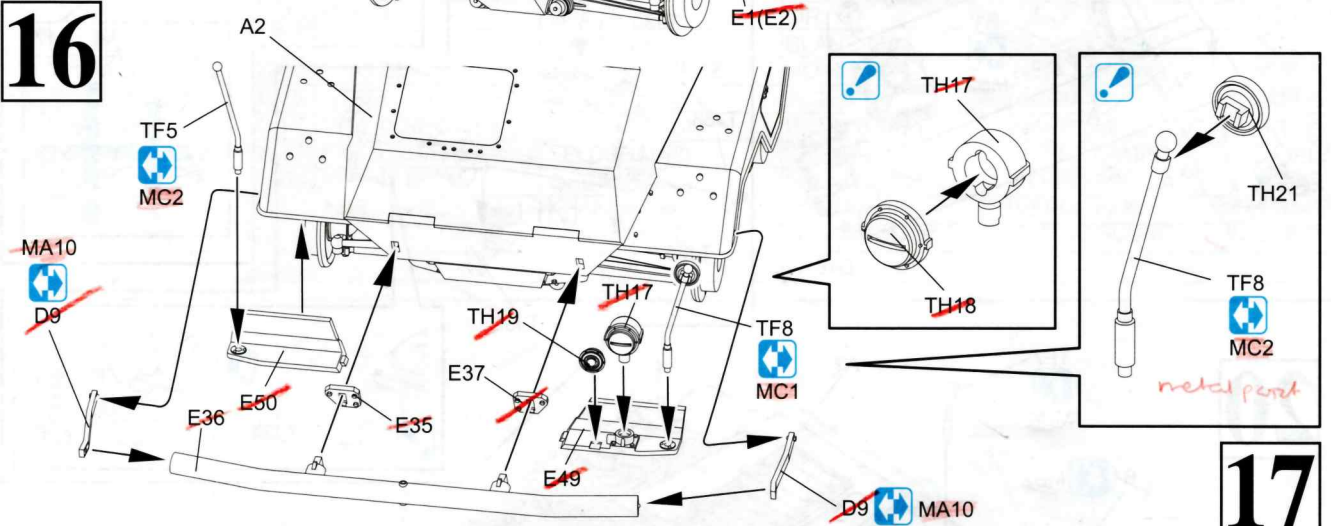

17

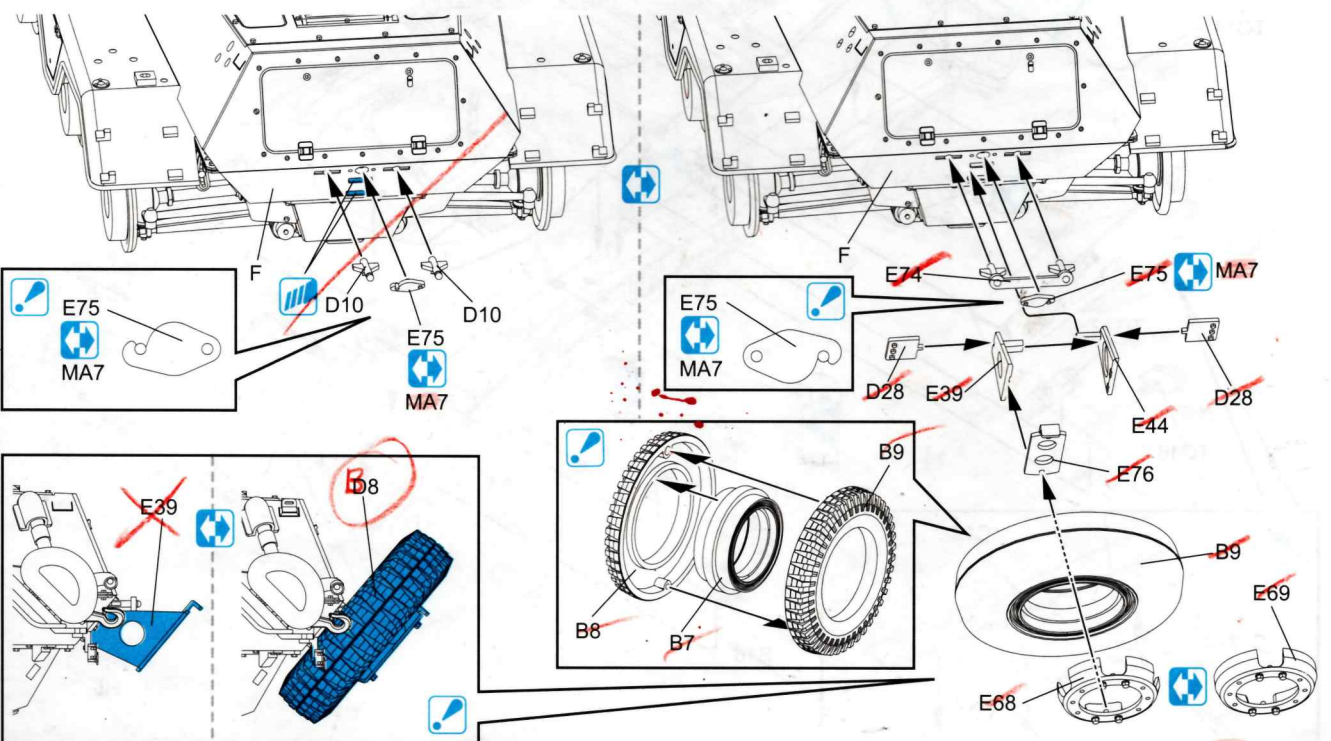

18

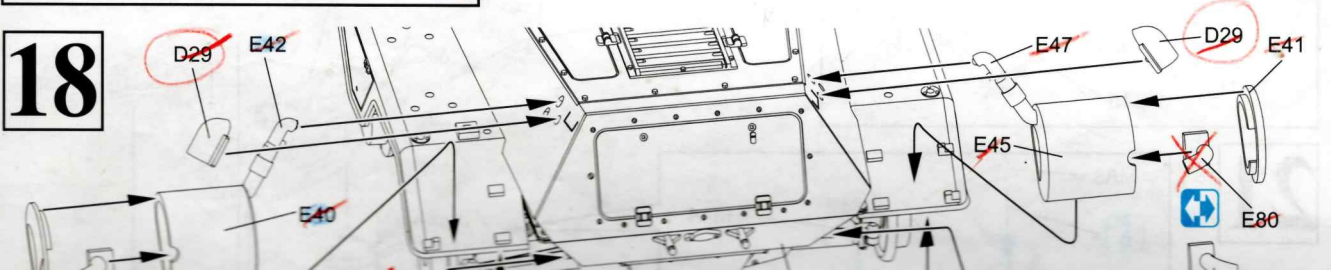



16

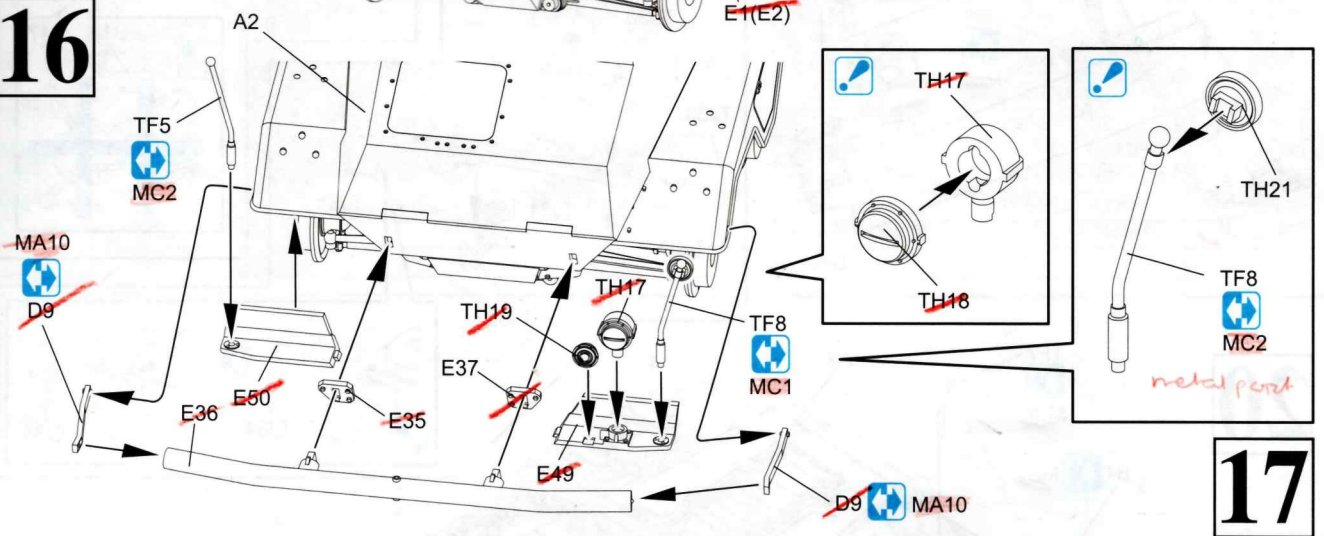

17

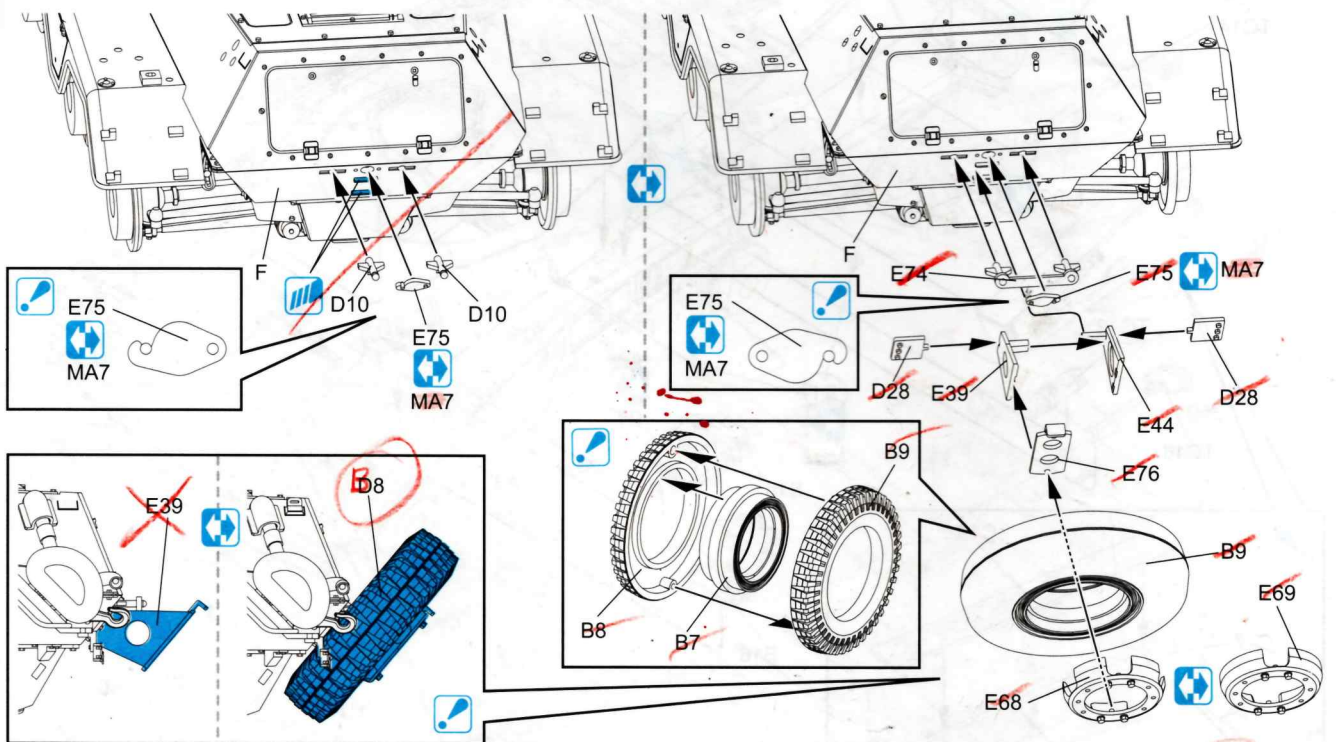

18

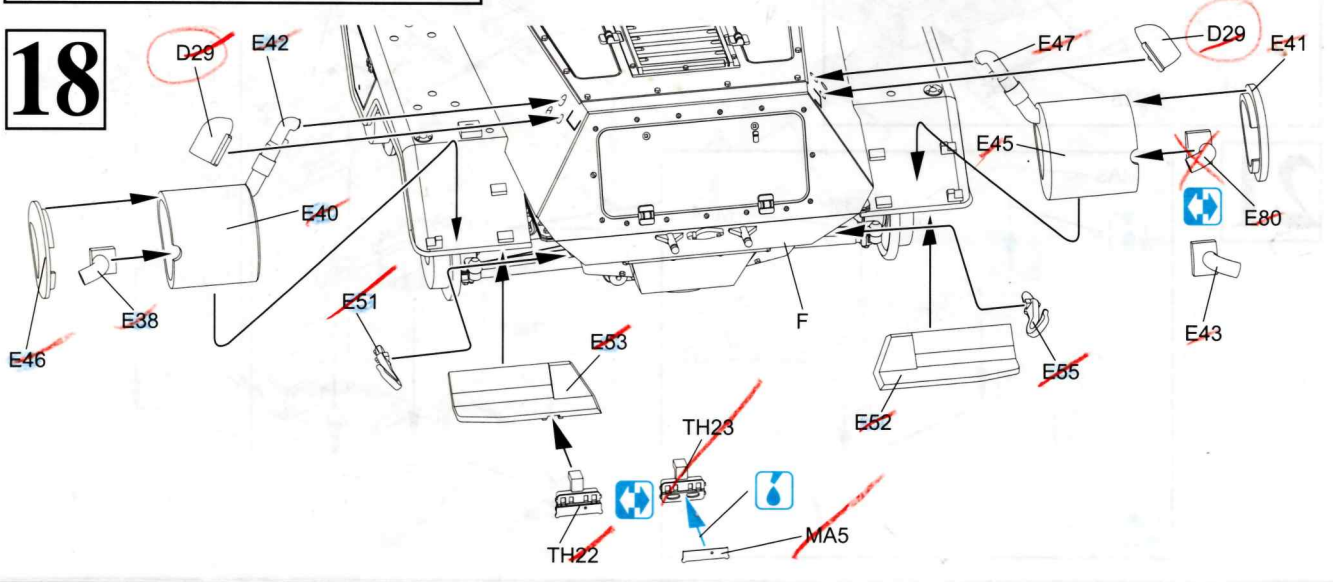



# 19

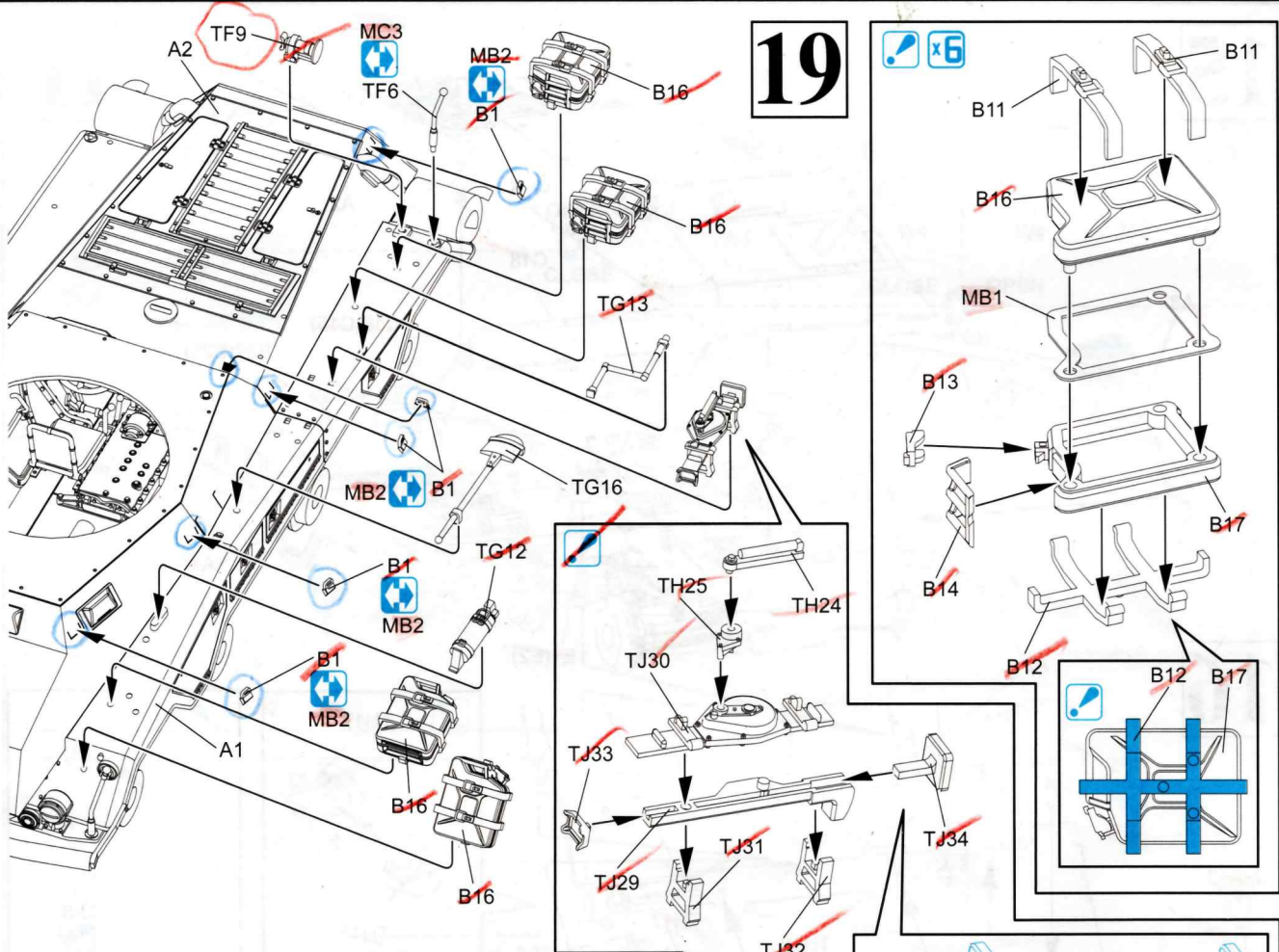

# 20

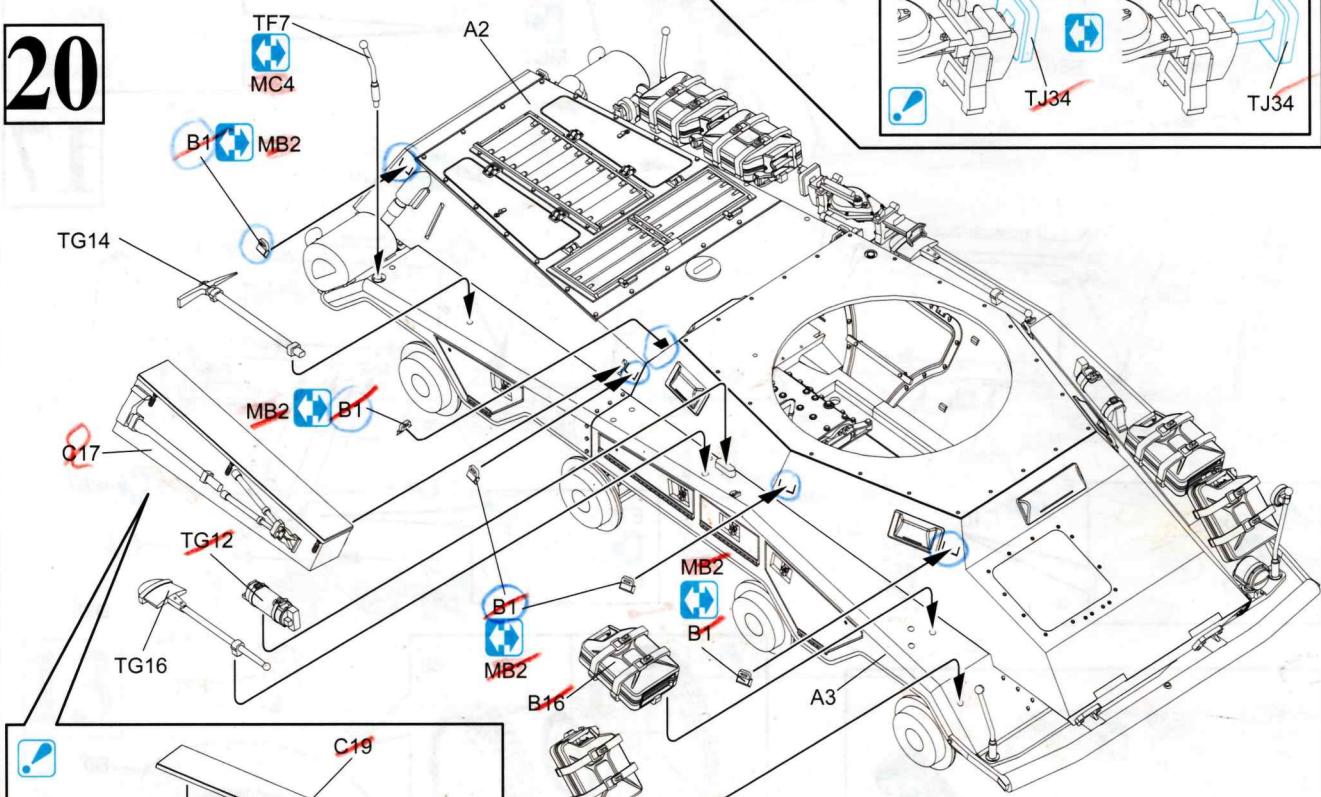

# 21

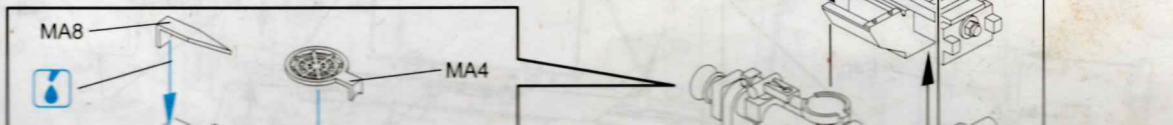



20

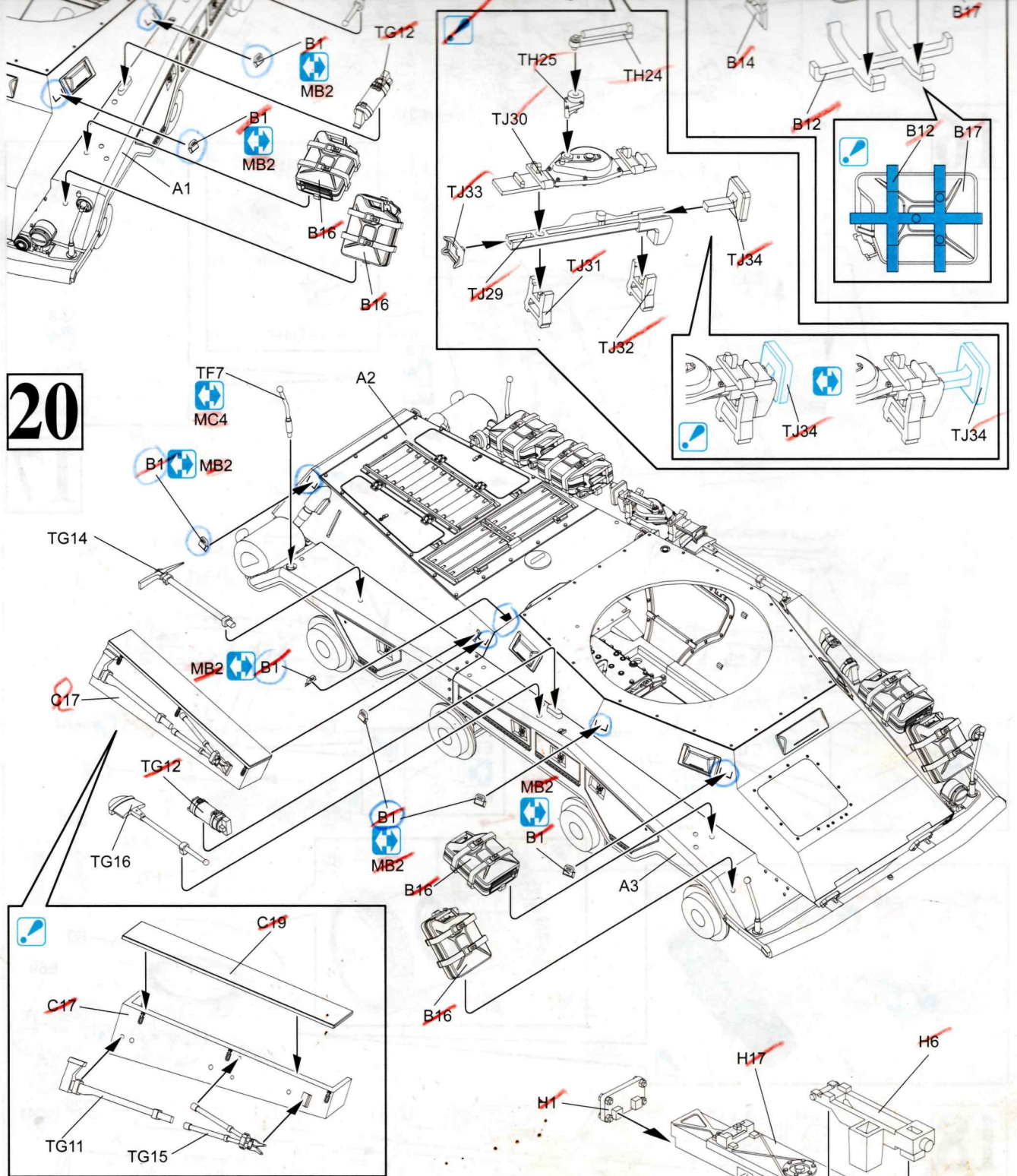

21

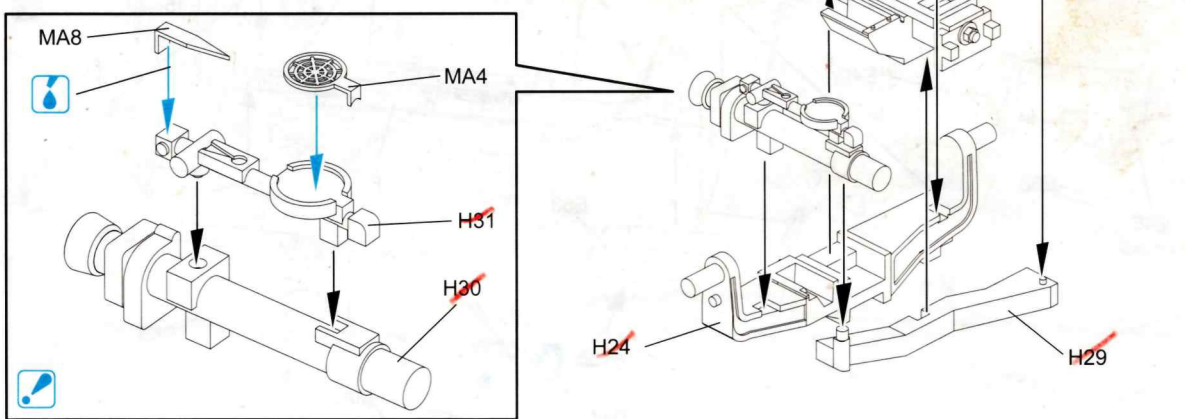



22

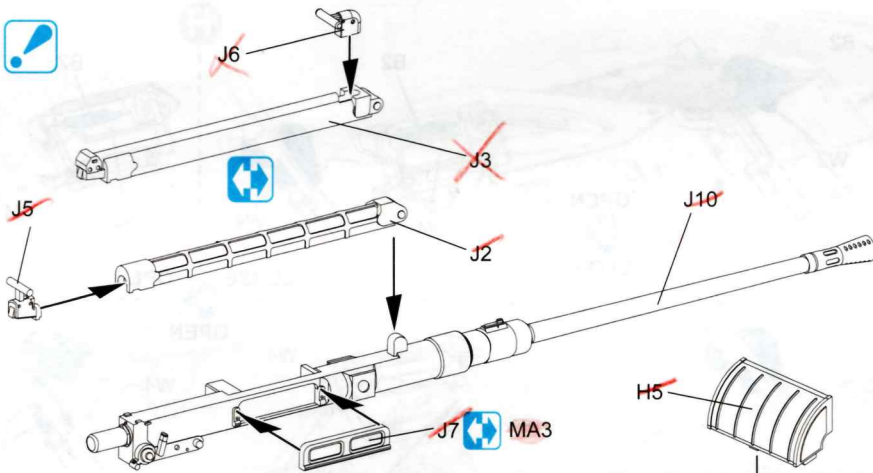

23

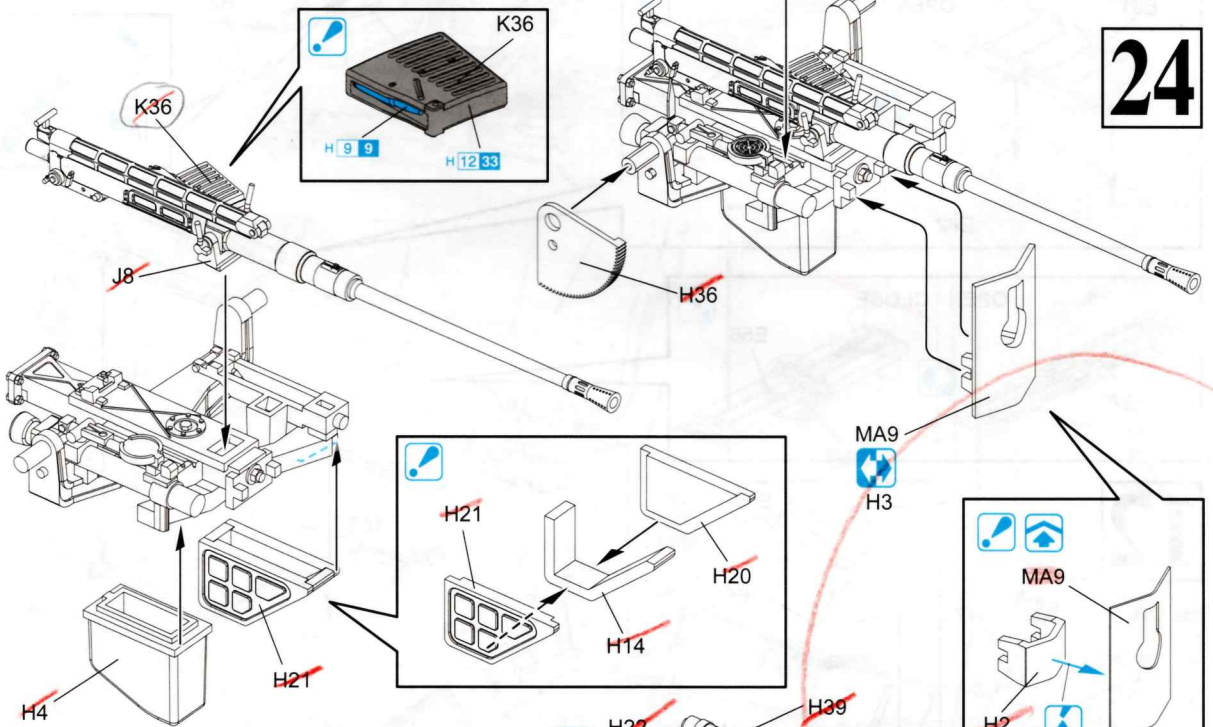

24

25

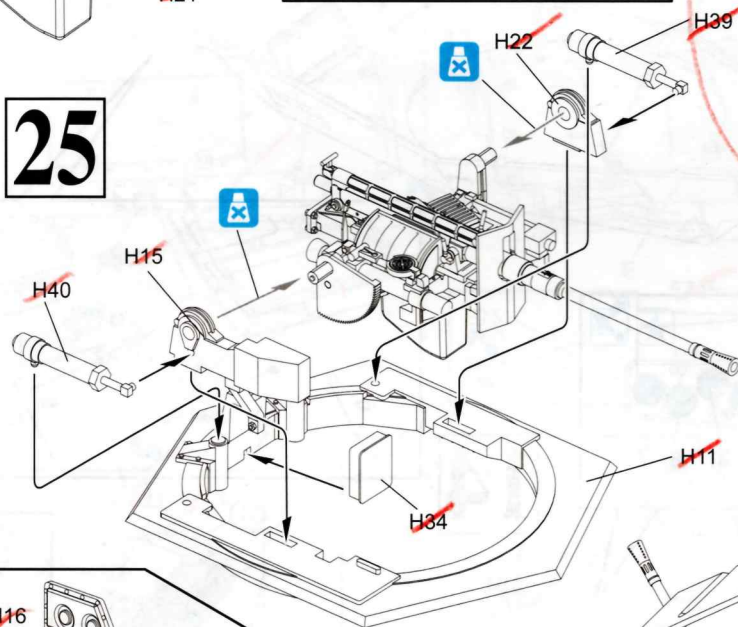

26

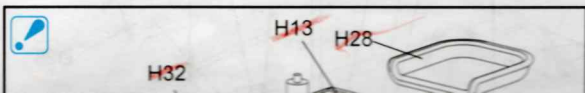
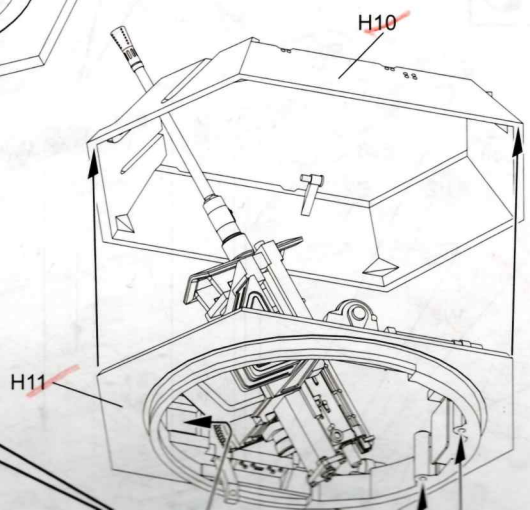
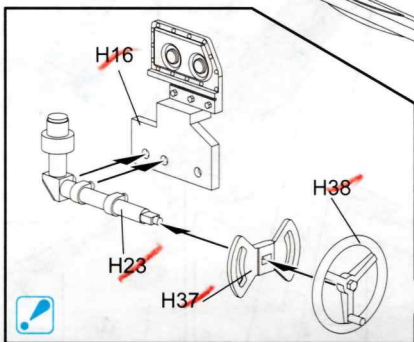



23

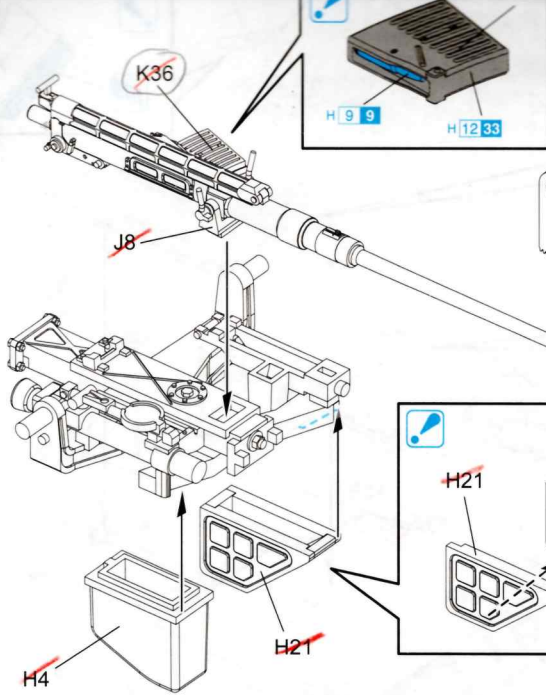

24

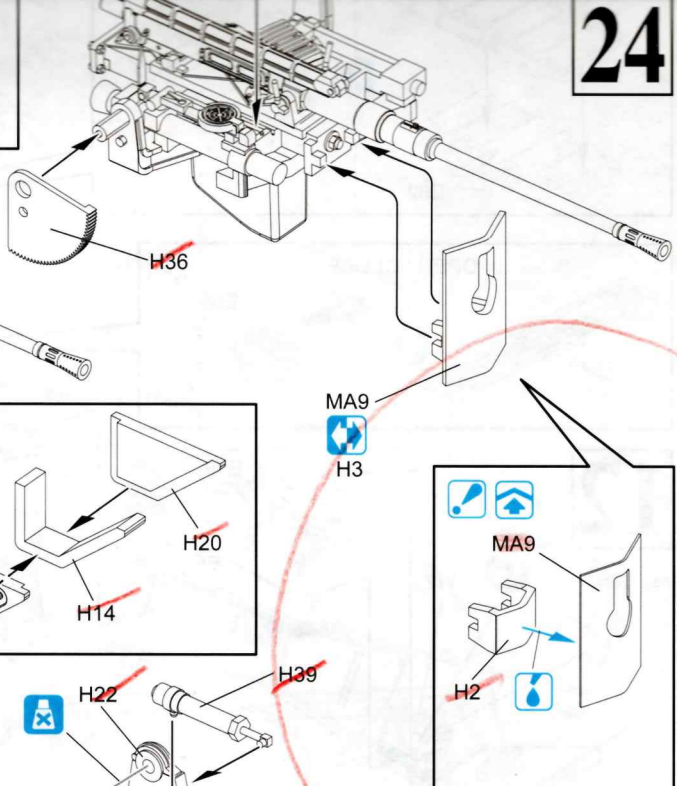

25

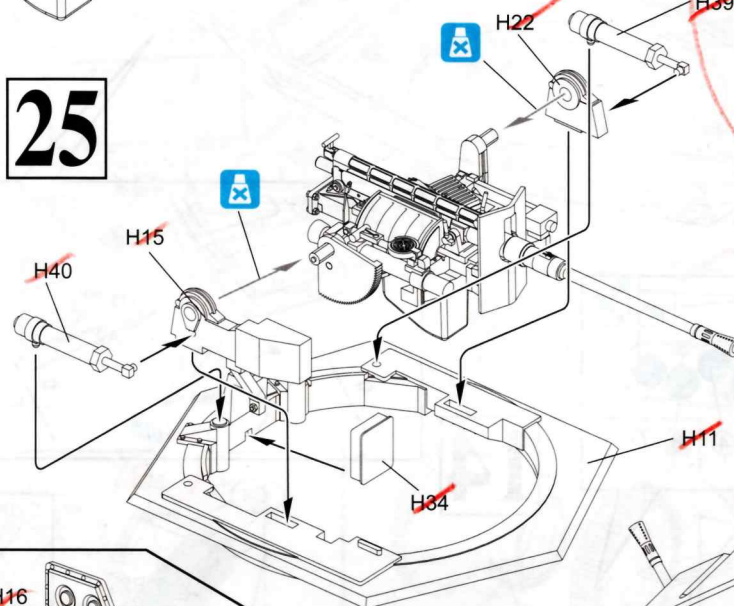

26

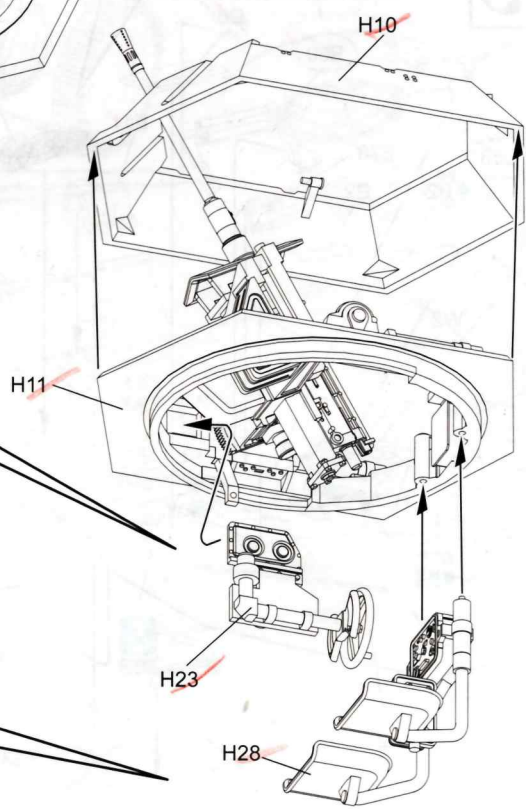
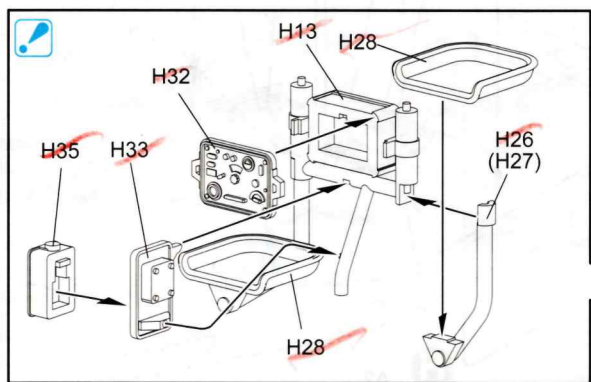
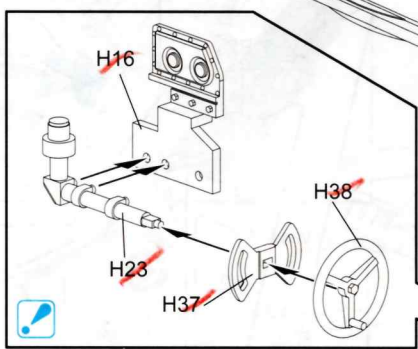



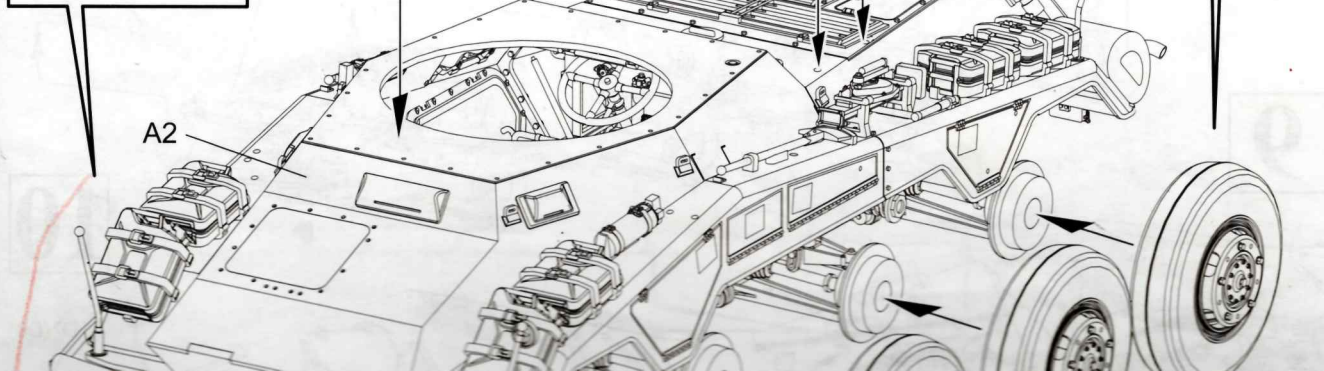
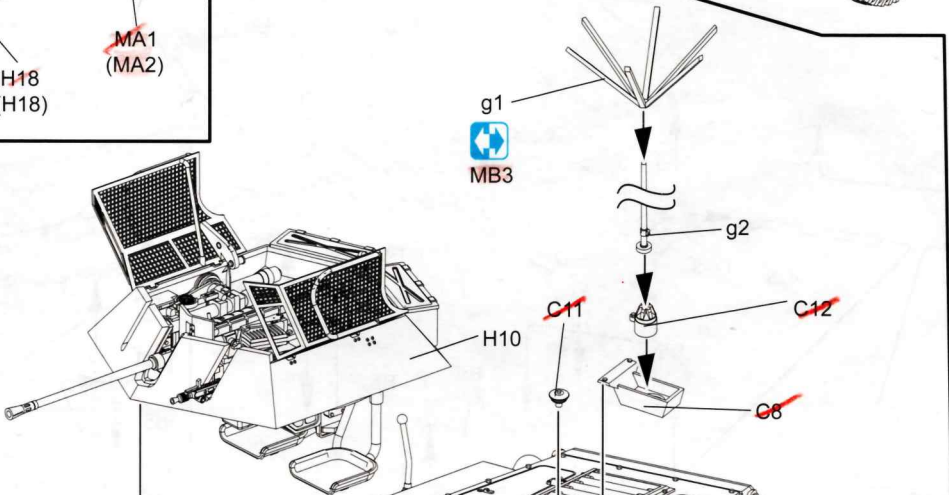
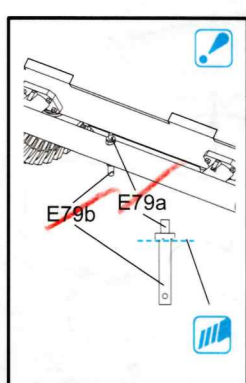
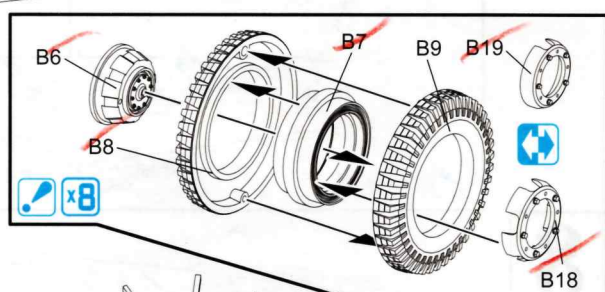
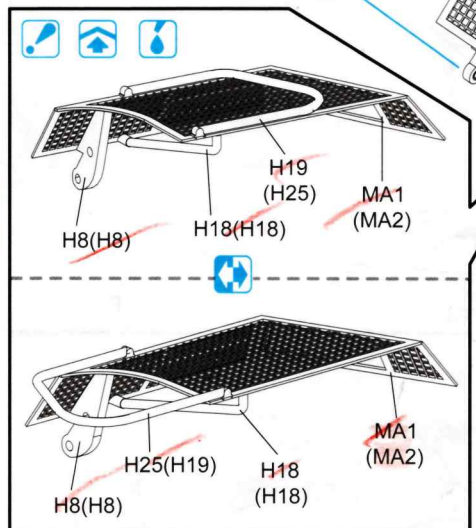
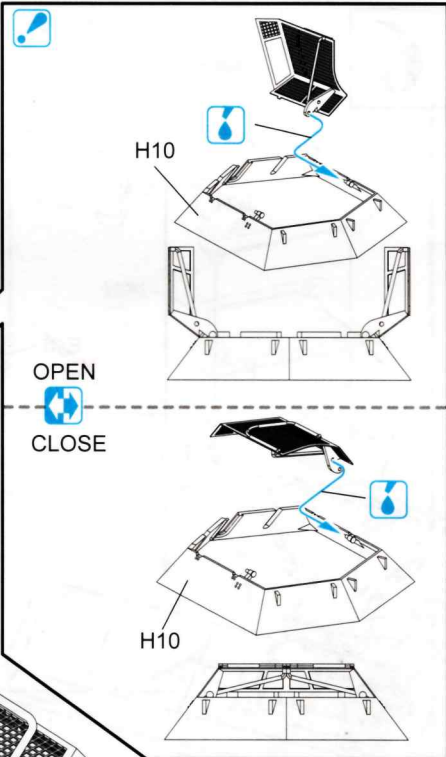
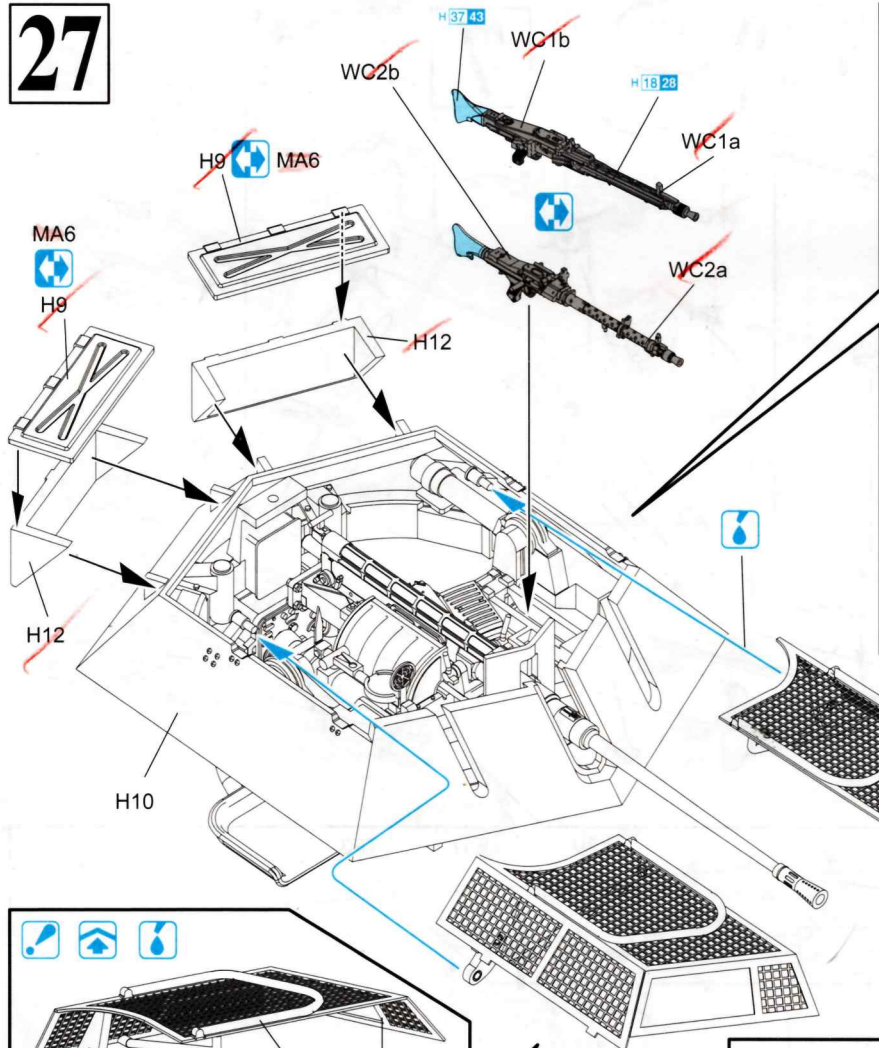



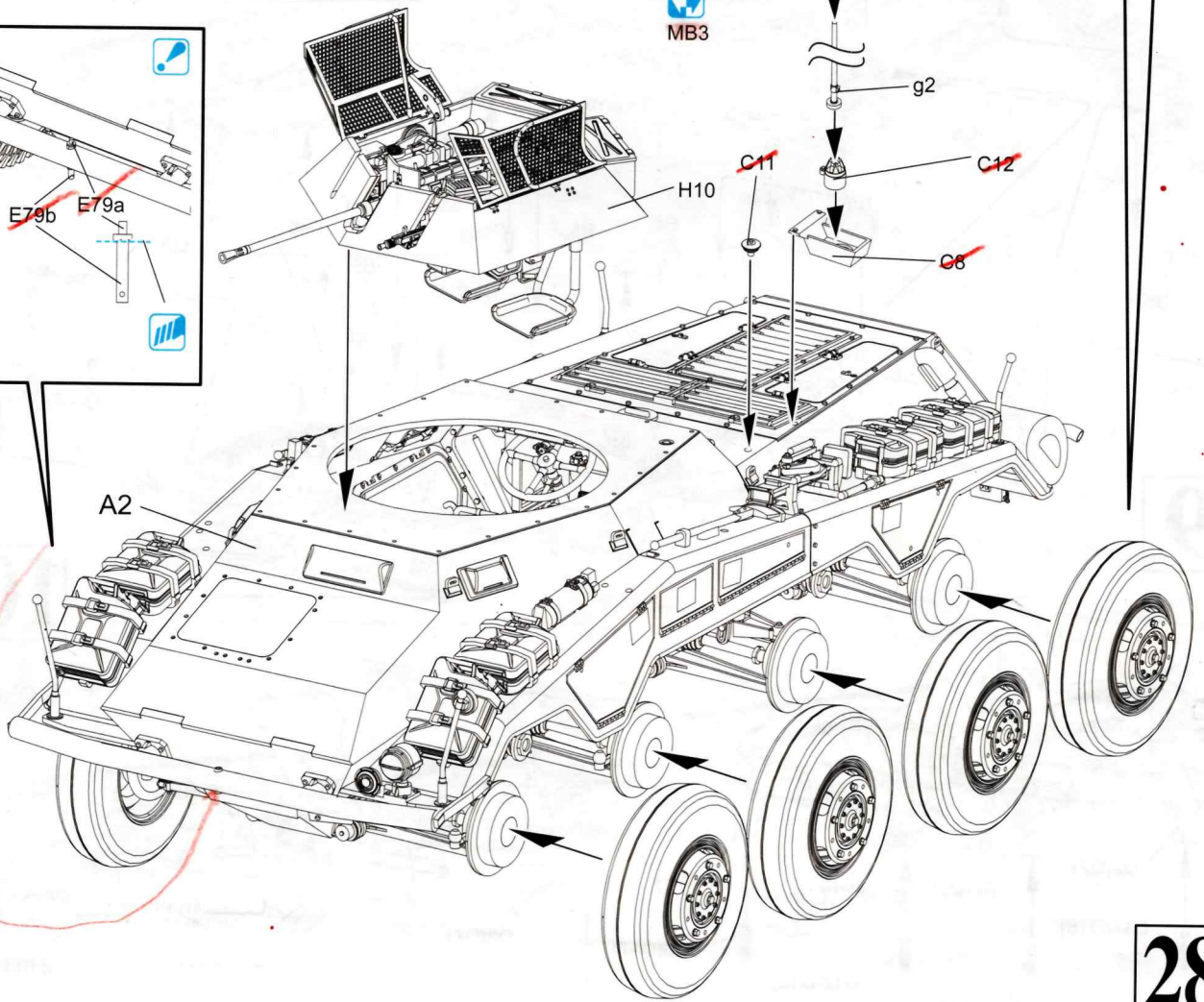
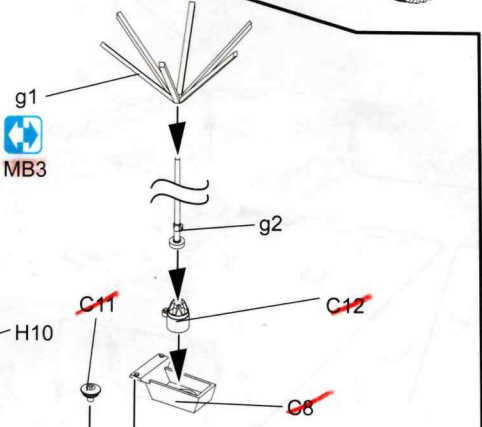
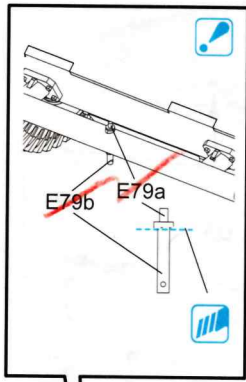
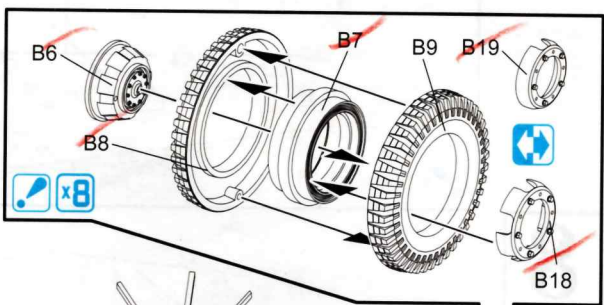
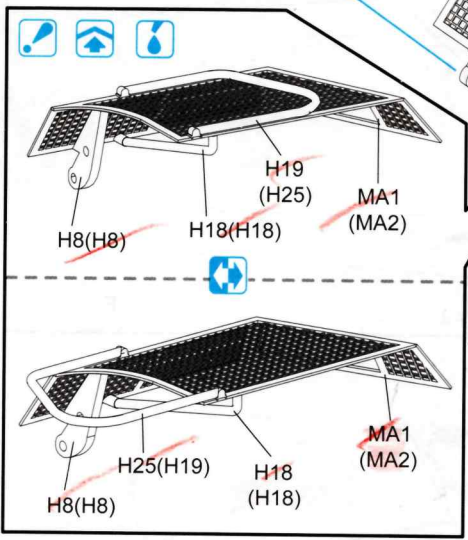
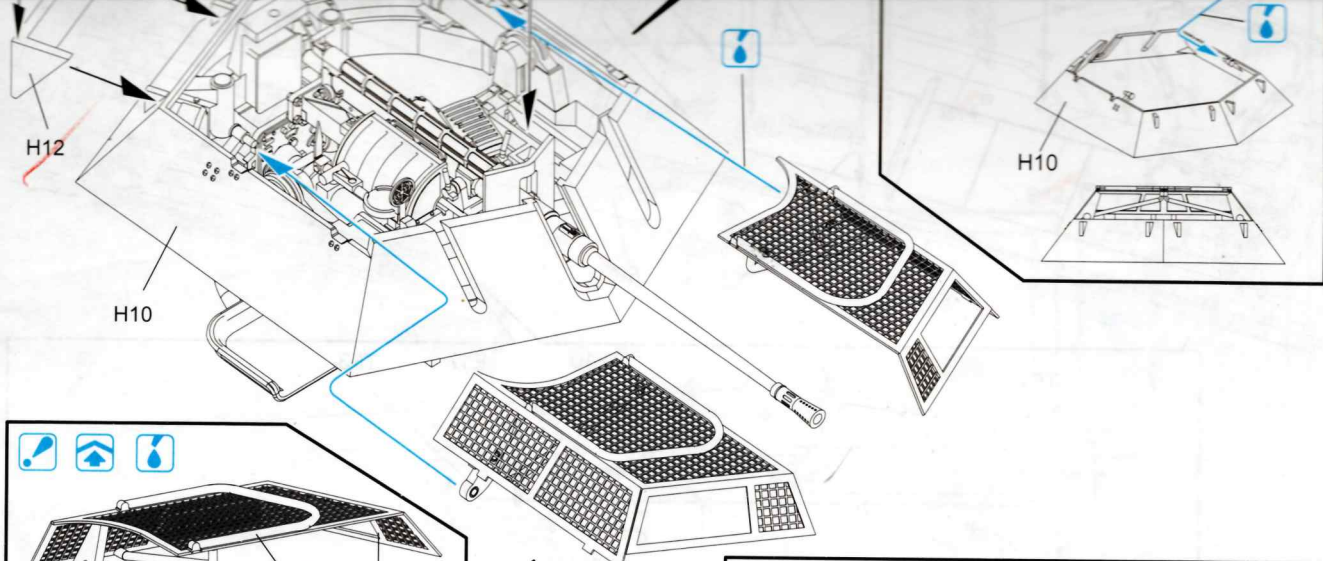



# Painting & Markings

マーキング及び塗装図 Markierungen und Bemalung 標貼及着色指示  
 Decoration et Peinture Marchio & Pittura

## 6.Pz.Div., Austria 1945

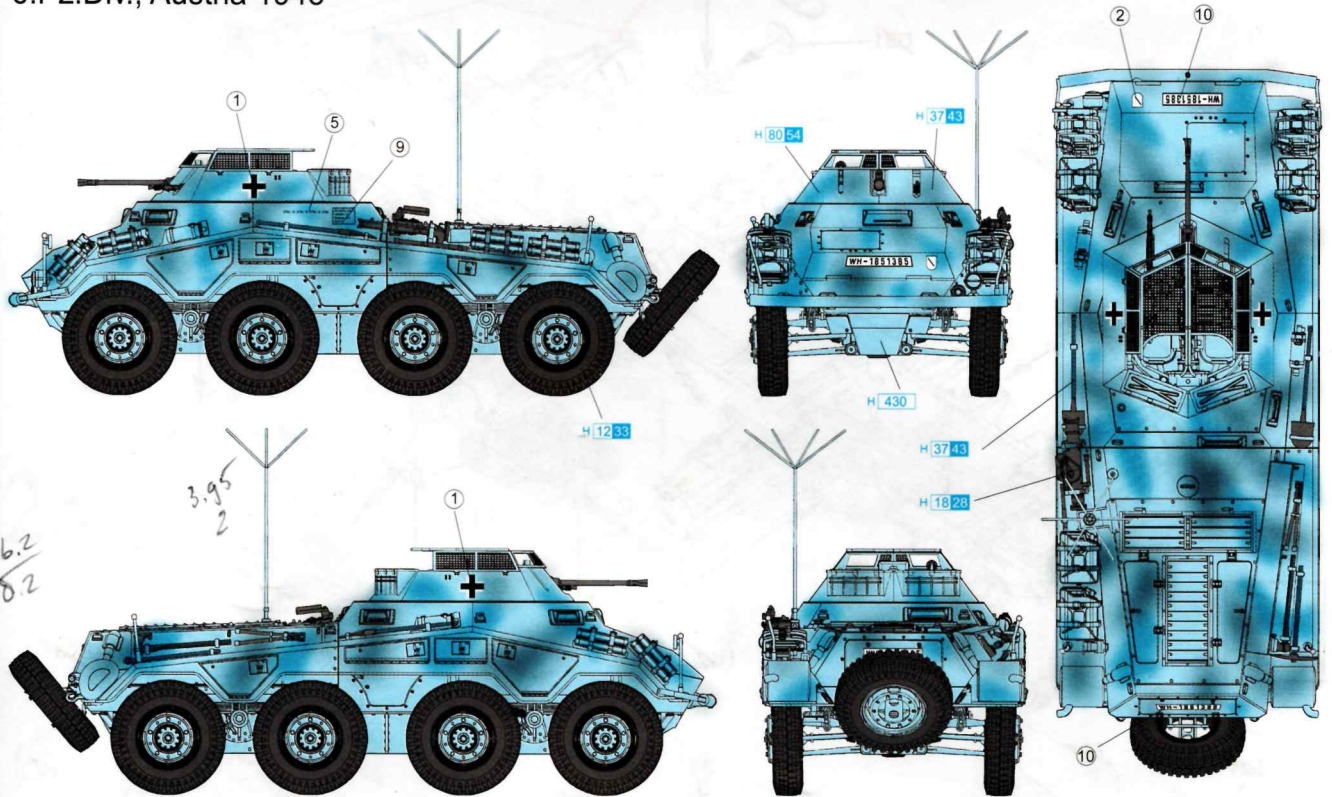

## 25.Pz.Div., Germany 1945

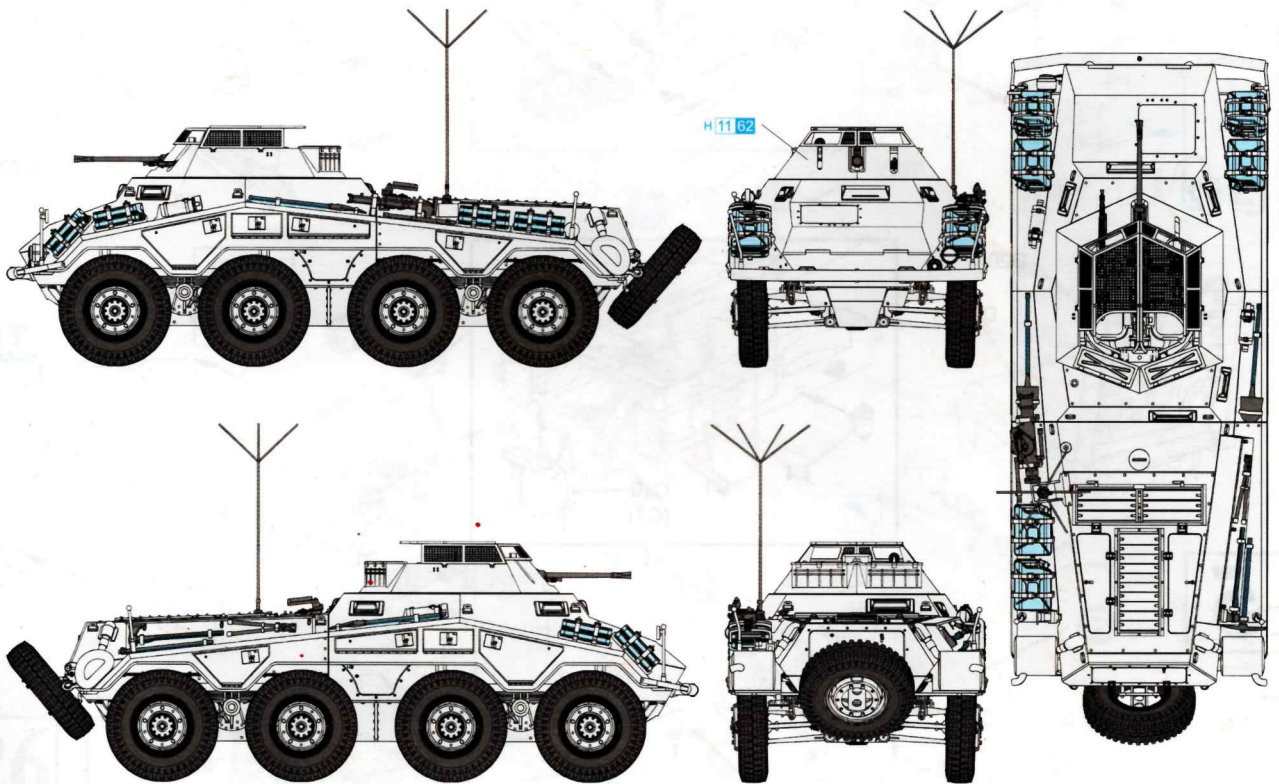

Hull red Tankys F7 + F64

Dragon Europe: c/o Hobby Pro Marketing Ges. m.b.H.  
 Am Leonhardbach 7, A-8010 GRAZ, AUSTRIA



Copyright © 2006  
 6298-01

### ■ デカールの貼り方

- ① デカールを貼るところのほこりや汚れを、ぬらした布できれいにふきとってください。
- ② 貼りたいデカールを台紙ごとハサミで切りとり、1枚ずつ水またはぬるま湯に台紙を下にして20秒くらい浮かべます。
- ③ 水から出したらタオルの上のせ、指先でデカールが動かないか確かめた後、貼るところにおいて静かに台紙をずらします。
- ④ 指先に少し水をつけて正確な位置にデカールを動かした後で、やわらかく、よく水を吸う布でデカールを押さえて内側の水分や気泡を押し出します。
- ⑤ デカールが完全に乾いたら少し水をつけ布で、デカールのまわ

### ■ Correct Method for Applying Decals

- ① Clean the model surface with a wet cloth.
- ② Cut out each decal design from the decal sheet, and dip it in warm water for 20 seconds.
- ③ Use a fingertip to check if the decal is loose from the backing paper. If so, place it in the proper position on the model, and slide it off the backing paper onto the model.
- ④ Move the design to the exact position with a wet fingertip, and squeeze out any excess water or air bubbles under the decal with a soft cotton cloth.
- ⑤ When the decals are dry, use a wet cloth to gently wipe

### ■ Das Korrekte Aufbringen der Abziehbilder

- ① Oberfläche des Modells mit feuchtem Tuch reinigen.
- ② Jedes Motiv einzeln aus dem Bogen herausschneiden und 20 Sekunden in warmes Wasser tauchen.
- ③ Mit dem Finger prüfen, ob sich das Motiv vom Trägerpapier gelöst hat. Wenn ja, so schieben Sie es vom Papier weg und seine genaue Position auf dem Modell.
- ④ Korrigieren Sie die exakte Lage mit nasser Fingerspitze und drücken Sie Wasserblasen unter dem Abziehbild mit einem weichen Baumwolltuch weg.
- ⑤ Entfernen Sie beim Antrocknen der Abziehbilder die



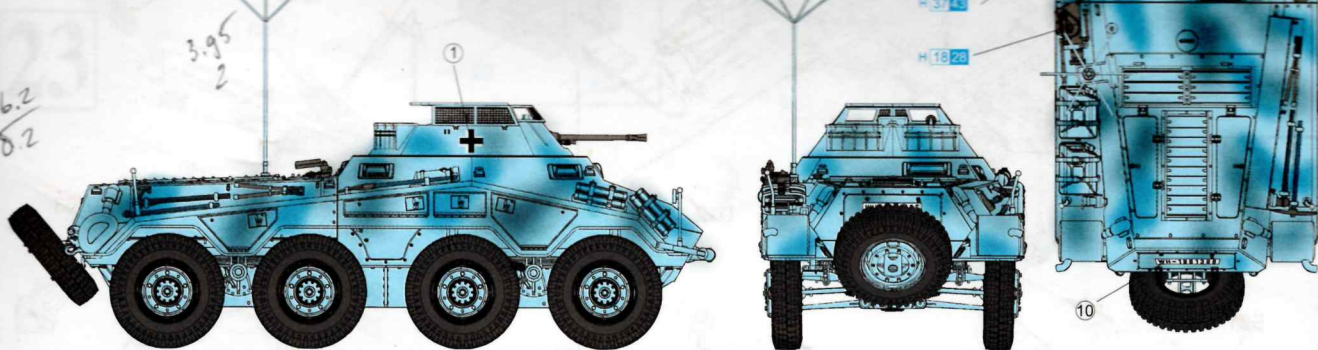

25.Pz.Div., Germany 1945

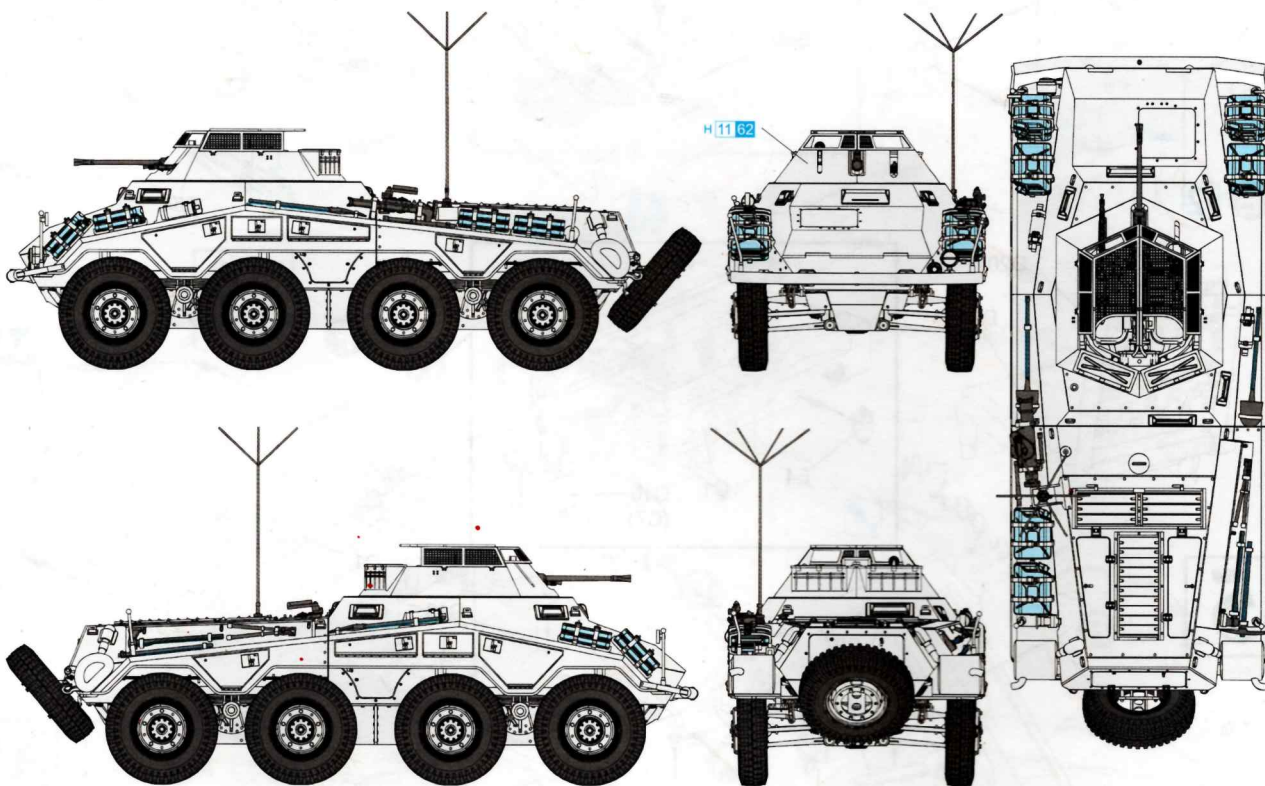

Hull red Tamya F7 + F64

Dragon Europe: c/o Hobby Pro Marketing Ges. m.b.H.  
Am Leonhardbach 7, A-8010 GRAZ, AUSTRIA

**DRAGON** Copyright © 2006  
6298-01

■ デカールの貼り方

- ① デカールを貼るところのほこりや汚れを、ぬらした布できれいにふきとってください。
- ② 貼りたいデカールを台紙ごとハサミで切りとり、1枚づつ水またはぬるま湯に台紙を下にして20秒くらい浮かべます。
- ③ 水から出したらタオルの上のせ、指先でデカールが動くか確かめた後、貼るところにおいて静かに台紙をずします。
- ④ 指先に少し水をつけて正確な位置にデカールを動かした後で、やわらかく、よく水を吸う布でデカールを押さえて内側の水分や気泡を押し出します。
- ⑤ デカールが完全に乾いたら少し水をつけた布で、デカールのまわりのノリをふきとります。

■ Correct Method for Applying Decals

- ① Clean the model surface with a wet cloth.
- ② Cut out each decal design from the decal sheet, and dip it in warm water for 20 seconds.
- ③ Use a fingertip to check if the decal is loose from the backing paper. If so, place it in the proper position on the model, and slide it off the backing paper onto the model.
- ④ Move the design to the exact position with a wet fingertip, and squeeze out any excess water or air bubbles under the decal with a soft cotton cloth.
- ⑤ When the decals are dry, use a wet cloth to gently wipe away any residue left around them.

■ Das Korrekte Aufbringen der Abziehbilder

- ① Oberfläche des Modells mit feuchtem Tuch reinigen.
- ② Jedes Motiv einzeln aus dem Bogen herauserschneiden und 20 Sekunden in warmes Wasser tauchen.
- ③ Mit dem Finger prüfen, ob sich das Motiv vom Trägerpapier gelöst hat. Wenn ja, so schieben Sie es vom Papier weg and seine genaue Position auf dem Modell.
- ④ Korrigieren Sie die exakte Lage mit nasser Fingerspitze und drücken Sie Wasserblasen unter dem Abziehbild mit einem weichen Baumwolltuch weg.
- ⑤ Entfernen Sie beim Antrocknen der Abziehbilder die Klebmittelränder mit einem feuchten Tuch.

■ Modo esatto per applicare le decalcomanie

- ① Pulire la superficie del modello con un panno umido.
- ② Ritagliare ciascun disegno dal foglio decalcomanie e immergerli in acqua calda per 20 secondi.
- ③ Controllare col polpastrello se il disegno è allentato sulla base di carta. In questo caso, applicarlo nella esatta posizione sul modello facendolo scivolare dalla base di carta.
- ④ Spostare il disegno nella esatta posizione mediante il polpastrello umido, quindi togliere l'acqua in eccesso e le bolle d'aria sotto la decalcomania mediante un panno soffice di cotone.
- ⑤ Quando la decalcomania sono asciutte, togliere con un panno umido l'eccesso di colla intorno alla decalcomania stessa.

■ Comment appliquer les décalcomanies correctement

- ① Nettoyer la surface du modèle avec un chiffon humide.
- ② Découper chaque décalcomanie de sa feuille de papier et la plonger dans l'eau tiède pendant vingt secondes.
- ③ Vérifier avec le bout du doigt si le dessin se détache de son papier-support. Si oui, le positionner à l'endroit choisi sur le modèle et retirer doucement le papier-support.
- ④ Positionner la décalcomanie correctement avec un doigt humide et éponger tout restant d'eau et toutes bulles d'air sous la décalcomanie avec un chiffon doux.
- ⑤ Quand les décalcomanies sont sèche, détacher le colle autour des décalcomanies avec un chiffon humide.

■ 貼上水印標貼的正確方法：

- ① 用濕布抹乾淨模型表面。
- ② 按照各標貼的形狀從標貼紙上切出，浸到溫水之中約 20 秒。
- ③ 用指尖試行觸摸以確定標貼是否已脫離底紙，如果屬實，則把標貼連底紙放到模型表面的適當位置上，小心地將底紙移去，把標貼留在模型表面。
- ④ 以濕水的指尖把標貼移到正確的位置上，再用柔軟的綿質布料把標貼輕壓，以擠出標貼底下的氣泡和水份。
- ⑤ 標貼乾後，用濕布輕拭標貼及其附近的模型表面，以洗去可能殘留在標貼附近的多餘膠水，確保效果完美。