

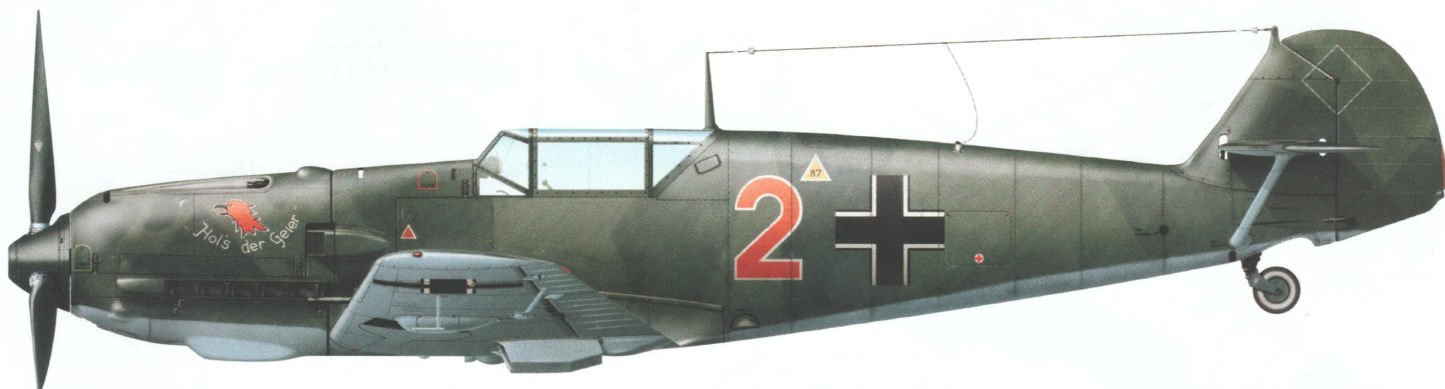

Messerschmitt Bf 109 E-3

32004



OPTION
FACULTATIF
NACH BELIEBEN
HACER AQUERO
DO WYBORU
FACOLTATIVO
VOLBA



CA GLUE
COLLA CA
CA KLEBER
PEGAMENTO CA
KLEJ CA
COLLE CA
CA LEPIDLO



REMOVE
RETRERER
ENTFERNEN
CORTAR
WYCIĄC
SEPARARE
ODSTRANIT

1

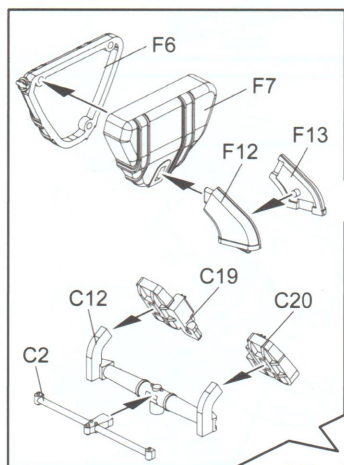
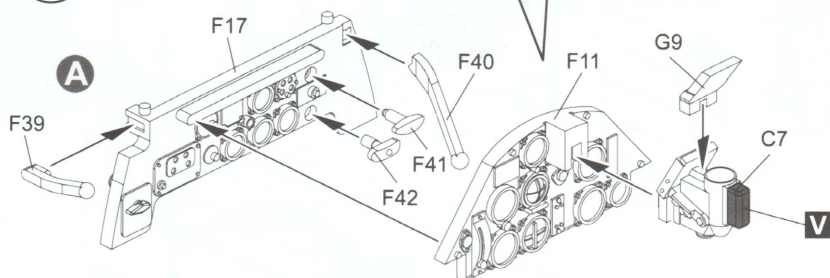
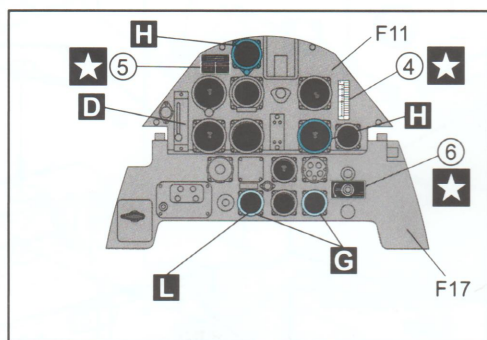

2

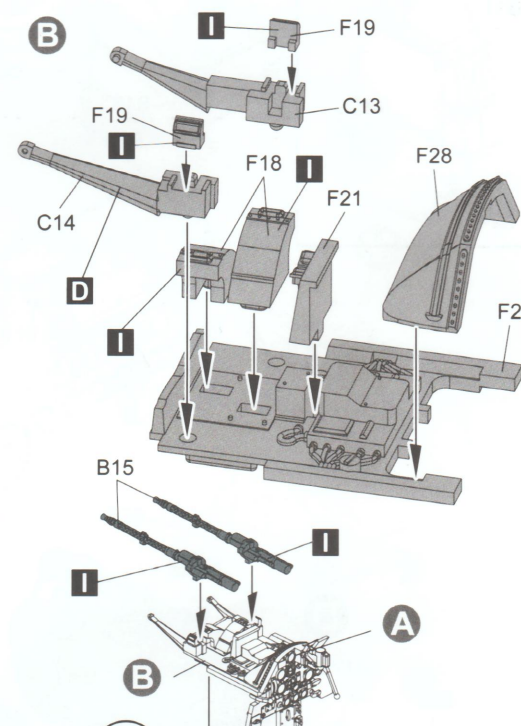
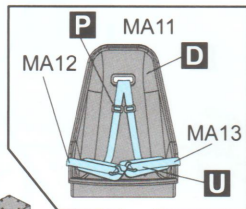

3

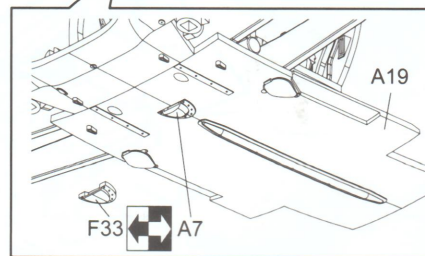

4

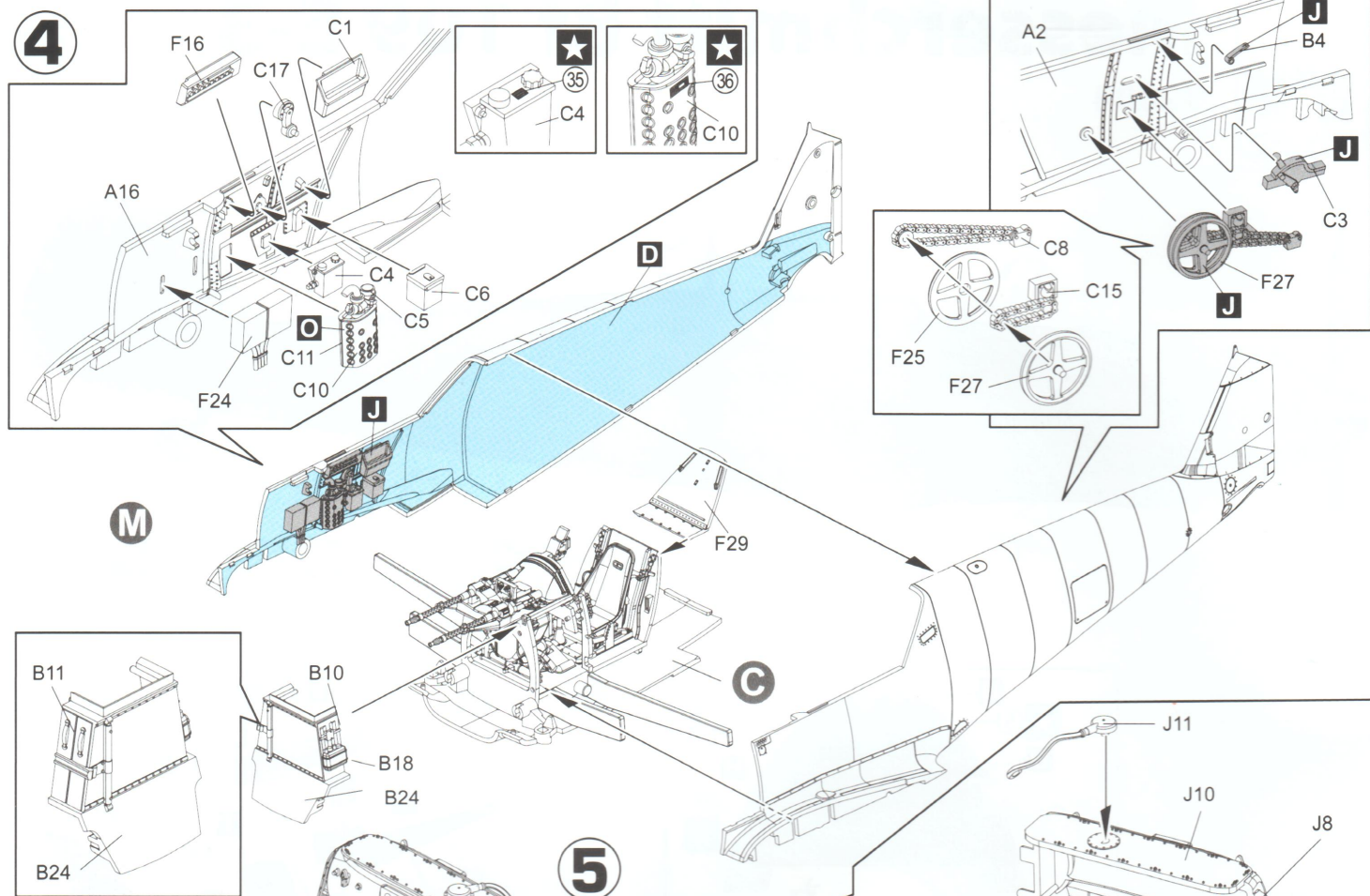

5

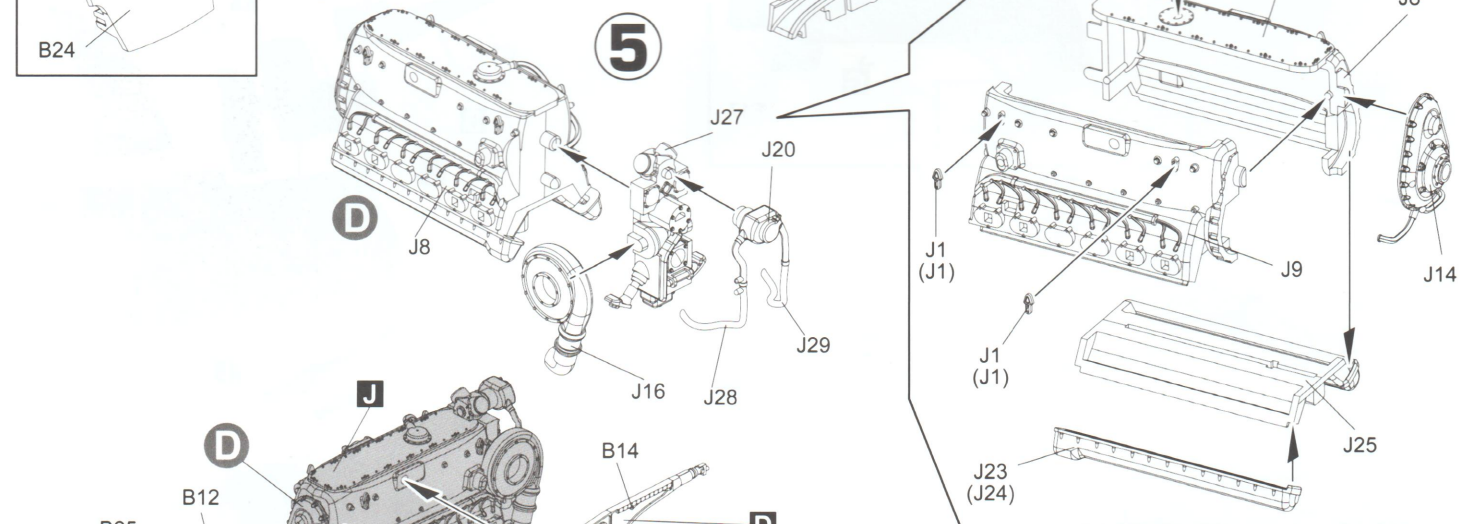

6

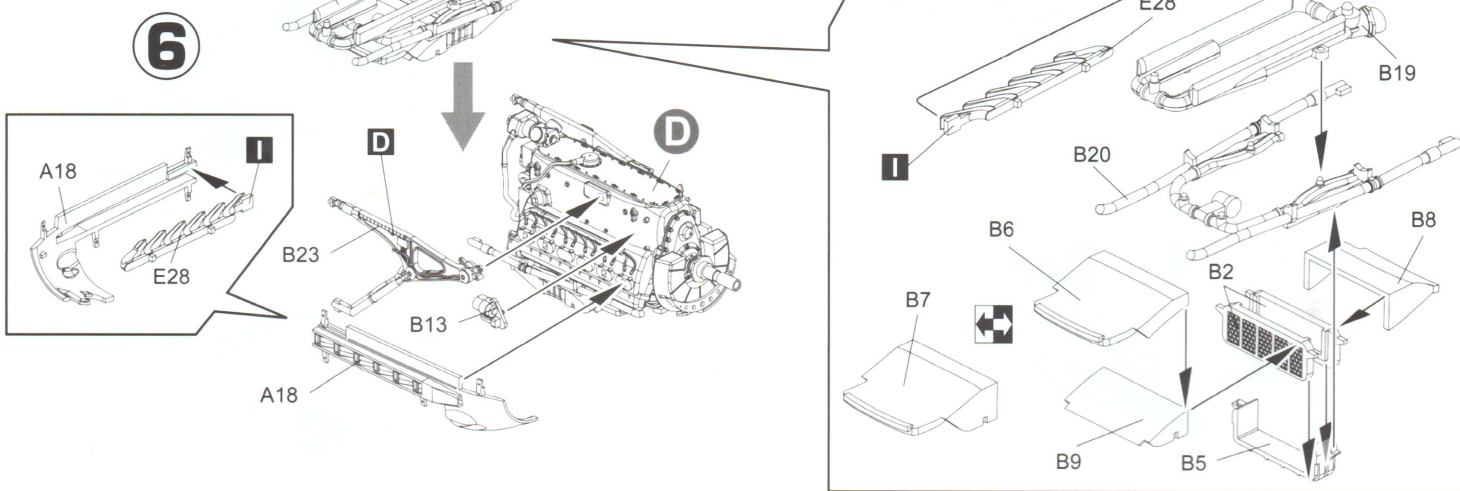

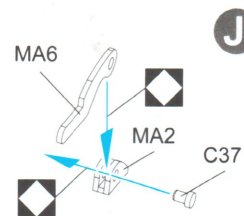
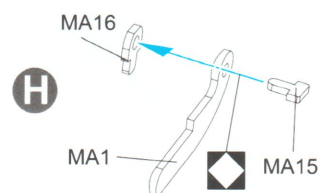
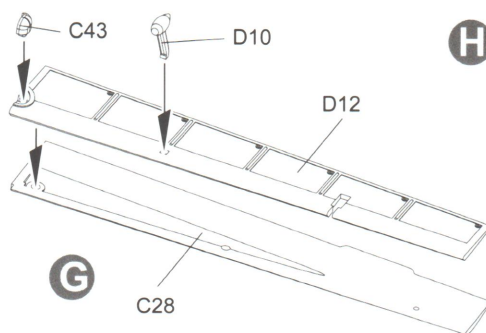
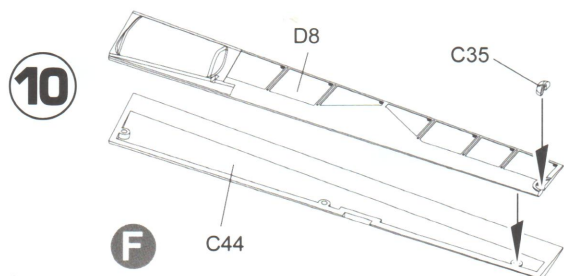
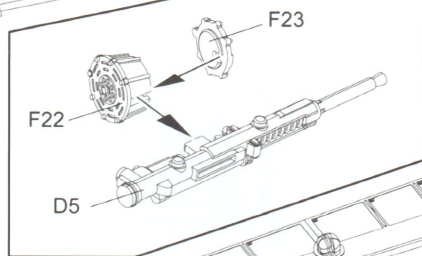
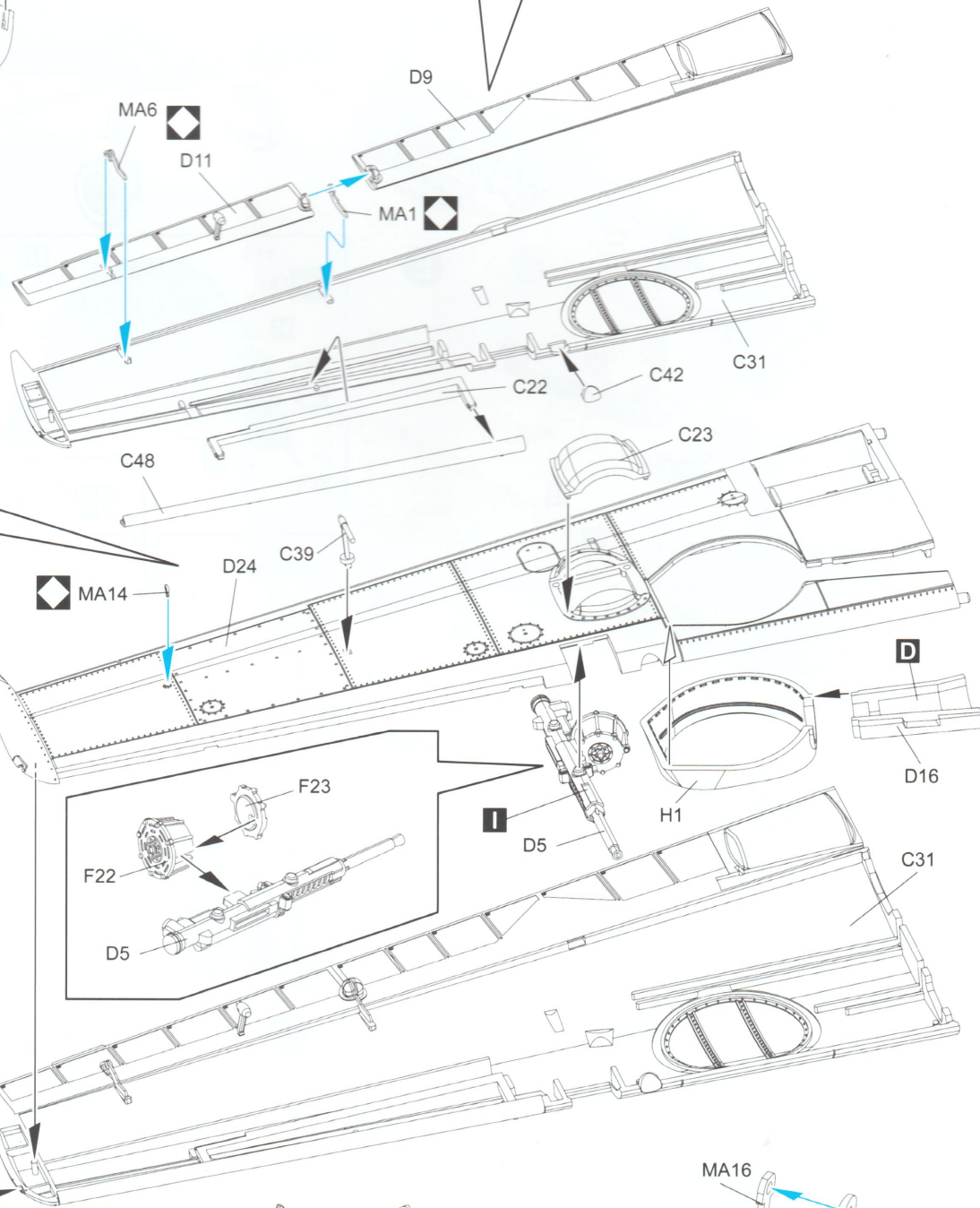
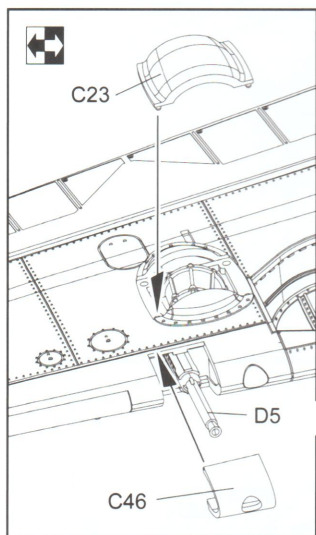
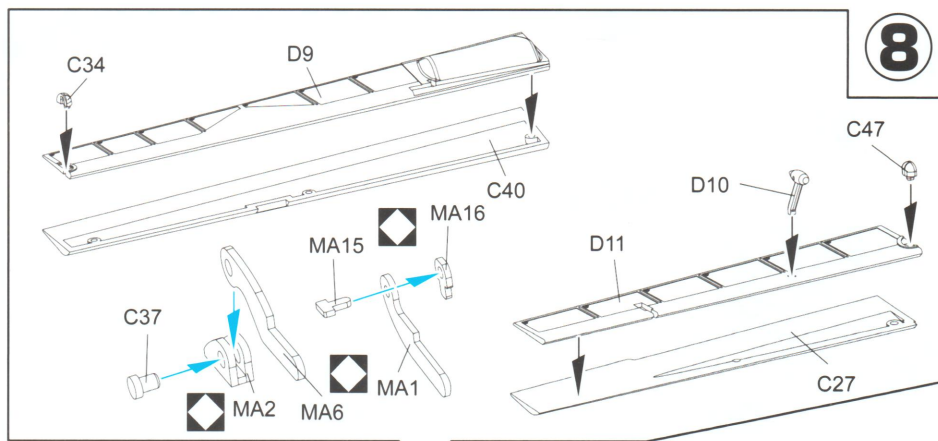
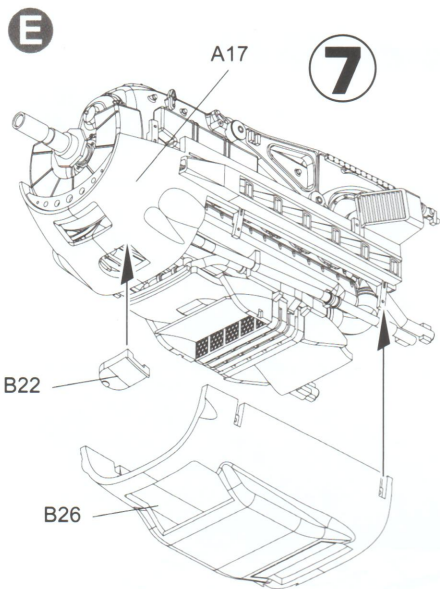

11

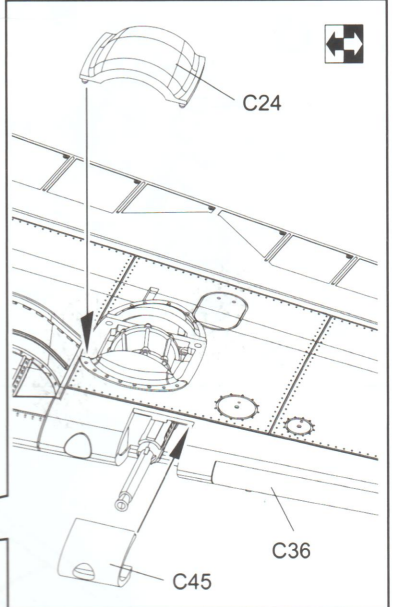
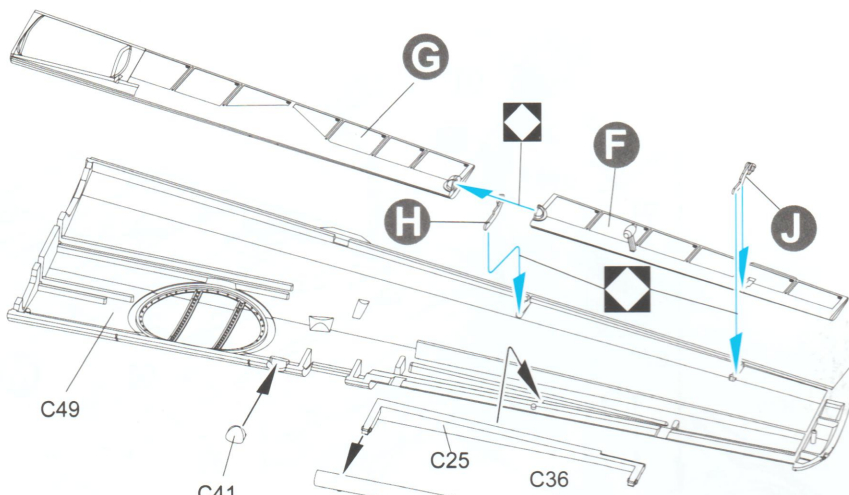

12

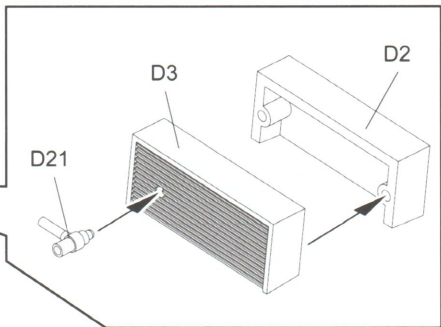
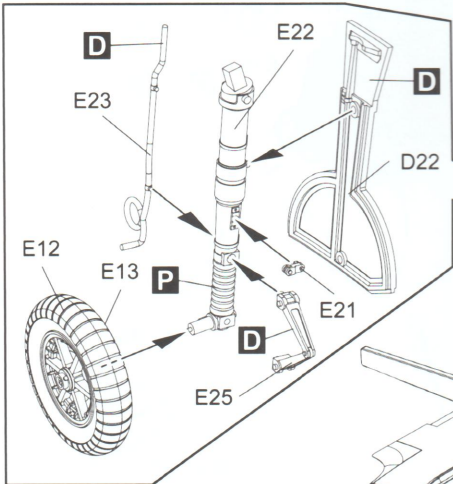
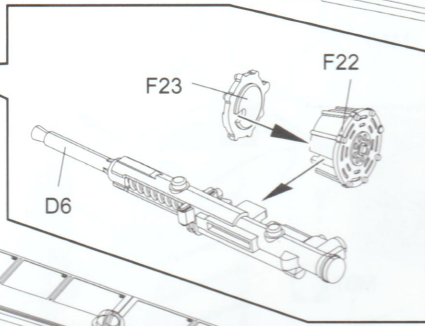
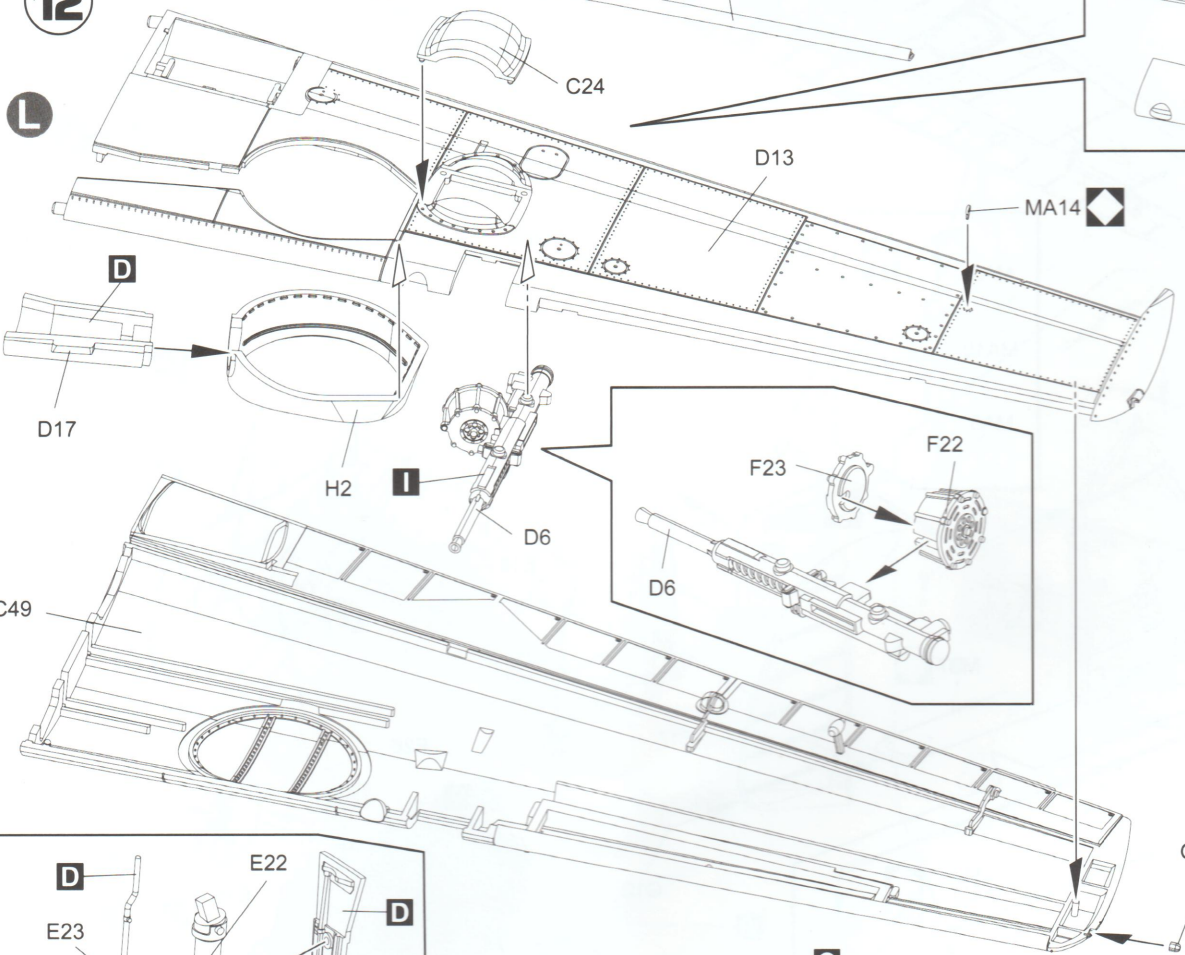

13

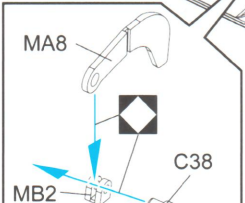
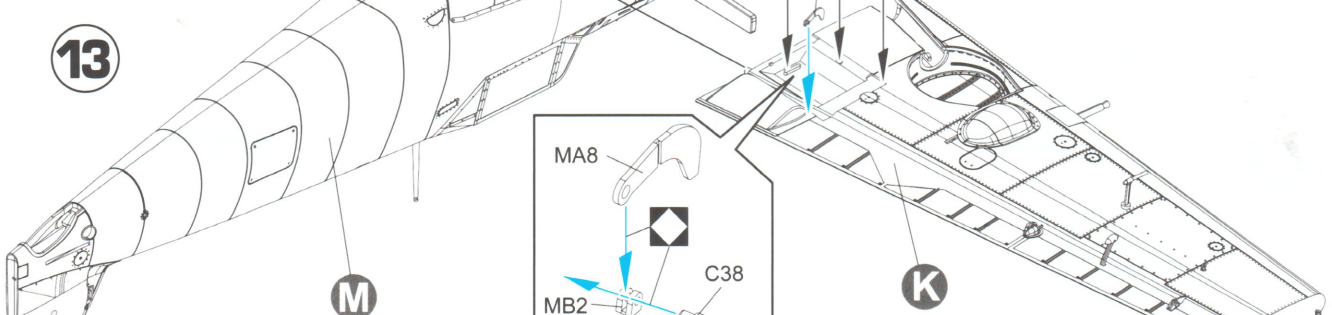

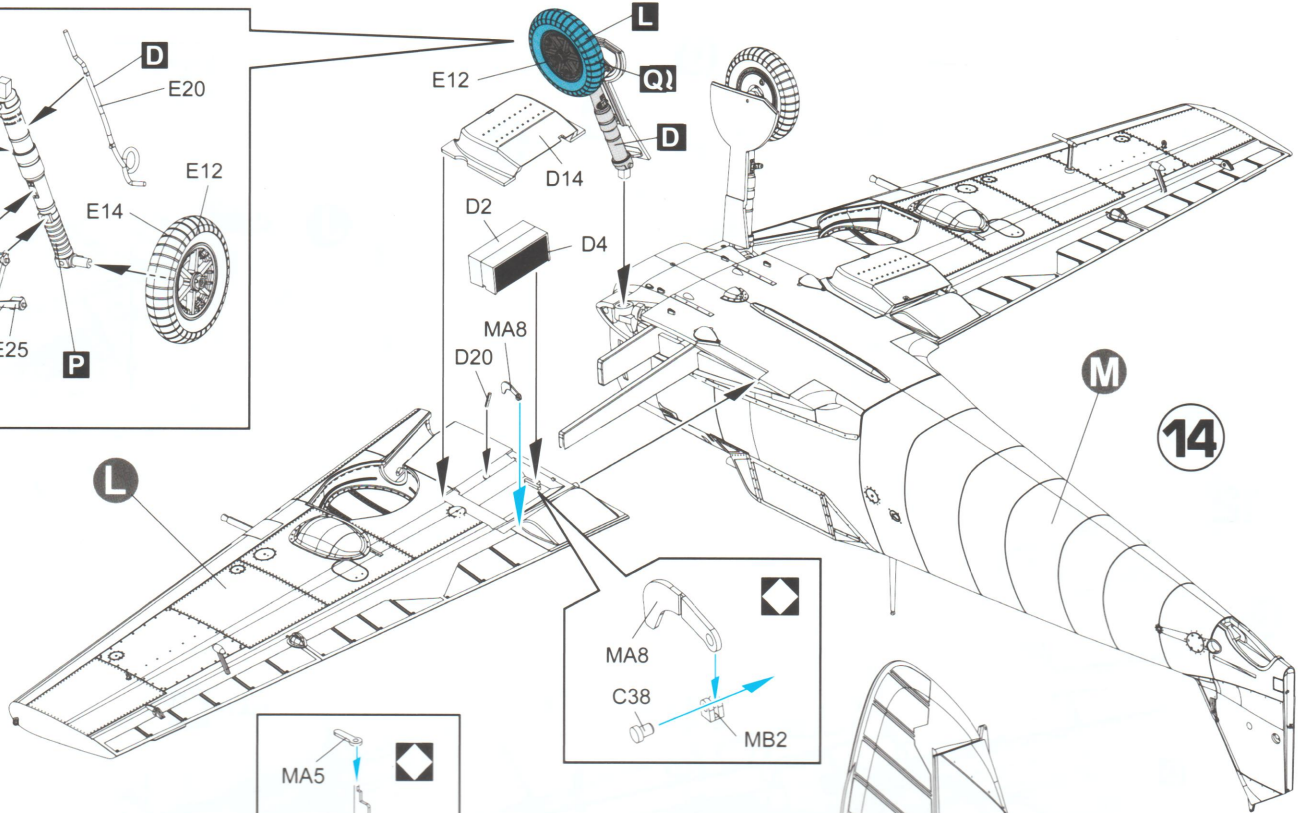
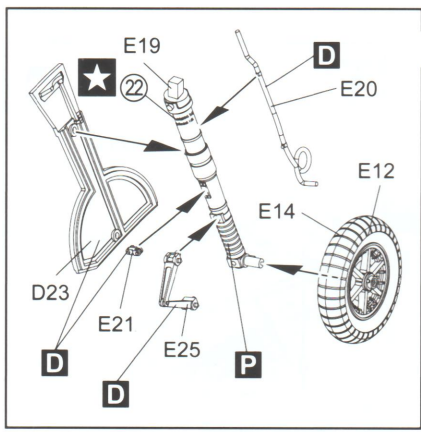

15

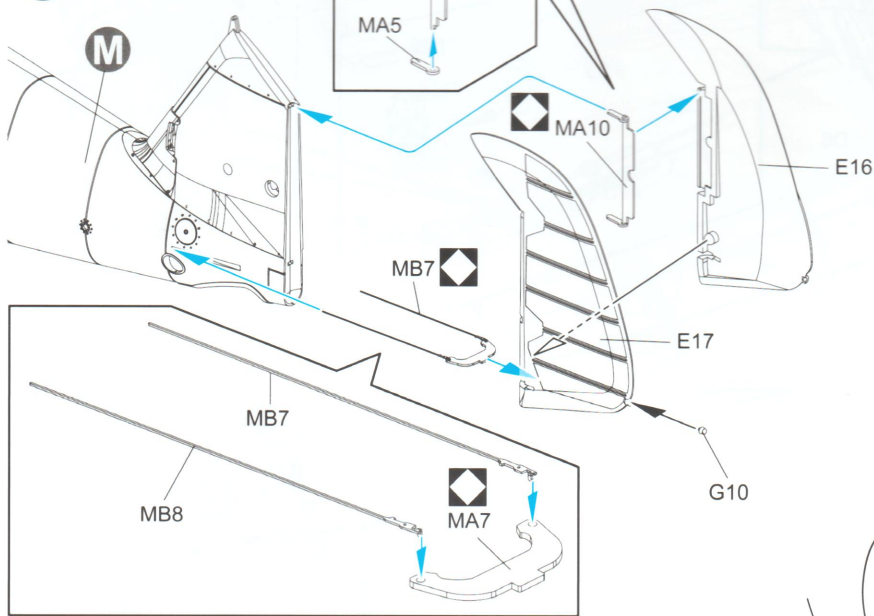

16

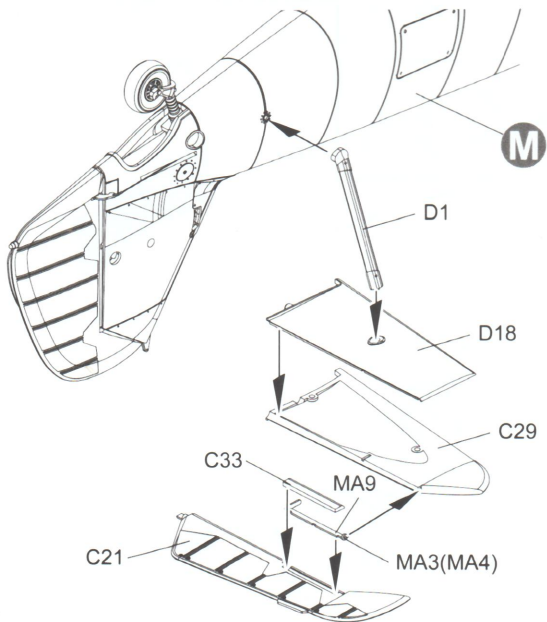
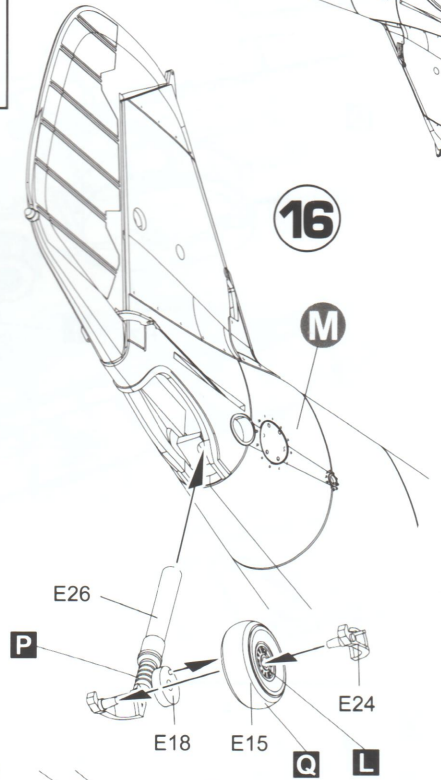

17

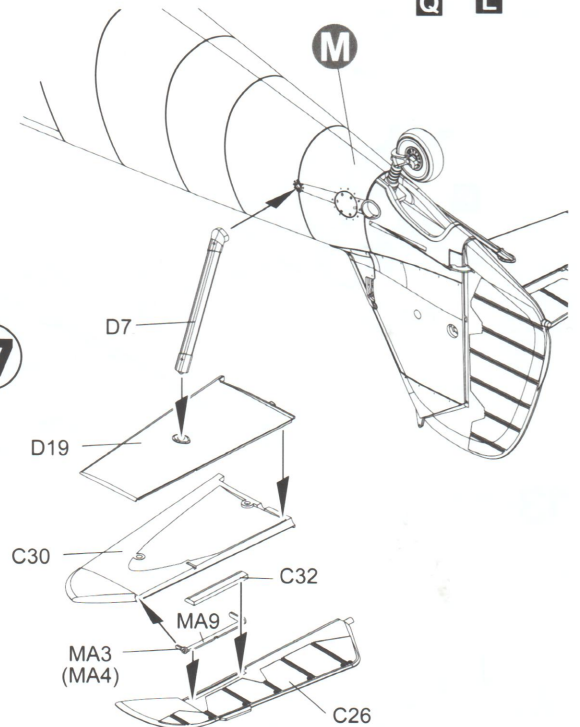

18

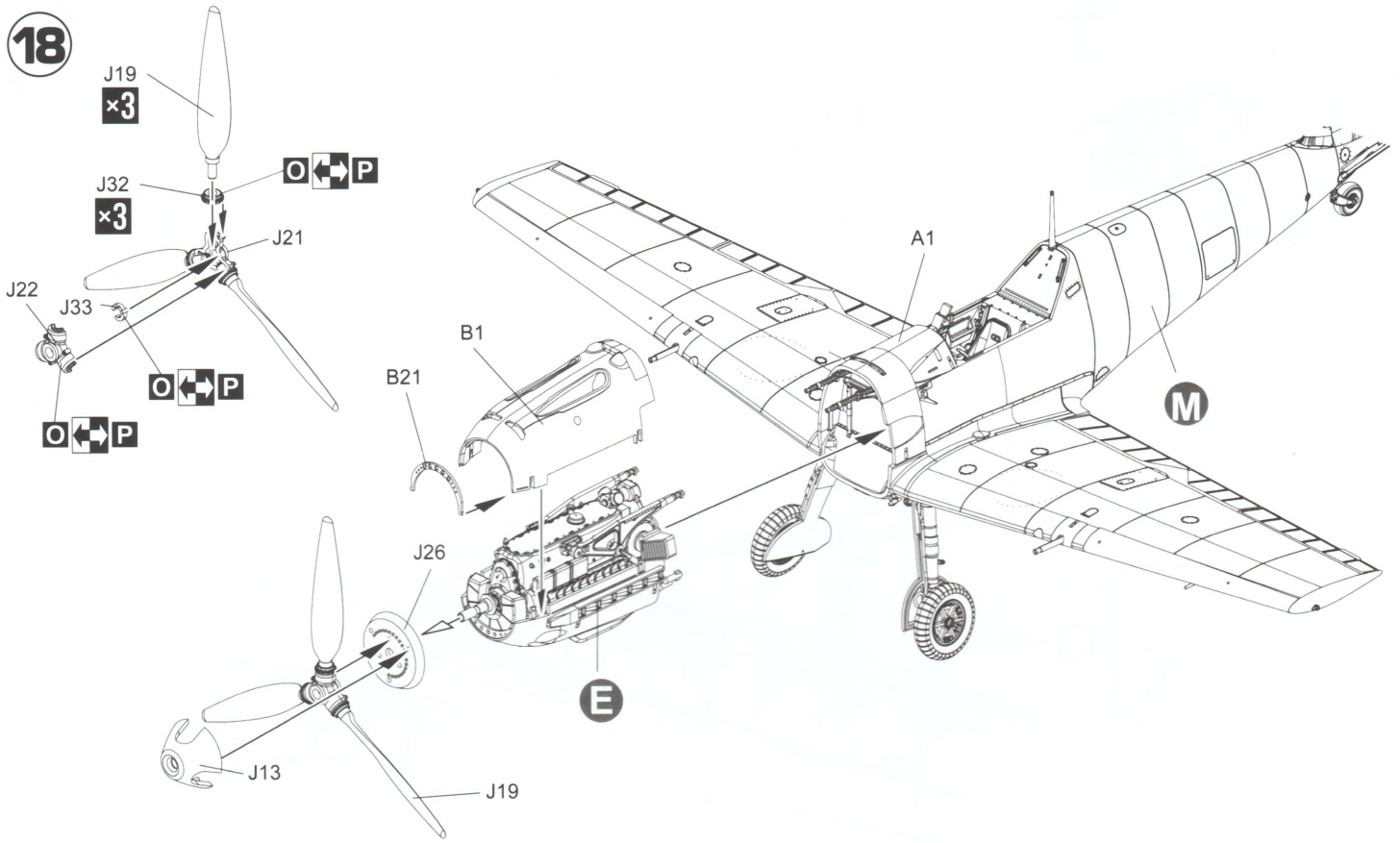

19

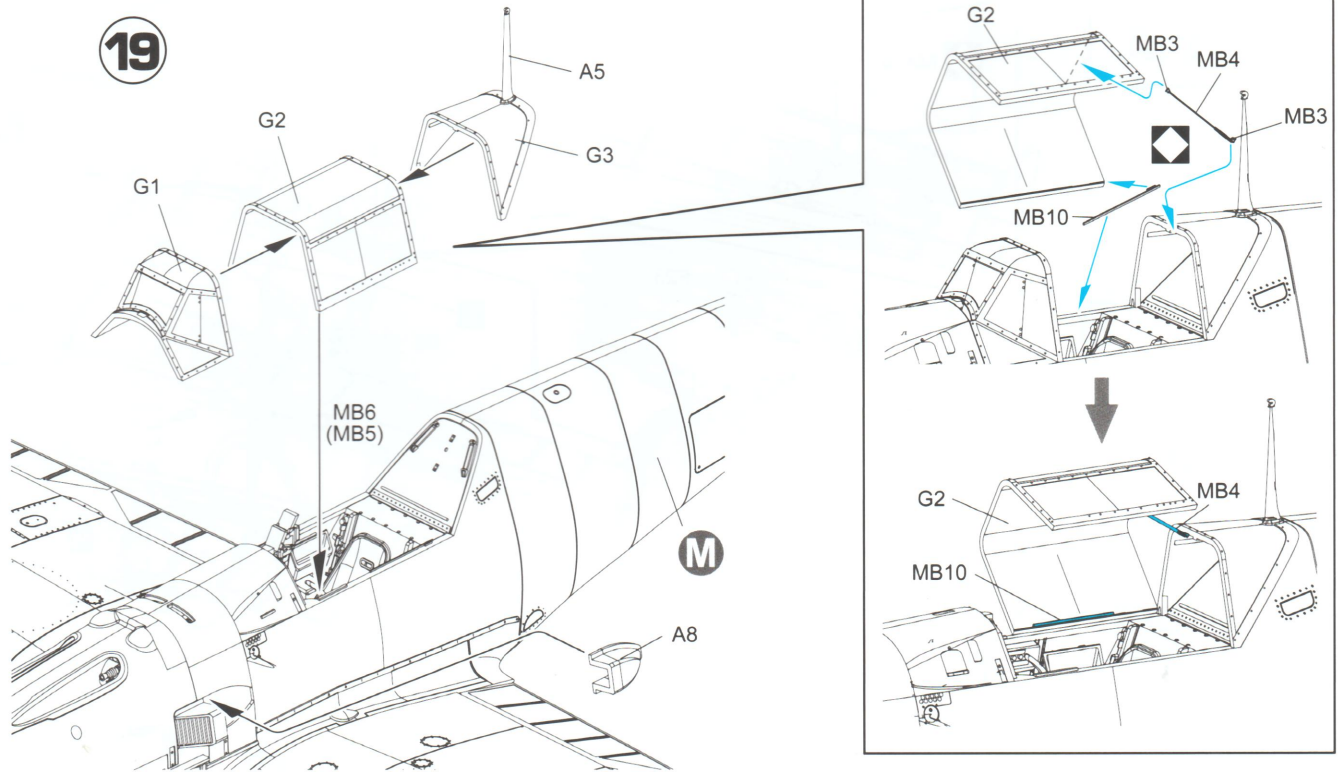

OPEN

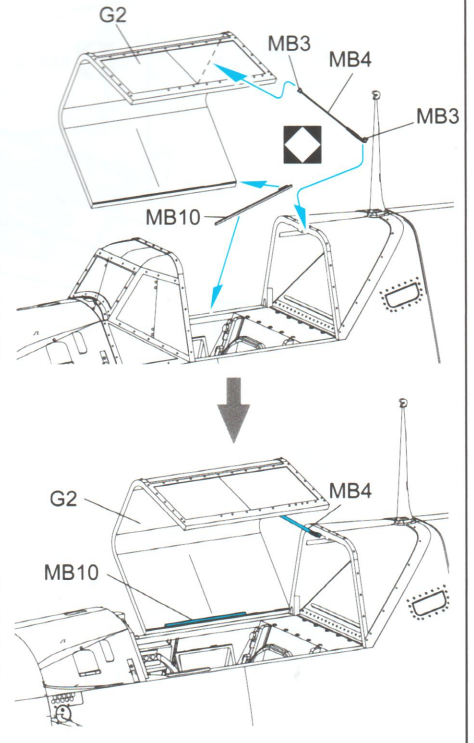



Messerchmitt Bf 109 E-3

32004

PARTS LIST

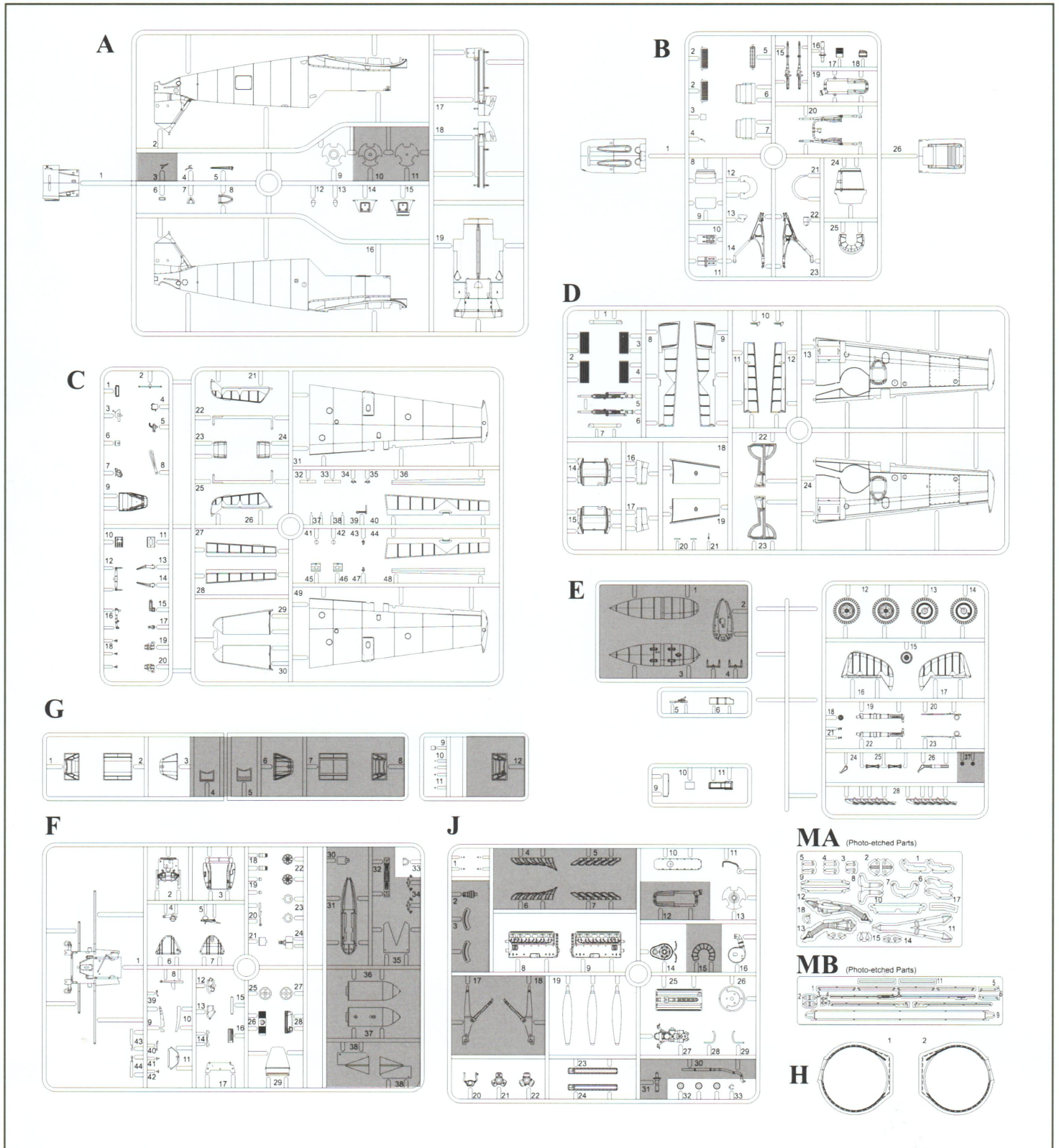

PARTS NOT FOR USE



Messerschmitt Bf 109 E-3

32004

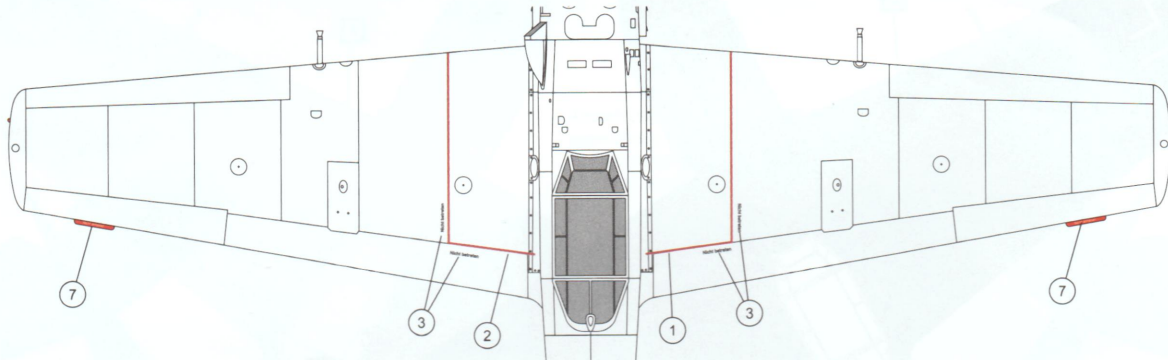
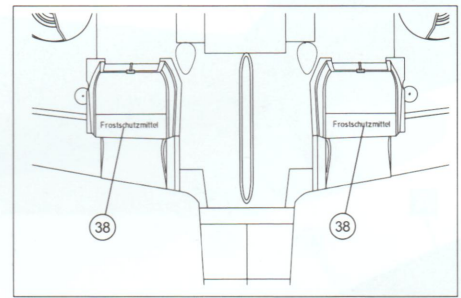
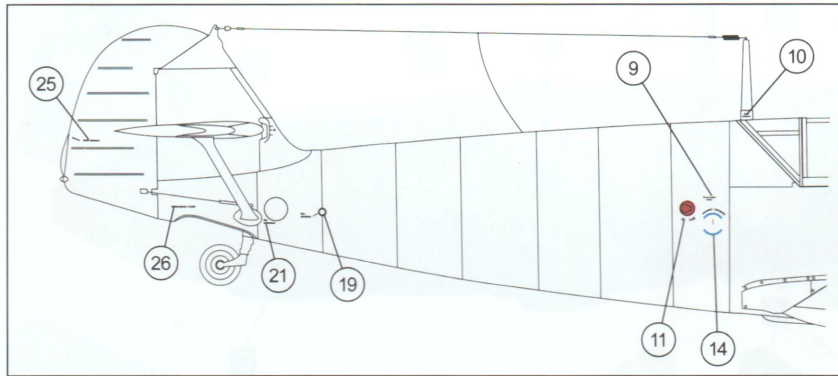
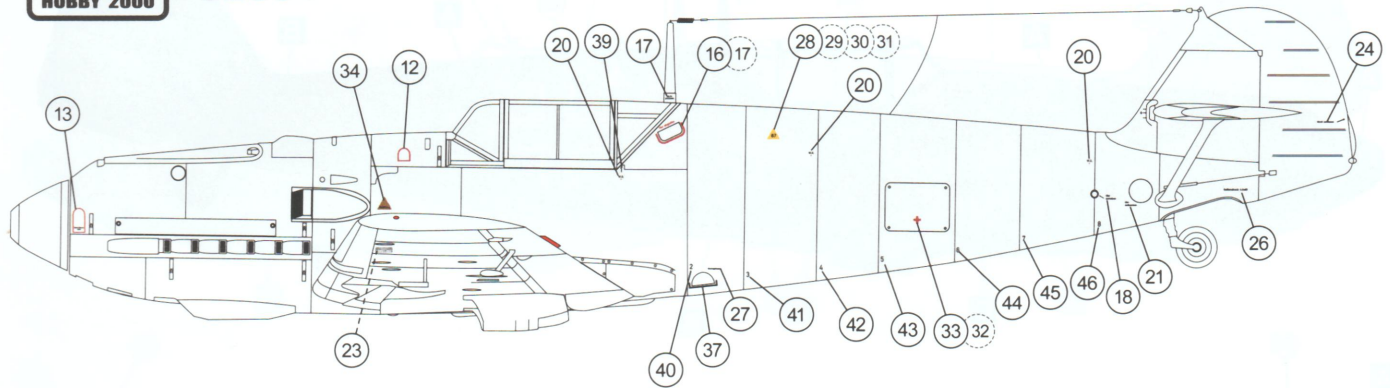

Color Chart		AK Interactive	Alclad2	AMMO	HATAKA	Mr. COLOR	Revell	TAMIYA
RLM 70 Black Green	A	RC274	E216	232	015	C18	140	XF-27
RLM 71 Dark Green	B	RC275	E647	233	017	C17	139	XF-62+XF-49
RLM 65 Light Blue	C	RC271	E214	231	029	C115	149	XF-23+XF-2
RLM 02 Gray	D	RC265	E202	217	023	C60	145	XF-22
RLM 66 Black Gray	E	RC339	E215	218	040	C116	109	XF-24
RLM 04 Flat Yellow	F	RC267	E649	048	066	C113	113	XF-3
Flat Green	G	RC012		054	221	C135	364	XF-5
RLM 23 Flat Red	H	RC005	E651	049	132	C79	330	XF-7
Burnt Metal	I	AK-484	121	187	016	C61		XF-84
Flat Black	J	RC001	E102	046	100	C33	108	XF-1
Flat White	K	RC004	101	050	101	C62	105	XF-2
Gloss Black	L	AK-471	305			C02	107	X-1
Clear Red	M	RC503	401	093		C47	731	X-27
Clear Blue	N	RC504	403	098		C50	752	X-23
Steel	O	AK-476	112	191		C28	191	
Silver	P	RC020	112	195	003	C08	190	X-11
Tyre Black	Q	RC022	E310	033	040	C137	106	XF-85
RLM 78 Light Blue	R	RC280	E231	247	314	C118	149	XF-23
RLM 79 Sand Yellow	S	RC282	E304	222	014	C119	116	XF-59
RLM 80 Olive Green	T	RC284		248	053	C120	363	XF-26
Buff	U	RC013		122	184	45	189	XF-57
Leather Brown	V	AK-11110	E302	133	186	C44	184	XF-10



Bf 109 E-3, 2.(J)/LG 2, Poland,
September 1939

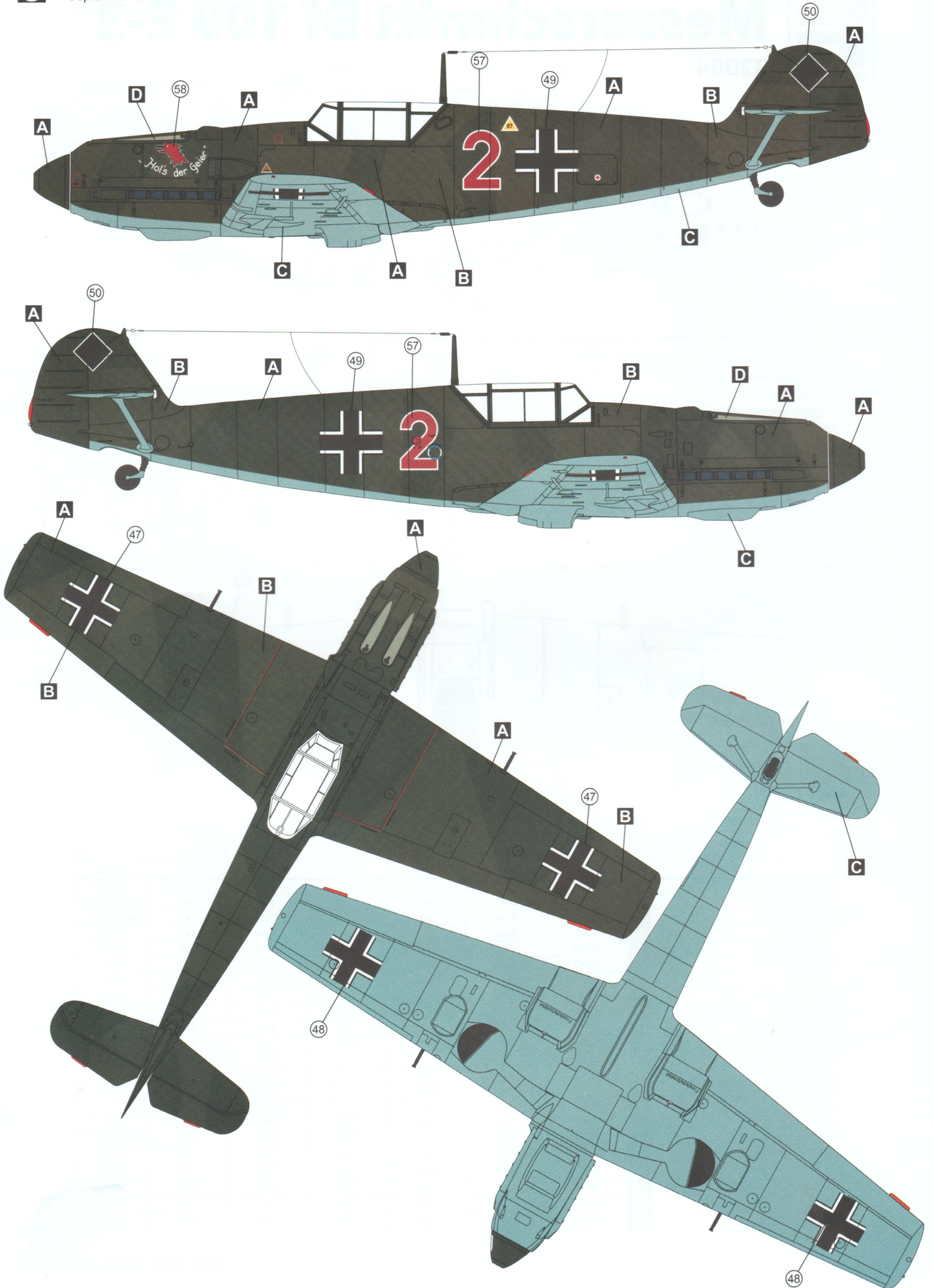

2

Bf 109 E-3, flown by Hptm. Hubertus von Bonin,
CO of I./JG 54, Eindhoven, the Netherlands,
early summer 1940

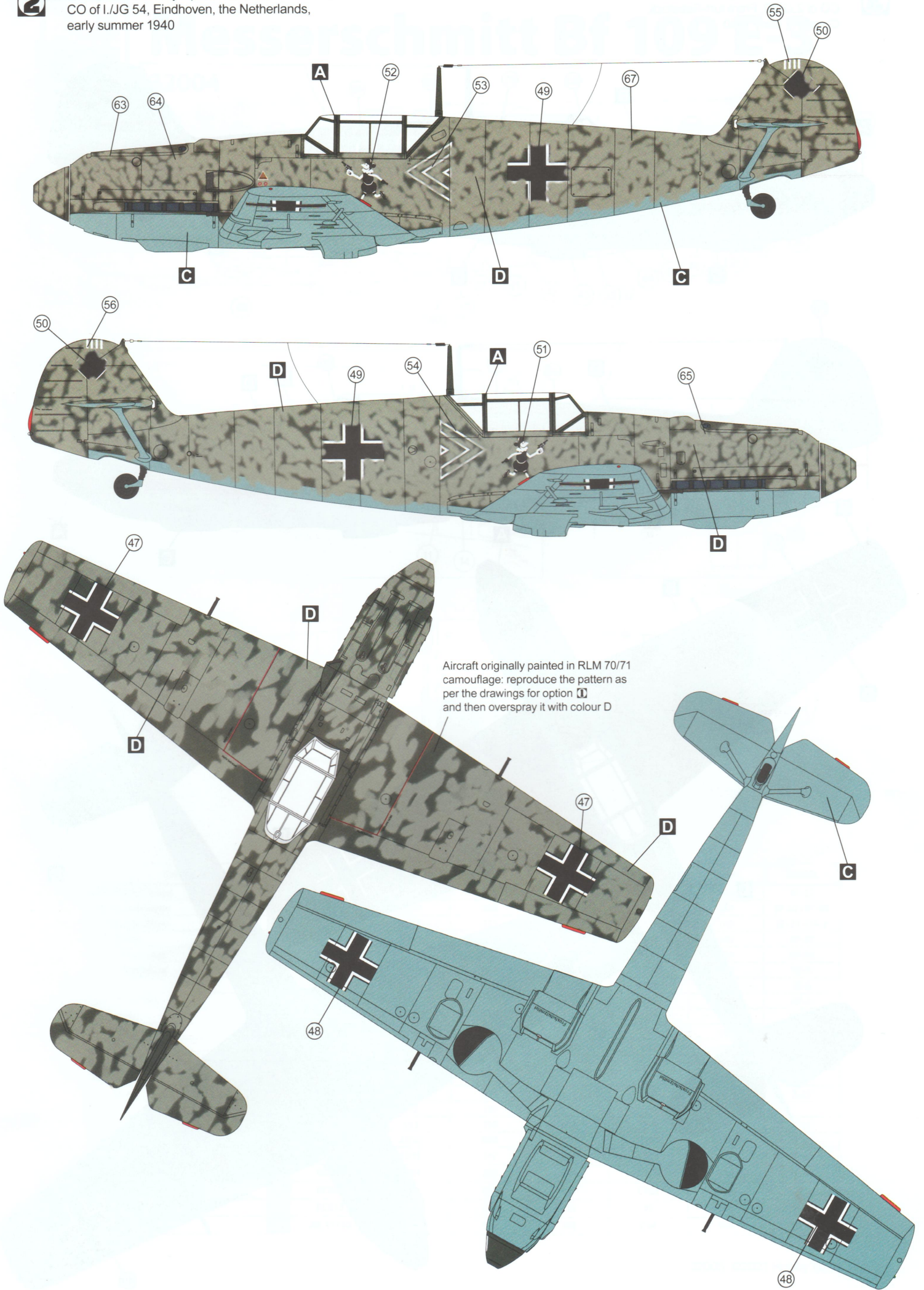

3 Bf 109 E-3, flown by Oblt. Karl-Heinz Greisert, CO of 2./JG 2, Frankfurt-Rebstock, Germany, early 1940

