

## AH-1S Cobra "IDF against terrorists"



Americké letectvo začalo záhy po zapojení se do války ve Vietnamu používat vrtulníky jako nosiče ofenzivní výzbroje. Již v letech 1962-63 podporovaly vrtulníkové výsadky palbou z kulometů, kanonů či raketometů v polních podmínkách vyzbrojené vrtulníky UH-1A. Úspěšné použití takto vyzbrojených vrtulníků ukázalo potřebu nového jednoúčelového útočného stroje s účinnou výzbrojí, co nejmenšími rozměry a velkou odolností proti poškození. Protože americká armáda měla o takový stroj enormní zájem, firma Bell zahájila vývoj takového stroje ve své režii. První projekt na základě typu Bell 47 nebyl úspěšný. Handicapoval ho zejména slabý pístový motor. Nový projekt firmy, označený D-262 postupně vyzrál do podoby označené model 209. Model 209 přebíral část konstrukčních řešení z vrtulníku UH-1C (ližiny podvozku, rotor, nosník ocasního rotoru apod.), měl však nový trup s kabinou pro dva členy osádky a s pylony pro podvěšenou výzbroj. Když armáda USA vypsala v roce 1965 soutěž na nový bitevní vrtulník, Bell model 209 ji s přehledem vyhrál. Hned v následujícím roce armáda objednala nejprve dva předseriové a pak stodeset seriových vrtulníků s armádním označením AH-1G Cobra. Další objednávky následovaly. Pro co nejrychlejší nasazení Cober ve Vietnamu vzniklo přeškolení středisko NETT (New Equipment Training Team) v jihovietnamském Vung Tau. První jednotkou nasazenou do boje na nových strojích byla 334. rota operující z Bien Hoa. Urychleně byly vyzbrojovány další jednotky. V průběhu bojů ve Vietnamu byly postupně zapracovány na vyráběných vrtulnicích poznatky a požadavky letců. První vrtulníky měly vyrovnávací rotor vlevo, pozdější vpravo, byly montovány zesílené ližiny podvozku, příďovou věž TAT-102 s jedním rotačním kulometem Minigun nahradila věž M-28 s Minigunem a granátometem (nejčastěji). Na závěsníky byla zavěšována pestrá výzbroj od různých raketových bloků, přes pouzdra s kulometry Minigun až po komplet M-35 (kanon Vulcan s nábojovými schránkami). Záleželo na úkolu, který měl vrtulník plnit a také na tom, jakou výzbroj pilot preferoval. V roce 1972 se na vrtulnicích objevily deflektory výtokových plynů jako reakce na tepelně naváděné střely ve výzbroji komunistické vietnamské armády a Vietkongu. Ve Vietnamu se Cobry nesporně osvědčily. Používaly je nejen vrtulníkové jednotky armády, ale i jednotky US MARINES. US MARINES bylo také s AH-1G spokojeno, ale pro provoz nad mořem a lodích požadovalo dva motory, což vedlo k vývoji dvoumotorových verzí, první z nich byla AH-1J. AH-1G Cobra byly exportovány jen do Španělska a Izraele. Ve Španělsku je používalo námořnictvo, v Izraeli měly AH-1G problémy s prašným a horkým podnebím. Izrael potřeboval vrtulníky pro boj s tanky a proto další objednávky byly směřovány na protitankové verze AH-1Q/S. Na tyto verze bylo také přestavěno mnoho amerických AH-1G, včetně strojů stažených z Vietnamu. Koncepce AH-1G Cobra se stal etalonem pro bitevní vrtulník. Další verze tohoto vrtulníku létají dodnes jak v USA, tak ve výzbroji mnoho jiných armád.

TTD:

průměr hl. rotoru: 13,4 m, délka trupu: 13,5 m, průměr vyrovnávacího rotoru: 2,6 m, max. rychlost: 276 km/h, dostup: 3871 m, dolet: 580 km



Soon after its engagement in the Vietnam War the US Air Force started to use helicopters as offensive weapons platforms. Even during 1962-63 period field modified UH-1A helicopters supported the troops' landing with machineguns, cannons and rockets. The success of such equipped helicopters showed the need of a new, single purpose attack machine of the smallest possible dimensions, equipped with effective firepower and high damage resistance. Bell Company started to develop of specified helicopter on their expenses since the US Army had immense interest in such machine. The first project based on type Bell 47 was not successful. Its main downfall was a weak piston engine. The new project designated D-262 grew into the late appearance designated as model 209. The model 209 took over some of the structural solutions from UH-1C helicopter (undercarriage skis, main rotor, tail boom, etc.) but featured new fuselage that housed cockpit for crew of two and stub wings for carrying external armament. When in 1965 the US Army issued a specification calling for new attack helicopter, Bell model 209 was a clear winner. The very next year the US Army ordered, initially two pre-production machines and then 110 production helicopters under army designation AH-1G Cobra. Additional orders followed the original one. To speed up the Cobra deployment into Vietnam a NETT (New Equipment Training Team) training centre was founded in Vung Tau in South Vietnam. The first unit that flew the new machines in combat was the 334th platoon based at Bien Hoa. Other units were rapidly equipped with Cobras. The knowledge and pilots' requirements during the fights in Vietnam were incorporated into the production of the helicopters. The first helicopters featured the tail rotor on the left side, later relocated to the right side, strengthened undercarriage skis were adopted, the original nose mounted TAT-102 turret with Minigun was replaced by M-28 turret equipped with Minigun and grenade launcher (most often). The stub wings were capable of carrying variety of weapons; from various rocket blocks, Minigun pods to M-35 pod (Vulcan cannon with ammunition boxes). All depended on the mission purpose and pilot's preferences. As a reaction to the heat seeking missiles used by the Vietnamese Army and the Viet Cong starting in 1972 the helicopters were equipped with exhaust gas deflectors. Cobras indisputable prove to be effective in Vietnam. They were used not only by US Army helicopter units but also by the US Marines that were also satisfied with AH-1G but for the shipboard and over sea operations which required a helicopter with two engines. This requirement led to the development of twin-engined version AH-1J. AH-1Gs were exported only to Spain and Israel. Cobras were used by the Spanish Navy. Israeli Cobras faced troubles with hot and dusty environment. Israel needed tank buster helicopters and therefore subsequent orders were placed for the anti-tank version AH-1Q/S. Plenty of the US AH-1Gs were modified to this version, including the machines withdrawn from Vietnam. The conception of AH-1G Cobra became a standard for attack helicopters. Subsequent versions of this helicopter are still in use not only in the USA but also in many other armies.

TTD:

Main rotor diameter: 13.4 m, Fuselage length: 13.5 m, Tail rotor diameter: 2.6 m, Max. speed: 276 kmh, Service Ceiling: 3,871 m, Range: 580 km

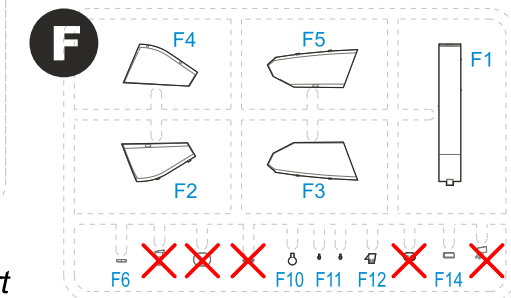
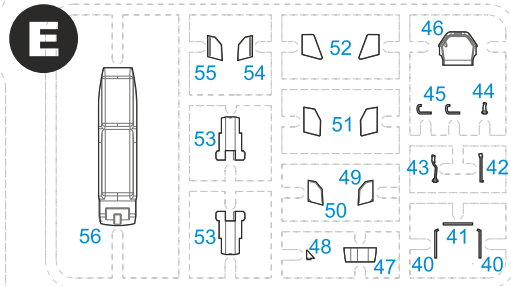
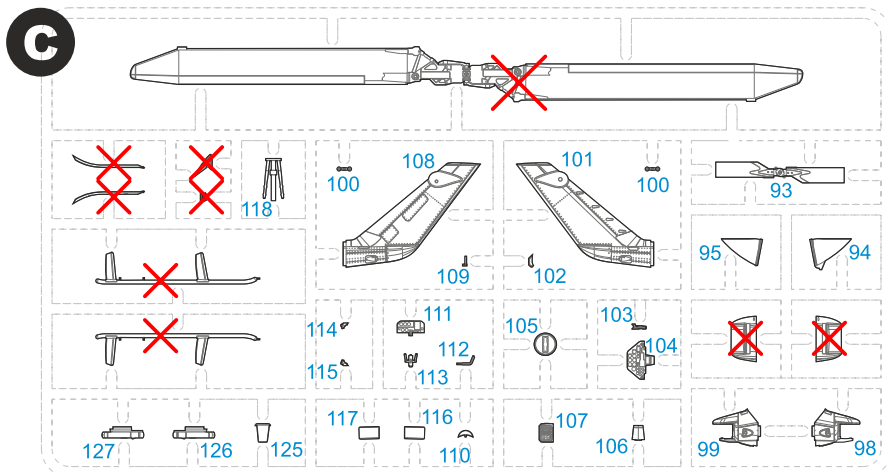
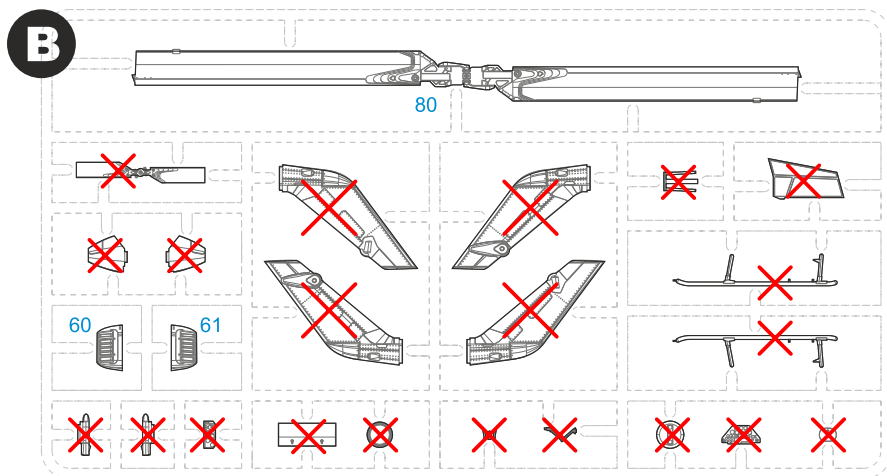
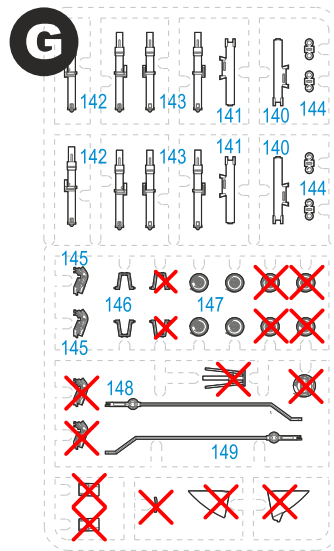
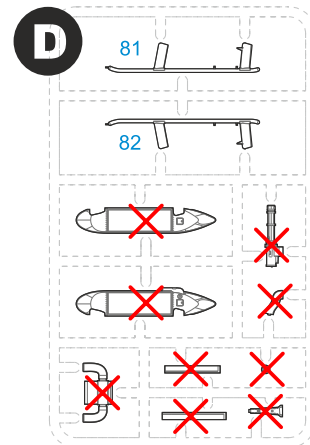
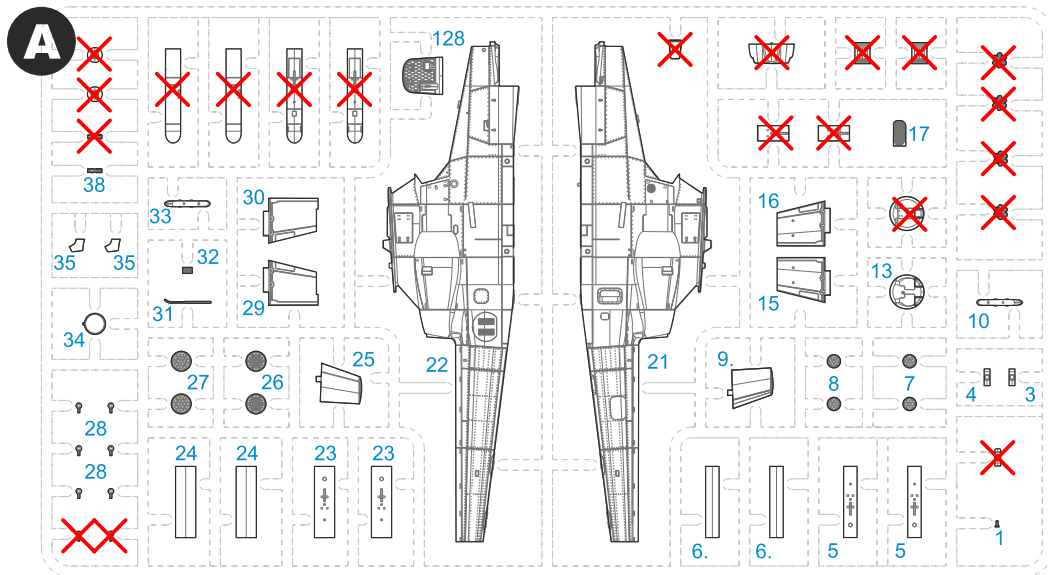

PUR parts 

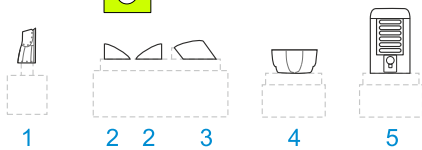

 **Tento díl nepoužít**  
**Do not use this part**

**CAMO. D:**



For complete camouflage scheme D of machine no. 326 from May 1979, please visit our website [www.cmkkits.com](http://www.cmkkits.com) or [www.mpmkits.com](http://www.mpmkits.com).  
Kompletní kamufláž D pro stroj č. 326 z května 1979 naleznete na našich stránkách [www.cmkkits.com](http://www.cmkkits.com) nebo [www.mpmkits.com](http://www.mpmkits.com).

**SYMBOLS**

 **MOŽNOST VOLBY**  
OPTIONAL  
NACH BELIEBEN  
OPTION

 **POUŽÍT KYANOAKRYLÁTOVÉ LEPIDLO**  
INSTANT CYANOACRYLATE GLUE  
ZYANOAKRYLÁTKLEBER  
ADHÉSIF CYANOACRYLAT

 **OHNOUT**  
BEND  
BIEGEN  
COURBER

 **ZHOTOVIT NOVÉ**  
SCRATCH BUILD  
FERTIGSTELLEN  
ACHEVER

 **ŘEZAT/VRTAT**  
CUT OFF/DRILL  
ENTFERNEN  
DETACHER

 **NATRÍT**  
COLOUR  
FARBEN  
PEINDRE

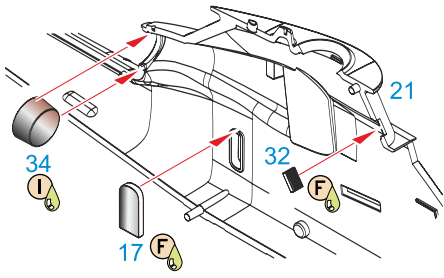
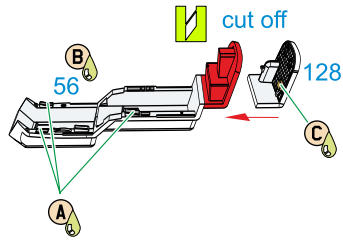
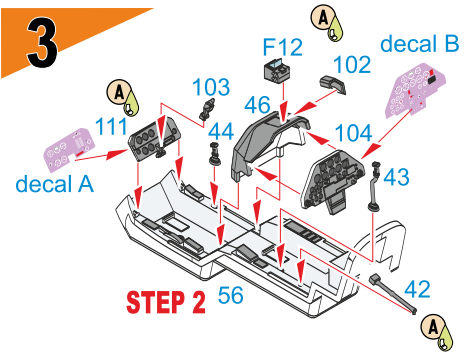
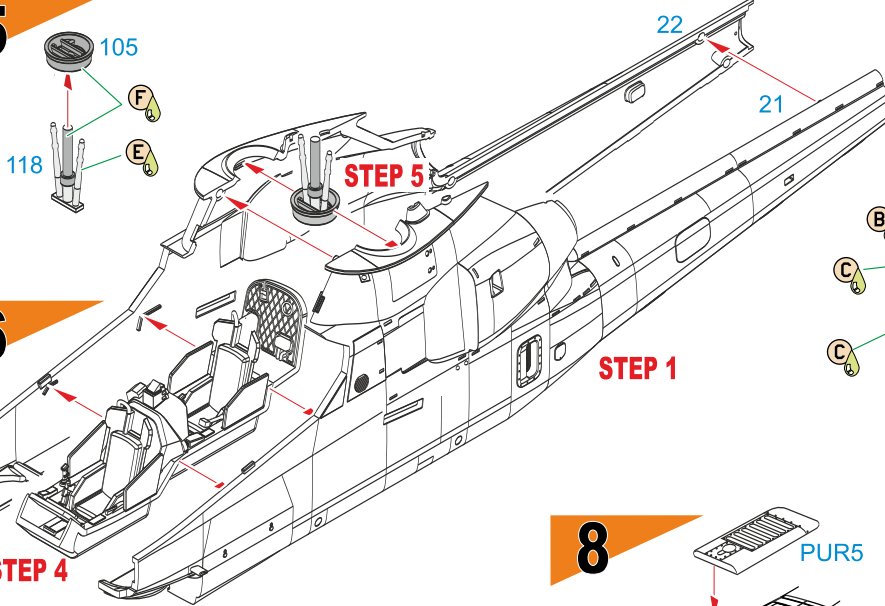
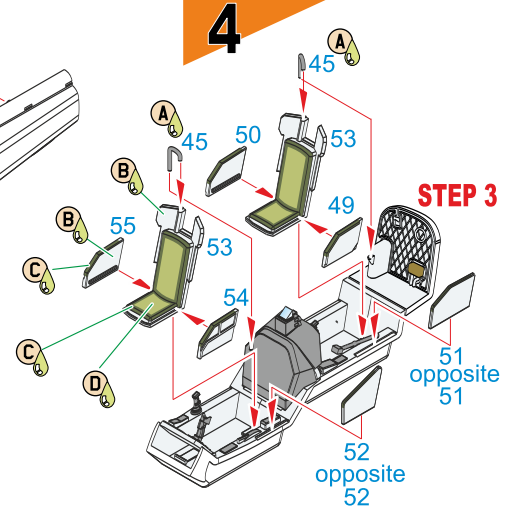
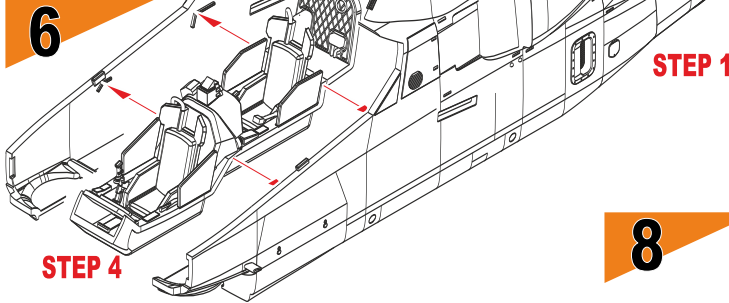
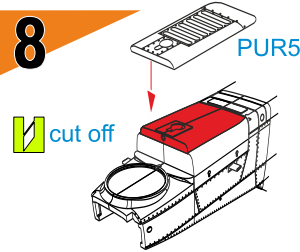
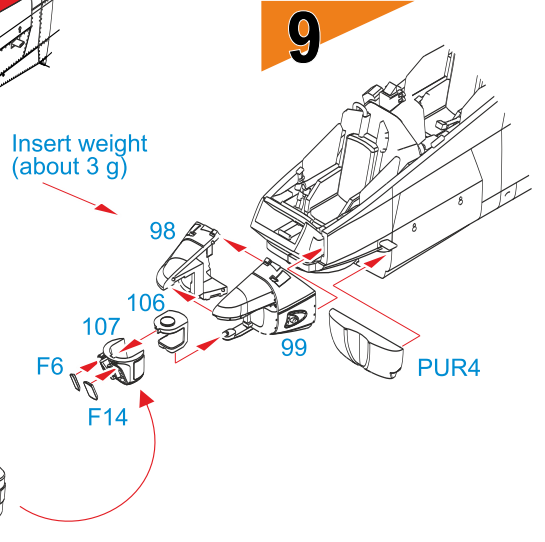
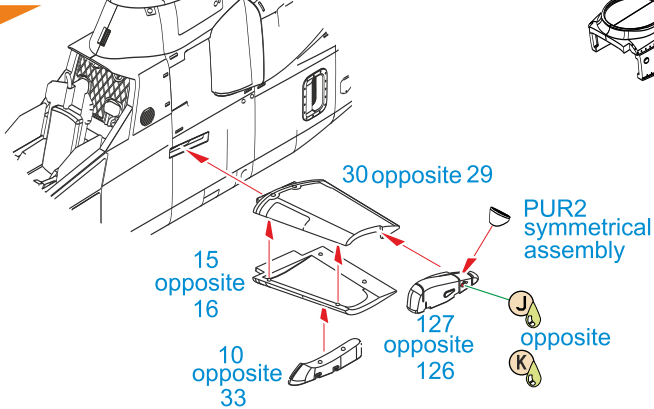
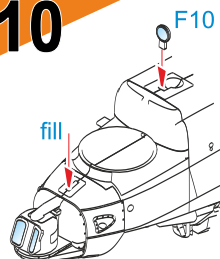
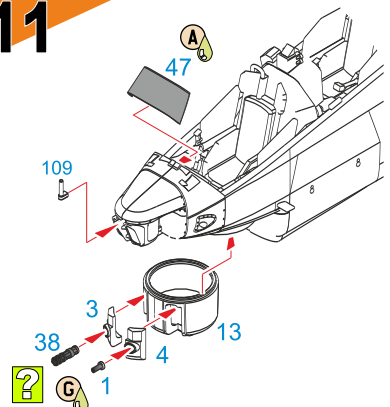
**1****2****3****5****4****6****8****9****7****10****11****Barvy GUNZE/ GUNZE Colour No.**

A	Černá / BLACK	H12/C33
B	Tm. rascí šedá / DK.GULL GRAY	H317/C317
C	Olivově zelená / OLIVE GREEN	H52/C12
D	Světle zelená / LIGHT GREEN	H26/C66
E	Hliník / ALUMINIUM	H8/C8
F	Ocelová / STEEL	H18/C28
G	Dělovina / GUNMETAL	H28/C78
H	Tmavá mosaz / DK.BRASS	MC219
I	Opálený kov / BURNT METAL	H76/C61
J	Červená čirá / CLEAR RED	H90/C47
K	Modrá čirá / CLEAR BLUE	H93/C50
L	Barva pneu / TIRE BLACK	H77/C137
M	Světle šedá / LT.GRAY	H21/C69
N	Červená / RED	H3/C3

# 12

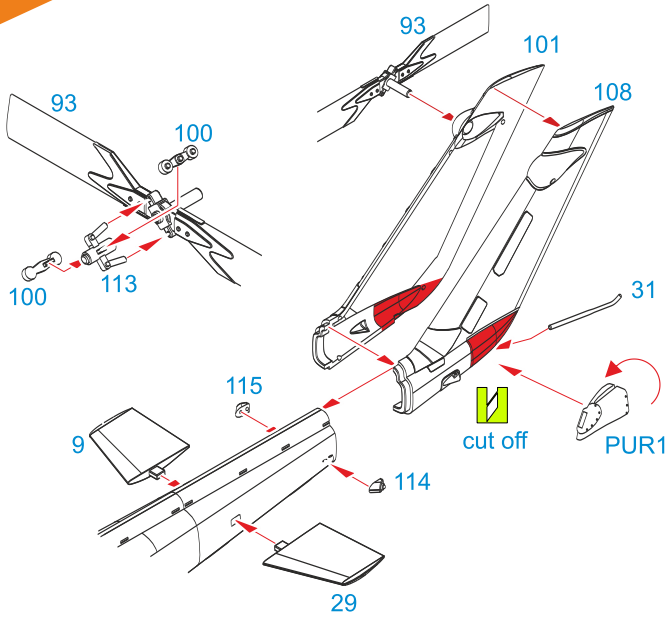

# 13

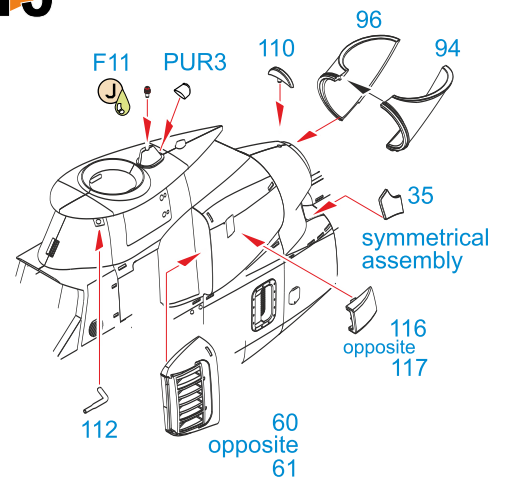

# 14

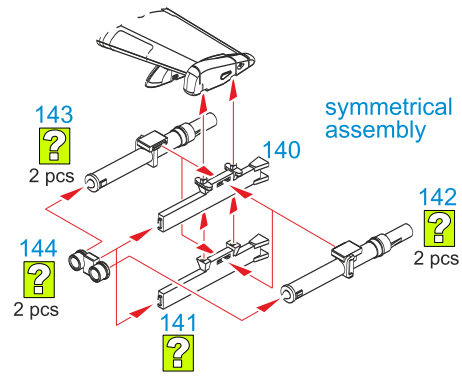

# 15

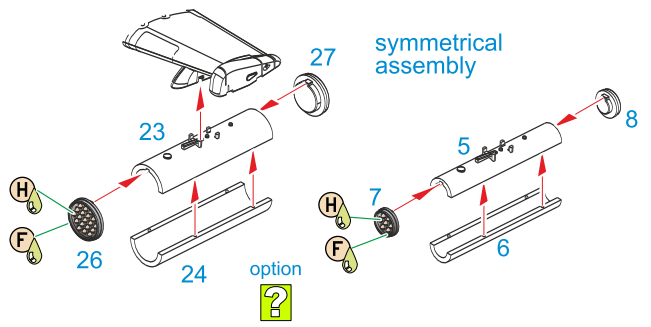

# 17

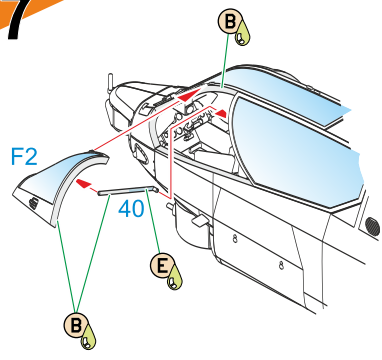

# 16

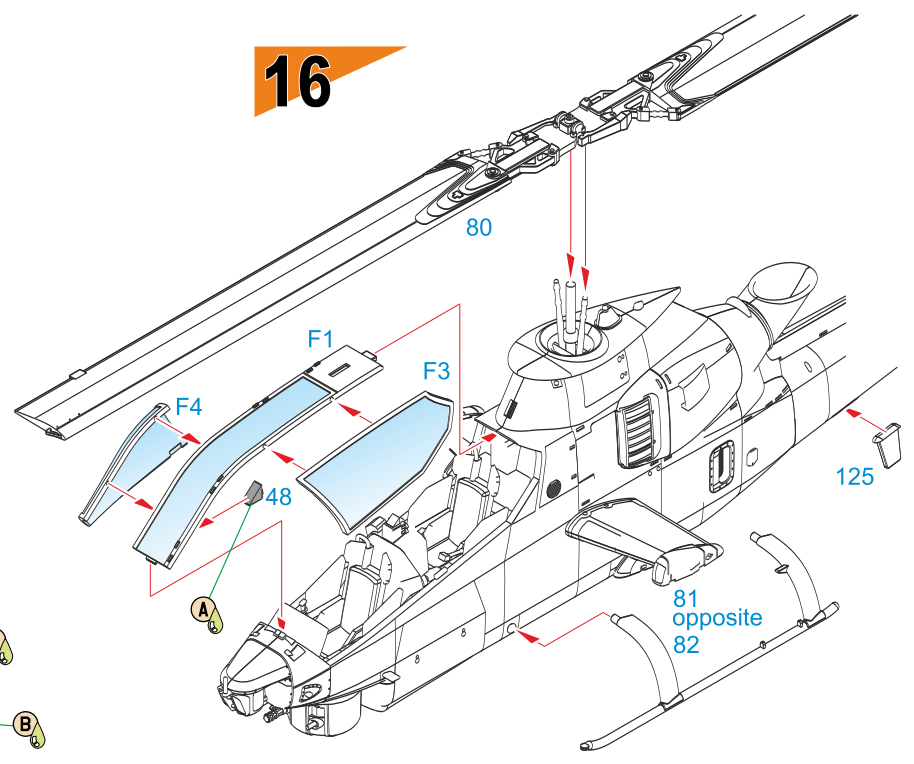

# 18

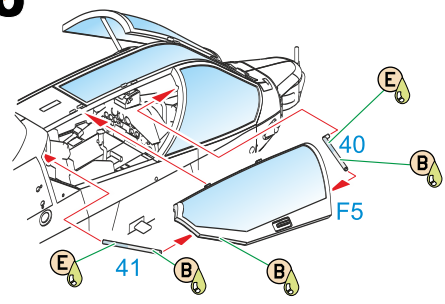

19

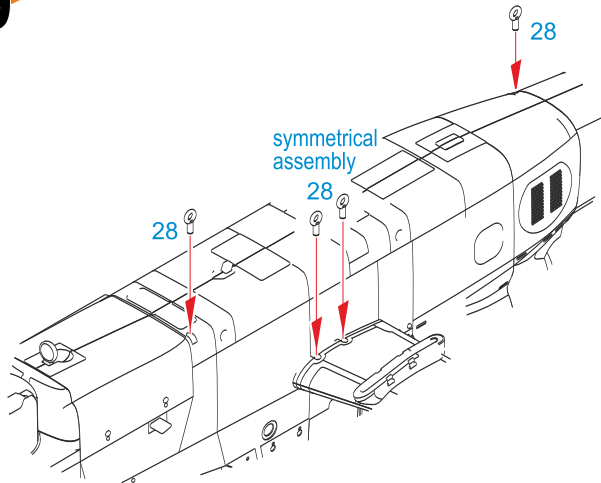

20

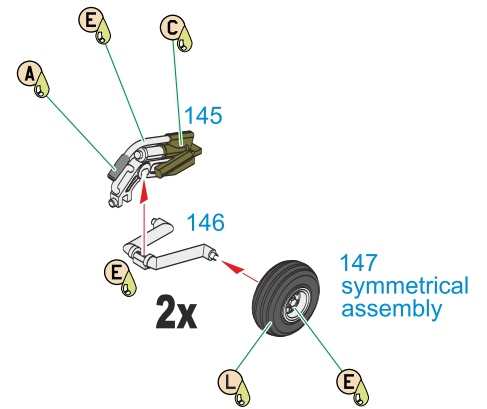

21

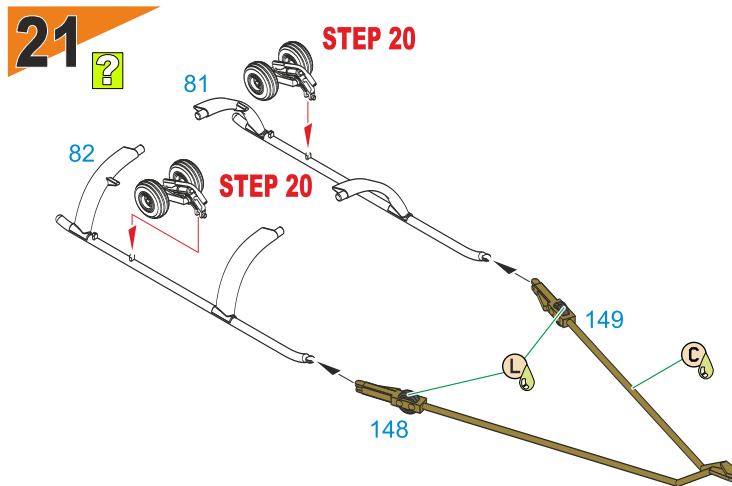

Pokud chcete vylepšit svůj model AH-1S Cobra, zakupte si zvlášť prodávané barvené lepty MPM Prod. kat. čísla K72030 a resinové sedačky Q72209. Žádejte u svého obchodníka nebo je objednávejte na [www.cmkkits.com](http://www.cmkkits.com) nebo [www.mpmkits.com](http://www.mpmkits.com).

If you want to enhance the level of details of your AH-1S Cobra purchase separately sold MPM Prod. colour photo-etched parts cat. no. K72030 and resin seats Q72209. Ask your local retailer or order them at [www.cmkkits.com](http://www.cmkkits.com) or [www.mpmkits.com](http://www.mpmkits.com).

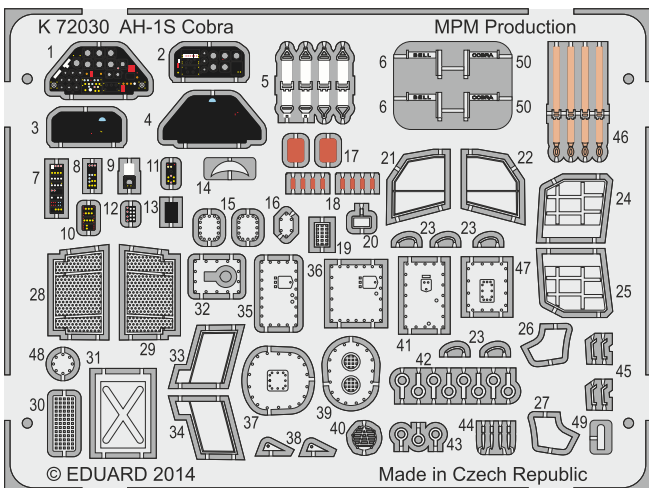

AH-1S Tzefa A, č.326, Southern Cobra Sqn. (bývalá First Attack Helicopter Sqn.), Chel Ha'Avir (izraelské letectvo), základna Palmachim, Izrael, červenec 1982, během operace Mír pro Galileu.

AH-1S Tzefa A, No.326, Southern Cobra Sqn., (ex-First Attack Helicopter Sqn.), Chel Ha'Avir (Israeli Defense Force / Air Force), Basis Palmachim, Israel, July 1982, during the Peace for Galilee operation.

CAMO. A

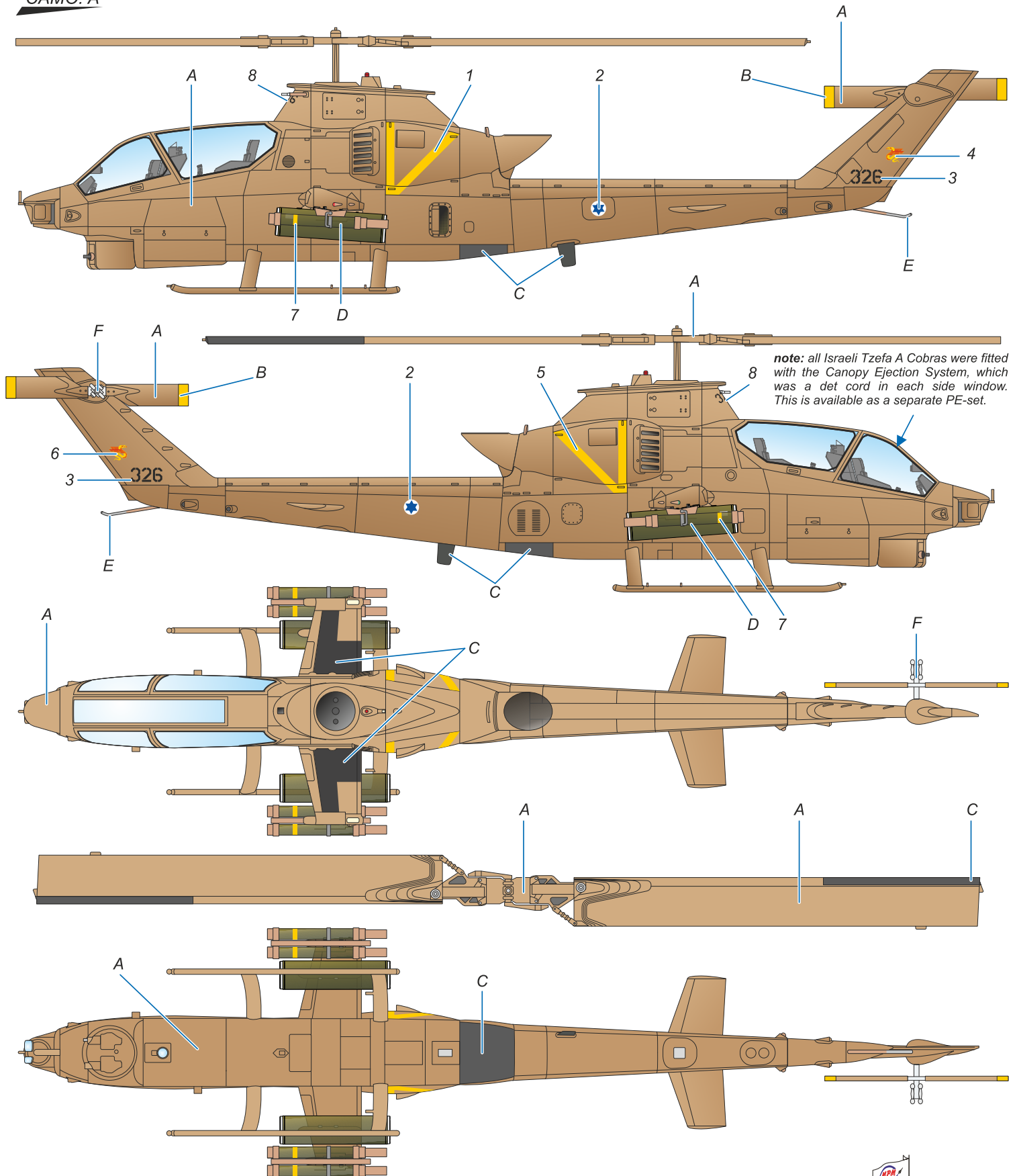

- |  |                                     |                                    |                                      |                                       |   |
|--|-------------------------------------|------------------------------------|--------------------------------------|---------------------------------------|---|
| <b>A</b> hnědá<br>Dark Tan<br>FS 20095<br>approx. H66/C119 | <b>B</b> žlutá<br>Yellow<br>H04/C04 | <b>C</b> černá<br>Black<br>H12/C33 | <b>D</b> olivová<br>Olive<br>H52/C12 | <b>E</b> barva kovu<br>NMF<br>H08/C08 | <b>F</b> světle šedá<br>Light Gray<br>H21/C69 |
|--|-------------------------------------|------------------------------------|--------------------------------------|---------------------------------------|---|



AH-1S Tzefa A, č.315, First Attack Helicopter Squadron, Chel Ha'Avir (izraelské letectvo), základna Palmachim, Izrael, 1982, během války v Libanonu.

AH-1S Tzefa A, No.315, First Attack Helicopter Squadron, Chel Ha'Avir (Israeli Defense Force / Air Force), Basis Palmachim, Israel, 1982, during the Lebanon War

**CAMO. B**

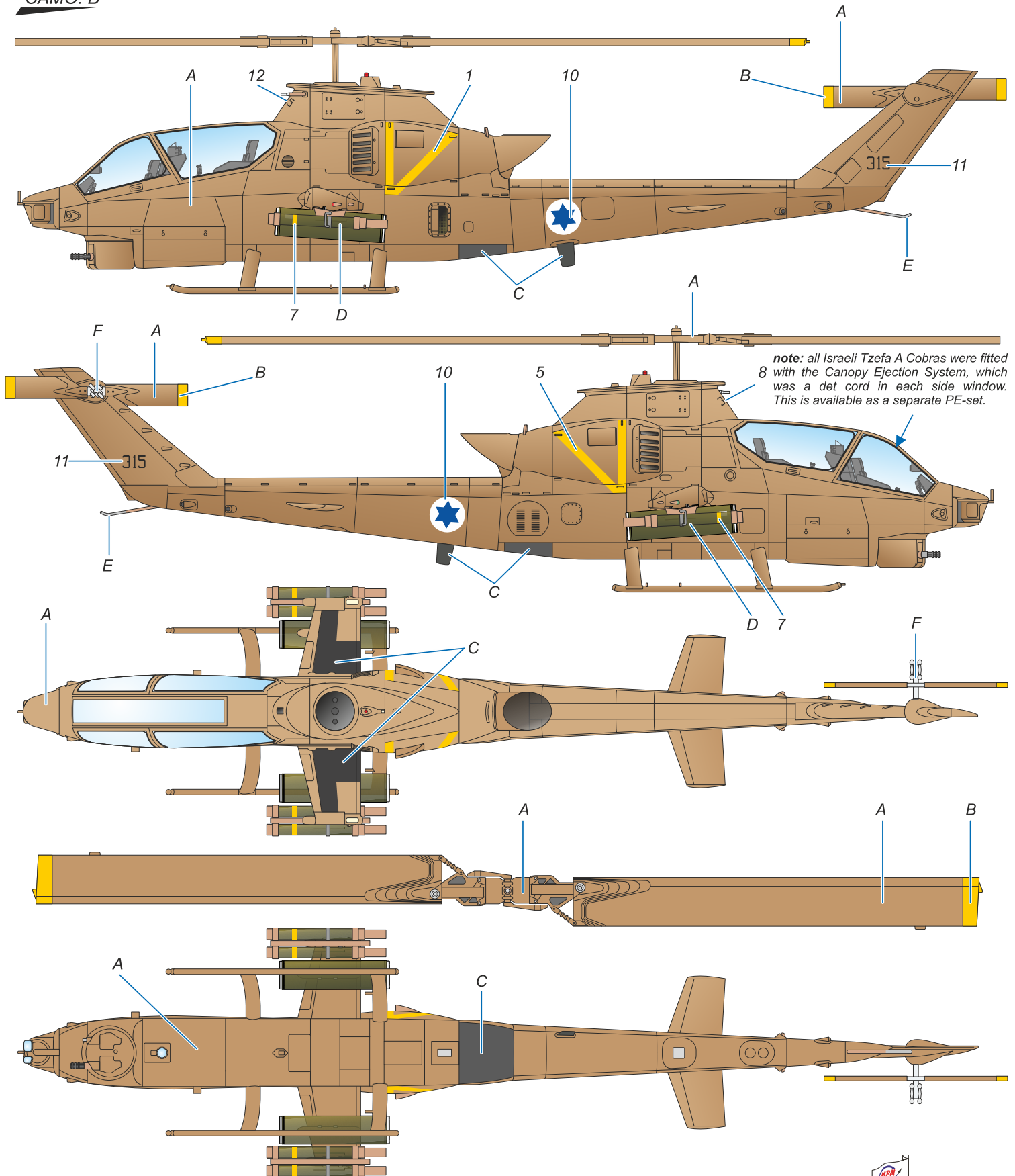

- |  |                                     |                                    |                                      |                                       |   |
|--|-------------------------------------|------------------------------------|--------------------------------------|---------------------------------------|---|
| <b>A</b> hnědá<br>Dark Tan<br>FS 20095<br>approx. H66/C119 | <b>B</b> žlutá<br>Yellow<br>H04/C04 | <b>C</b> černá<br>Black<br>H12/C33 | <b>D</b> olivová<br>Olive<br>H52/C12 | <b>E</b> barva kovu<br>NMF<br>H08/C08 | <b>F</b> světle šedá<br>Light Gray<br>H21/C69 |
|--|-------------------------------------|------------------------------------|--------------------------------------|---------------------------------------|---|



AH-1S Tzefa A, č.318, First Attack Helicopter Squadron, Chel Ha'Avir (izraelské letectvo), základna Tel Nof, Izrael. V prosinci 1978 během letu v tomto vrtulníku seznámil velitel squadrony Lt.Col. Joni Gill náčelníka štábu izraelské armády Lt.Gen. Rafaela Eitana s bojovými schopnostmi kober.

AH-1S Tzefa A, No.318, First Attack Helicopter Squadron, Chel Ha'Avir (Israeli Defense Force / Air Force), Basis Tel Nof, Israel. In december 1978, Squadron Commander Lt.Col. Yoni Gill presented the helicopter's capabilities to IDF Chief-of-Staff Lt.Gen. Rafael Eitan during a familiarization flight in this machine.

**CAMO. C**

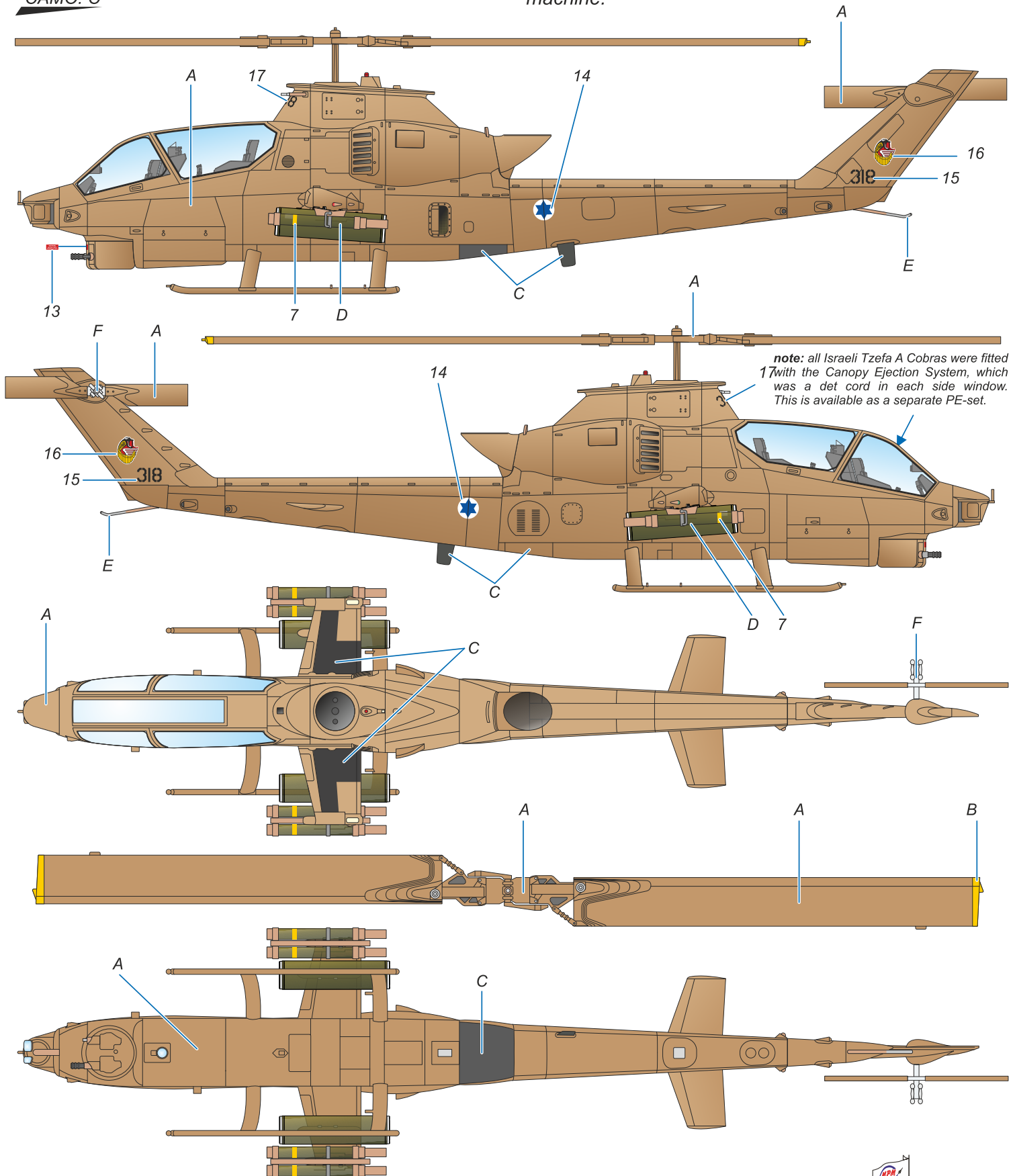

**note:** all Israeli Tzefa A Cobras were fitted with the Canopy Ejection System, which was a det cord in each side window. This is available as a separate PE-set.

- |  |                                     |                                    |                                      |                                       |   |
|--|-------------------------------------|------------------------------------|--------------------------------------|---------------------------------------|---|
| <b>A</b> hnědá<br>Dark Tan<br>FS 20095<br>approx. H66/C119 | <b>B</b> žlutá<br>Yellow<br>H04/C04 | <b>C</b> černá<br>Black<br>H12/C33 | <b>D</b> olivová<br>Olive<br>H52/C12 | <b>E</b> barva kovu<br>NMF<br>H08/C08 | <b>F</b> světle šedá<br>Light Gray<br>H21/C69 |
|--|-------------------------------------|------------------------------------|--------------------------------------|---------------------------------------|---|

