

Lynx Mk.88 interior S.A.

1/48 scale detail set for AIRFIX kit • sada detailů pro model 1/48 AIRFIX

eduard

49 625

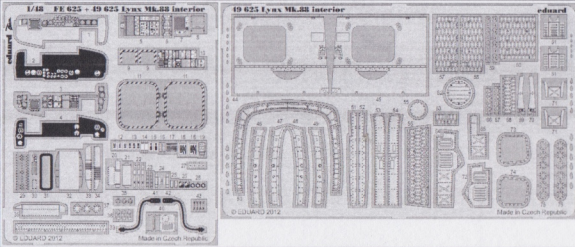

- ★ APPLY EXPRESS MASK AND PAINT BEFORE GLUING
POUŽÍT EXPRESS MASK NABARVIT PŘED SLEPENÍM
- ☉ SYMMETRICAL ASSEMBLY
SYMETRICKÁ MONTÁŽ
- ☒ REMOVE
ODSTRANIT
- ☒ GRIND
OBROUSIT
- ☒ DRILL HOLE
VRTAT OTVOR
- ☒ BEND
OHNOUT
- ☒ OPTION
VOLBA
- ☒ REPLACE
NAHRADIT

ORIGINAL KIT PARTS
PŮVODNÍ DÍLY STAVEBNICE
PHOTO-ETCHED PARTS
LEPTANÉ DÍLY
PARTS TO BE REMOVED
DÍLY K ODSTRANĚNÍ
FILL
TMELIT

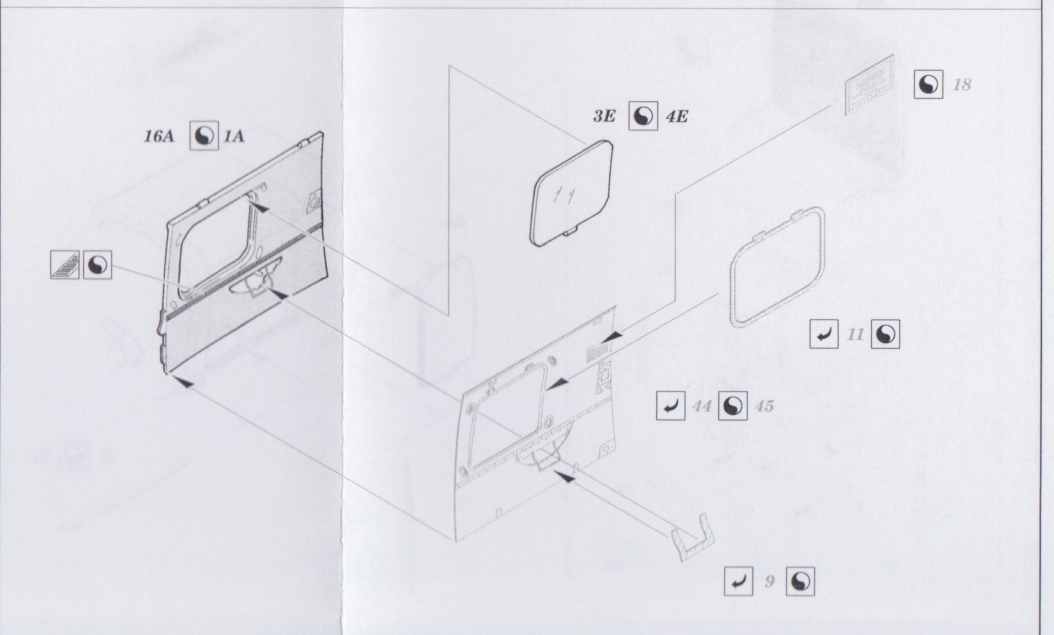
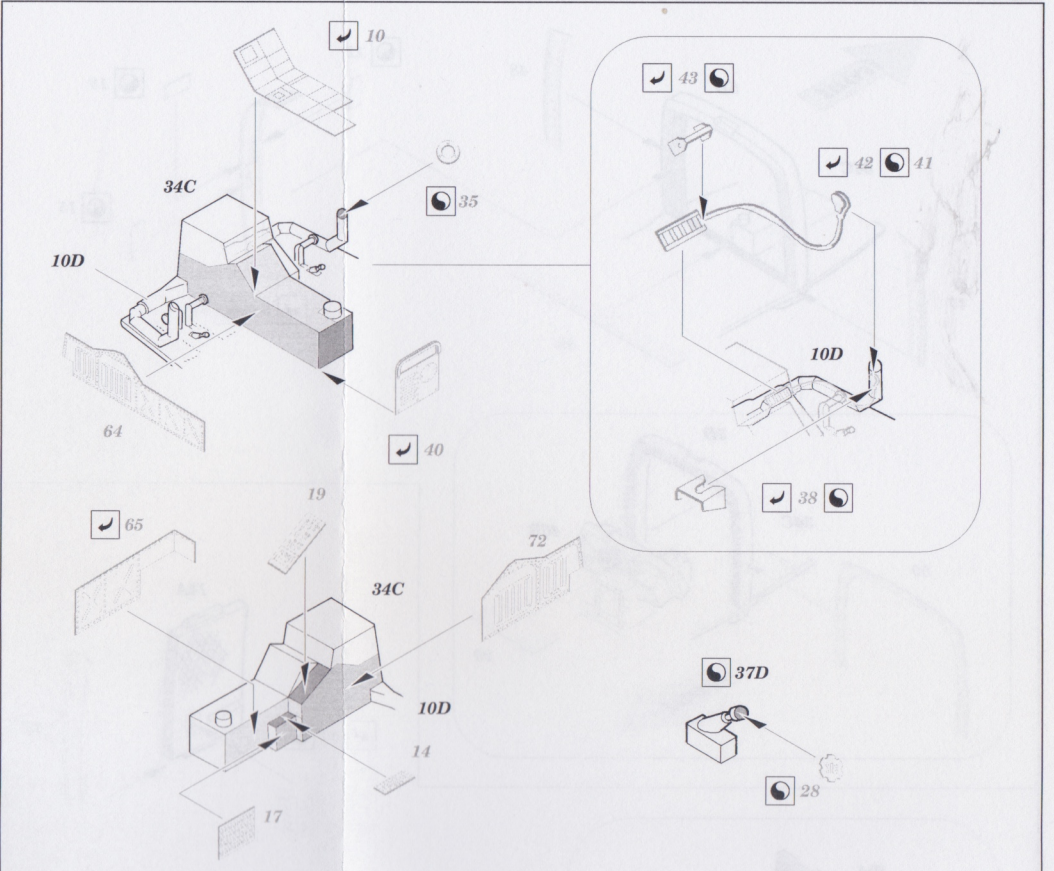
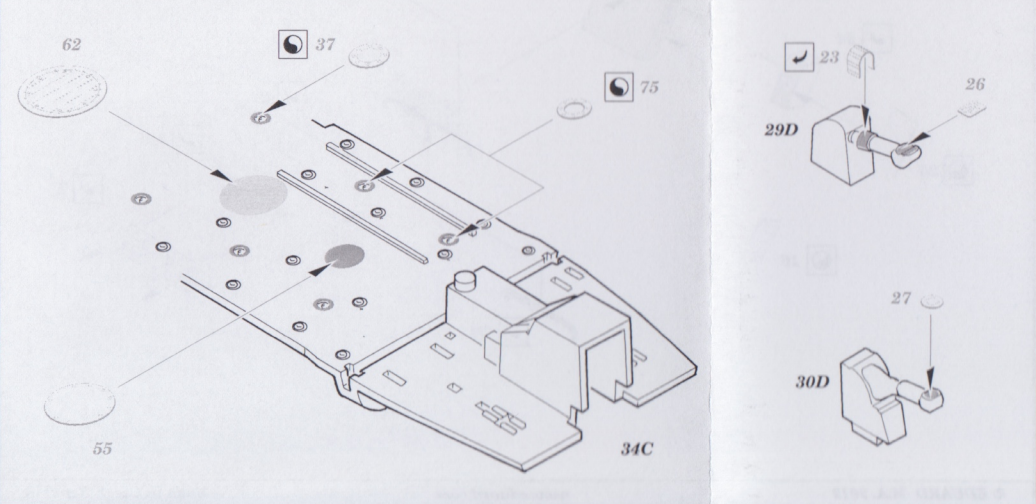
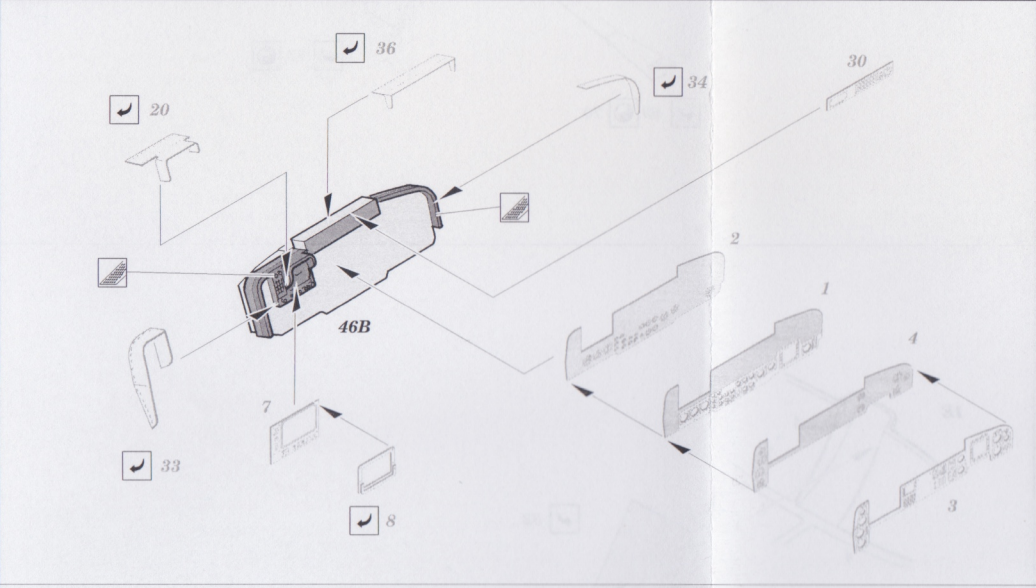

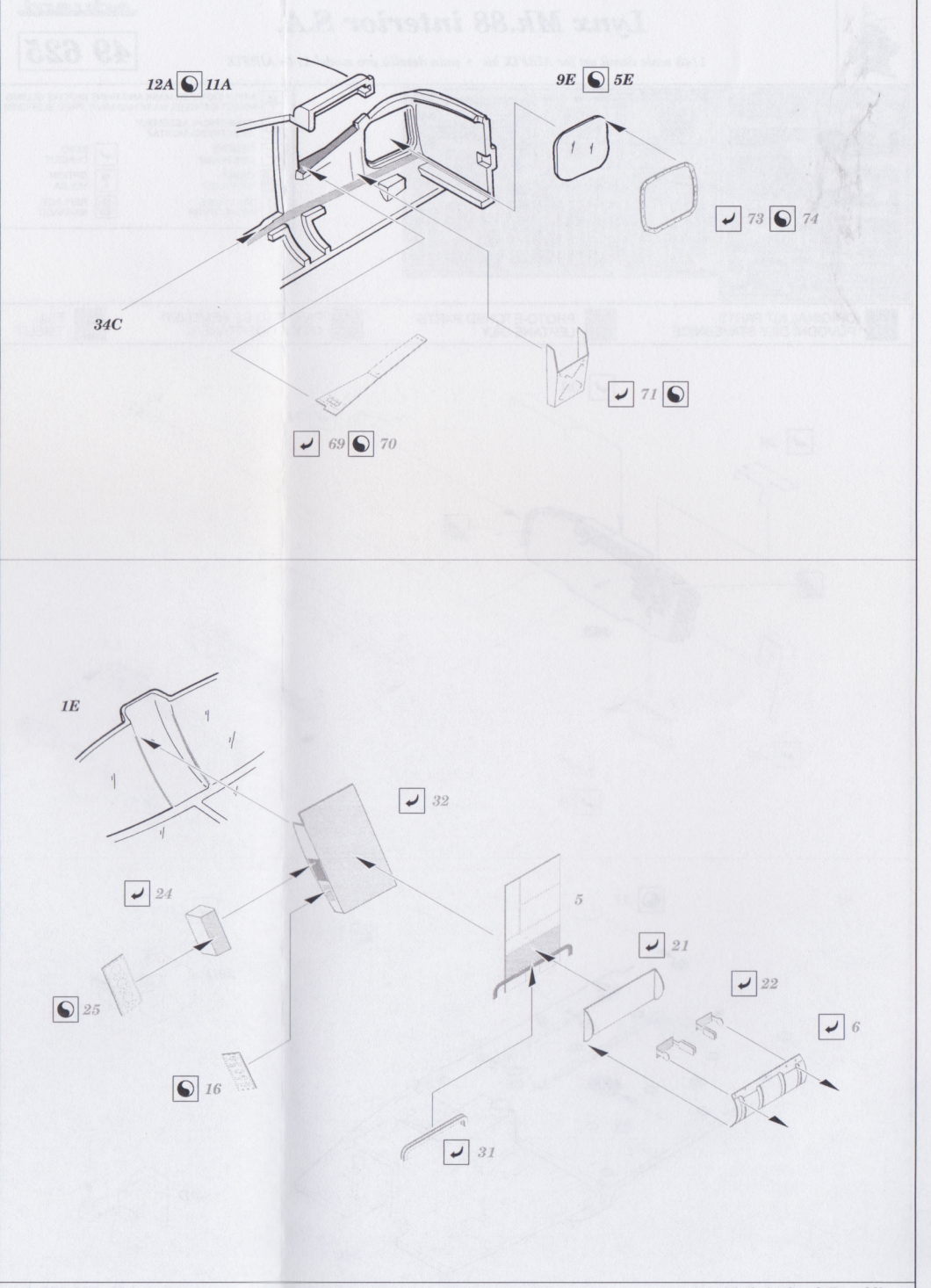
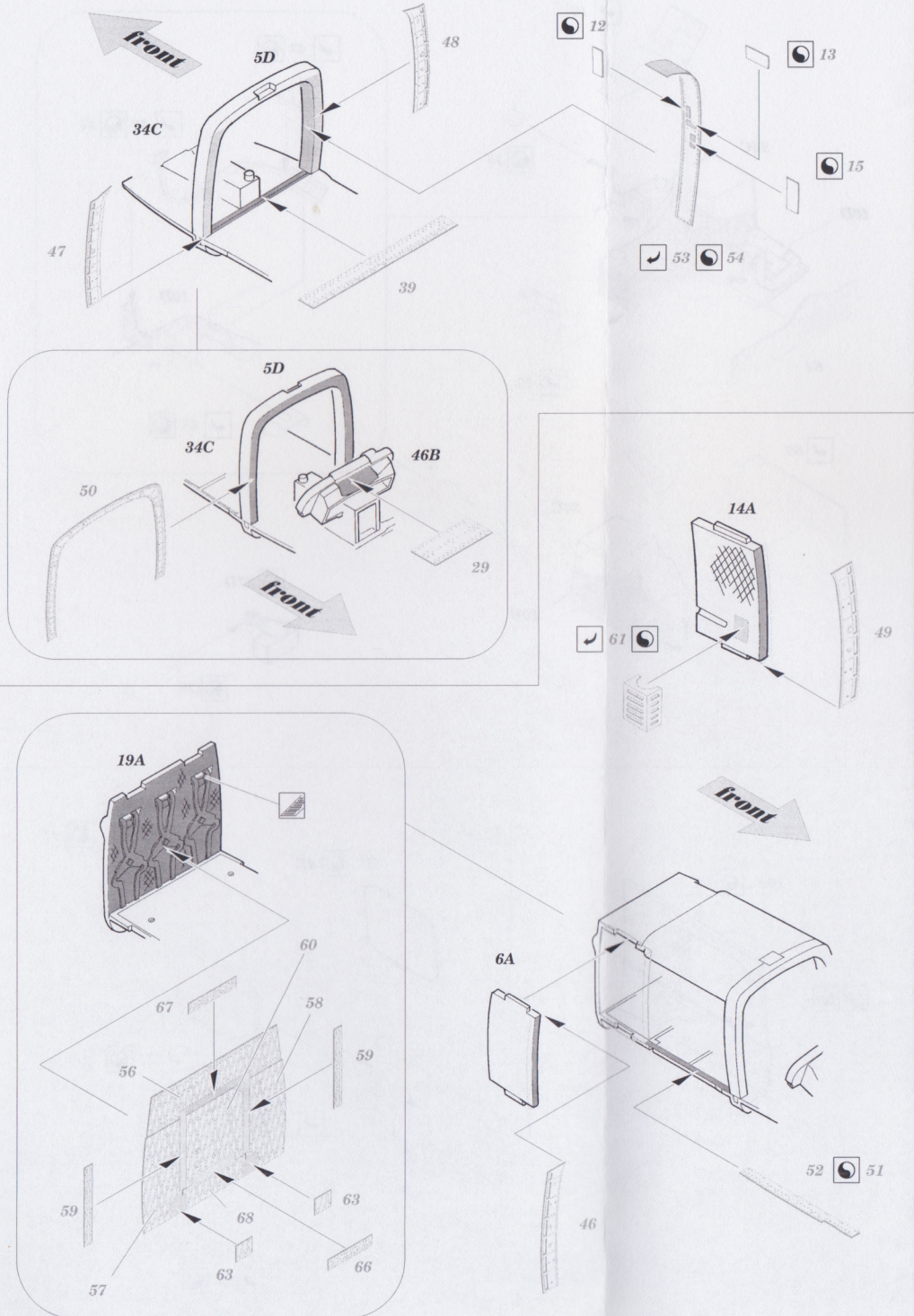

For further detail sets look for eduard 49 624 Lynx MK.88 seatbelts and
48 752 Lynx Mk.88 exterior
(not included in this set)

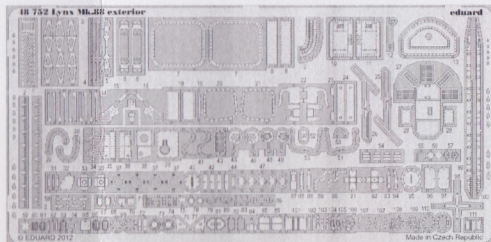
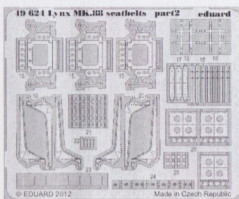
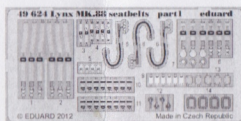

PARTS WITH GLUE • DÍLY OPATŘENÉ LEPIDLEM

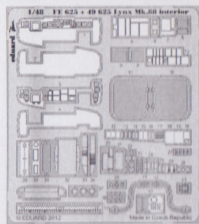

1. Separate the etched components from their frames on the protective paper. Removal from the paper is done only after separation of the parts from the frames.

1. Samolepicí díly odděluje od rámečku na podkladovém papíru. Po oddělení je sejměte z krycího papíru.



2. Do not inadvertently place etched components on an unwanted surface. Attempts to remove will result in damage to your part.

2. Nepokládejte samolepicí díly na volné plochy. Pokud je omylem přilepíte, při pokusu o odlepení dojde k poškození dílu.

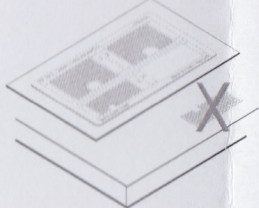

3. Do not touch the adhesive areas of the etched components.
3. Nesahejte na části dílů, na kterých je naneseno lepidlo.

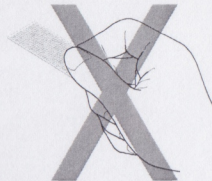

4. Hold the parts by the edges, or at areas free of adhesive.

4. Samolepicí díly berte za hrany nebo za části, na kterých není naneseno lepidlo.



5. Lightly place the component in the desired location and position. Adjust as required. The component will be permanently affixed when pressed onto its intended location, its location can be adjusted.

5. Díl lehce položte do pozice, ve které má být nalepen. Upravte přesnou pozici a přimáčkněte. Díl dokonale přilne až po přimáčknutí, před přimáčknutím lze dílem opatrně manipulovat.

