



T147601

'32 FORD COUPE

IMPORTANT!

READ THESE POINTS BEFORE YOU BEGIN

- 1 This kit may be built more than one way. Decide on which version you wish to build before final assembly.
- 2 "TEST FIT" all parts before cementing. Cement all parts unless otherwise indicated by the instructions.
- 3 Use paint and cement made for styrene plastic only. Trim excess plastic from parts before joining.
- 4 Paint all sub-assemblies before attaching chrome parts.
- 5 Scrape chrome and paint away from surfaces to be cemented together.
- 6 Follow all of the numbers on the instruction sheet beginning with (Number one).

1. ENGINE

CHEVY

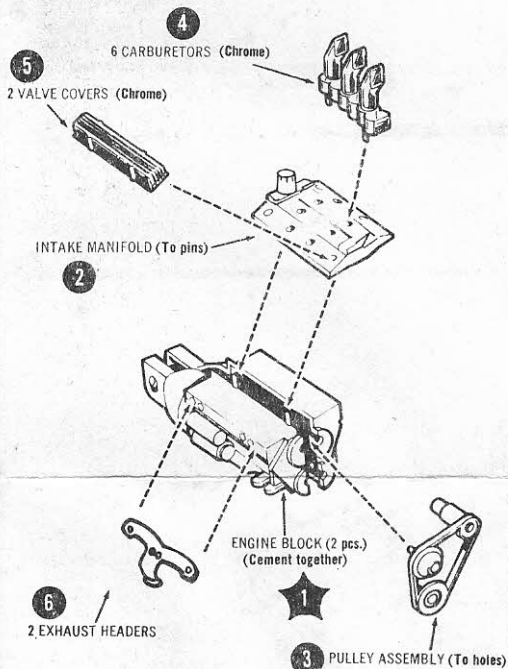

STOCK "FLATHEAD"

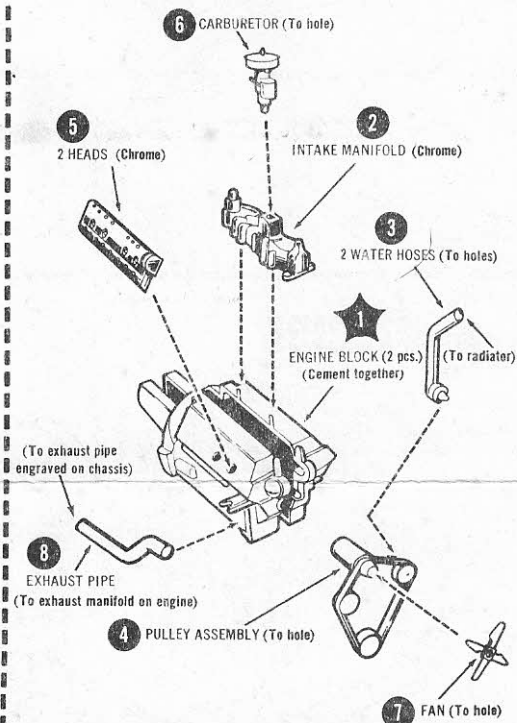

2. WHEELS

STOCK

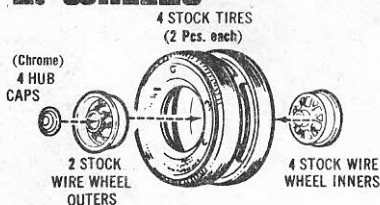

STREET ROD

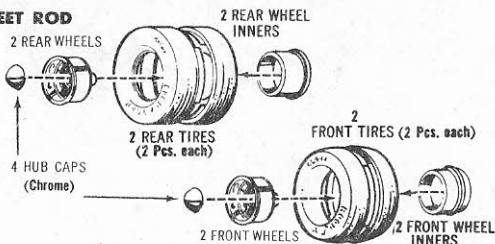

3. CHASSIS

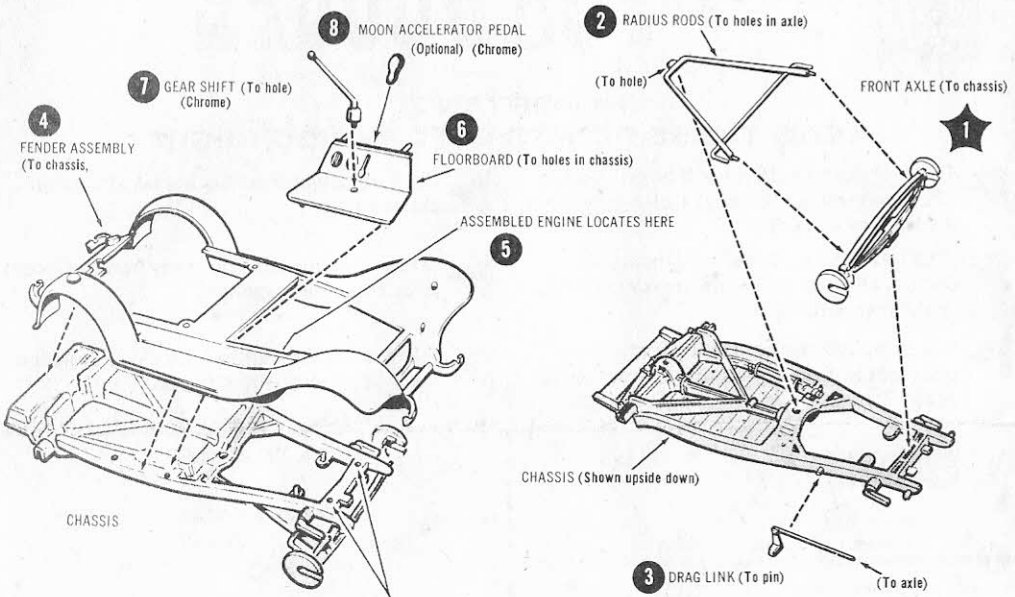

NOTE: Attach chassis to fenders locating pin on fenders to holes in chassis

5. BODY

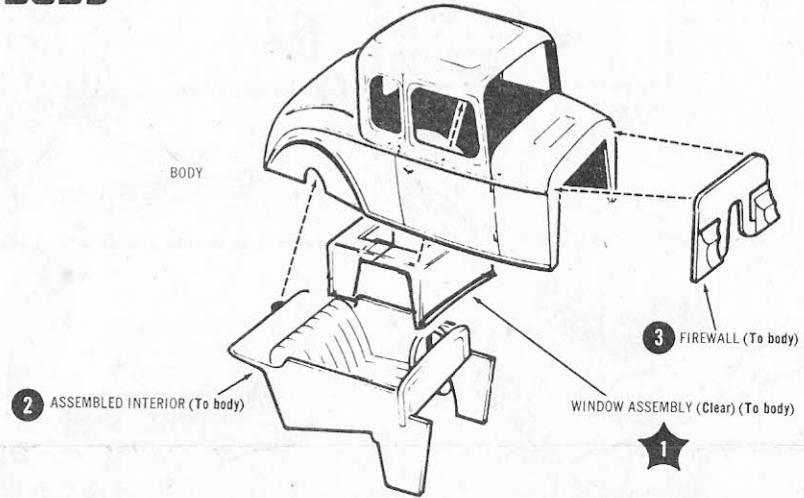

4. INTERIOR

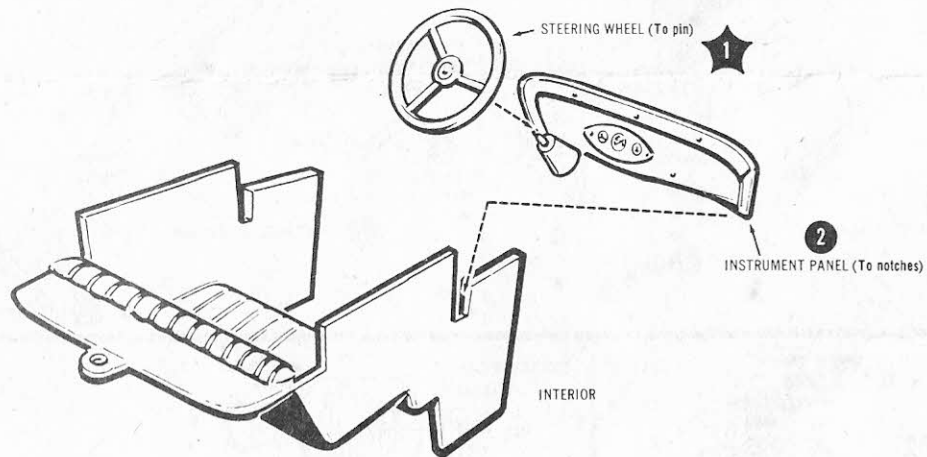

STOCK

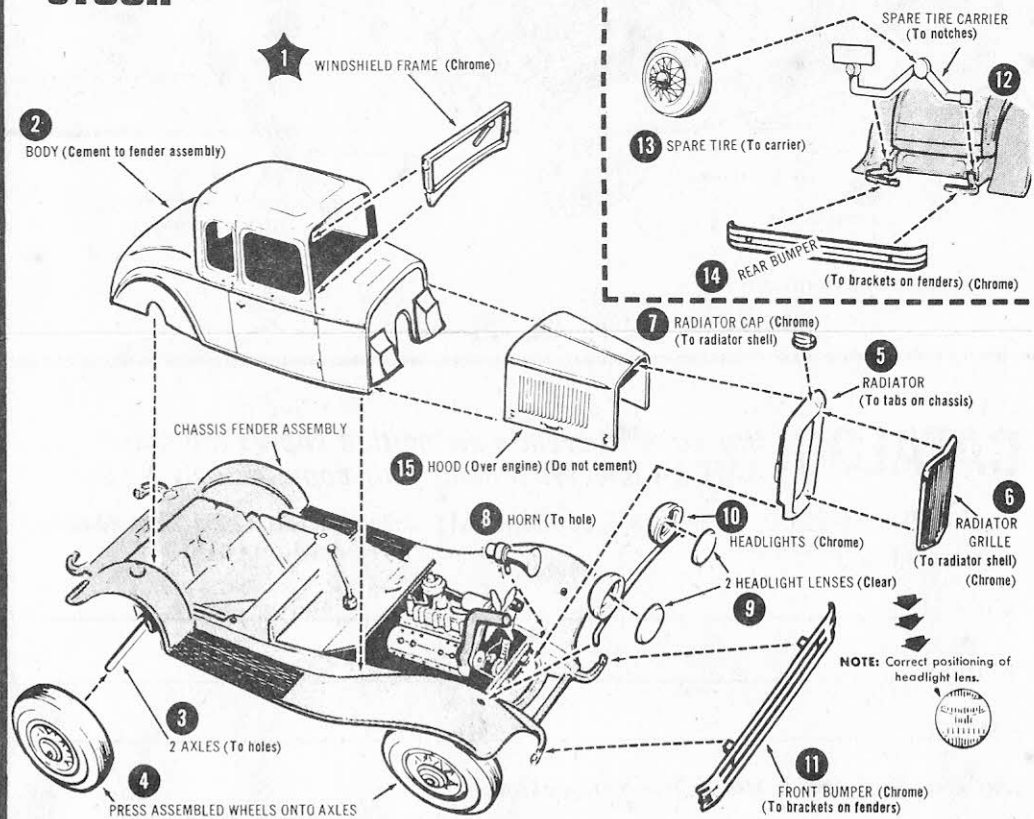

STREET

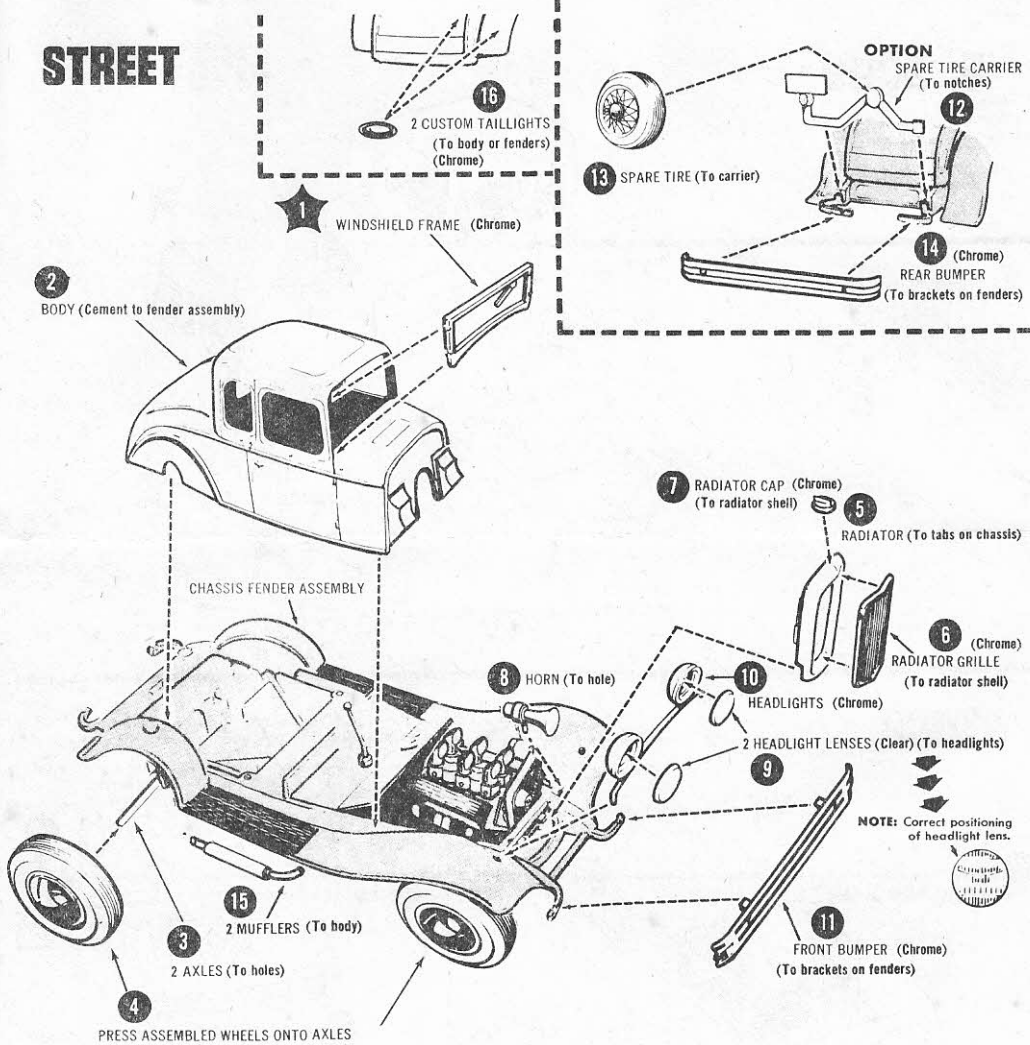

CATALOG! *Our colorful brand-new edition shows the entire AMT kit line. We'll send your copy for only \$1.00*

I am enclosing \$1.00 for my AMT catalog. AMT Corporation 1225 East Maple
(PLEASE PRINT) Troy, Mich. 48084

NAME _____

ADDRESS _____ CITY _____

STATE _____ ZIP CODE _____