

M88A1 RECOVERY TANK

M88A1戰車回收車

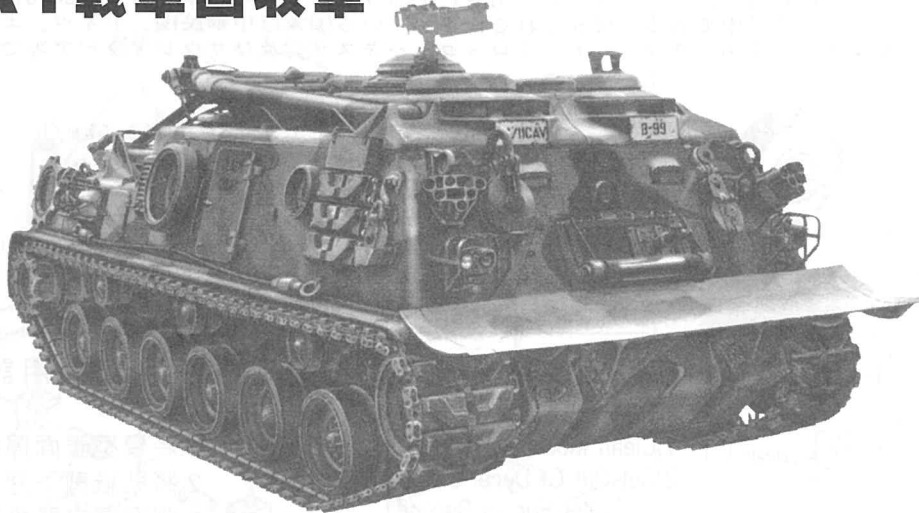

The M88 whole tracked armored recovery vehicle was designated by U.S. Army to be the standard ARV after the M-74 (with M4A3's hull). Since first production in 1960 till final vehicle were completed in 1964, by which time 1075 had been built. Developing based on M48A2 MBT. The M-88 use as many components as possible of the M48 tank family and have been service during Vietnam war.

In 1975 M88 was fitted with AVDS-1790-2DR diesel engine made by TELEDYNE CONTINENTAL MOTORS to replace the old power unit. It increase output up to 750bhp. Over the M48A2. Then the new style was named as M88A1.

M88A1 ARV operated by four crews. At the front of the vehicle is a spade operation winch and A-type Boom which maximum capacity is up to 25 tons. The commander has a .50 machine-gun for AA defence. M88A1's Allowable Speed is about 26 mph. curising range get over 300 miles.

From Vietnam-war to today, 2470 for U.S.Army, 79 for U.S.M.C. M88A1 are in active service in many country including R.O.C; Germany, Egypt, Greece, Israel. Korea, Kawait, Jordan, Morocco, Pakistan & Saudi Arabia.

CHARACTERISTICS:

Length: 325 inches
Width: 135 inches
Height: 123 inches
Weight: 56 tons

Top Speed: 27 mph; 18 mph with towed load
Cruising Range: 30 miles
Boom Capacity: 25 tons

M88全履帶裝甲救濟車是美國陸軍繼M74型救濟車(M4A3底盤)所開發的救濟車種,於1960年正式上線生產後至1964年已生產1075輛 M88是以M48A2戰車為基礎所發展,許多零件能和M48系列戰車共用,爾後M88也被使用於越南戰場。

BYM公司於1975年將原來M88的發動機換裝為大陸汽車公司(TELEDYNE CONTINENTAL MOTORS)之AVDS-1790-2DR型柴油發電機,將馬力提昇超過原來M48A2戰車的輸出馬力,並正式命名為M88A1。

M88A1救濟車搭配4位乘員,車前土鏟及絞盤加上能吊起重量25噸的A字型吊臂,車上並配有一挺50機槍 M88A1最快巡航速度為26英里,最大作業範圍300英里。

M88A1從越南戰爭結束起使用至今,除美國陸軍擁有2470輛及陸戰隊的79輛之外,也在其他國家服役中;目前正在使用的國家有:中華民國.德國.埃及.希臘.以色列.約旦.南韓.科威特.摩洛哥.巴基斯坦.及沙烏地阿拉伯。

性能諸元:

全長: 8.25公尺
全寬: 3.42公尺
高度: 3.12公尺
重量: 56公噸

最高時速: 43.5公里
拖曳時速: 29公里
巡航距離: 482公里
吊桿可吊重: 25公噸

M-88 フルーキャタピラ戦車回収車は、アメリカ陸軍がM74型回収車 (M4A4シャシ)に続いて開発されたものである。1960年からオンライン生産し、1964年に至るまでに、1075台を生産した。M-88はM48A2戦車をベースにして、延長開発されたもので、部品としてはM-48シリーズ戦車とは共通性がある。後にベトナム戦争にも使われている。

BMY社は、1975年にM-88のエンジンをTELEDYNE CONTINENTAL MOTORSのAVDS-1790-2DR型の重油エンジンに切り換え、馬力を向上させ、元のM-48A2戦車の出力馬力を越え、M-88A1と名付けた。

M-88A1回収車は、4名の乗員を搭載でき、並びに車前にシャベル、キャブスタンと最大起重25トンのA字型ハンガが装備されている。尚、車上にはさらに一機の50MM機関銃を装備されている。M-88A1の最高巡航速度は26マイルで、最大工作範囲は300マイルである。

M-88A1はベトナム戦争が終えてから、今にも使用されており、アメリカ陸軍が有する2470台と陸戦隊の79台を除いて、その他の国でも服役中である。現在これを使用している国家は中華民国、ドイツ、エジプト、ギリシャ、イスラエル、ヨルダン、韓国、クウェート、モロッコ、パキスタン及びサウジアラビア等である。

データ:

全長:8.25m

全幅:3.42m

全高:3.12m

重量:56t

最大速度:43.5km/h

牽引速度:29km/h

行動距離:482km

クレームの最大重量:25t

Illustration: 圖示説明



File Hole
將孔填平



No Agglutinate
不用黏合



Make 2 Sets
二組製作



Cut Off
切除



Optional
選擇使用



Apply Decal
貼上貼紙



Be Careful
注意



Open Hole
鑽孔加工

Method For Applying Decals:

1. Clean Model Surface With Wet Cloth.
2. Cut Out Of Decal Sheet And Dip Them In Water For 15 Seconds.
3. Place it on proper position on model.
4. Slide off base paper leaving decals On Model With Wet Finger Tip.
5. Move Decals To Exact Position, Push Out Excess Water Under Decal With Soft Cotton Cloth.
6. When Decals Get Dry Then Complete.

水貼紙使用説明:

1. 將模型表面擦乾淨
2. 將貼紙剪下泡入清水中約15秒
3. 將泡濕之貼紙取出置於欲貼處旁
4. 用指尖輕推貼紙表面使其滑出底紙
5. 將貼紙調整至適當位置並輕擦拭水份
6. 待其自然乾燥後即完成

Color list: 塗料表

Color	Brand	Gunze Sangyo			Humbrol	Revell	Life Color
		Hobby Color	Mr. Color	Mr. Color Spray			
Olive drab	橄欖綠	H-78	C-38	J-38	66	46	UA106
Steel	黑鐵	H-18	C-28	J-28	53	91	LC76
Tire black	輪胎黑	H-77	C-33+C-62		85	302	
Red	紅	H-3	C-3	J-3	19	31	LC56
Black	黑	H-2	C-2	J-2	21	07	LC52
Red brown	紅褐	H-47	C-41	J-44	160	383	
Silver	銀	H-8	C-8	J-8	11	90	LC74
Green FS34227	綠	H-27	C-44	J-44	101	360	
Bronze green RAL 6031	銅綠		TC-10		161	361	
Leather brown RAL 8027	皮革		TC-11		118	38	UA015
Tar black RAL 9021	瀝青		TC-12		33	08	LC02
Yellow FS33531	黃	H-313	C-313			88	

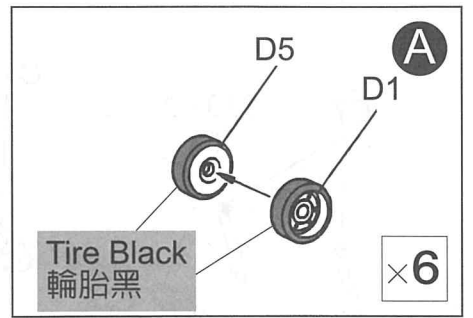
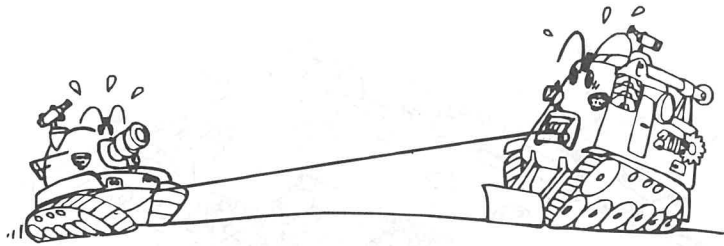

1

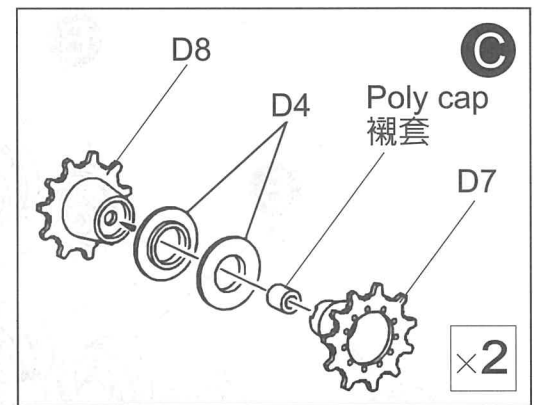
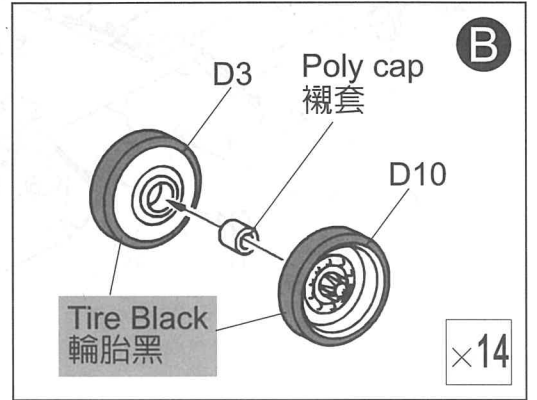
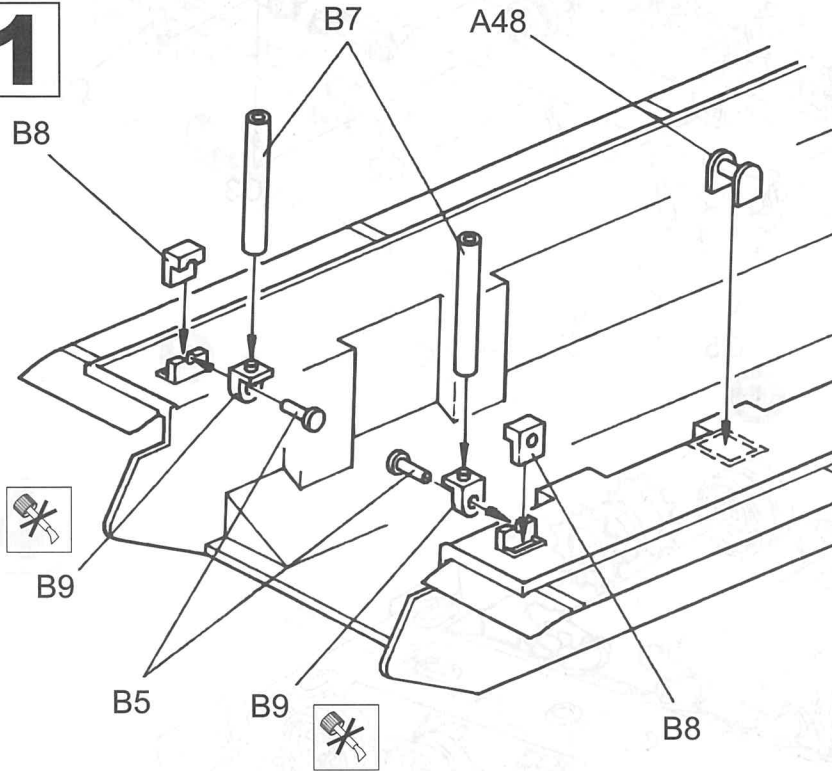

2

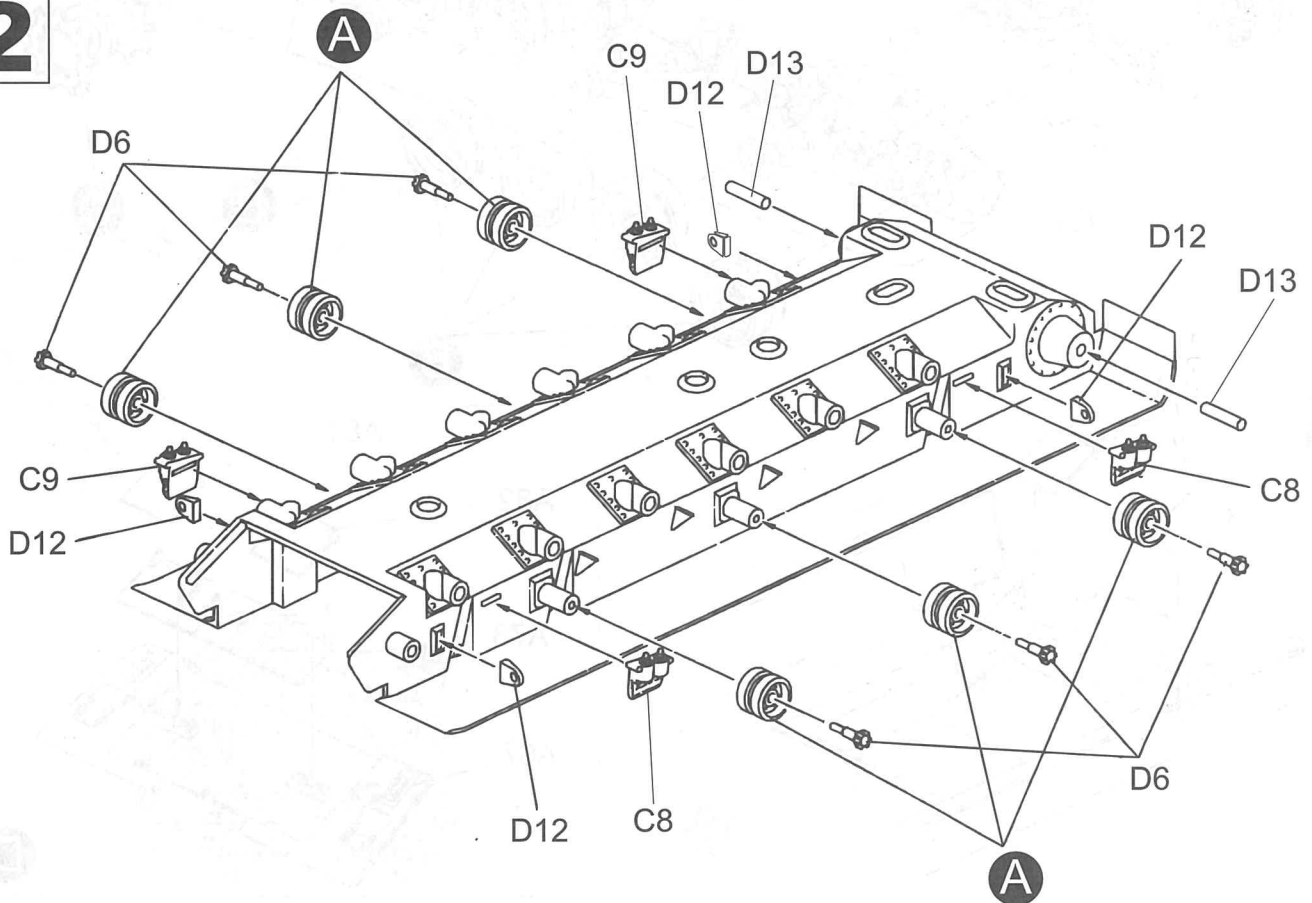

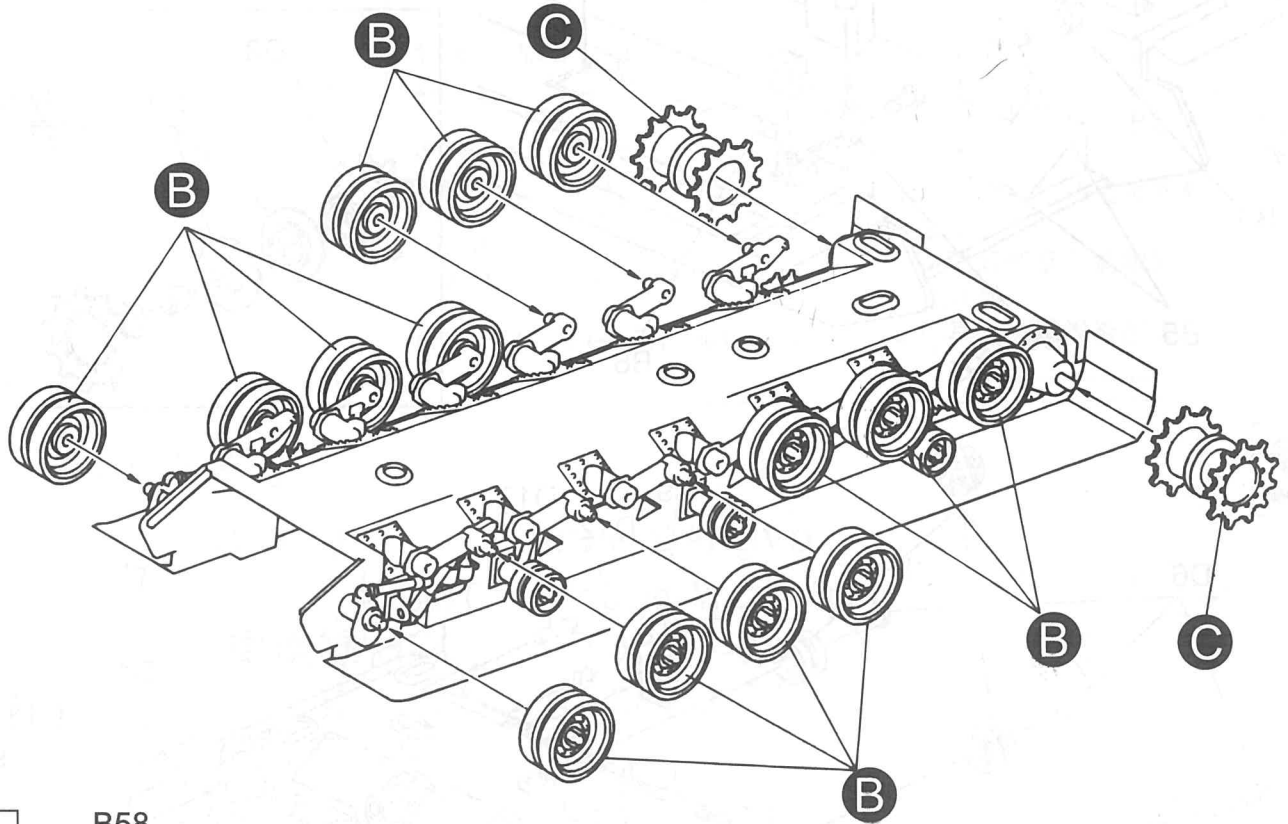
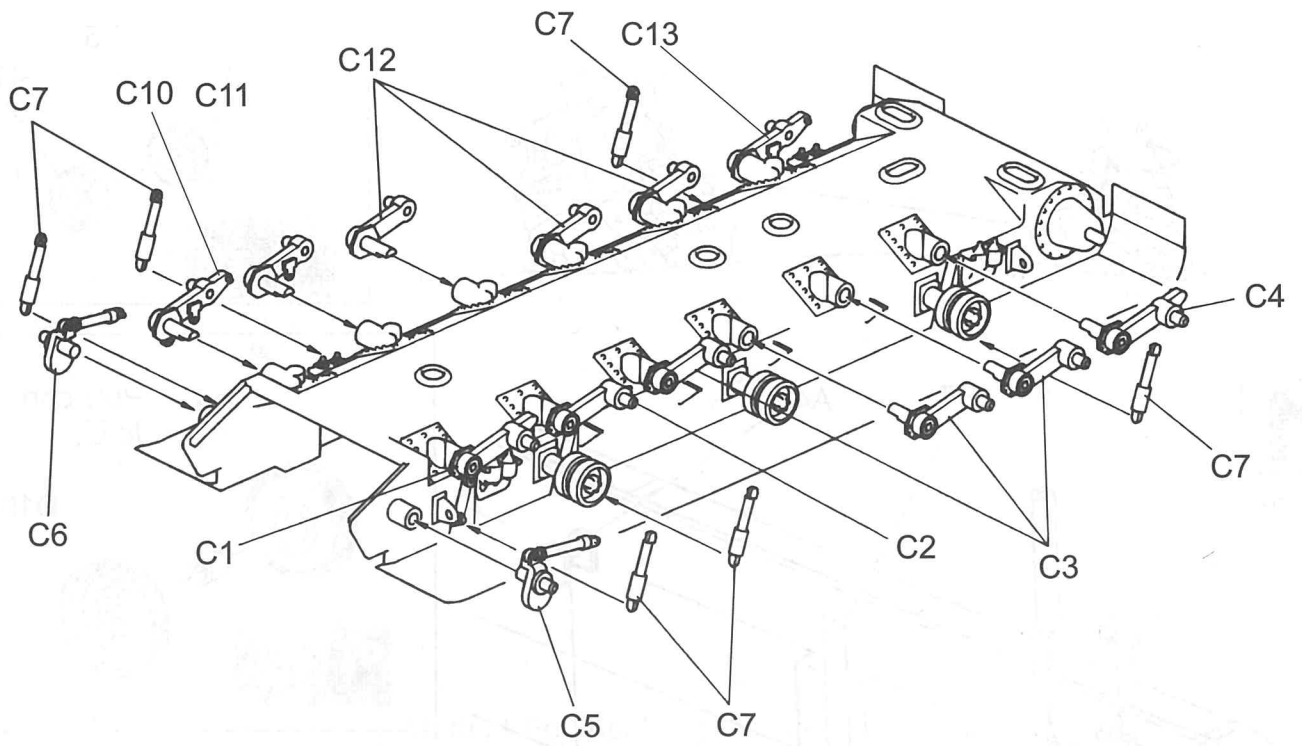

3

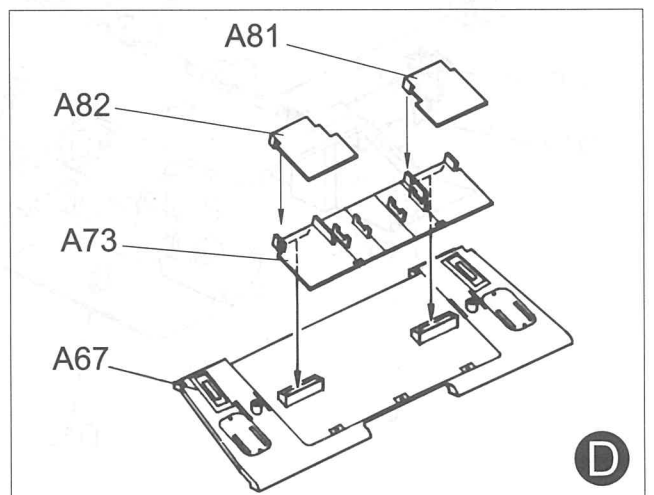
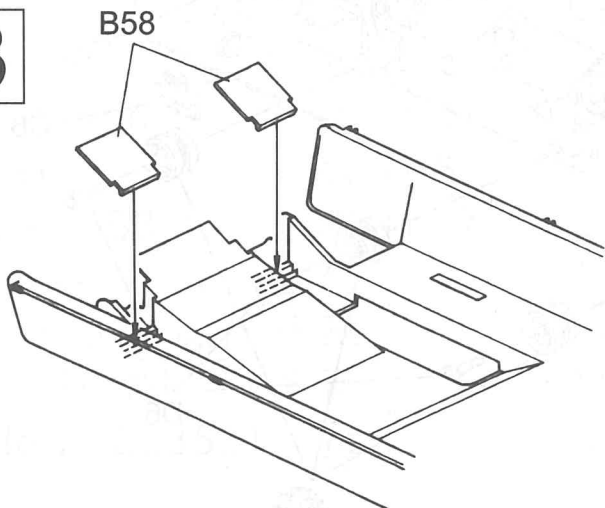

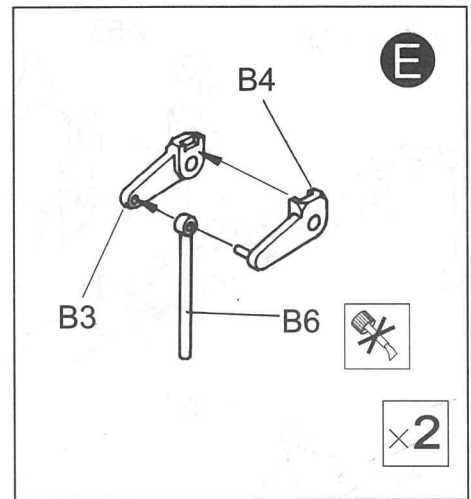
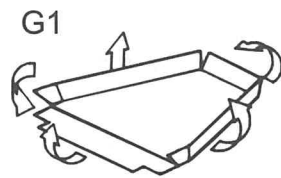
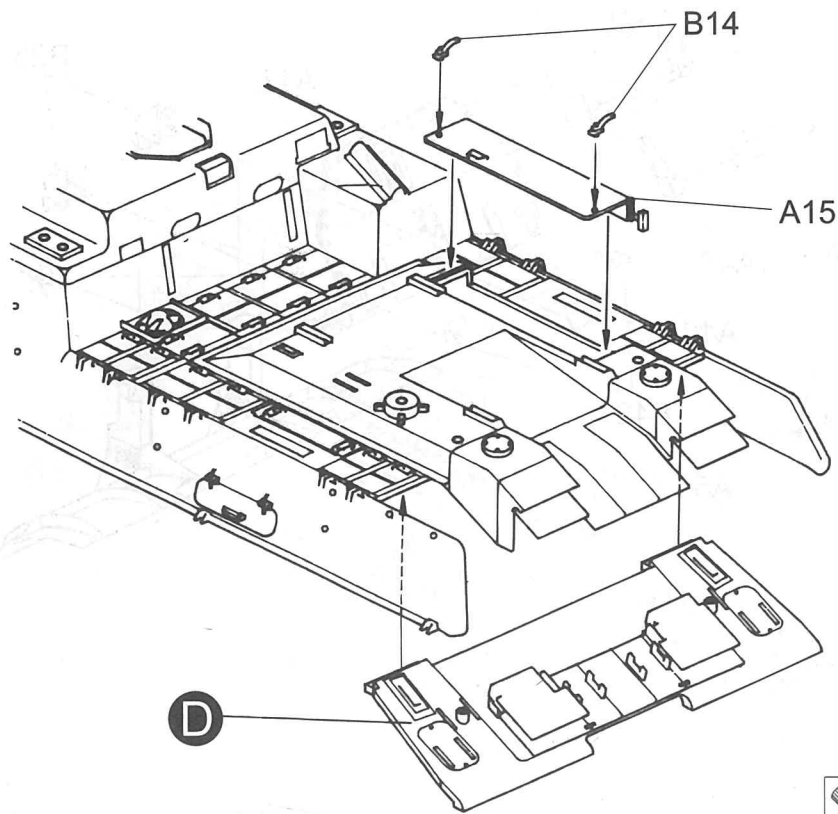

4

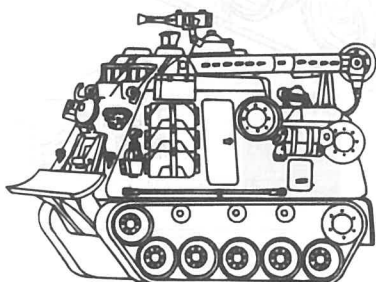
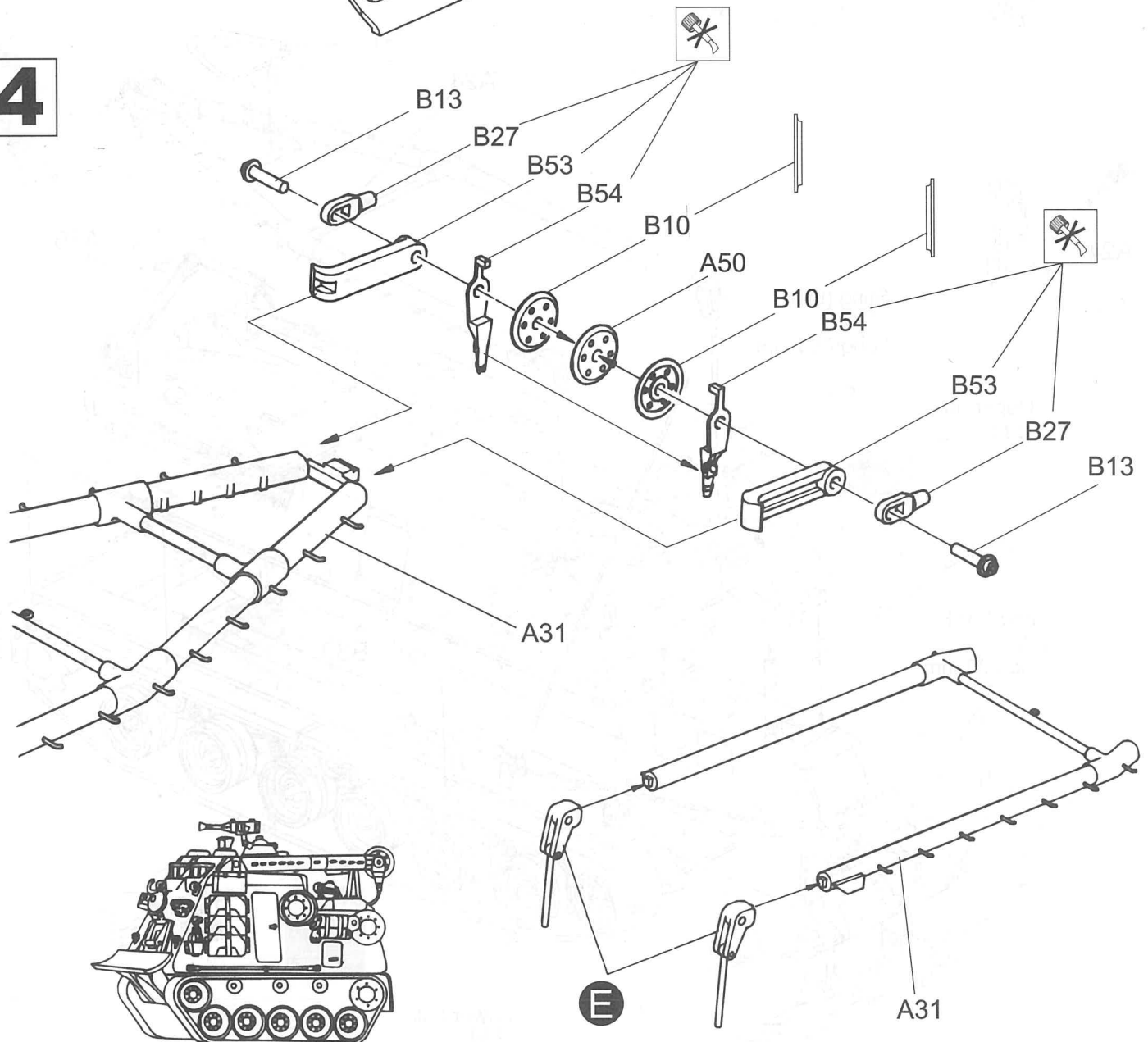

5

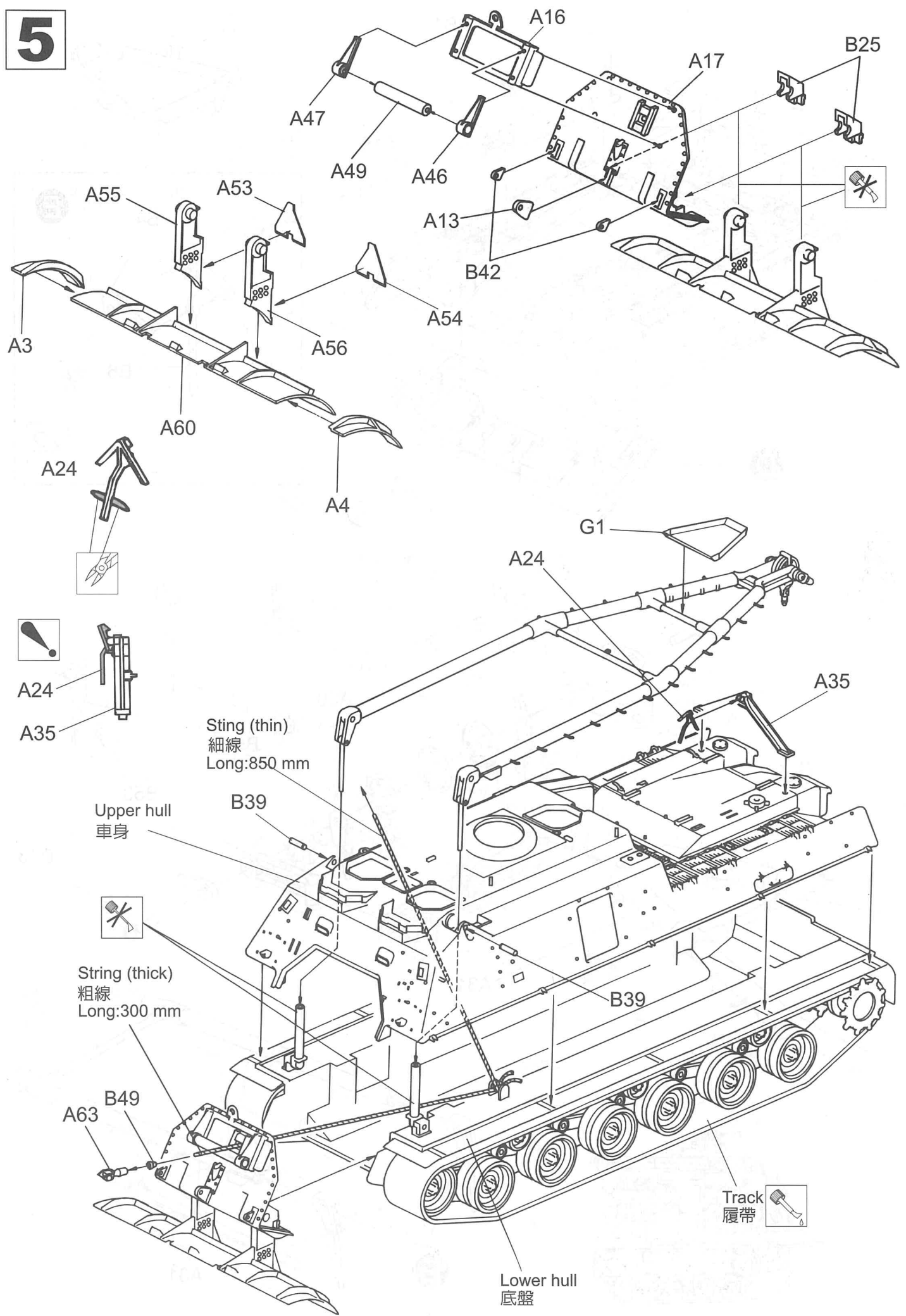

6

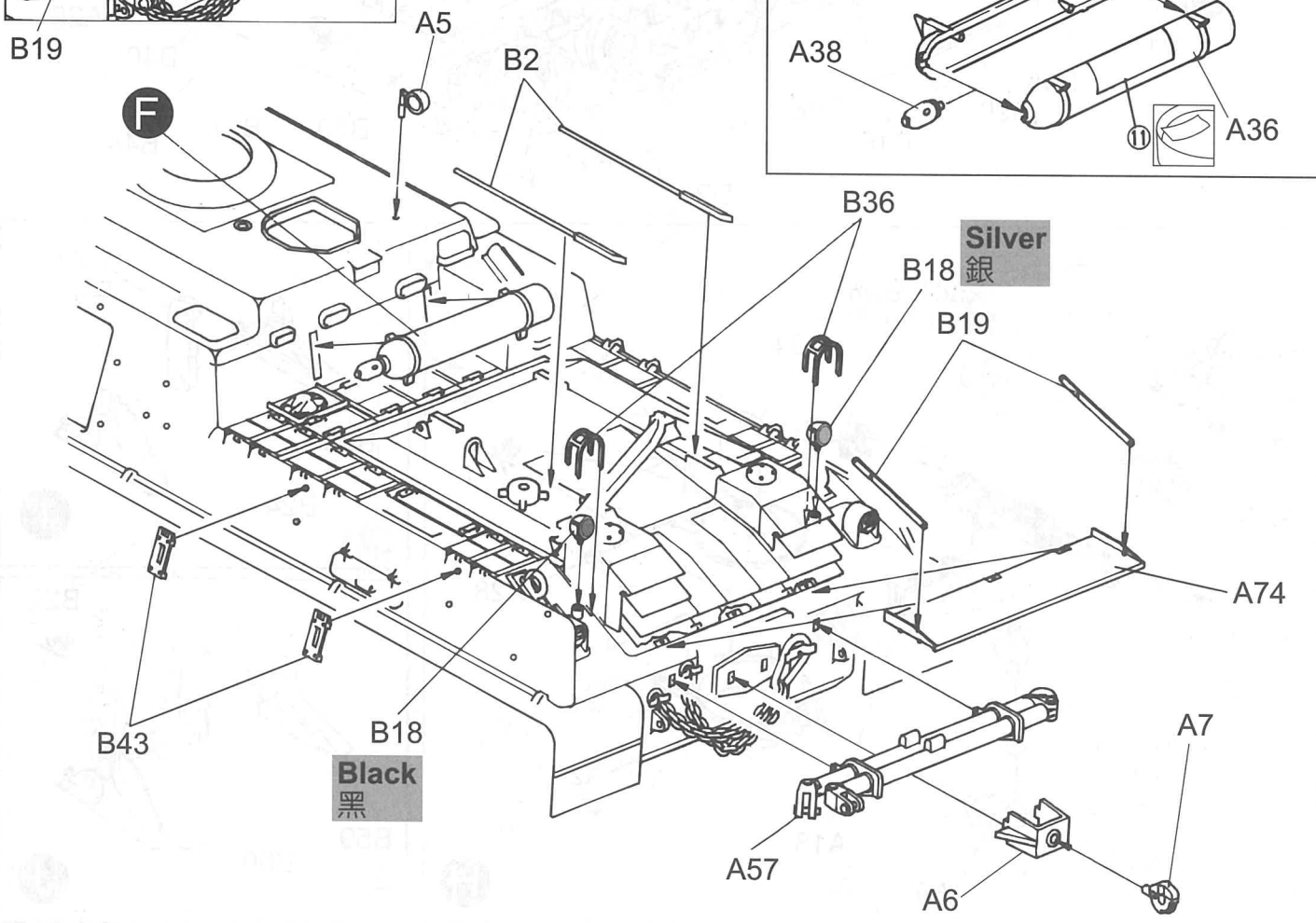
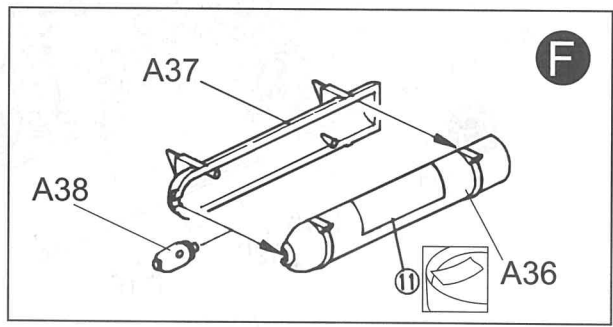
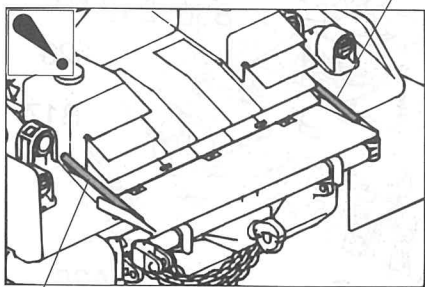
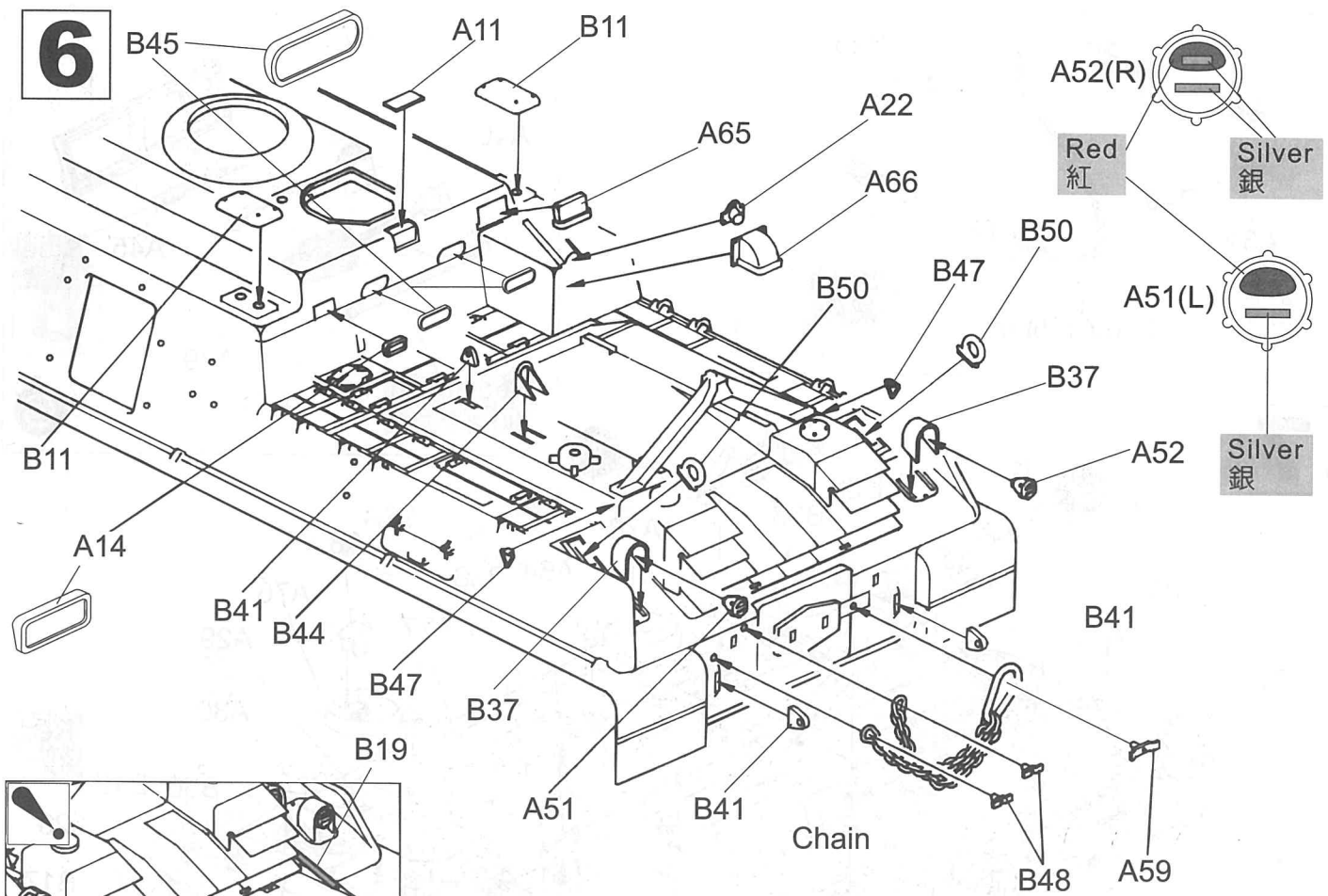

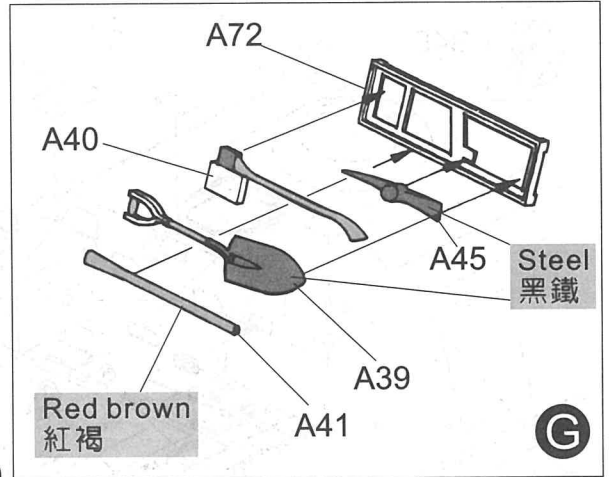
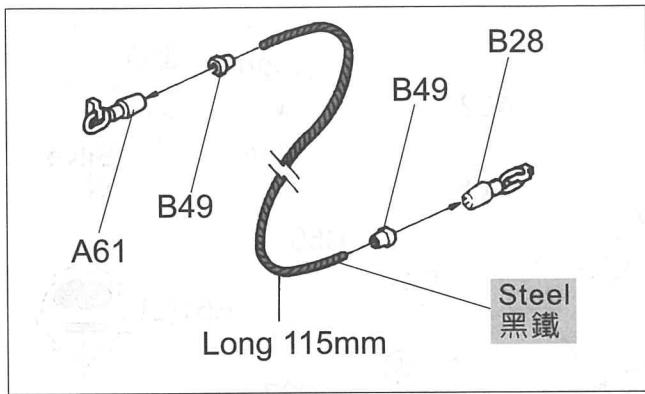

7

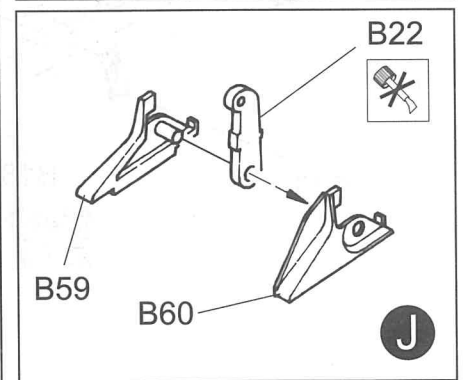
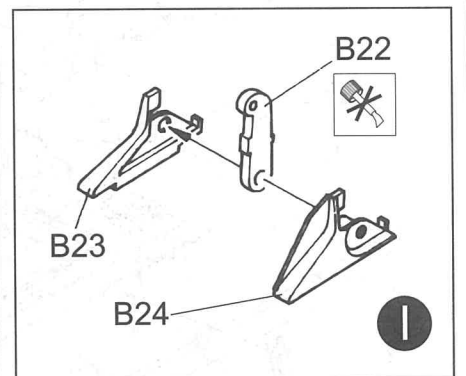
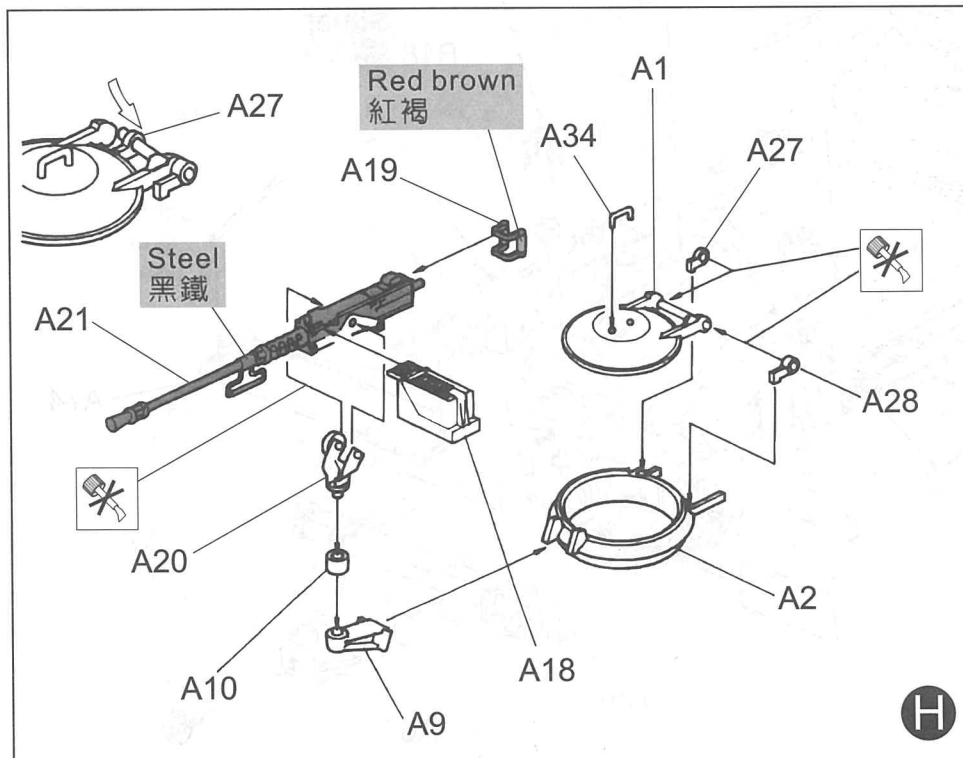
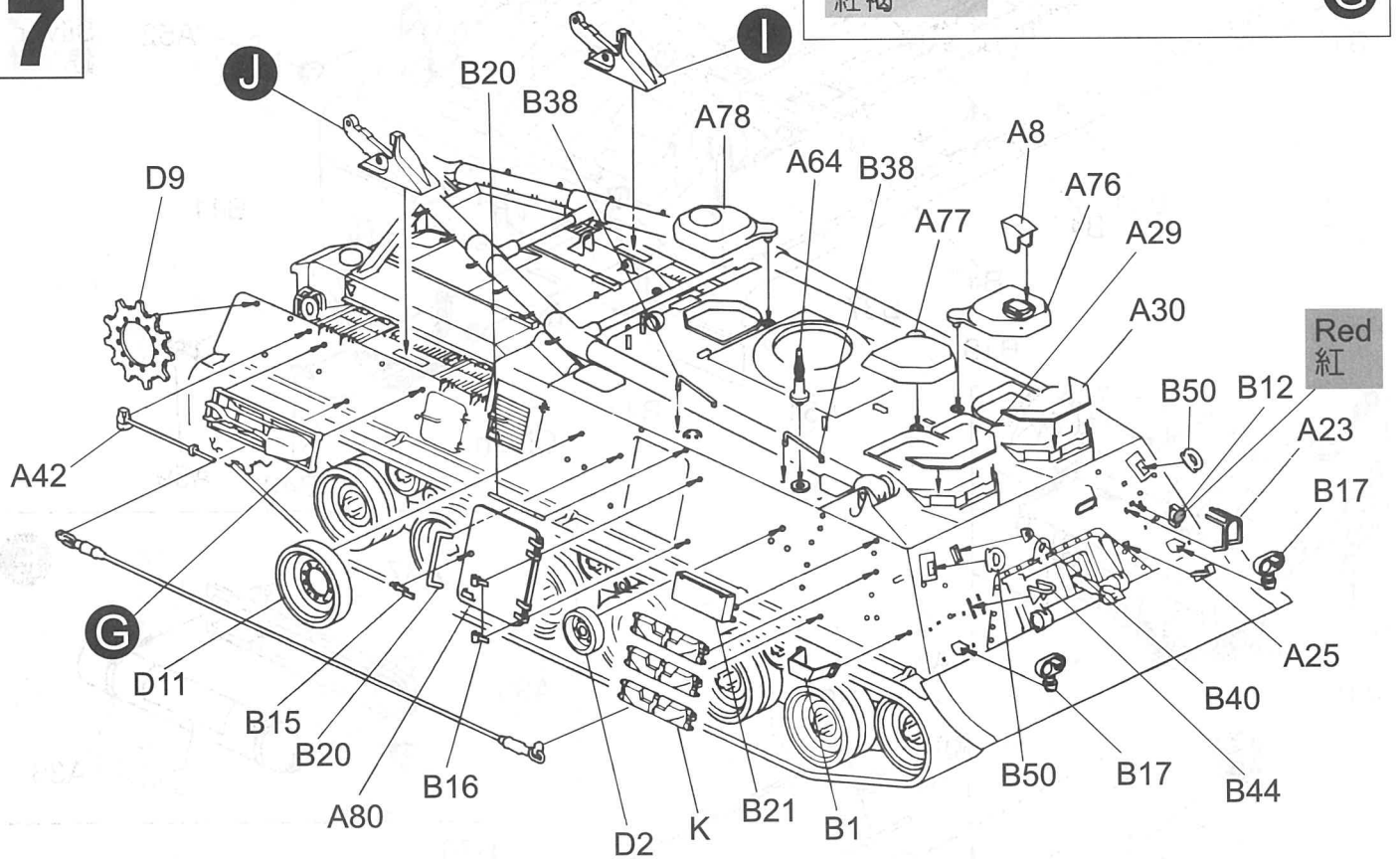

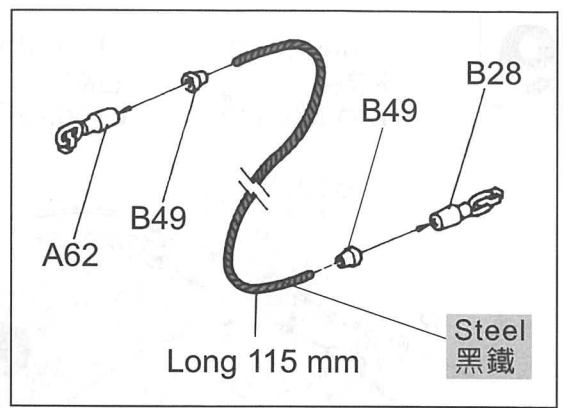
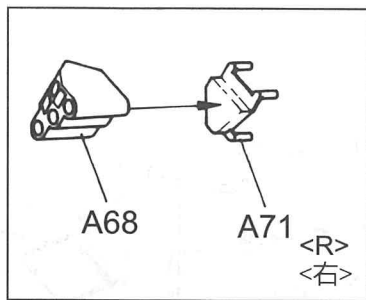
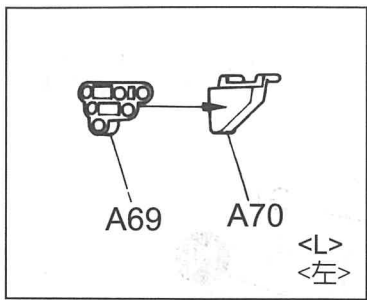

8

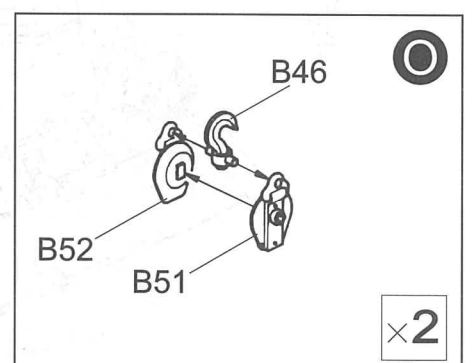
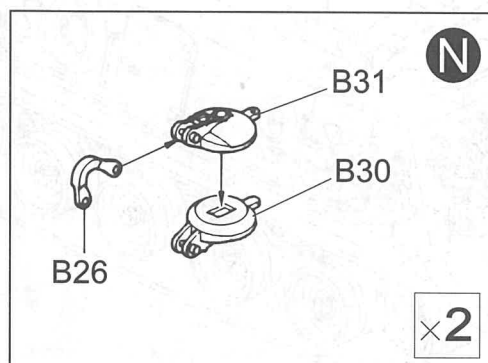
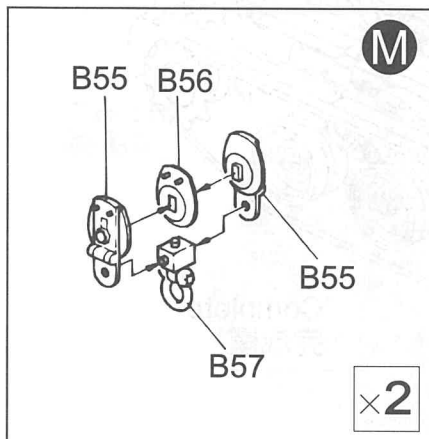
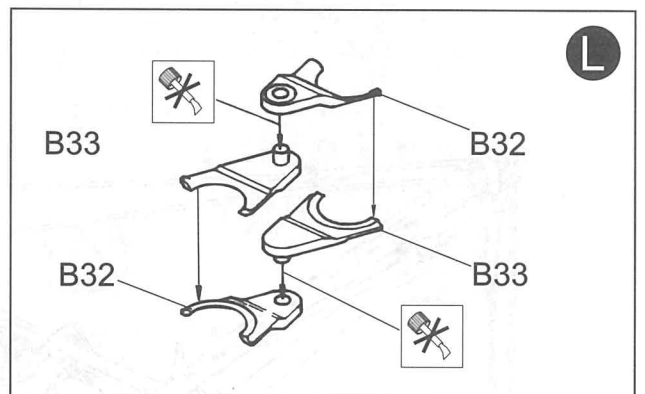
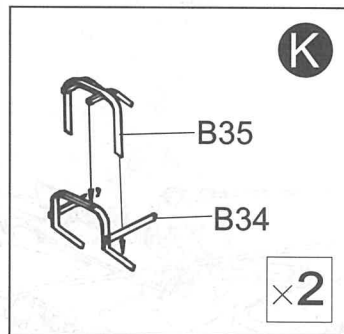
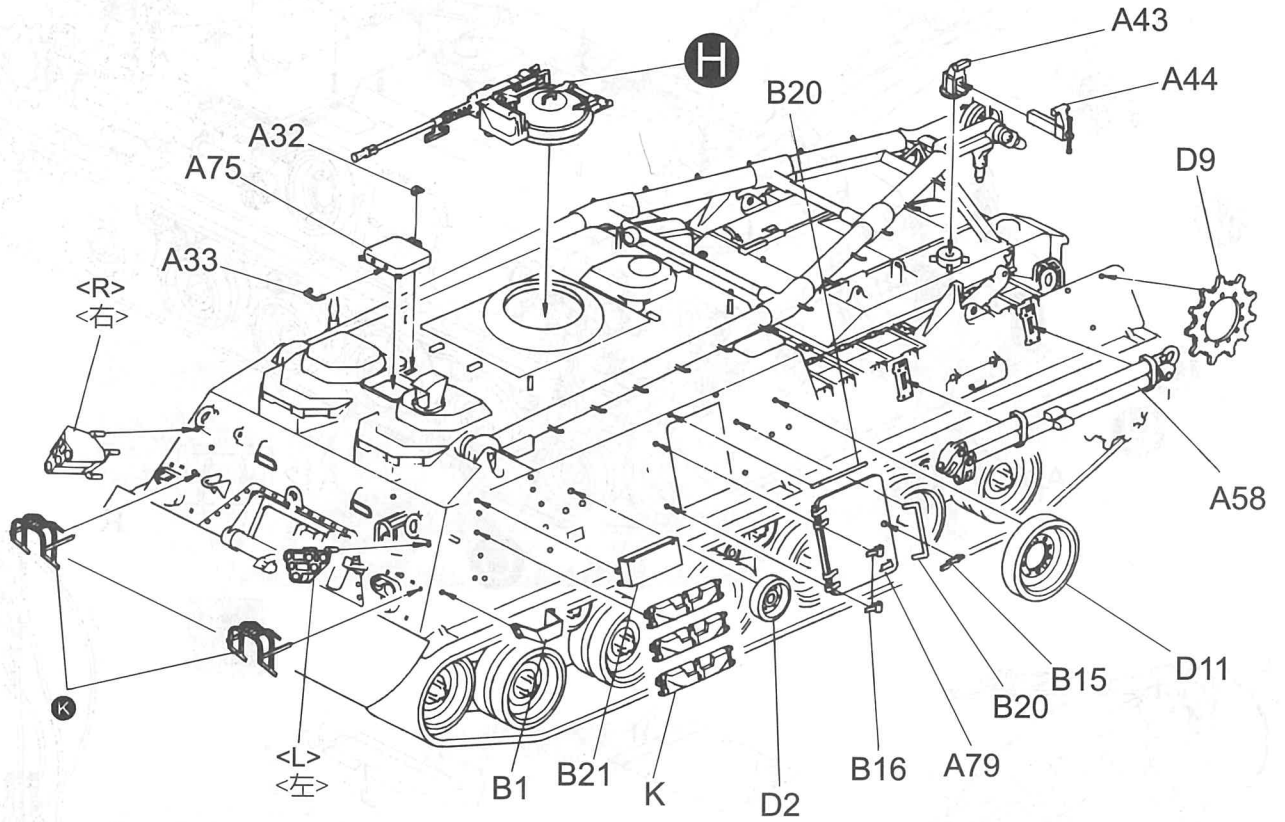

9

String (thick)
粗線
Long:70mm

String (thick)
粗線
Long:420mm

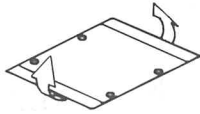
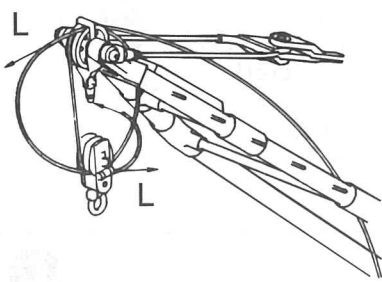
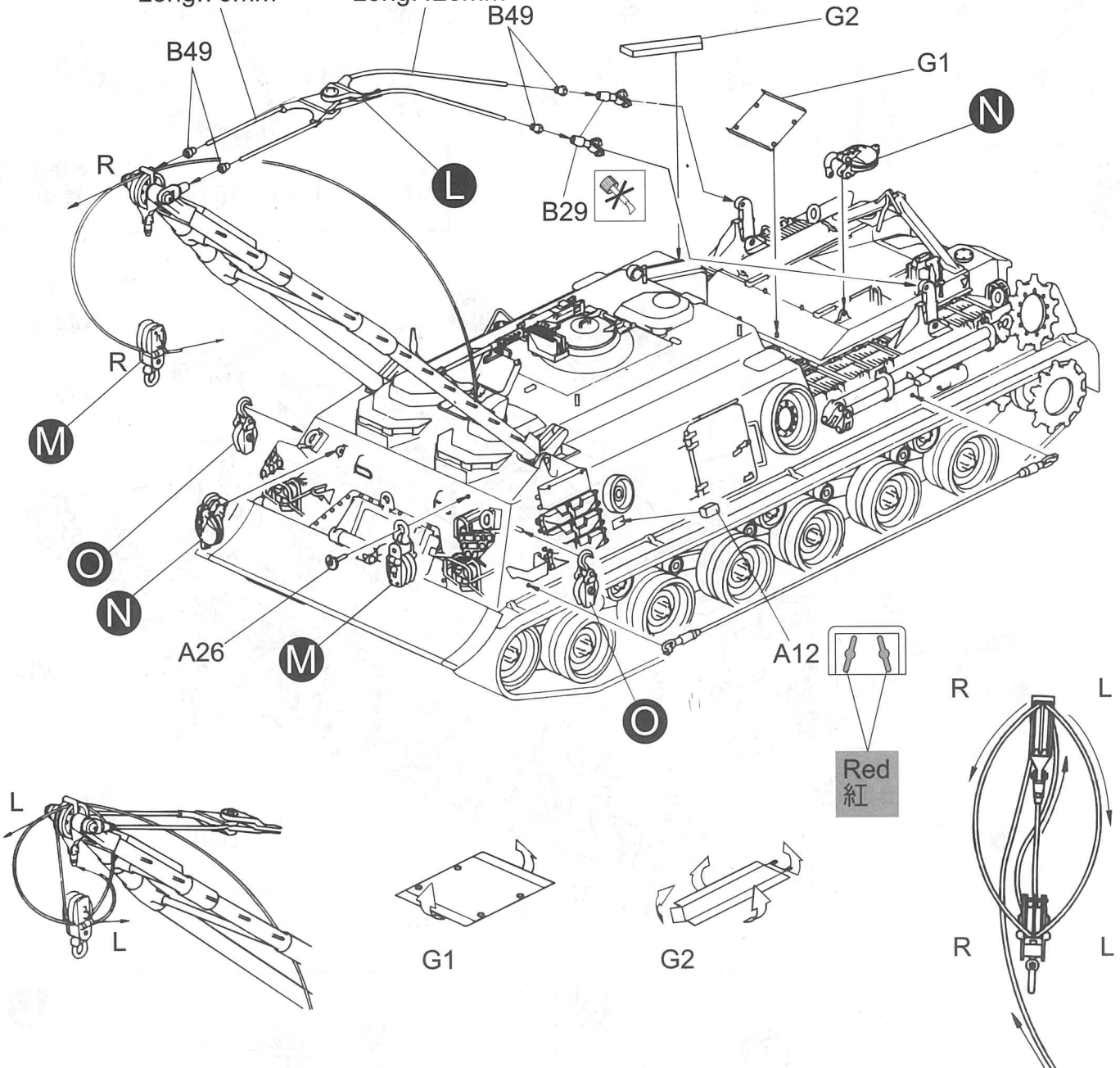

G1

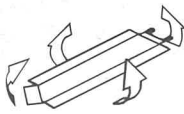

G2

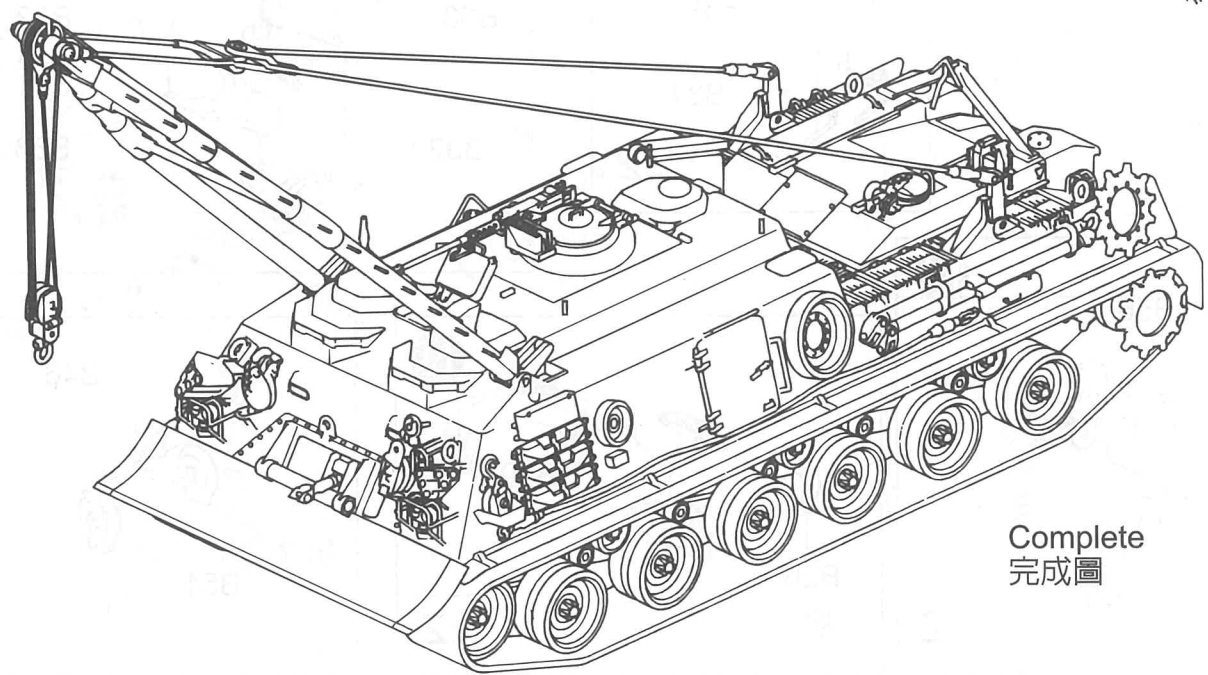
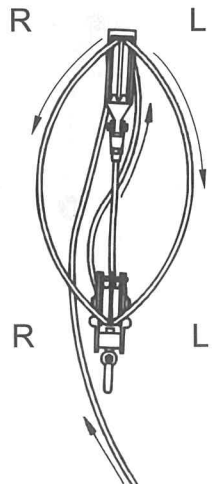

Complete
完成圖

1 R.O.C. army body:
中華民國陸軍塗裝:

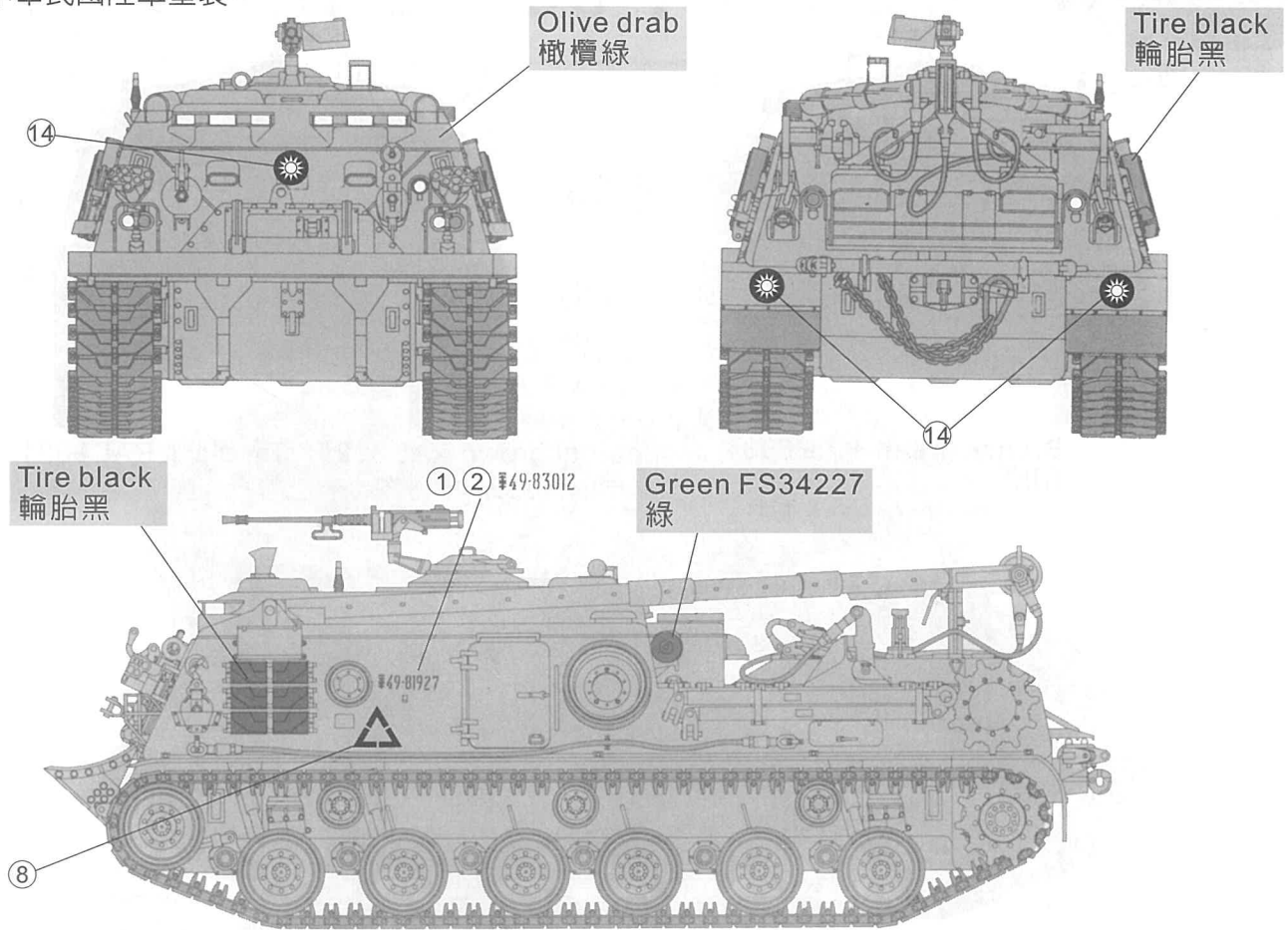

2 German army body:
德國陸軍塗裝:

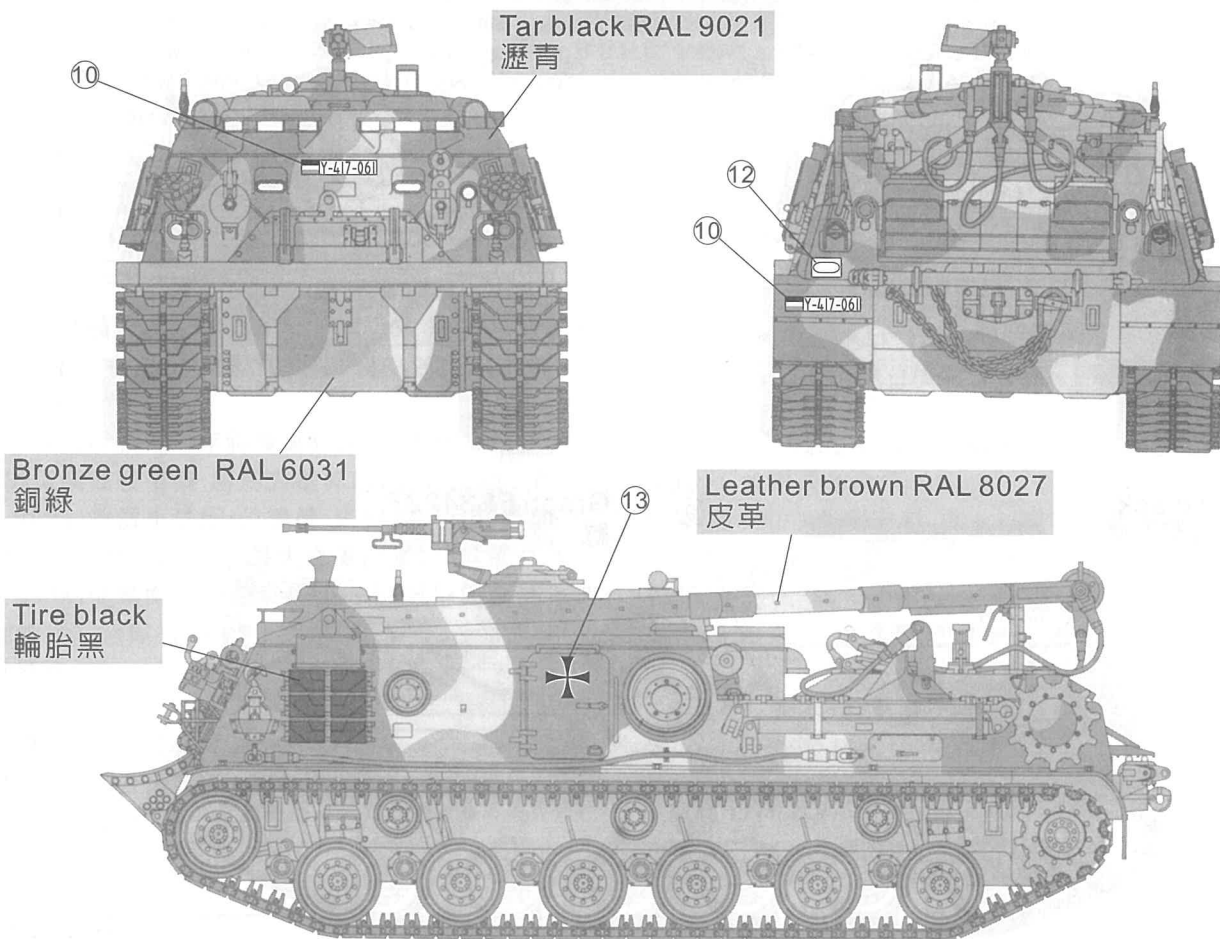

③ US army body:
美國陸軍塗裝:

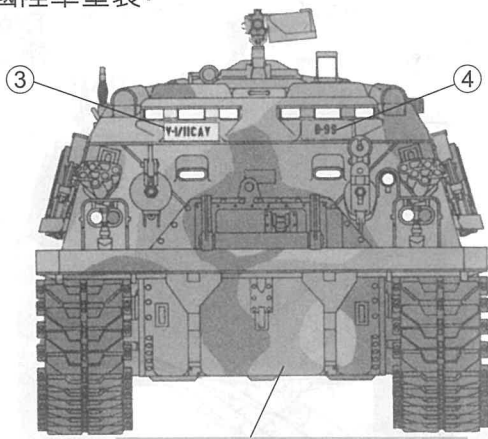

Bronze green RAL 6031
銅綠

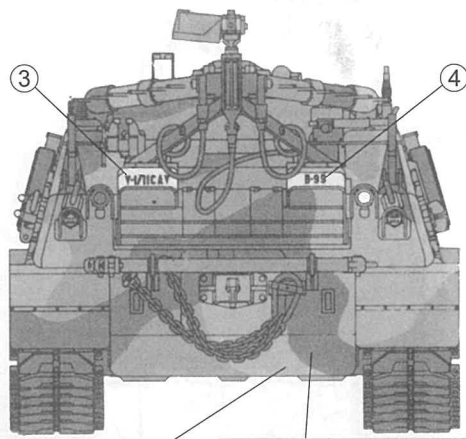

Leather brown RAL 8027
皮革

Tar black RAL 9021
瀝青

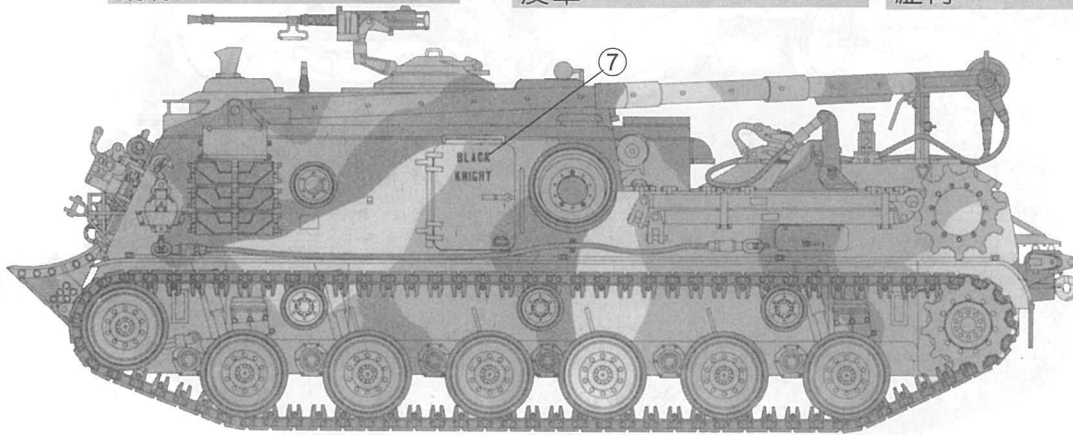

④ USMC body:
美國海軍陸戰隊塗裝:

Yellow FS 33531
黃

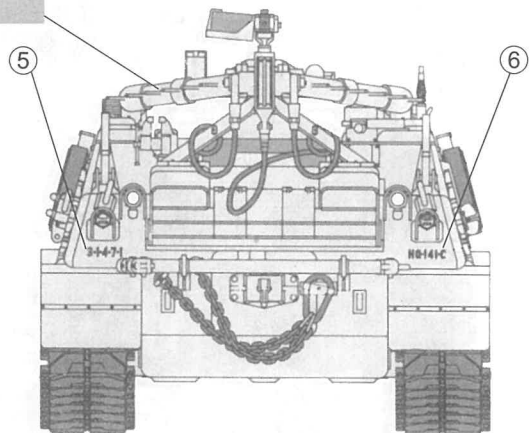
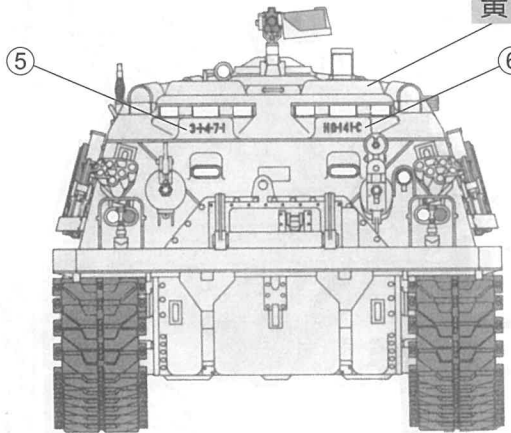

Tire black
輪胎黑

Green FS34227
綠

