

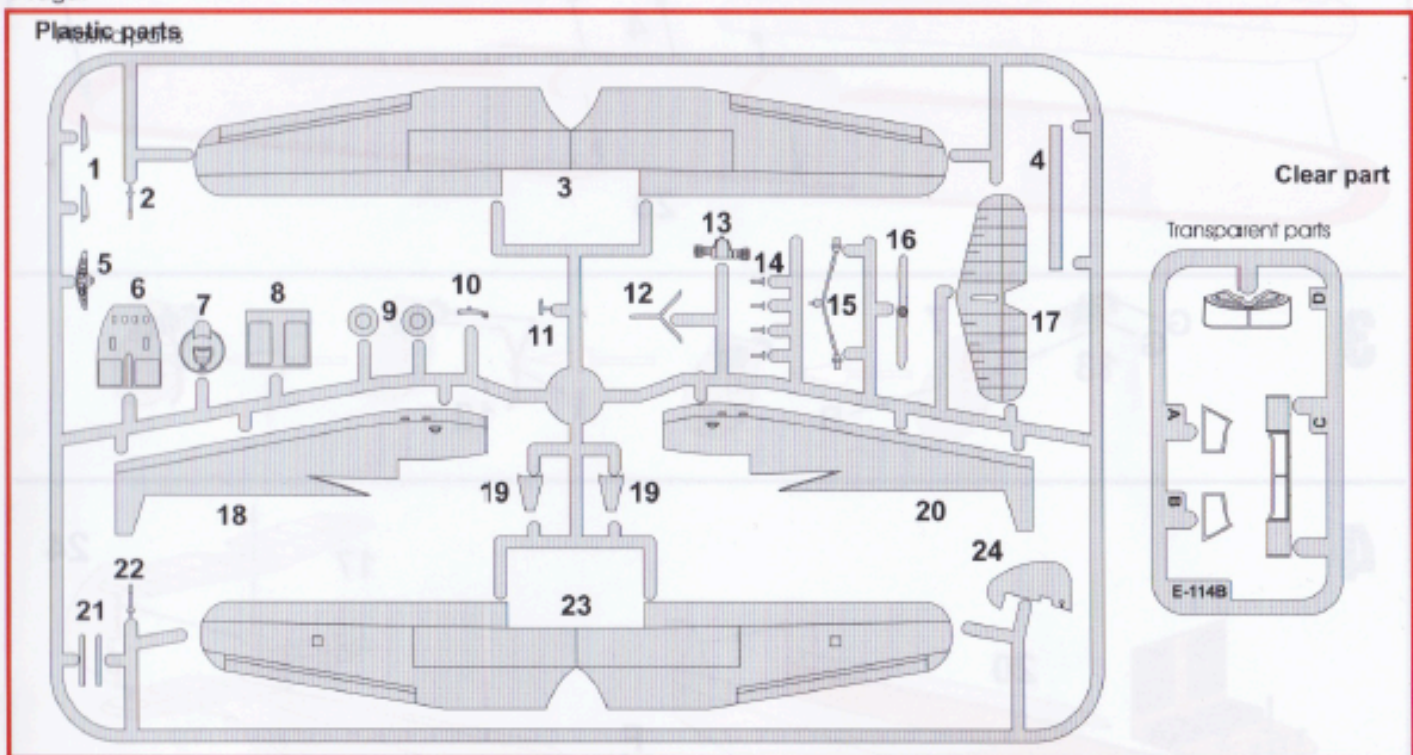

# HILLSON PRAGA E-114 „AIR BABY”

Praga E-114 Air Baby poprvé vzlétla v roce 1934 a ihned vzbudila velký zájem. Následně se dostavily i první sportovní úspěchy a o sériová letadla byl zájem nejen v našich aeroklubech ale i v zahraničí. Postupně letadla Air Baby odebrali zákazníci z Francie, Iránu, Rumunska a Velké Británie. Tam byl typ Praga E-114 dokonce licenčně vyráběn pod obchodním názvem Hillson Praga u firmy F. Hills & Sons v Manchesteru.

Praga E-114 Air Baby was flying in 1934 for the first time with high interest among pilots and public. Air Baby later achieved various sport successes and company got the orders from abroad. Air Baby were exported to France, Iran, Rumania and Great Britain. Praga E-114 were built under license by the company F. Hills & Sons, Manchester and designed Hillson Praga.



Symbols/Symboly			
Drill hole Vyvrtat	Cyanoacrylate Vlefinové lepidlo	Remove Odstranit	Red ace Zbrousit
Make new Vyrobit	Option Volba	Bend Ohnout	Purty Tmel

	Colour name	Humbrol		Colour name	Humbrol
A	Black	H33	F	Natural Wood	H110
B	Aluminium	H56	G	Gunmetal	H53
C	Interior Green	H76	H	Tyre	H85
D	Brown	H186	I	Rust	H113
E	Linen	H74	J	Red Brown	H100

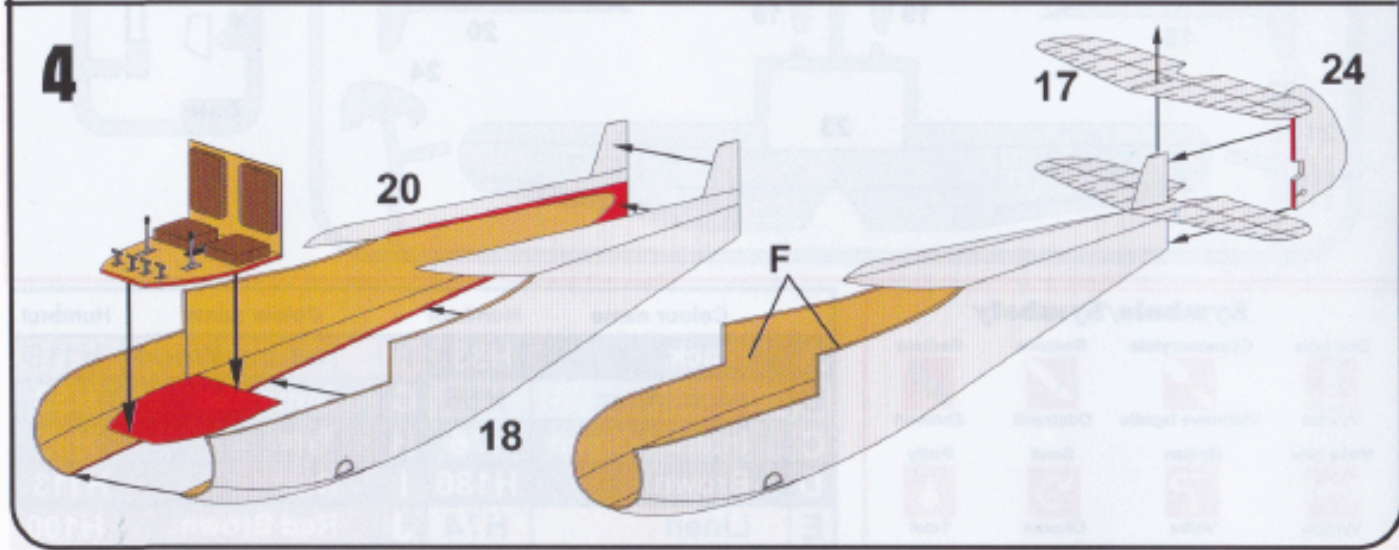
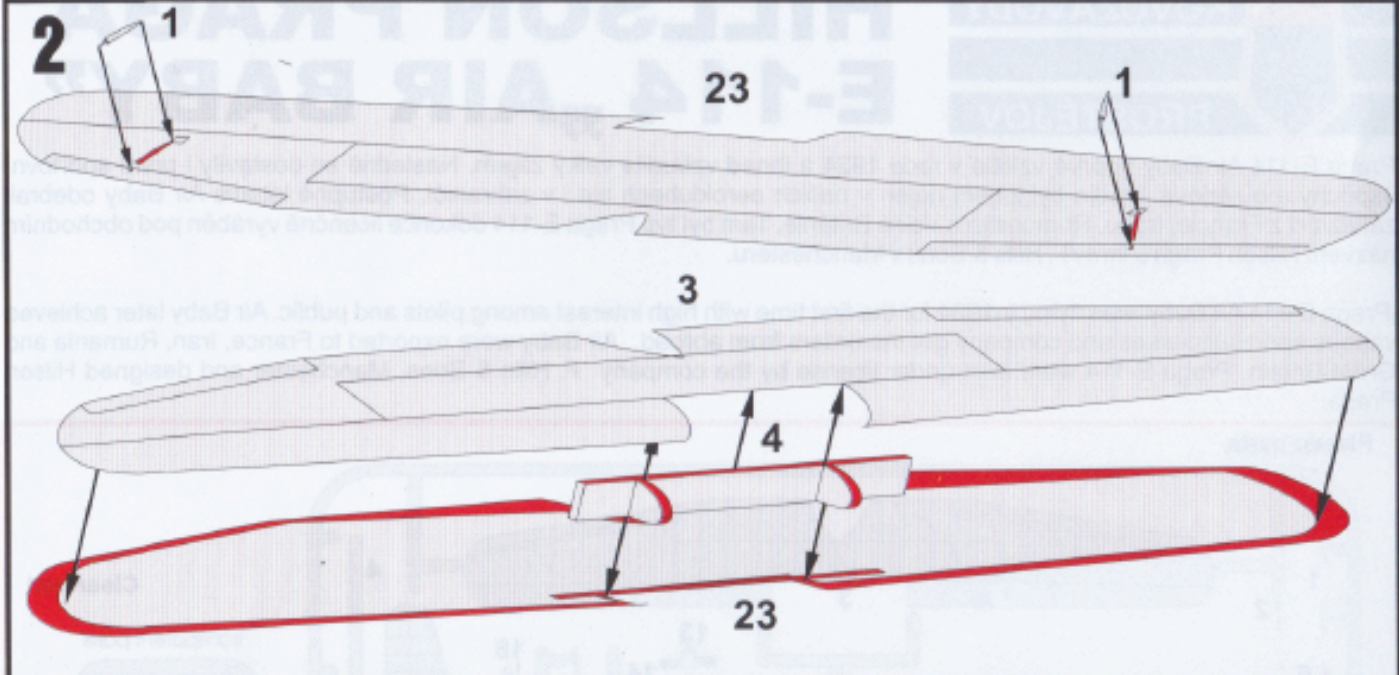
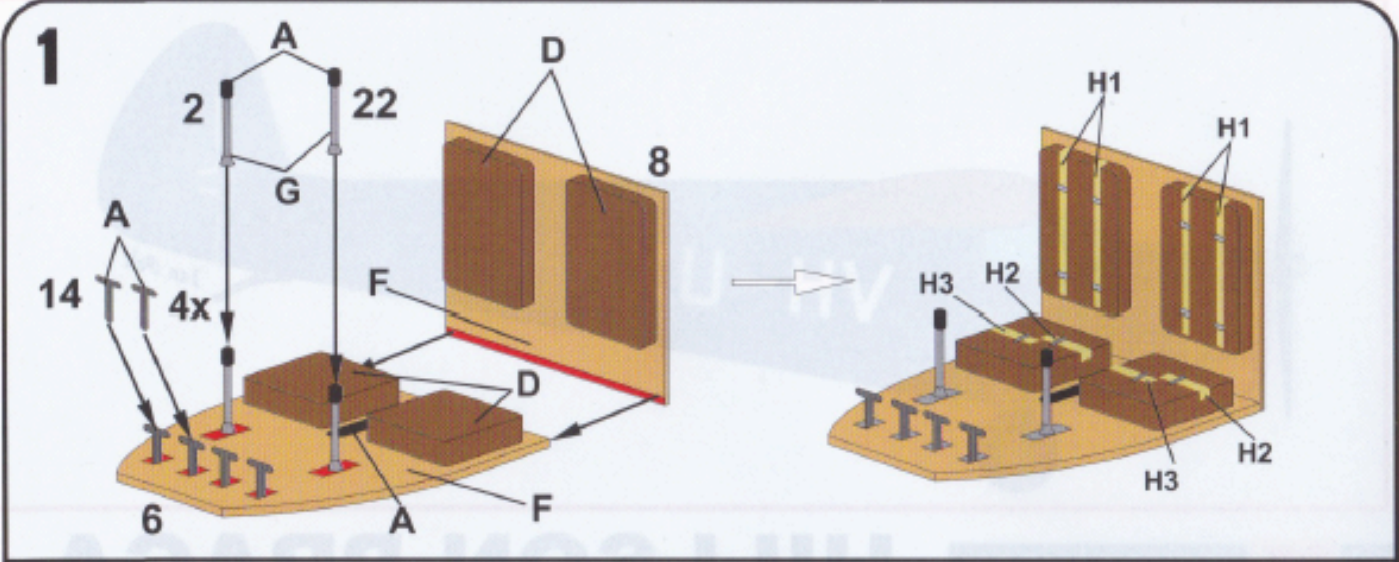

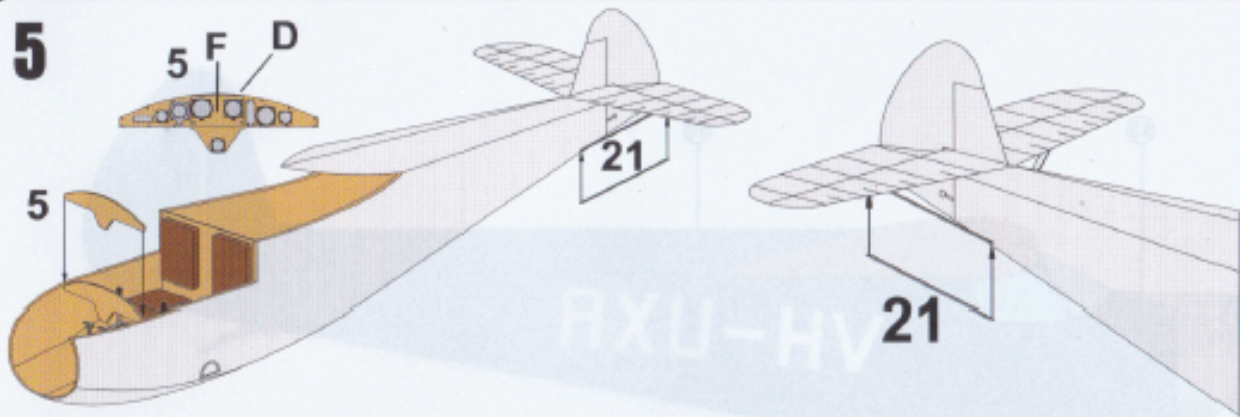
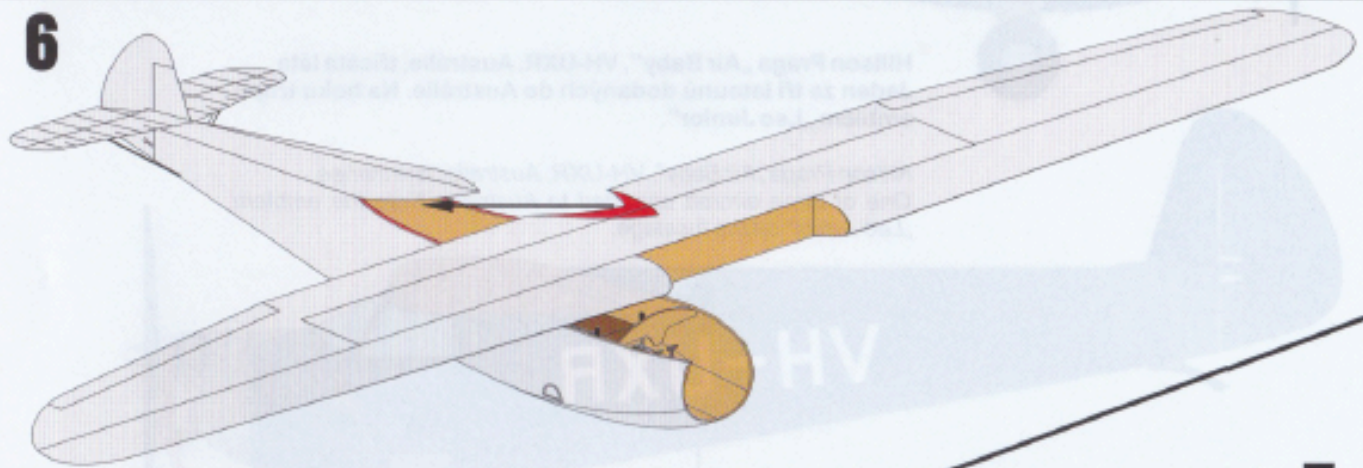
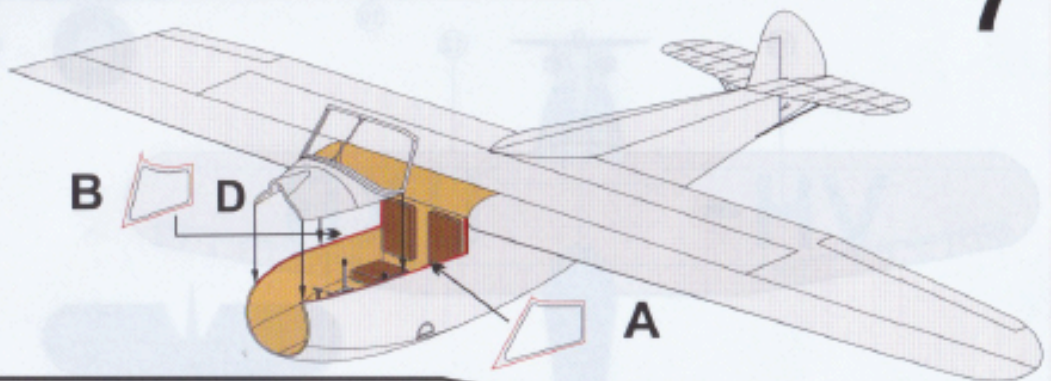
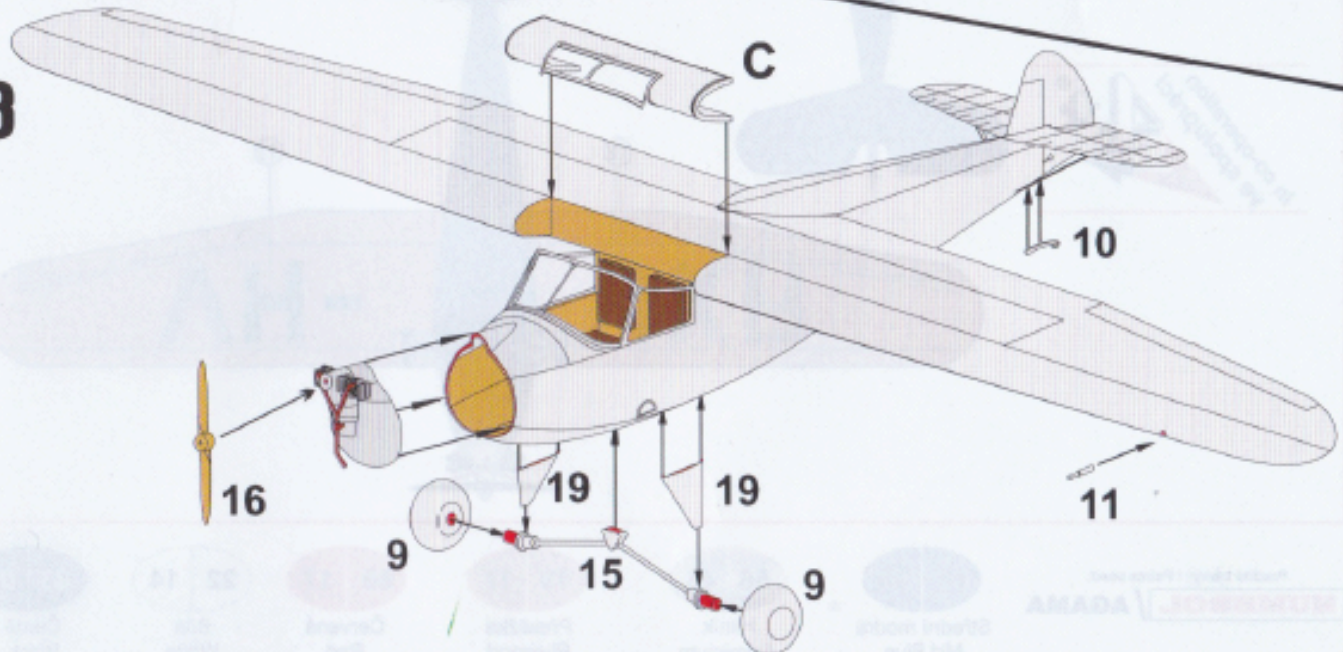
**5****6****7****8**

3



Hillson Praga „Air Baby”, VH-UXR, Austrálie, třicátá léta  
 Jeden ze tří letounů dodaných do Austrálie. Na boku trupu  
 emblém „Leo Junior”.

Hillson Praga „Air Baby”, VH-UXR, Australia, late thirties.  
 One of three aircraft exported to Australia. Note the emblem  
 „Leo Junior” on the fuselage.

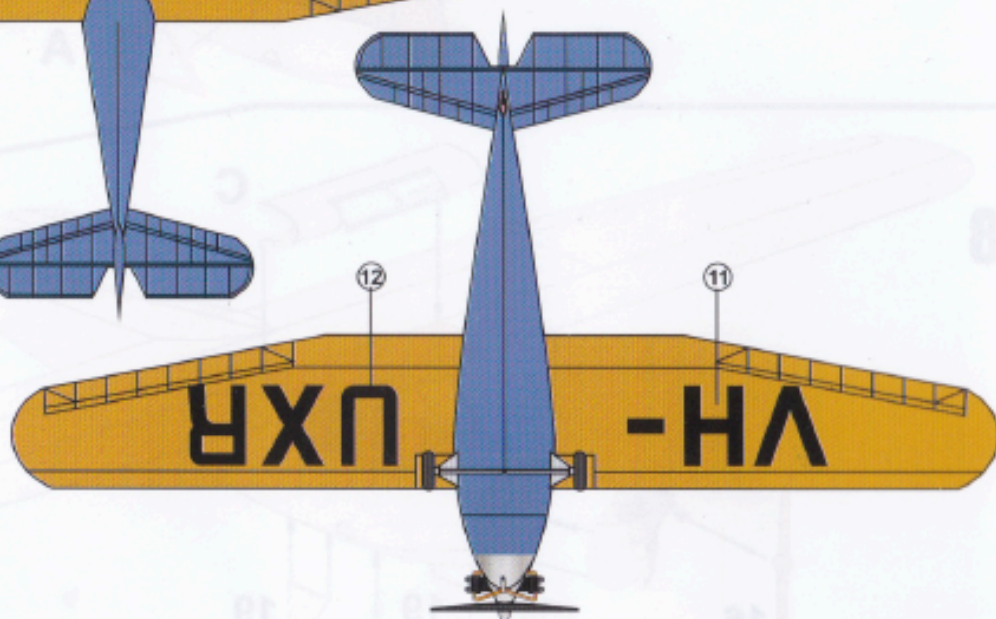
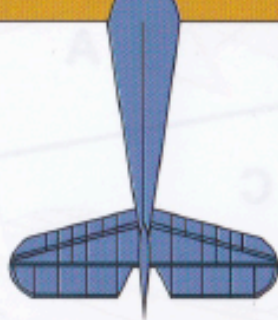
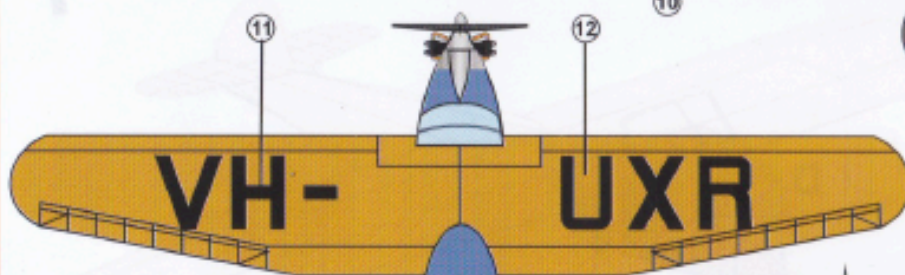
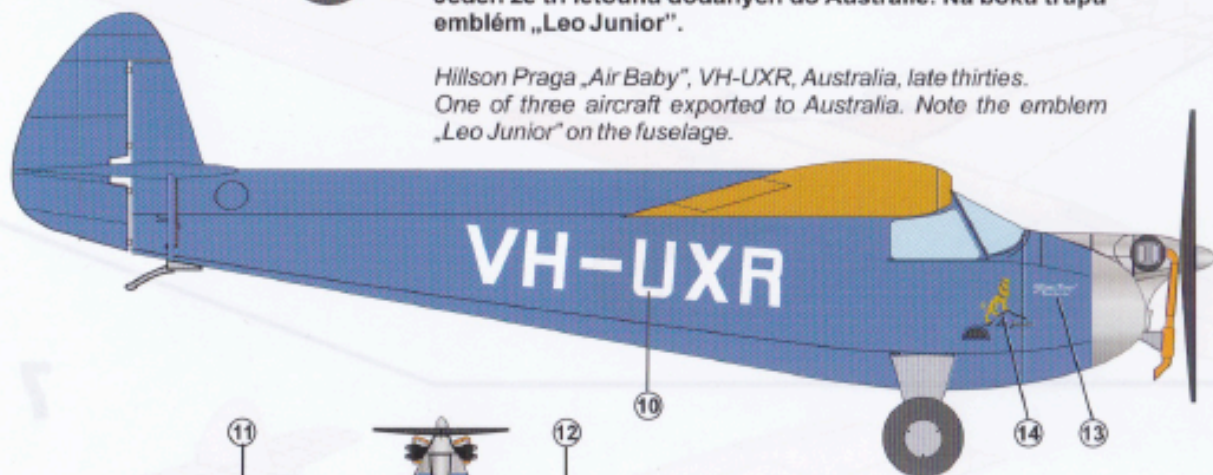

In co-operation  
 ve spolupráci



Použité barvy: / Paints used:

**HUMBROL** / **AGAMA**

14 18  
 Střední modrá  
 Mid Blue

56 46  
 Hliník  
 Aluminium

19 17  
 Překližka  
 Plywood

60 17  
 Červená  
 Red

22 14  
 Bílá  
 White

33 07  
 Černá  
 Black

14 15 16 17 18 19 20 21 22

G-AEUT 1 G-AEUT 2 G-AEUT 3 G-AEUT 4  
 G-AEUP 5 G-AEUP 6 G-AEUP 7 G-AEUP 8  
 G-AEUP 9 G-AEUP 10 G-AEUP 11 VH-VH-  
 VH-UXR 12 VH-UXR 13 UXRUXR 13  
 KPM 0094 HILLSON PRAGA

VH-UXR 10 VH-UXR 12  
 G-AEUT 1 G-AEUT 2  
 G-AEUP 5 G-AEUP 6

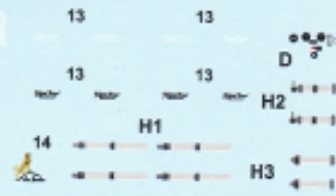

Hillson Praga E-114 KPM 0094