

Sd.kfz2
KLEINES

KETTENKRAFTRAD

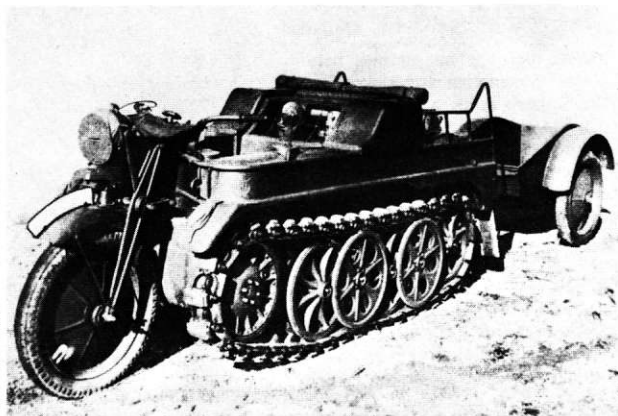

1/35 MILITARY MINIATURE SERIES



Throughout World War II, the Germans developed numerous types of fighting vehicles including tanks. Unarmoured transport vehicles were also remarkably diversified because the Germans immediately requisitioned those manufactured by occupied countries in addition to those developed by the Germans themselves.

A unique light vehicle among these diversified transport vehicles used by the Reichswehr was the Kettenkrad. This interesting, peculiar vehicle was officially designated "Kleines Kettenkraftrad (Small Tracked Motorcycle) Sdkfz 2", but generally called "Kettenkrad" for short.

The idea of such tracked vehicles with a steering wheel was born a fairly long time before. After World War I, Schneider of France initiated experimental study, which continued till mid 1930's.

When parachute troops for making surprise attacks appeared after the outbreak of World War II, light, small vehicles capable of towing infantry anti-tank guns naturally came to be required. At first the German Air Force tried towing these guns by the Army's motorcycles equipped with a sidecar, but they proved to have poor tractive force and were not qualified for use in actual fighting. Late in 1939, the German Ordnance Bureau decided to develop a multipurpose light tractor for parachute troops of the Air Force and ordered NSU to trial-manufacture it in accordance with the specifications given. NSU was a big manufacturer of motorcycles of 600 cc and other classes and once provided motorcycles for the Austrian Army. NSU immediately set to trial manufacture and completed a pilot model in 1940, starting to produce the Kettenkrad (HK-101) in 1941.

The body was of all-metal closed construction. An Opel-Olympia water-cooled series 4-cylinder OHV 1,478 cc petrol engine of 36 hp was mounted with the front side back on the center of the body. Under the driver seat in front of the engine were the clutch and transmission through which power was transmitted to the front sprocket wheel. The transmission offered three speeds forward and one backward. Also employed was two-speed auxiliary transmission for use in off-road running. Thus the vehicle had six speeds forward and two backward in all, which further enhanced its off-road performance. The suspension was of torsion bar type. The radiator was fixed at the back of the engine and the air intake was provided at the rear of the driver seat. The fuel tanks were mounted on both sides of the driver seat at the

front part of the body and had a total capacity of 42 litres. The performance was as follows: maximum speed on road of about 70 km/h, tractive force of 4.5 tons and cruising range of 260 km on road or 190 km off road.

On 5th June, 1941, the "Ramcke" Brigade, parachute troop, was equipped with the Kettenkrad for the first time in the German Army. At that time, the Germans succeeded in conducting large-scale airborne operations against Crete. This was the first time in history that an airborne troop had ever captured an island and achieved brilliant war results. No less than 25% of German soldiers were, however, lost in the successful operations. Ironically enough, the Kettenkrad which was supposed to be produced for parachute troops lost its original purpose. The unparalleled mobility of the Kettenkrad, however, naturally attracted ground troops' attention. There was a rapidly growing demand for the Kettenkrad particularly from those who were troubled with bad roads on the eastern front. The Kettenkrad, whose production once threatened to cease, was thus put to mass production again in 1943. It came to display considerable activity as a telephone-line layer or as a liaison vehicle to replace motorcycles. The production of the Kettenkrad (HK-101) continued till the end of 1944 and totalled to 8,345. A few Kettenkrad HK-102's equipped with a more powerful engine of 2,000 cc were manufactured for trial but not put to mass production.

Essential Specifications of the Kettenkrad (HK-101)

- * Overall length: 3.00 m
- * Overall width: 1.00 m
- * Overall height: 1.20 m
- * Weight: 1,235 kg
- * Engine: Opel-Olympia water-cooled series 4-cylinder OHV 1,478 cc, 36hp/3,400 rpm
- * Maximum speed: 72 km/h (on road), 40-48 km/h (off road)
- * Cruising range: 260 km (on road), 190 km (off road)
- * Tractive force: 4.5 t
- * Number of crew: 3

The "Ramcke" Brigade was an elite unit counted as one of the most outstanding parachute troops. There is a dramatic episode that the Brigade — which, after capturing Crete, was sent to North Africa — had only a limited number of vehicles and anti-tank guns there but ran through the enemy for a distance of 350 km and successfully escaped all by itself.

PAINTING & APPLYING DECALS





(Colour of German Military Vehicles)
 From February 1943, German military vehicles became to be camouflage-painted in dark yellow as the main colour using red brown and dark green, while they had been painted in single german grey till that time. Those of tank divisions in Normandy on July 1944 were also painted in these three colours single or combined. They did not have any uniform camouflage pattern, but were painted freely with a

brush or a spray-gun. While some vehicles found painted in german grey in this period. This seems that they used german grey paint stocked so far through the shortage of paint. And on the African front, their colour were either in single dark yellow or added with red brown camouflage in accordance with the land. In winter many vehicles were used with flat white water-soluble paint applied on body colour.

(Colours to be Used)
 Flat Black
 Flat White
 Metallic Grey
 Buff
 Dark Yellow
 German Grey
 Red Brown
 Field Grey

Camouflage Pattern in Two Colours

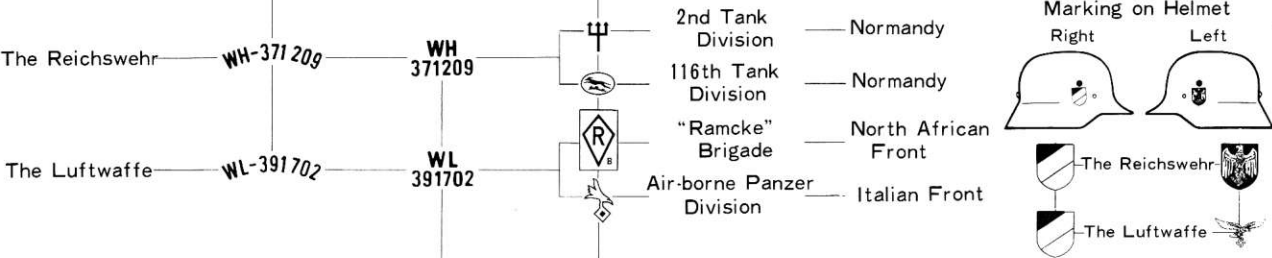
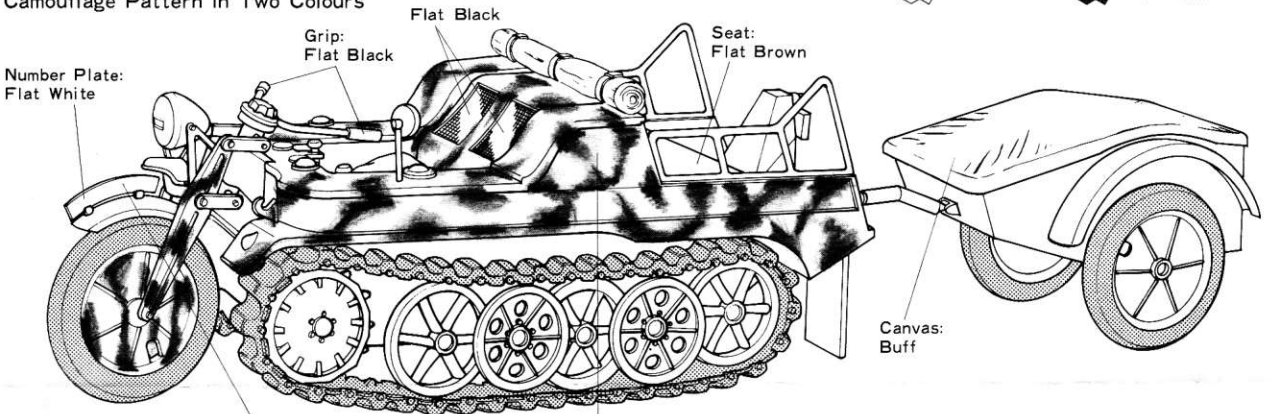

Camouflage Pattern in Three Colours

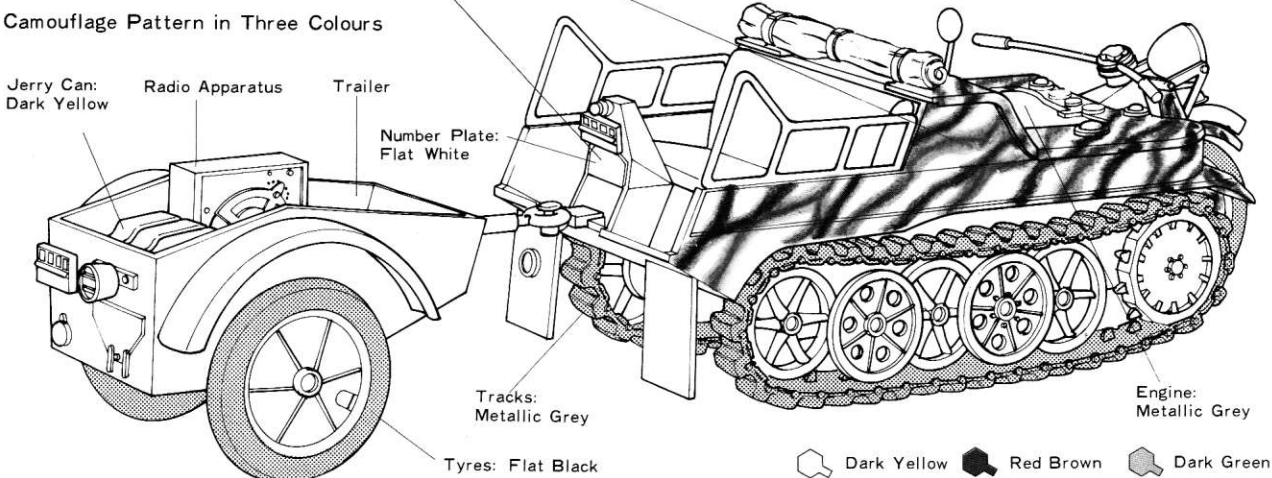



★Please read the instructions before you start assembling a model.

★Get a sharp knife, a pair of nippers, and a file etc. ready.

★Do not ripple away each part from a runner. Cut parts off from runners with a pair of nippers or a knife.

Painting Your Model

★As well as improving the reality of your completed model, painting will give you greater satisfaction to make your own model. Moreover, paint coat ensures a good application of Decals.

★Small parts and internal parts should be painted while still on the runner.

(Figures Assembly) Driver

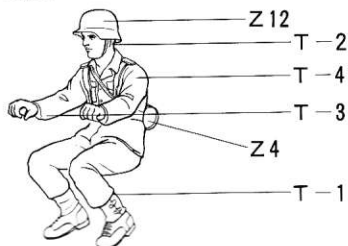

Foot Soldier (A) Can be assembled into two poses.

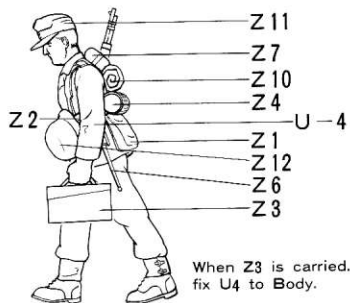
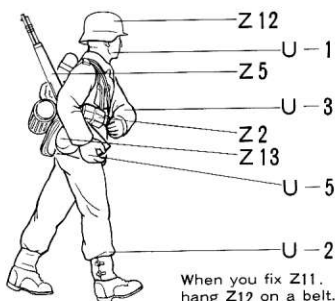

Foot Soldier (B) Can be assembled into two poses.

1 Front Fork Assembly

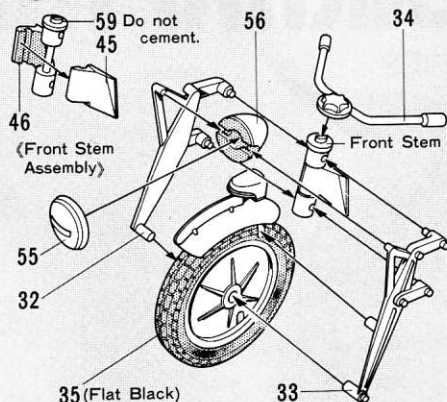

2 Trailer Assembly

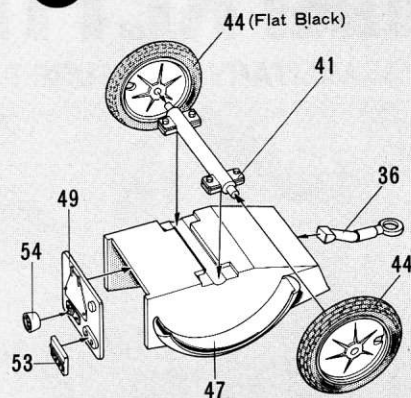

3 Side Panels Assembly

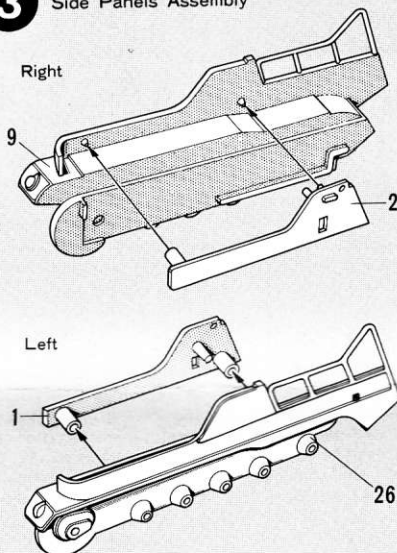

4 Floor Pan Assembly

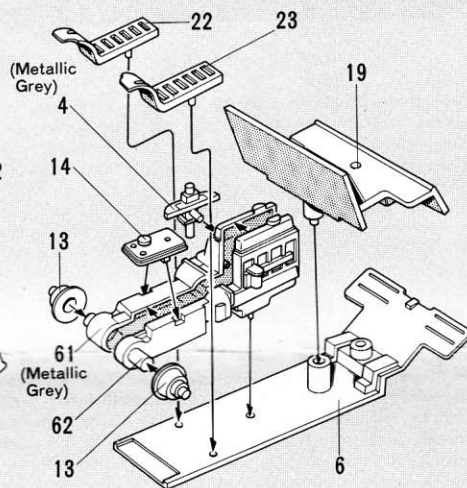

5 Construction of the Body

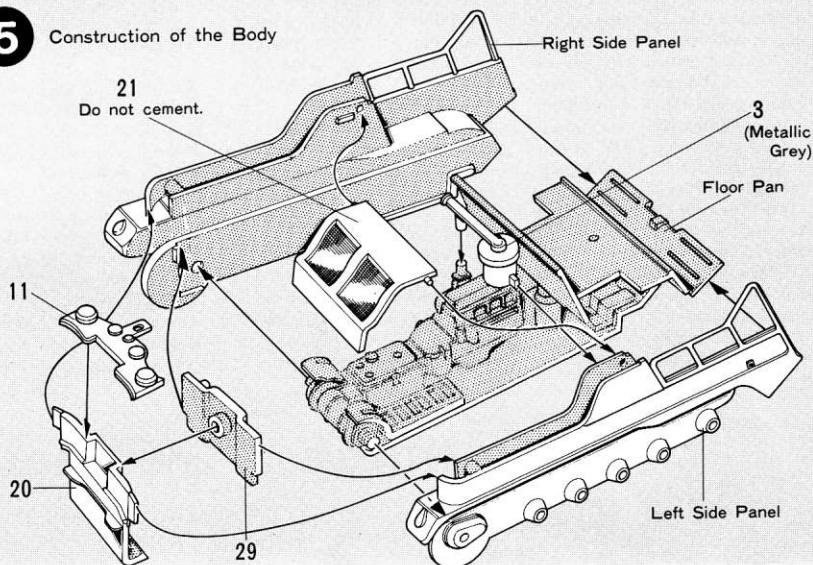

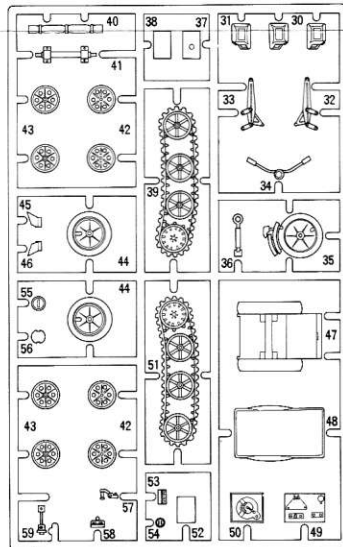
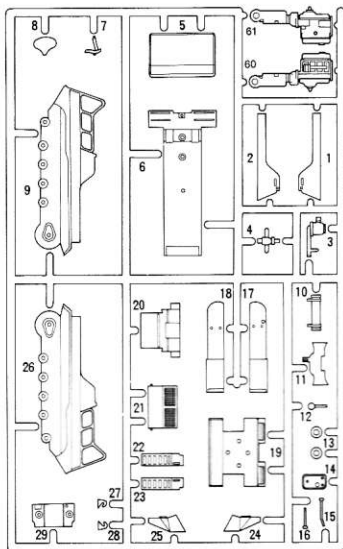
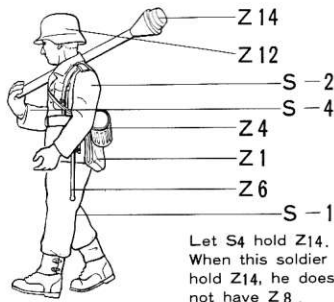
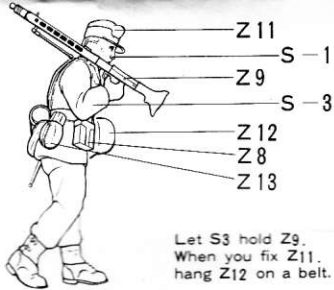

6 Fixing Rear Seat

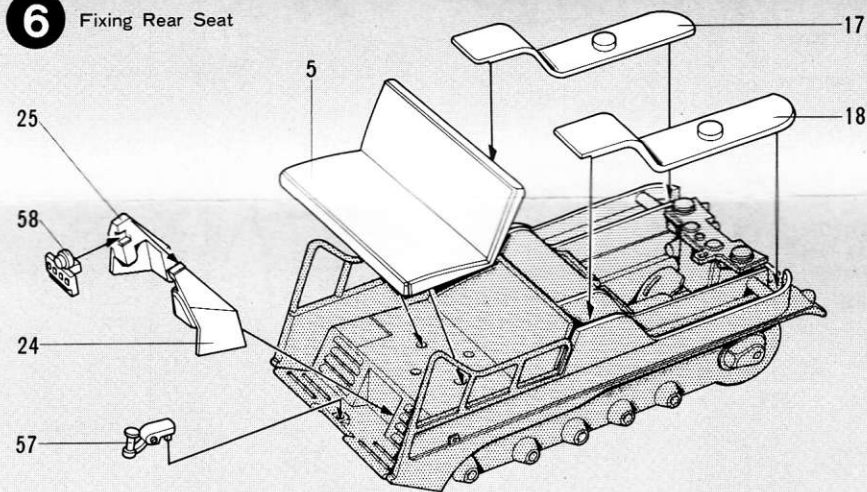

7 Fixing Tracks and Wheels

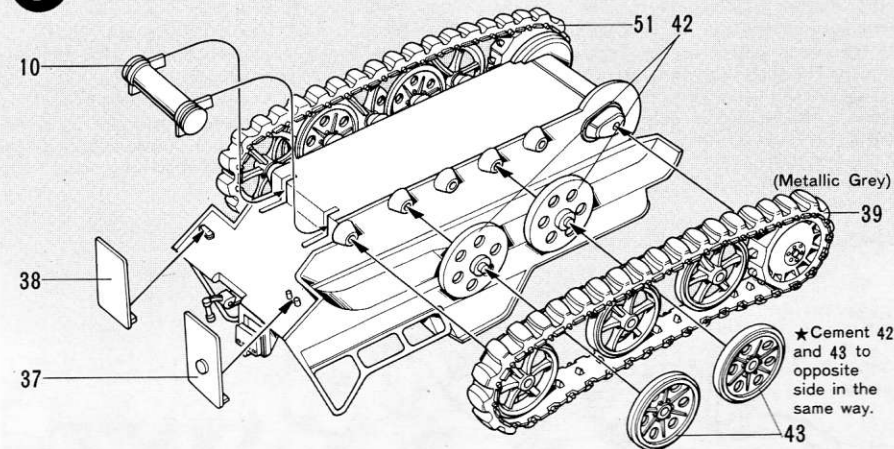

8 Completion of the Body

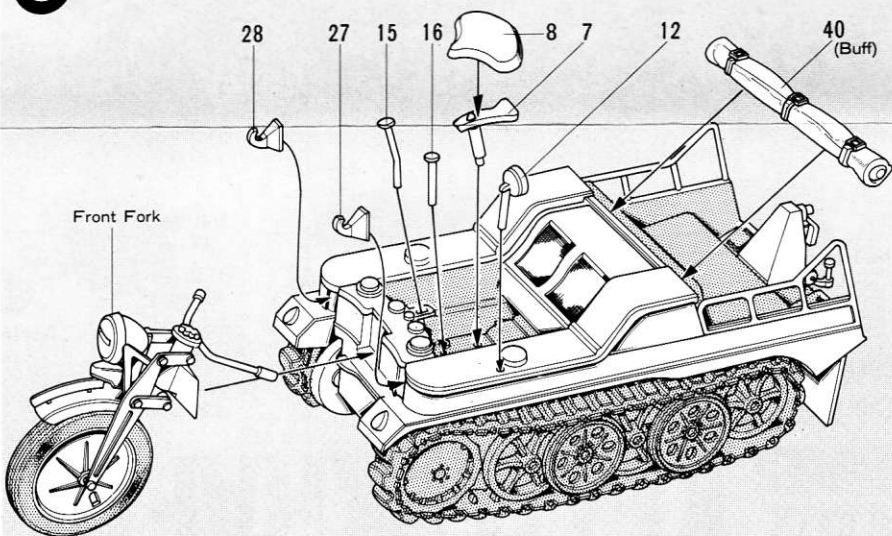

9 Connecting Trailer

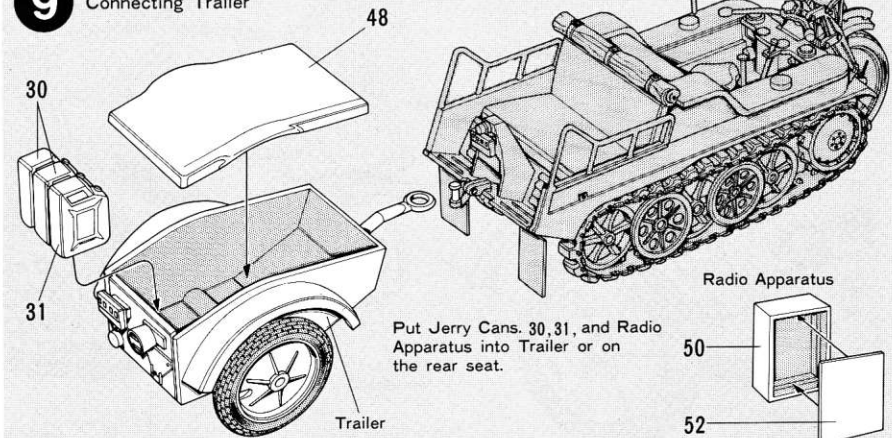

TAMIYA COLOR CATALOGUE

The latest in cars, boats, tanks and ships. Motorized, radio controlled and museum quality models are all shown in full color in Tamiya's latest catalogue. At your nearest hobby supply house.

