

ACADEMY

HOBBY MODEL KITS

M-12 155mm GUN MOTOR CARRIAGE

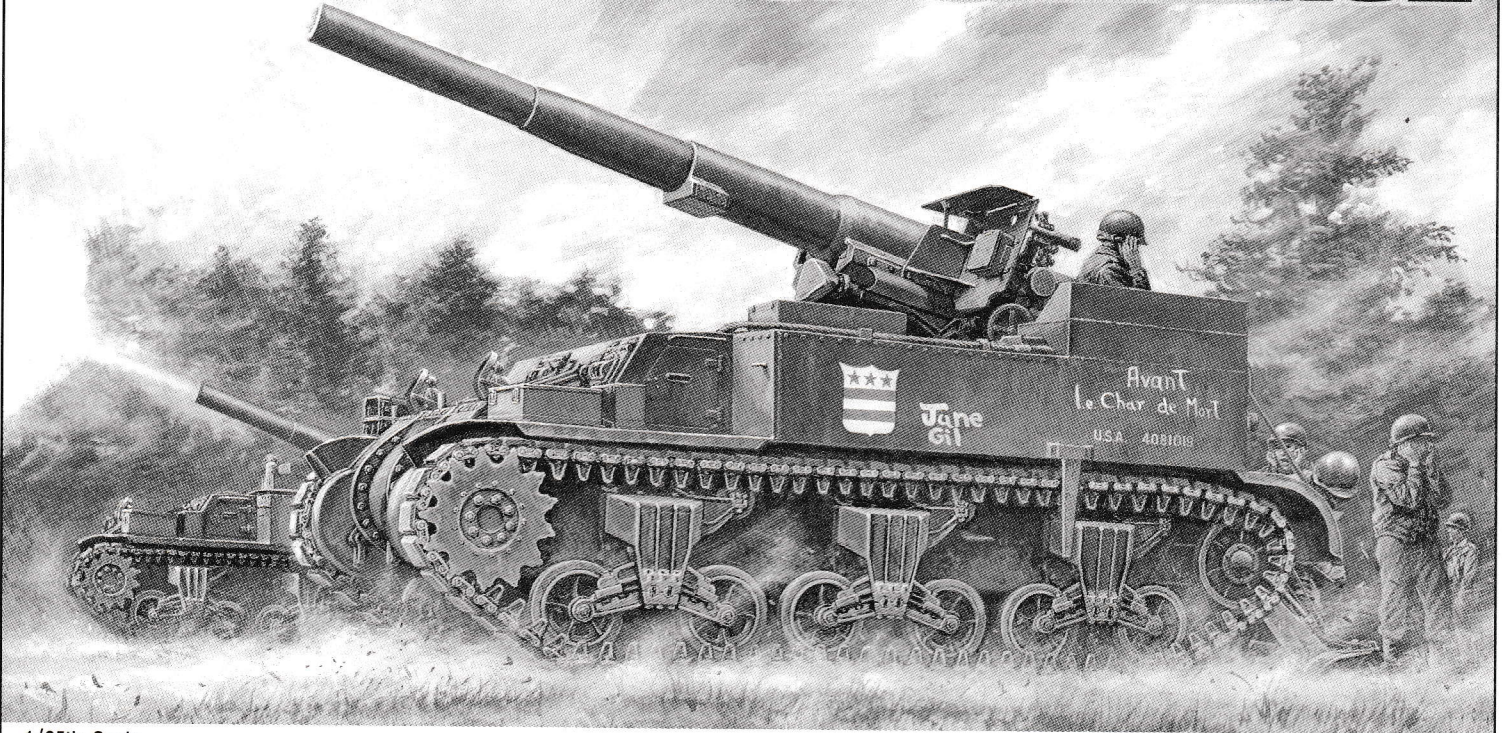

1/35th Scale

TA988/#1394

M-12 155mm 자주포 전차

As World War 2 began in Europe and it was clear that America would be drawn into the war it was decided that the US Army must develop a self propelled gun. Engineers enlisted the World War 1 veteran the French 155mm gun as their choice. They also chose the M3 Lee tank chassis as the basis for the design.

The M12's ordered were used for training purposes only. In 1943, with the invasion of Europe imminent, the US Army decided to have the M12's upgraded for possible use in overseas theaters. The heavier suspension of the M4 with rear mounted return roller was used to modernize the vehicle. Baldwin Locomotive Works, the company updating the units, also mounted a small shield on the gun mount and removed the co-drivers's hatch. With an elevation of -3° to +35° and traverse capabilities of 28° to 14° the 155mm gun on the M12 carried ten rounds of artillery and had a maximum range of 15,200 yards. A 353 horsepower air-cooled Continental R975 radial engine yielded a maximum speed of 24 miles per hour. In June of 1944 they were sent to Europe and used for several major battles including the taking of Cologne.

Als beim Ausbruch des zweiten Weltkrieges klar wurde, das ein Mitwirken der vereinigten Staaten unvermeidlich war, entschied sich die U.S.Army zur Entwicklung einer Selbstfahrlafette. Die Ingenieure Wählten die 155mm Kanone, eigentlich ein Veteran aus dem ersten Weltkrieg, als geeignetes Geschütz aus. Das M3 Lee Chassis diente als Basis dieser Entwicklung. Als M12 bezeichnet, verwendete man die ersten Exemplare nur für Trainingszwecke. Da jedoch ab 1943 Landungsunternehmen auf europäisches Gbiet immer konkreter wurden, begann die U.S.Army mit entscheidenden Verbesserungen. Diese Modernisierung, ausgeführt von den Baldwin Locomotive Works, umfassten u.a.das schwerere Fahrwerk des M4 mit rückwärtig versetzten Stützrollen,ein kleines Schutzschild für die Bedienung sowie das Entfernen der Belfahrerluke. Der Höhenrichtbereich der 155mm Kanone betrug -3° bis +35° und der seitliche Schwenkbereich umfasste 28° bis 14°. Als Munitionsvorrat führte man 10 Granaten mit und die Reichweite der projektiler betrug über 15000m. Den Antrieb des M12 übernahm ein luftgekühlter Continental R975 Sternmotor mit 353 PS, die Höchstgeschwindigkeit betrug 38 km/h. Ab Juni 1944 erfolgte der Truppendienst des M12 in vielen entscheidenden Gefechten einschliesslich der Einnahme von Köln.

欧州で第2次大戦が勃発した時、米国が戦争に引き込まれるであろうことは明白でありました。そこで、米陸軍は自走式大砲を開発する必要があると決定されました。技術者は、第1次大戦のベテラン、フランスの155ミリ砲を選択してリストに挙げました。又、彼らは設計の基本として、M3Lee戦車の車台を選びました。発注されたM12自走砲は訓練目的のみに使用されました。1943年、欧州への侵略がすぐにも始まりそになった時、米陸軍は、海外の戦域での使用の可能性に備え、M12自走砲の改良型の保有を決定しました。後部に搭載されたリターン・ローラーとともにM4戦車のより重量があるサスペンションが、M12自走砲を近代化するために使われました。同兵器の改良に従事したBaldwin Locomotive Works社は、砲架台に小さな遮蔽板を装着し、副運転手のハッチを取り除きました。-3度から35度までの高さを変えられることおよび28度から14度までの旋回角を持つM12自走155ミリ砲は、砲弾10発を携行し、最大射程約14kmの能力を持っていました。353馬力のContinentalR975式空冷星型エンジンは、最大時速38.6kmを出すことが出来ました。1944年6月、同自走砲は欧州に送られて、コロンの奪取を含むいくつかの主要な戦闘で使用されたのです。

미국의 2차대전 참전과 더불어 미육군은 자주포의 개발을 결정하게 되었다. 프랑스제의 M1917 155mm포를 주포로 채용하며, 차대는 당시로서는 신형인 M3전차의 차체를 이용했다. M-12는 1943년, 본격적인 유럽본토의 진입에 발맞추어 실전에 투입할 수 있도록 일부 성능의 개량이 이루어지게 된다. 볼드윈 로코모티브 워크스는 차량의 현대화를 위해 리턴롤러를 후면에 장착한 M4전차의 신형 헨가장치를 채용하며, 포측면에 작은 포방패를 장착하고 조수석의 측면해치의 폐지 등 차량의 일부를 개수했다. M-12의 최대 사거리의 약 14km에 이르며 353마력의 공냉식 콘티넨탈 R975 래디얼 엔진의 장착으로 최대속도 시속 38.6km를 낼 수 있다. M-12는 1944년 6월 유럽전선으로 투입되어 독일 쾰른 탈환전투 등 여러 중요한 전투에 사용되었다.

<READ THIS BEFORE YOU BEGIN>

- Study the instructions before assembling. - Check the fit of each piece before cementing into place.
- Do not use too much cement to join parts. - Never use cement or paint near open flame.
- Open a window or make area well ventilated when cement or paint is in use.
- Tear up and throw away the empty plastic bags to avoid danger of suffocation for little children.

<ALLGEMEINE HINWEISE>

- Die Anordnung der Bauteile ist aus den Zeichnungen der Anleitung ersichtlich.
- Die Teile vor dem Verkleben ungeleimt zusammenhalten, um ihren paßsitz zu prüfen.
- Klebstoff nicht zu dick auftragen. - Klebstoff und Farben niemals in der Nähe einer Flamme verwenden.
- Während der Bemalung mit Spritzpistole oder Pinsel für frische Luftzufuhr, z.B. öffnen des Fensters, sorgen.
- Bausatz von kleinen Kindern fernhalten. Verhüten Sie, daß Kinder irgendwelche Bauteile in den Mund nehmen oder Plastiktüten über den Kopf ziehen.

■ 조립하기 전에

- 부품을 조립하기 전에 설명서를 잘 읽어본 후 조립한다.
- 접착하기 전에 부품을 맞추어 확인한 후 조립한다.

- 부품을 지를 때에는 칼이나 니퍼로 깨끗이 잘라준다.

- 에나멜 페인트나 접착제를 사용할 때는 장갑을 얹어 환경을 지키고 화기를 멀리한다.

<LISEZ CE QUI SUIT AVANT DE COMMENCER LE MONTAGE>

- Etudier les schémas d'assemblage. - Contrôler que chaque pièce soit bien conforme avant de la coller à sa place.
- N'utilisez pas trop de colle pour réunir les pièces. - Ne faites manipuler la colle ou peinture à proximité d'une flamme.
- Aérer soigneusement la pièce où vous peignez(ouvrir la fenêtre). - Après avoir sorti les pièces du sac en plastique, déchirer le sac afin d'éviter que les enfants ne le mettent sur la tête et ne s'étouffent.

<組み立てる前に>

- 組み立てる前に説明書をお読み下さい。 - 部品をランナーから切りはずす時は模型用ニッパーとカッターを使用します。
- 接着剤を少なめに使うことがきれいに仕上げるコツです。 - 接着する前に部品を合わせて確かめます。
- 接着剤や塗料を使用する時はときどき窓を開けて換気に気をつけましょう。
- 組み立てる後の部品やビニール袋は小さな子供の手の届かない安全な所に保管して下さい。

- 접착제를 사용할 곳과 사용하지 않는 곳에 주의하고 너무 많이 바르지 않도록 한다.

- 사용 후 남은 부품은 어린 아이들의 손에 닿지 않도록 잘 처리한다.

■ Parts Locating Diagram 부품도

A × 2

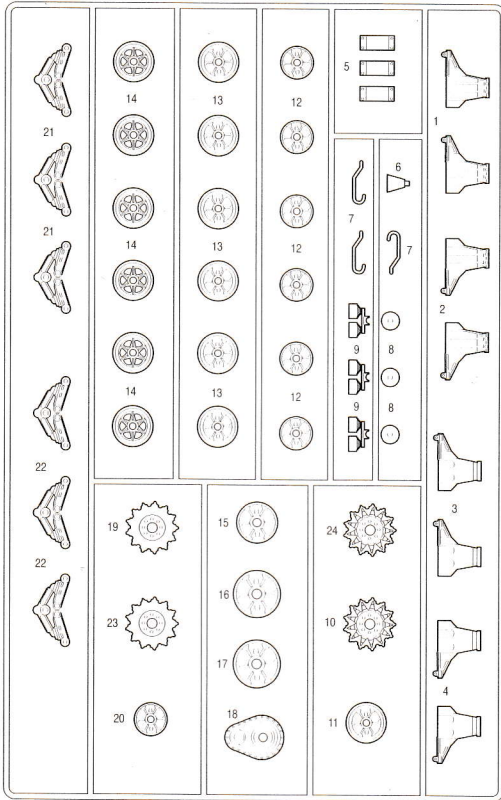

B

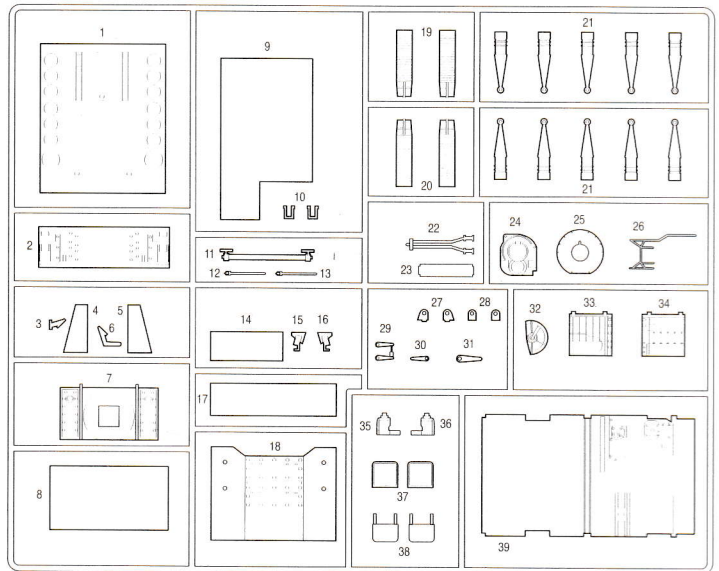

C

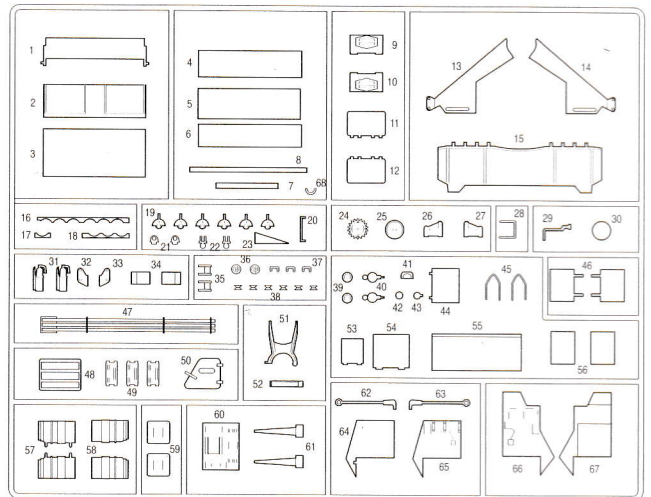

E

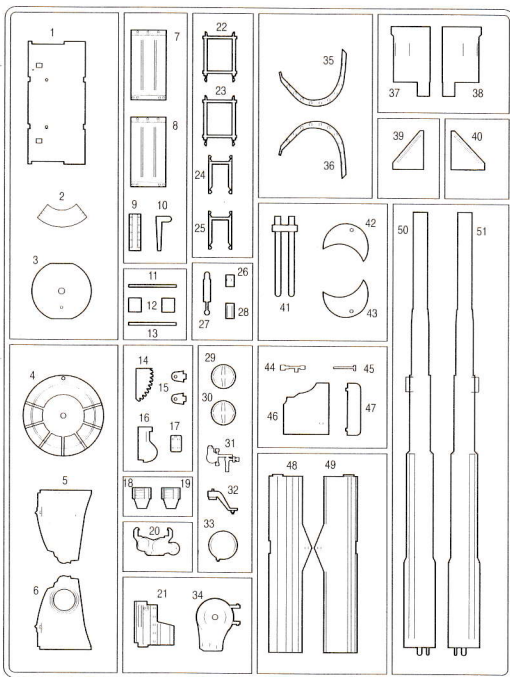

D

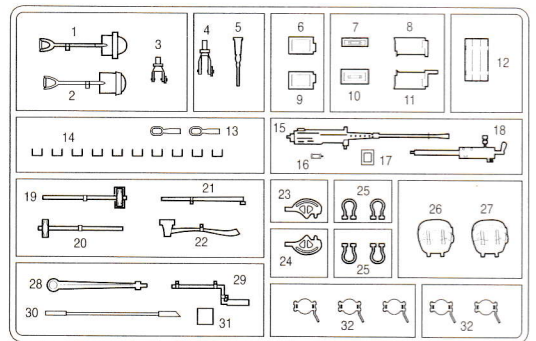

1	FLAT WHITE	MATTWEIß	BLANC MAT	つや消しホワイト	무광흰색
2	FLAT BLACK	MATTSCHWARZ	NOIR MAT	つや消しブラック	무광검정색
3	RED	ROT	ROUGE	레드	빨강색
4	KHAKI	KHAKI	KAKI	카키	카키색
5	SILVER	SILBER	ARGENT	실버	은색
6	METALLIC GRAY	GRAUMETALLIC	GRIS MÉTAL	메탈릭그레이	흑철색
7	LIGHT BROWN	HELLBRAUN	BRUN CLAIR	라이트브라운	라이트브라운
8	OLIVE DRAB	BRAUNOLIV	VERT OLIVE	올리브트랩	국방색

■ Unused parts : A1,2,3,4×1,11,20×2
 불필요 부품 D1,3,4,6,7,8,9,10,11,14×3,15,16,17,18,20,23,24,26,27,29,30,31,32×3

- Upper Hull 상체 × 1
- Lower Hull 하체 × 1
- Flexible Track 연결캐터필러 × 2
- Thread 실 × 2
- Decal 전사지 × 1



점착한다.
Cement parts
Coller
Kleben
Pegar
Incollare
Colar
Kleven



점착하지 않는다.
Do not cement
Ne pas coller
Nicht kleben
No pegar
Non incollare
Nao colar
Niet kleven



수반를 조립한다.
Repeat operation
Répéter l'opération
Vorgang wiederholen
Repitir la operación
Ripetere
Repitir a operação
Herhalen



전사지를 붙인다.
Decals
Decalcomanias
Abziehbild



무게추를 넣는다.
Add weight
Lester
Gewicht



구멍이나 홈을 채워준다.
Use filler
Mastiquer
Schleifen



잘라낸다.
Cut away
Couper
Schneiden
Cortar
Tagliare
Cortar
Snijden



선택한다.
Optional parts
Choix
Auswahlmöglichkeit
Elección
Scelta
Opcao
Keuze



반대측도 조립한다.
Repeat for opposite side
Répétition de la page
Wiederholung für gegenüberliegende Seite



구멍을 뚫어준다.
Make hole
Faire un trou
Öffnen



주의한다.
Be careful
Faire attention
Hier Vorsicht



색칠 및 전사지 붙이기 번호
Painting scheme number
Numeros de la liste de peintures
Lackierschemanummer

1

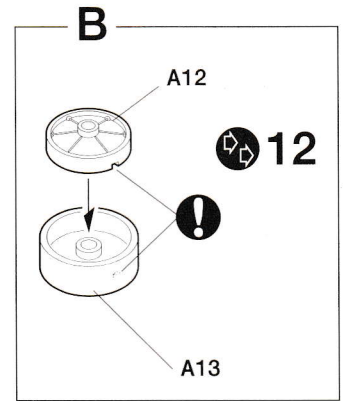
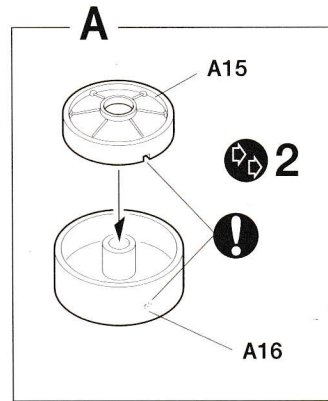
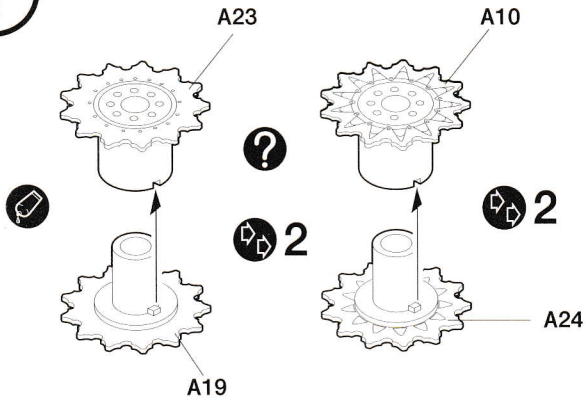

* () is opposite number.
()는 반대측 번호임.

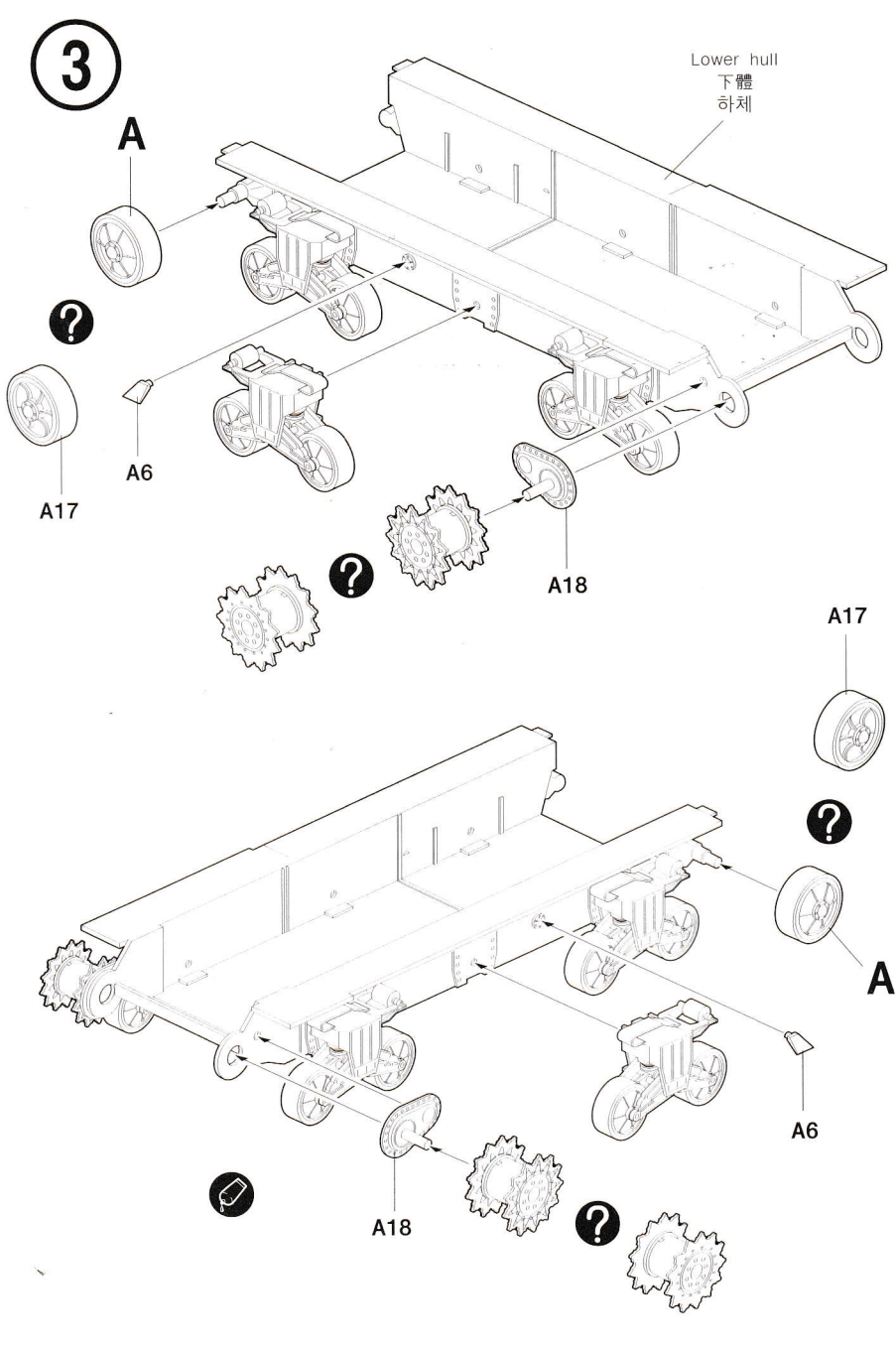
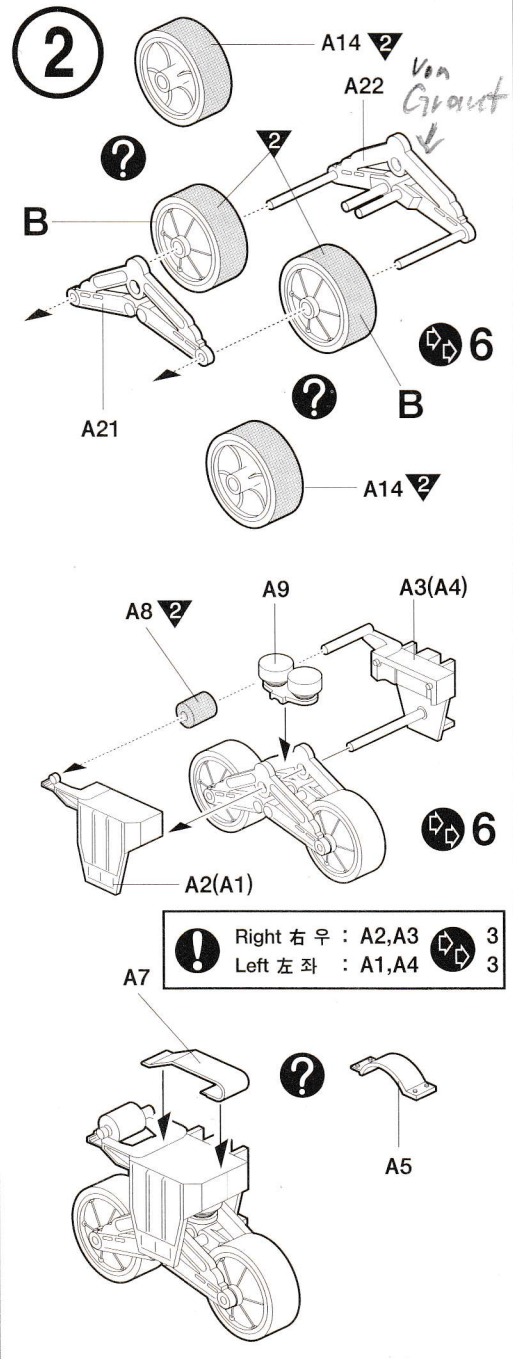

4

* INTERIOR COLOR
車體內部色 : ▼
차체내부색

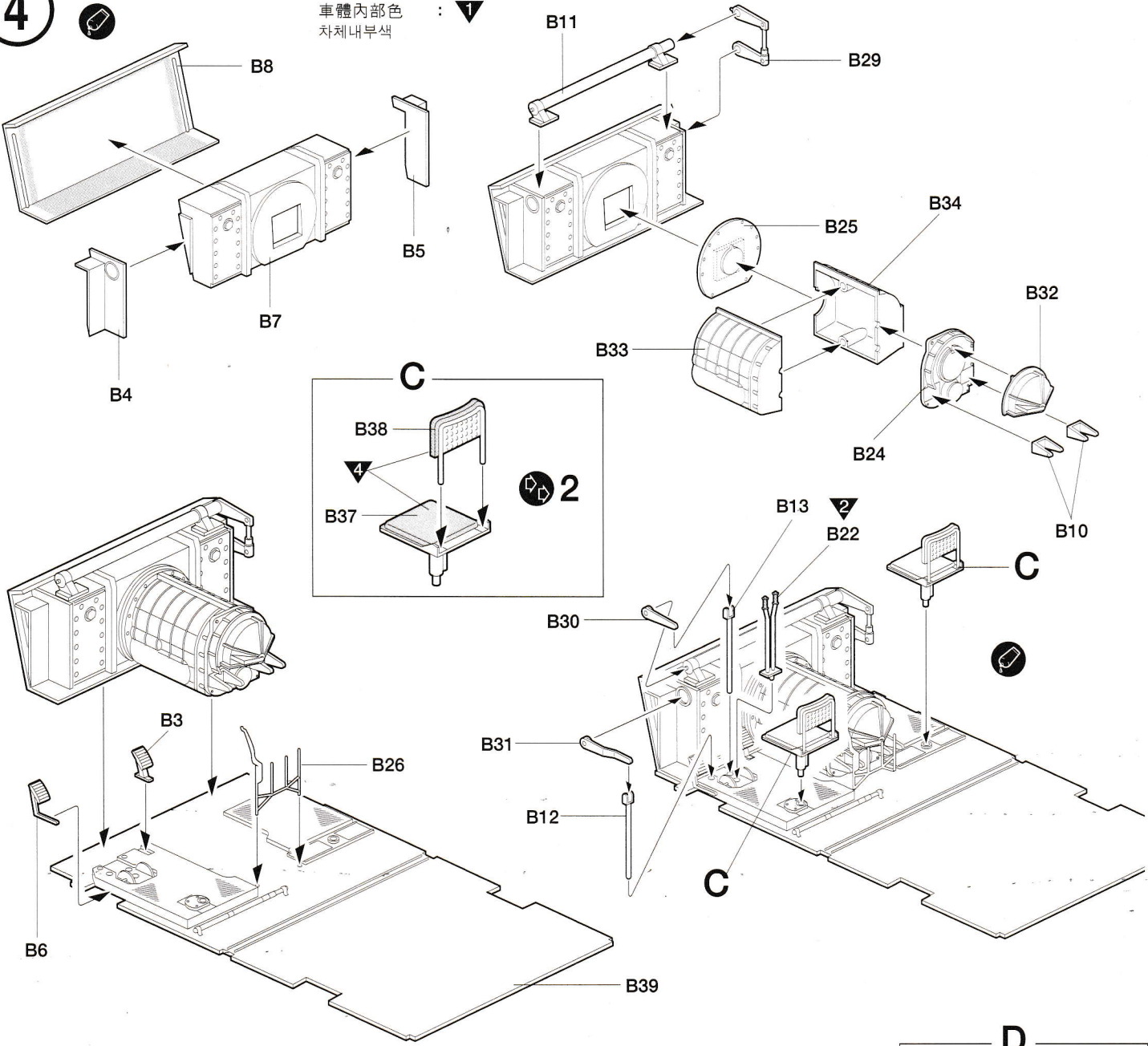

5

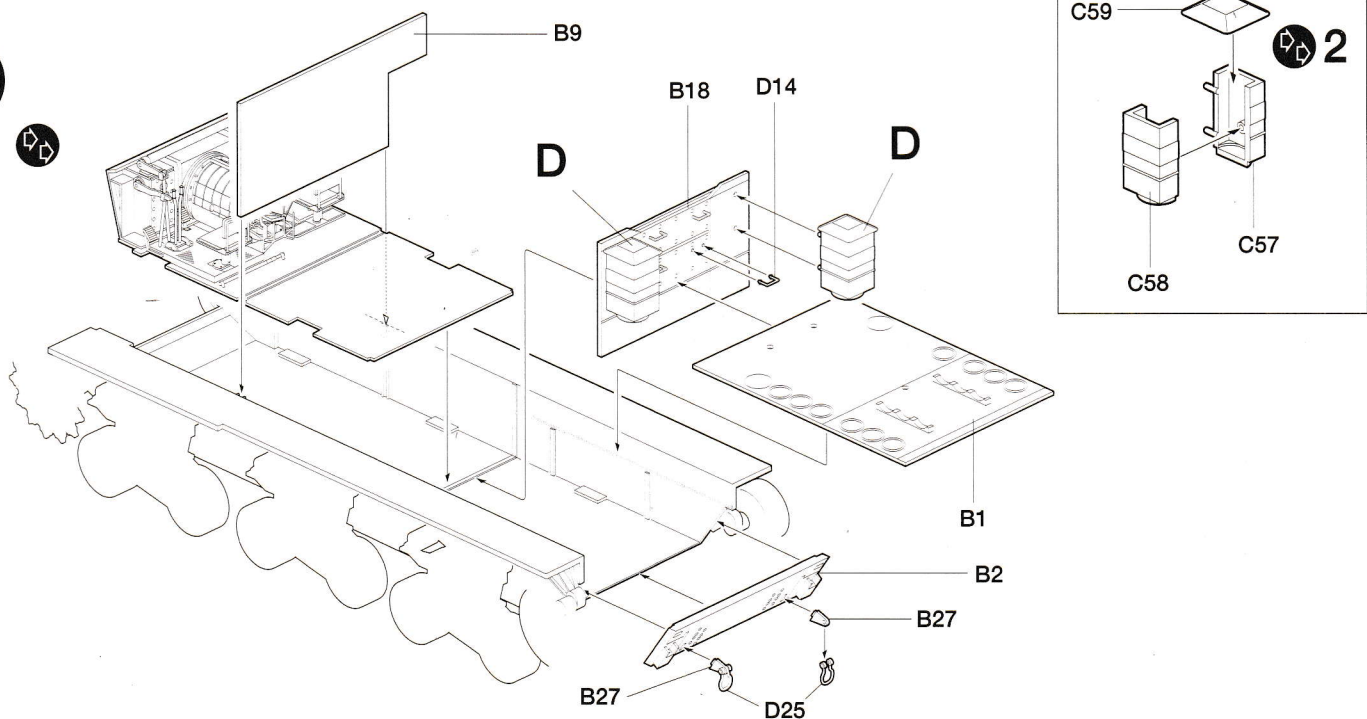

6

<Tracks キャタピラ 캐터필러>

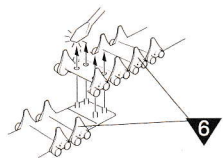

* Melt pins together with a heated screw driver.
볼에 달군 드라이버 등으로 핀을 녹여 고정시켜 연결한다.

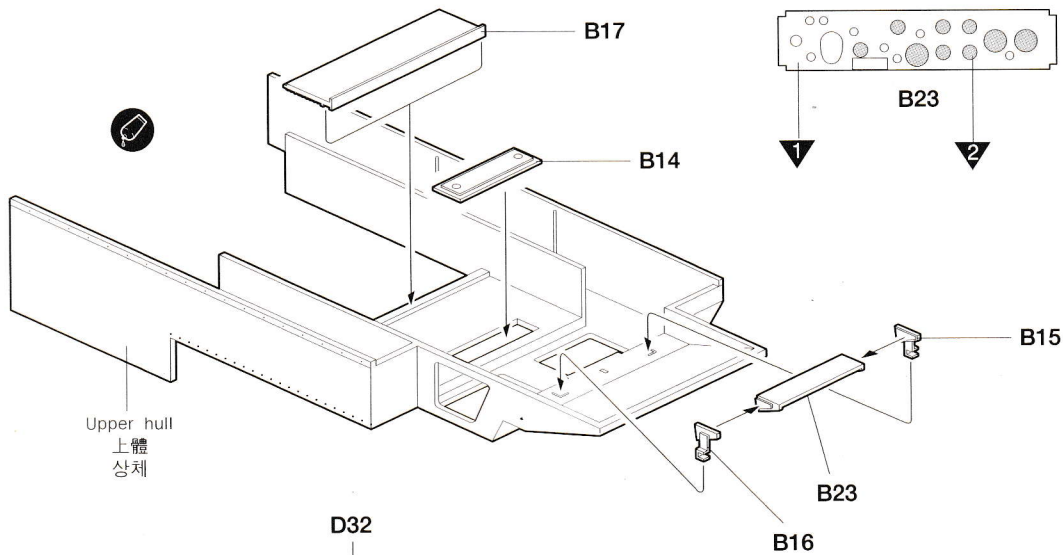

7

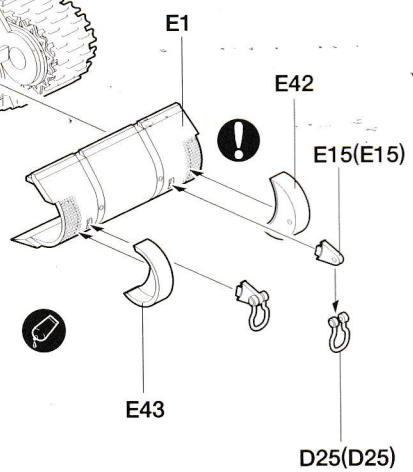
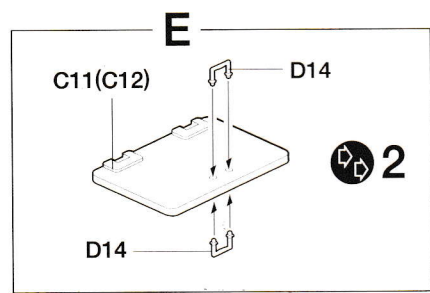
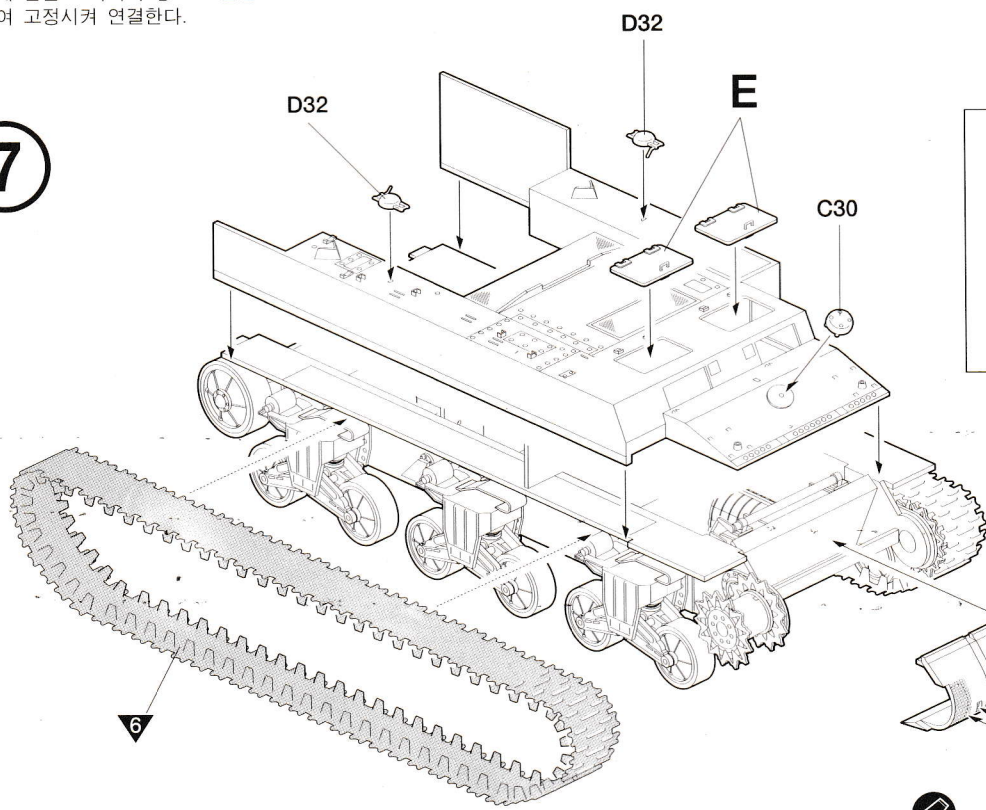

8

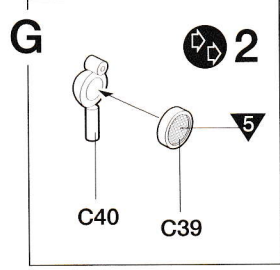
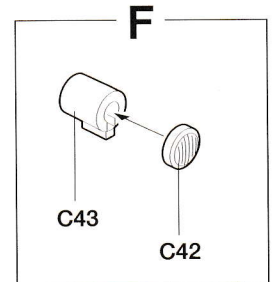
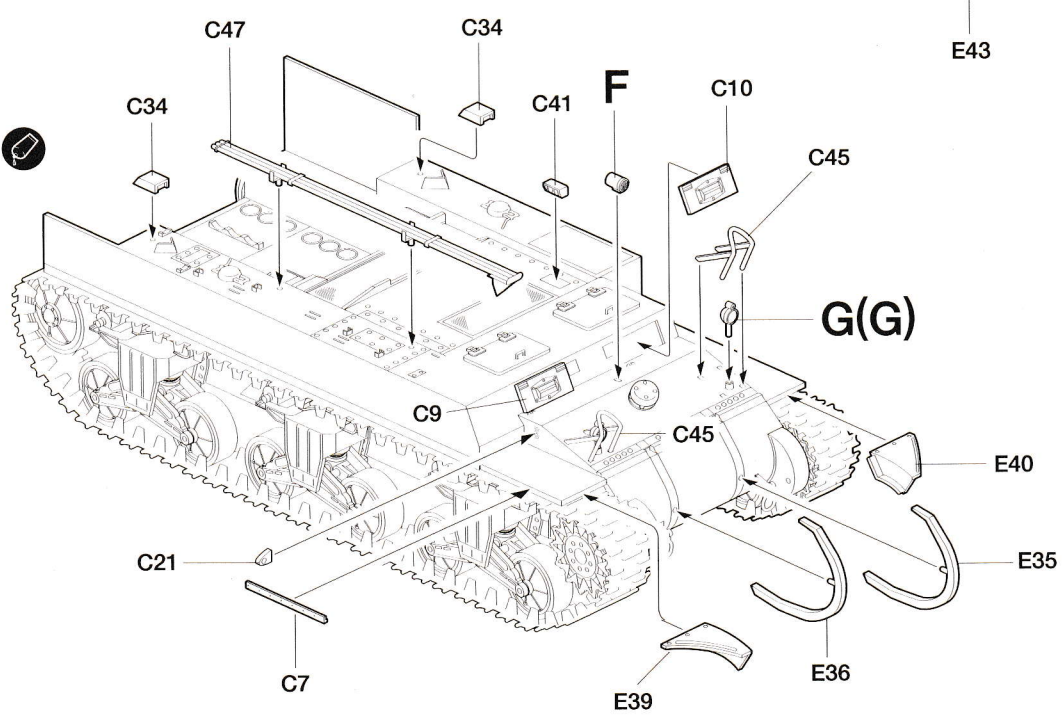

9

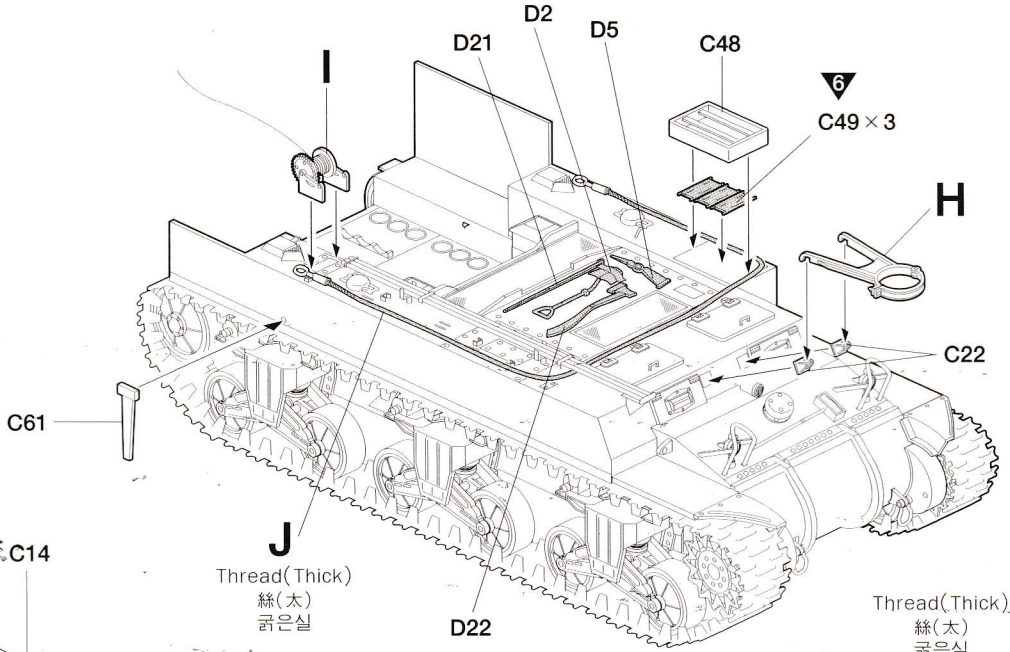
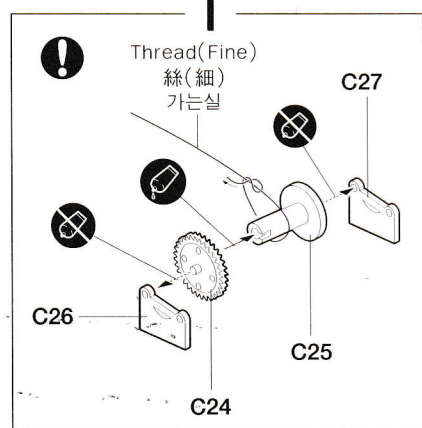
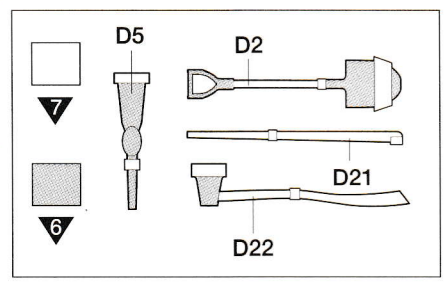
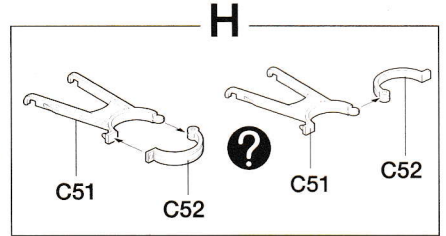
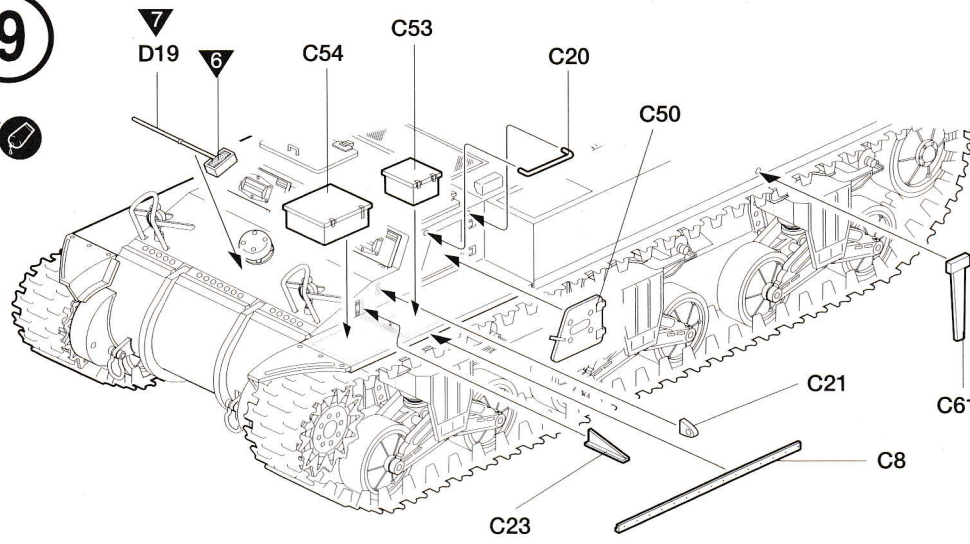

10

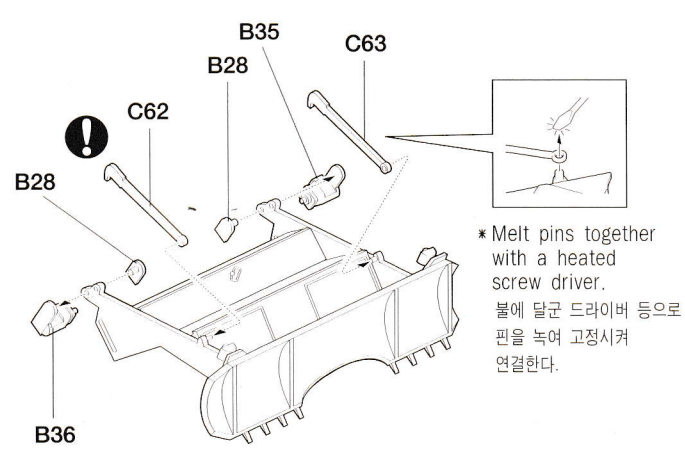
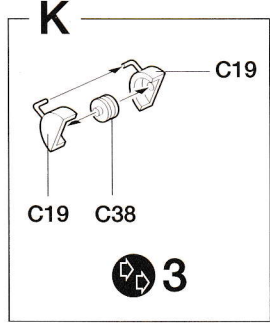
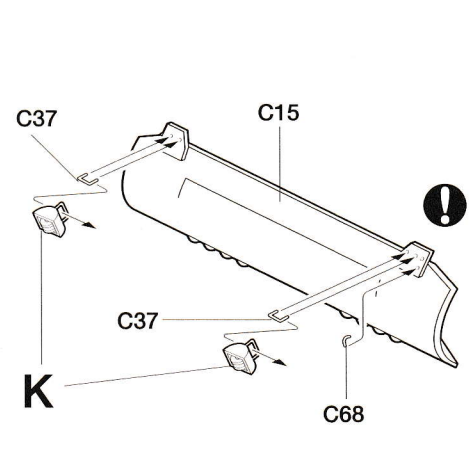
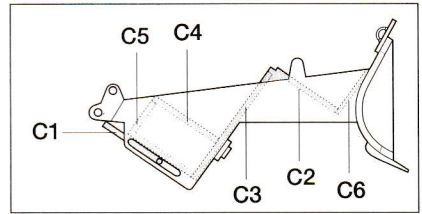
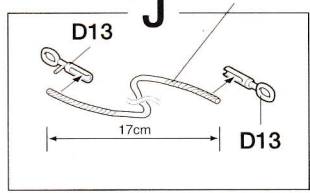
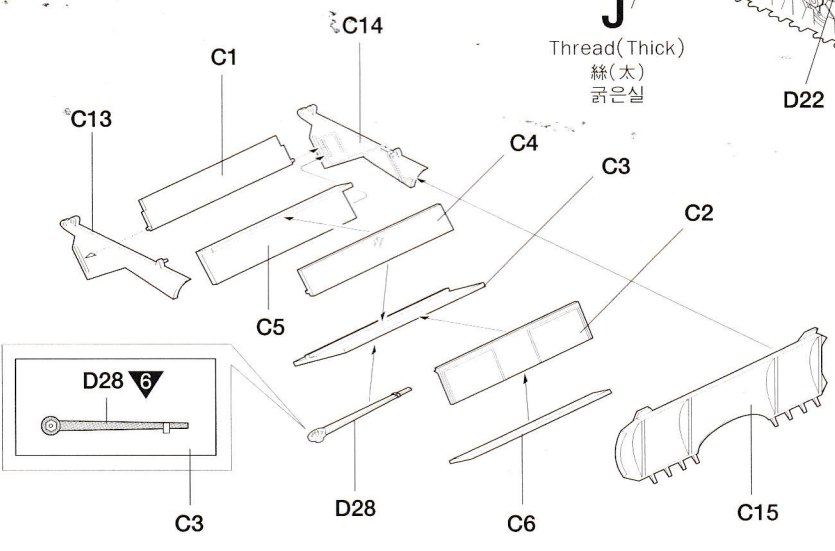

11

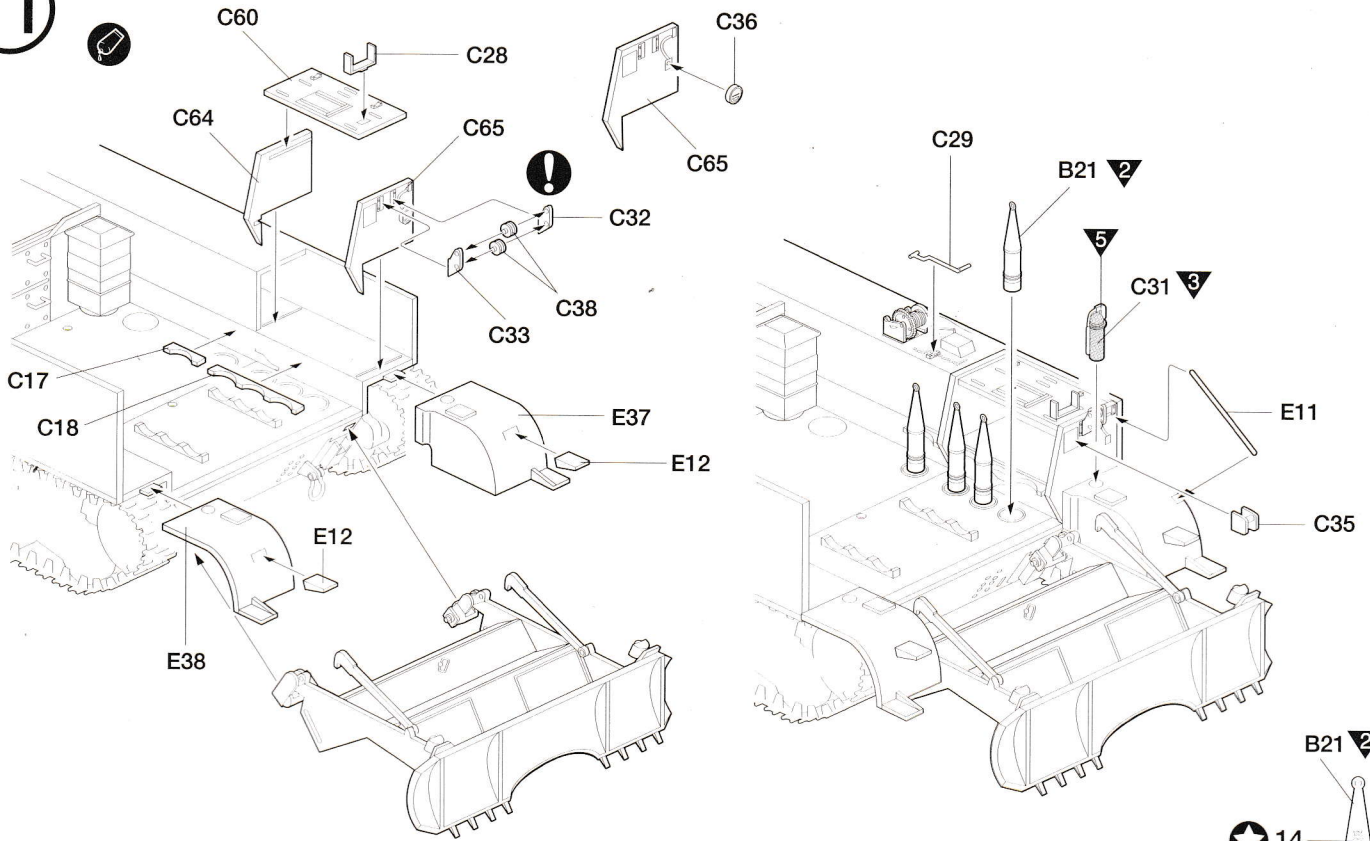

12

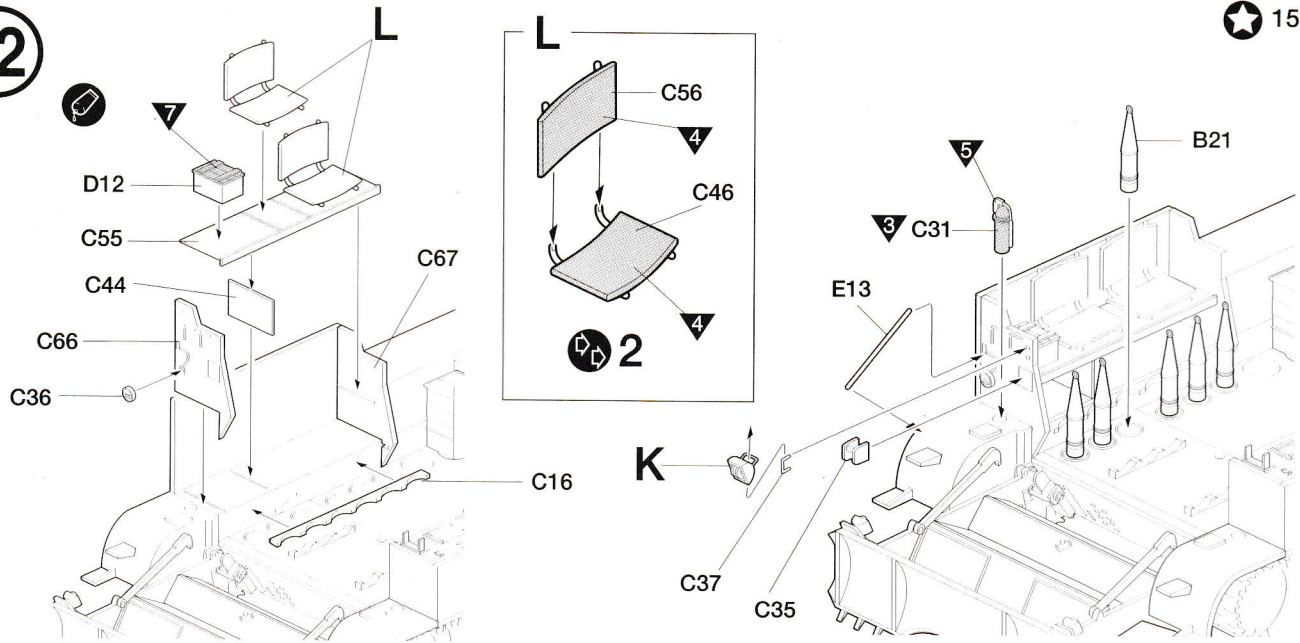

13

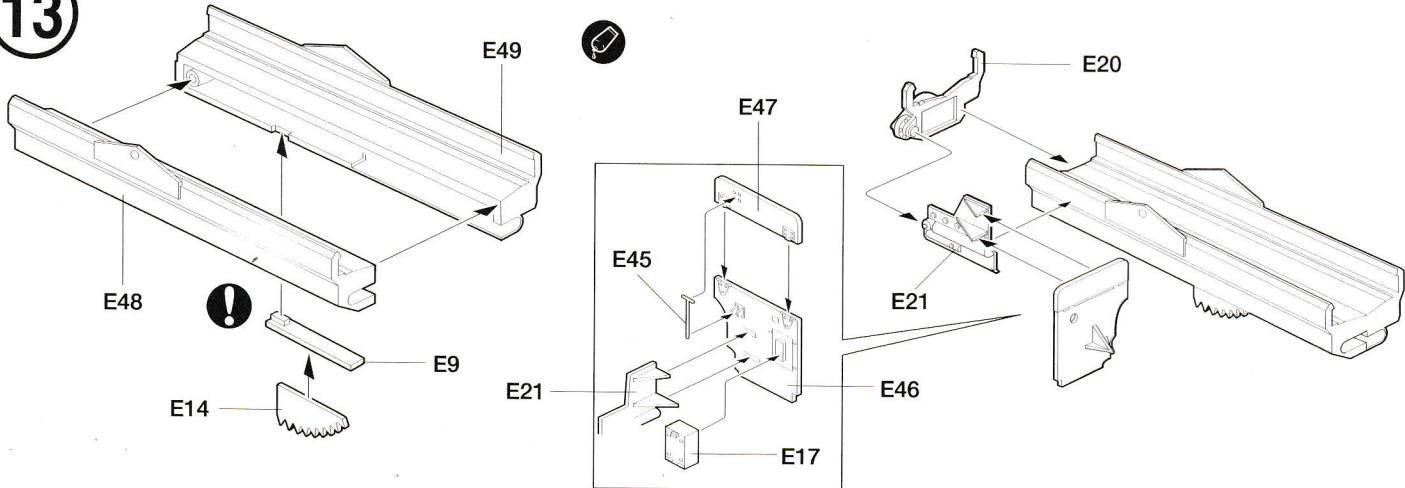

14

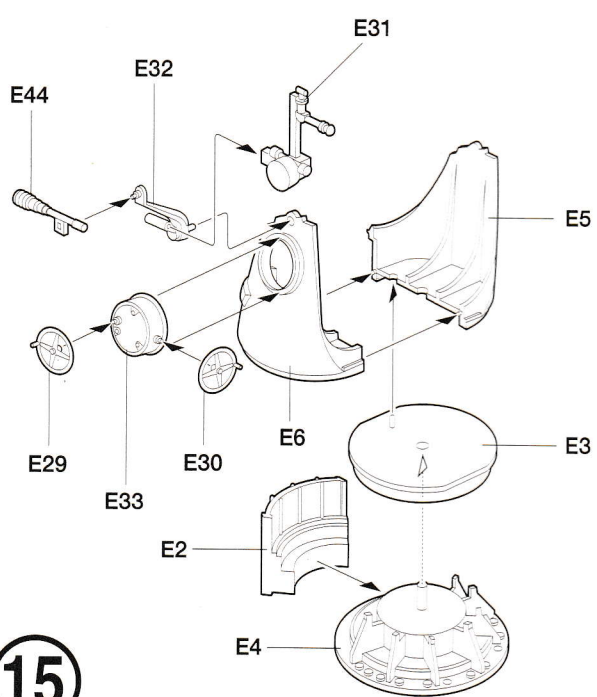
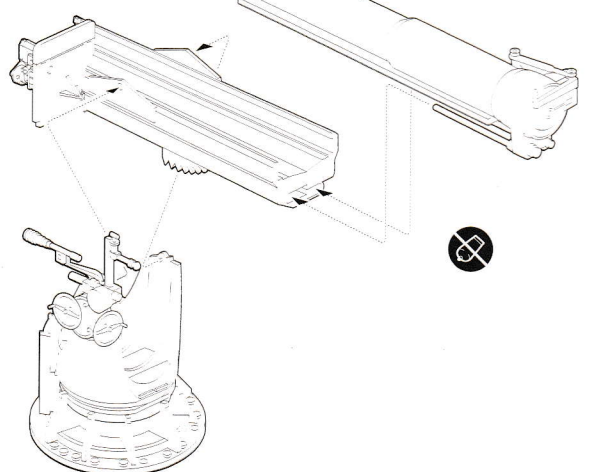
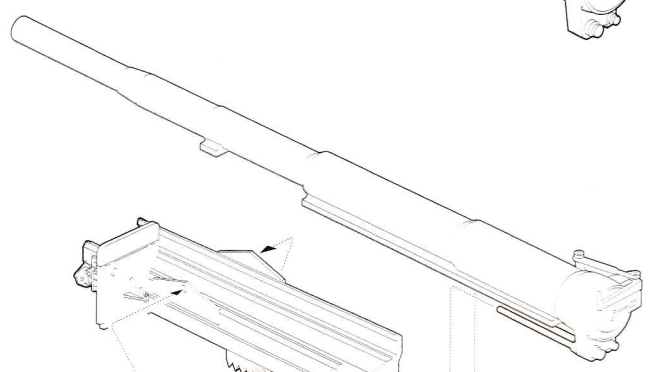
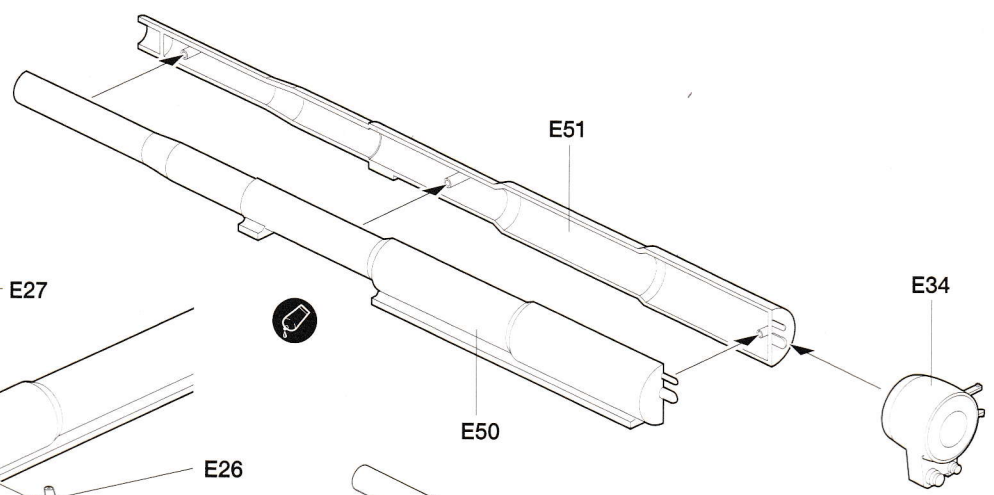
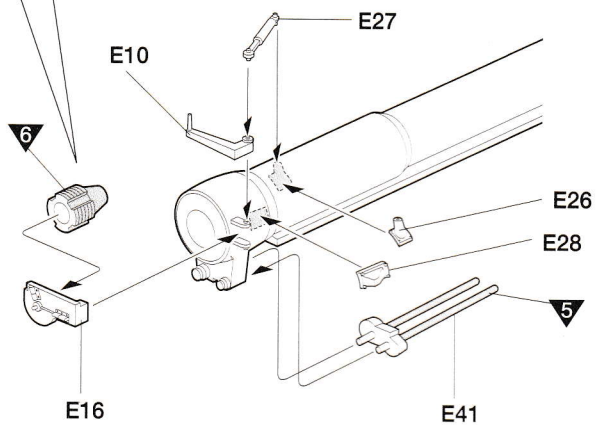
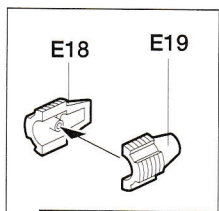

<Accessories アクセサリ- 악세서리>

4		
2		2

15

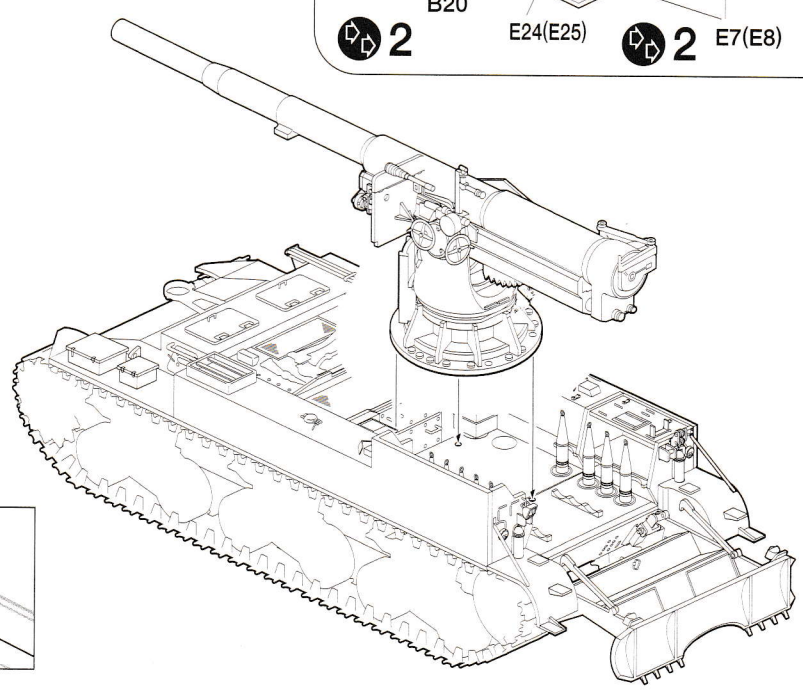
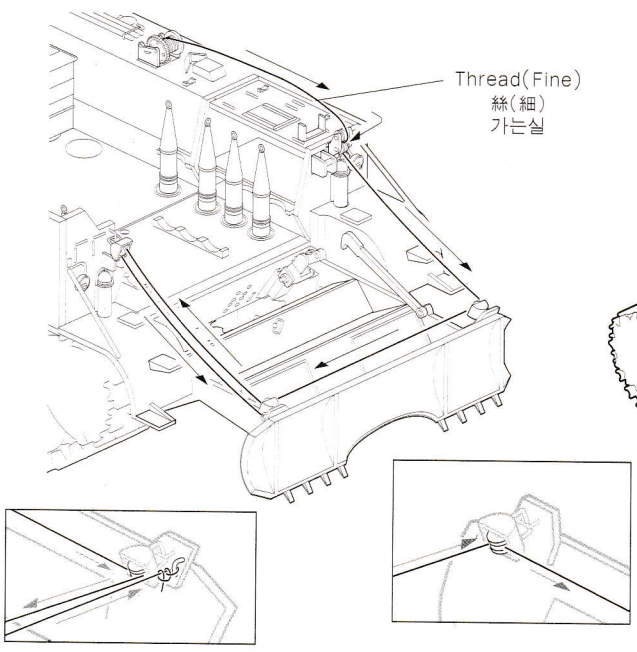

Painting & Decal placement 색칠 및 전사지 붙이기

1 St. Lo, France on July 1944 1947年 7月, フランス サン・ロ
1944년 7월 프랑스 생로

Body Color : **8**

車體色
차체색

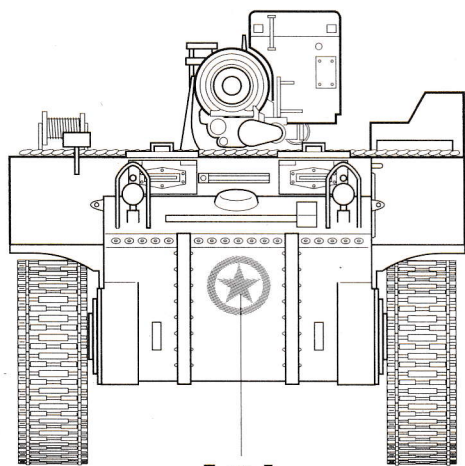

7 or 5

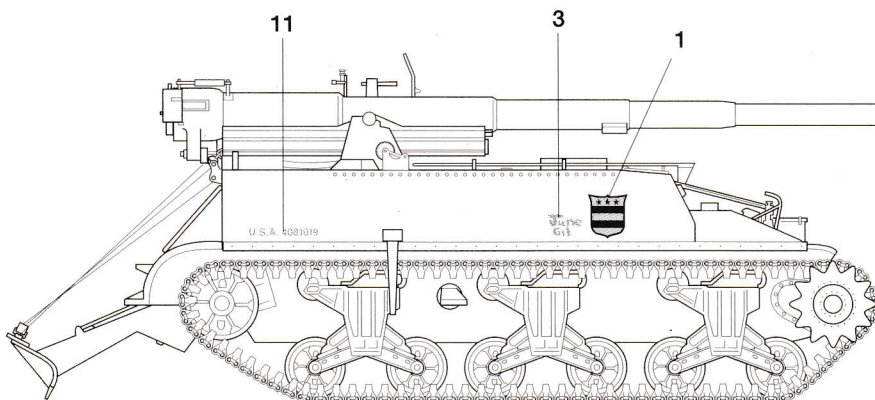
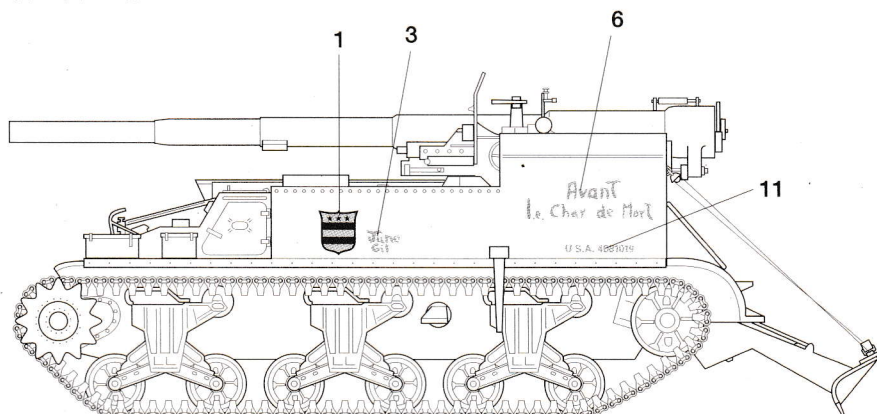

2 St. Lo, France on July 1944 1944年 7月, フランス サン・ロ
1944년 7월 프랑스 생로

Body Color : **8**

車體色
차체색

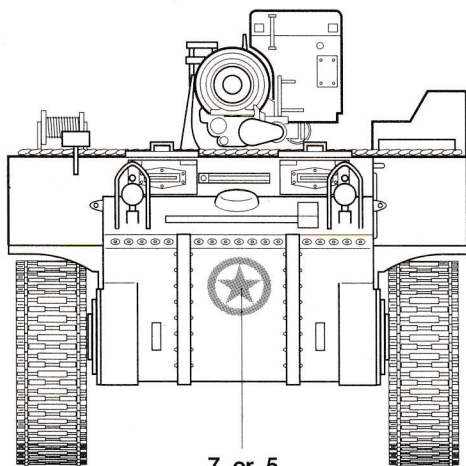

7 or 5

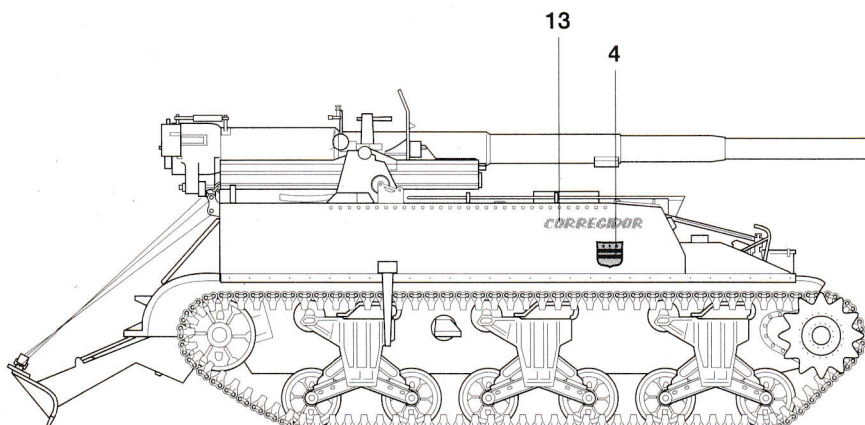
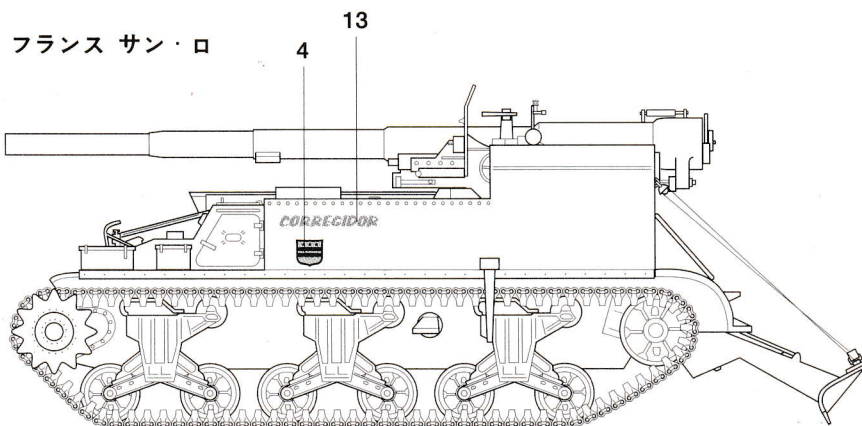

3 Kornelmunster, Germany on November 1944 1944年 11月, ドイツ コルネルミュンスター
1944년 11월 독일 코르넬문스터

Body Color : 8
車體色
차체색

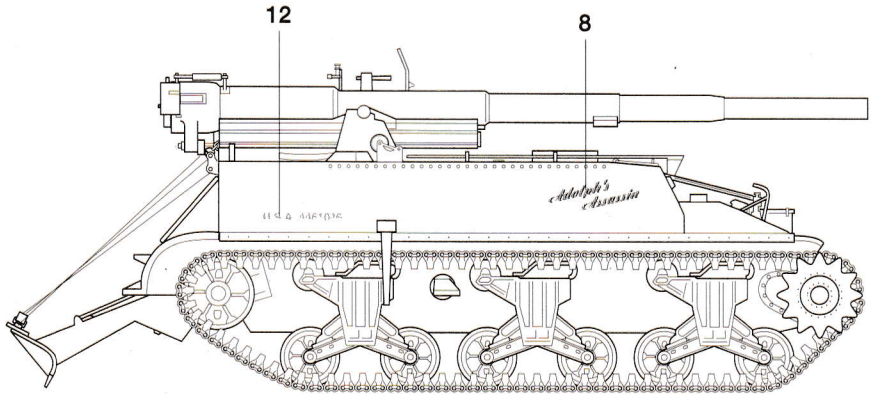
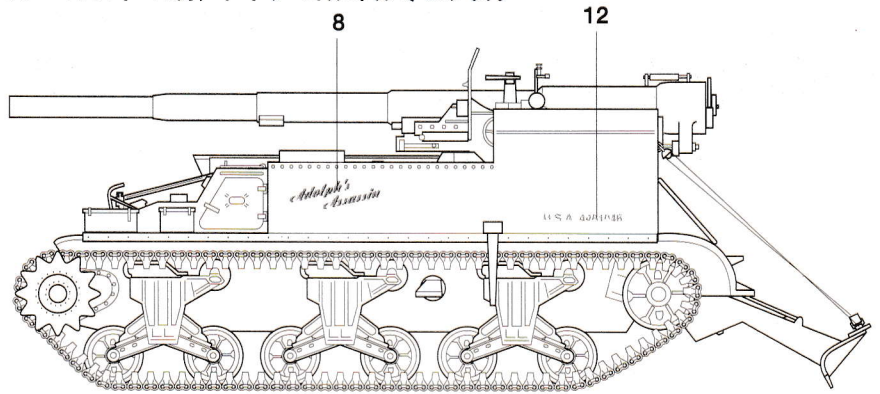
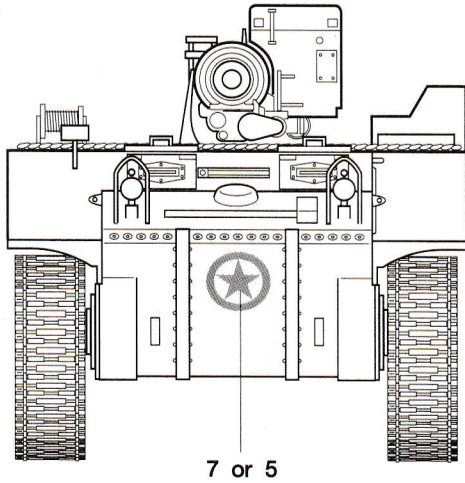

4 Budesheim, Germany on March 1945 1945年 3月, ドイツ ブ데スハイム
1945년 3월 독일 부데스하임

Body Color : 8
車體色
차체색

