



PLASTIC MODEL KIT

1/72

7222

✈ 548 mm ✈ 522 mm ✈ 549 mm

ENG

The Boeing P-8 Poseidon is an American maritime patrol and reconnaissance aircraft developed and produced by Boeing Defense, Space & Security, modified from the 737-800ERX. It was developed for the United States Navy (USN).

The P-8 operates in the anti-submarine warfare (ASW), anti-surface warfare (ASUW), and intelligence, surveillance and reconnaissance (ISR) roles. It is armed with torpedoes, Harpoon anti-ship missiles, and other weapons, can drop and monitor sonobuoys, and can operate in conjunction with other assets, including the Northrop Grumman MQ-4C Triton maritime surveillance unmanned aerial vehicle (UAV).

technical data

Length: **39.47 m** Span: **37.64 m** Height: **12.83 m**
Max take-off weight: **85 820 kg** Payload capacity: **23 100 kg**
Range: **8 300 km** Cruising speed: **815 km/h / 436 kn**
Ceiling: **12 500 m** Crew: **9 persons**

UKR

Boeing P-8 Poseidon – американський морський патрульний і розвідувальний літак, розроблений і вироблений Boeing Defence, Space & Security, модифікований на основі 737-800ERX. Він був розроблений для ВМС США (USN).

P-8 використовується для боротьби з підводними човнами (ASW), боротьби з надводною цілями (ASUW), а також для виявлення, спостереження та розвідки (ISR). Він озброєний торпедами, протикорабельними ракетами "Гарпун" та іншою зброєю, може скидати та контролювати гідроакустичні буї, а також може працювати разом з іншими засобами, включаючи морський безпілотний літальний апарат (БПЛА) Northrop Grumman MQ-4C Triton.

технічні характеристики

Довжина: **39,47 м** Розмах: **37,64 м** Висота: **12,83 м**
Максимальна злітна вага: **85 820 кг** Корисна вага: **23 100 кг**
Дальність: **8 300 км** Крейсерська швидкість: **815 км/год. / 436 вузлів**
Фактична стеля: **12 500 м** Екіпаж: **9 чол.**

assembly symbols / спеціальні умовні позначки для збирання



варіанти збирання використати «суперклеї» не клеїти зігнути деталь зібрати кілька просвердлити отвір симетричне збирання відрізати / прорізати

- White**
Білий
H1 1 **71.001**
- Flat Black**
Чорний Матовий
H12 33 **71.057**
- Light Grey** (FS 36495)
Світло-сірий
H338 338 **71.276**
- Grey** (FS 36270)
Сірий нейтральний
H306 306 **71.275**
- Grey** (FS 36118)
Сірий
H305 305 **71.097**
- Green** (FS 34227)
Зелений
H312 312 **71.126**
- Shin Silver / Chrome**
Сріблястий / Хром
H8 90 **77.707**
- Burnt Iron**
Палений метал
H76 61 **77.721**
- Steel**
Сталь
H18 28 **77.712**
- Tire Black**
Гума
H77 137 **71.315**
- Medium Gunship Gray**
Темно-сірий (FS 35048)
H5 375 **70.899**
- Clear Red**
Прозорий червоний
H90 47 **70.934**
- Red**
Яскраво-червоний
H3 3 **70.945**

AV HOBBY COLORS H304 304
AV vallejo COLORS **72.000**

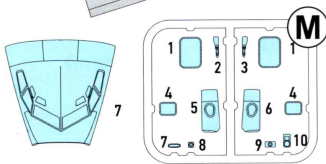
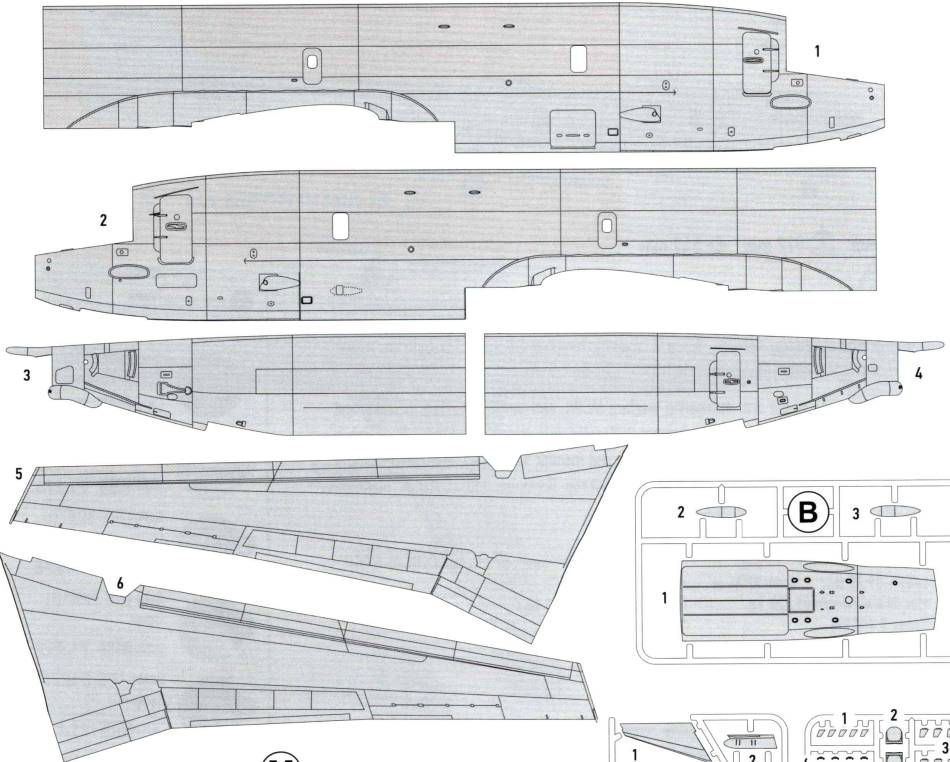

do not use / не використовувати

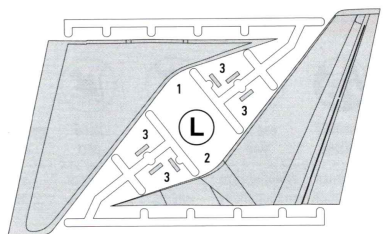
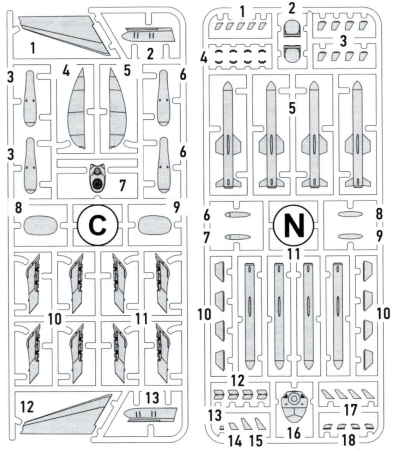
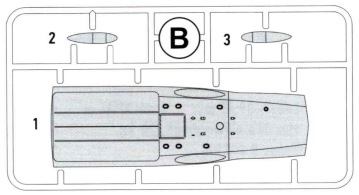
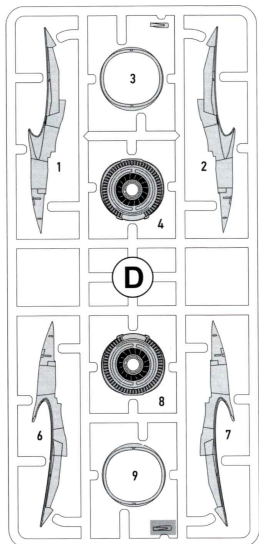
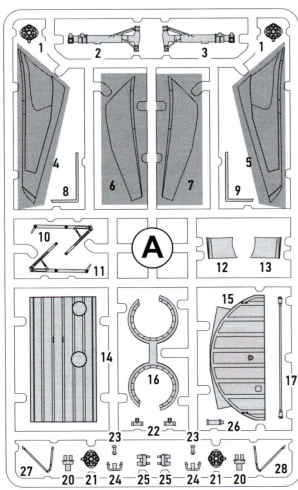

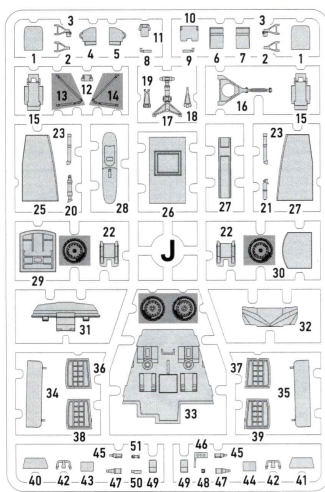
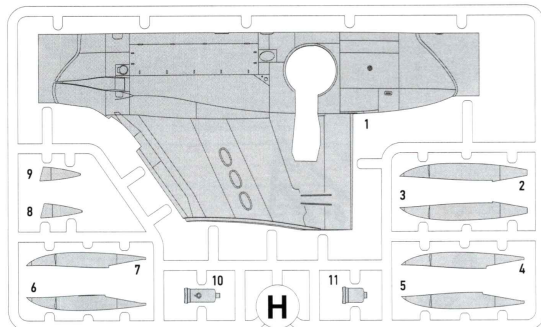
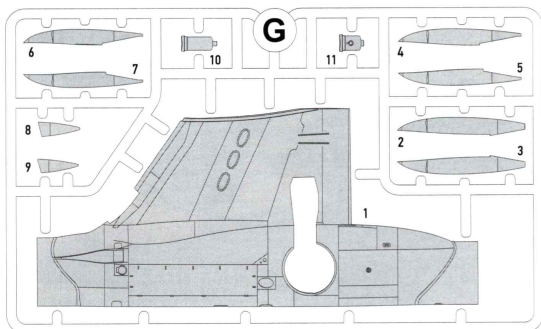
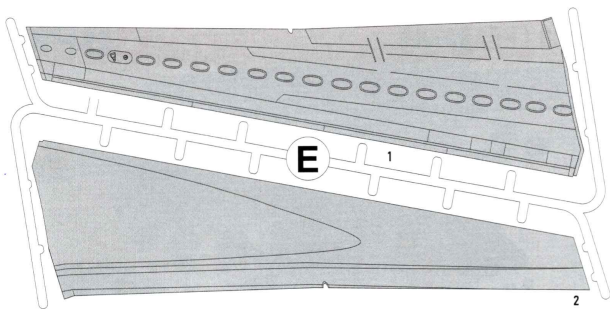
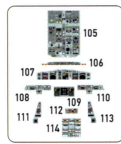
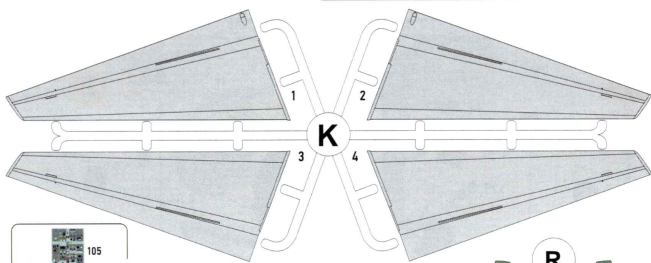
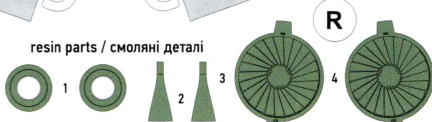
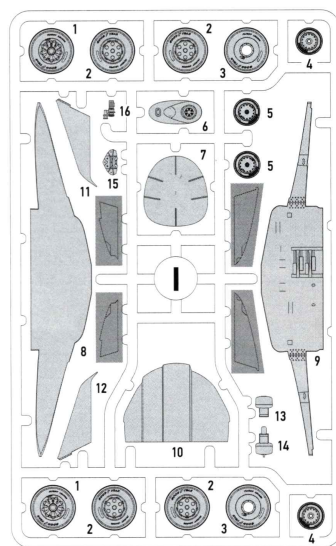
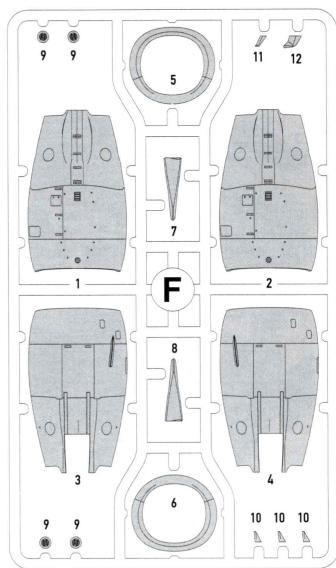
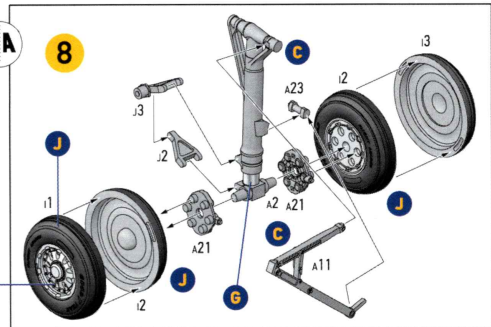
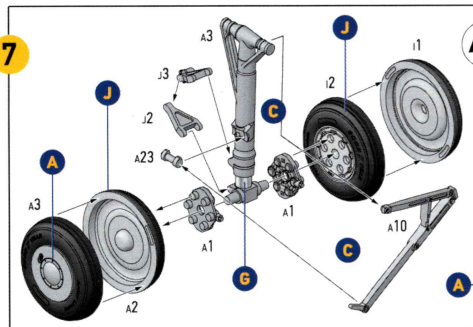
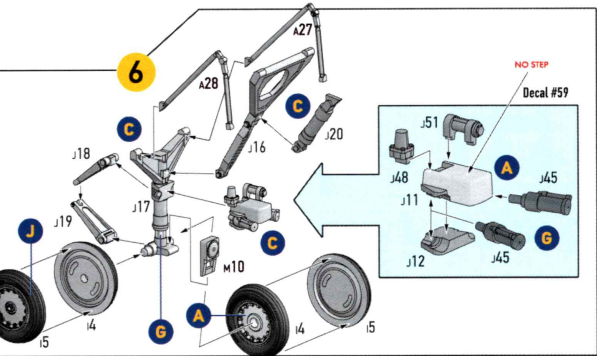
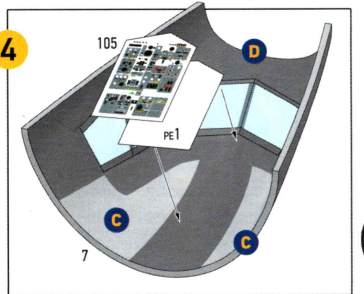
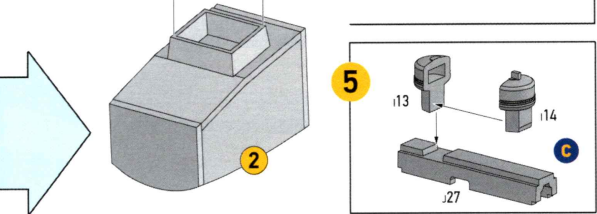
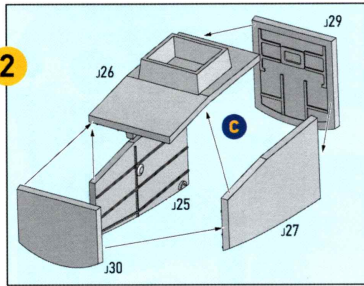
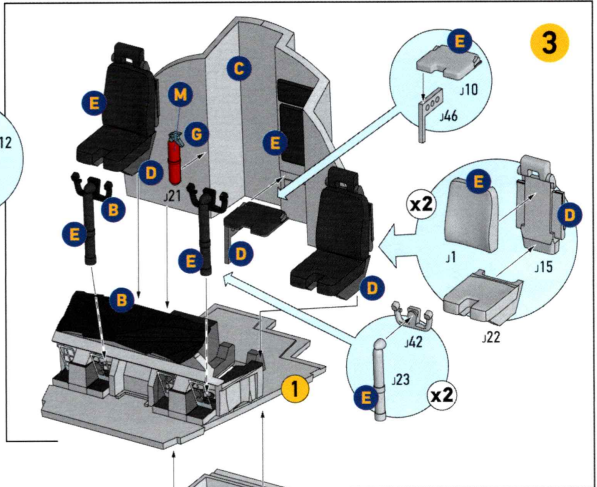
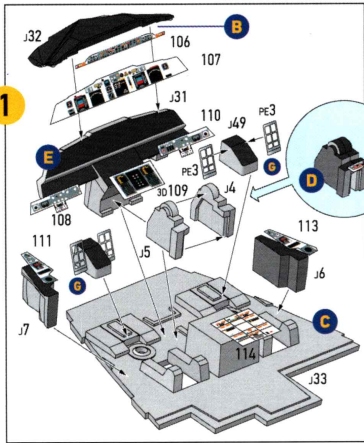

photo etched parts /
фототравлені деталі



do not use / не використовувати





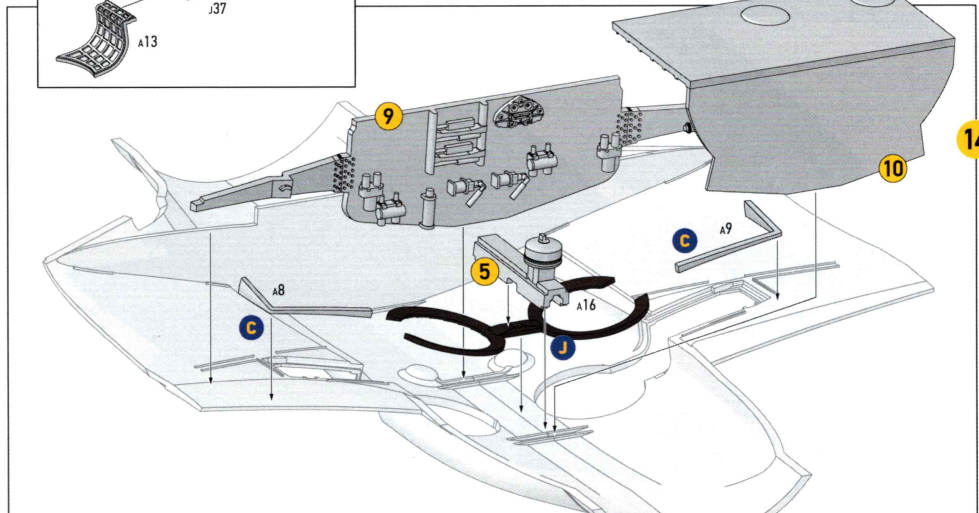
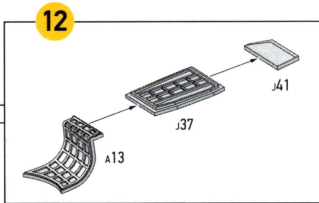
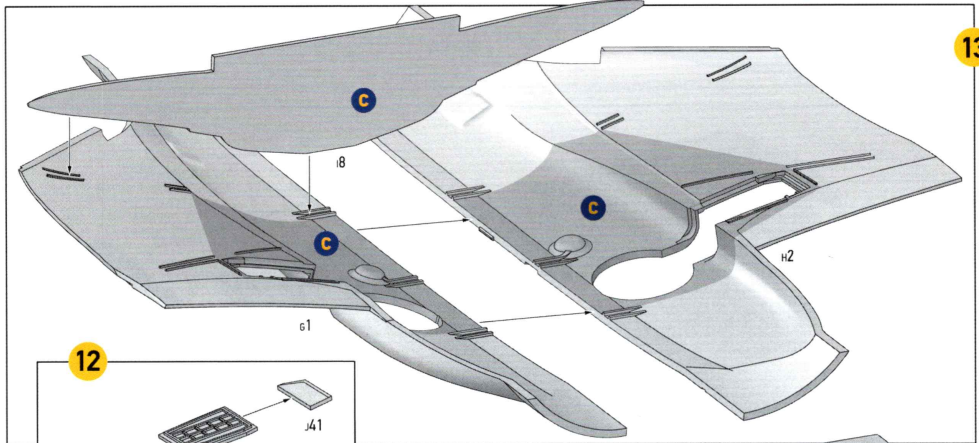
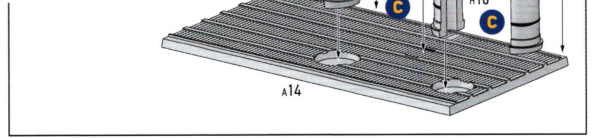
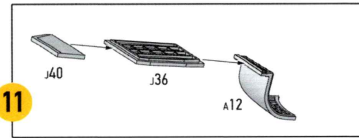
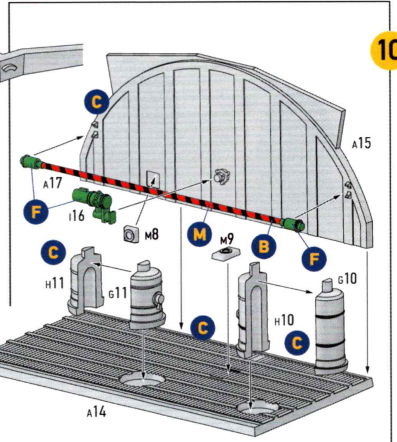
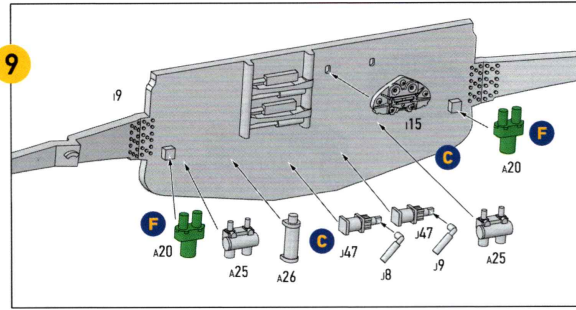

15

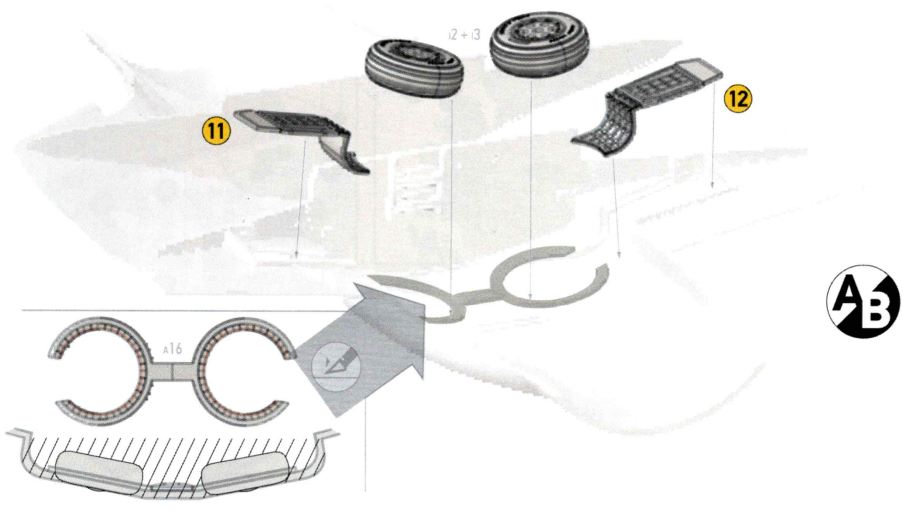

16

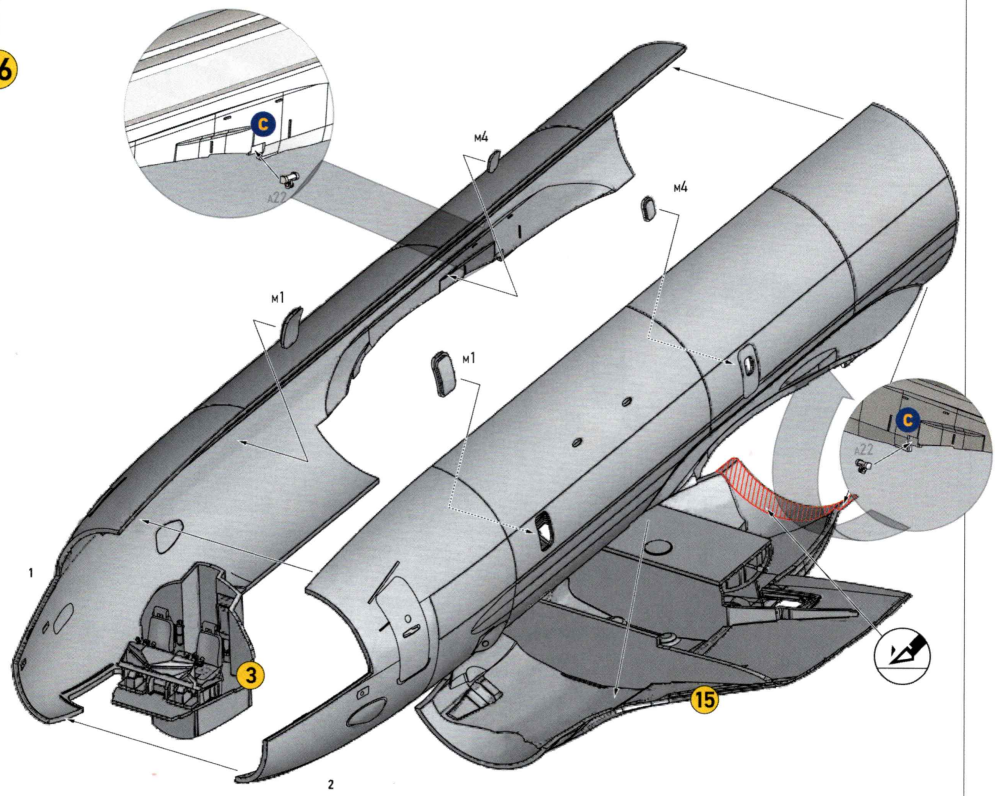

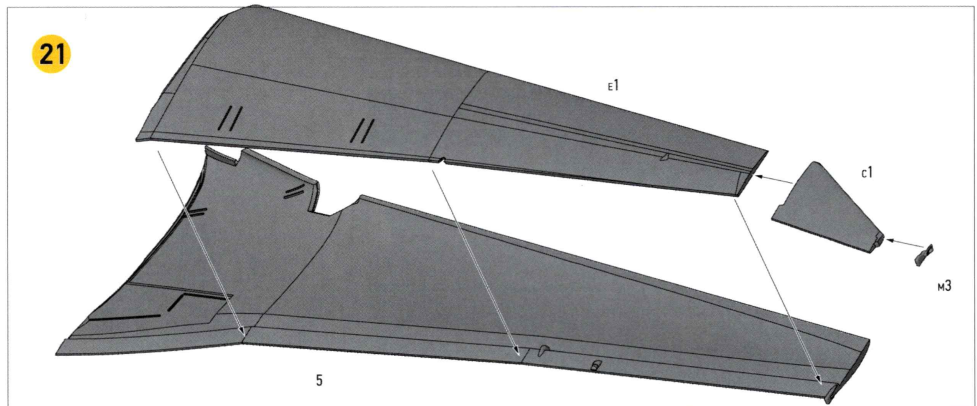
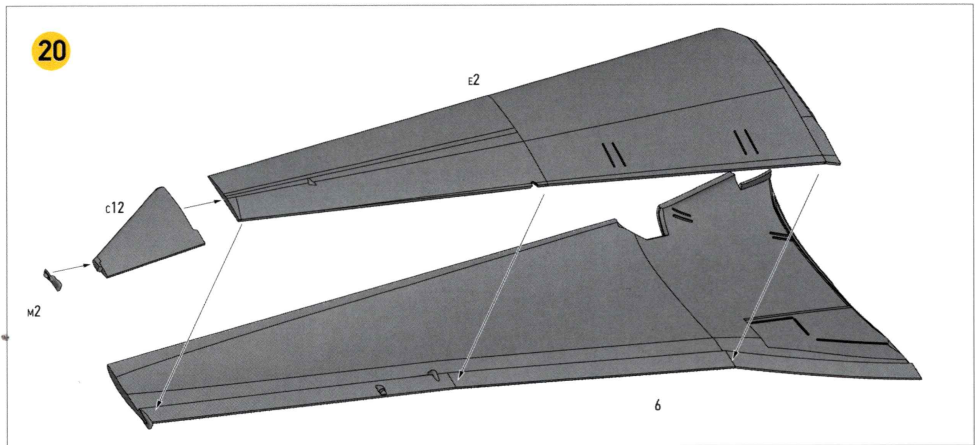
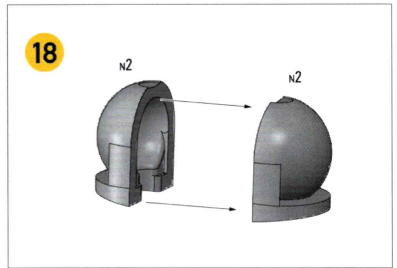
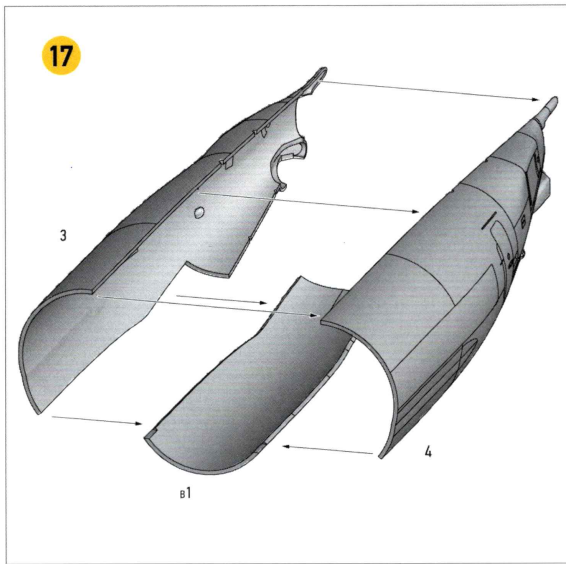

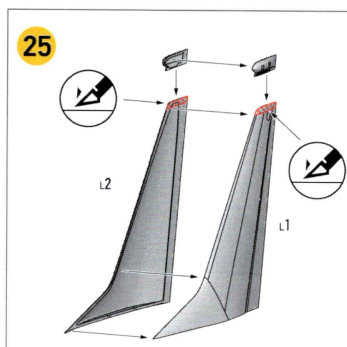
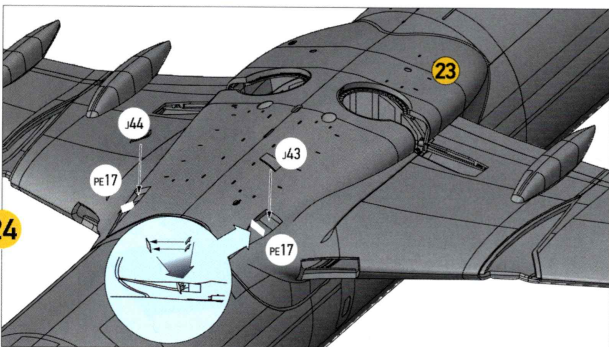
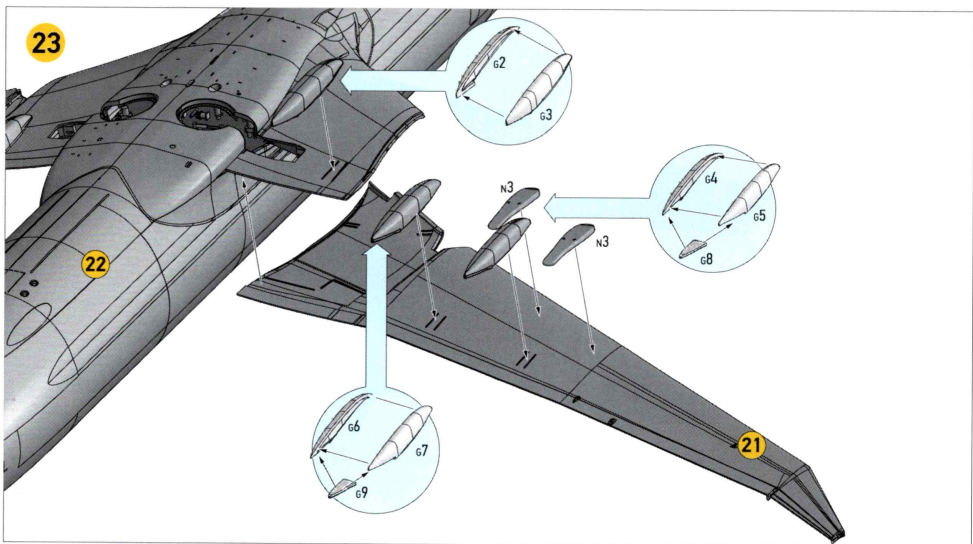
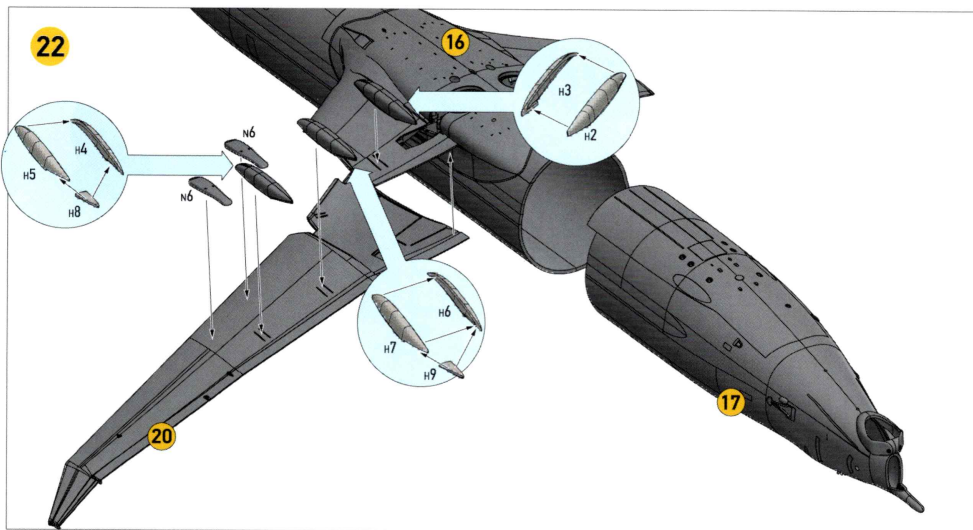

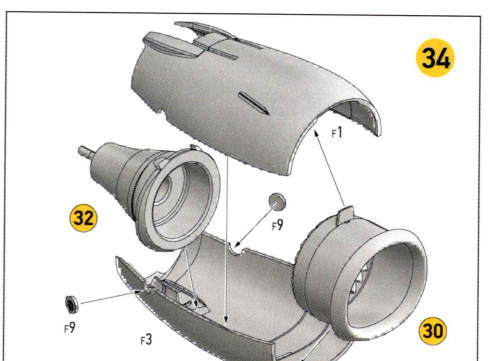
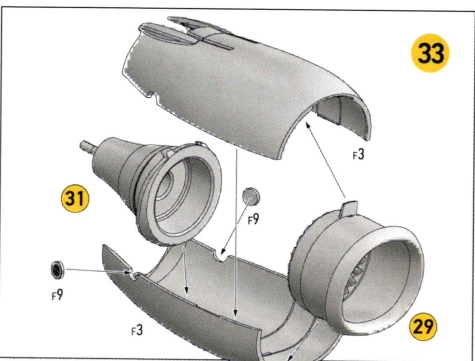
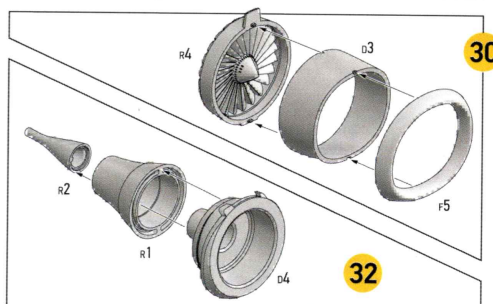
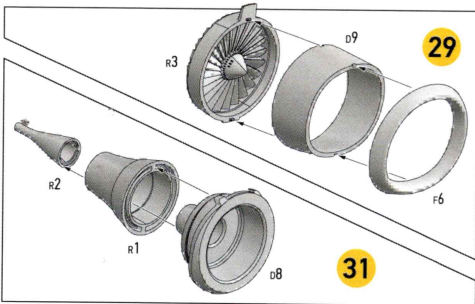
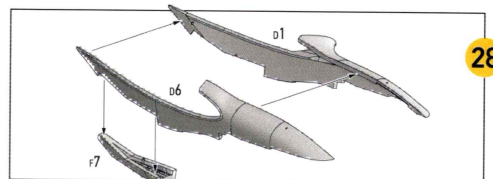
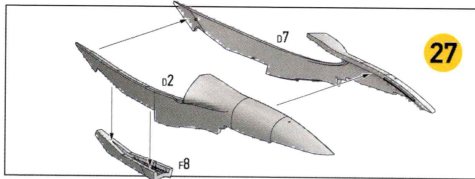
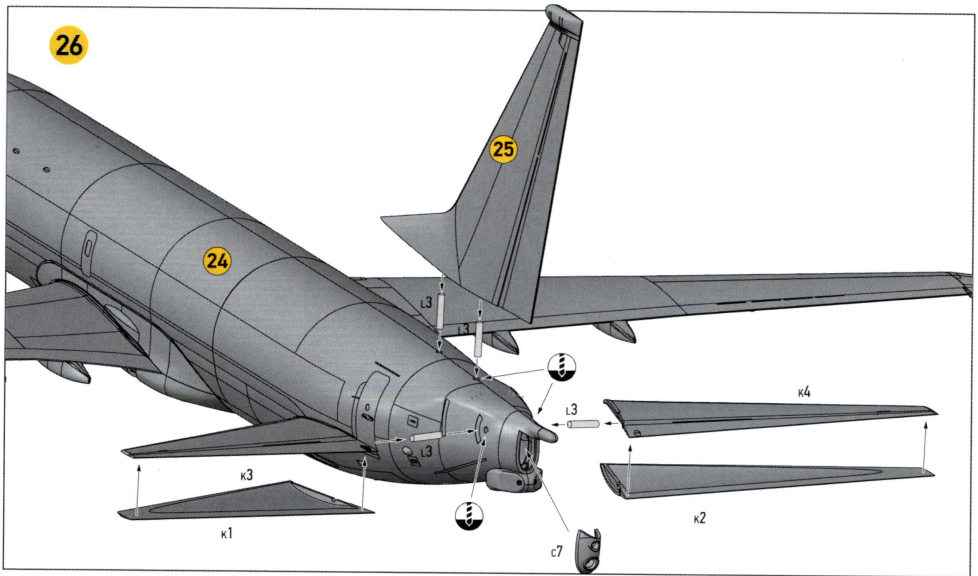

35

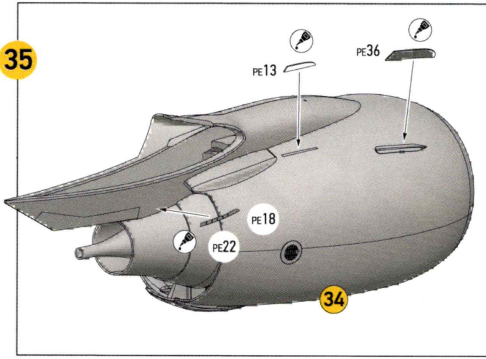

36

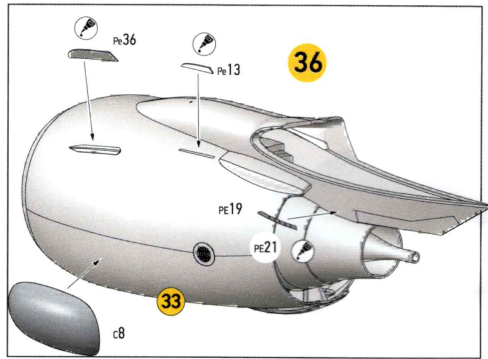

37

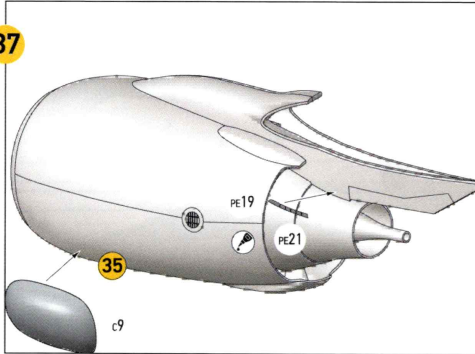

38

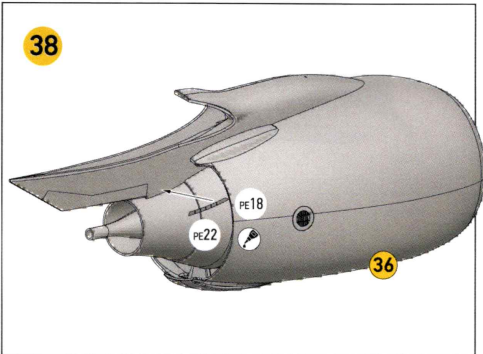

39

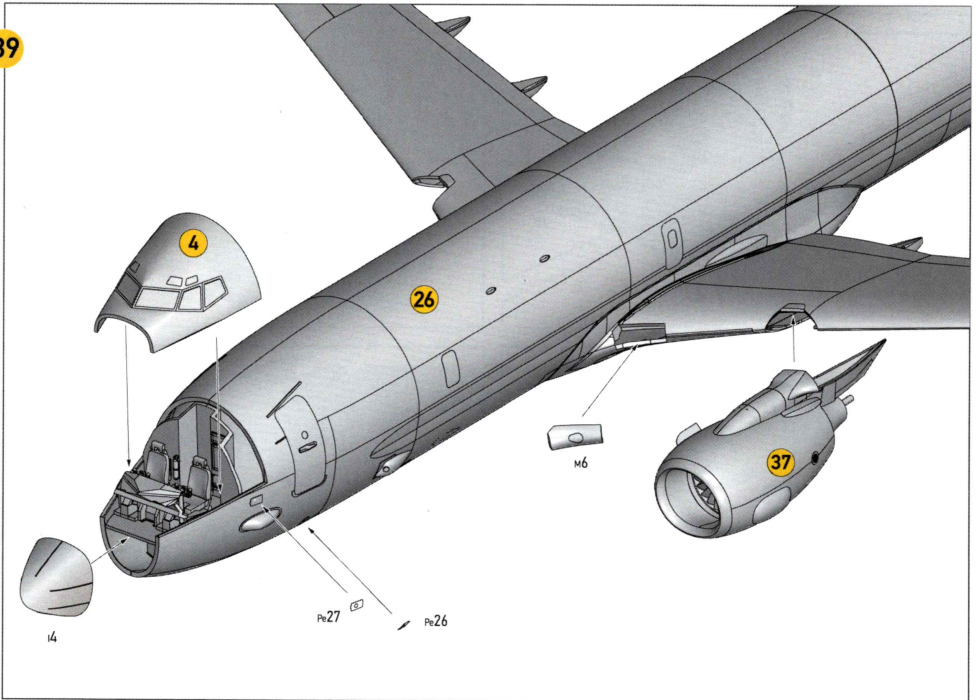

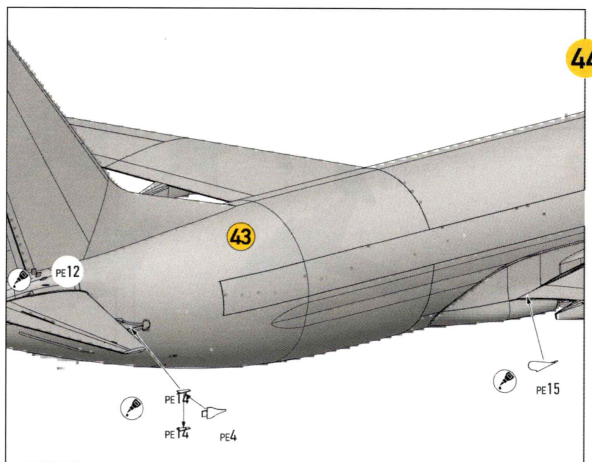
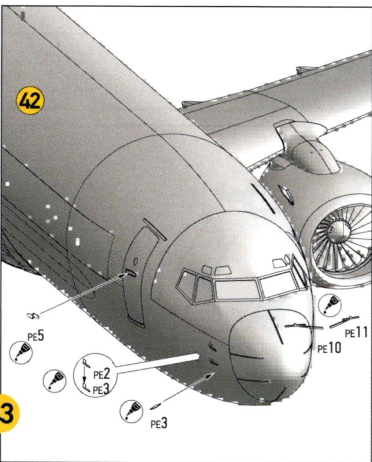
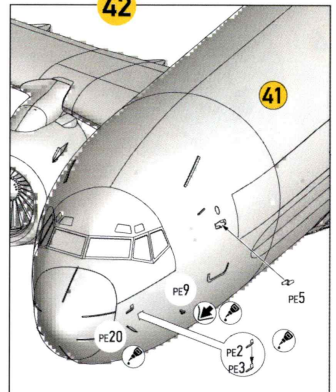
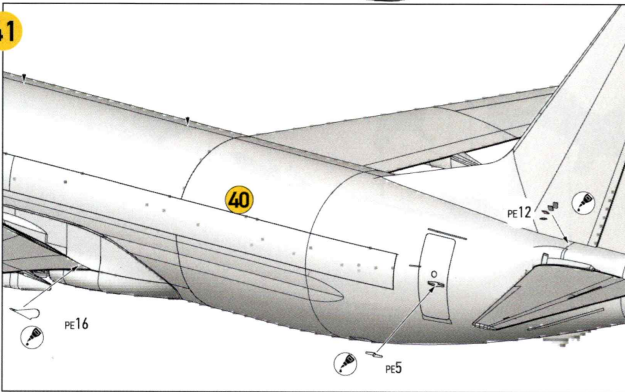
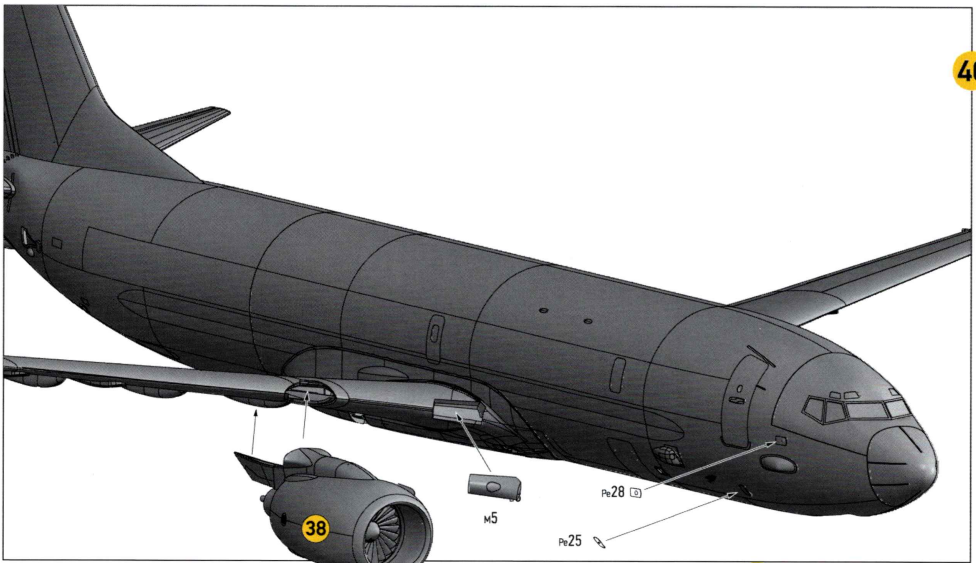

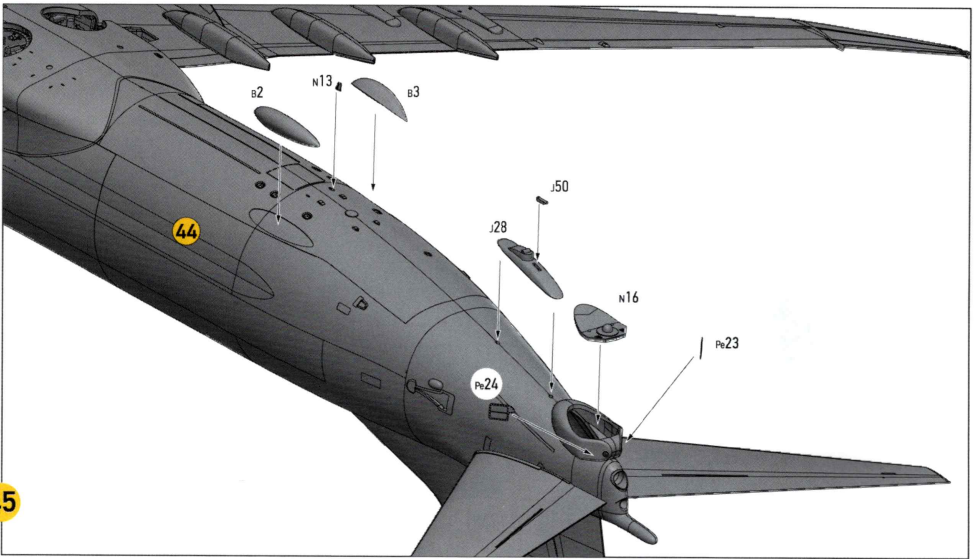

45

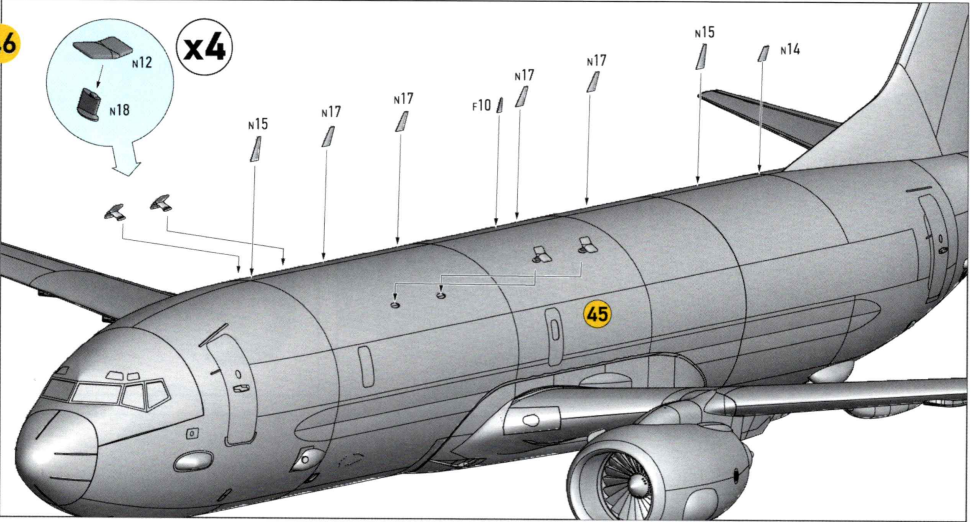

46

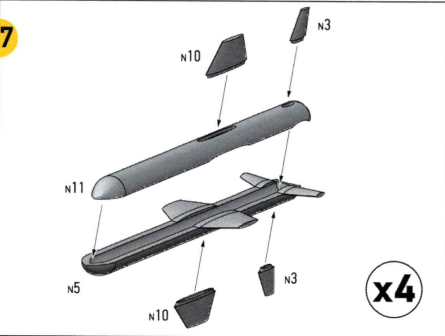

47

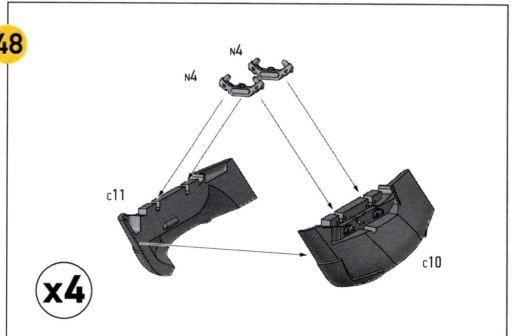

48

49

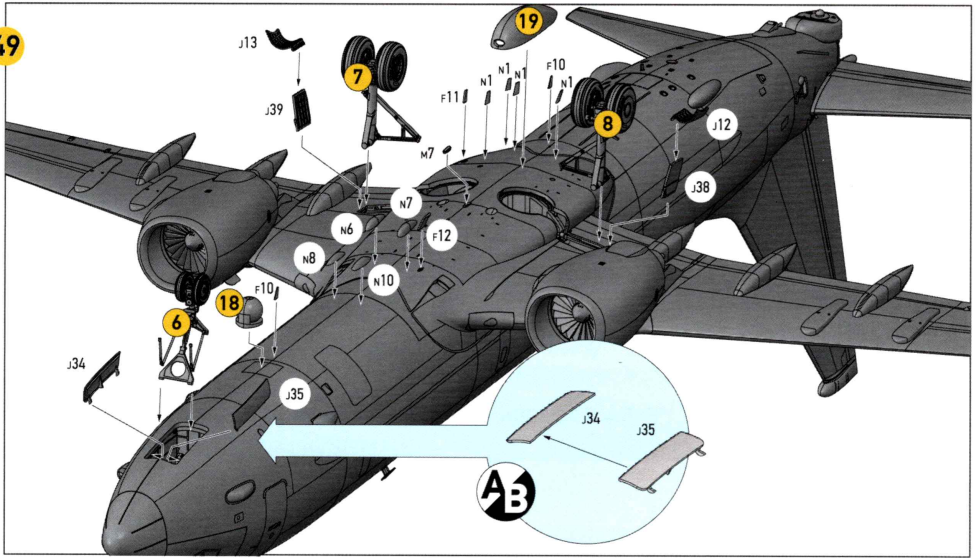

50

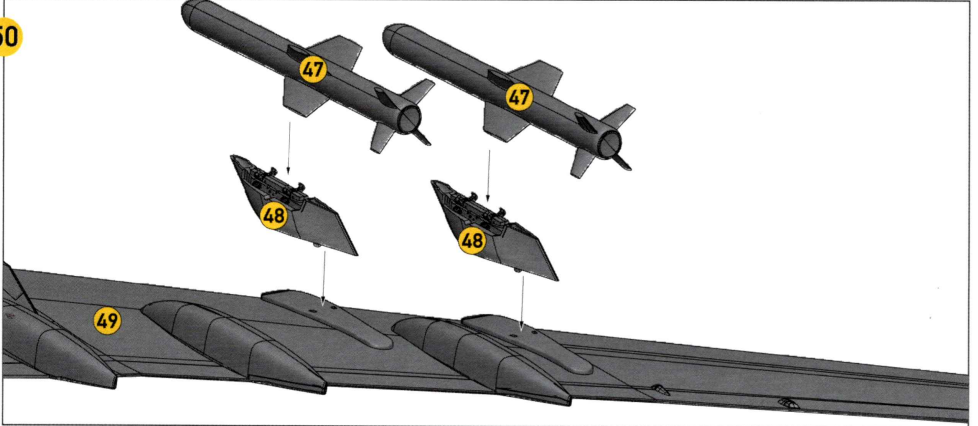

51

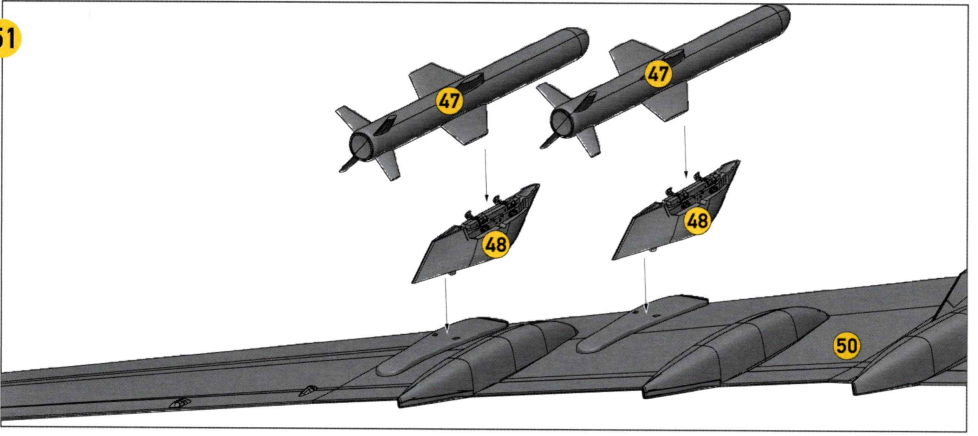

- A** White (FS 37875) / Білий (FS 37875) / арт. № 71.001
- B** Light Grey (FS 36495) / Світло-сірий (FS 36495) / арт. № 71.276
- C** Shine Silver / Chrome / Сріблястий / Хром / арт. № 77.707
- D** Burnt Iron / Палений метал / арт. № 77.721
- E** Tire Black / Гума / арт. № 77.315
- F** Steel / Сталь / арт. № 77.712
- G** Medium Gunship Gray / Серіо-сірий (FS 35142) / арт. № 70.899
- H** Red / Червоний (FS 35048) / арт. № 70.945

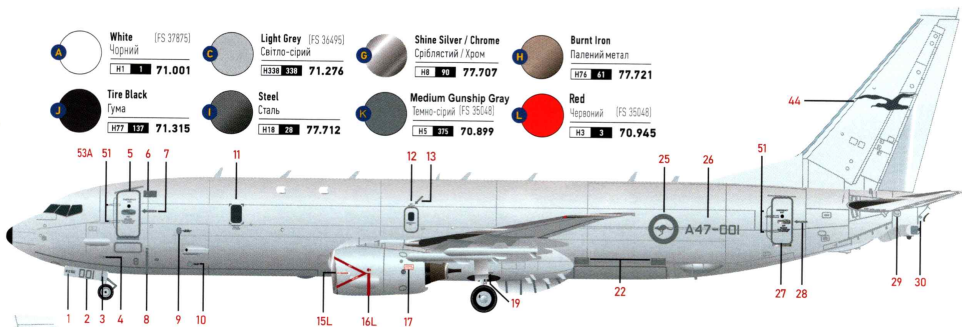

P-8A POSEIDON A47-001 ROYAL AUSTRALIAN AIRFORCE



decals / деколи

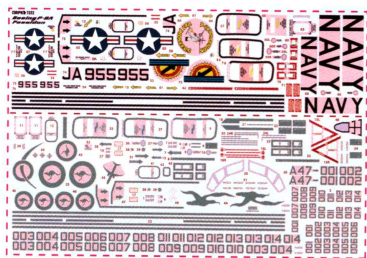

painting masks / маски для фарбування

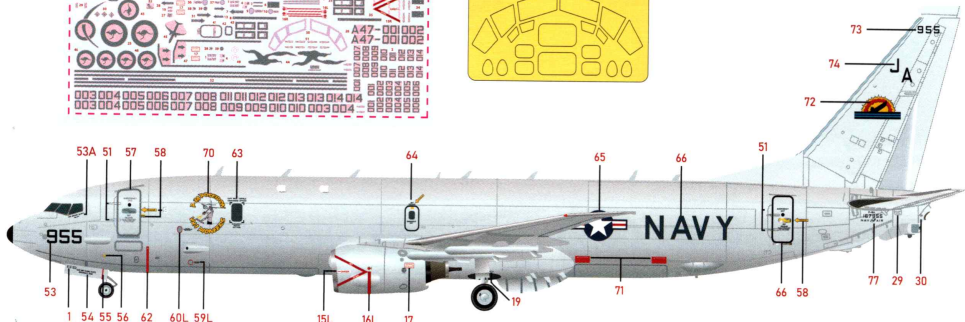
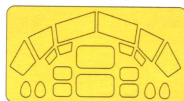

P-8A POSEIDON 167955, JA-955 VX-1 "PIONEERS"



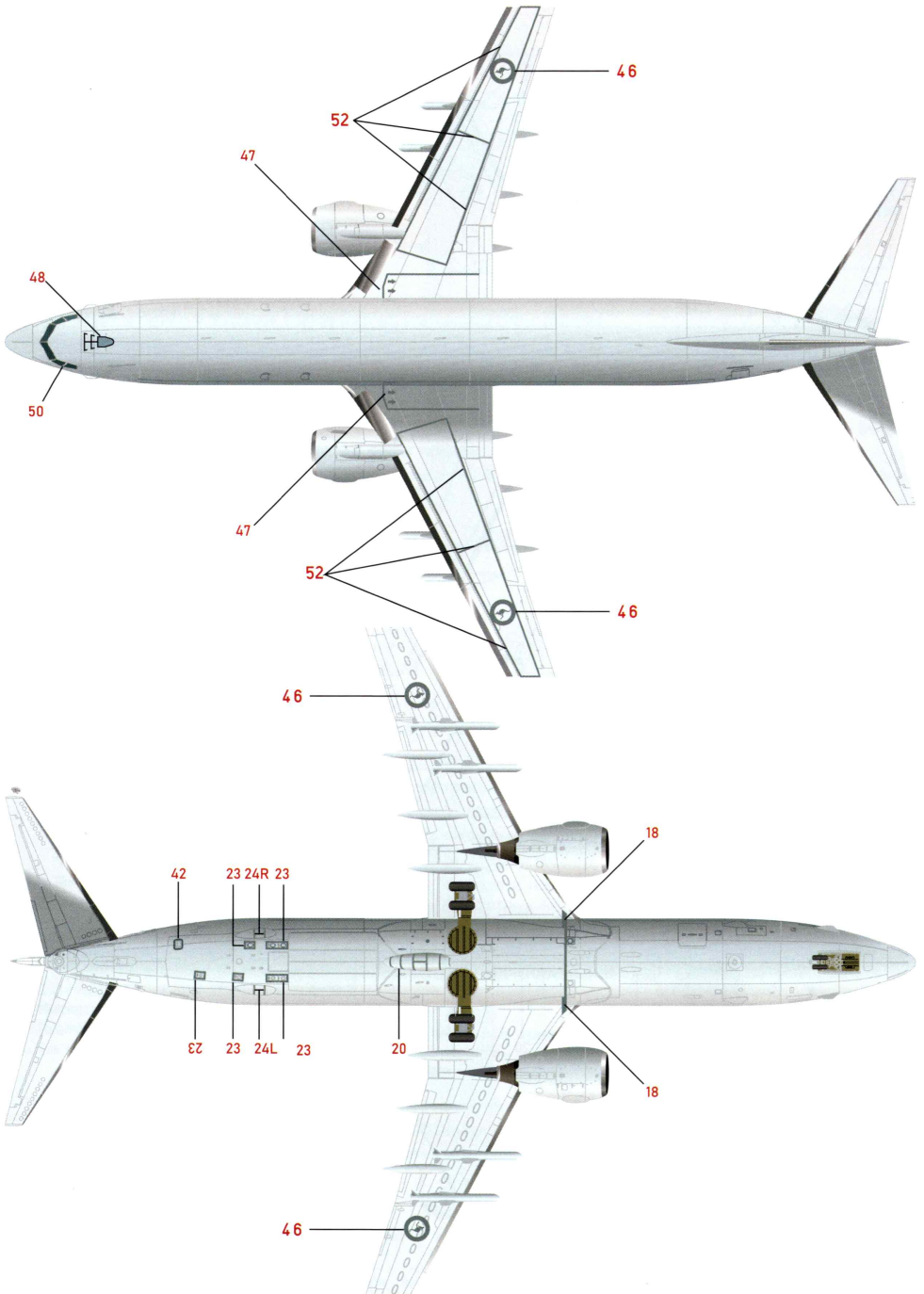

P-8A POSEIDON A47-001 ROYAL AUSTRALIAN AIRFORCE

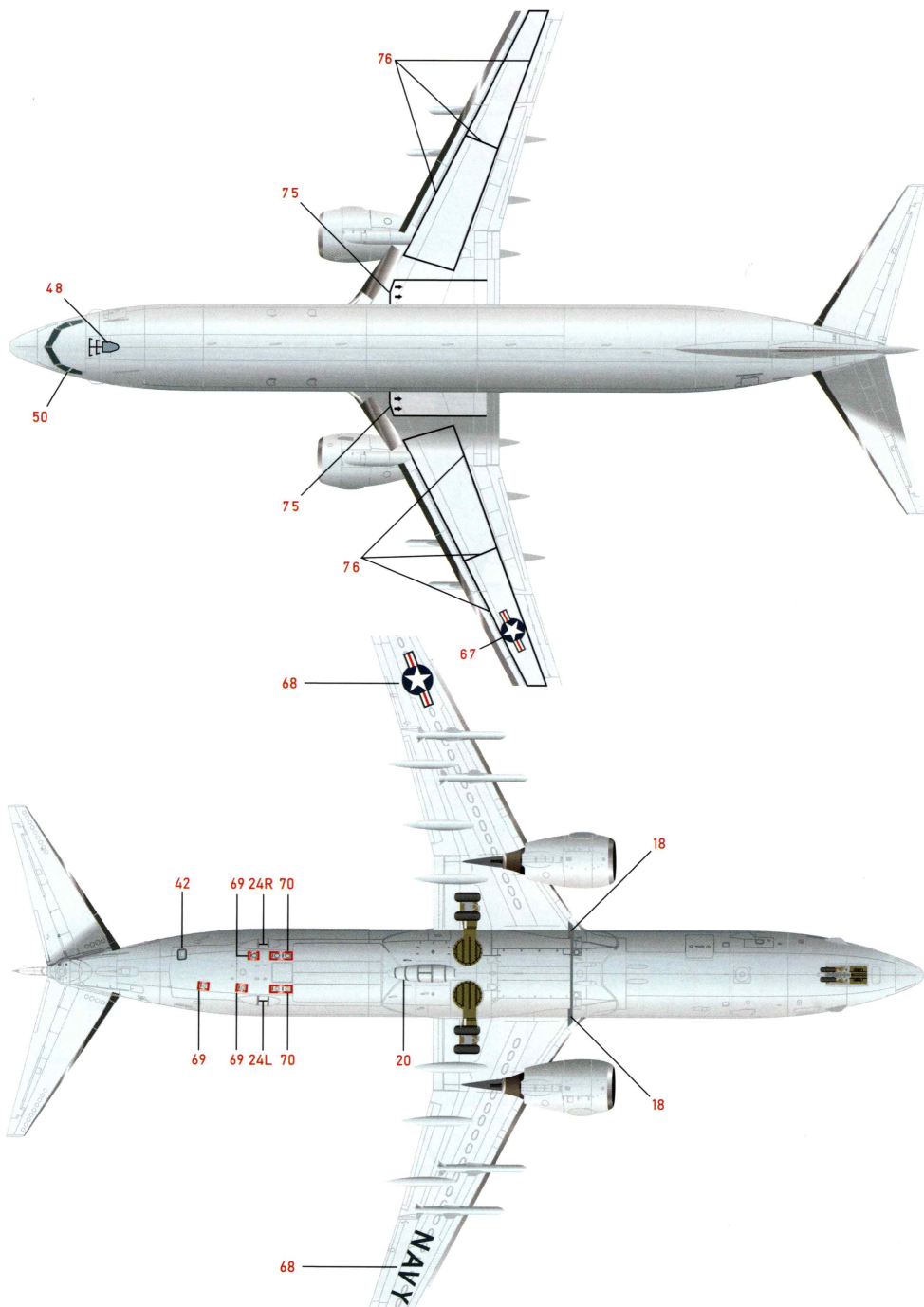

P-8A POSEIDON 167955, JA-955 VX-1 "PIONEERS"

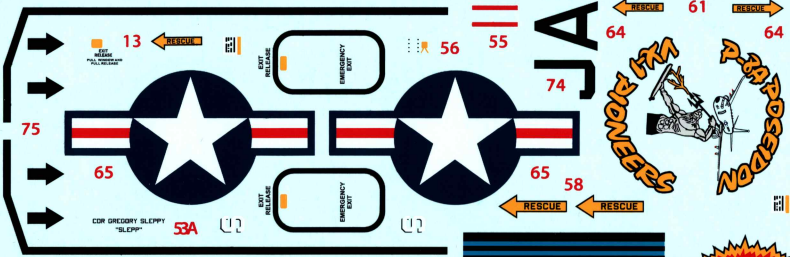

JA 955955

AMS (AW) CHRIS WHITE CINCINNATI, OH

955955

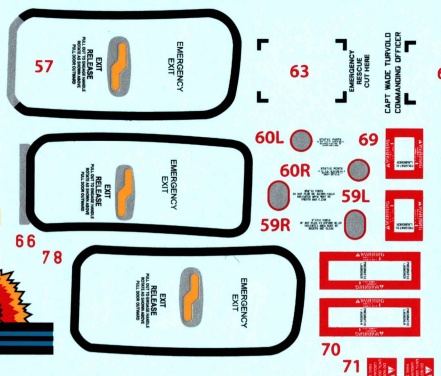

NAVY NAVY NAVY NAVY NAVY

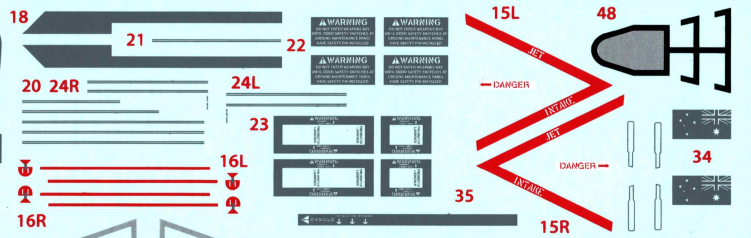
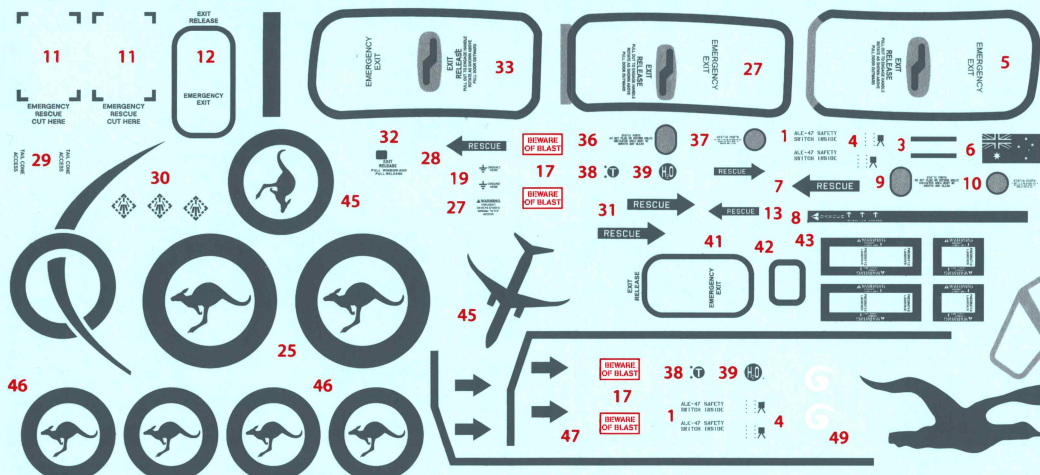
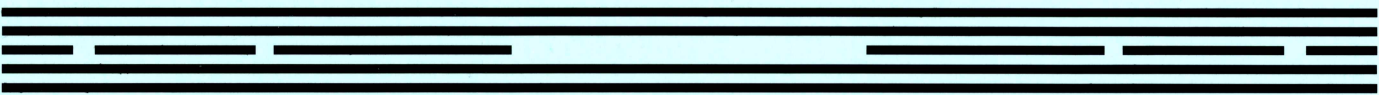

003004005006007008011011012012013013014014
003004005006007008009009010010003004

A47-001002
A47-001002
001007007
008008
009009
010010
011011
012012
013013
014014
001001
002002
003003
004004
005005
006006

