

# FROG F.201 HEINKEL He111 H-1/H-6

How to put your Frog model together / Méthode d'assemblage de votre modèle Frog / Wie stellt man Ihr Frogmodell zusammen / Come montare il vostro modello Frog

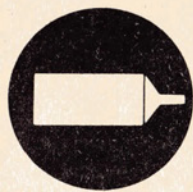

Cement parts together.  
Coller les pièces ensemble.  
Teile zusammenkleben.  
Cementeer de delen samen.  
Limma ihop delarna.  
Cementare le parti l'una con l'altra.  
Osat liimataan yhteen.



Do not cement together.  
Ne pas coller ensemble.  
Nicht zusammenkleben.  
Cementeer niet samen.  
Limma inte ihop delarna.  
Non cementare le parti.  
Osia ei liimata yhteen.



Shape with a hot knife.  
Former au canif chaud.  
Mit einem heißen Messer formen.  
Vorm met een heet mes.  
Forma med varm kniv.  
Modellare con la lama di un coltello, riscaldata.  
Muovetkaa kuumella veitsellä.



Choice of parts provided.  
Choix de pièces fournies.  
Mittelleierte Auswahl an Teilen.  
Keuze van beschikbare onderdelen.  
Dessa delar medföljer för val.  
Particolari a scelta.  
Osien käyttö valinnanvaraisesti.

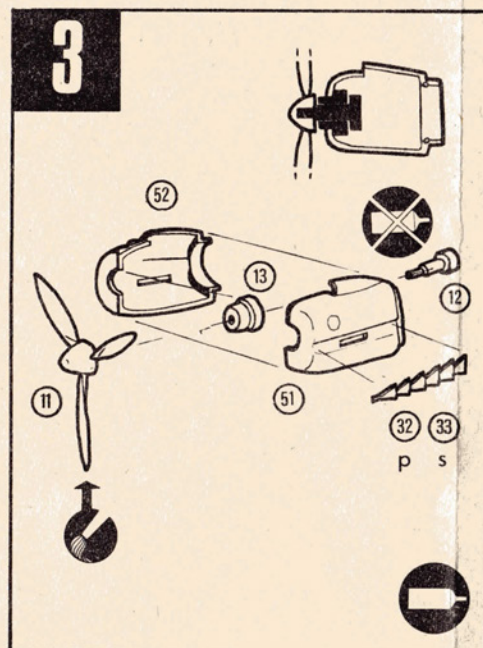
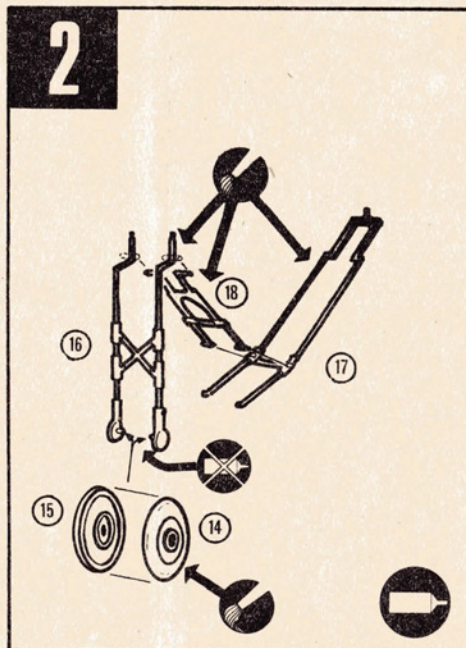
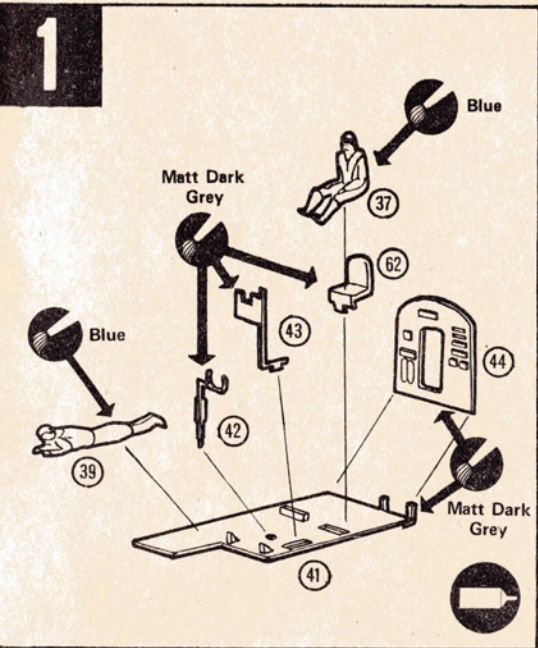



Montare il modello Frog /Hoe zet ik mijn Frogmodel in elkaar/Hur man sätter ihop Frog-modellen/Kootkaa Frog mallinne näin.



Paint parts before using.  
 Peindre les pièces avant l'emploi.  
 Die Teile sollen vor Benutzung bemalt werden.  
 De onderdelen voor het gebruik schilderen.  
 Mäla delarna före användningen.  
 Varniciare le parti prima di montarle.  
 Maalattaa osat ennen kokoamista.



Cut with a sharp knife.  
 Couper avec un couteau tranchant.  
 Mit einem scharfen messe schneiden.  
 Snijd met een scharp mes.  
 Skär med en skarp kniv.  
 Tagliare con un coltello affilato.  
 Leikatkaa terävällä veitsellä.



Insert small weight  
 Introduire le petit contrepoids.  
 Das kleine Gewicht soll eingesteckt werden.  
 Een klein gewichtje invoegen.  
 Stick in en liten tyngd.  
 Introdurre il piccolo peso  
 Laittkää pieni paino.

4

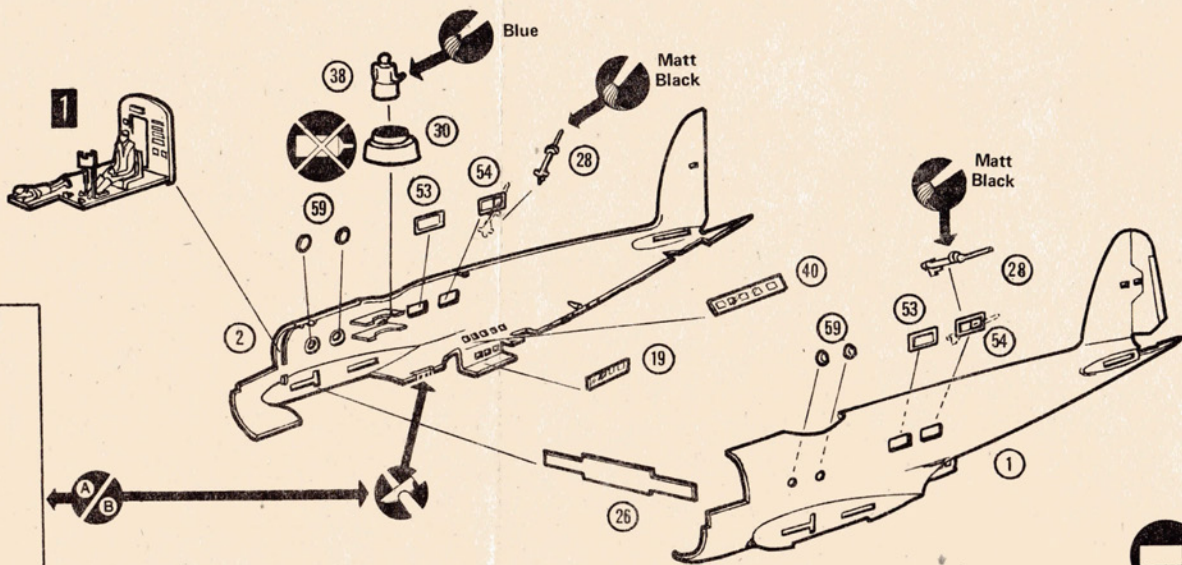

5

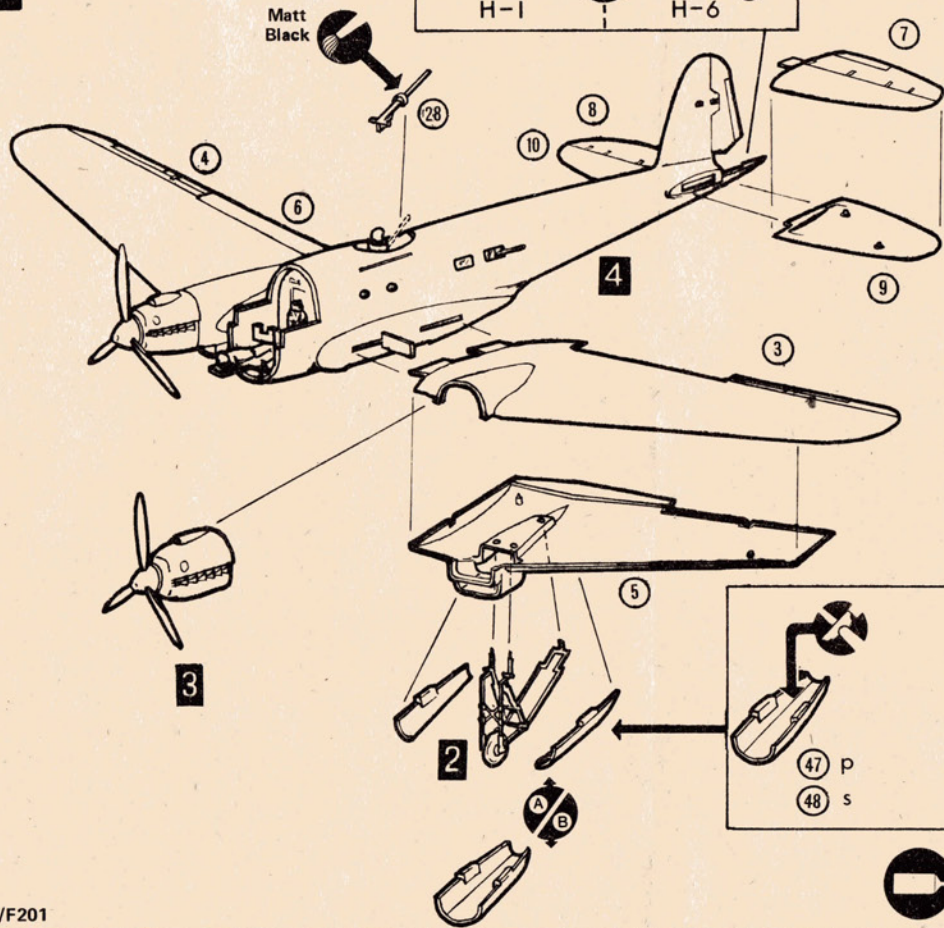

6

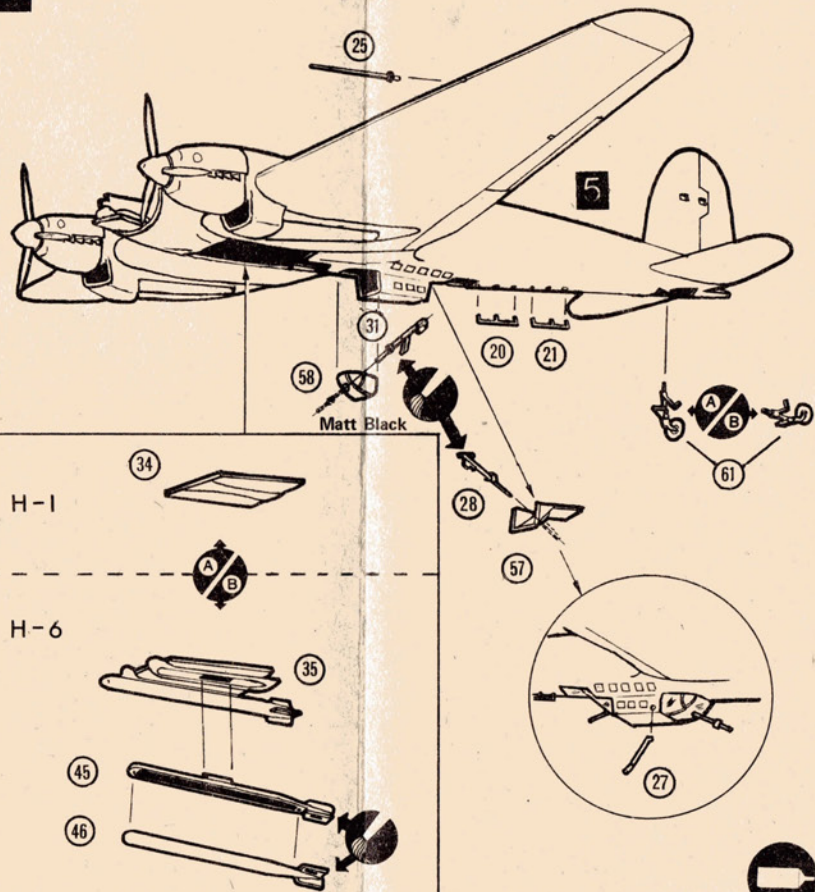



# 7

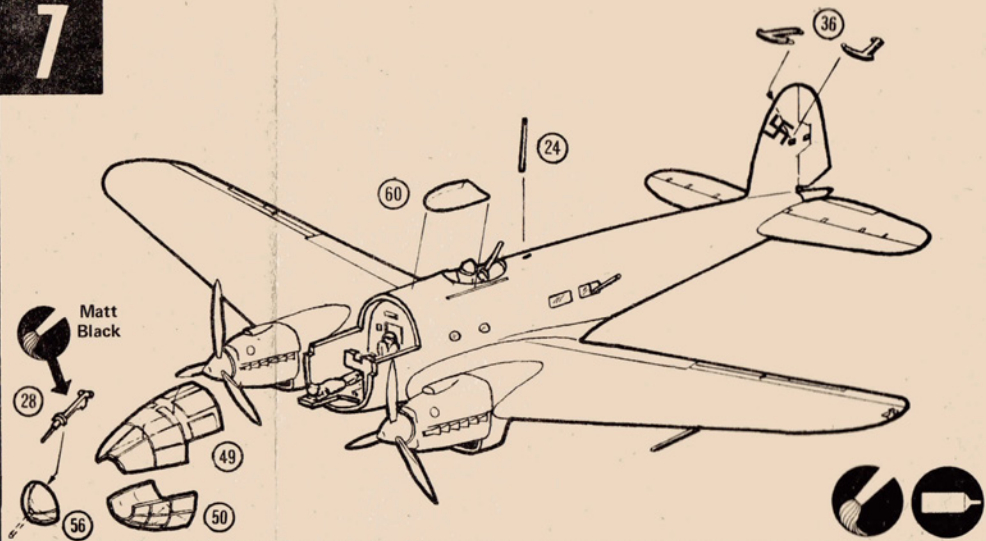

Every precaution has been taken to ensure that your kit will reach you complete. If however you find any part is faulty or missing please fill in the details opposite in block letters and return the slip to :

Rovex Triang Limited,  
Service Department,  
Westwood, Margate,  
Kent, England.

Please give the Number of the Part shown in the exploded assembly diagram in this instruction leaflet.

Name and Number of Kit.....

No. of Part.....

**PLEASE USE BLOCK LETTERS**

Name .....

Address .....