

## Russian Obj199 BMPT Ramka w ATGM launcher "ATAKA"

### 俄罗斯BMPT火力支援战车“阿塔卡”

#### READ BEFORE ASSEMBLY:

- Study and understand these instructions thoroughly before beginning assembly
- When needed, remove photo-etch parts carefully using a modeling knife or photo etch sprue cutter, being careful not to damage or lose small parts.
- Take extra care in handling photo etch parts in order to avoid injury
- Apply instant cement sparingly to photo etch parts where instructed
- Tools recommended(not included in kit):Plastic and instant cements, sprue cutters,long nose pliers,modeling knife, small files, tweezers, pin vise & scissors. Soft cloth and sandpaper will also assist in construction
- Glue and paint are not included in the kit. Use plastic cement and hobby paints only. Color guide for purchasing paint is included in the kit.

#### 装配之前仔细阅读

- 小心用模型锉刀锉平所有零件表面的注射浇口。
- 小心用刀片切下蚀刻片零件，不要遗失小零件。
- 用强力快干胶水粘合蚀刻片零件和金属轴。过量快干胶水使用可能导致可动零件会粘住，小心涂胶。
- 取蚀刻片时应特别注意安全，防止利刃划伤手指。
- 某些零件表面需贴水上贴纸，请选择在装配的同时进行。
- 推荐模型工具(自备)：胶水，水口剪刀，长咀钳，刀片，锉刀，镊子，钳，钻，剪刀，瞬间快干胶。
- 软布同砂纸同时也应该是必备工具。
- 请使用塑料胶水和油漆，模型内不含。



配置  
Weight



使用强力胶  
Cyanoacrylate glue



钻孔  
Make hole



切除  
Cut / Remove



贴纸  
Decal



锉平  
File / Sand



选择  
Option



不涂胶水  
No cement



弯曲  
Bend



先装  
Install it first

#### 水贴纸的使用:

- 1.从水贴纸上剪下印花;
- 2.将印花放入温水中浸10秒,然后放在干净布上。
- 3.拿着印花纸板将印花移到模型上;
- 4.手指蘸水将印花移到适当的位置;
- 5.用软布轻压印花直至水干,汽泡消失

#### DECAL APPLICATION

- 1.Cut decals from sheet as needed
- 2.Dip the decal in warm water for about 10 seconds and then place on soft clean cloth.
- 3.Hold the decal backing sheet edge and gently slide the decal onto the model in its proper position.
- 4.While still wet,decal can be adjusted for better fit on model by dampening it gently with your finger.
- 5.When placed in the proper position,gently press decal down with a soft cloth until excess water and air bubbles are gone.
- 6.Allow decal to dry completely before handling model

Ax4

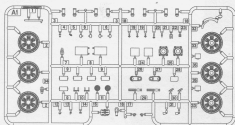

Bx2

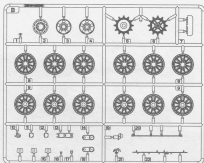

《车底》  
Lower hull



C

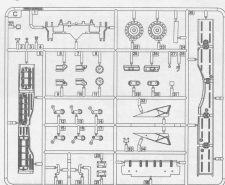

Dx2

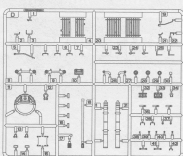

《车面》  
Upper hull

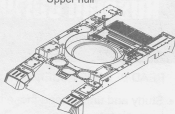

E

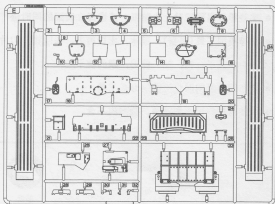

F

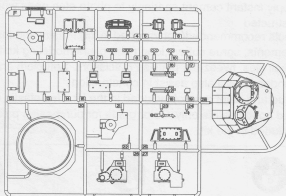

G

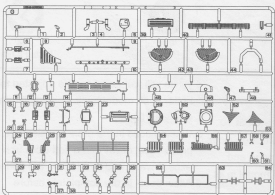

H

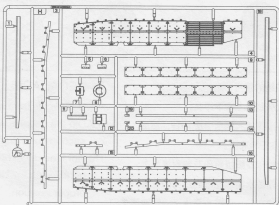

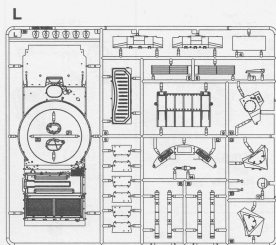
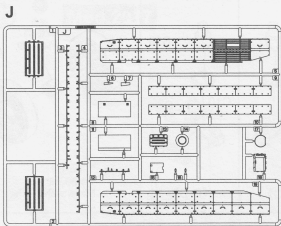

**TRx4**

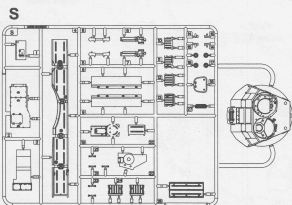
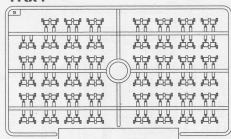

**Tx4**

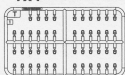

**GP**



《轮塞》  
Poly cap

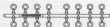

《铜线》  
Brass wire



**K**

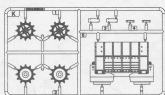

《蚀刻片A》  
PE-A

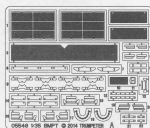

《蚀刻片B》  
PE-B

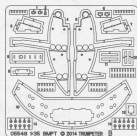

《蚀刻片C》  
PE-C



《蚀刻片D》  
PE-D



《水贴纸》  
Decal



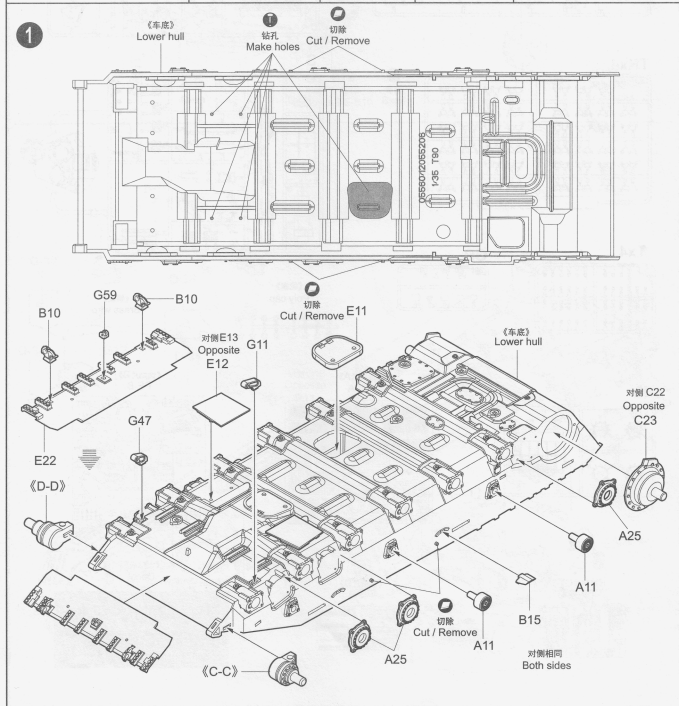
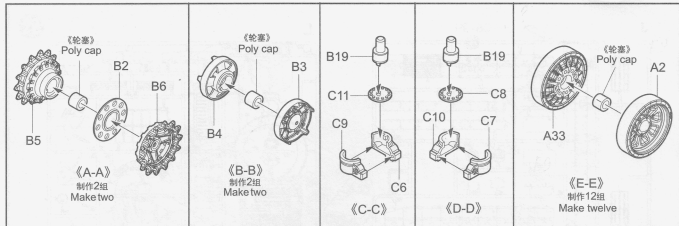

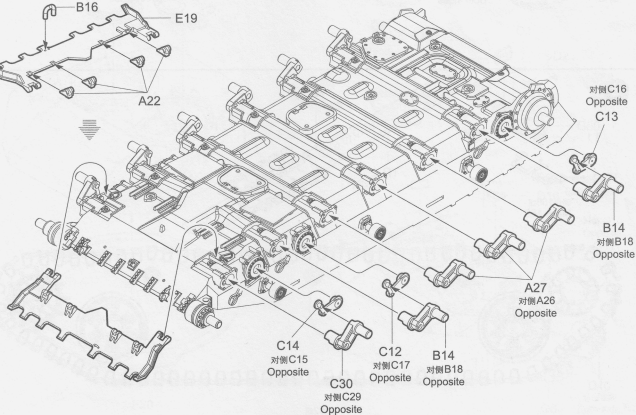
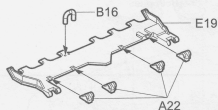
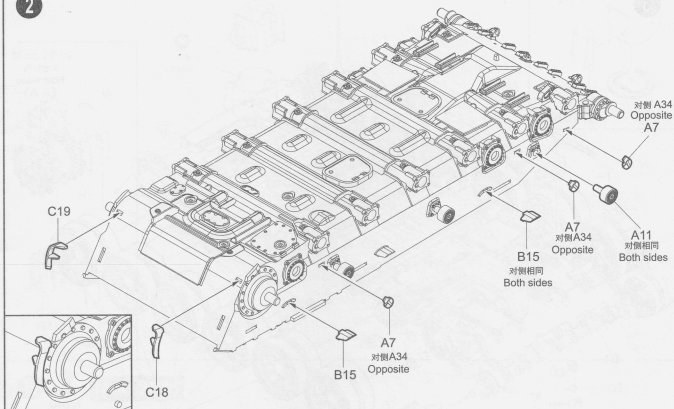

3

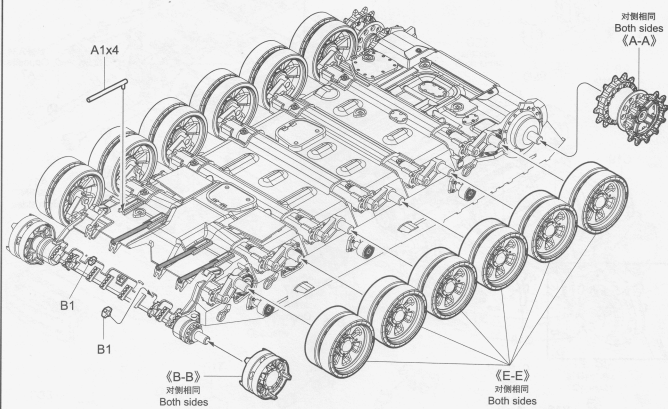

4

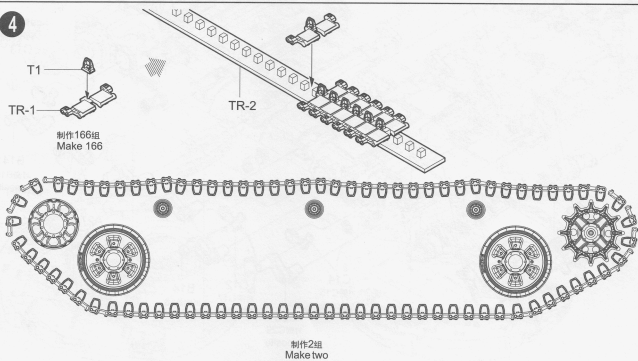

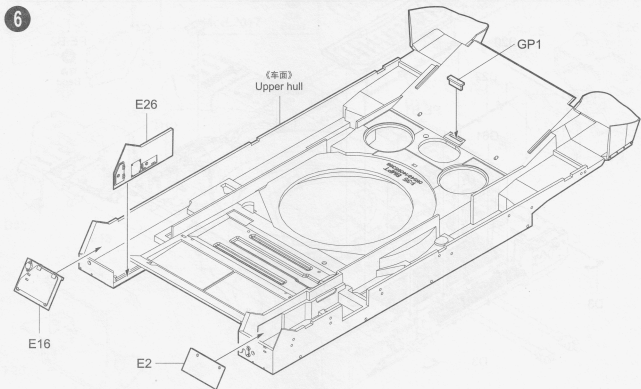
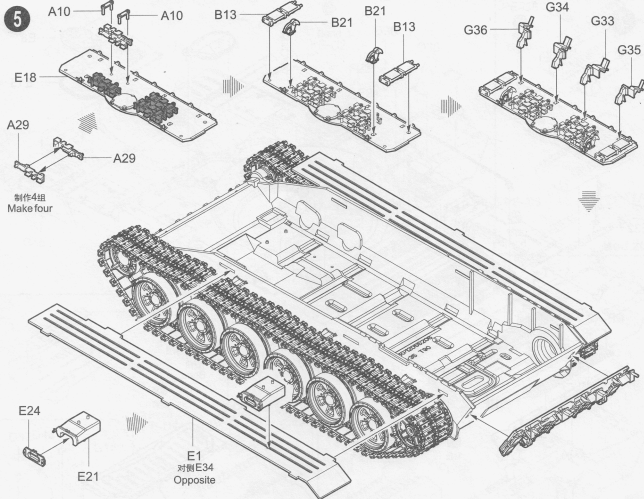

7

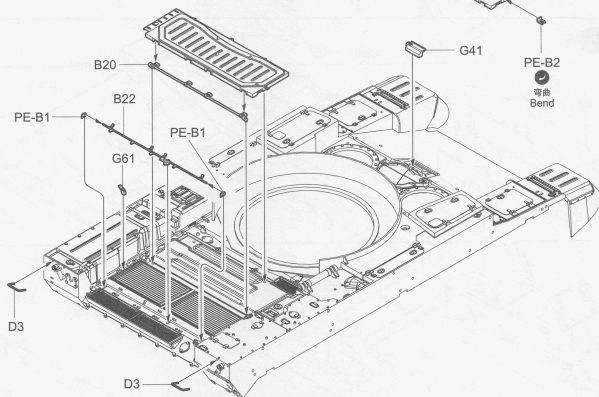
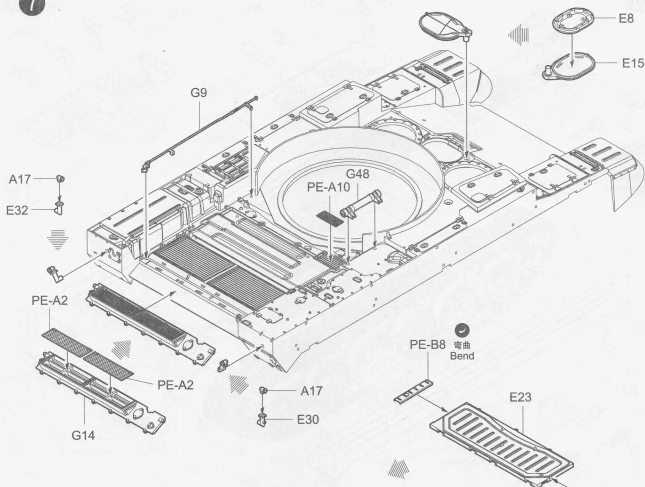



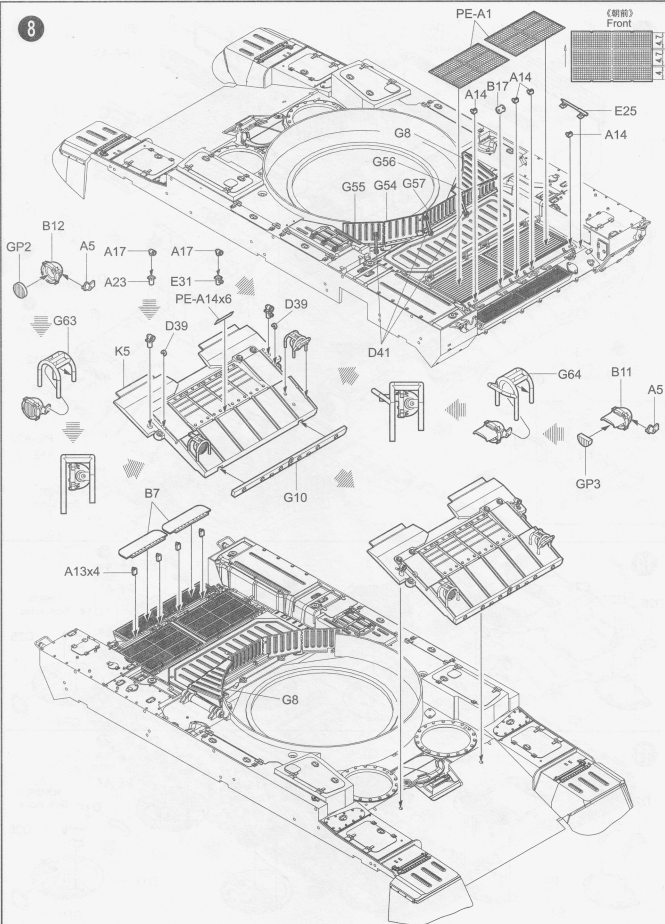

9

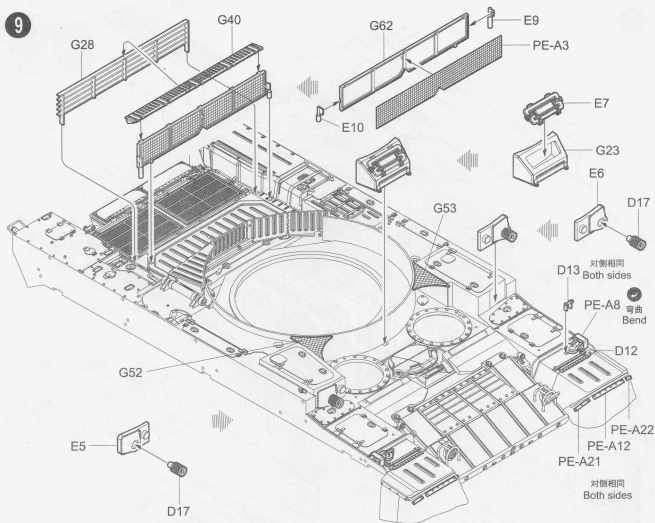

10

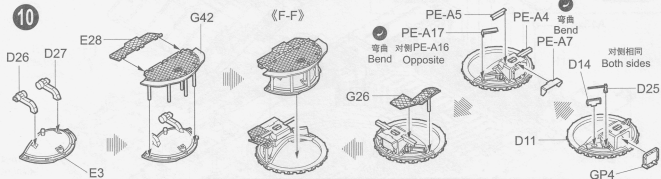

11

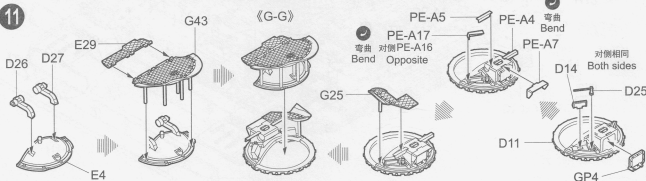

12

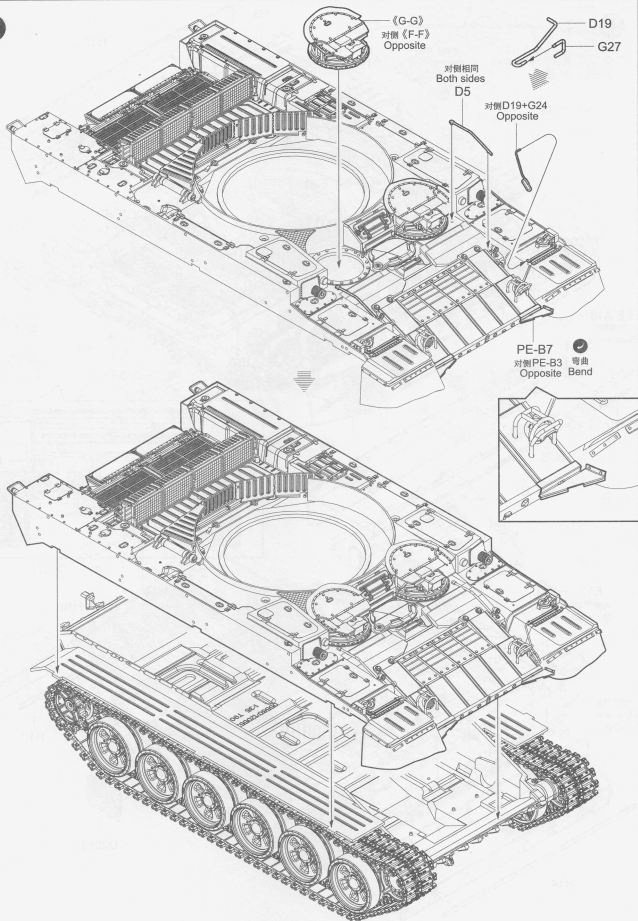

13

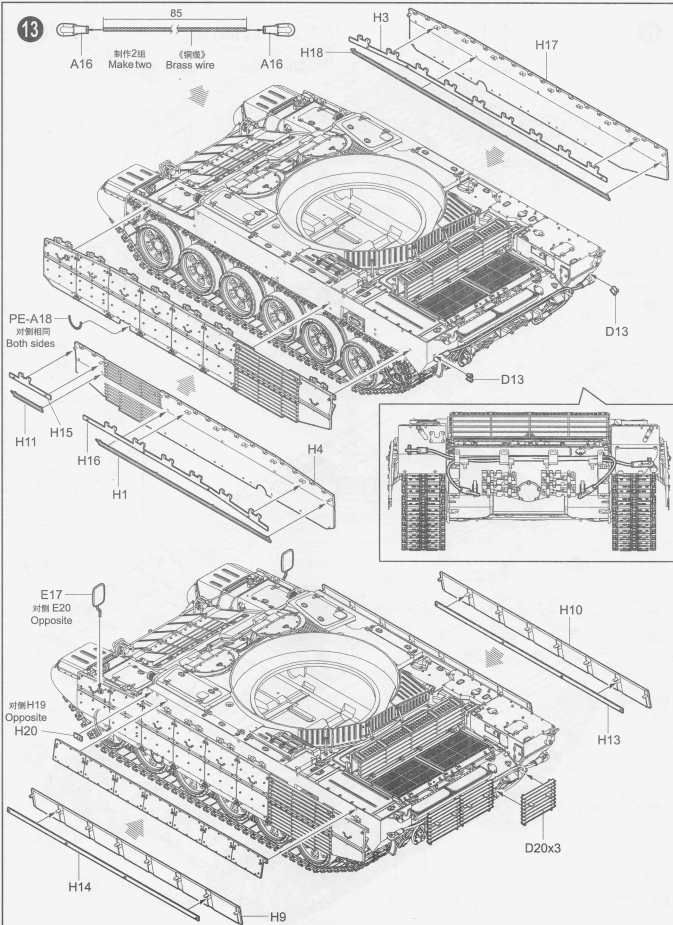

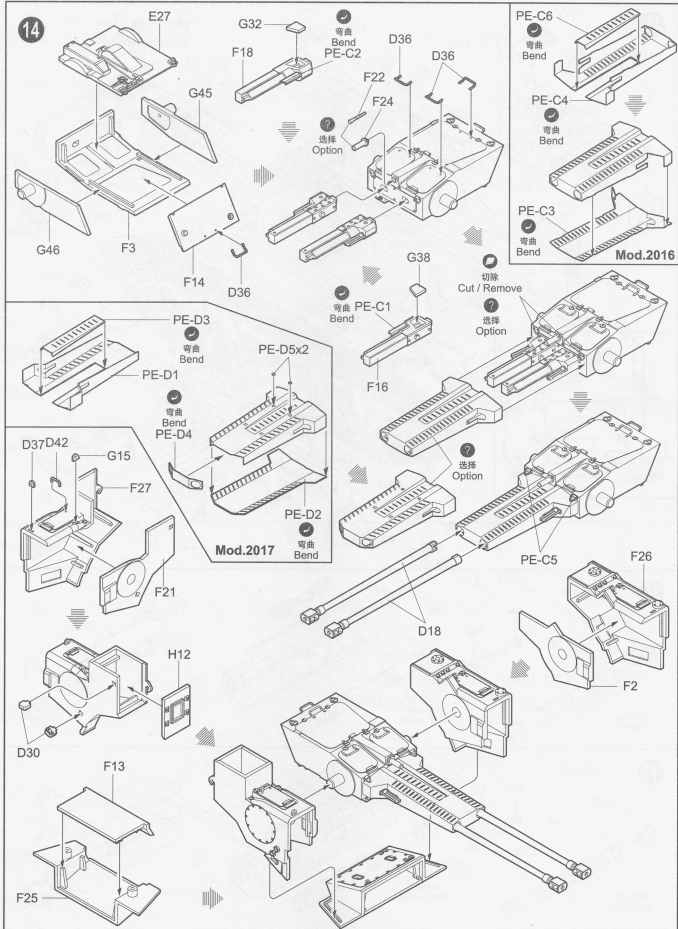

15

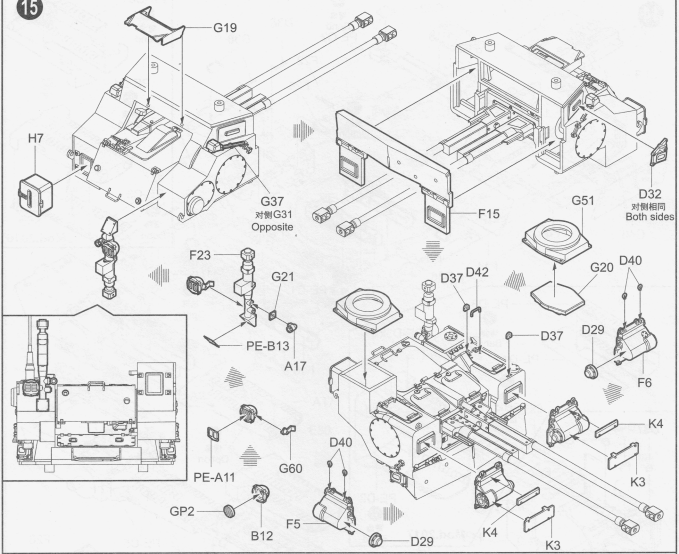

16

《H-H》

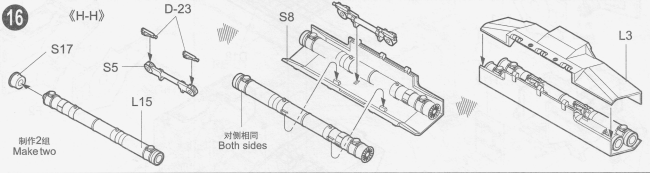

17

《J-J》

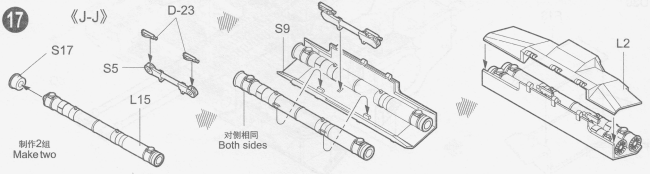

18

Mod.2016

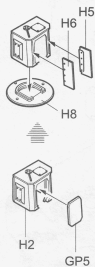

选择  
Option

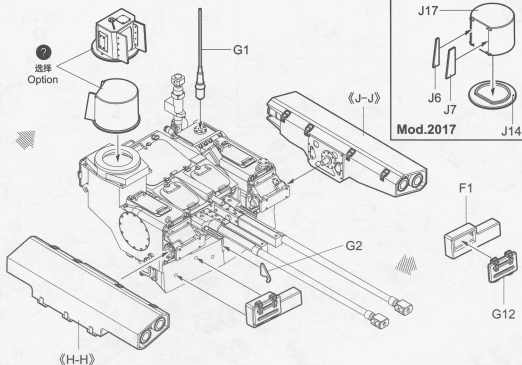

19

选择  
Option

Mod.2016

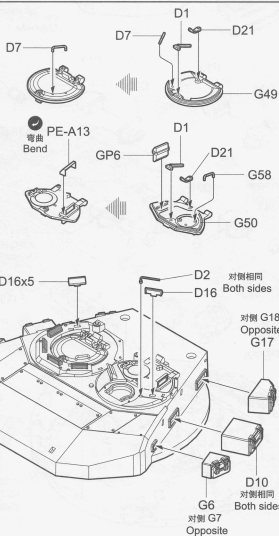
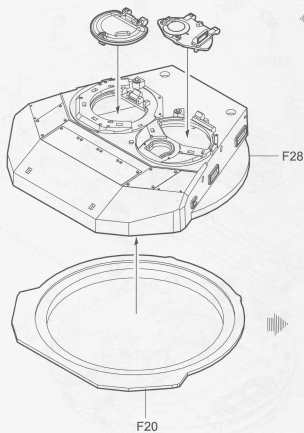

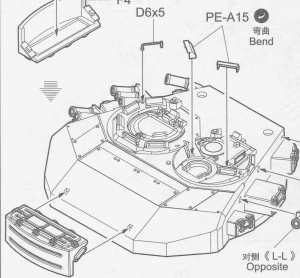
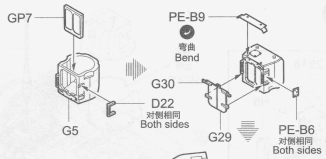
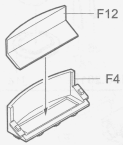
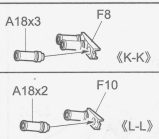

对侧 G3 Opposite G4

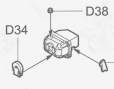
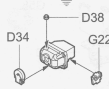
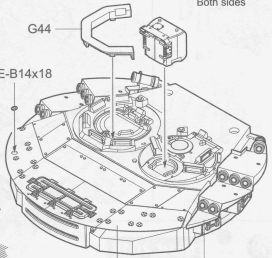

F11 对侧 G16 Opposite

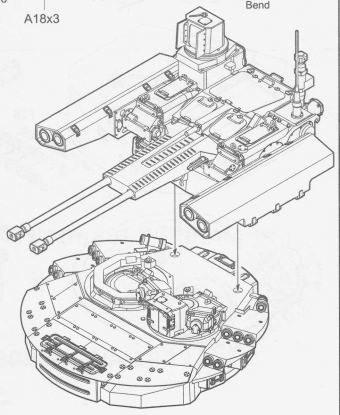
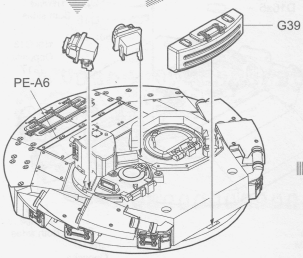



20

选择  
Option

Mod.2017

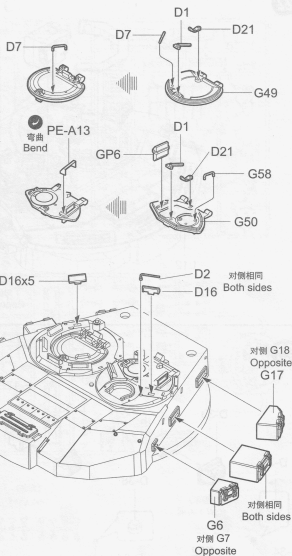
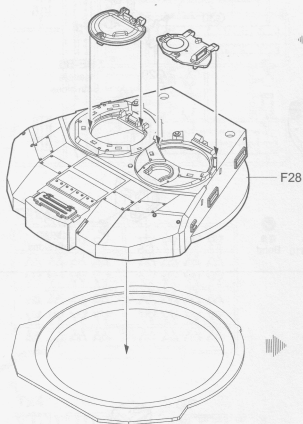

21

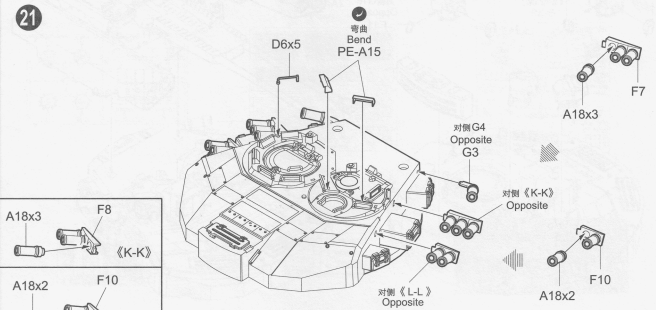

22

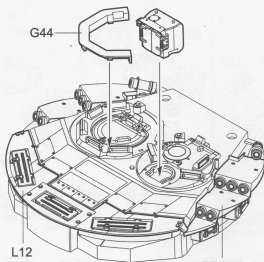

PE-B12  
 对侧 PE-B10  
 Opposite PE-B10



弯曲  
 Bend

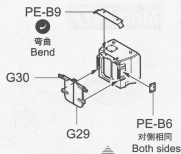

PE-B9  
 弯曲  
 Bend

PE-B6  
 对侧相同  
 Both sides



GP7

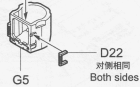

G5

D22  
 对侧相同  
 Both sides

23

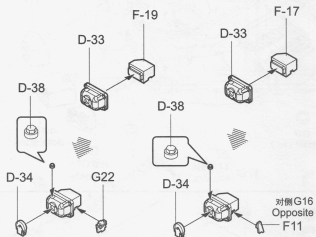

对侧 G16  
 Opposite  
 F11

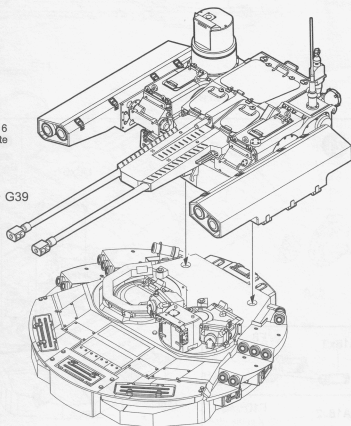

G39

