

1. MiG-29B "Puma" Squadron, before the last flight sometimes in the middle of 2009.  
"MH 59. Szentgyörgyi Dezső" Air Basis, Kecskemét.

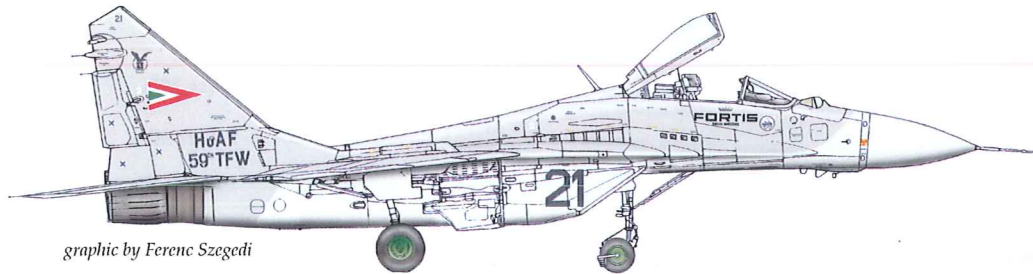

2. MiG-29B "Dongó" Squadron, before the last flight sometimes in the middle of 2009.  
"MH 59. Szentgyörgyi Dezső" Air Basis, Kecskemét.



3. MiG-29 UB "Dongó" Squadron, before the last flight sometimes in the middle of 2009.  
"MH 59. Szentgyörgyi Dezső" Air Basis, Kecskemét.

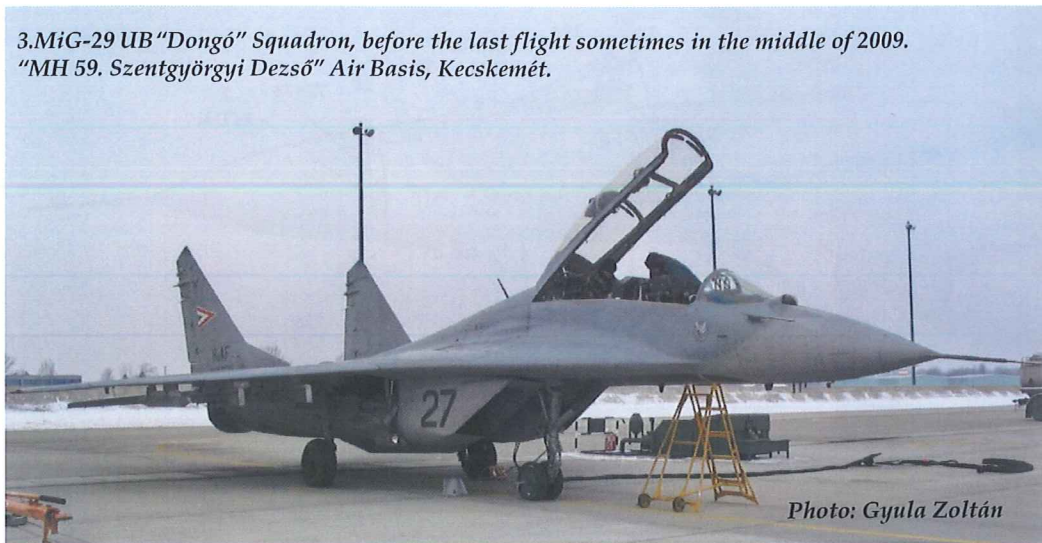

# MIG-29 B HUNGARIAN STENCILS AND DATAS IN NATO SERVICE

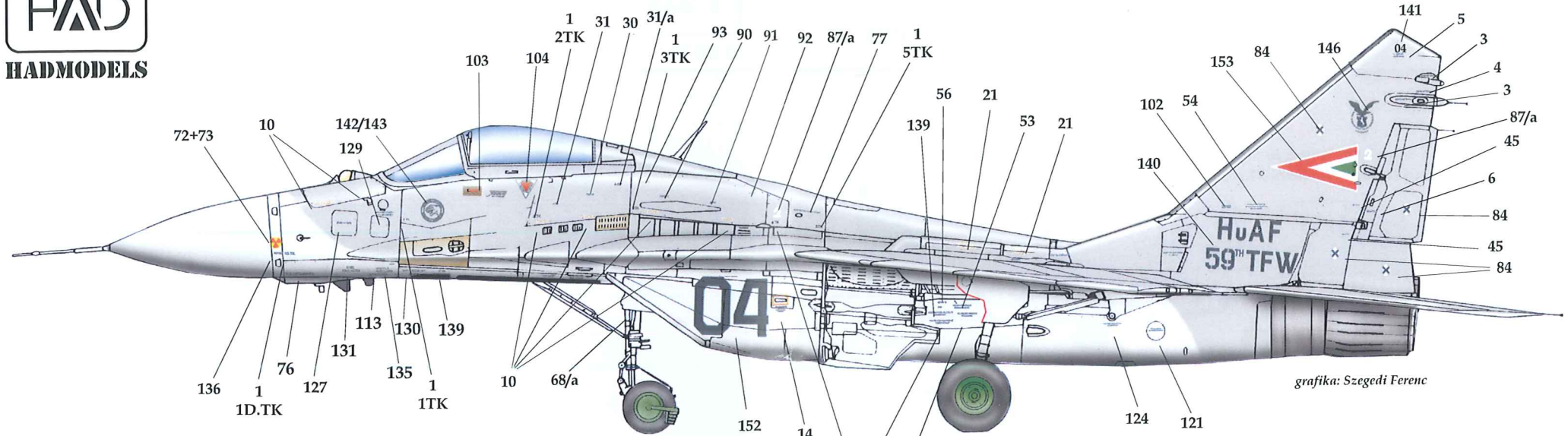

grafika: Szegedi Ferenc

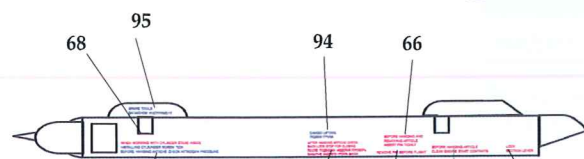

- Gunze H53 80 %+ White 20%
- Gunze H315 50 %+ White 50%

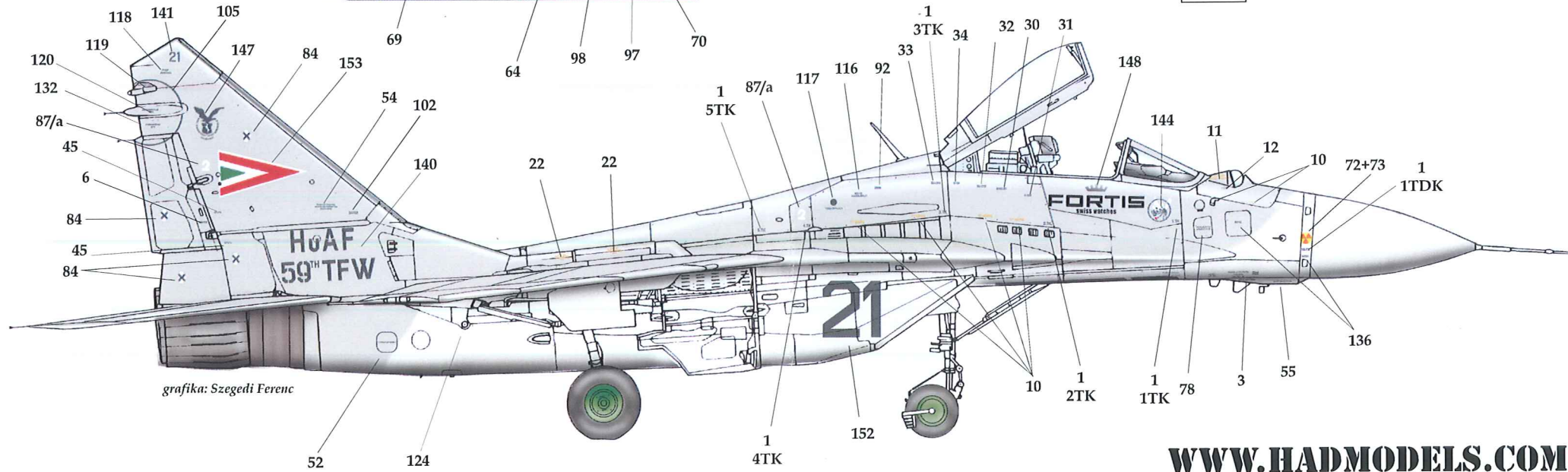

grafika: Szegedi Ferenc

# MIG-29 B HUNGARIAN STENCILS AND DATAS IN NATO SERVICE

Top View

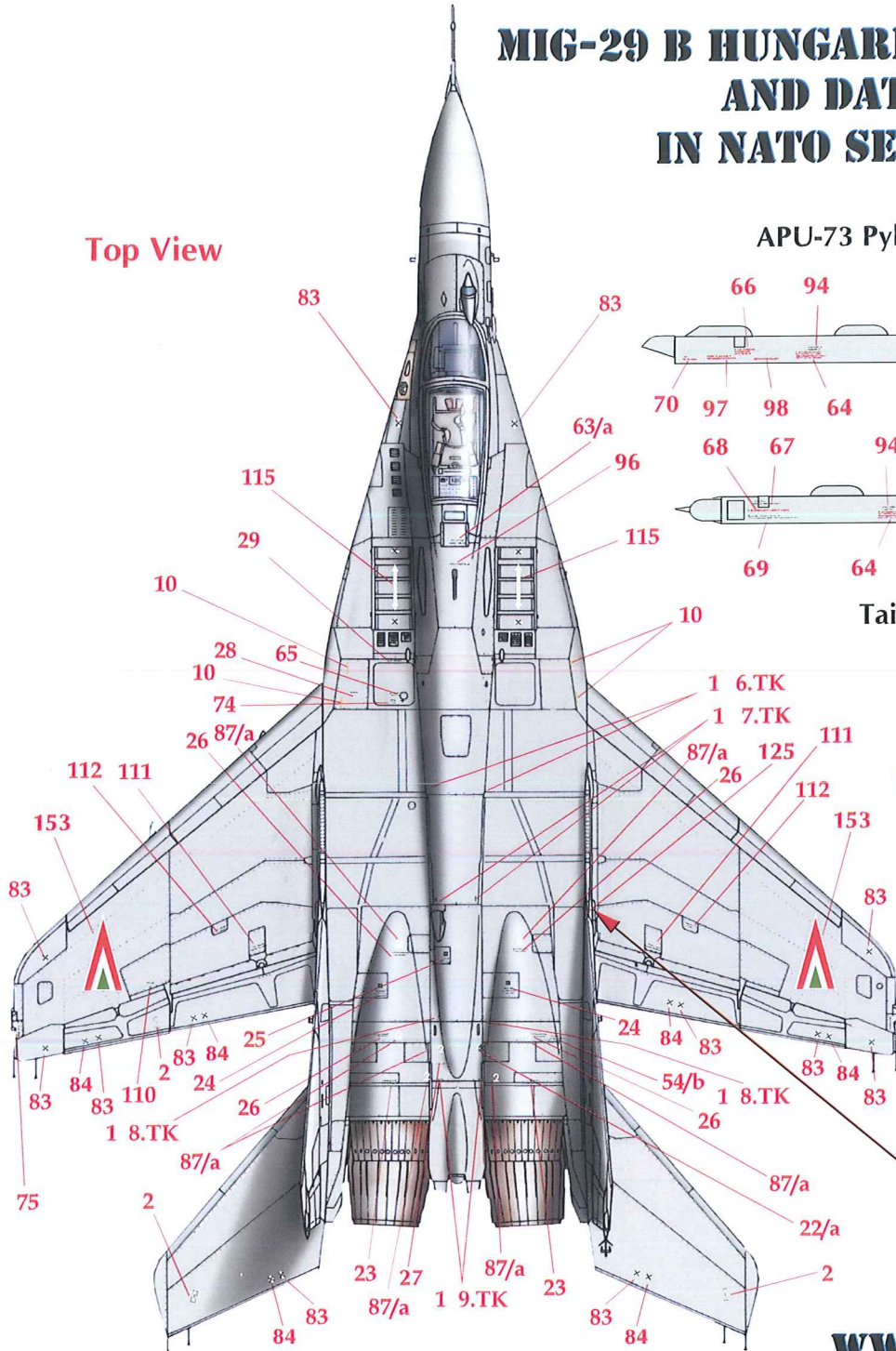

APU-73 Pylon

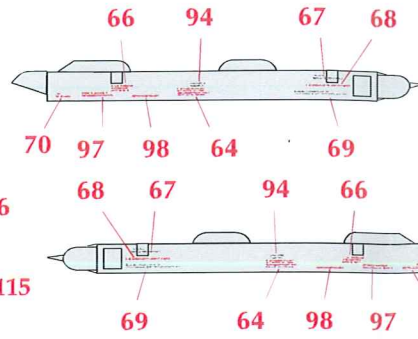

Tail inside view / left

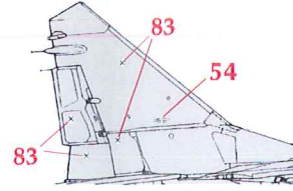

Tail inside view / right

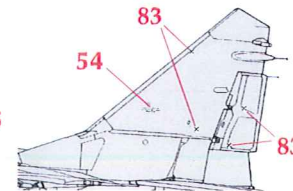

left side

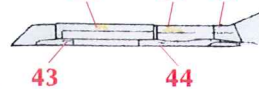

right side

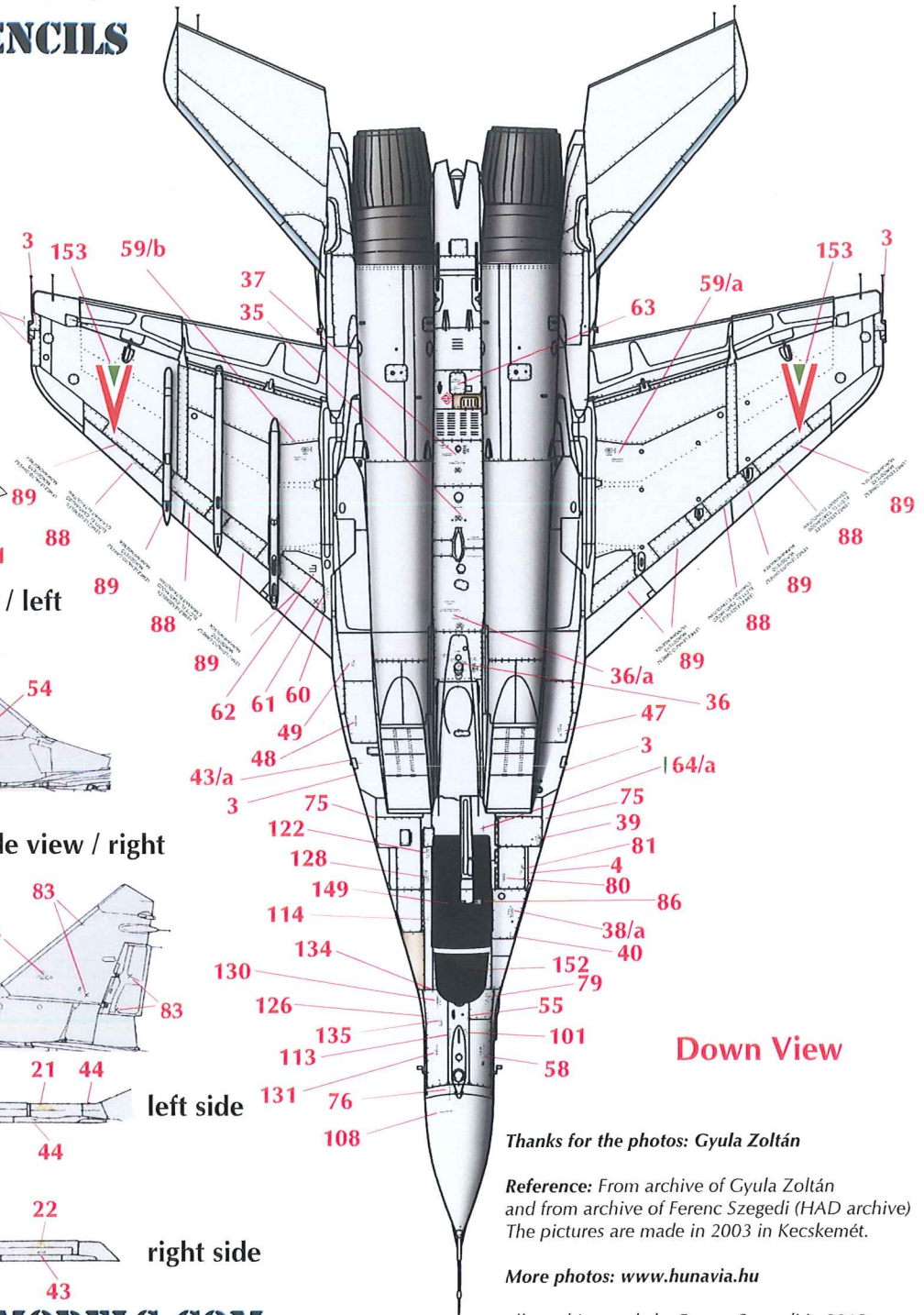
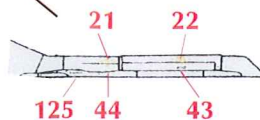

Down View

Thanks for the photos: Gyula Zoltán

Reference: From archive of Gyula Zoltán and from archive of Ferenc Szegedi (HAD archive) The pictures are made in 2003 in Kecskemét.

More photos: [www.hunavia.hu](http://www.hunavia.hu)

all graphics made by Ferenc Szegedi in 2012.