

## Avenger/Tarpon Mk I

**Grumman Avenger TBF-1 /TBM-1 /Tarpon**

Designed as a replacement for the Douglas TBD Devastator, the prototype XTBF-1 flew on 7 August 1941. Production started soon after and the aircraft redesignated TBF-1. General Motors built the TBM version although it was the same aircraft, as was the Tarpon GR1, the British version. It had subtle changes such as some bulged canopy glazing and other British made equipment, and later renamed Avenger TDF-1. The Avenger was the heaviest single engined aircraft of WWII. It used the Grumman 'Sto-wing' wing-fold system to maximize storage space on carriers. The TBF was powered by a Wright R-2600-20 Twin-Cyclone 14 cylinder engine producing 1900hp (1420kw) and had a 3 man crew: pilot, radioman/bombardier/ventral gunner, and turret gunner. Initially the TBF had a nose mounted 0.30 (7.62mm) MG, a single 0.50 (12.7mm) MG in the electrically driven rear turret, and a ventrally mounted 0.30 (7.62mm) MG operated by the radioman/bombardier. The nose mounted gun was replaced by a single 0.50 (12.7mm)MG in each wing (TBF-1c) The large bomb-bay could hold a Bliss-Leavitt Mk 13 torpedo, a single 2000lb (907kg) bomb, or up to 4 x 500lb (227kg) bombs. Some aircraft carried depth-charges, and could also drop mines.

The Royal Navy Fleet Air Arm along with the U.S. Navy used the Tarpon/Avenger for Atlantic convoy protection, warding-off German or sinking U-boats. About 30 submarine 'kills' were recorded for the North Atlantic. These aircraft operated off escort carriers. Land based aircraft were also used to drop mines. One Avenger destroyed a V-1 flying-bomb. As the V-1 approached the Avenger from the rear, the 'telegraphist' ventral gunner shot down the V-1 from about 700 yards (640m).

Royal Navy Fleet Air Arm Avengers were used in June 1945 raids on Soengei Gerong oil refinery at Palembang, South Sumatra, Indonesia during operation Meridian. A Nakajima Ki-44 'Tojo' was also shot down in low level combat.

SWORDMODELS s.r.o. Těšínská 288  
739 34 Šenov  
CZECH REPUBLIC

[www.swordmodels.cz](http://www.swordmodels.cz)  
e-mail: [swordmodels@gmail.com](mailto:swordmodels@gmail.com)

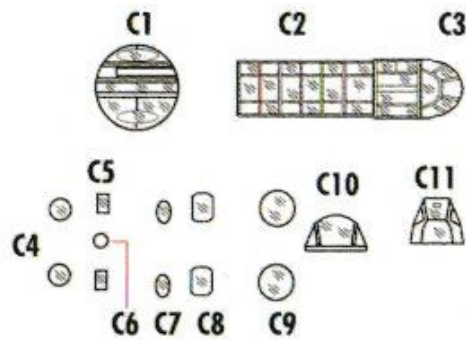
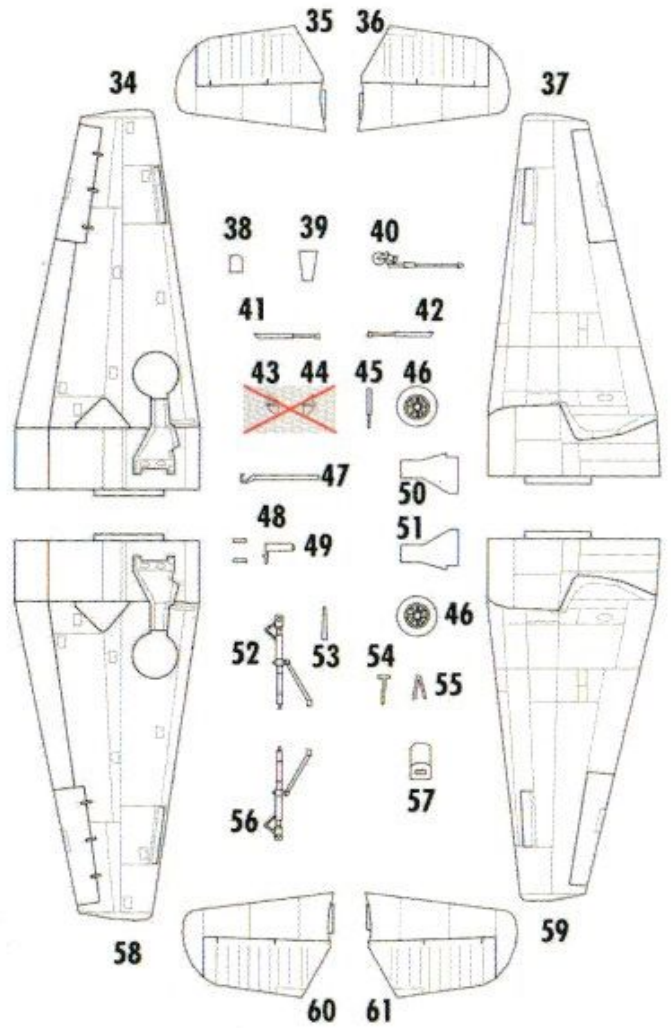
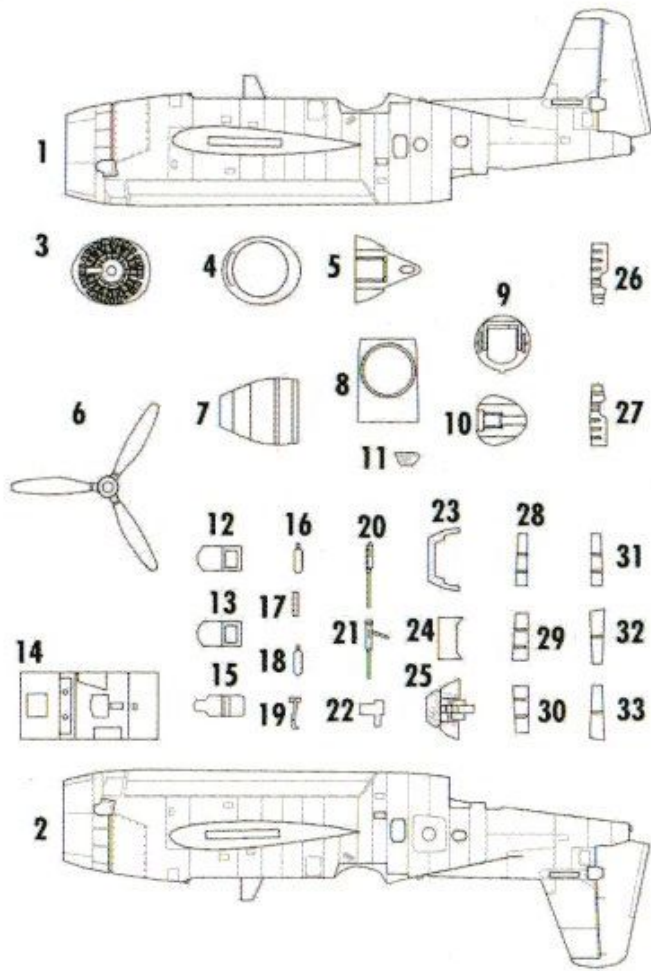

REMOVE



BEND



OPEN HOLE



SCRATCH BUILD



COLOR



SYMETRICAL ASSEMBLY



OPTION



SECOND GLUE



White



Light Grey



Exhaust



Tyres Black



Black



Bronze Green



Silver



Yellow



Chrome



Interior Green



Leather



Engine Grey

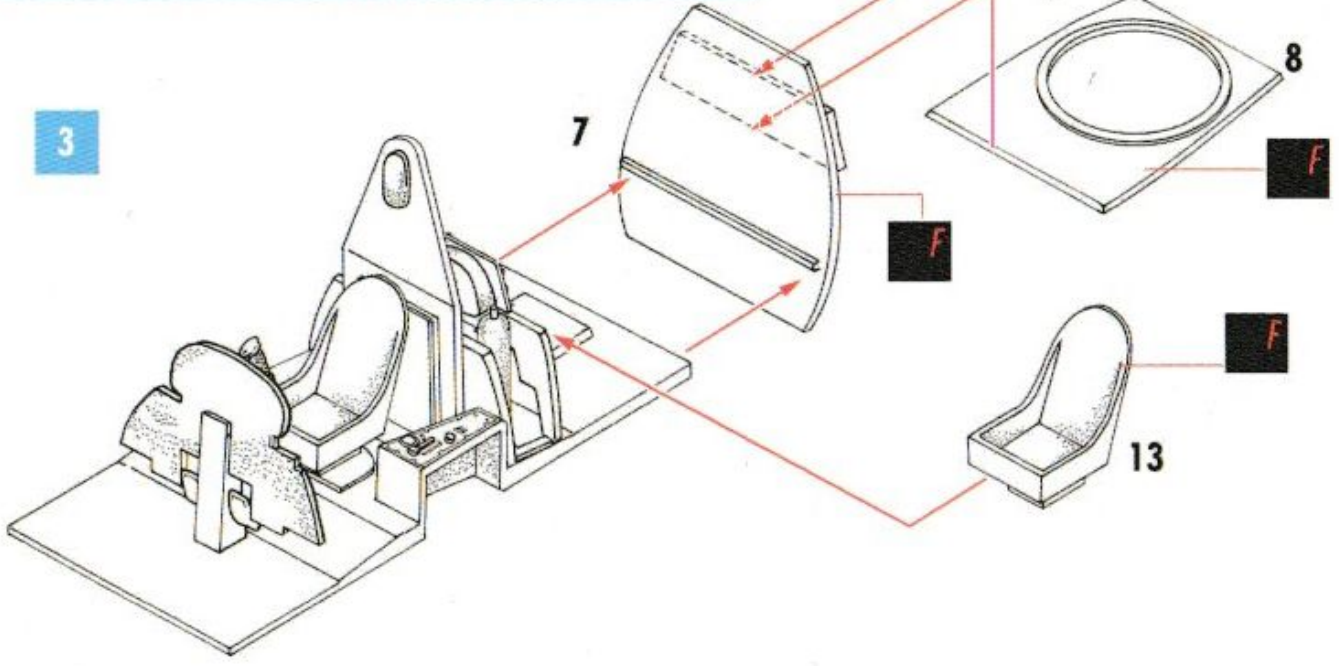
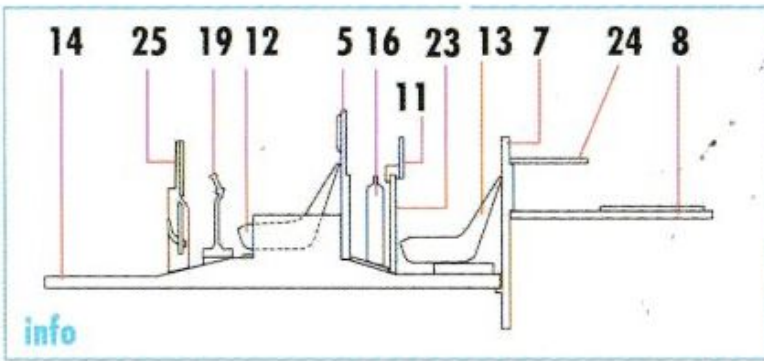
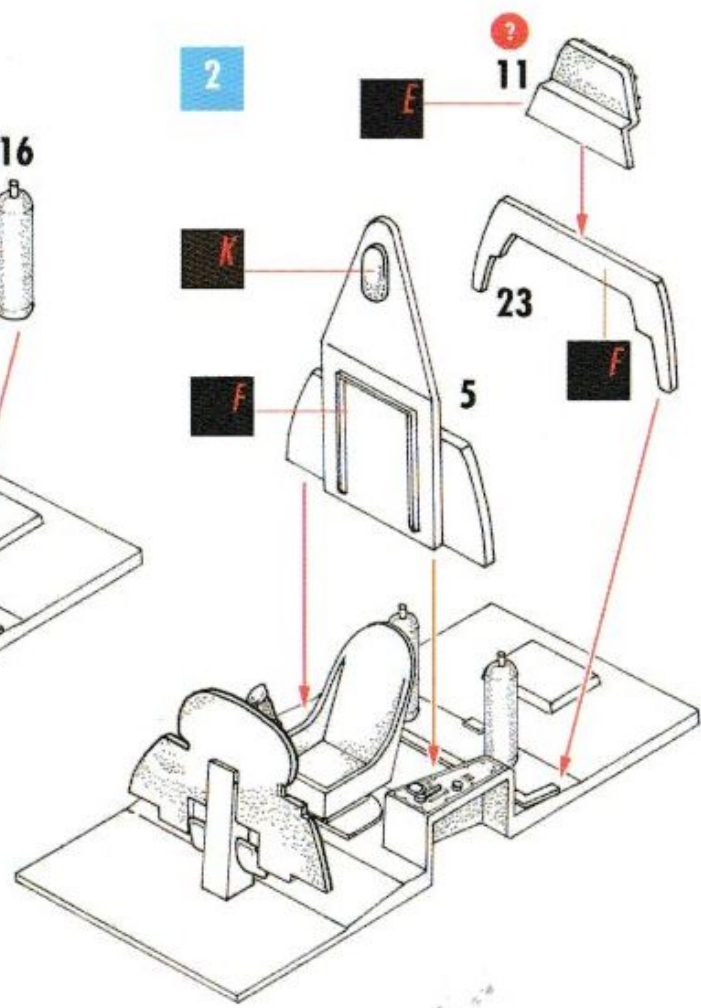
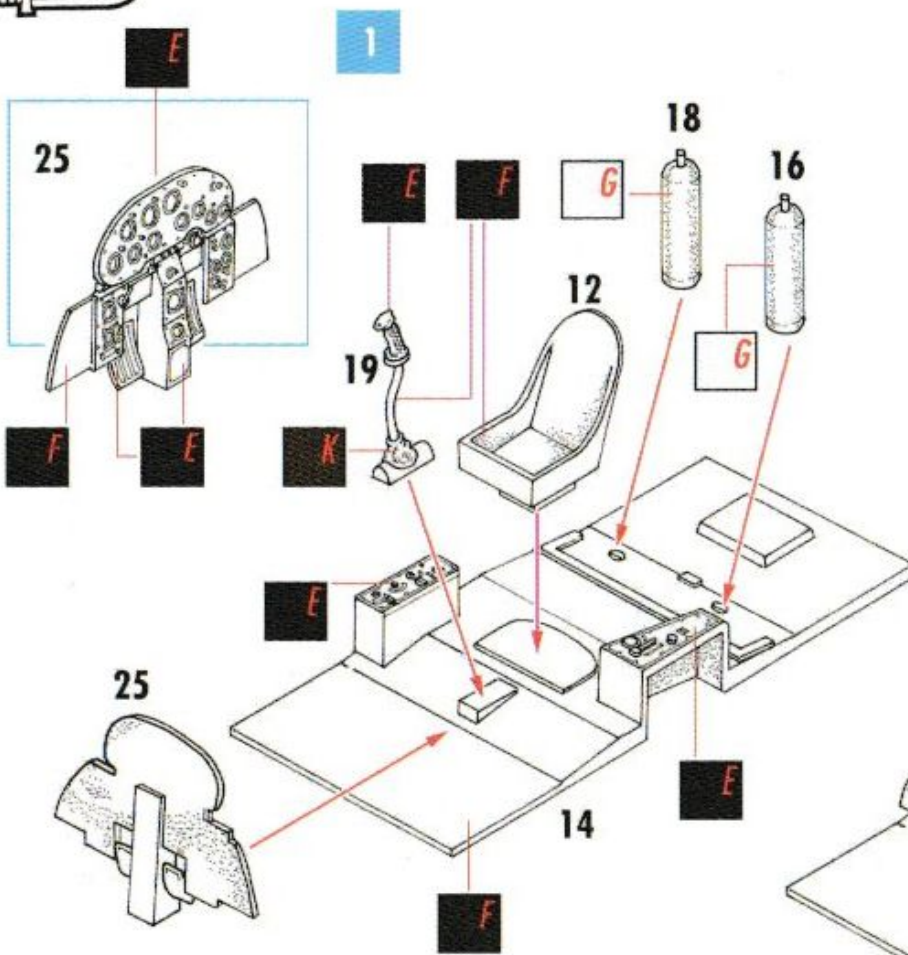

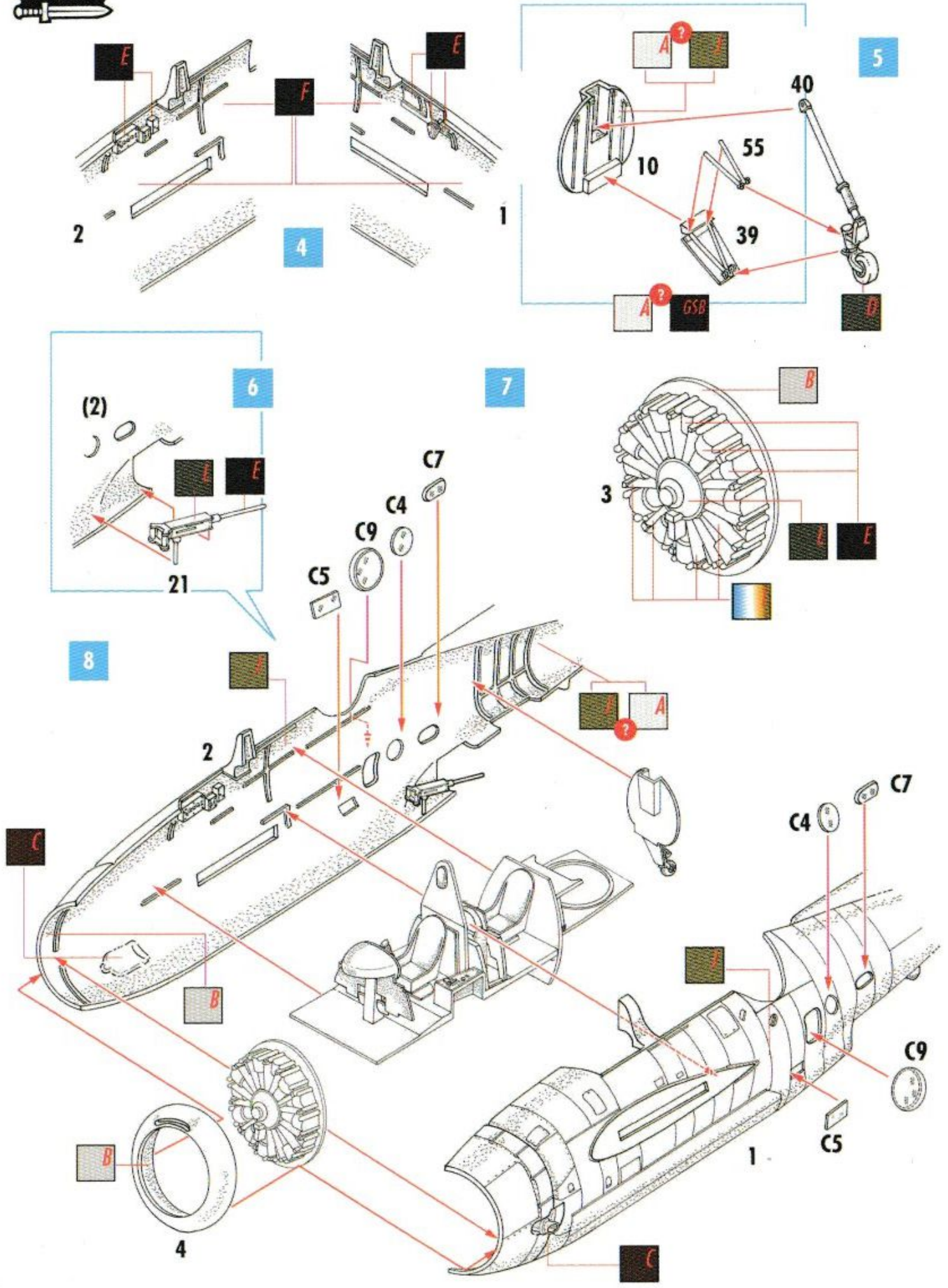

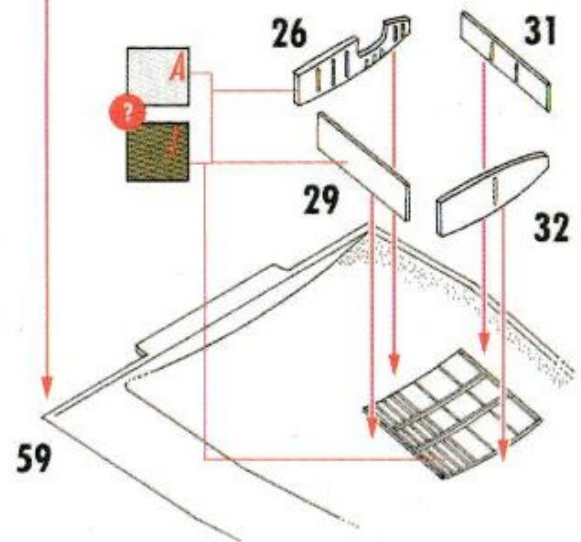
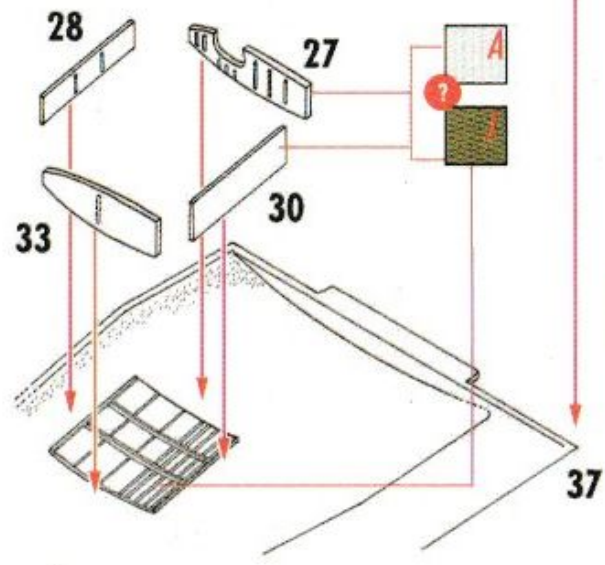
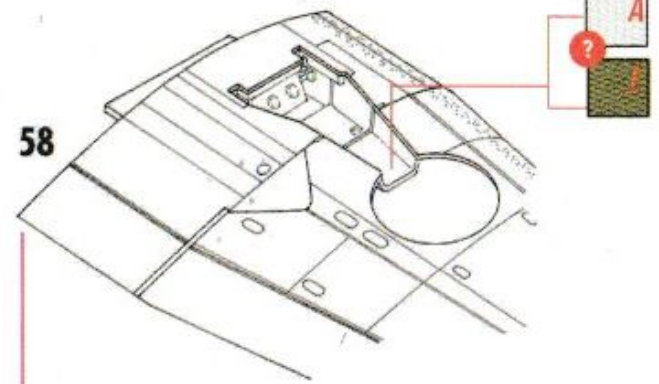
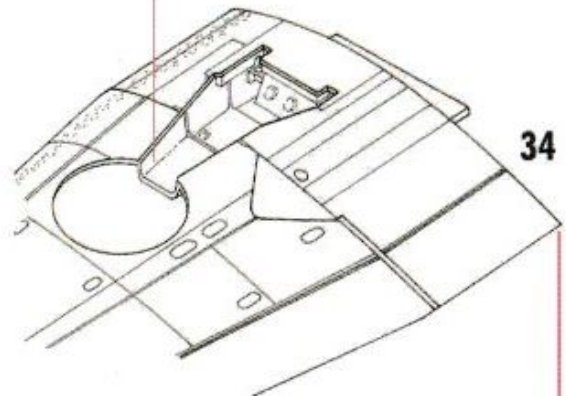
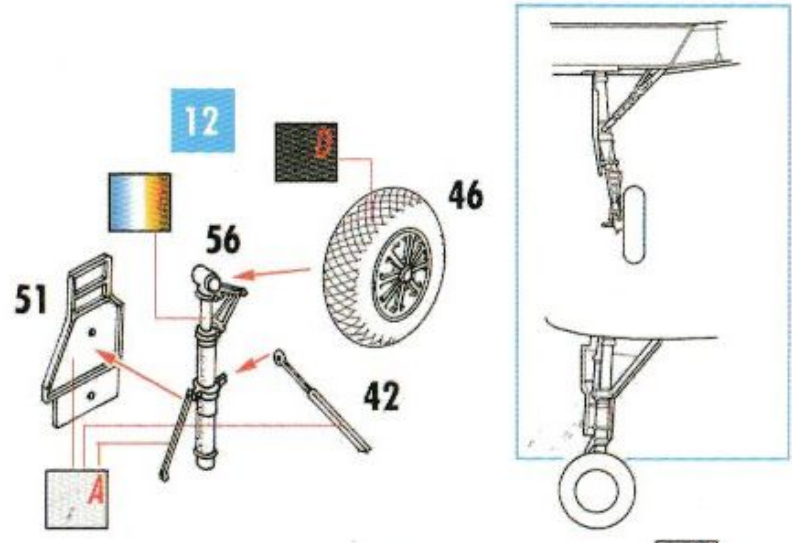
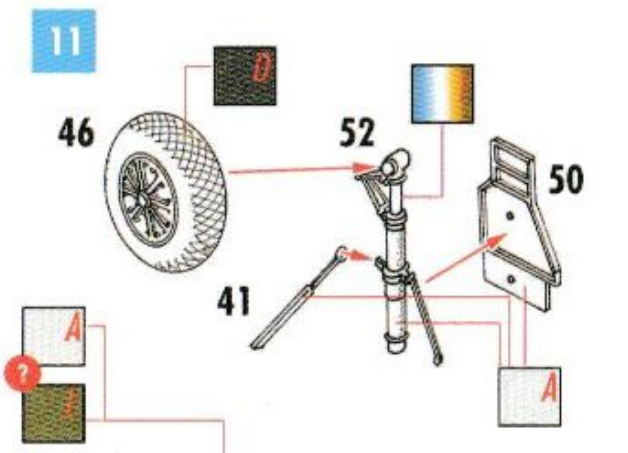
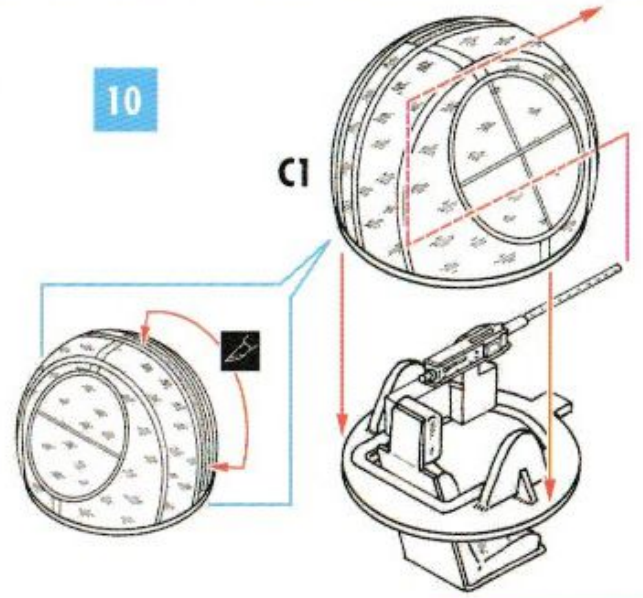
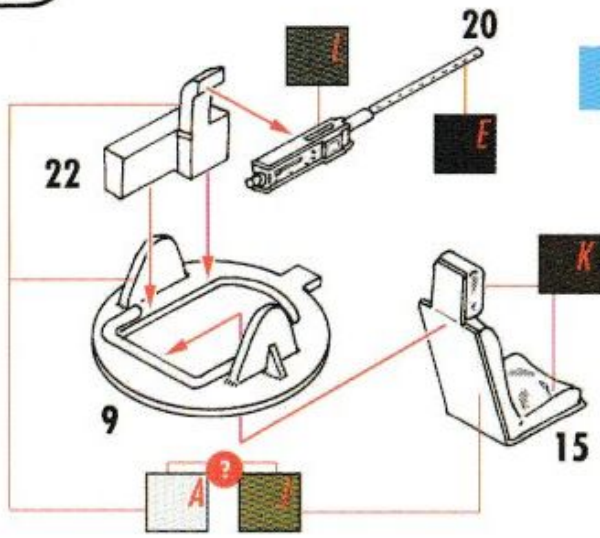

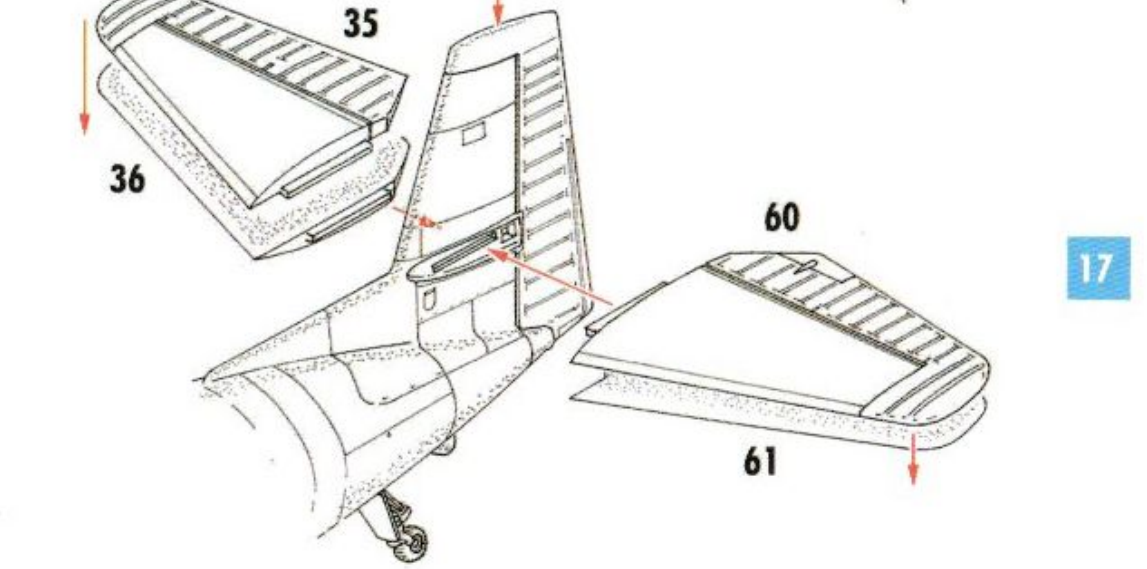
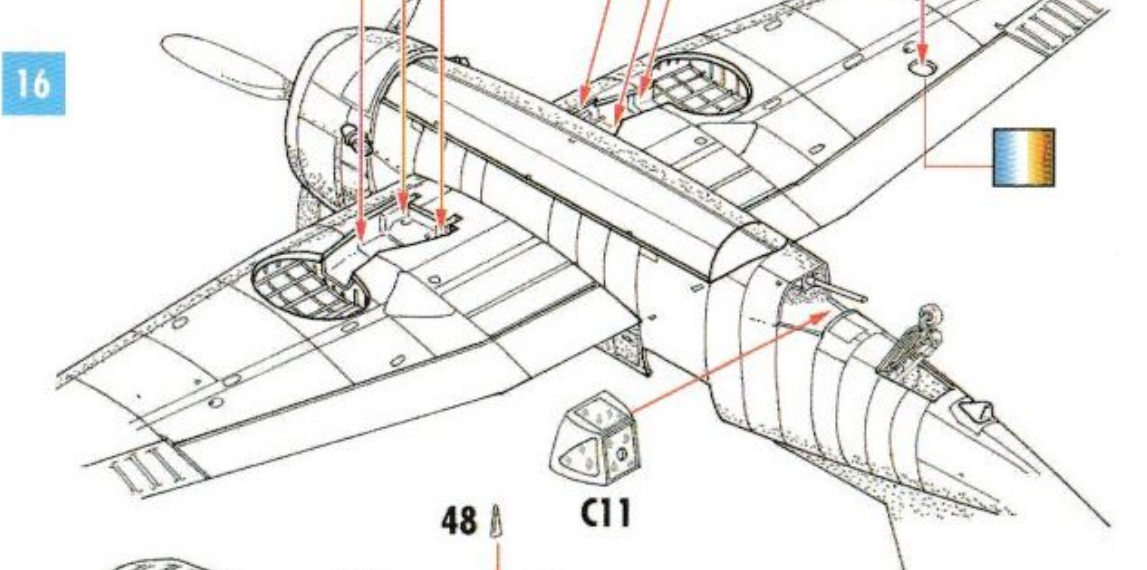
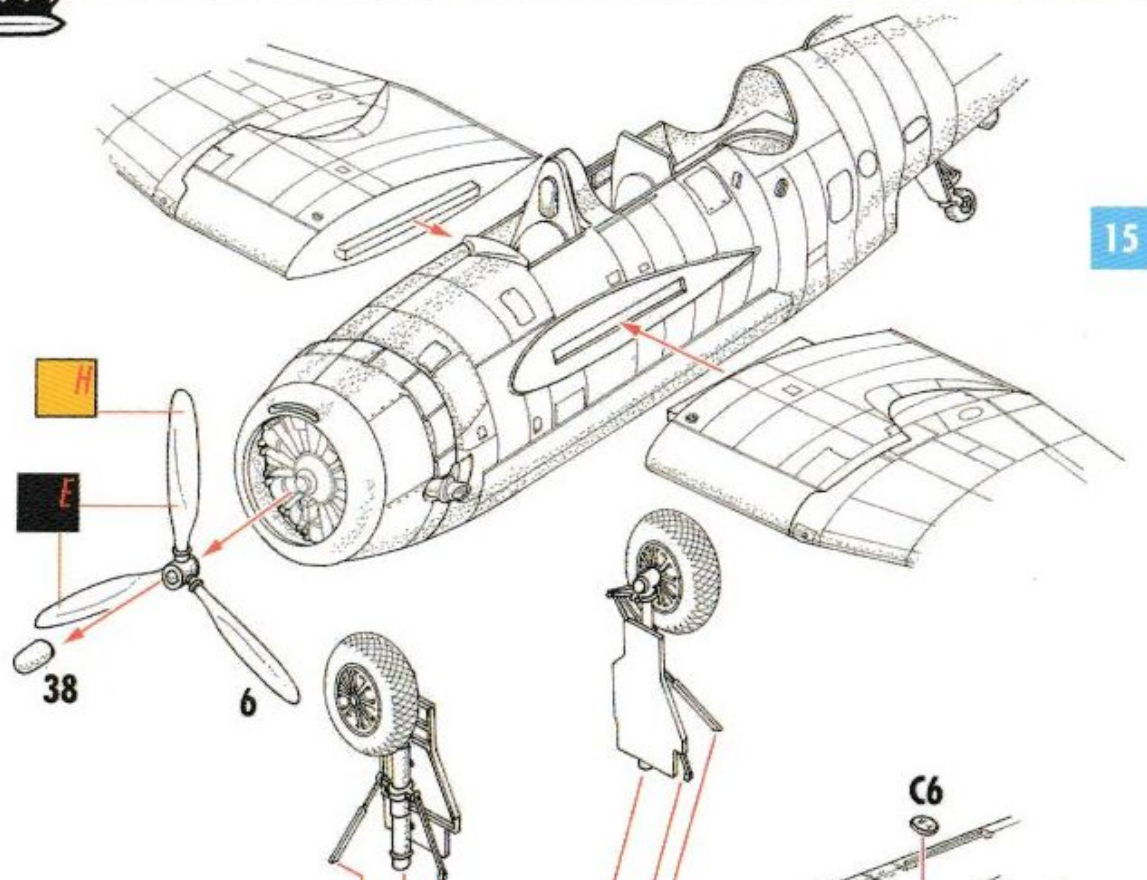

18

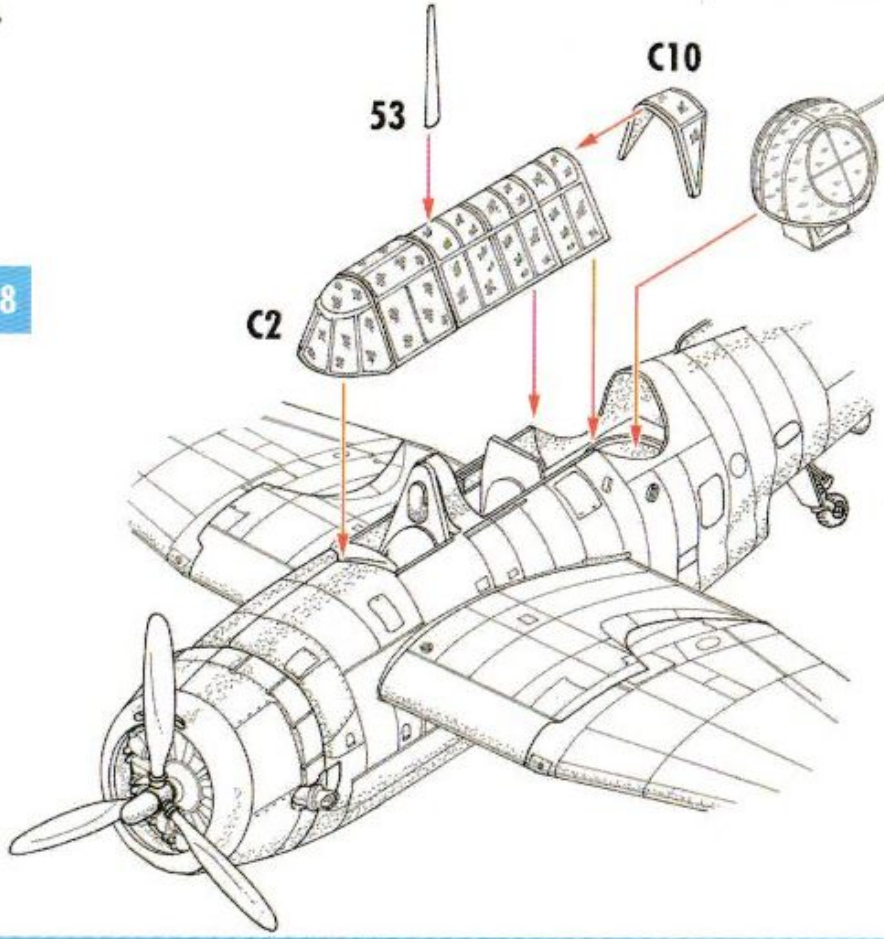

Stencil data

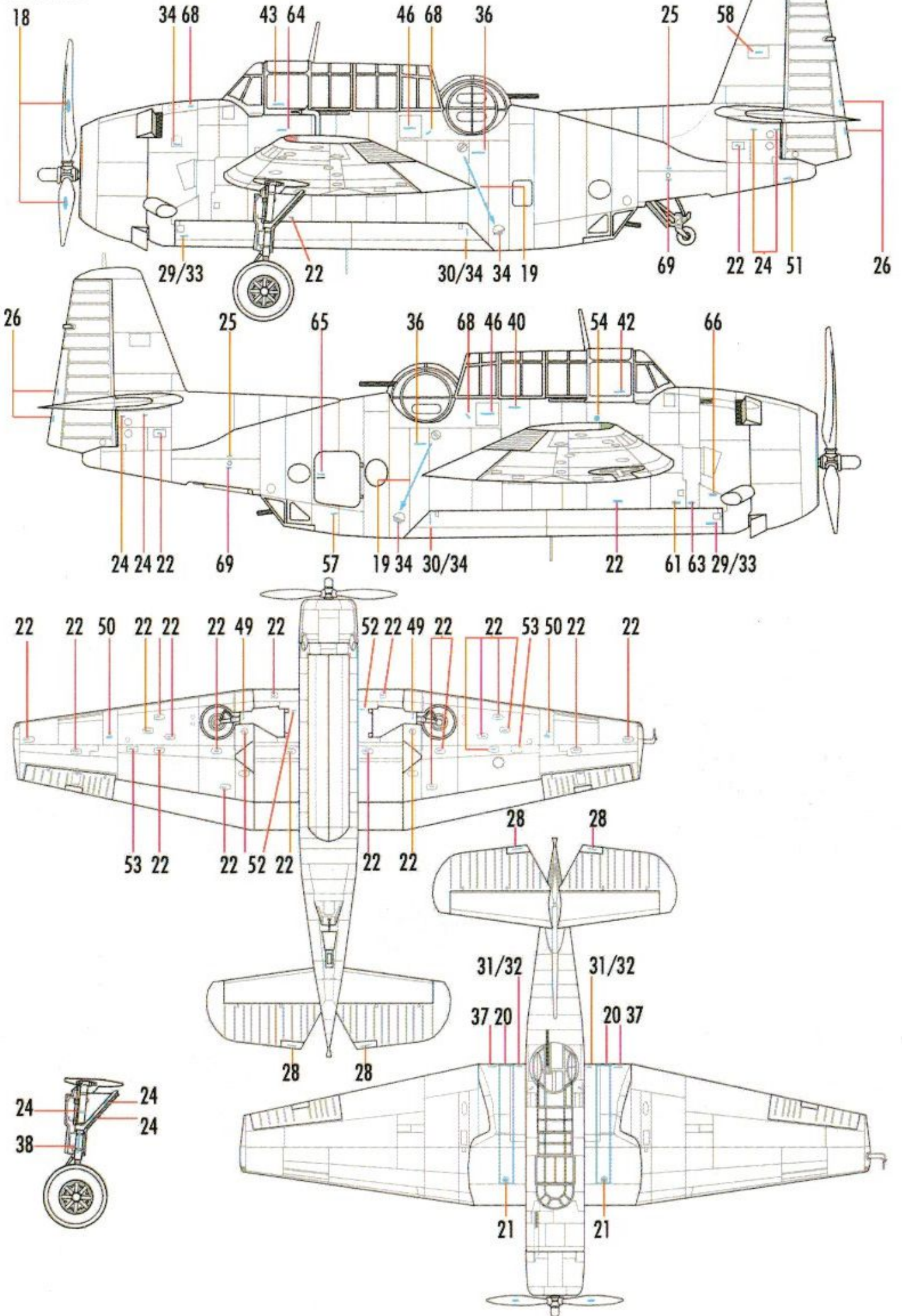



*Avenger/Tarpon I of no. 846 Sqn FAA during press day at RNAS Machrihanish in Scotland, December 1943.*

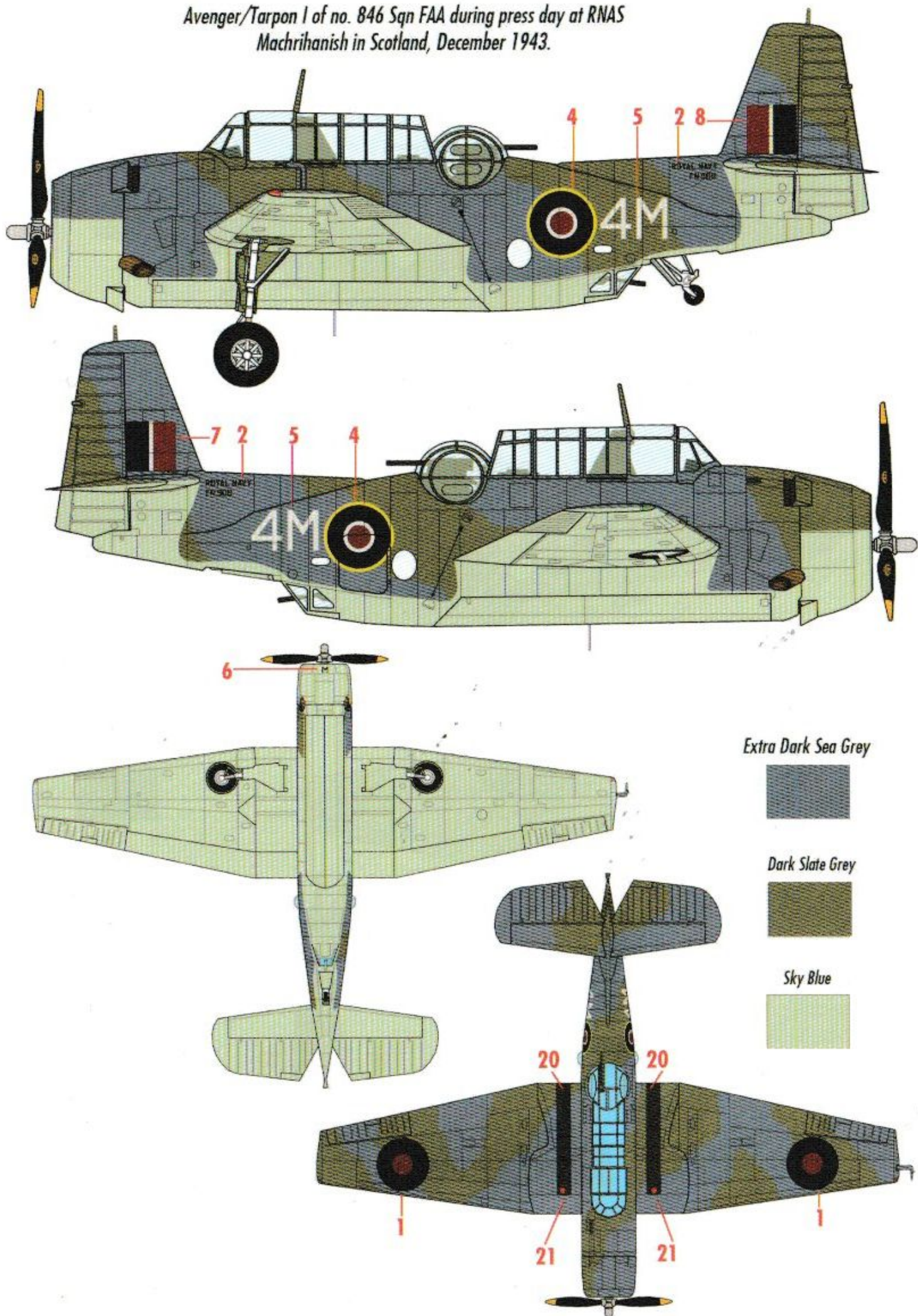

Avenger/Tarpon Mk.I, FN 817,Q4U of No 854Sqn.,HMS Illustrious, 1944

