

Diamond T 972 Dump Assembly Guide

Diamond T 972 was a dump truck based on a 4 ton 6x6 chassis, powered with a Hercules RXC six-cylinder gasoline engine and equipped with a five-speed overdrive transmission and a direct and under drive transfer, manufactured from roughly 1940 until 1945 by the Diamond T Motor Car Company in Chicago.

Design and development of the model 968 began in 1939, it was adapted for production in 1940, and produced from 1941 to 1945. From 1943 most trucks were fitted with open cab.

These vehicles were also supplied to the Allied countries through the Lend-Lease Act, and after the WWII numbers of them were still in use in various countries for many years

Parts:

Sprue A - single chassis parts, 2x sprue B - chassis parts and wheels, sprue C - engine, sprue D - bonnet and front cab parts, sprue S - cab parts, sprue X - cargo body parts, sprue U - clear parts, chain, decals, PE sheet

Go through assembly guide before you start your work. Some gates on this kit sprues are larger, because we don't want any ejector marks on parts, and also very thin true-to scale parts require larger gates to avoid filling issues, you need to use a little razor blade or sharp scalpel to remove these parts carefully.

Working with PE parts:

Heat up PE parts with lighter before use, brass will soften and become easy to bend and work with

Tamiya Super Thin Glue Gunze Mr. Cement or other ABS plastic glues are recommended for plastic parts, let the glue work for a few seconds, then push parts together, melted plastic will fill the gaps between parts. You can also melt sprue frame and use it as an amazing filler for small works, or use this glue to wash out tiny seam lines on little parts or make texture on some parts etc. Fair amount of glue is necessary to melt ABS that is harder than usual styrene, but most of sprues in this kit are produced in usual polystyrene.

front wheel- make two

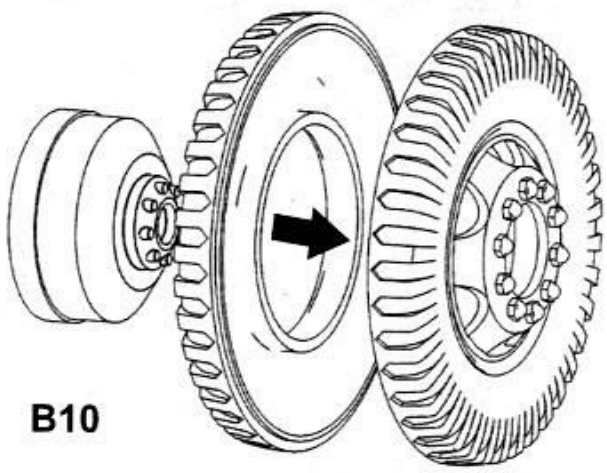

B10

B23

B21

wheels

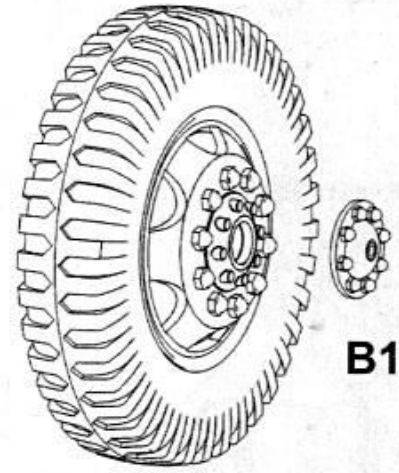

B11

spare wheel
drill holes marked at
the back - make two

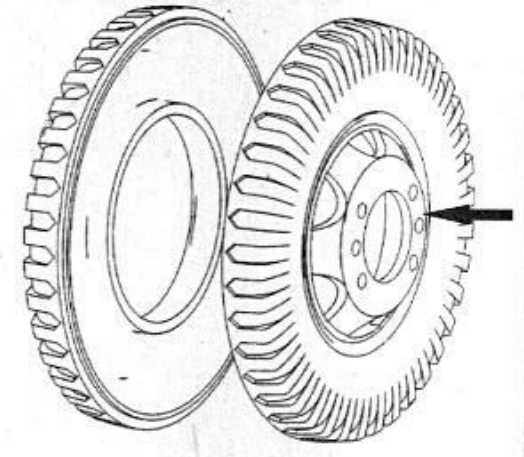

B23

B20

rear wheels - make four sets

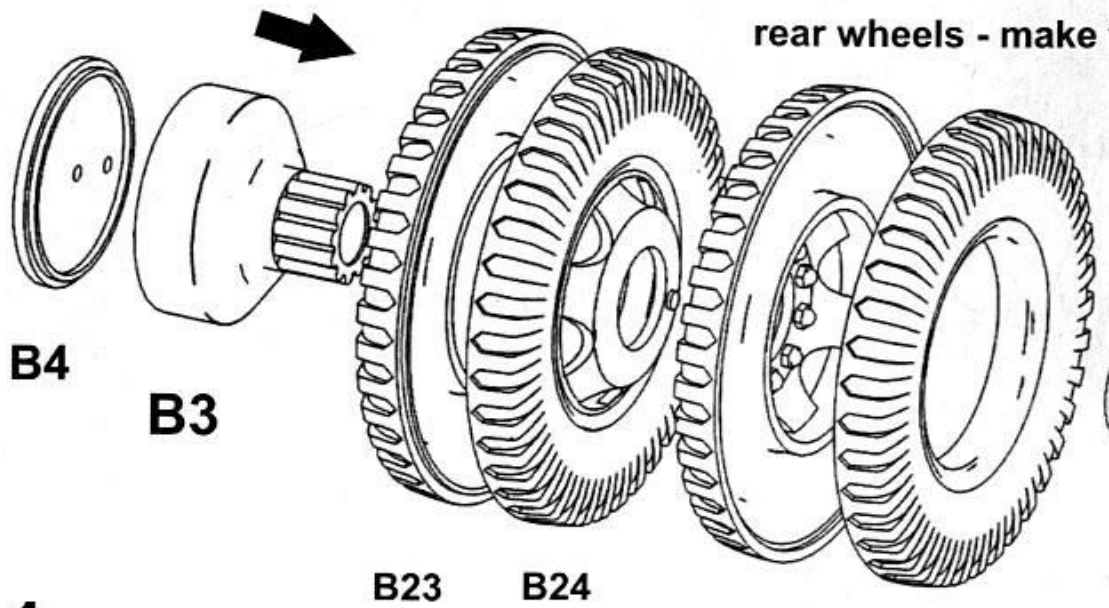

B4

B3

B23

B24

B22

B23



B1

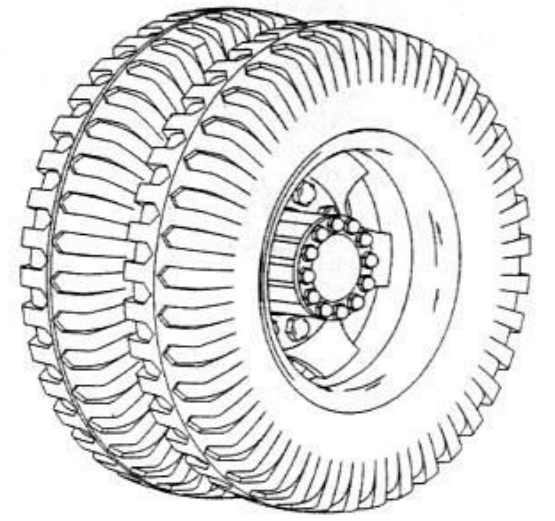

1

Engine

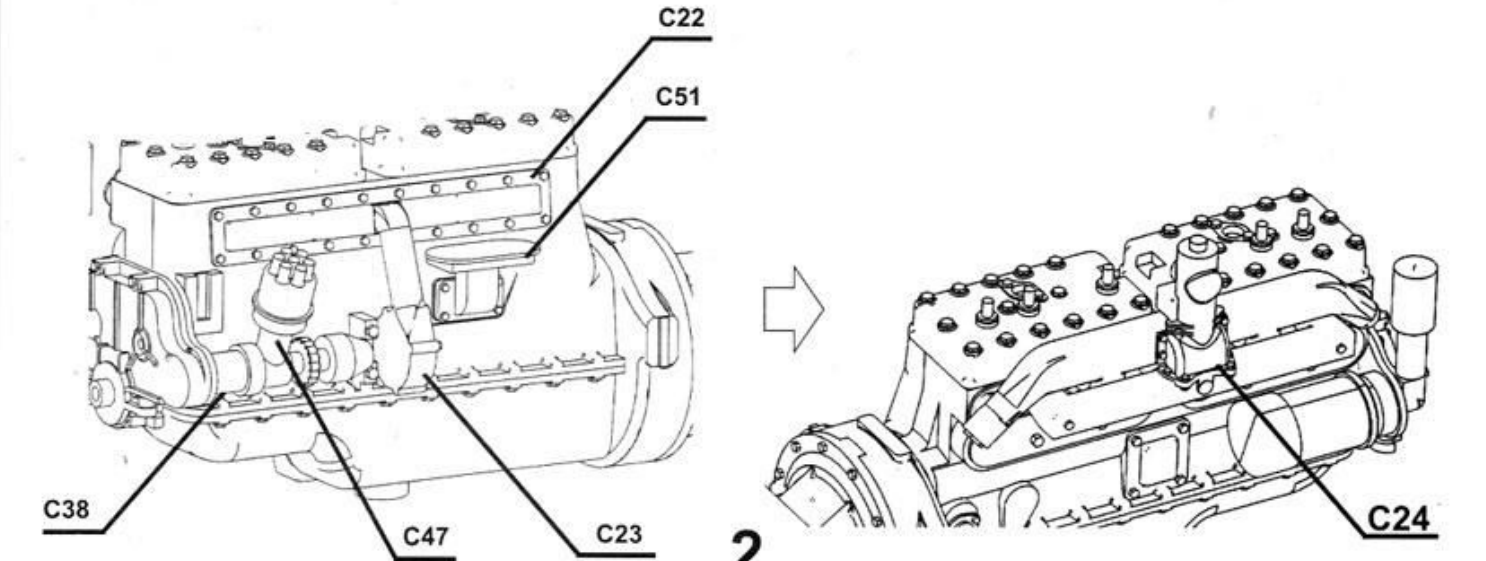
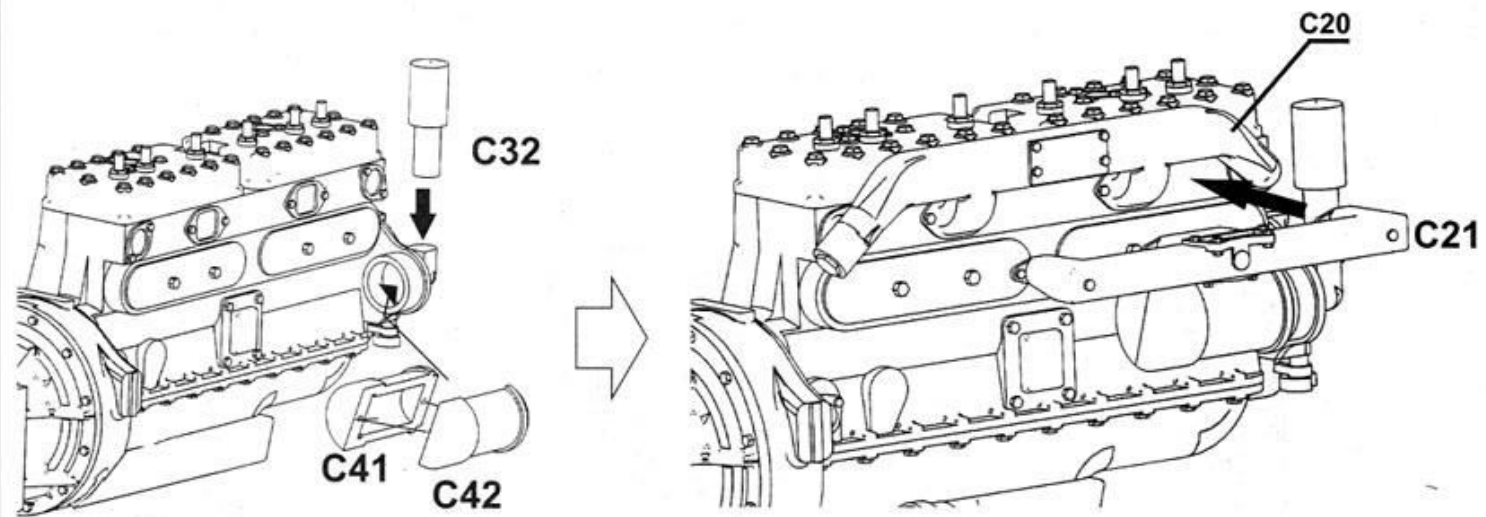
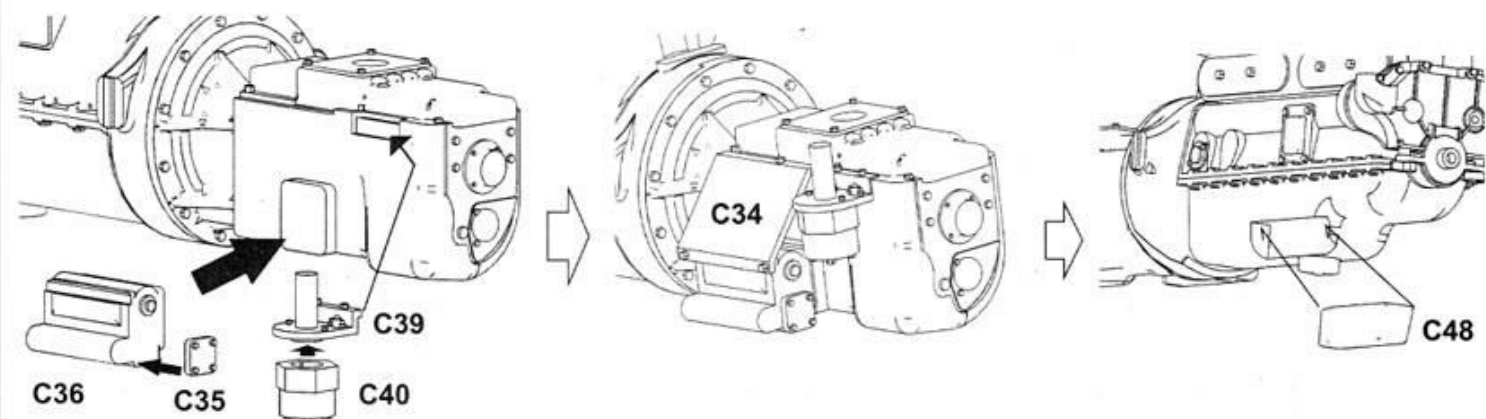
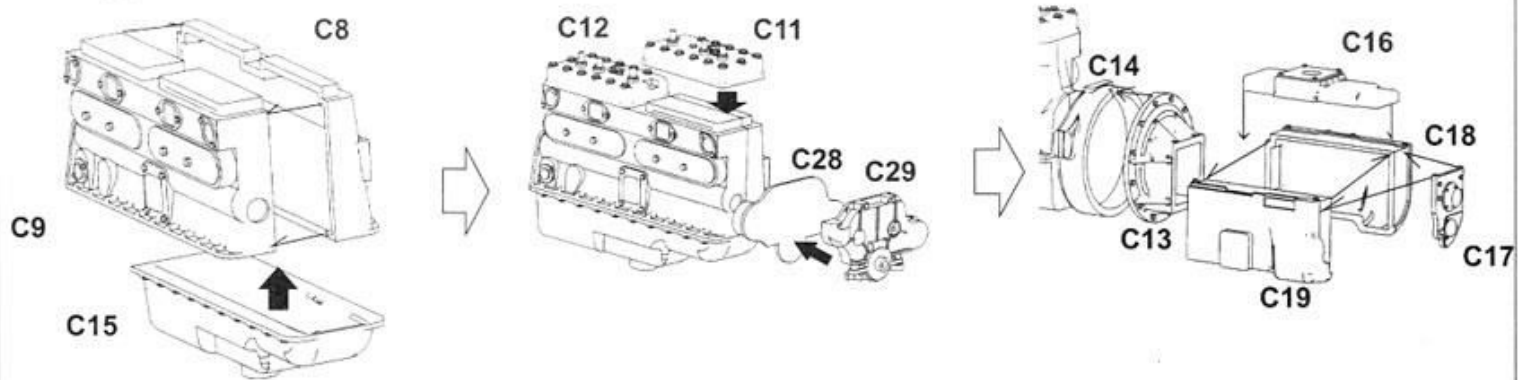

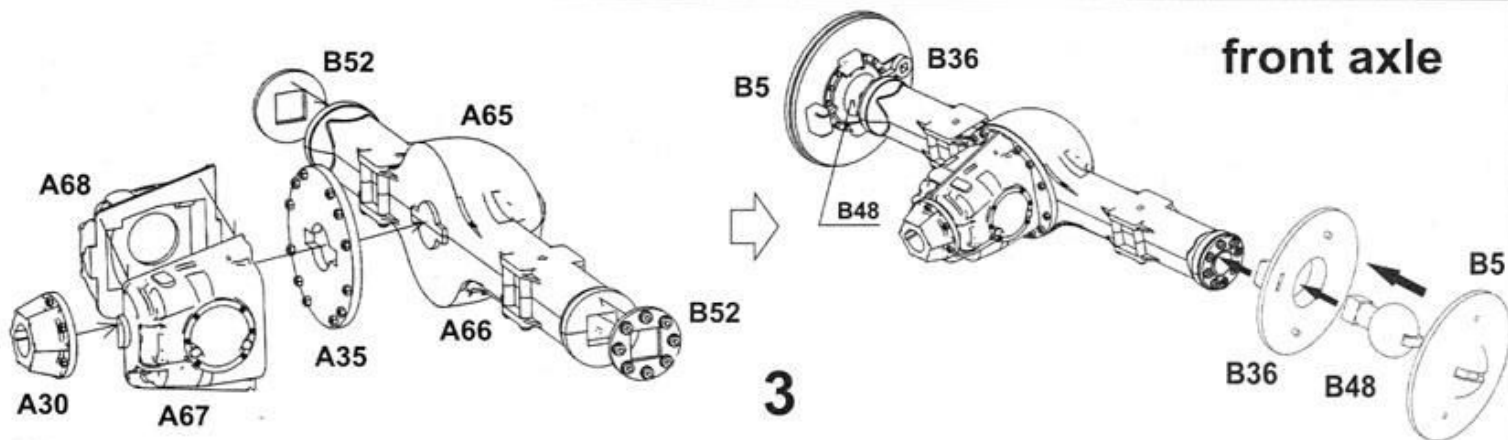
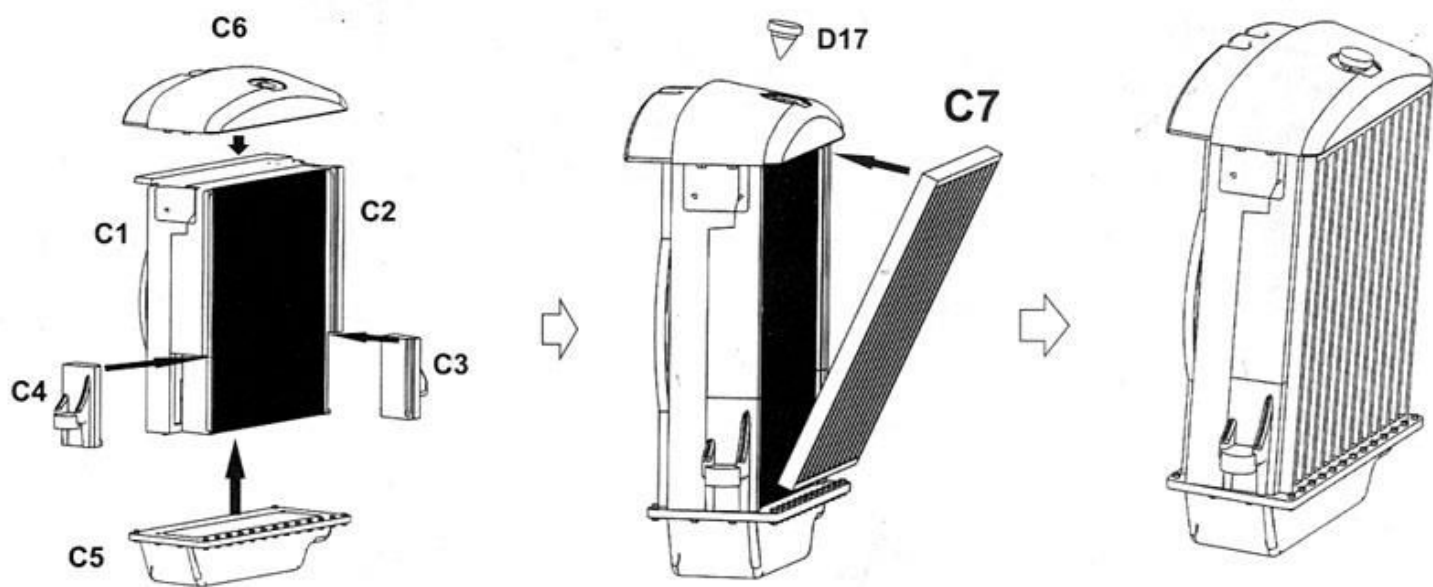
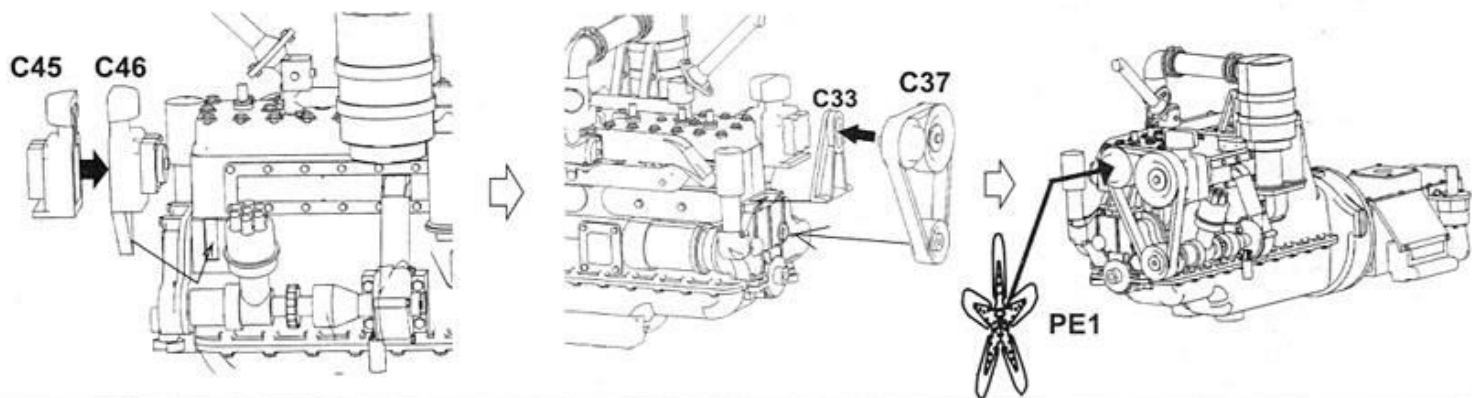
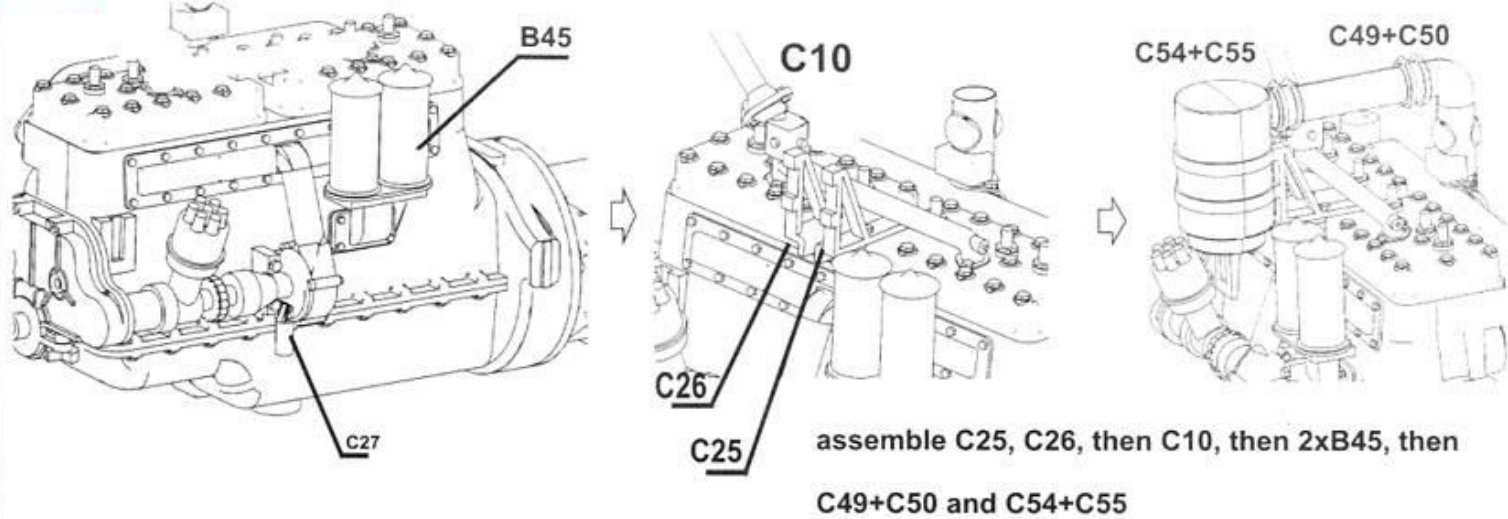

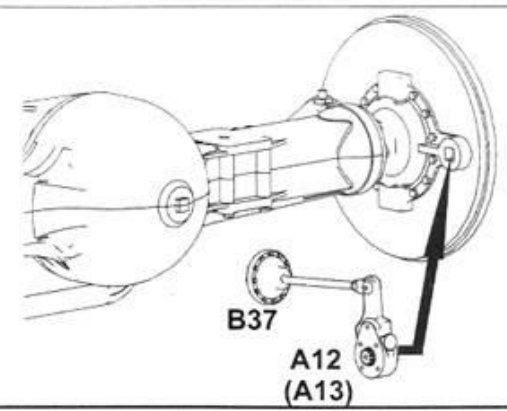
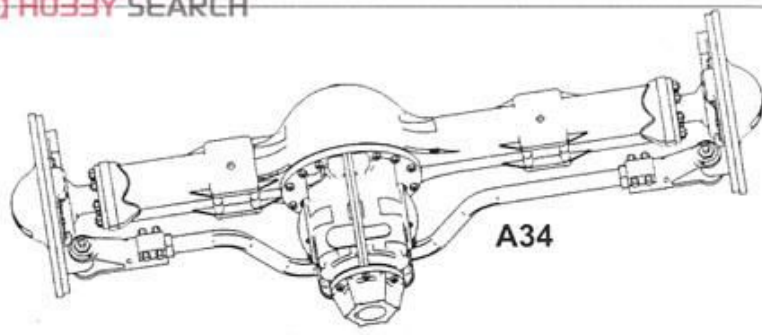

Chassis

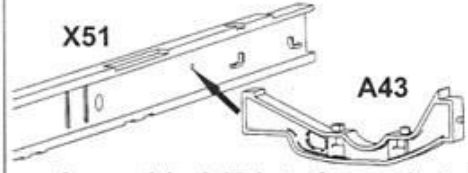

Assemble A43 into frame, but do not glue it until you fit engine later on, you might need to move it slightly forward or back, depending how accurate you have worked on back transmissions, make sure you use X51 and X52 frame parts from dump sprue

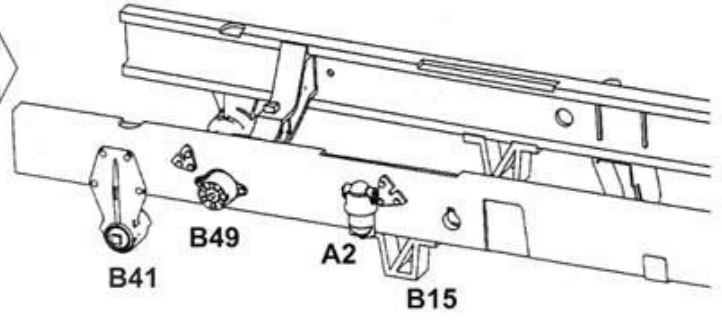
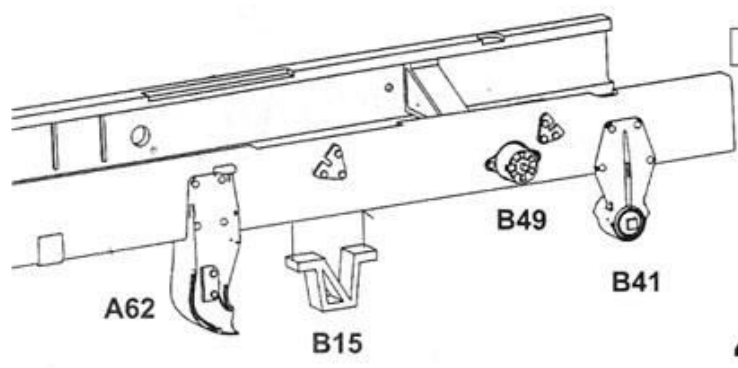
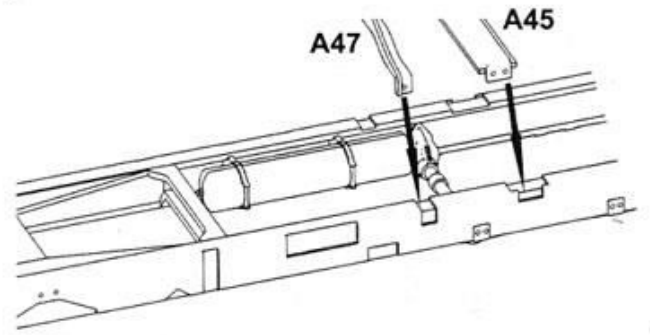
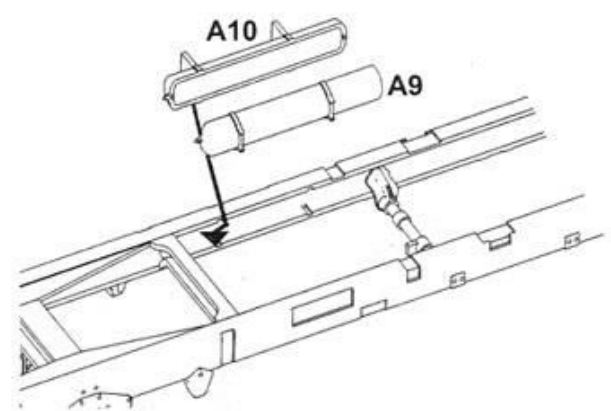
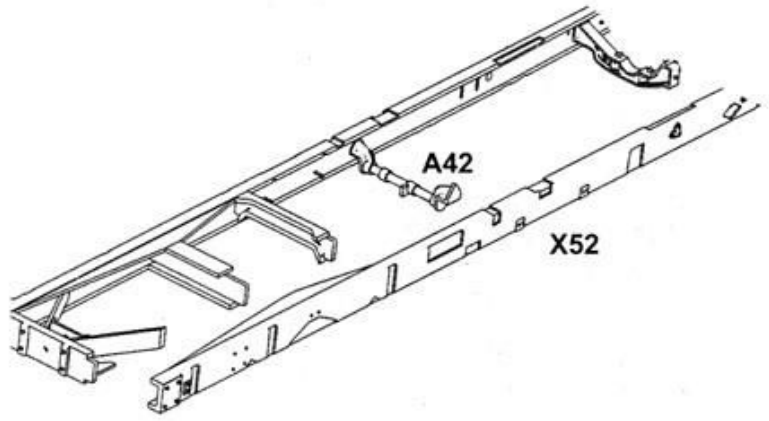
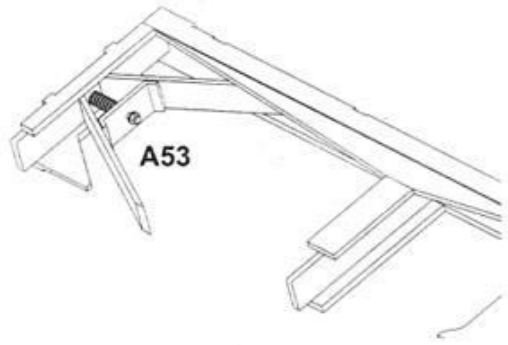
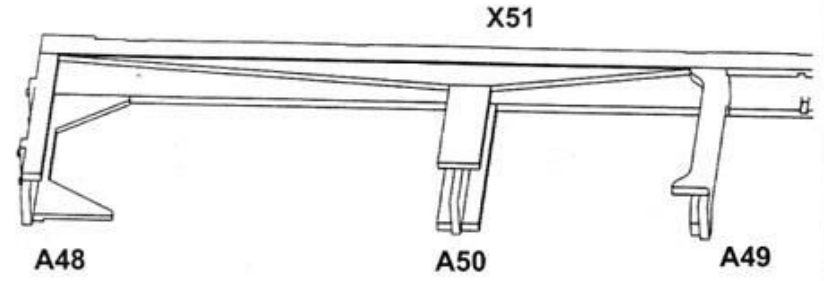

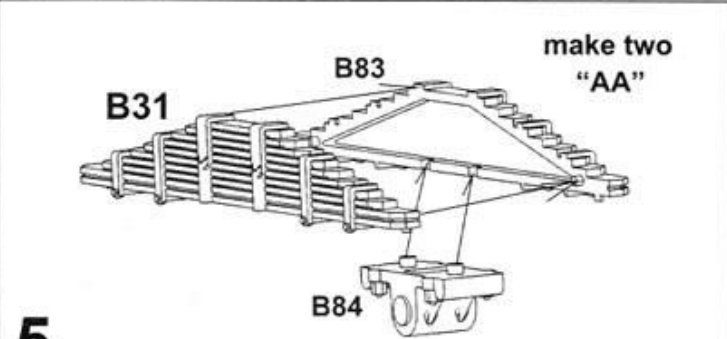
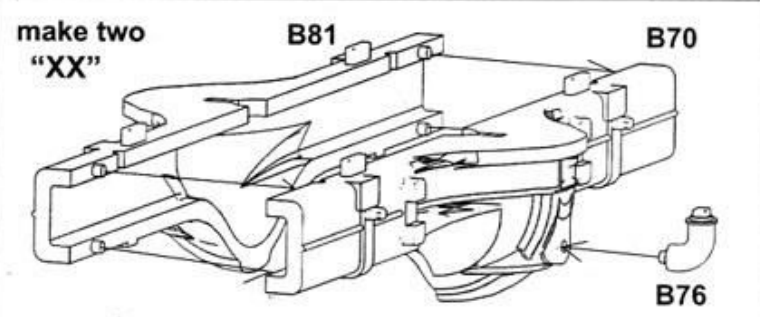
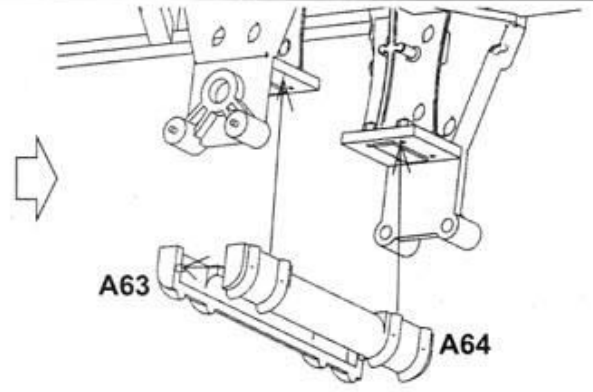
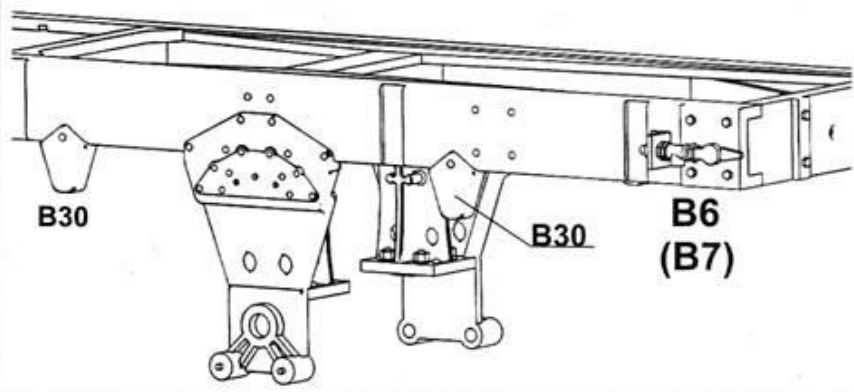
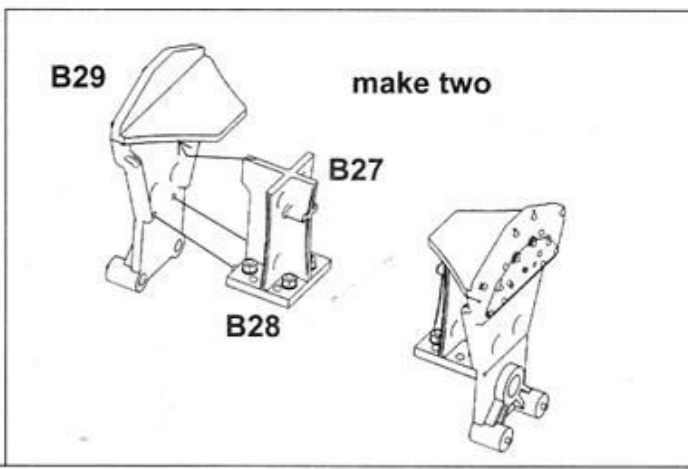
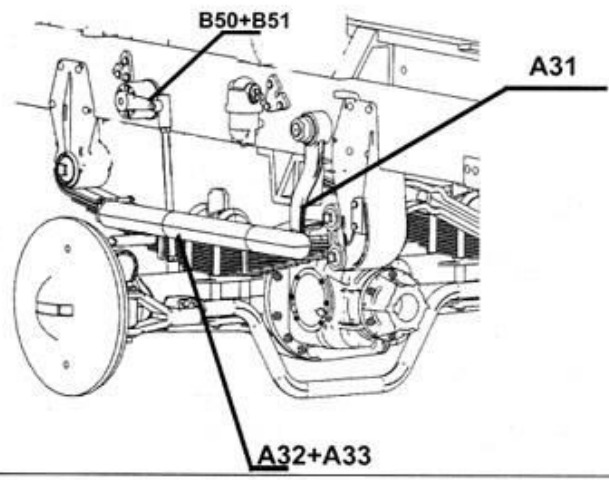
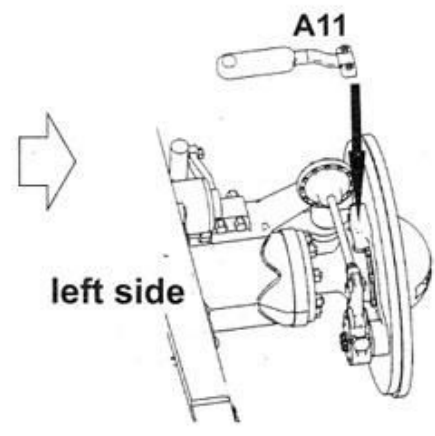
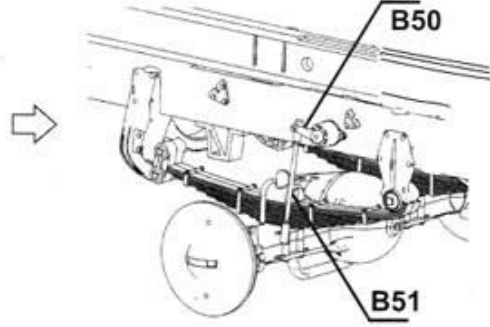
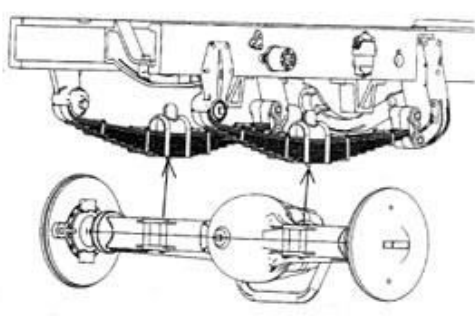
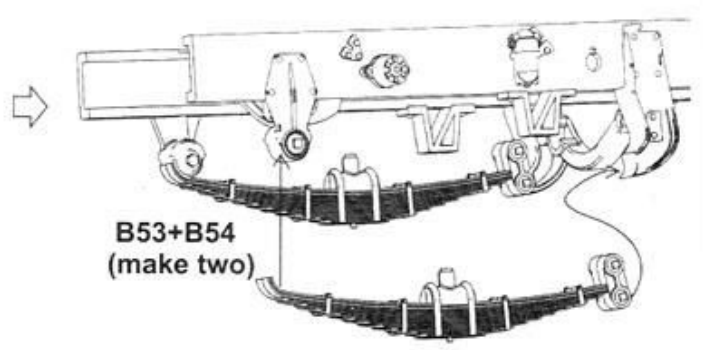
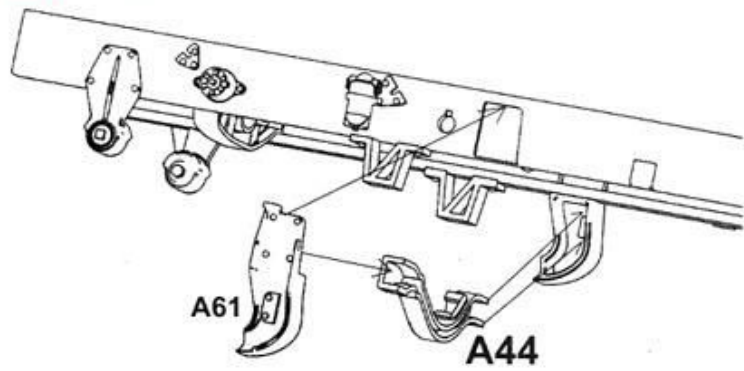

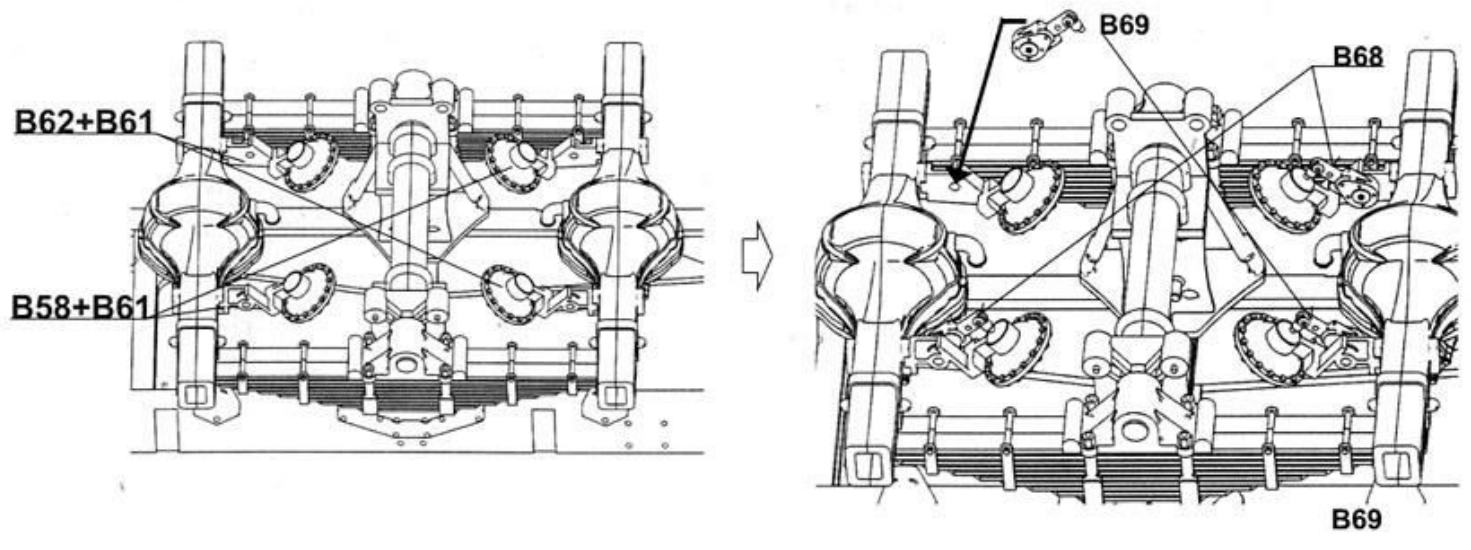
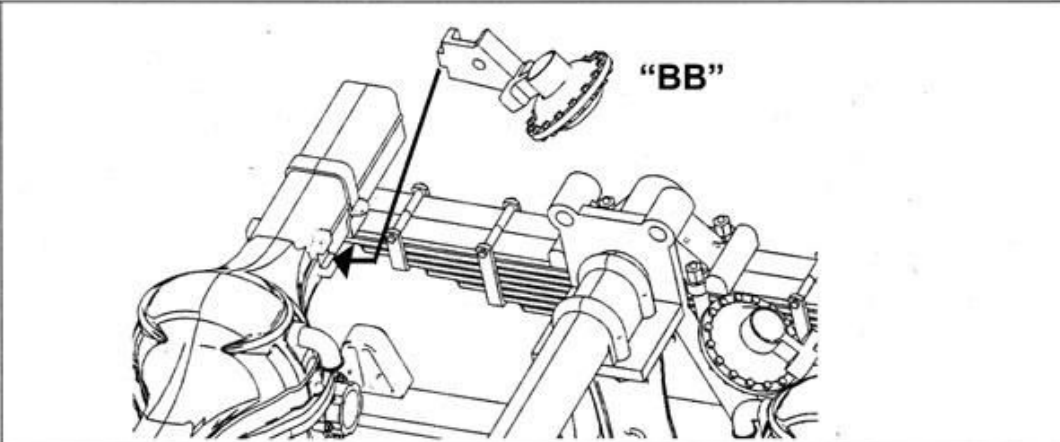
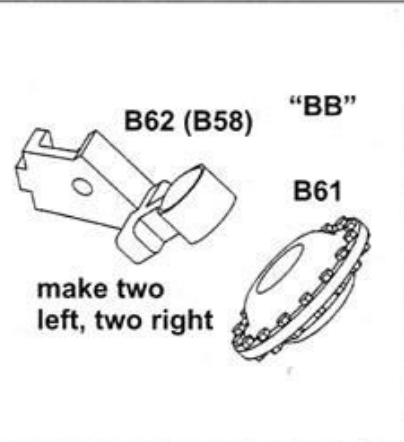
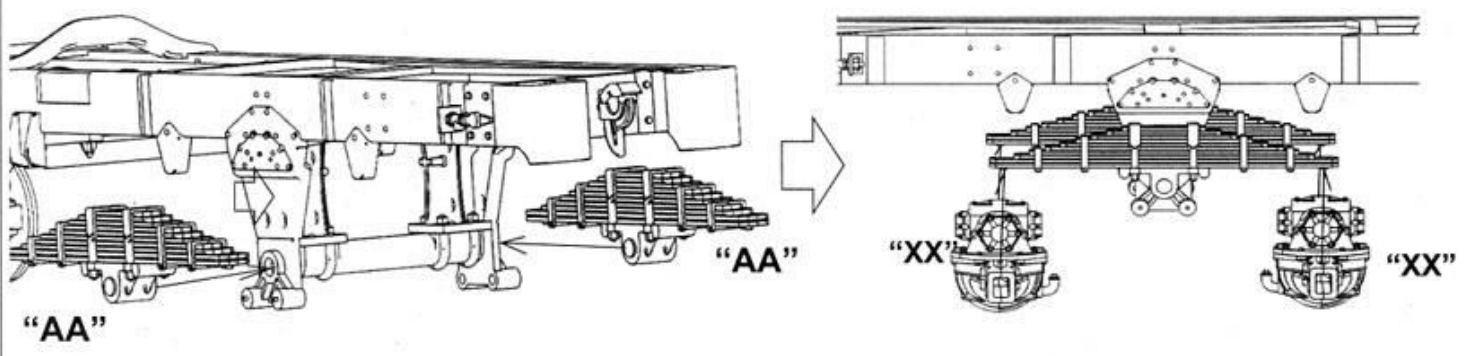
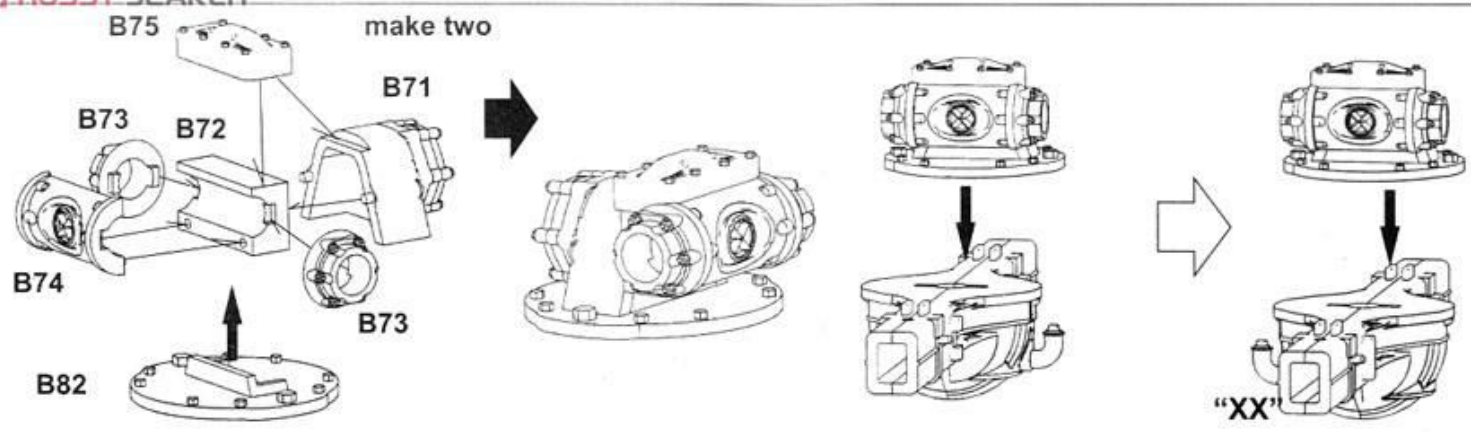

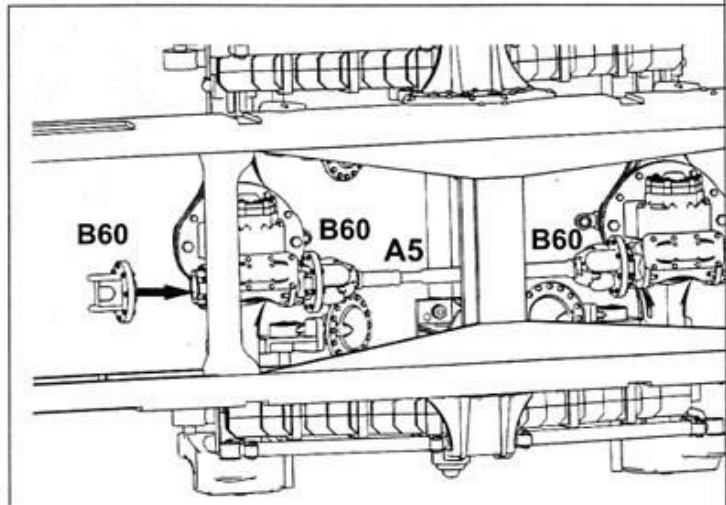
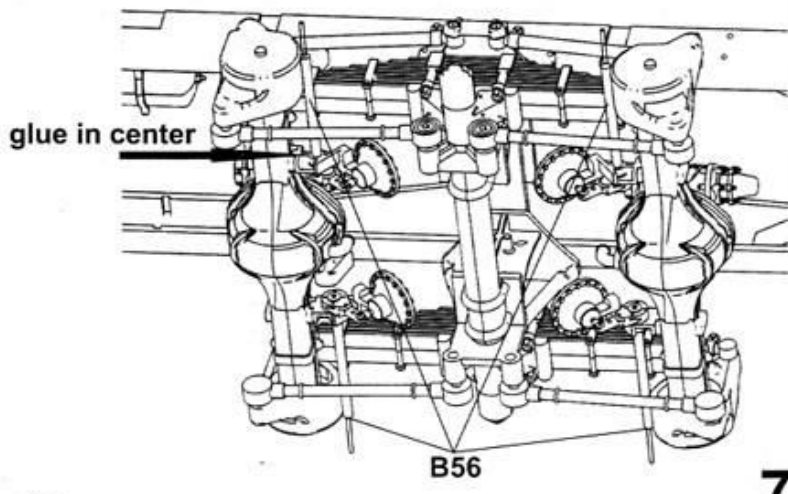
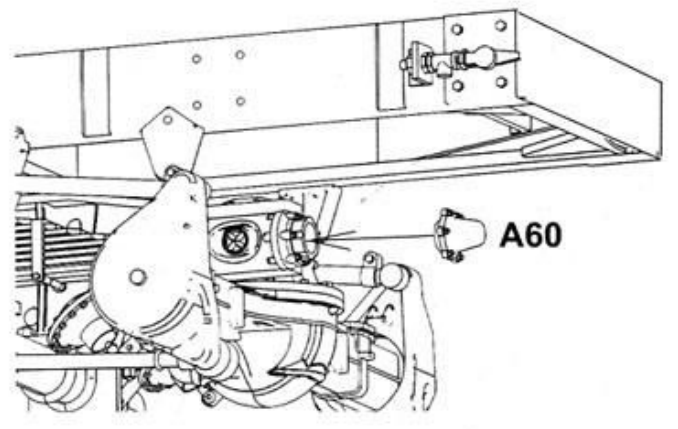
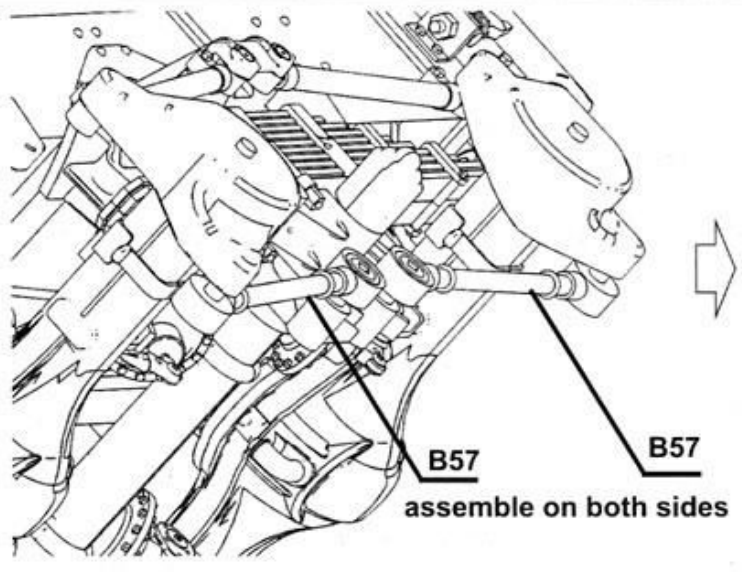
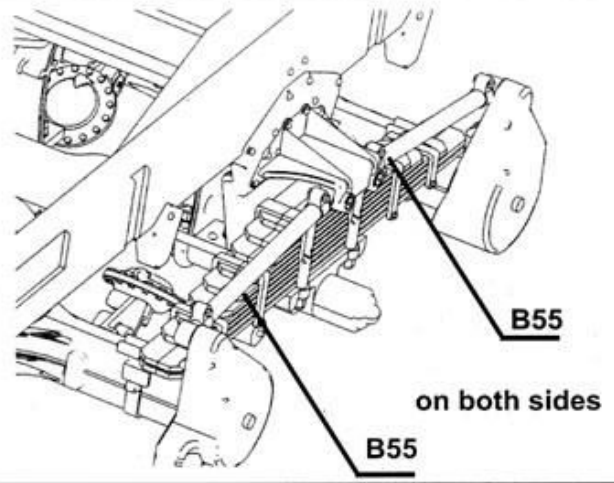
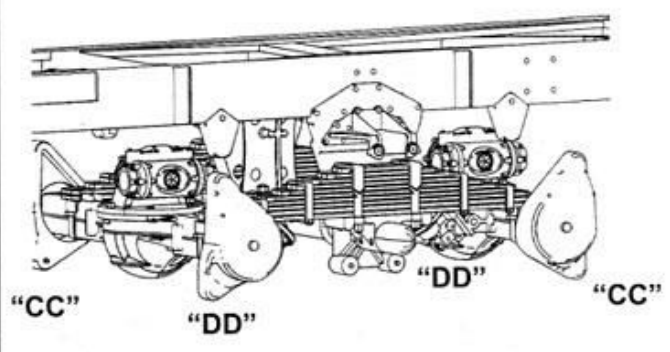
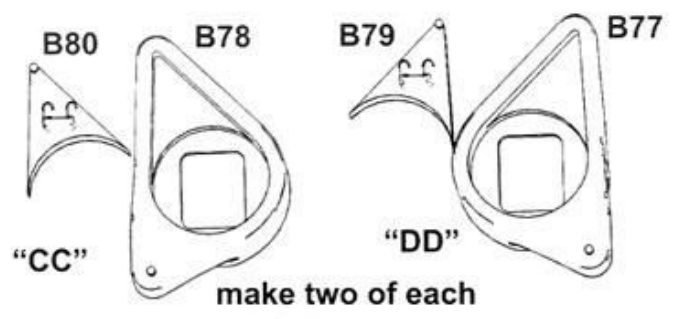
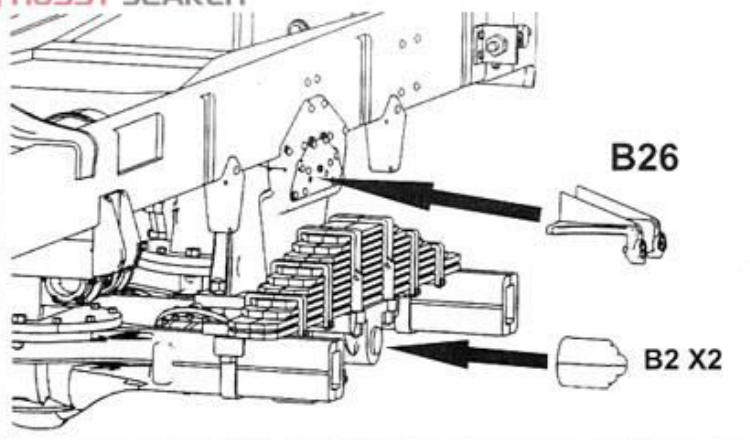

“GG”

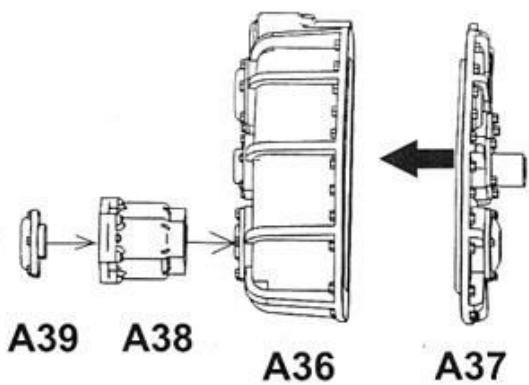

“HH”

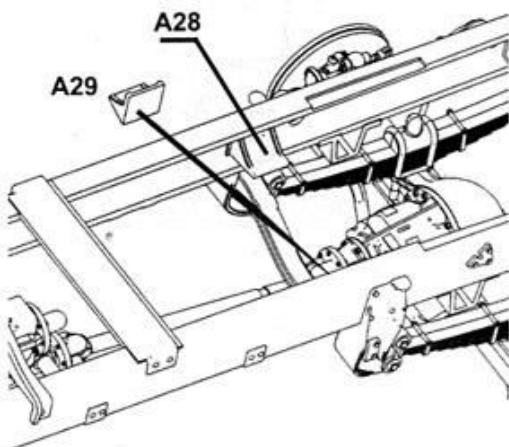
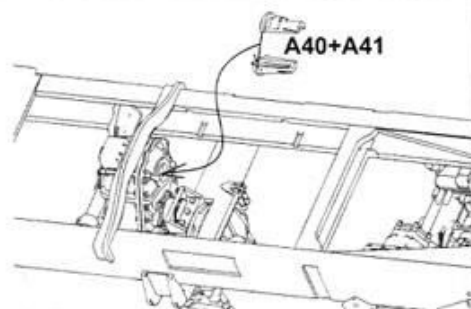
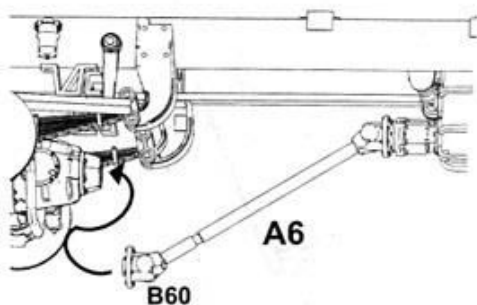
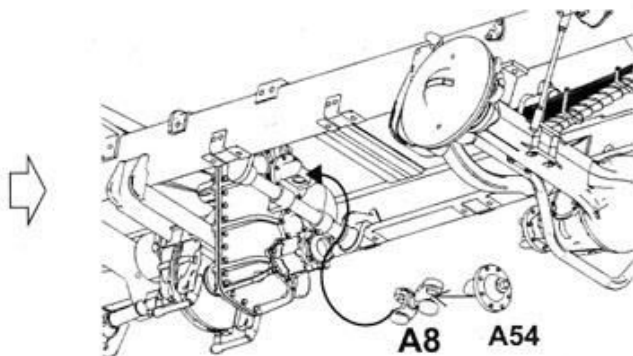
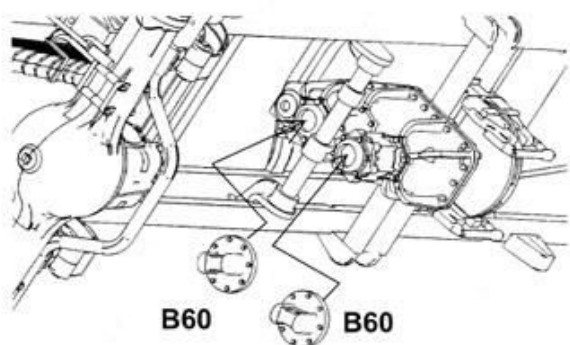
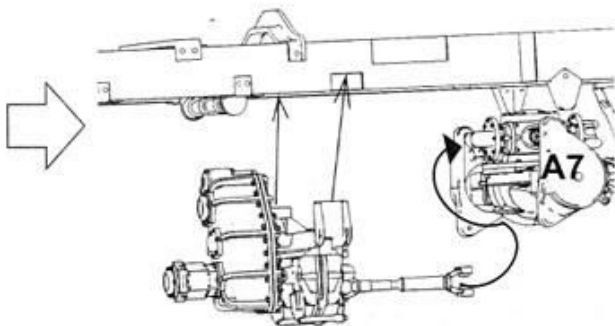
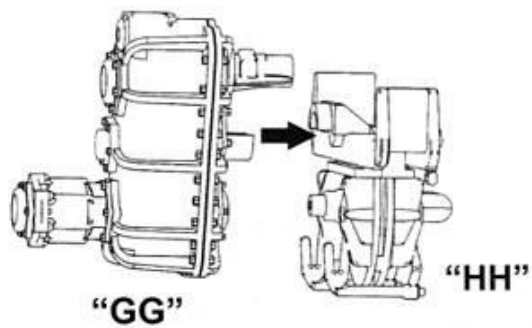
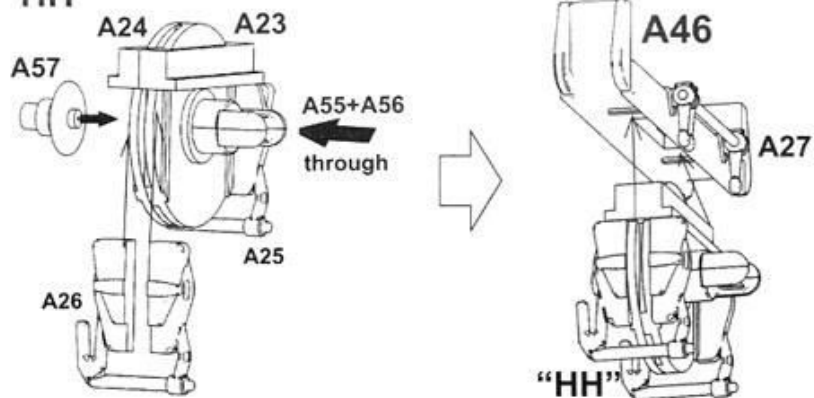

Fit engine at the back first, let it down - if needed, move engine crossbeam A43 slightly front or back and once fitted glue engine and also A43 in position

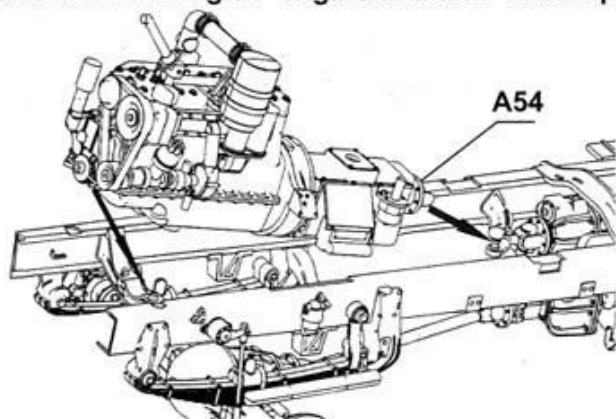

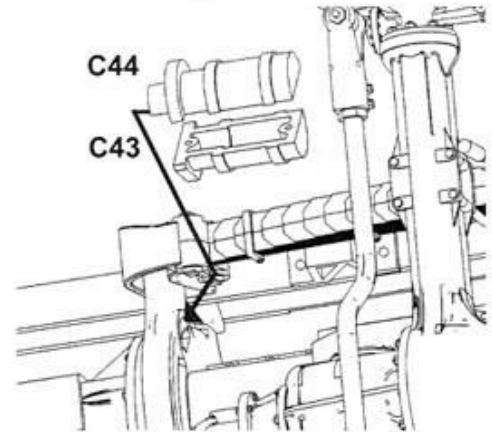
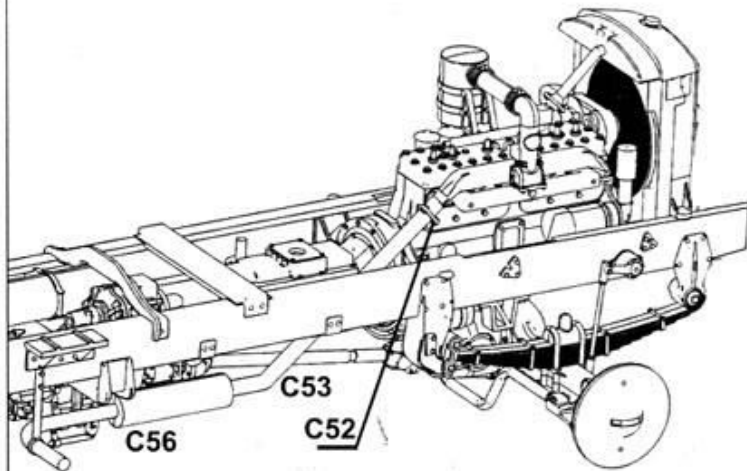
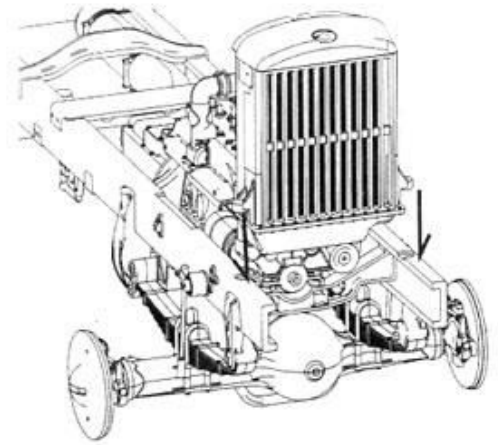
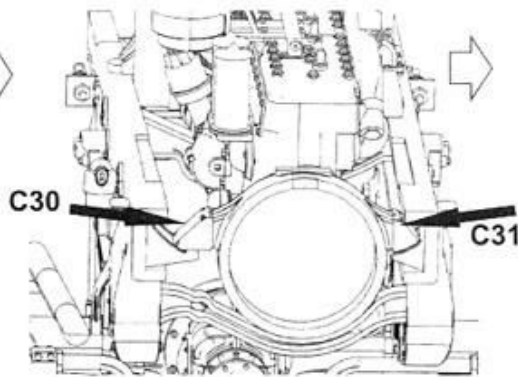
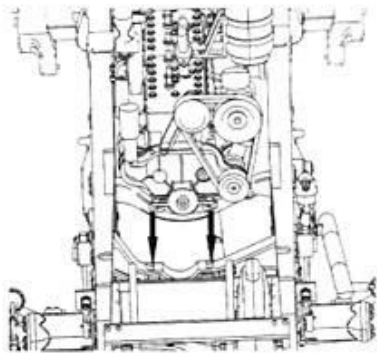

CAB

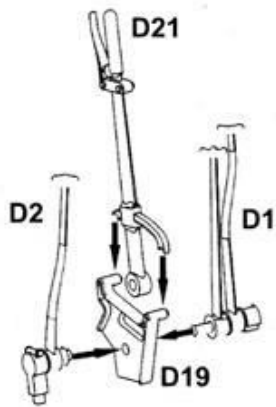

D19+D21 FIRST, THEN D1,D2

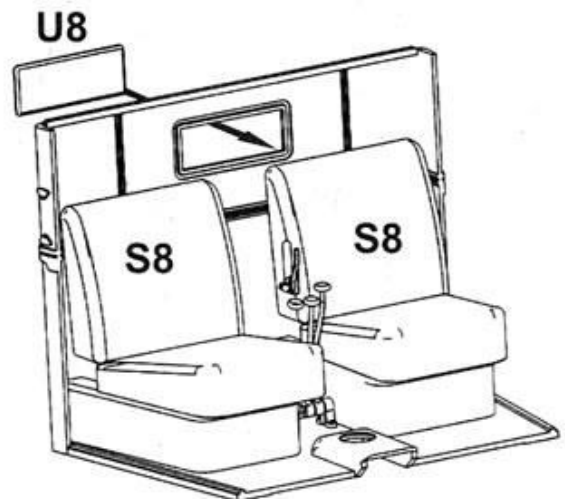
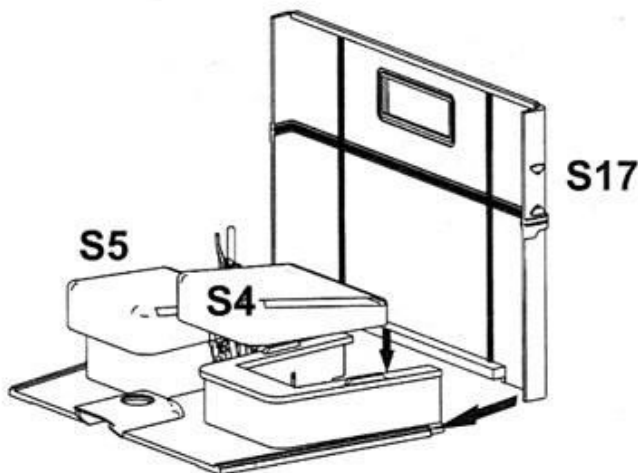
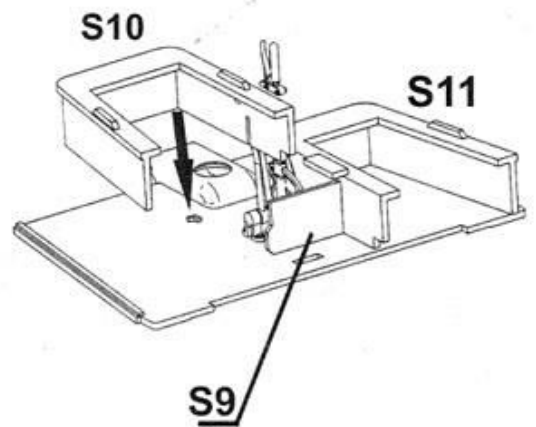
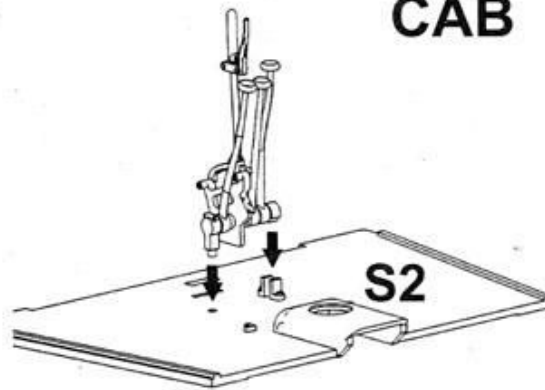

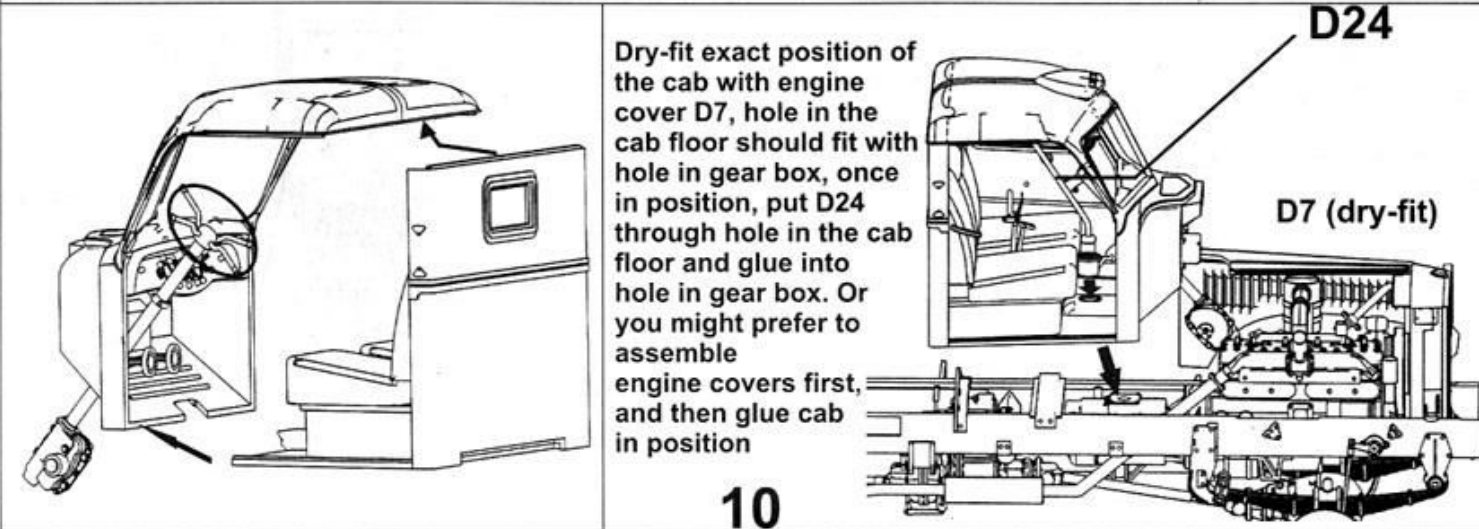
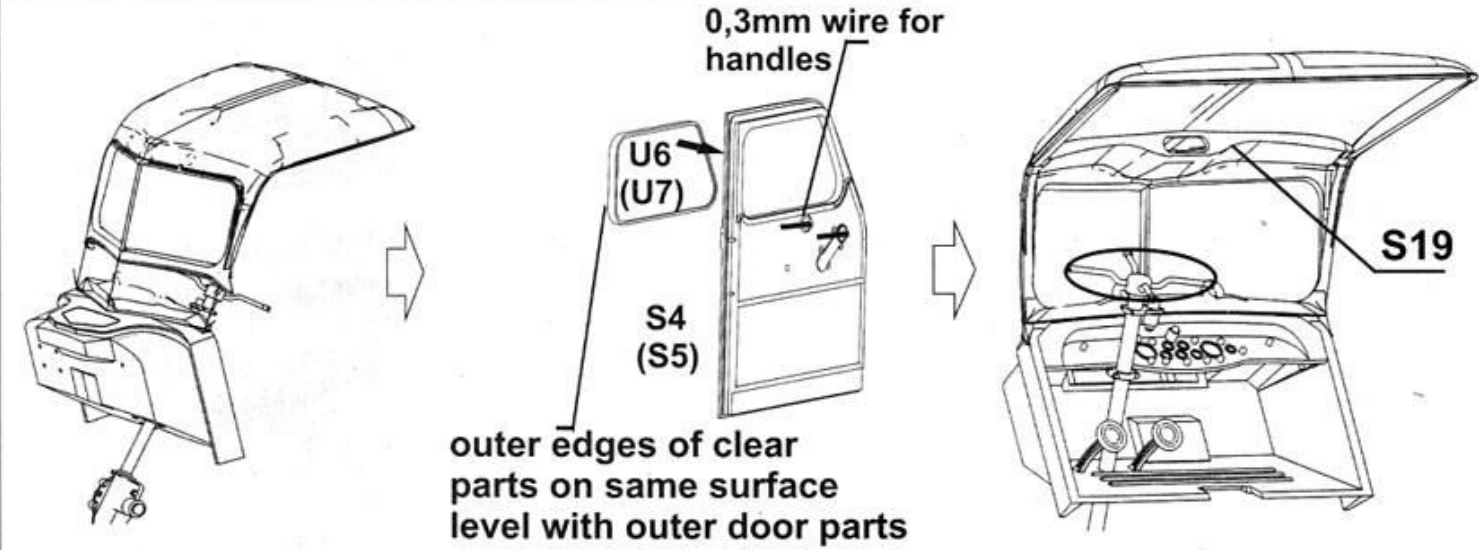
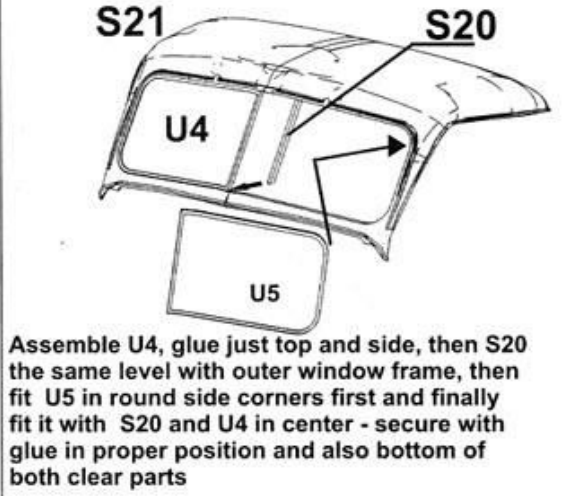
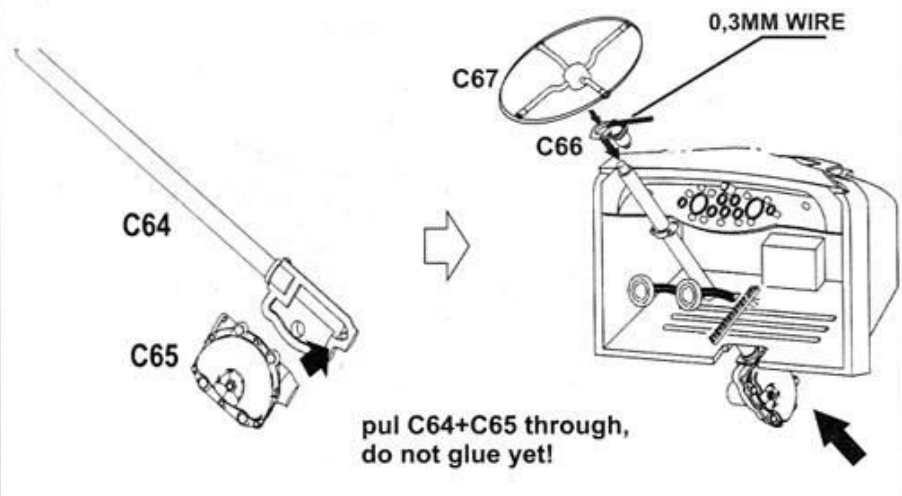
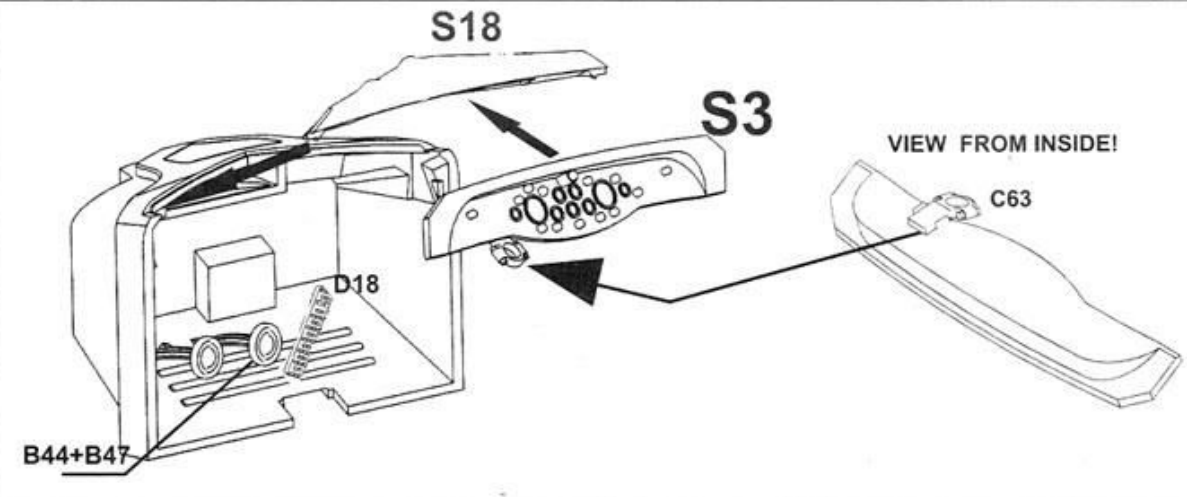

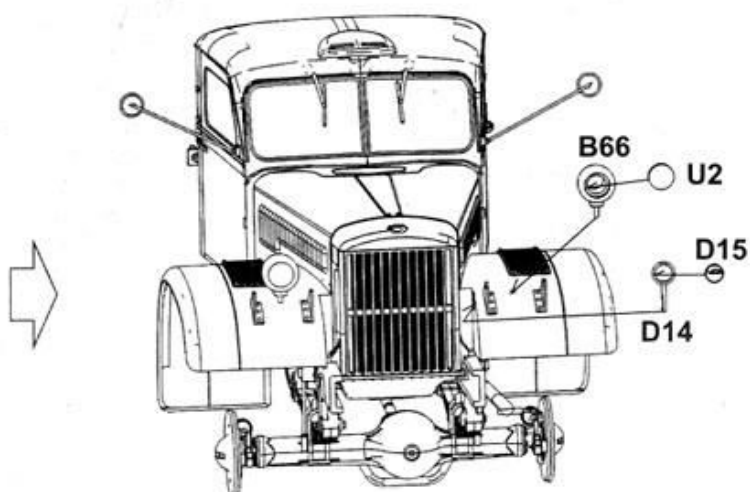
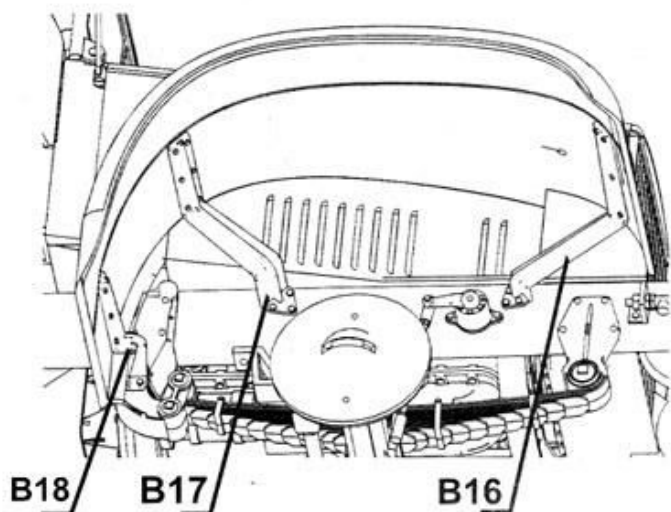
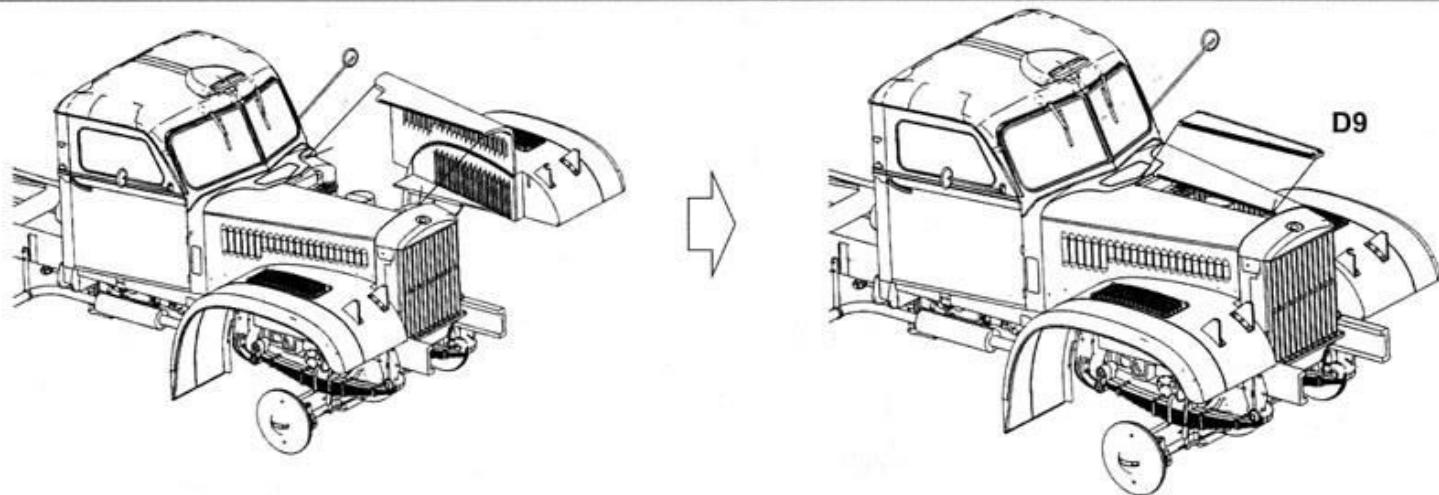
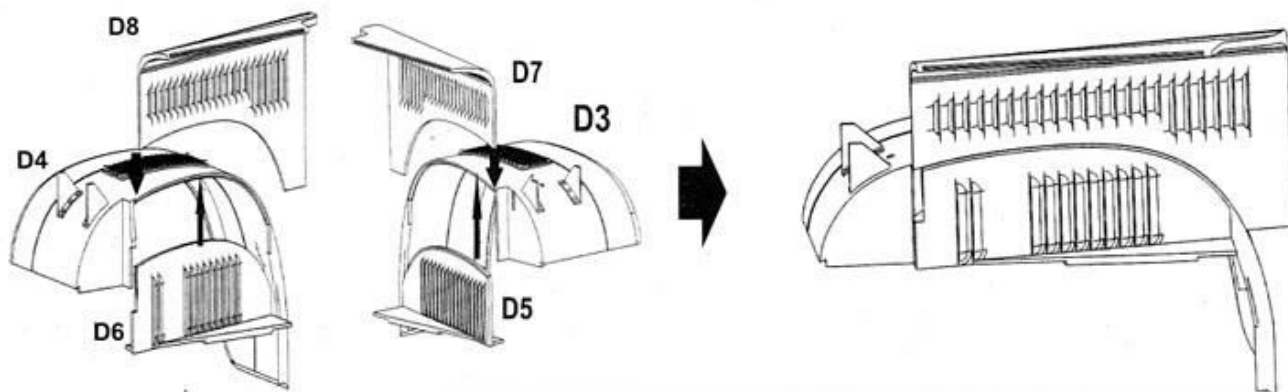
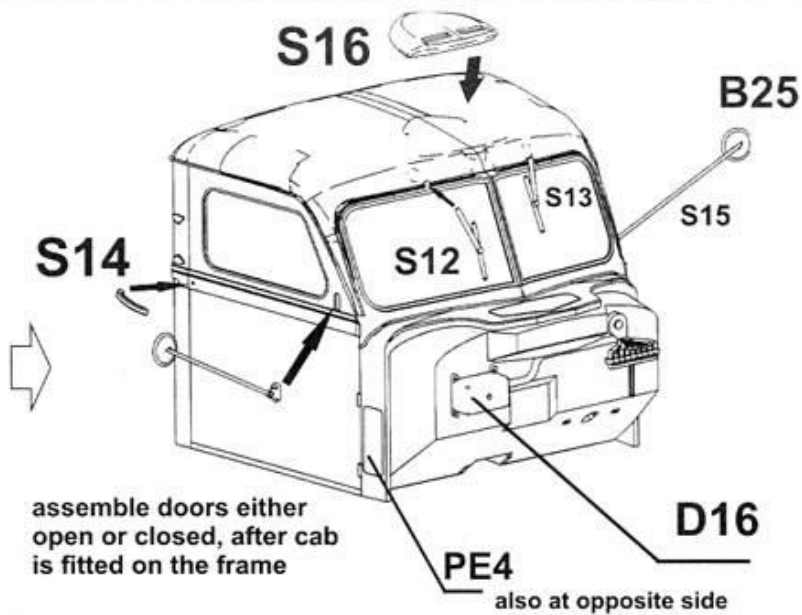
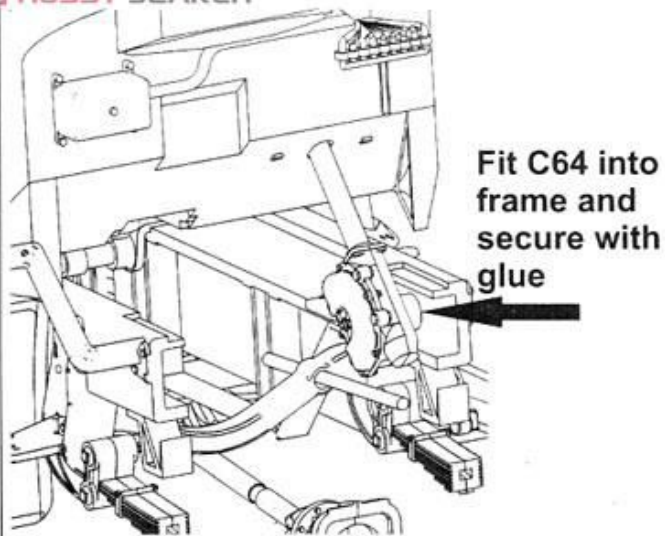

repeat at the other side

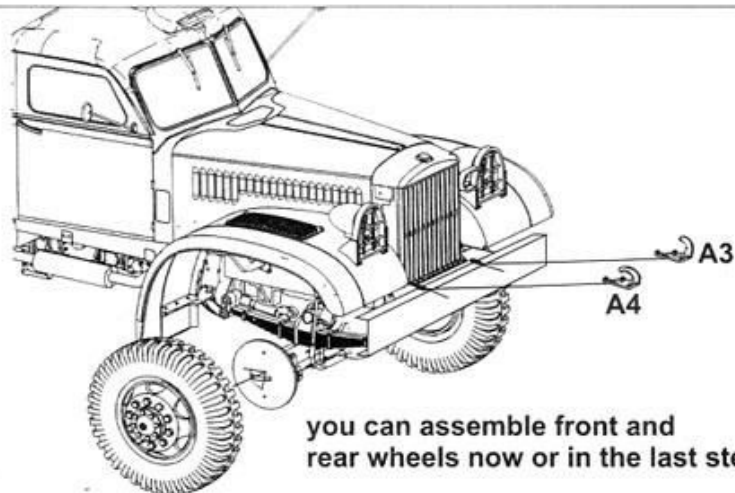
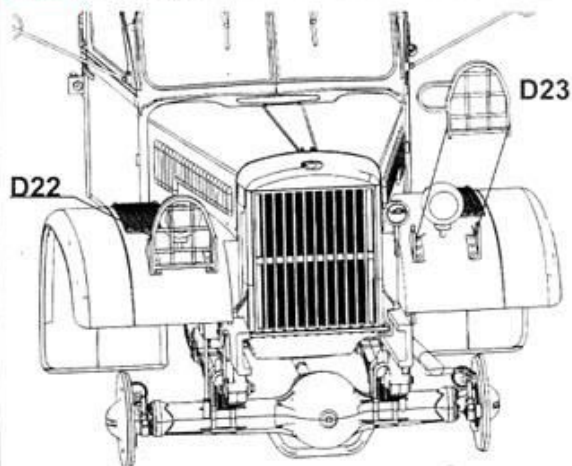

you can assemble front and rear wheels now or in the last step

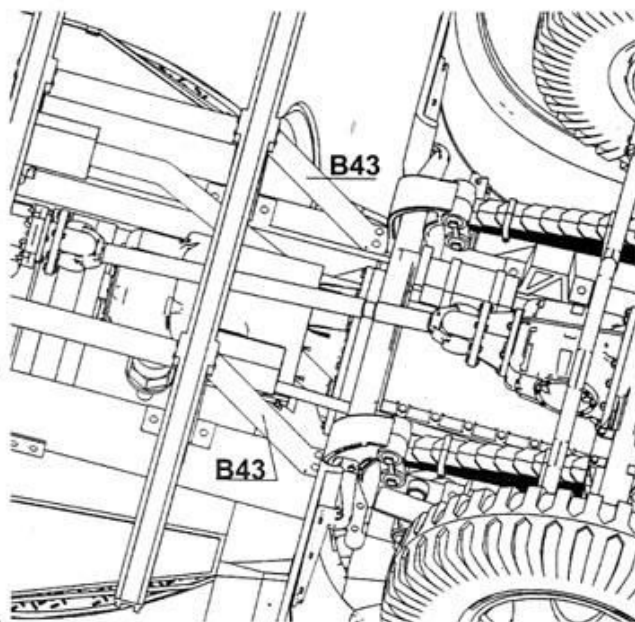
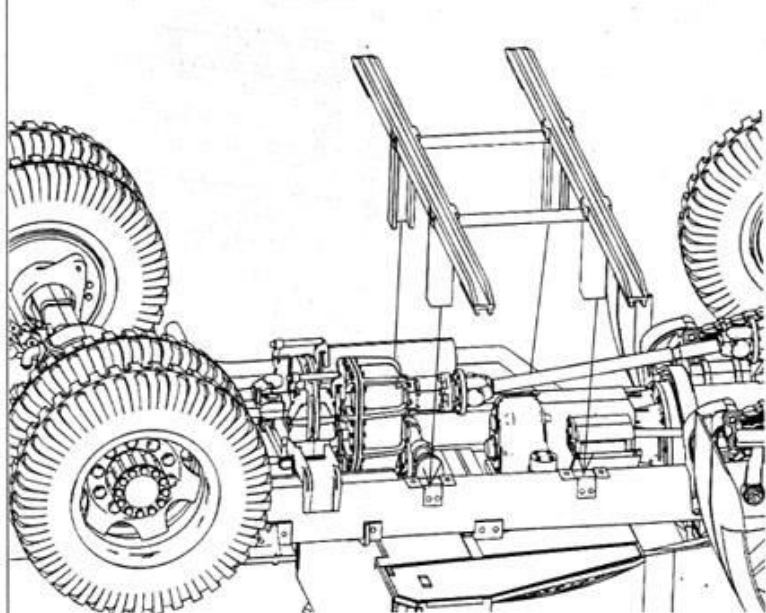
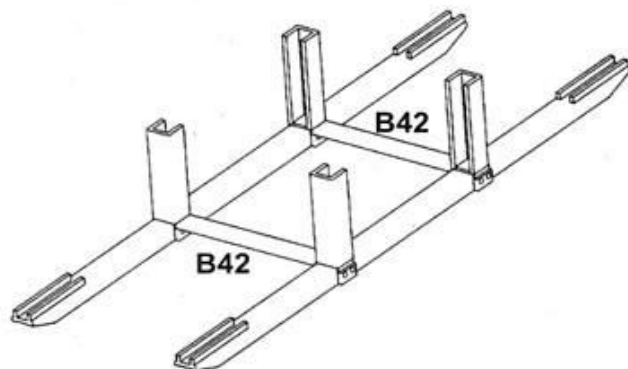
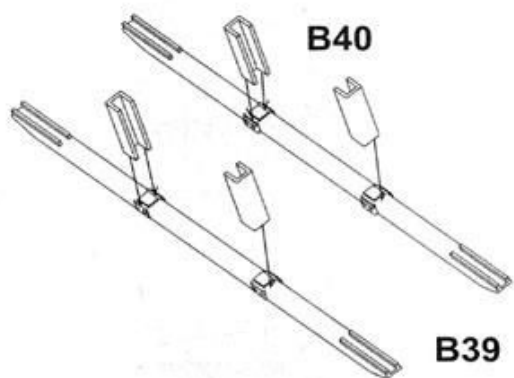
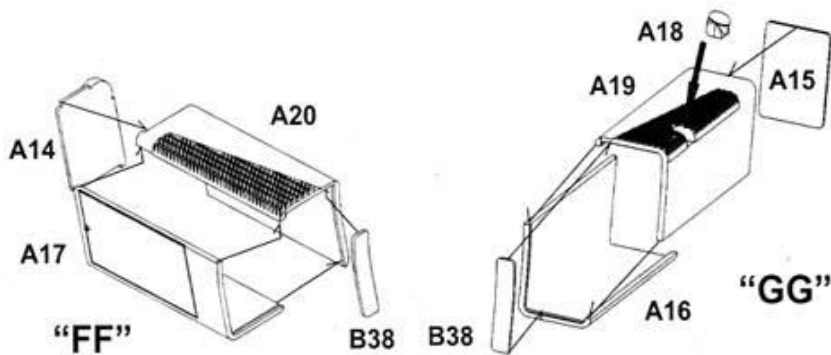
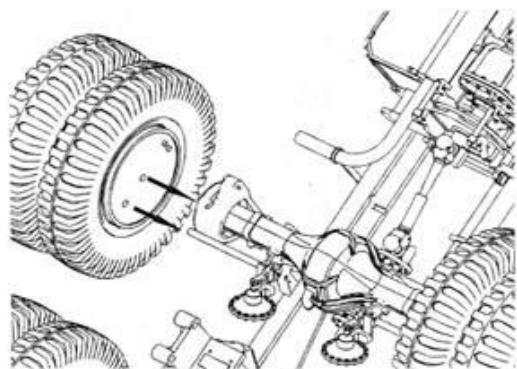

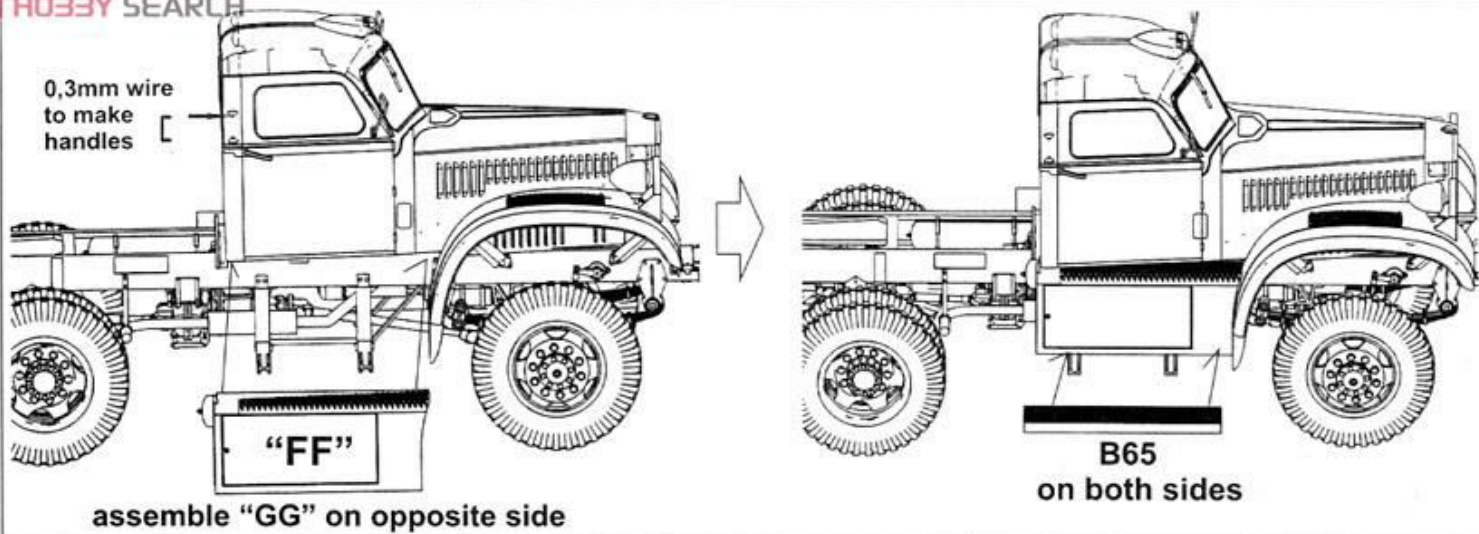

assemble "GG" on opposite side

B65 on both sides

Body

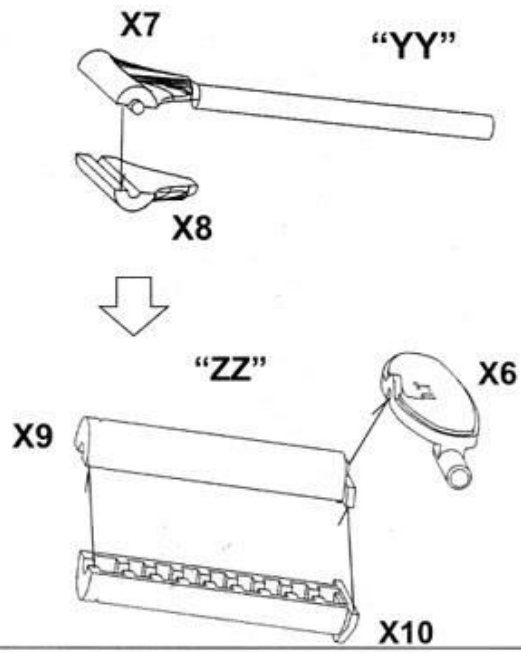
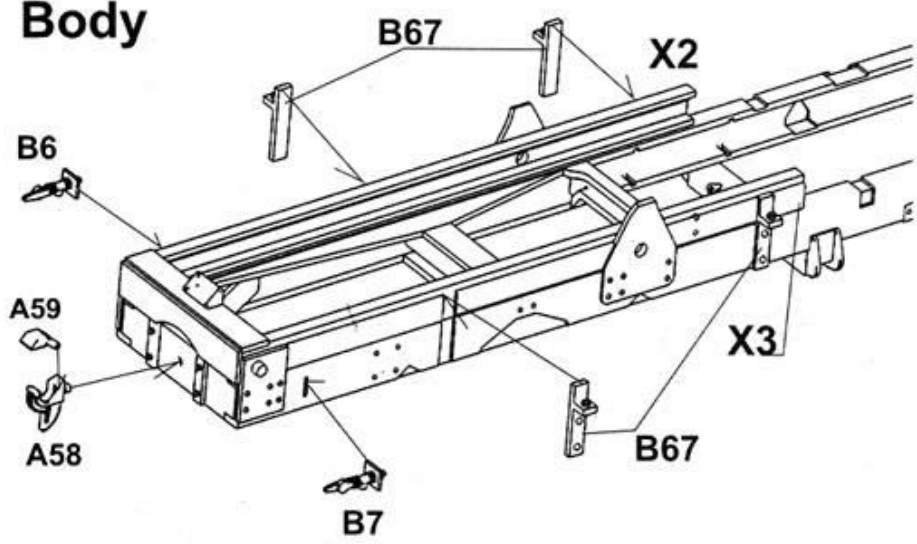

For body in traveling position follow these steps

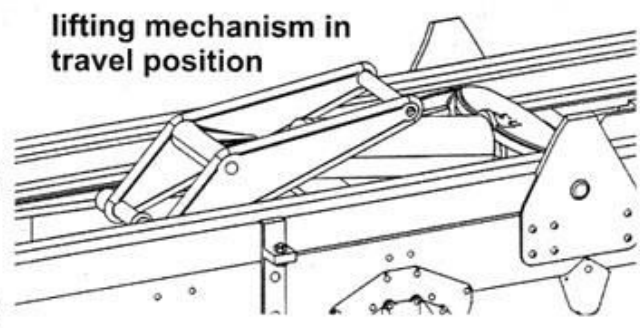
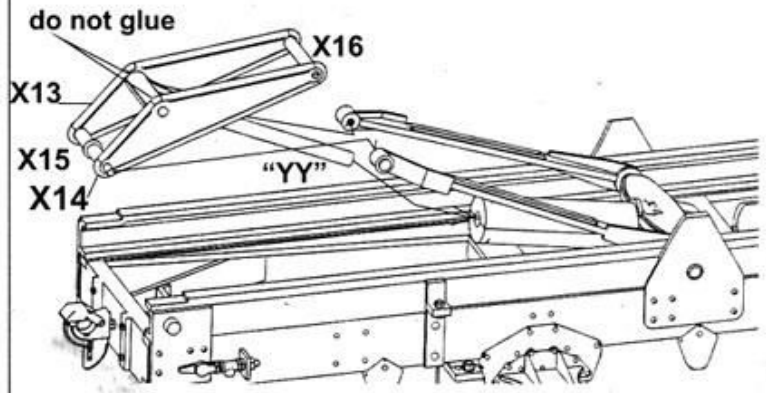
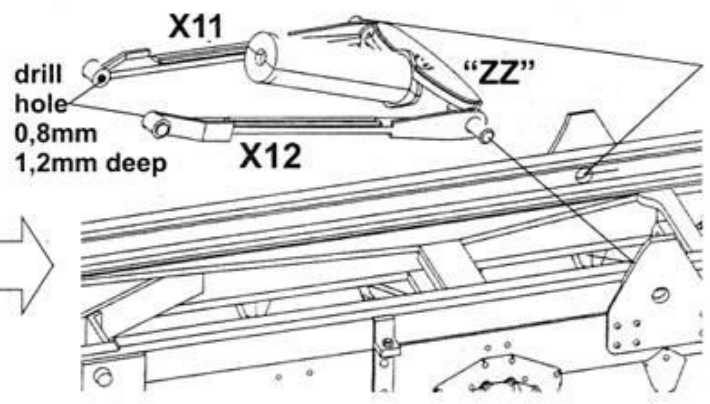
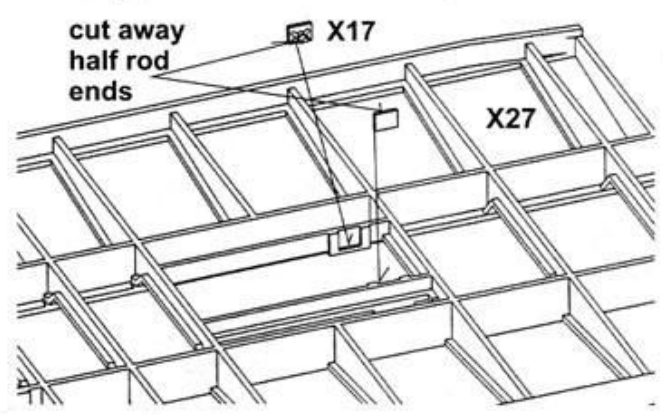

for lifted body follow this step

do not glue

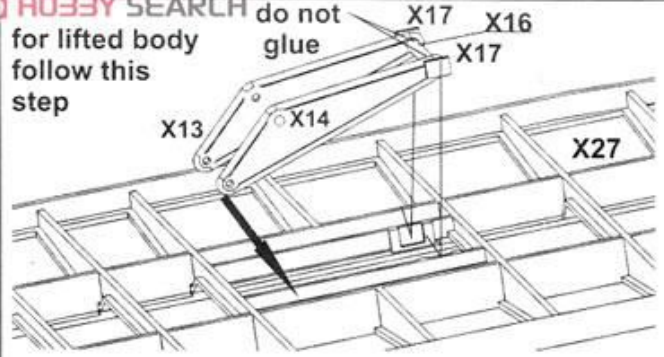

for body lifted insert both X17 into X13 and X14 do not glue, pull arms through opening in X27, while you put both X17 in slots as shown, secure with glue, arms are movable

continue with body assembly

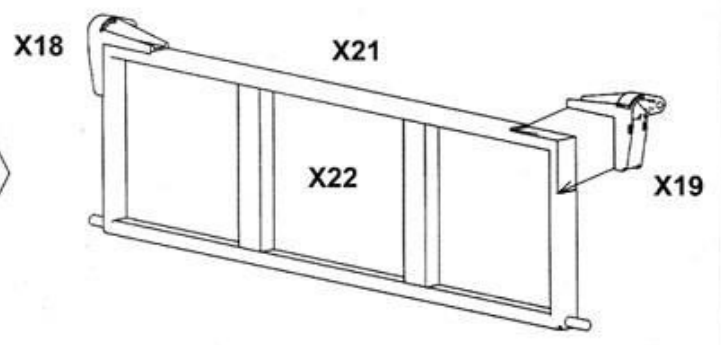
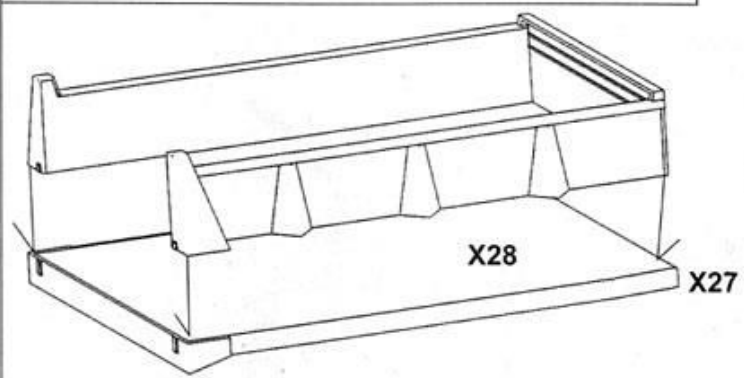
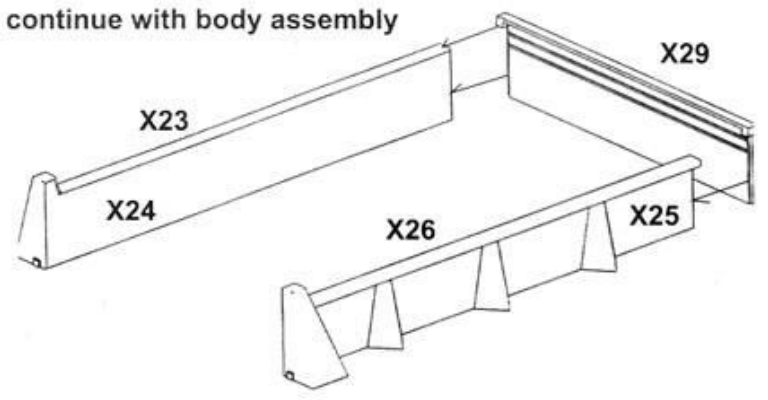

back can open (lifted) or close (traveling)

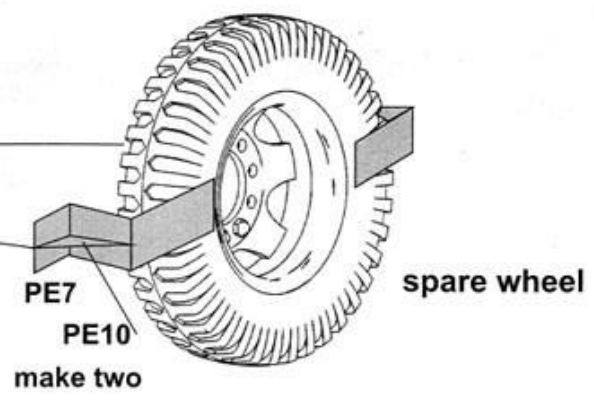
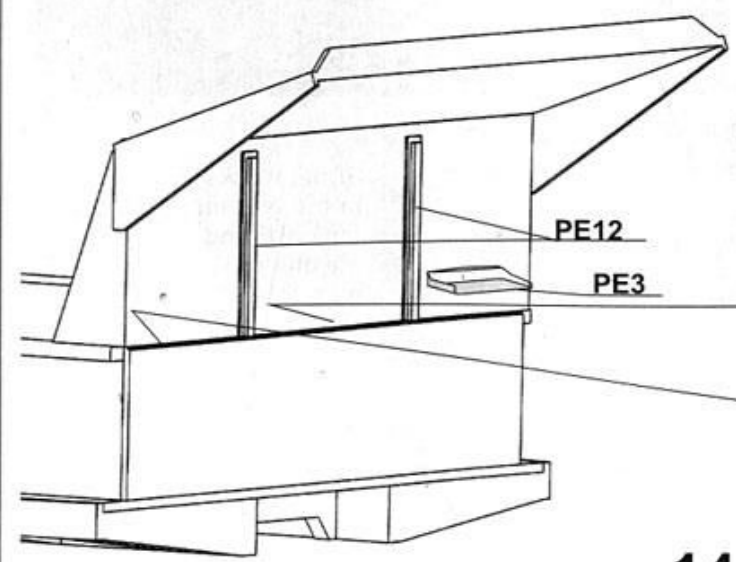
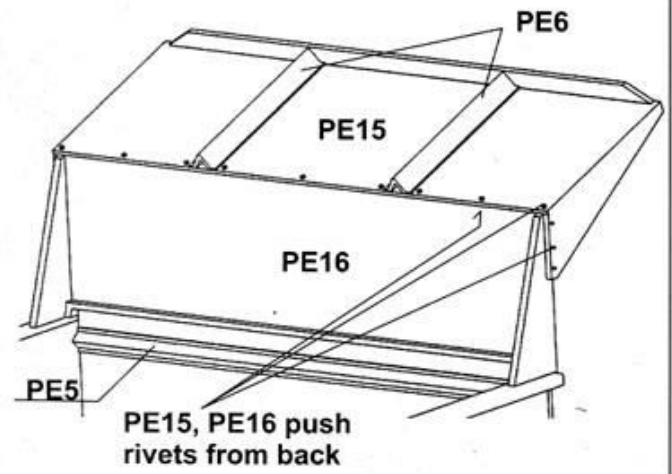
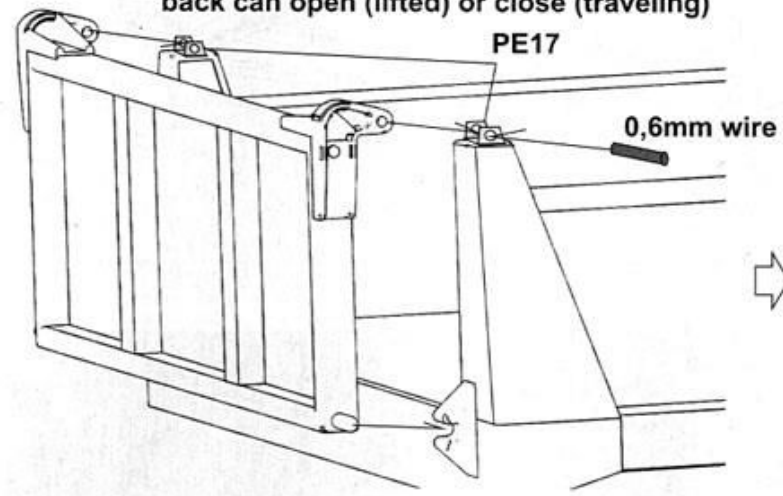

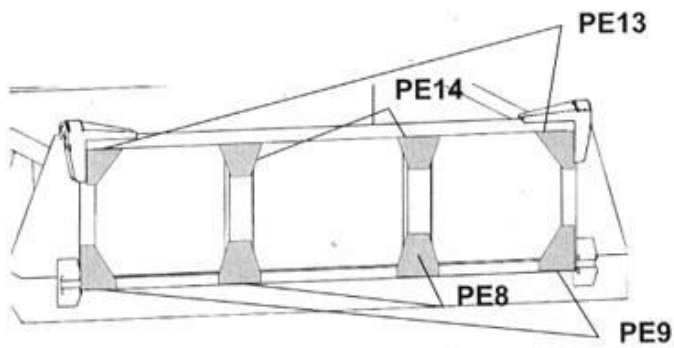

body traveling position

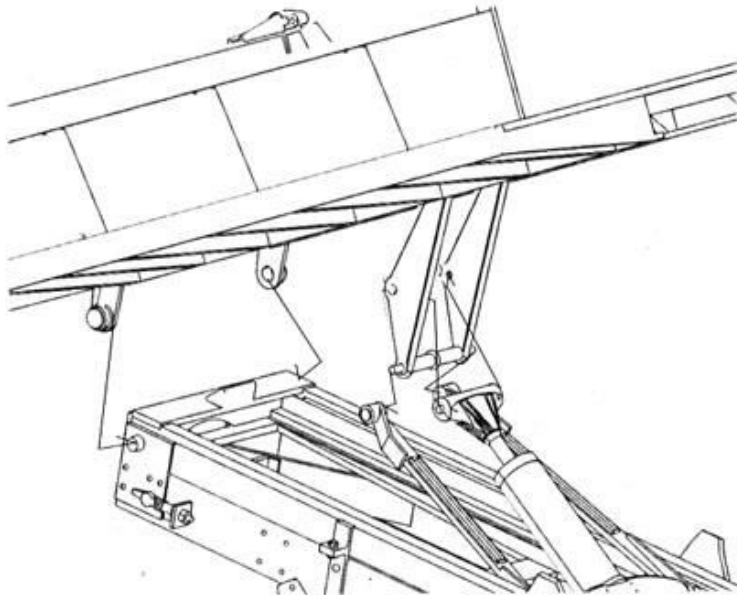
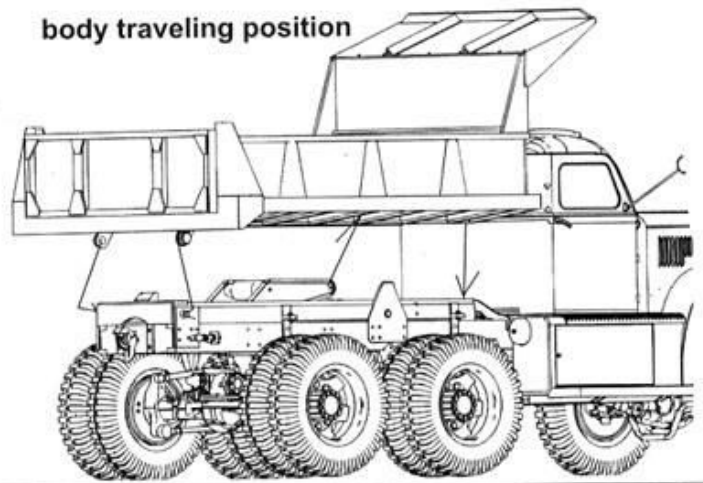

body in lifted position

angle of body has to correspond with angle of arms X13, X14

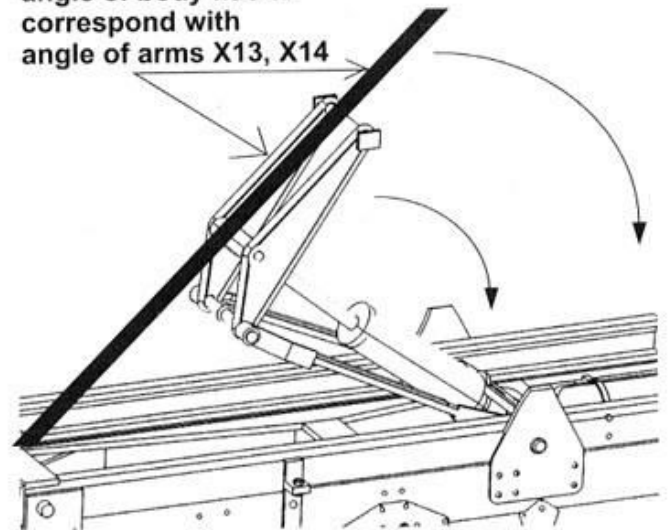

dashboard decal placing

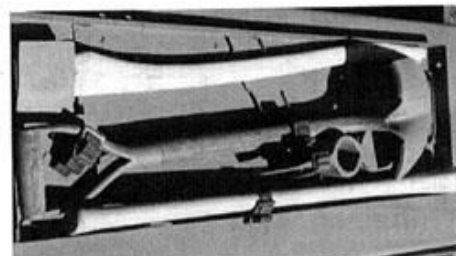
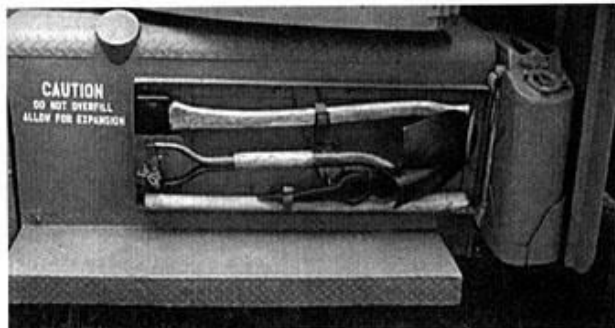
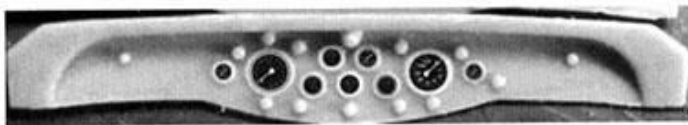

Some trucks had a tool set in the tray mounted on fuel tank, PE and plastic parts for this option are supplied with the kit

B32, B33
B34, B59 - tool parts, PE7 - tray + PE belts

If you have experienced missing or damaged part, contact us directly for replacement at info@mirror-models.com
Additional PE detail set (to replace various kit plastic parts with true to scale sheet metal), upgrade resin wheels and much more available from LZ Models at www.LZmodels.com



Diamond T 972 Dump Truck



Painting and Marking Guide

A.MIG 111 SCC 2

A.MIG 033 Rubber & Tires

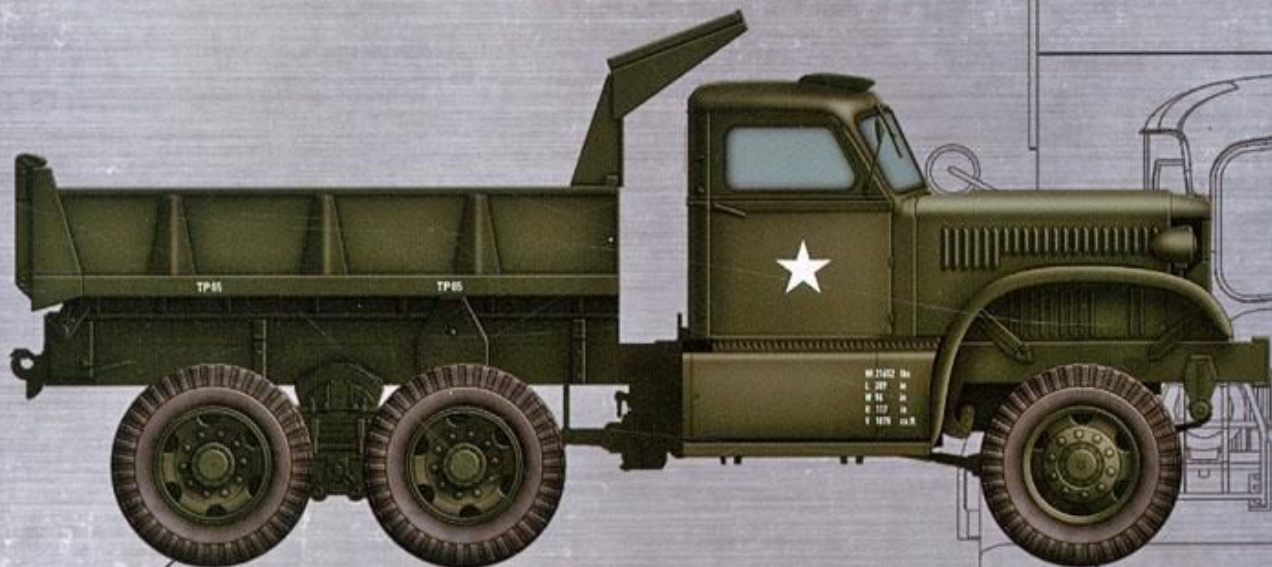

A.MIG 033

① OR ③

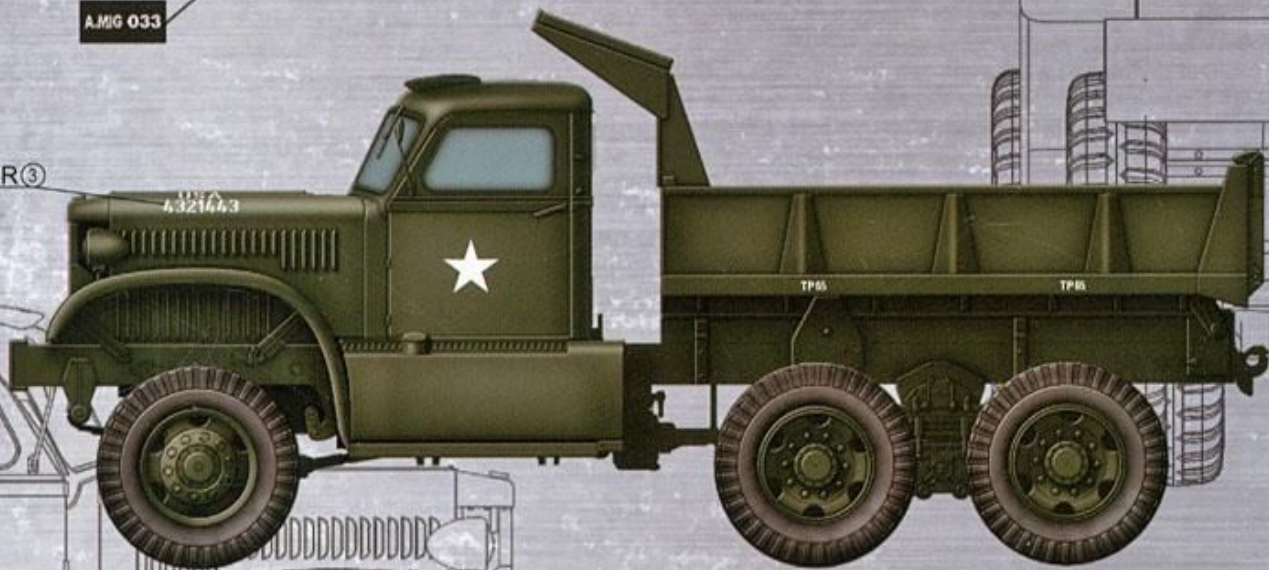

⑤



④

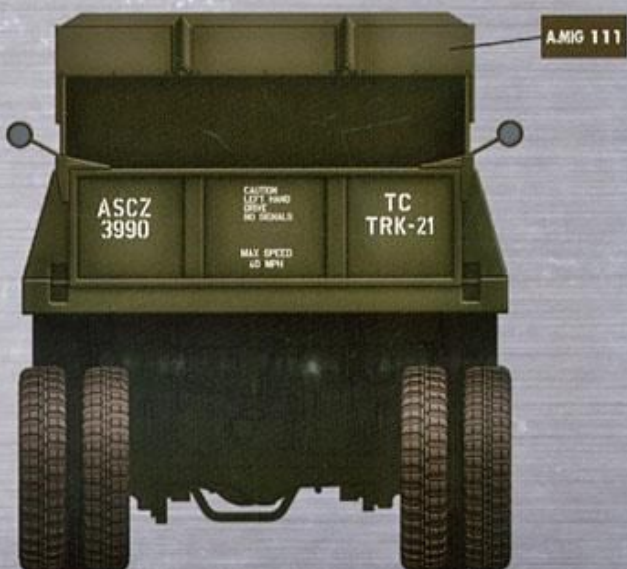



A.MIG 033

A.MIG 033

A.MIG 032

A.MIG 103

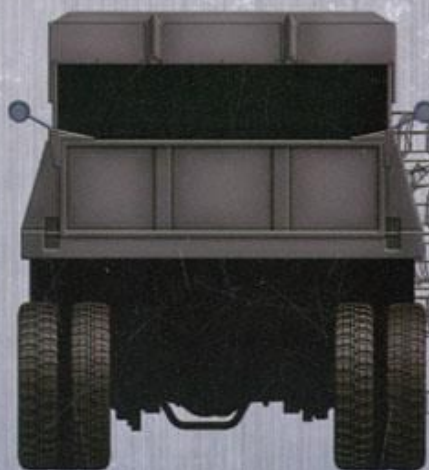
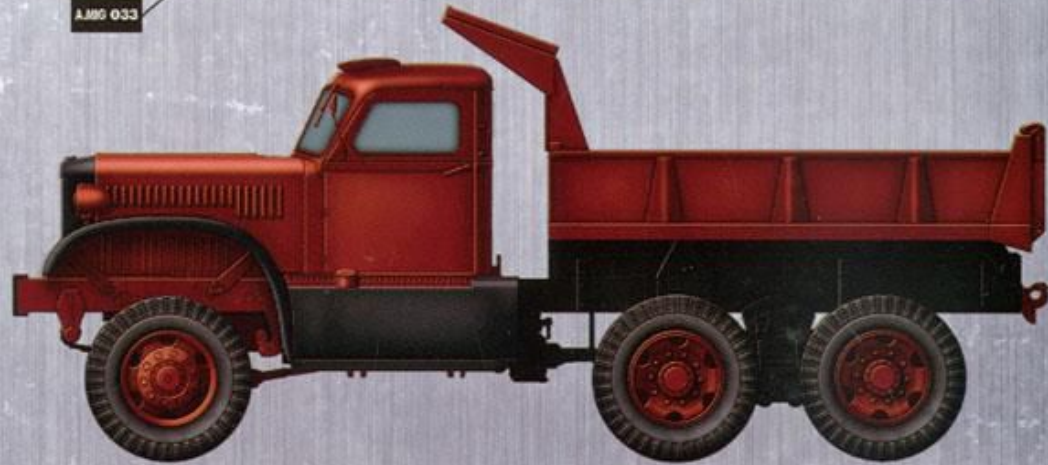
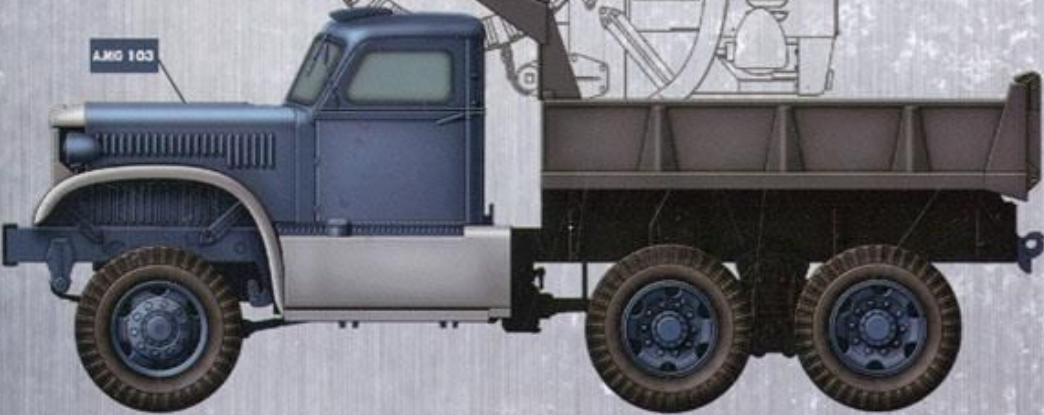

A.MIG 211

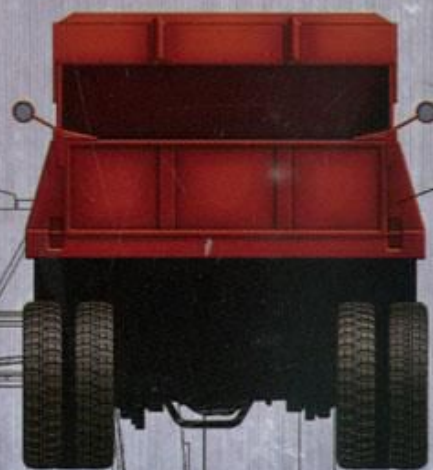

A.MIG 914