

# A PANTHER w/ Zimmerit Full Interior

## MID-LATE Production

Sd.Kfz. 267  
Sd.Kfz. 171 **2 in 1**

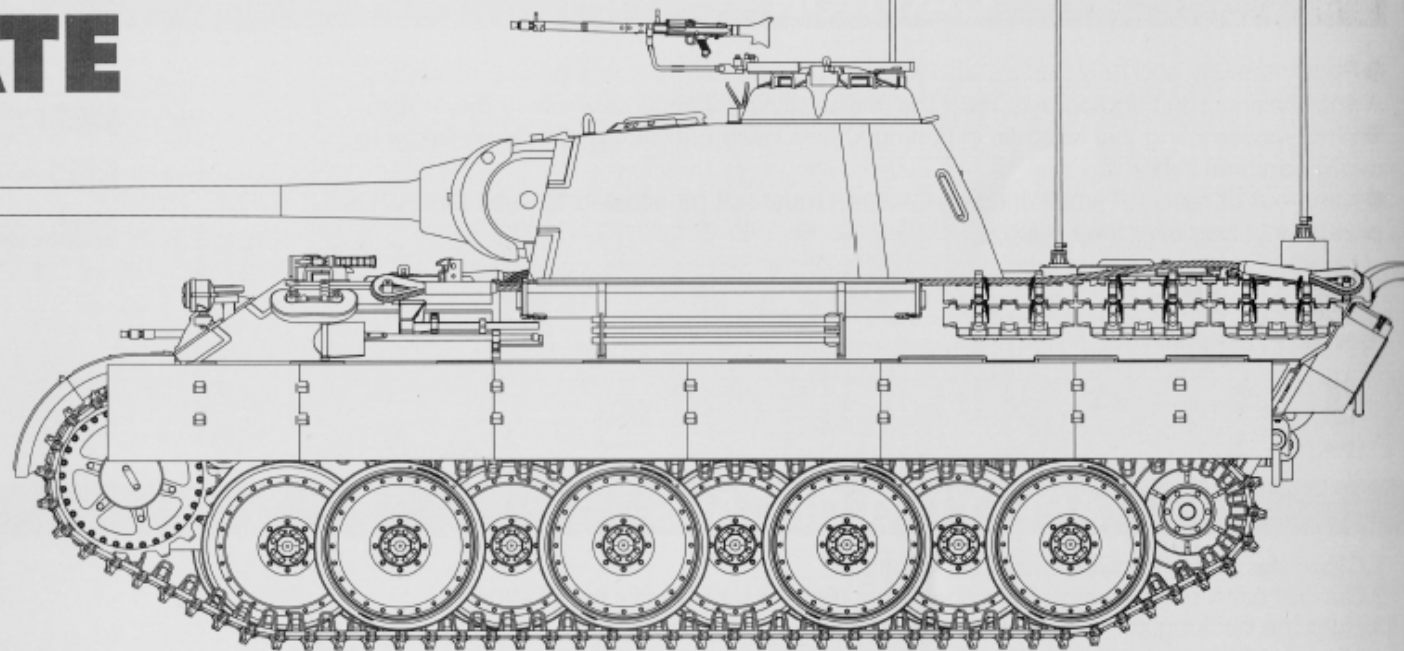

When the German Panzer IV met the Russian T-34 in June 1941, they were humiliated by being outclassed by the T-34, so a group of weapons specialists were sent to the Russian front to analyze the T-34's design. With these results, Daimler-Benz (DB) and Maschinenfabrik Augsburg (MAN) were both tasked with providing designs for a 30-ton medium tank by April 1942. The MAN design was accepted in May 1942, mainly because it was able to use an existing turret designed by Rheinmetall-Borsig, saving valuable time needed to design a new turret required with the DB design.

The Panther design adapted many of its successful design characteristics from the T-34. These were mainly the sloped armor, and the wide tracks (to make maneuvering in snow conditions of the Eastern front easier). In September 1942 the first prototype was tested and immediately pressed into service. Despite delays in production due to the lack of manufacturing equipment of the hull, the first rushed deliveries to the German Army were completed in December, but the tank was plagued by technical problems. Despite these early issues, the tank was very successful, and due to its high demand on the Eastern Front, the original production of 250 tanks per month at the MAN plant, was increased to 600 tanks per month in January in 1943, which resulted in production also being allocated to the Daimler-Benz, Maschinenfabrik Niedersachsen-Hannover (MNH), and the Henschel & Sohn plants to meet production quotas. Due to Allied bombing throughout the war, the required production amount was never met and only 6,000 in total were built.

The 700hp Maybach V-12 petrol engine with its seven-speed AK 7-200 synchromesh gearbox designed by ZF, was fitted with a governor in late 1943 to minimize engine failures by limiting the engine revolutions to 2500 rpm and reducing its power to 600 hp. This reduced the Panthers top speed from 55 km/h to 46 km/h. The Panther had a five-man crew: the driver, radio operator, gunner, loader, and commander.

The Panther was armed with a semi-automatic 75mm Rheinmetall-Borsig KwK 42 main gun, and could carry 79 rounds of three different types of ammunition: Armour-Piercing Capped Ballistic Capped, (APCBC), High-Explosive (HE) and Armour-Piercing Composite Rigid (APCR). The 75mm cannon on the Panther was one of the most powerful cannons of WWII, and had even greater success at piercing enemy armour than the Tiger I's 88mm cannon. The Panther was also equipped with two 7.92mm Maschinengewehr 34 (MG-34) for close quarter fighting; one was mounted coaxially with the main cannon and the second was mounted in the front sloping armour and operated by the radio operator. In later production upgrades, a mount was attached to the commander's cupola so a third MG-34 could be mounted for anti-aircraft purposes.

The frontal armor of the Panther consisted of 80mm homogeneous steel plate sloped back at 55 degrees from the vertical, interlocked & welded for strength. This made the Panther's frontal armor less penetrable to Allied and Soviet tanks. The front of the turret was covered by a 100mm cast mantlet in the shape of a semi-circle, with a curved shape meant to deflect incoming shells. To keep weight down, sacrifice was made to its side armor, which was on average 40mm to 50mm thick, leaving the Panther vulnerable to attacks from the sides by Allied and Soviet tank and anti-tank guns.

# READ BEFORE ASSEMBLY

## CAUTION

- Read carefully and fully understand the instructions before commencing assembly. A supervising adult should also read the instructions if a child assembles the model.
- When assembling this kit, tools including knives used. Extra care should be taken to avoid personal injury.
- Keep out of reach of small children. Children must not be allowed to suck any part, or pull vinyl bag over their heads.



Optional



Remove



Drill

## PAINTS REQUIRED

Color info and profiles by Mig Jimenez

A.MIG 033 Rubber & Tires	A.MIG 035 Dark Tracks	A.MIG 036 Old Wood	A.MIG 038 Old Wood
A.MIG 040 Medium Rust	A.MIG 045 Gun Metal	A.MIG 063 Crystal Red	A.MIG 096 Crystal Periscope Green
A.MIG 010 Dunkelgelb Mid war	A.MIG 015 Schokobraun	A.MIG 002 Olivgrun Opt.2	

## APPLYING DECALS

1. Clean the model surface with a wet cloth.
2. Cut out each decal design from sheet, and dip it in tepid water for 15~20 sec.
3. Hold the backing sheet edge and slide decal onto the model.
4. Move decal into position by wetting decal with finger.
5. Press decal gently down with a soft cloth until excess water and air bubbles are gone.

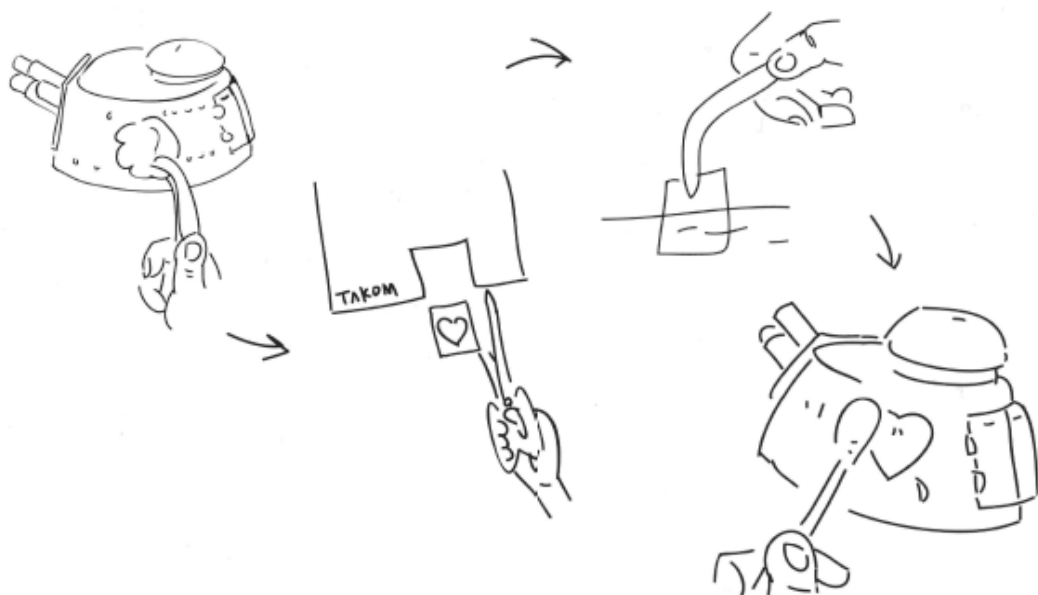

## REMOVING PE

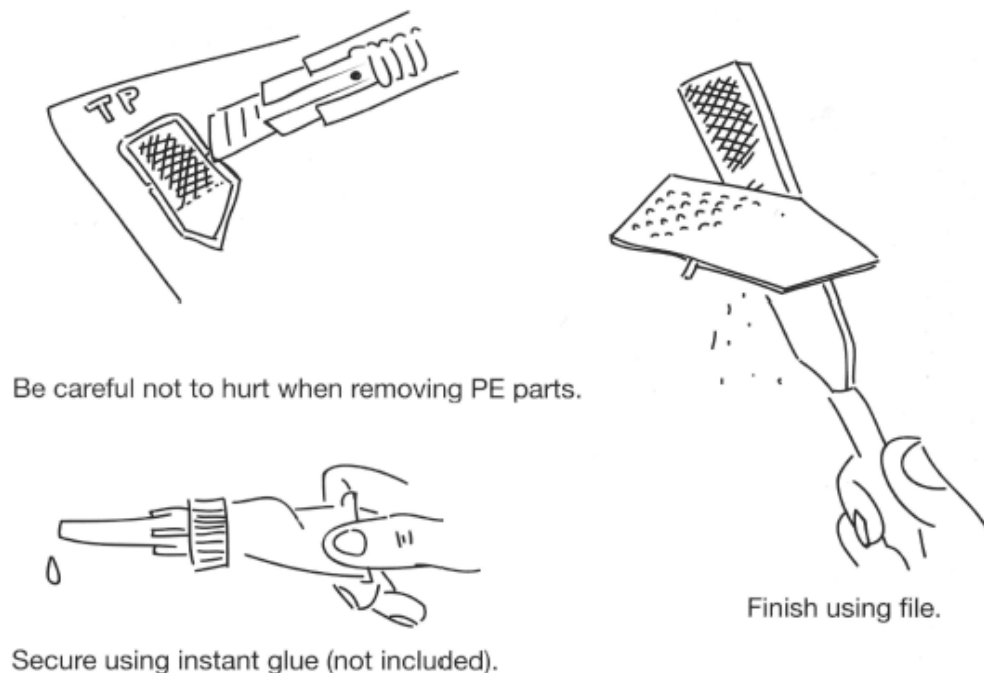

# PARTS

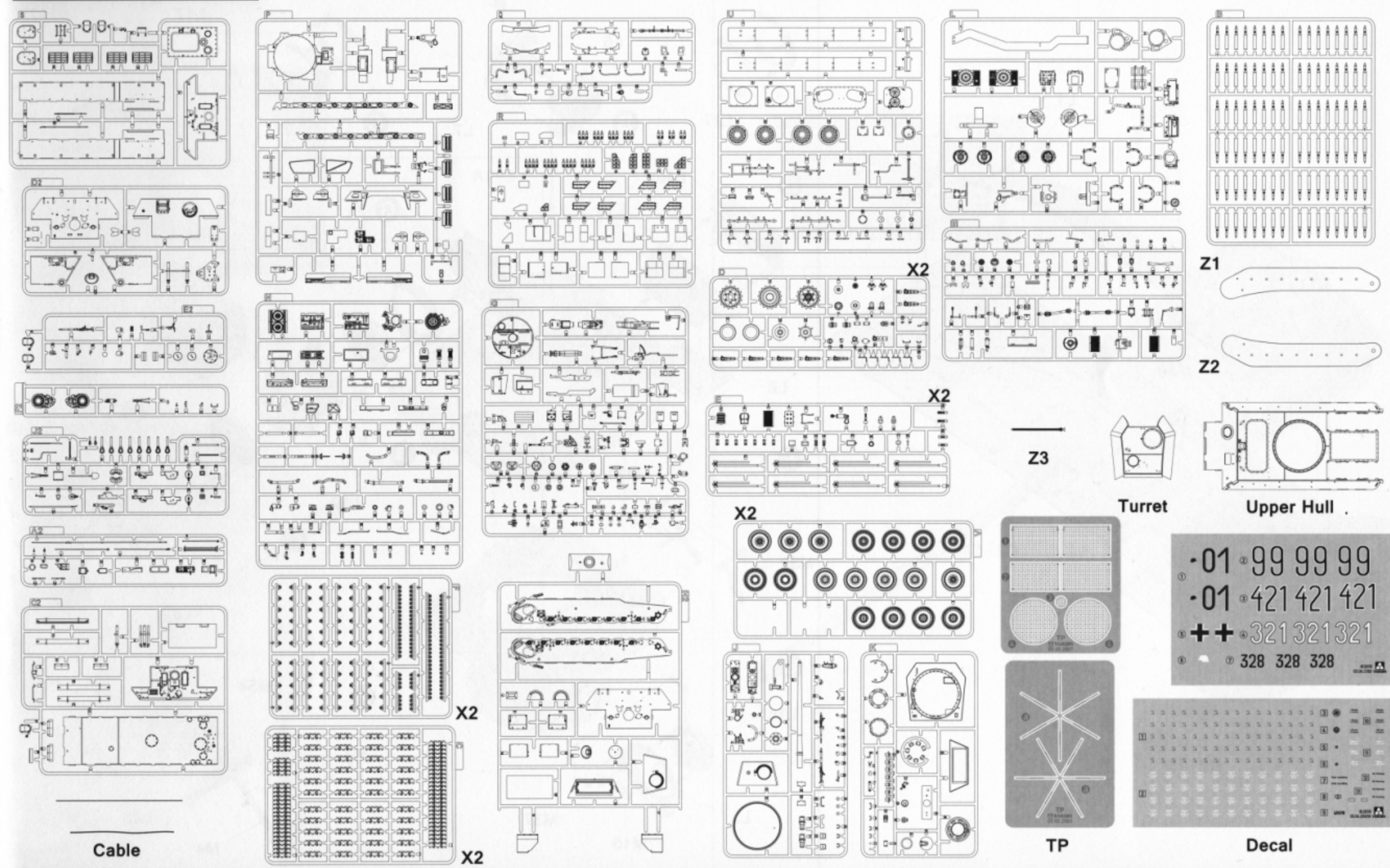

01 99 99 99  
 01 421 421 421  
 ++ 321 321 321  
 328 328 328



1

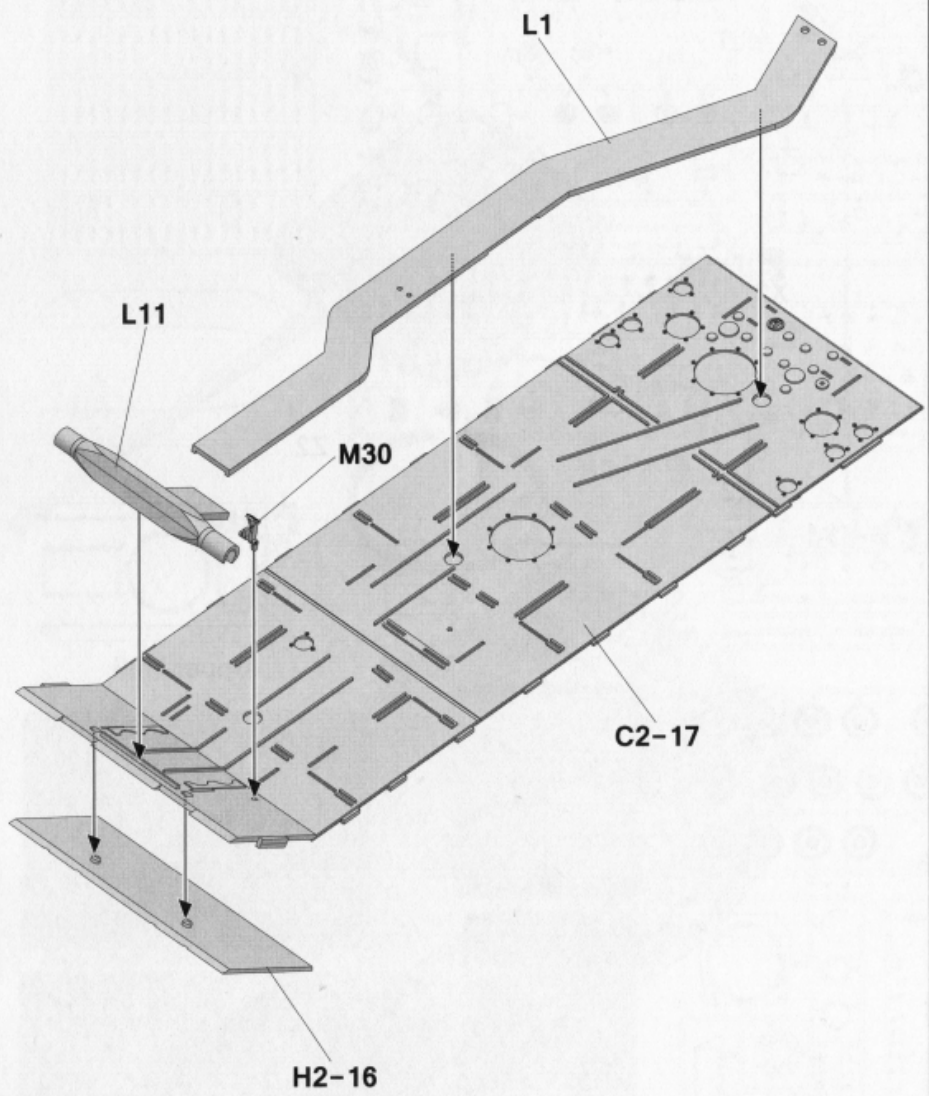

2

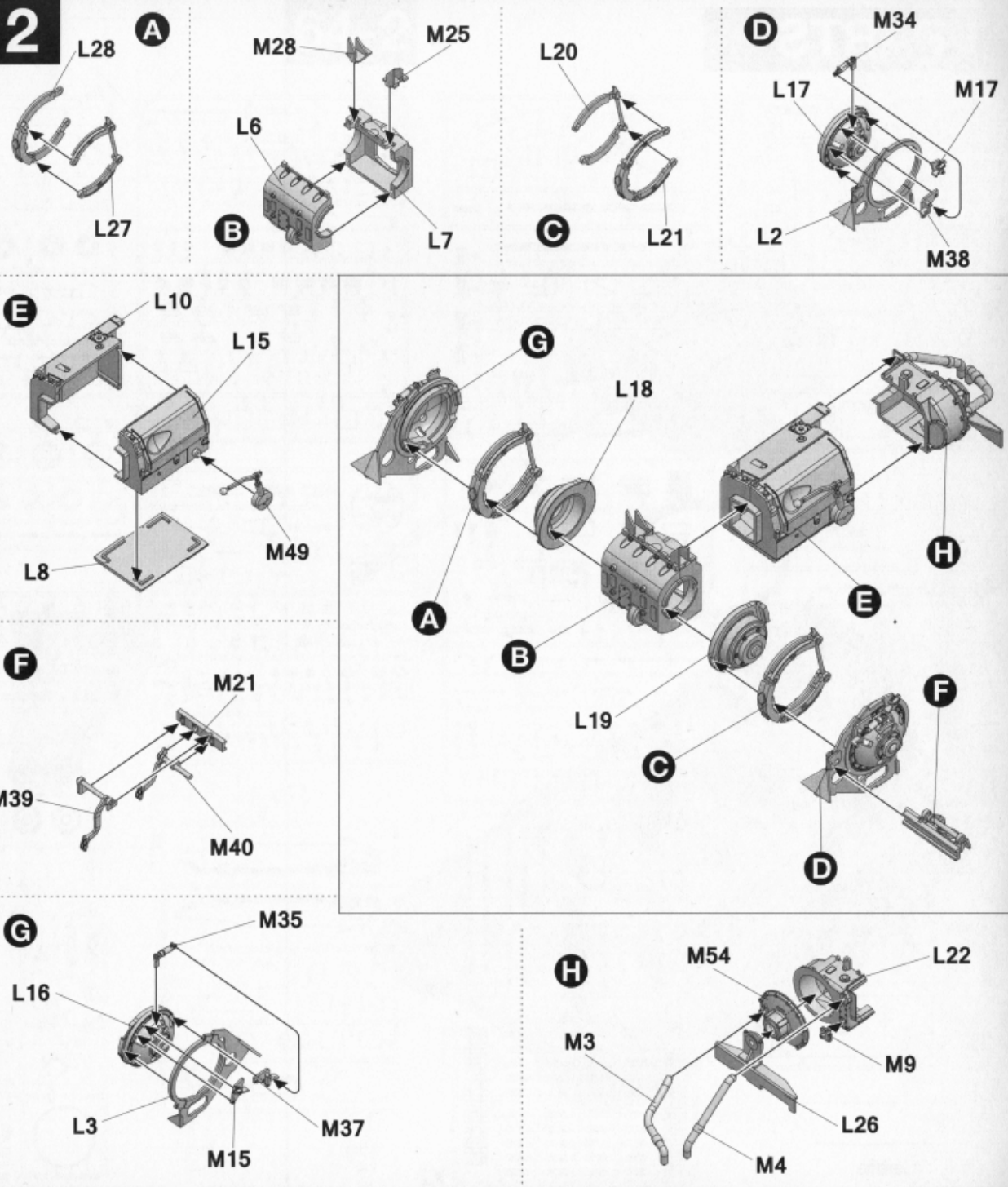

3



3

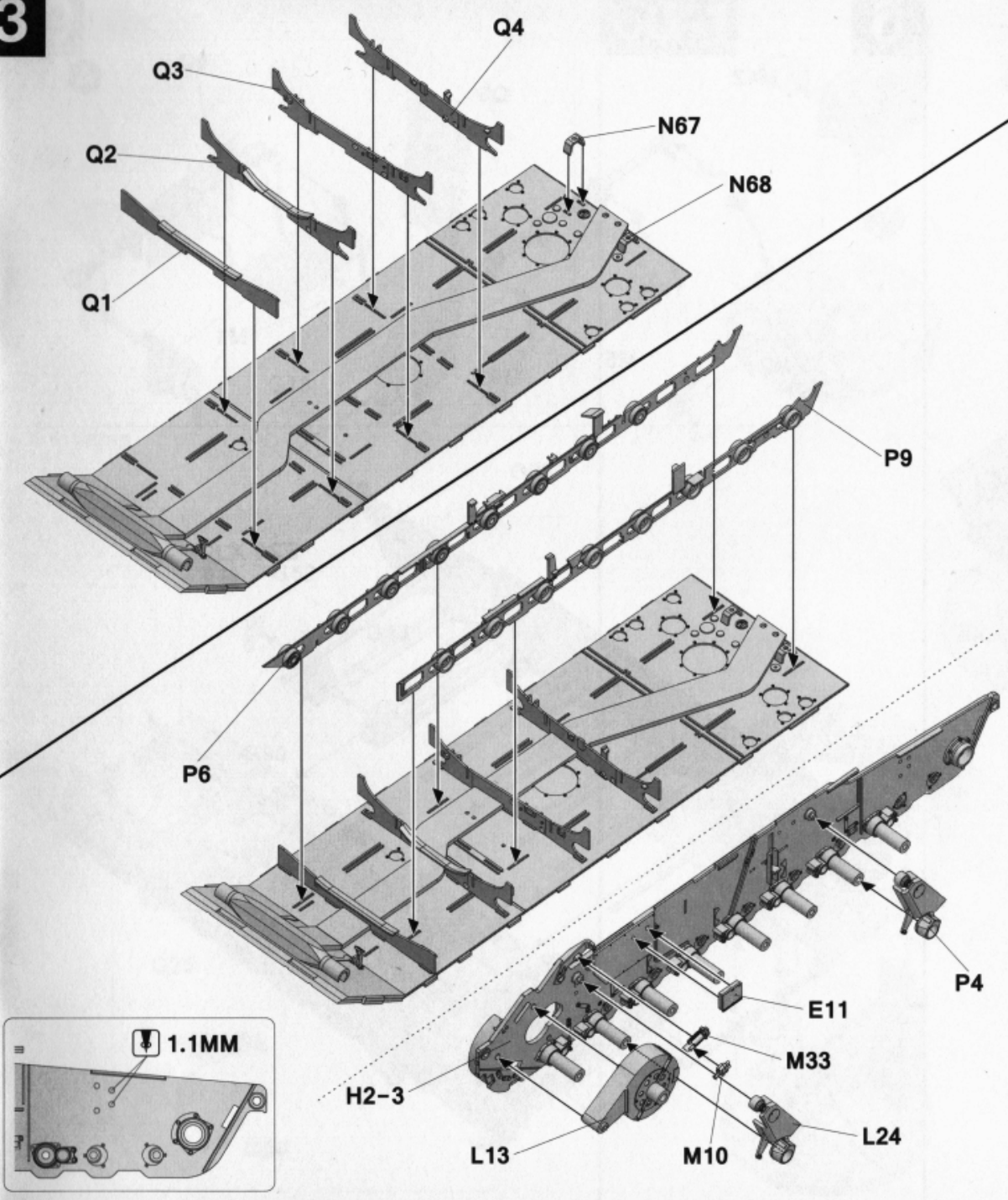

4

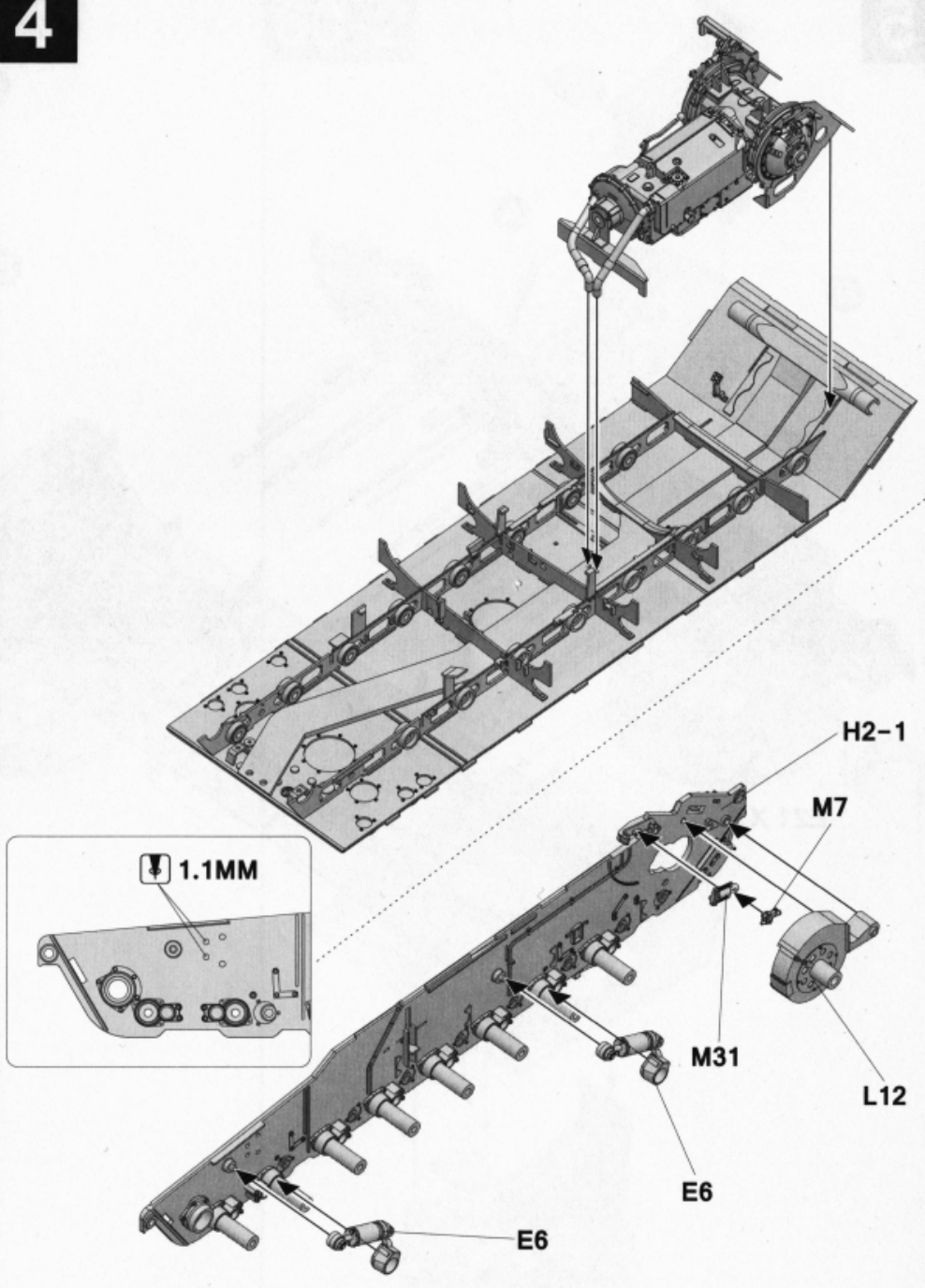

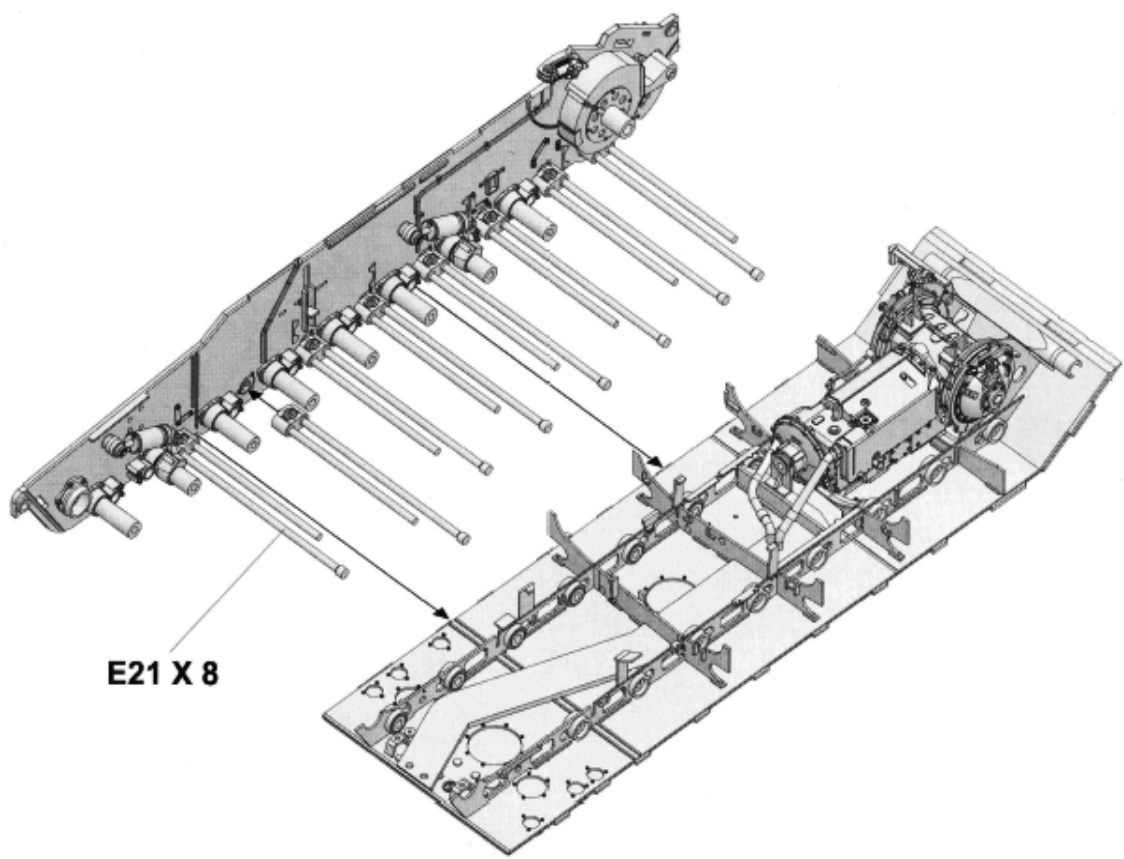

E21 X 8

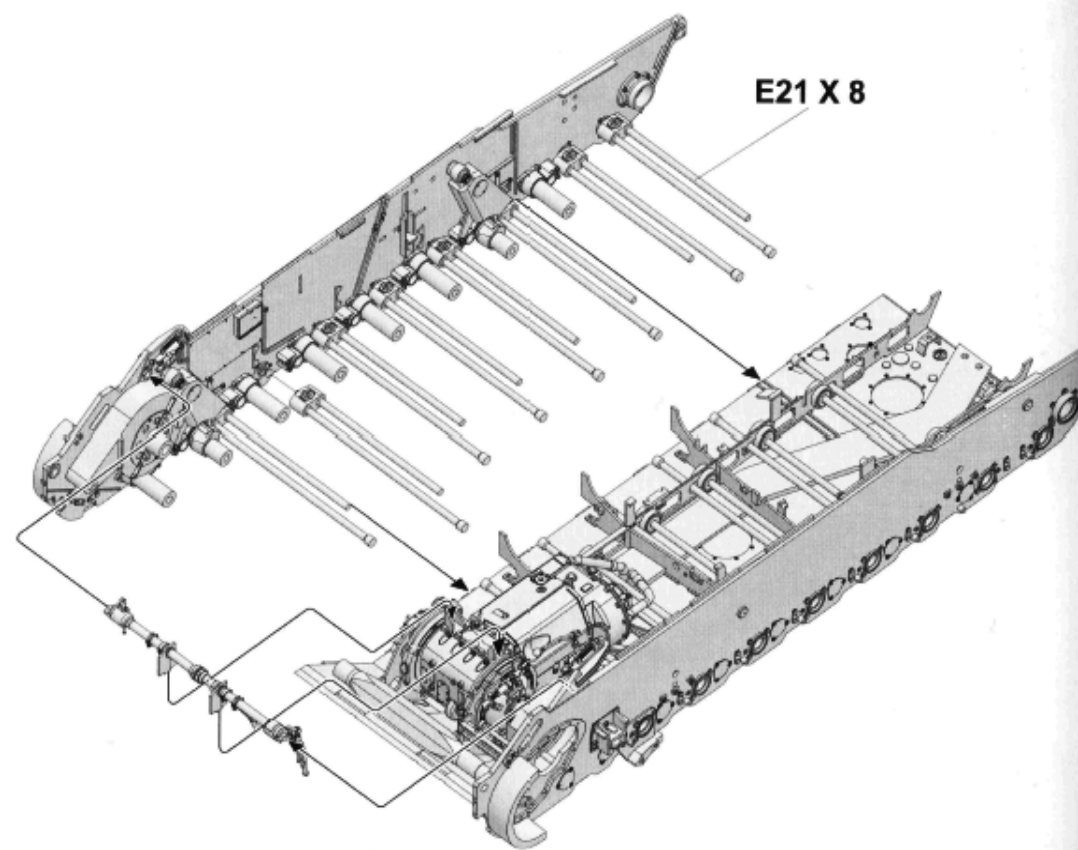
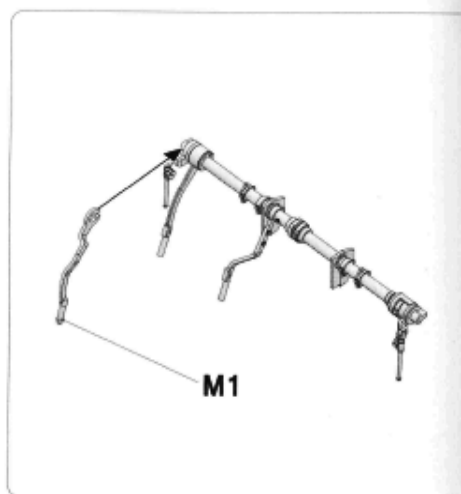
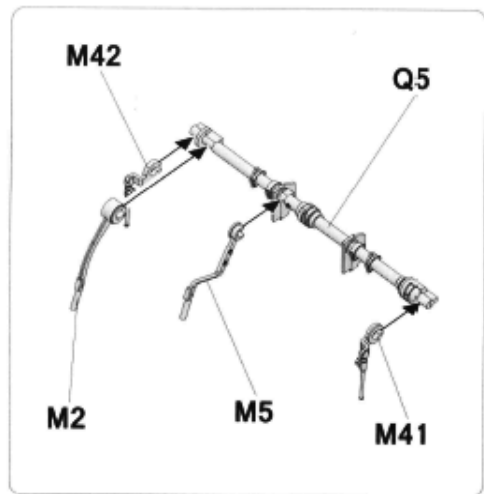

E21 X 8



7

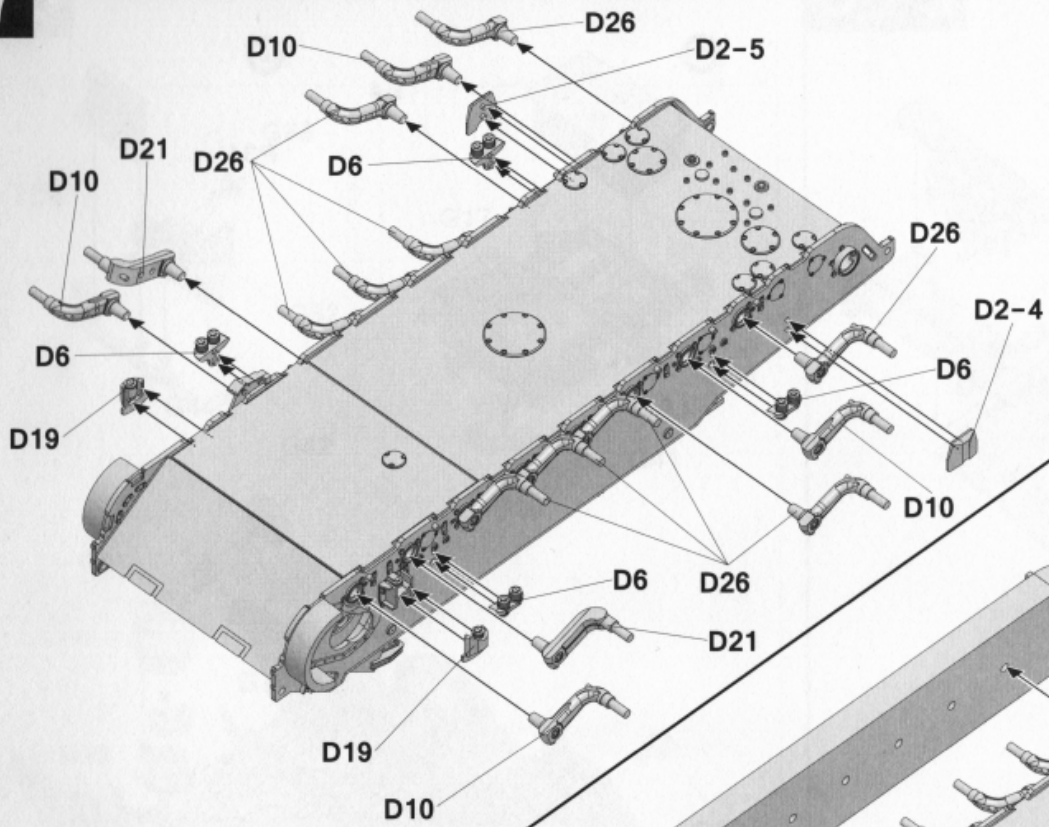

9

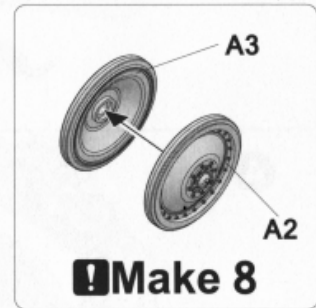
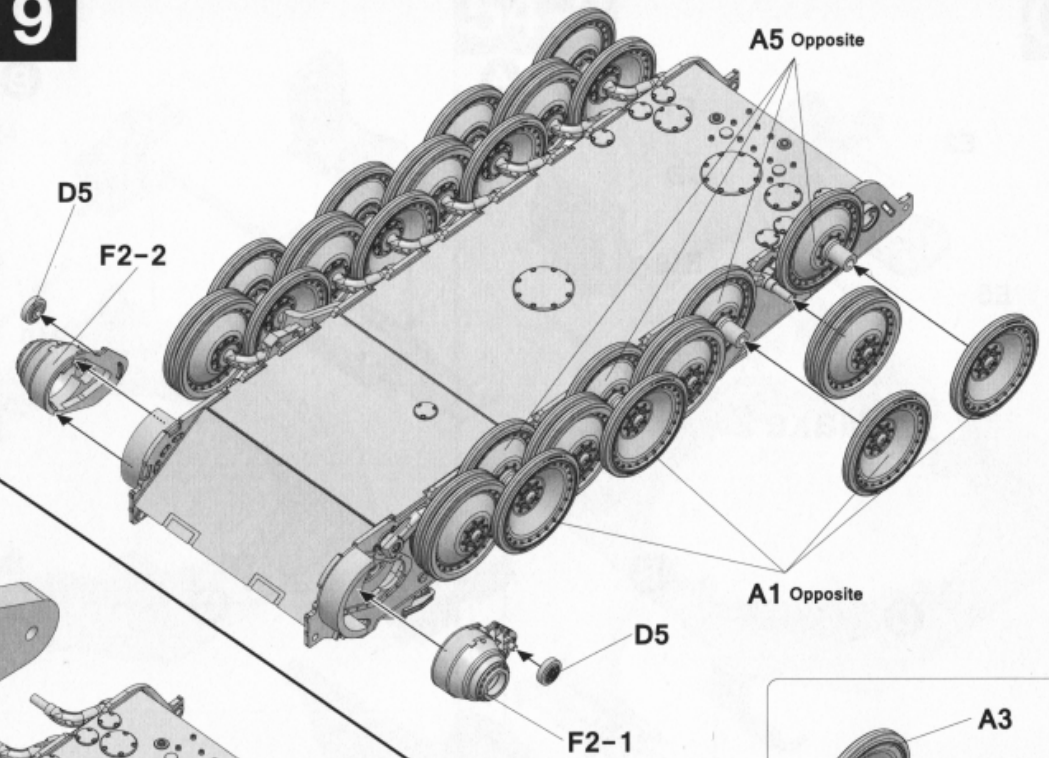

8

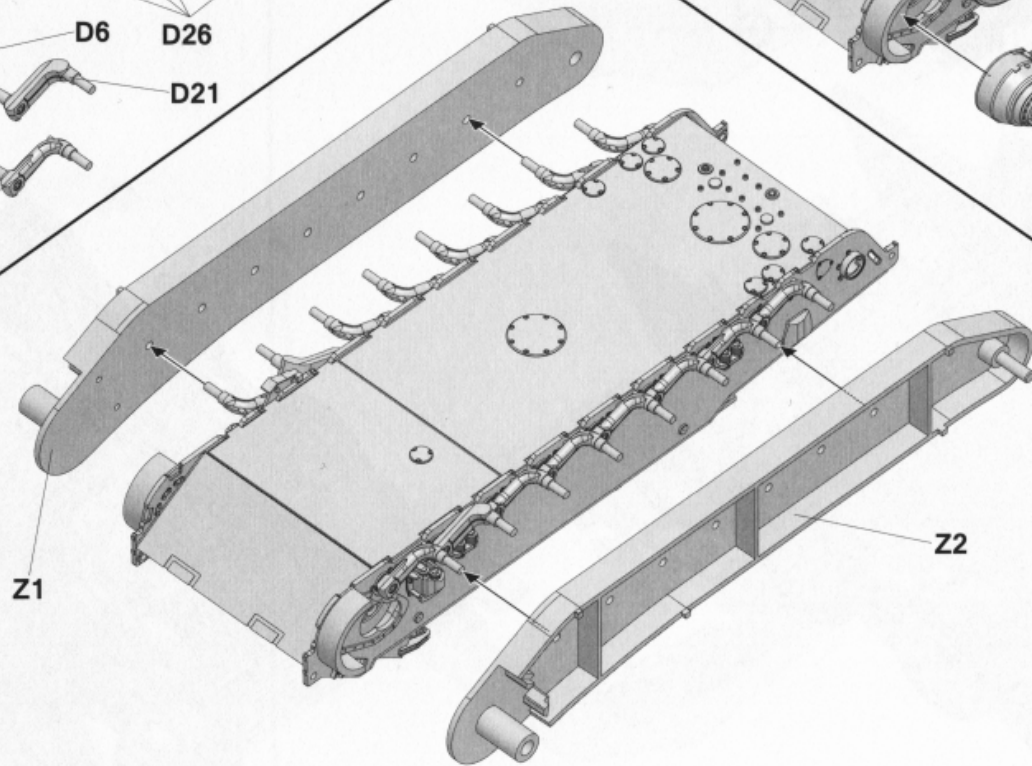

6



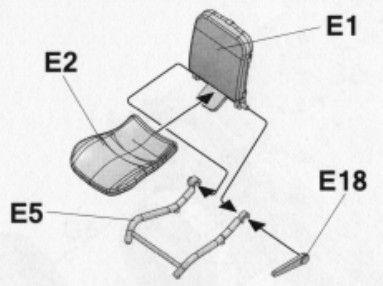

**Make 2**

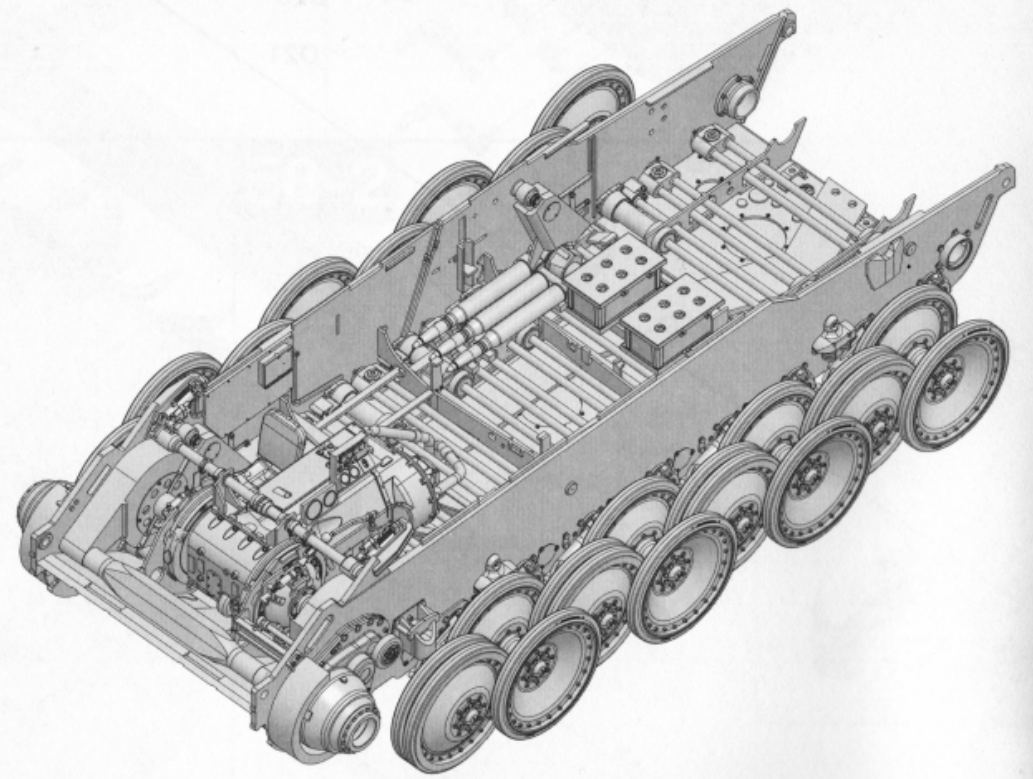
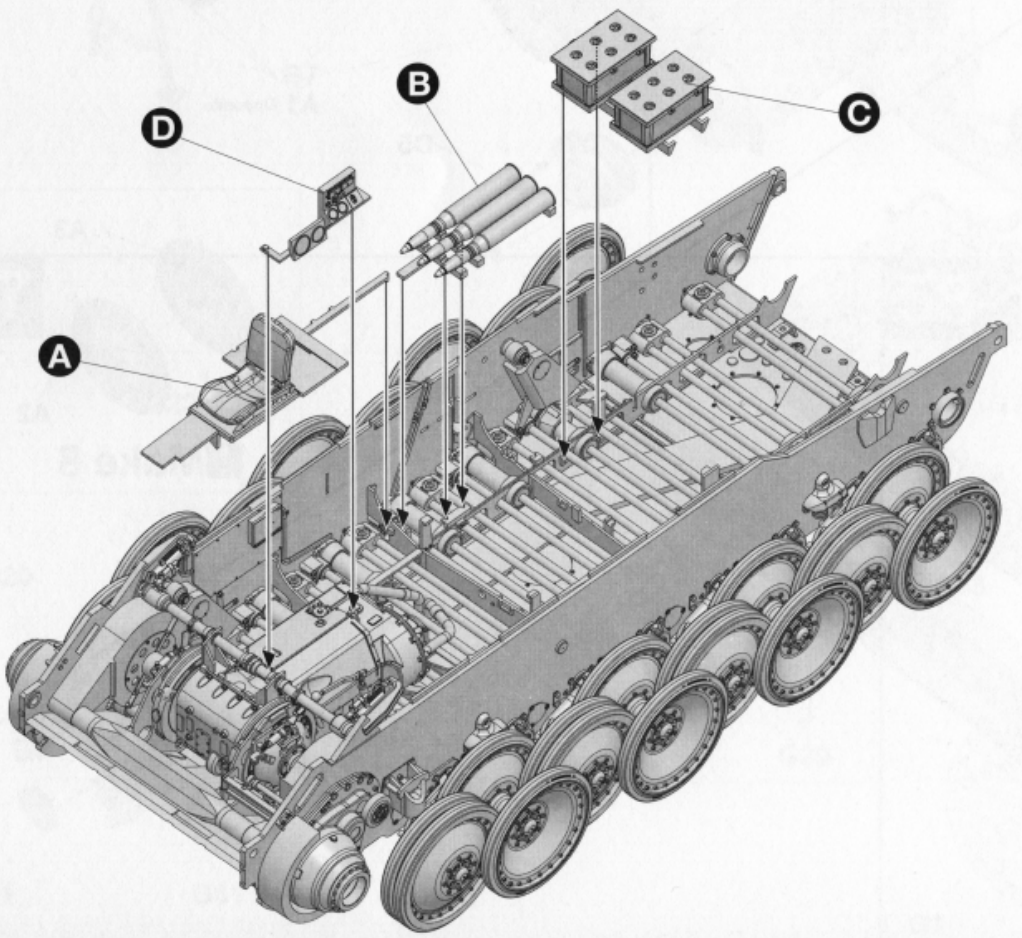
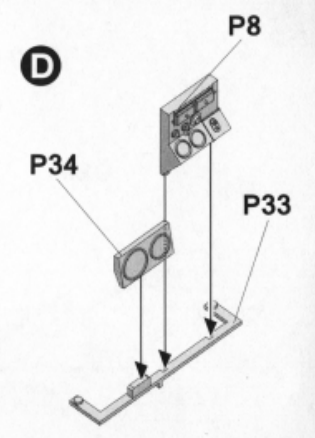
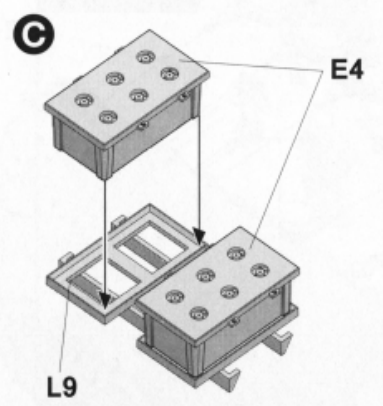
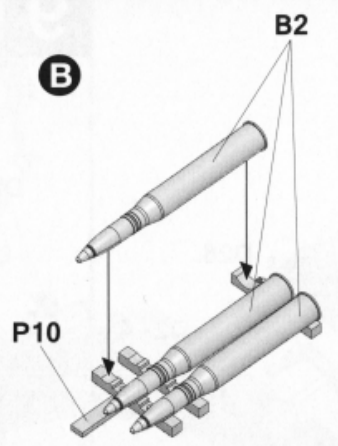
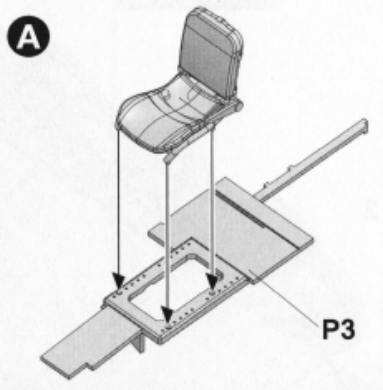



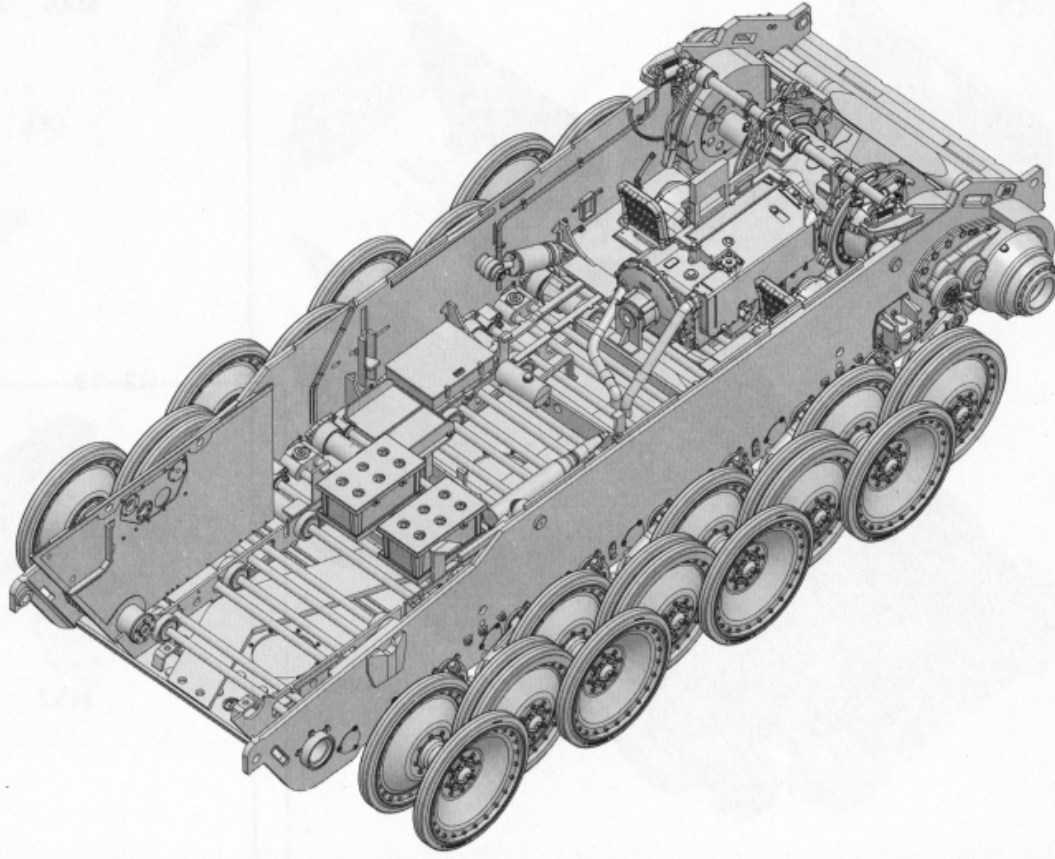
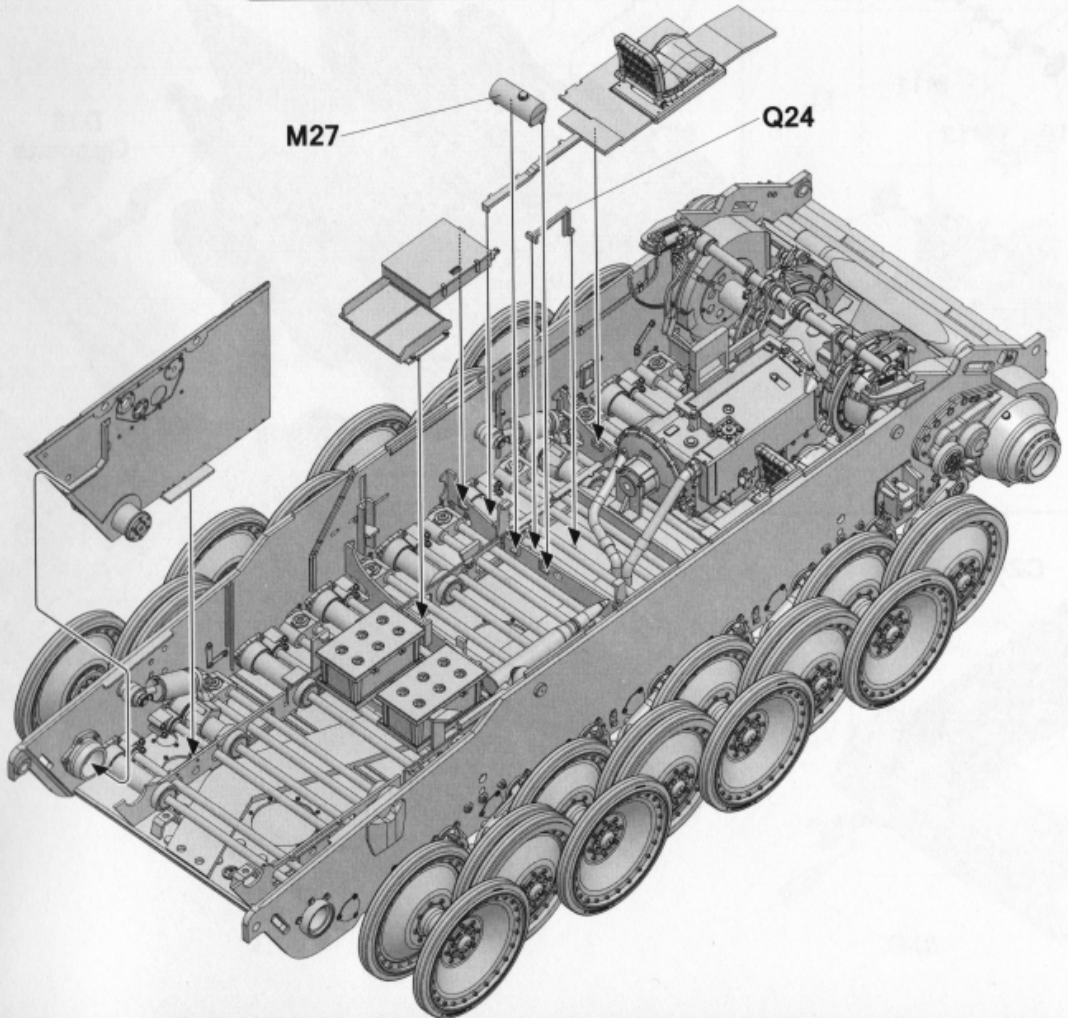
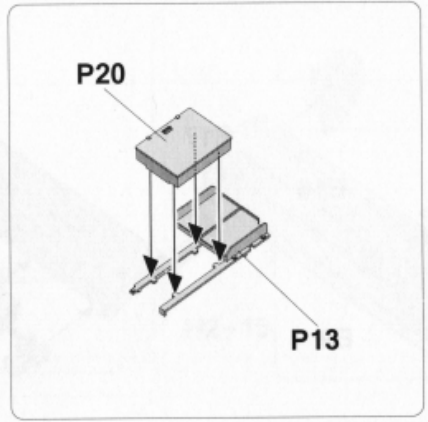
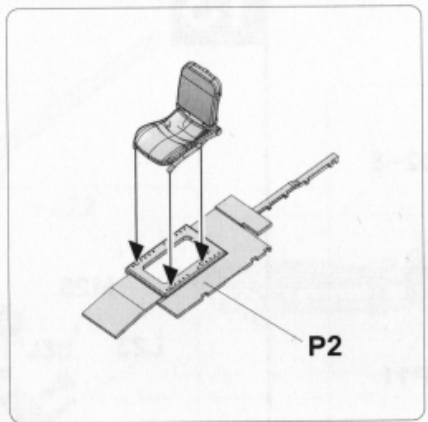
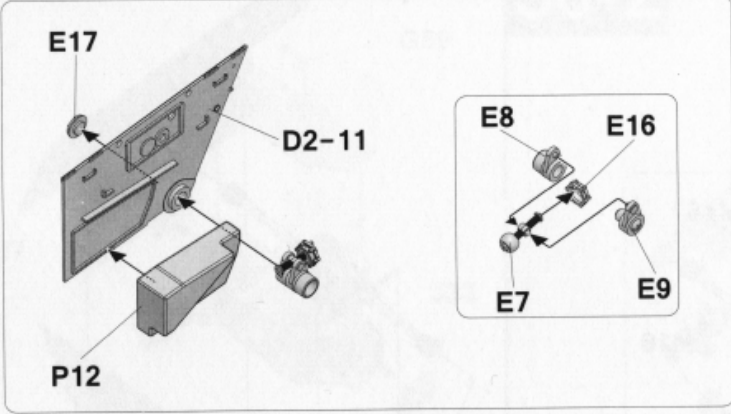



12

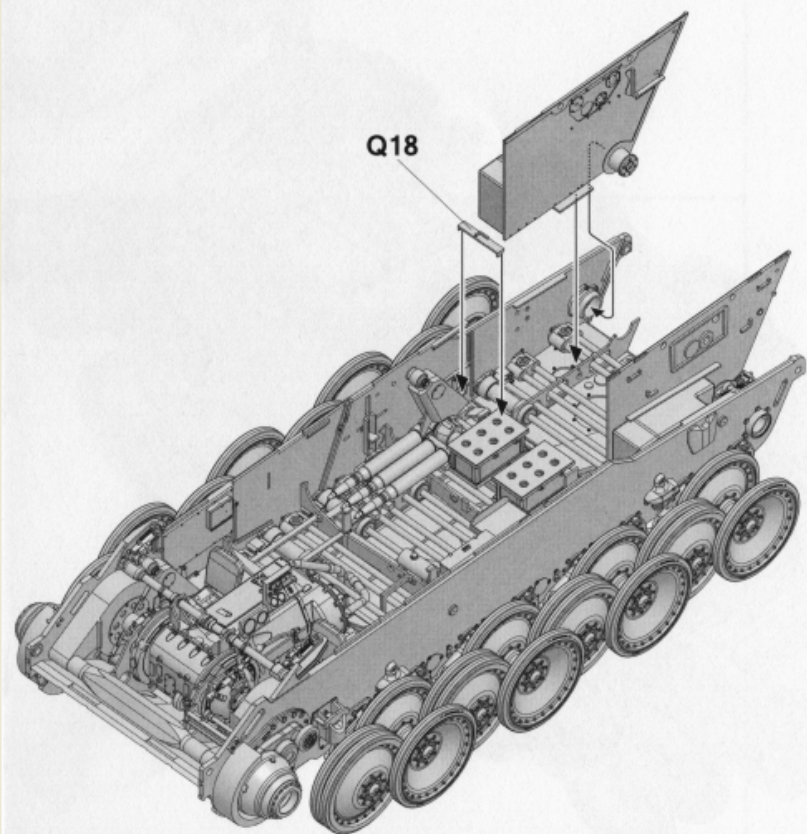
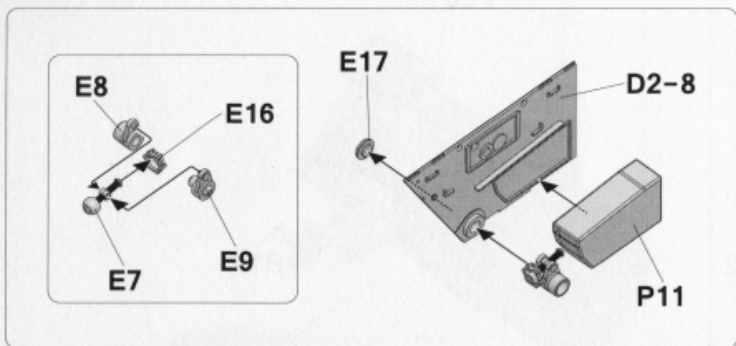

13

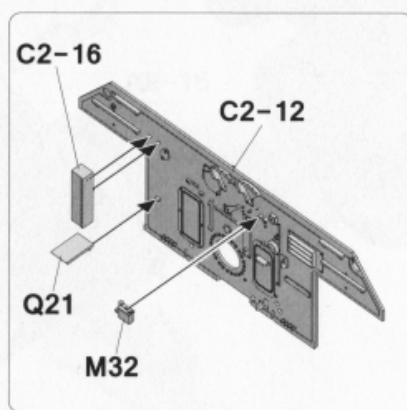
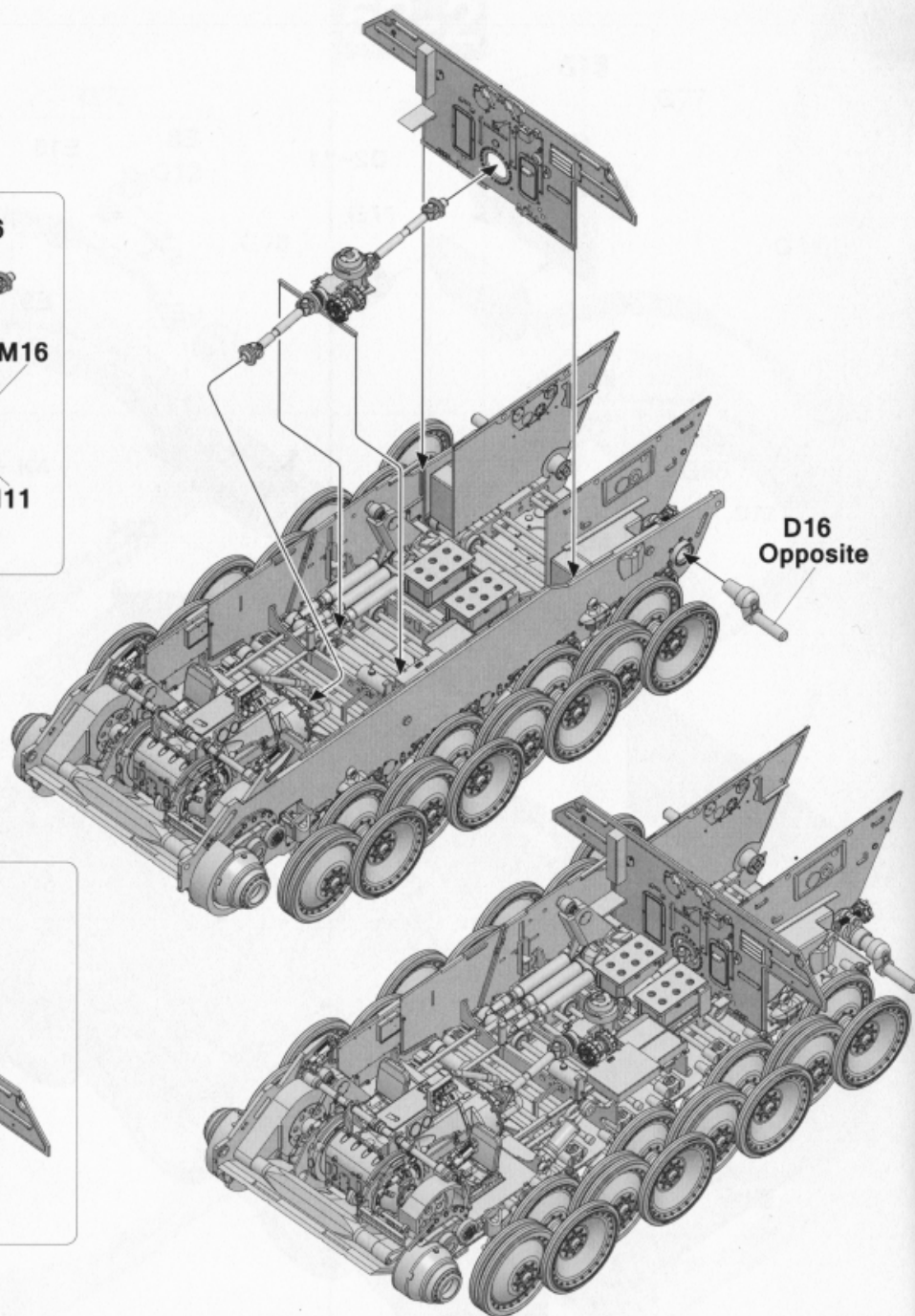
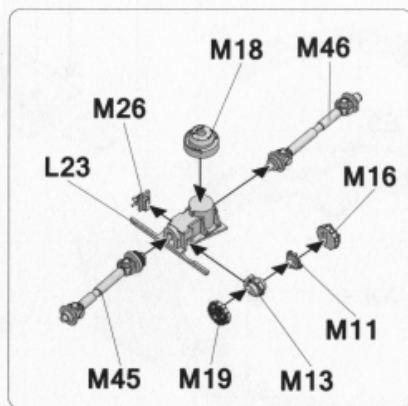



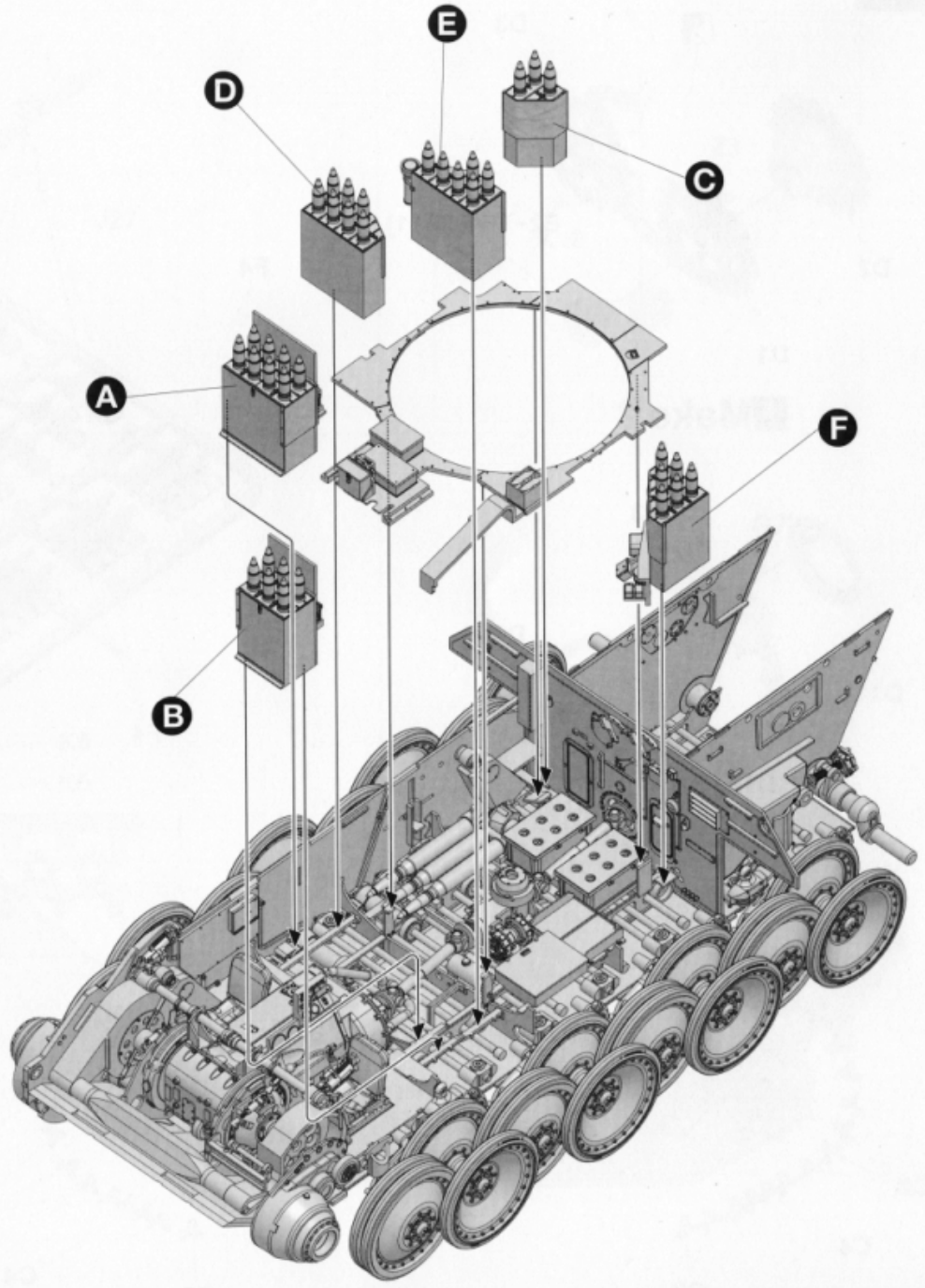
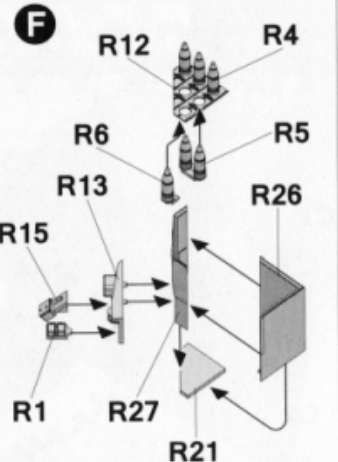
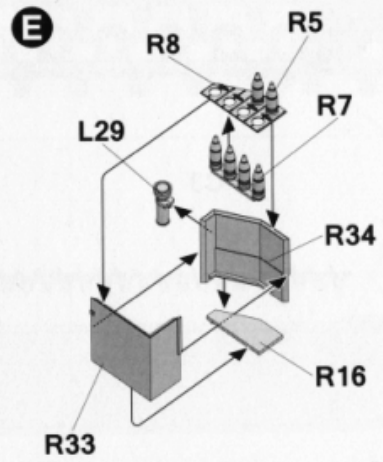
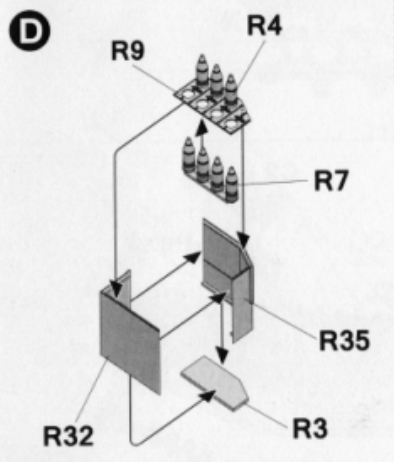
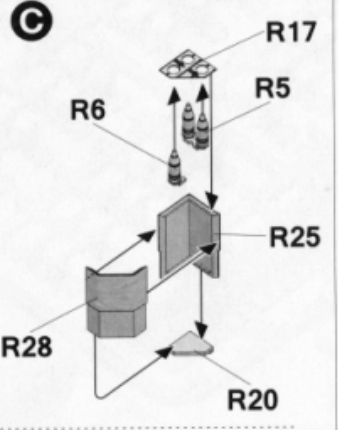
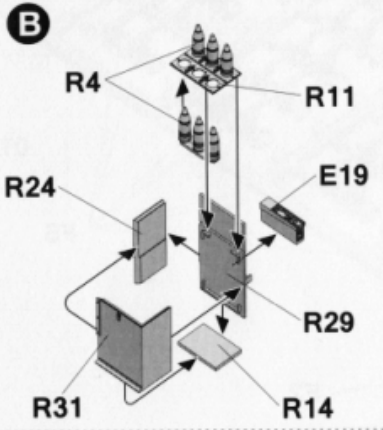
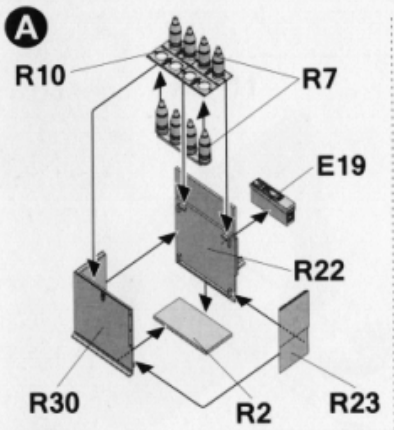
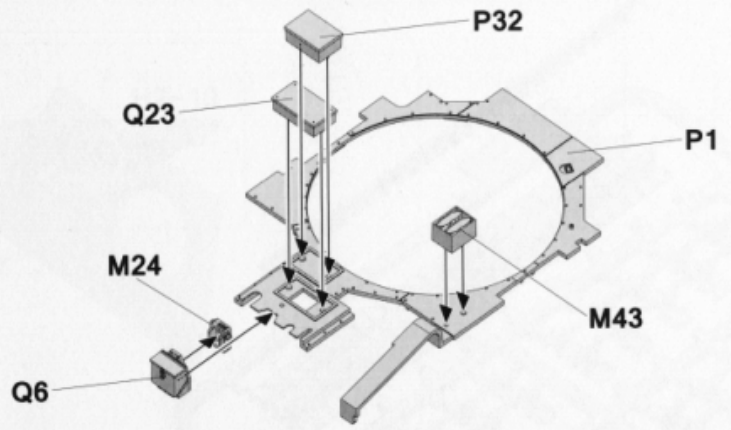

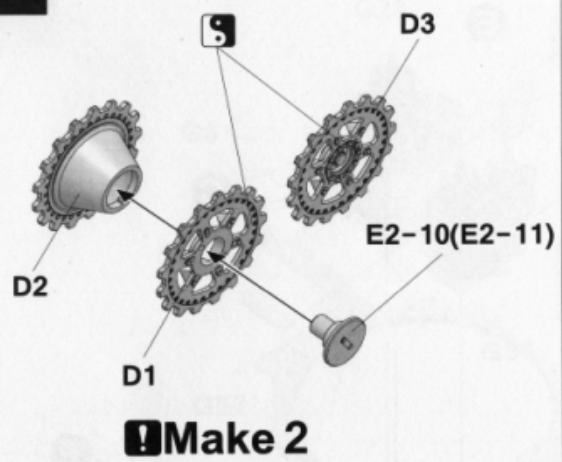

**Make 2**

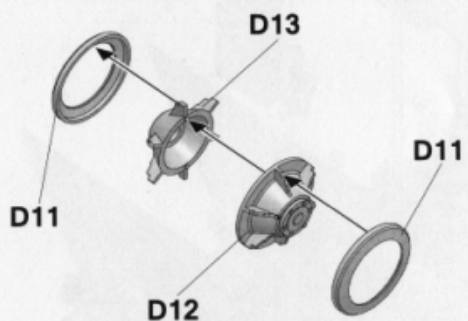

**Make 2**

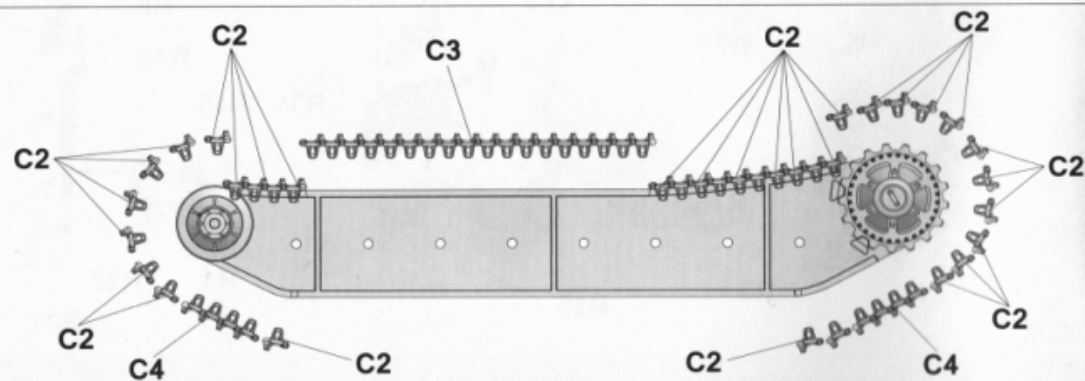
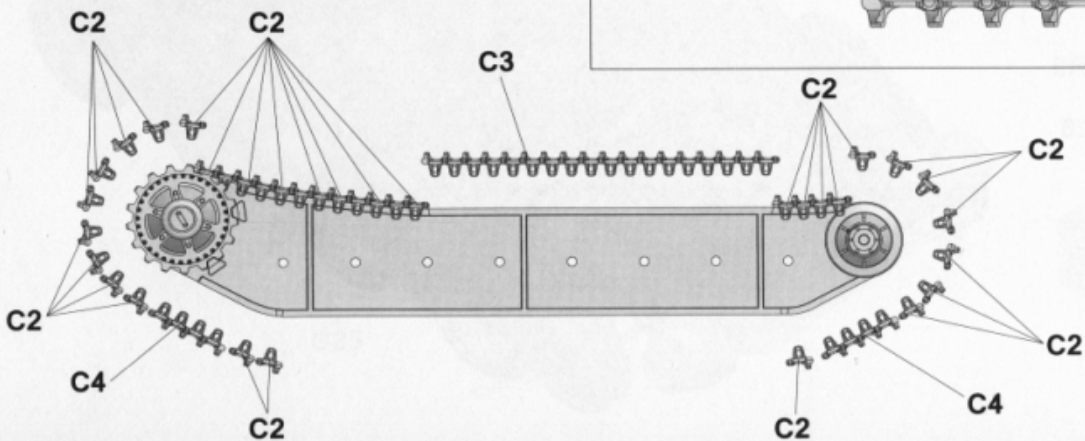
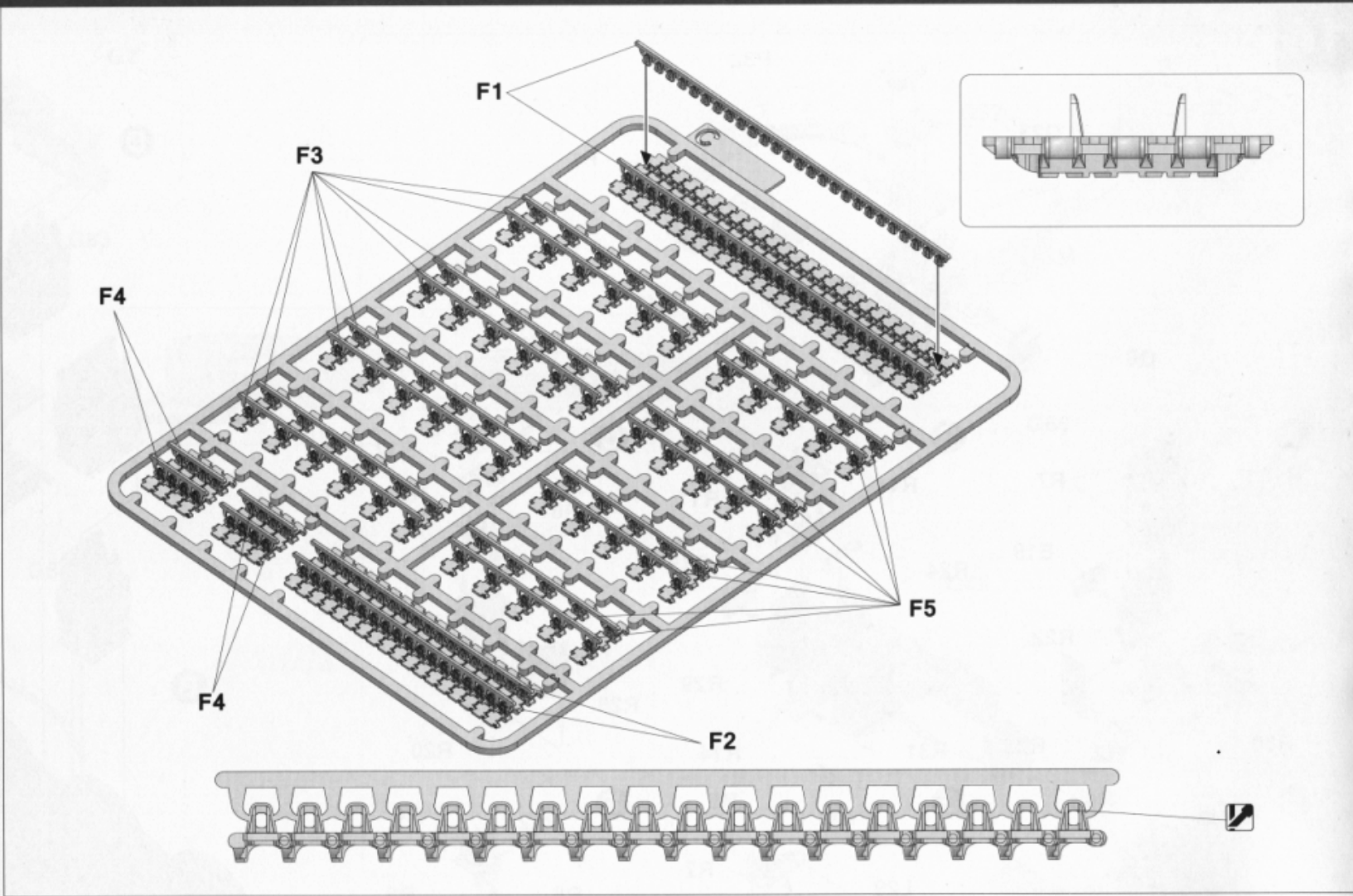



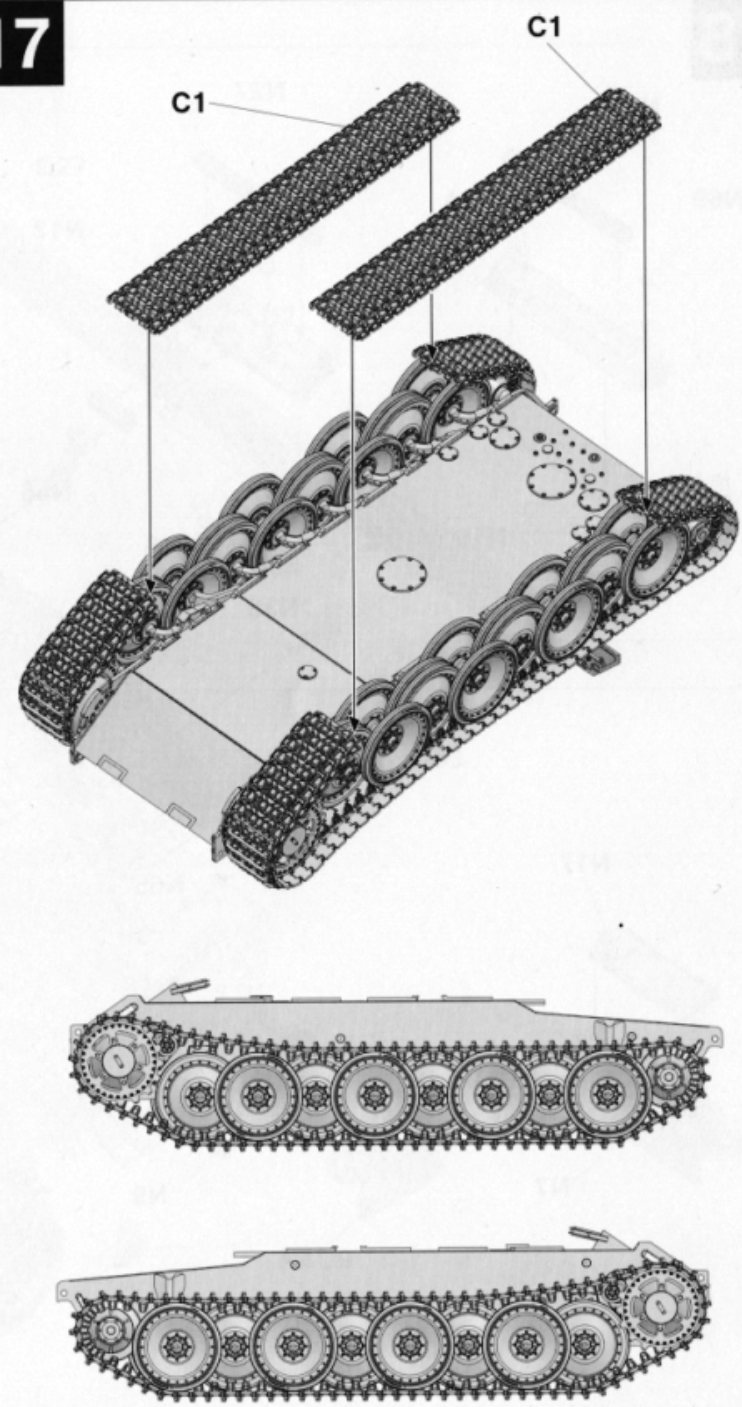
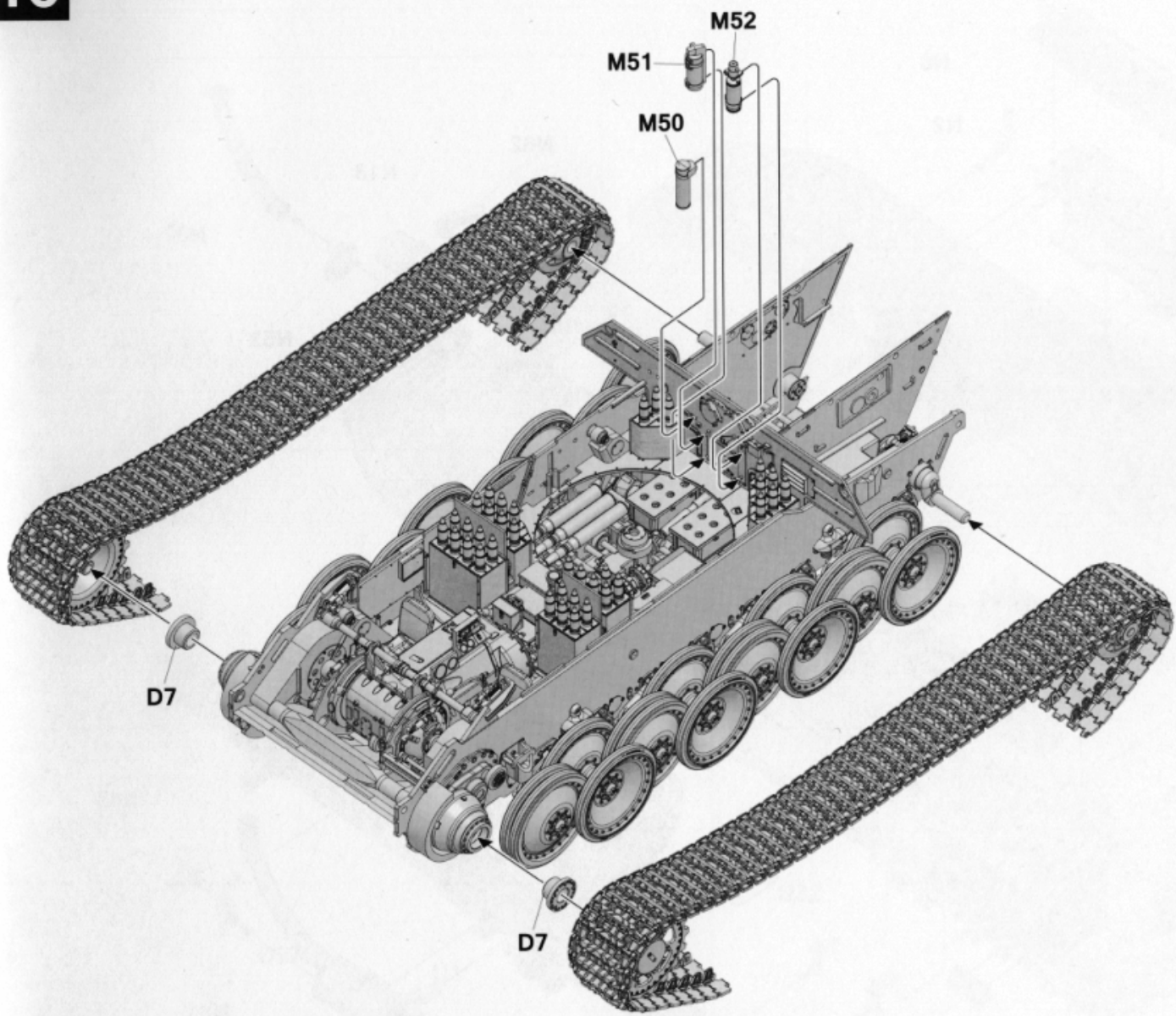



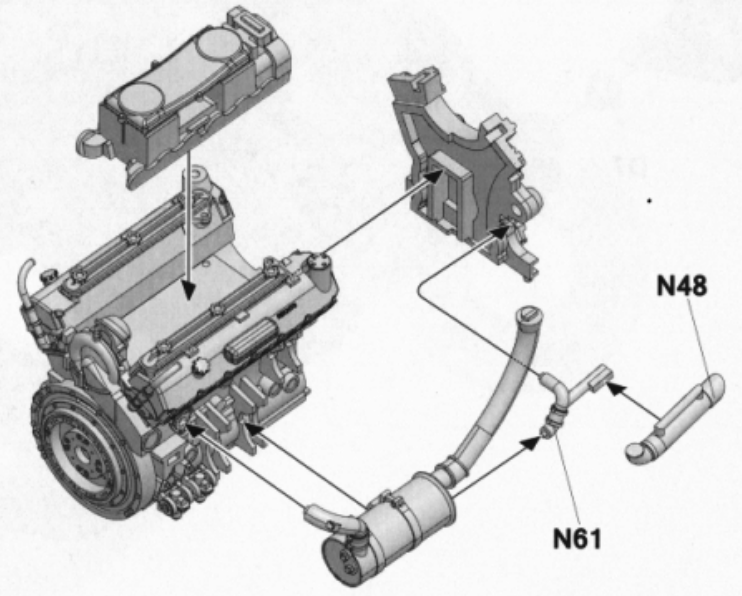
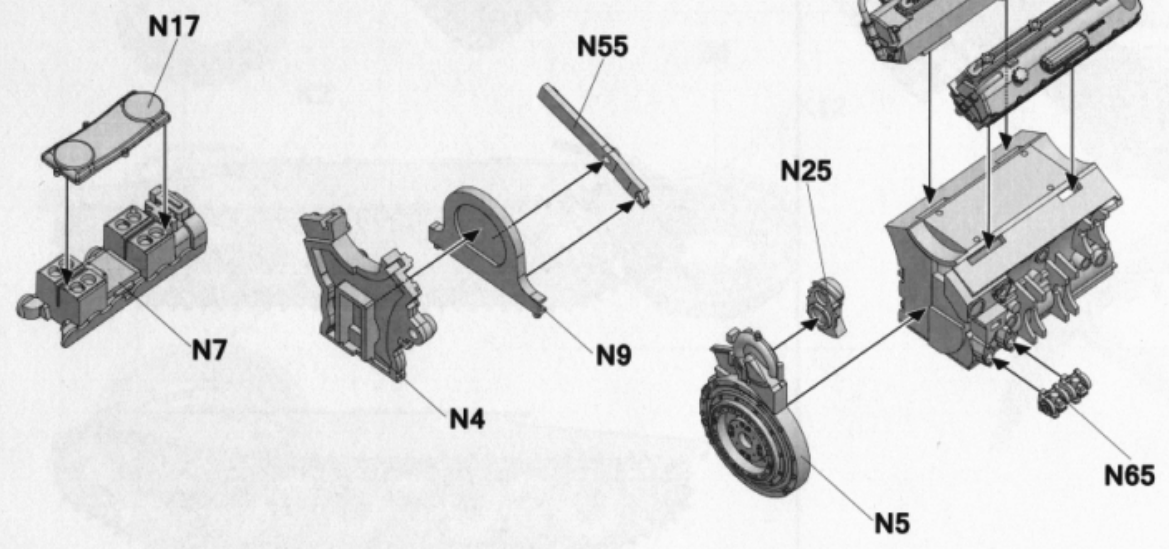
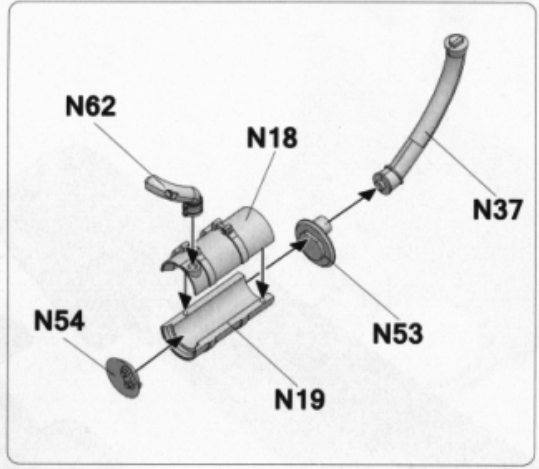
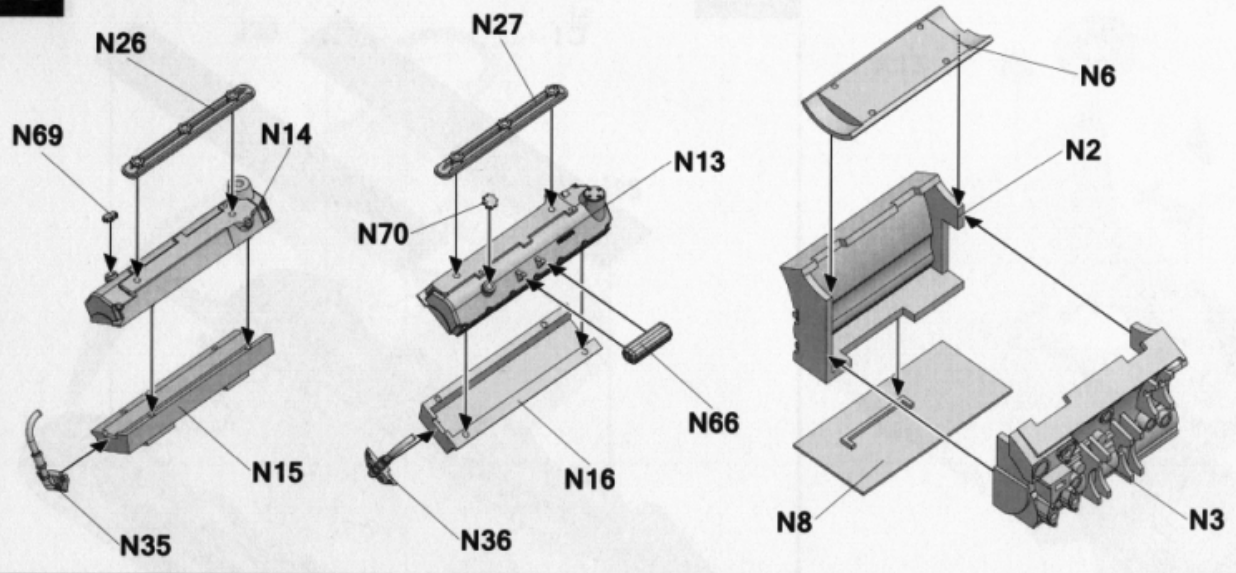

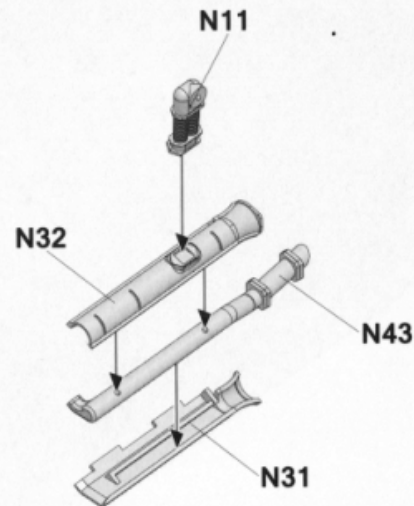
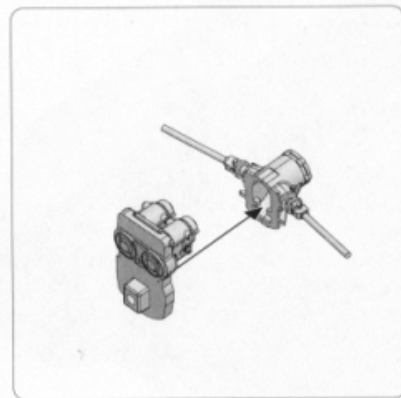
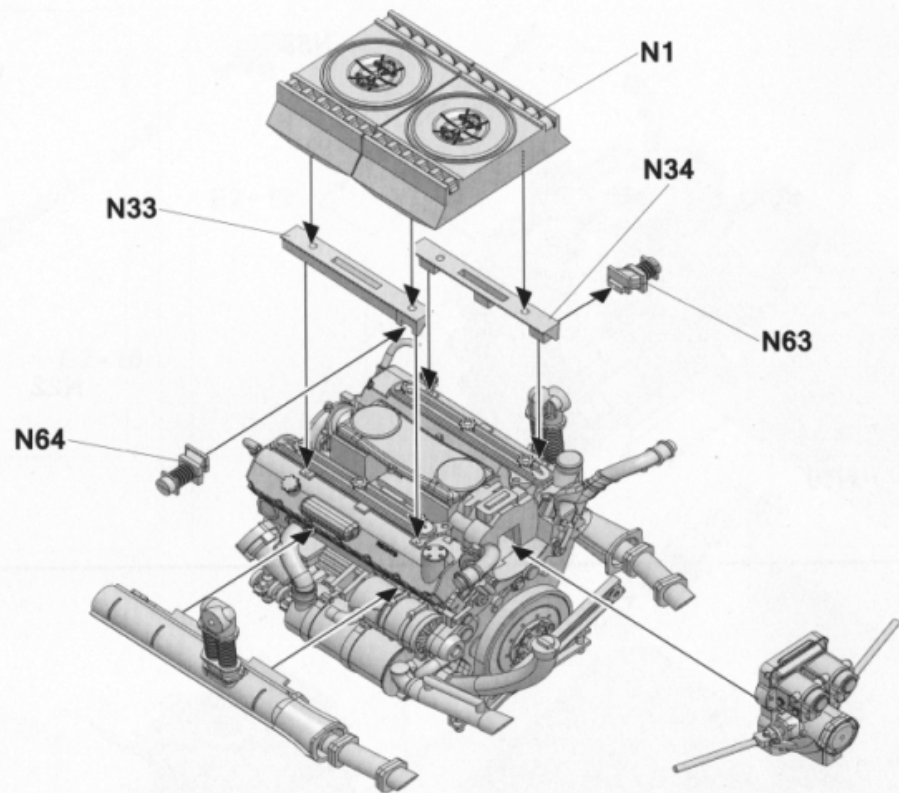
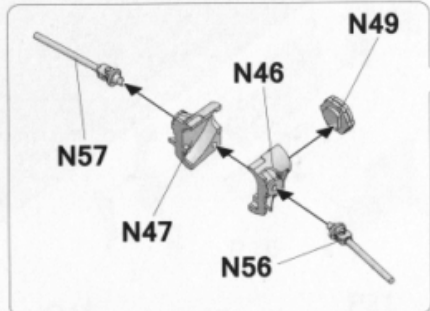
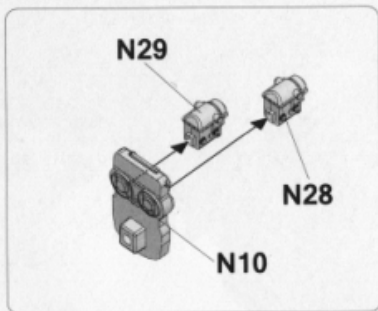
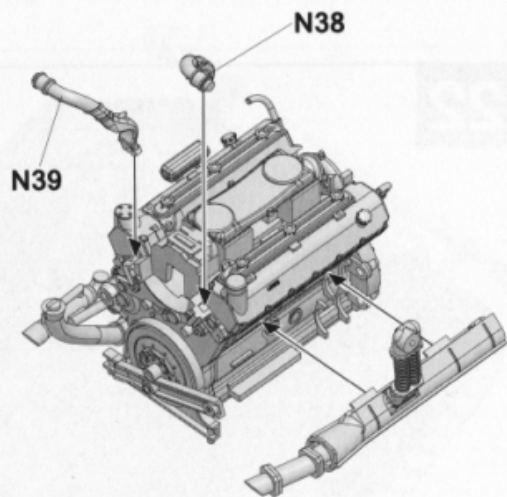
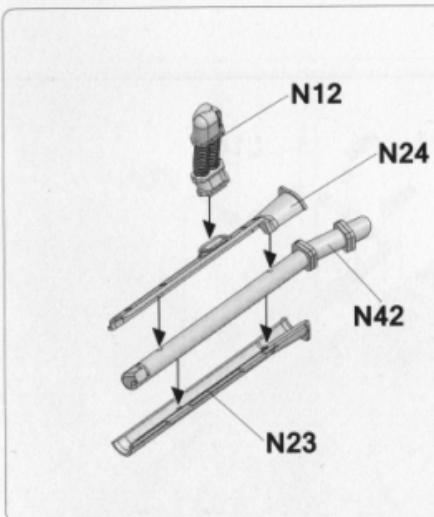
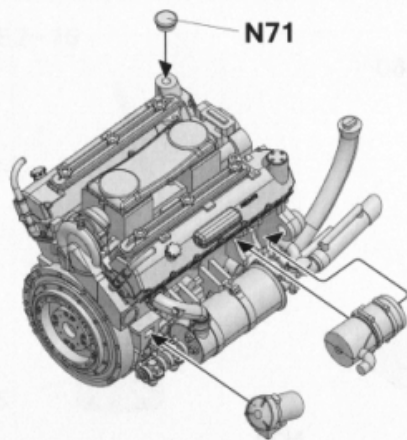
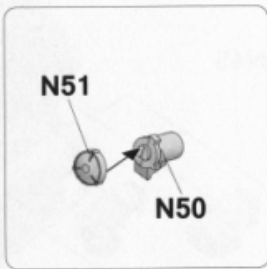
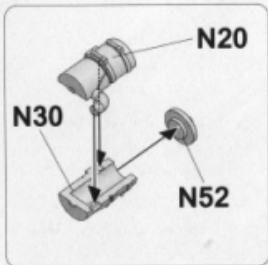



20

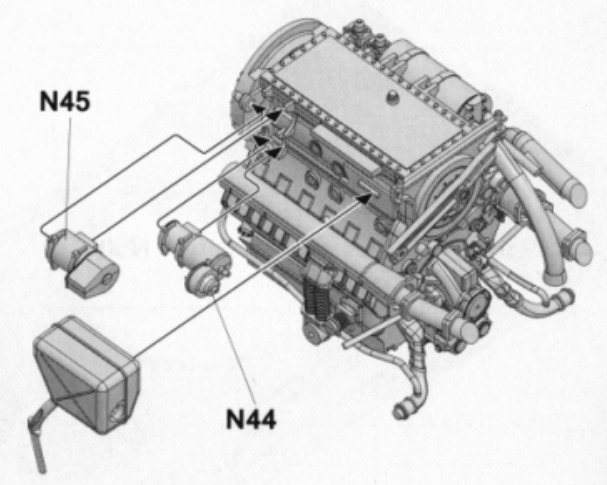
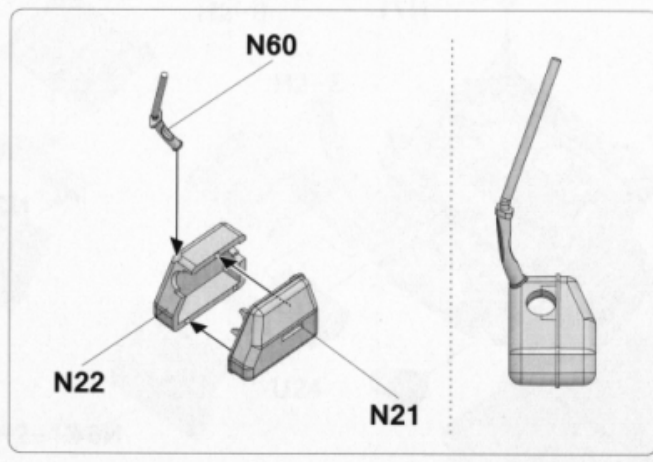
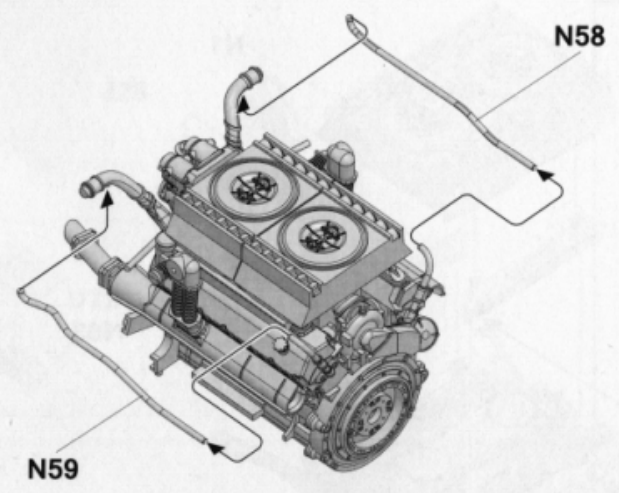

21

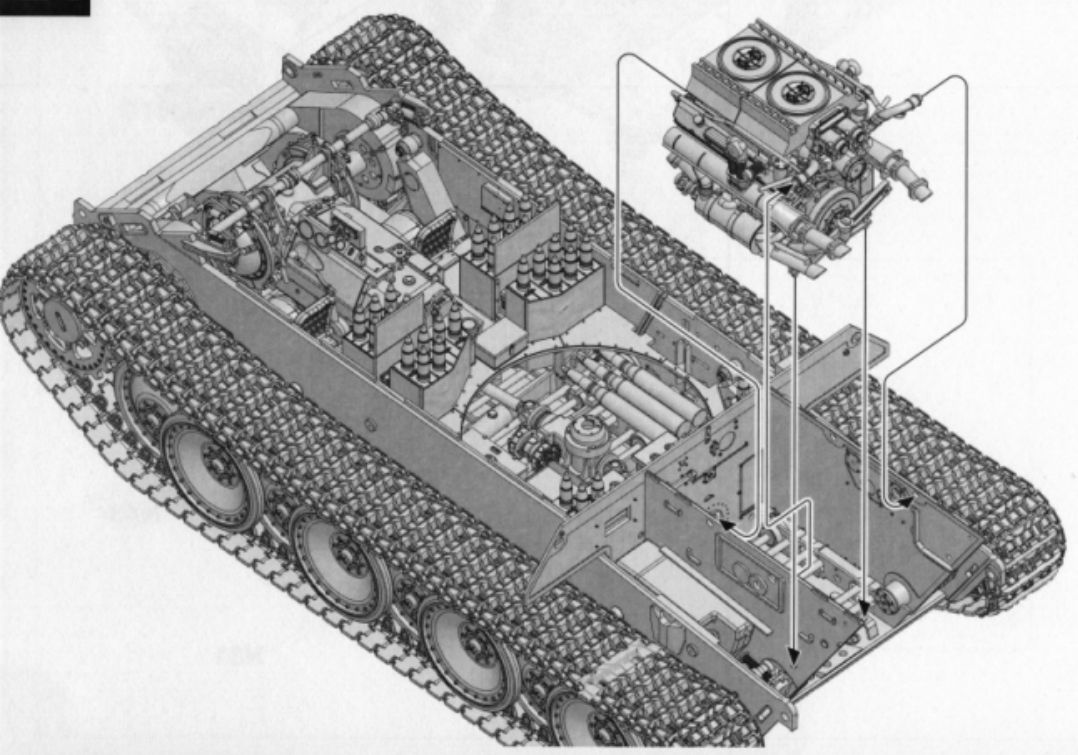

22

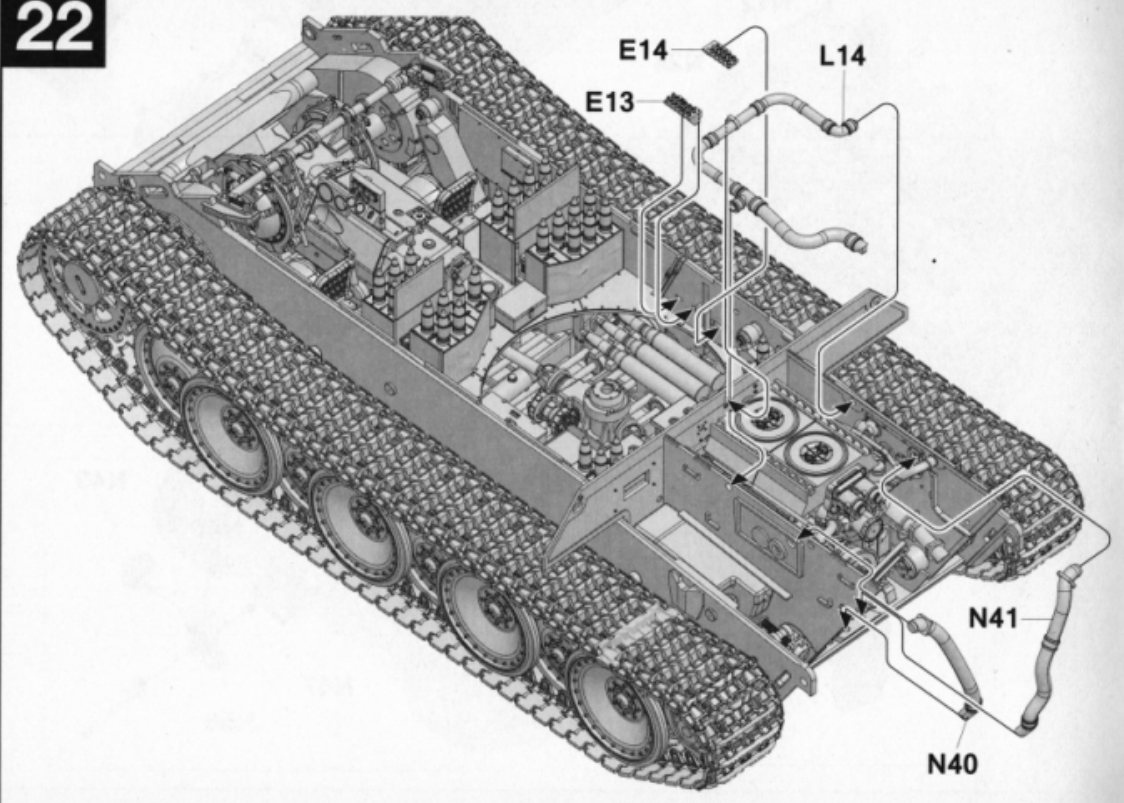



23

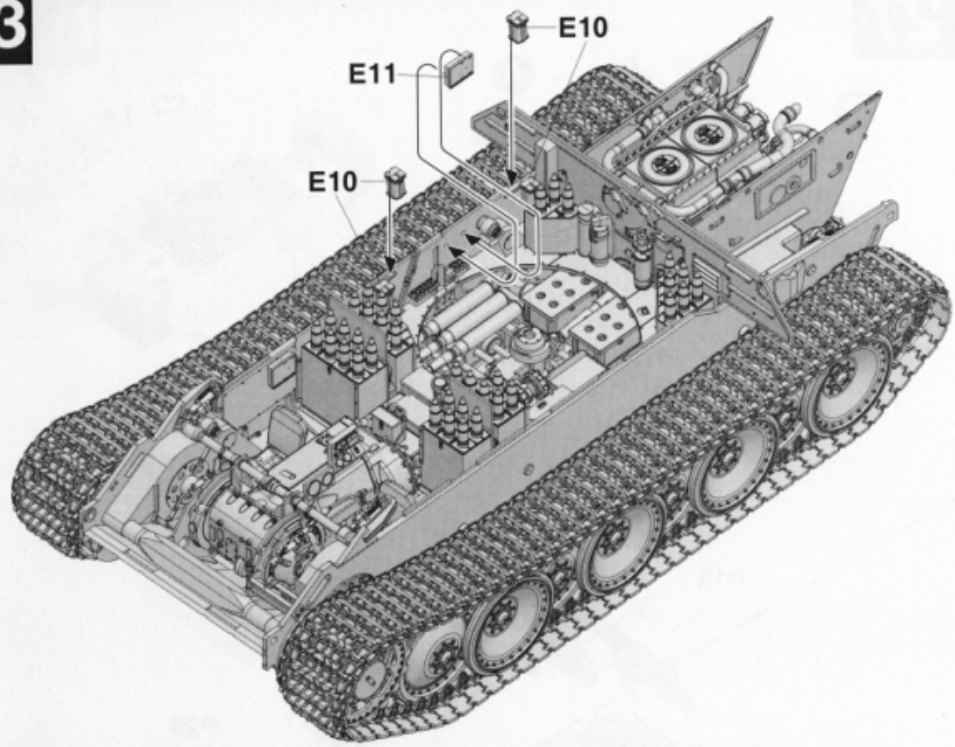

24

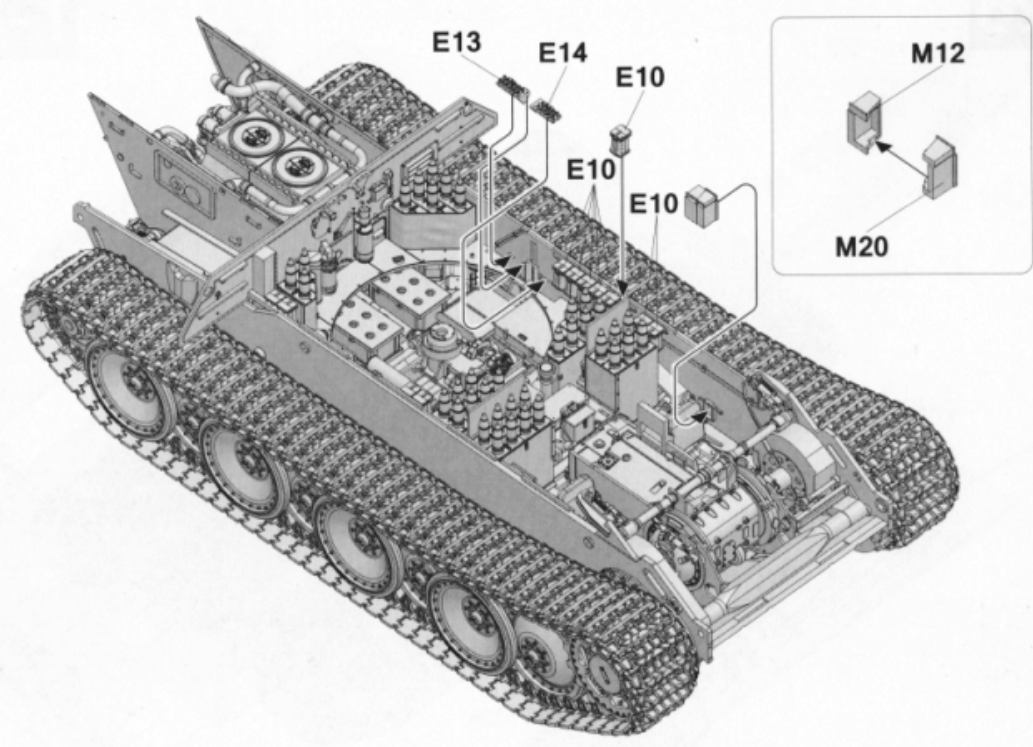

25

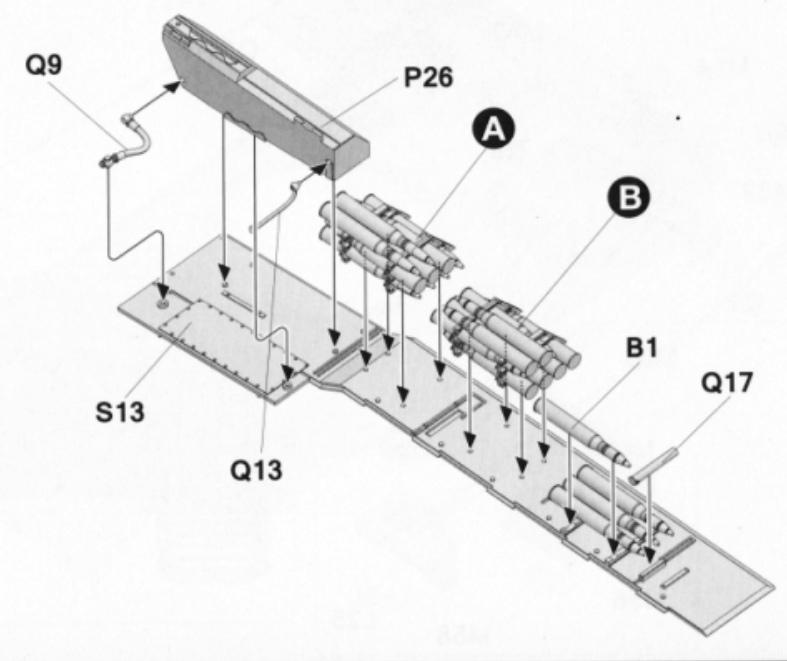
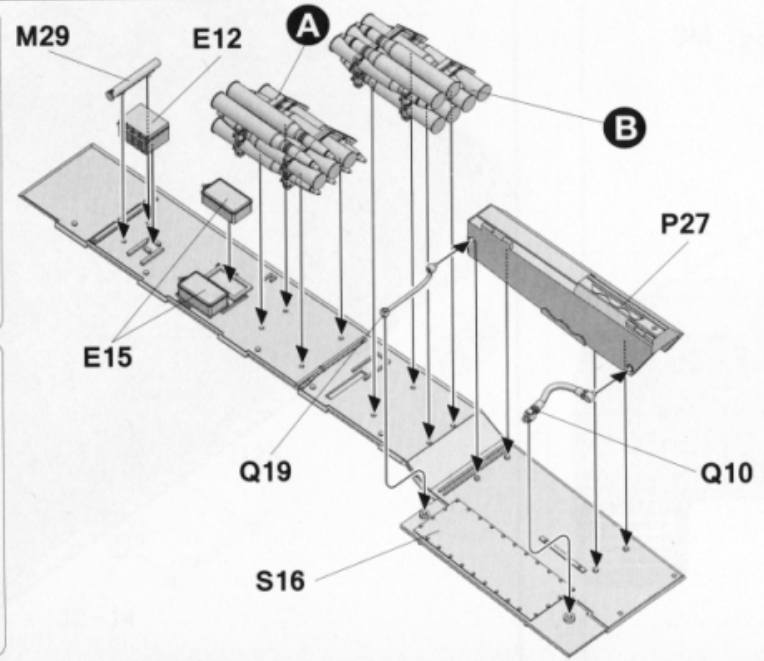
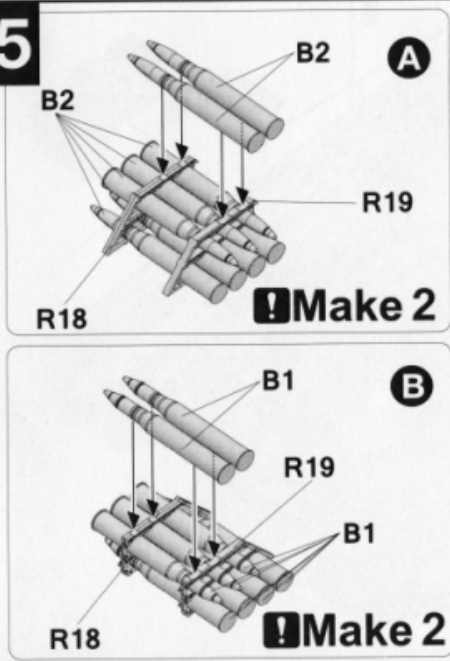



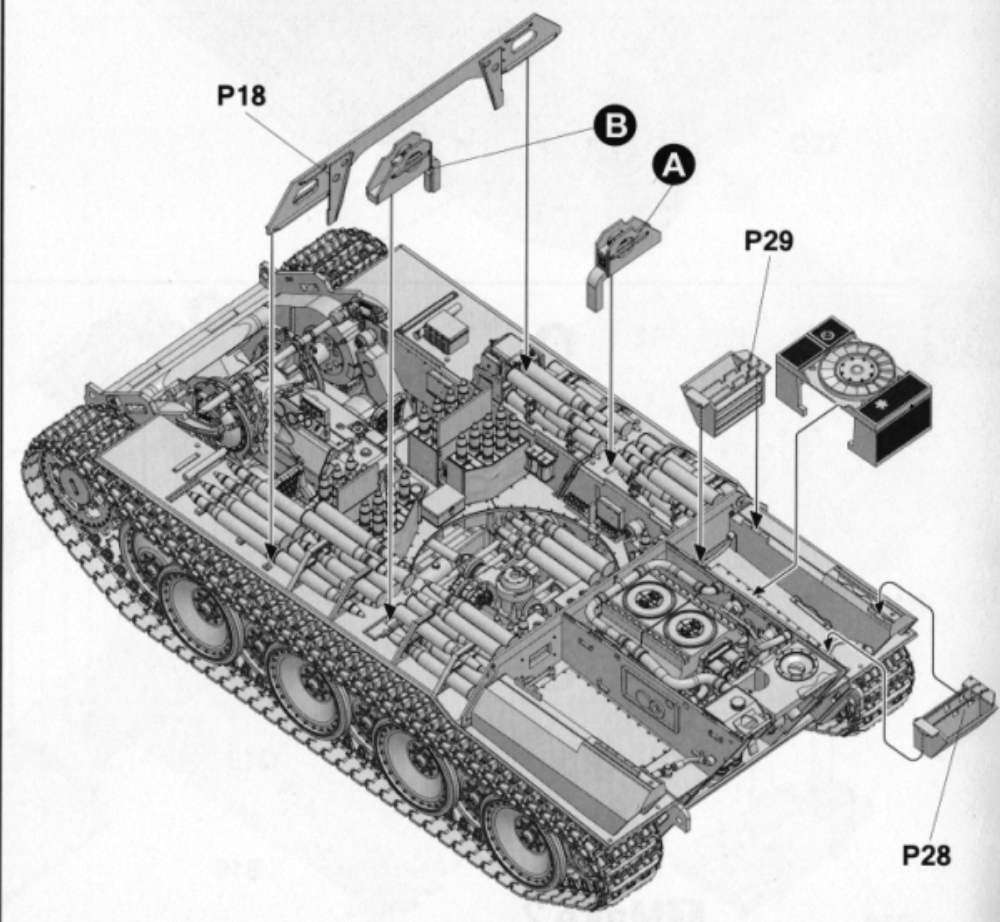
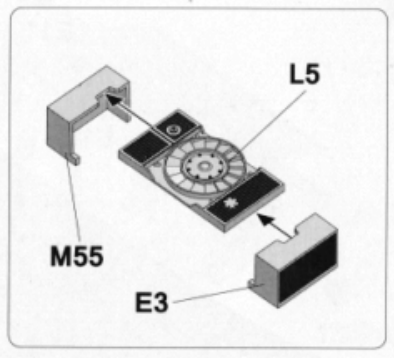
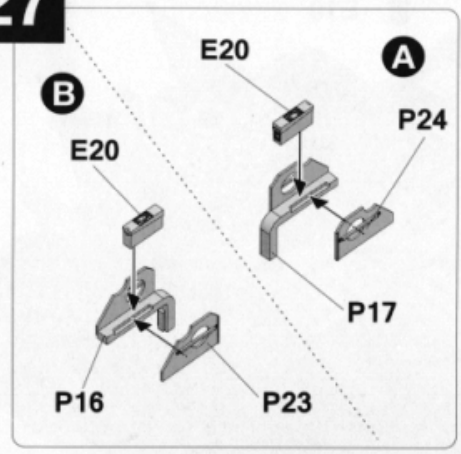
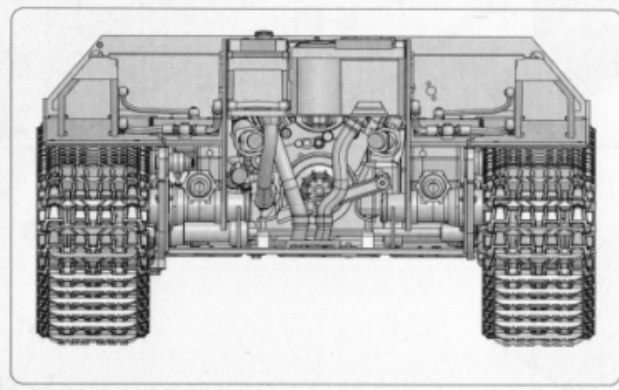
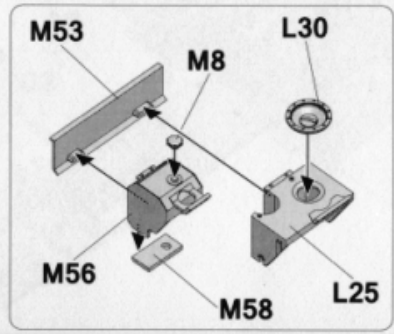
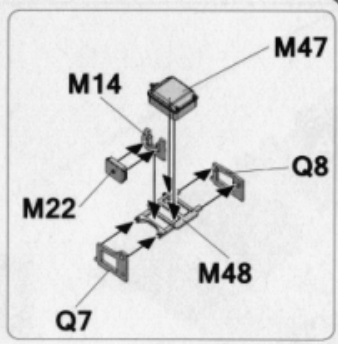
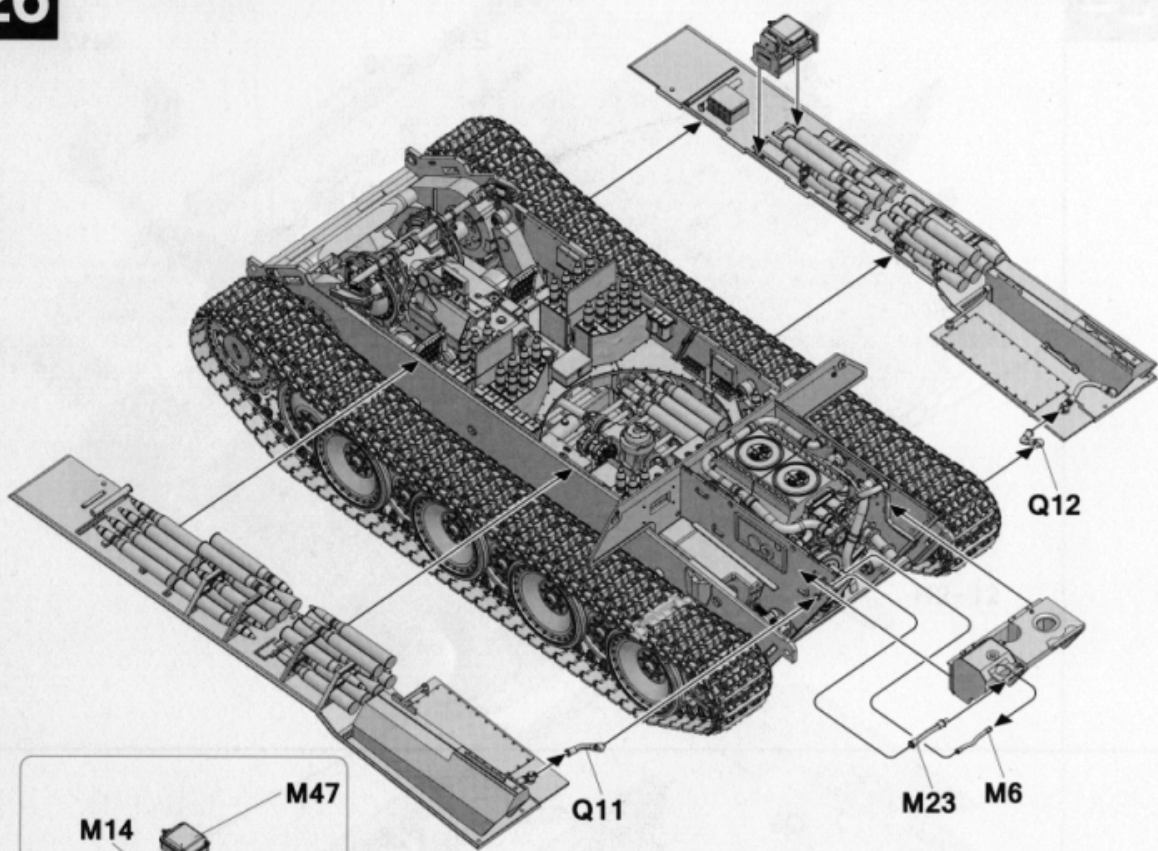

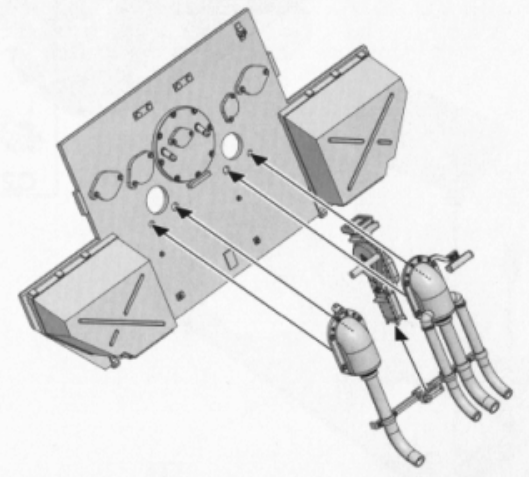
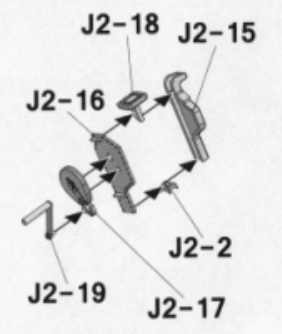
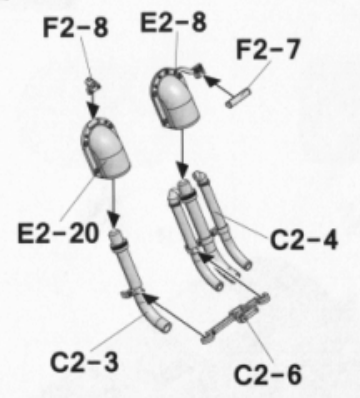
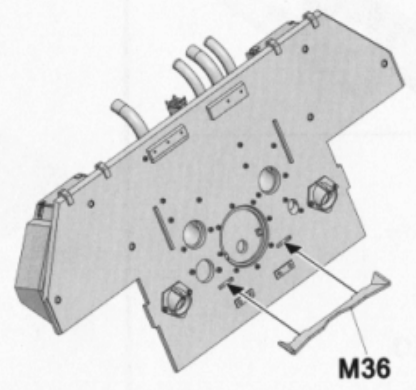
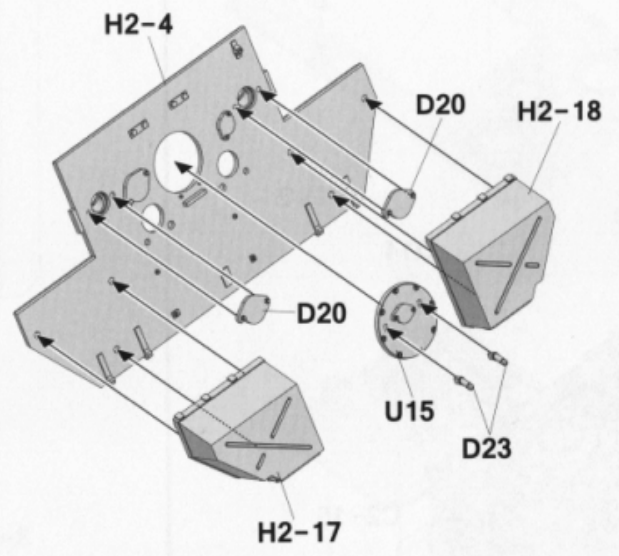
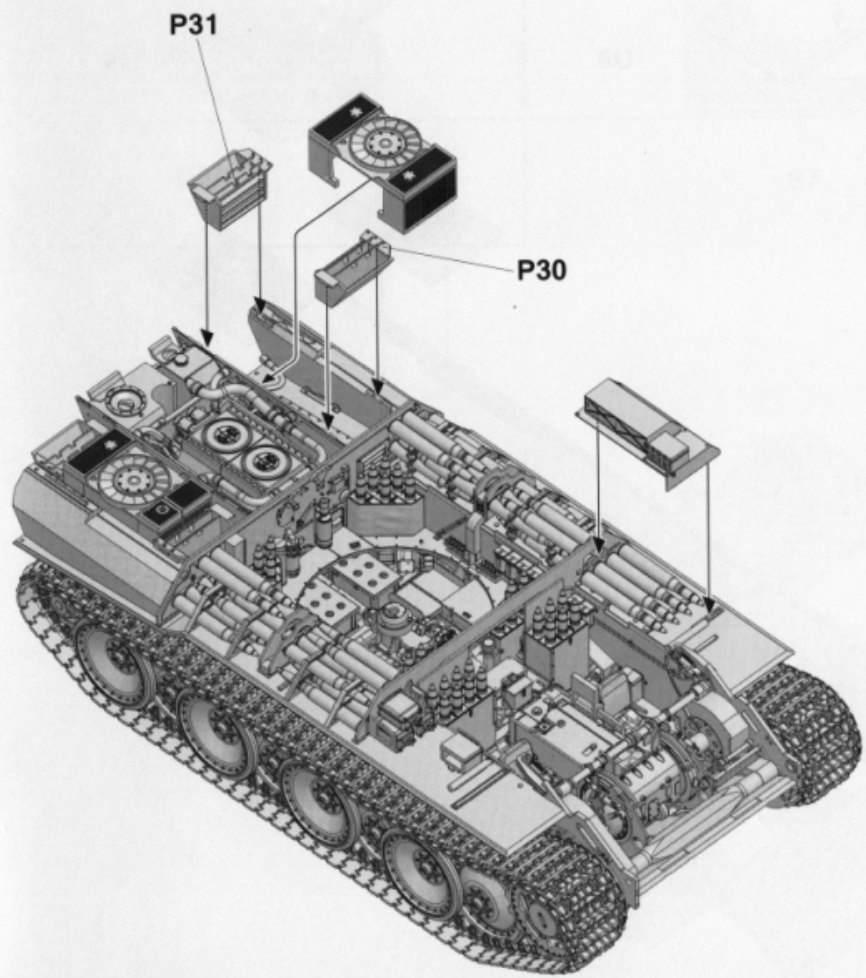
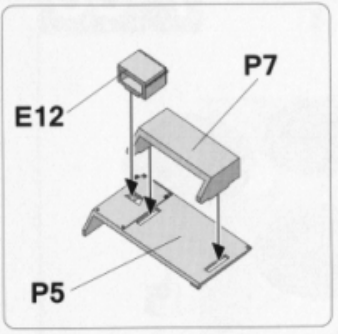
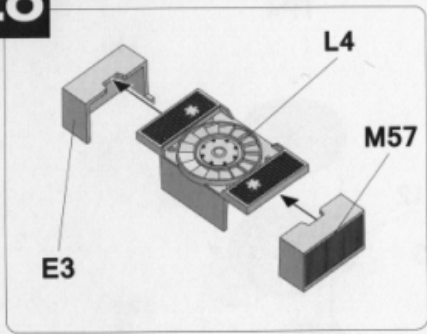



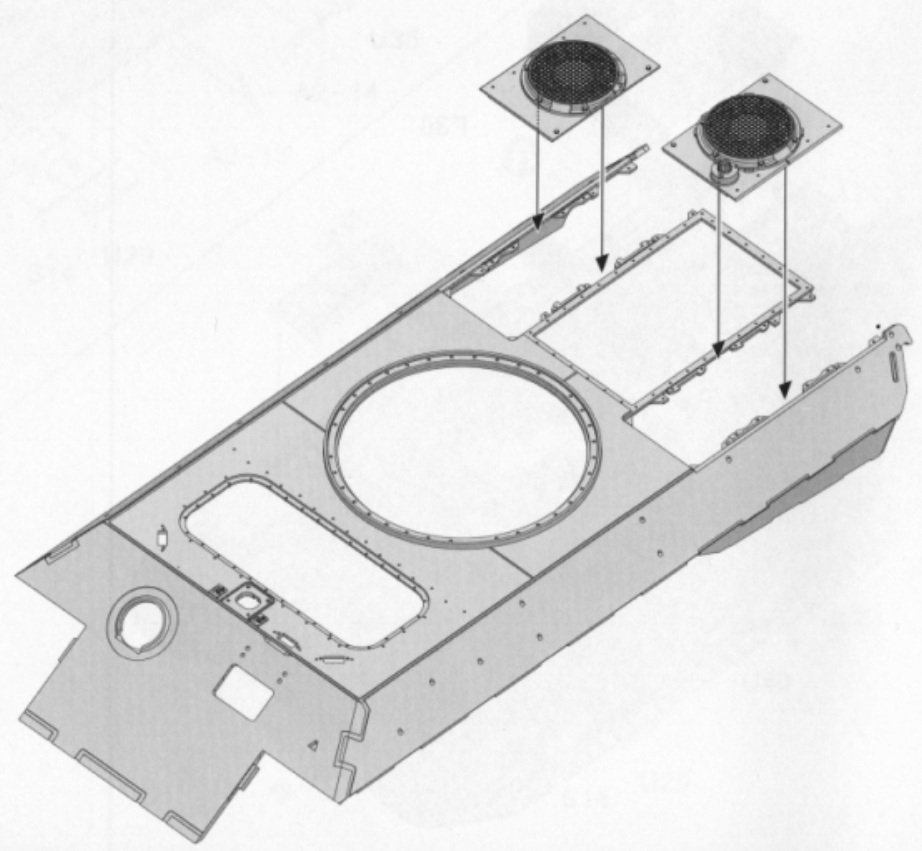
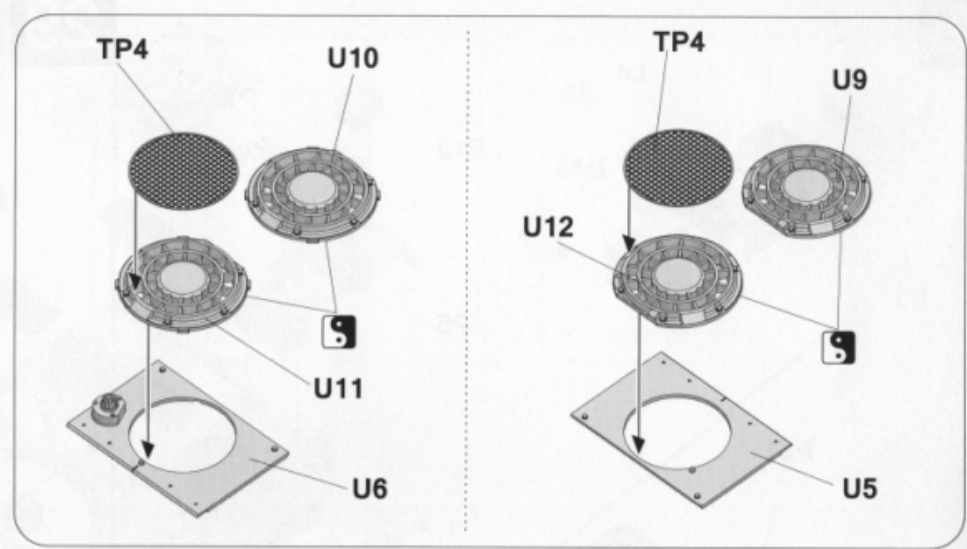
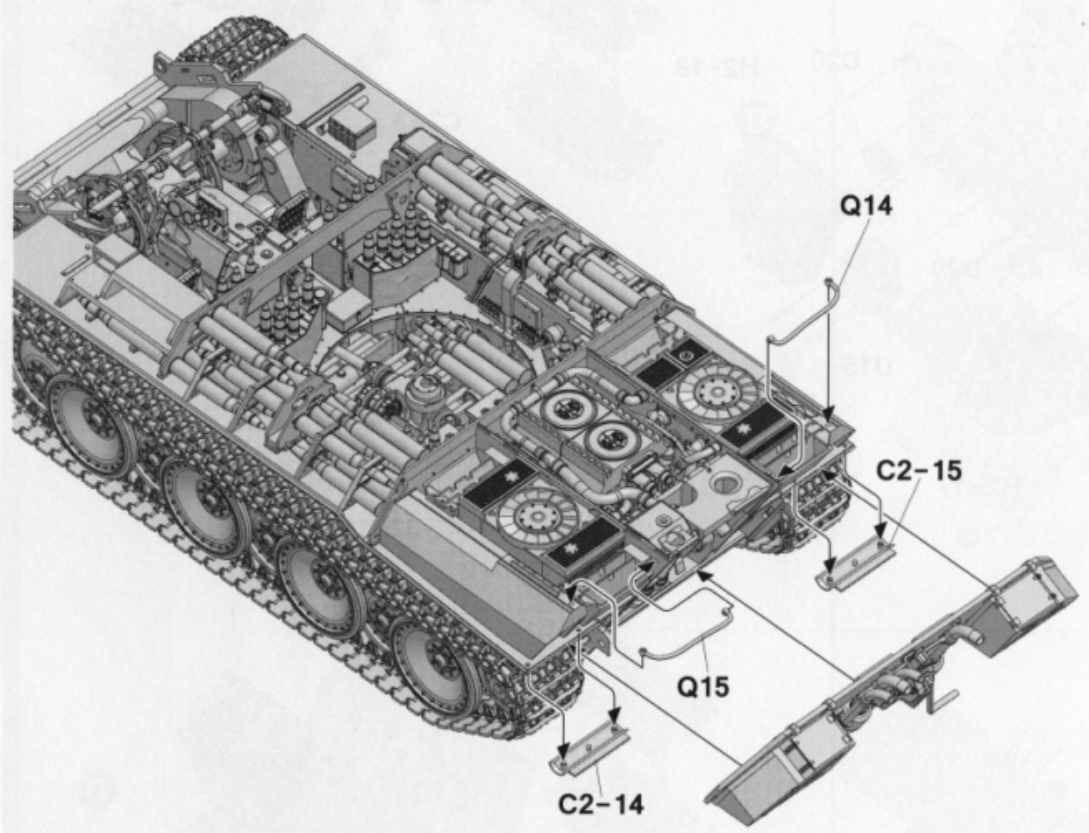



# 32

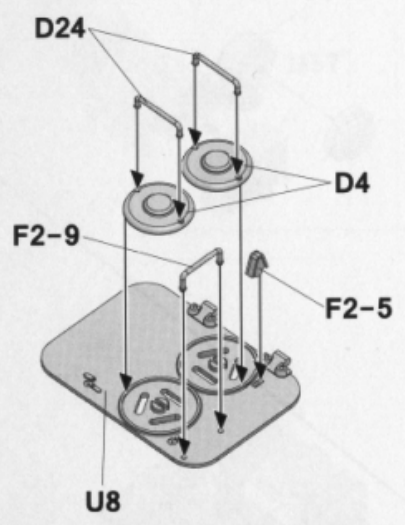

# 33-1

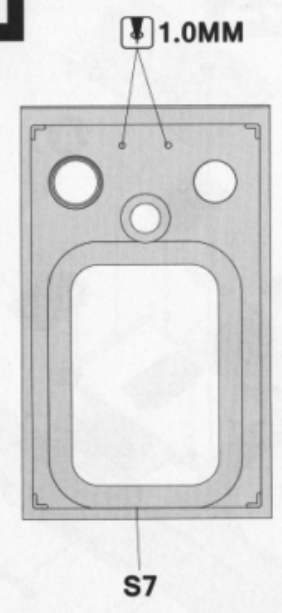

# 33-2

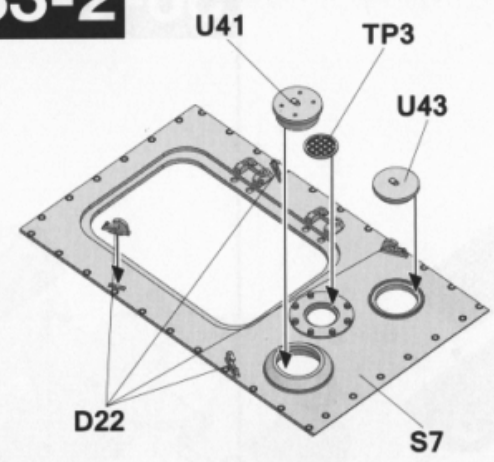

# 34

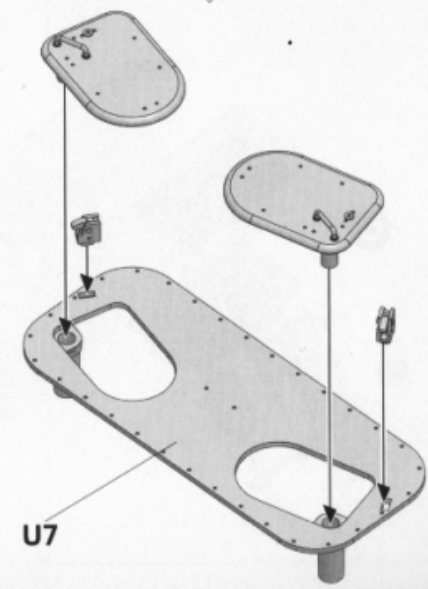
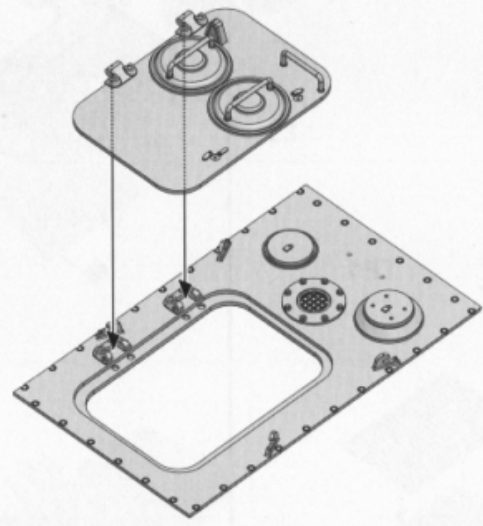
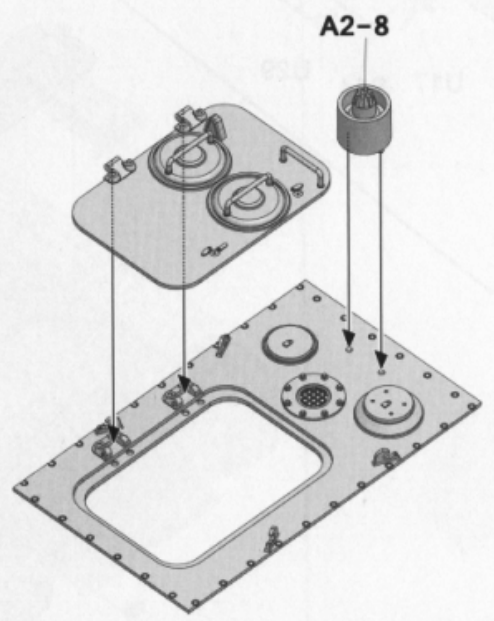
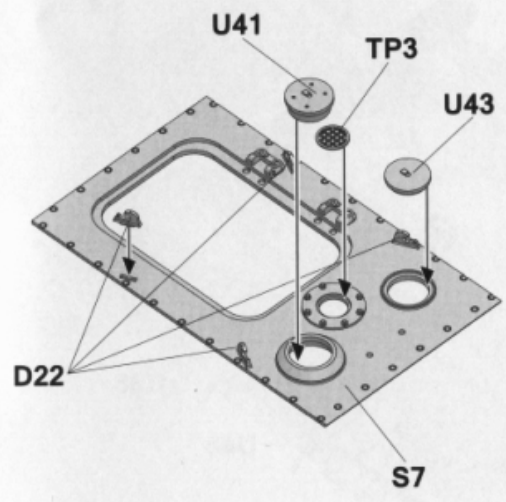
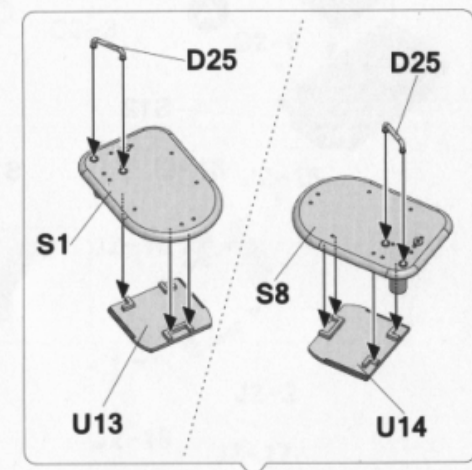
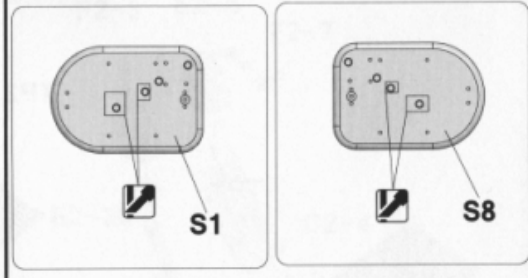



35

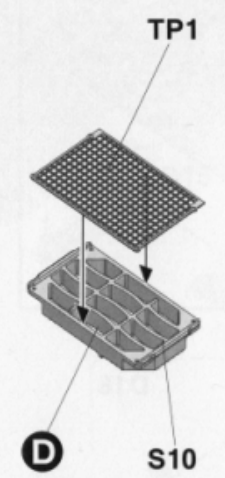
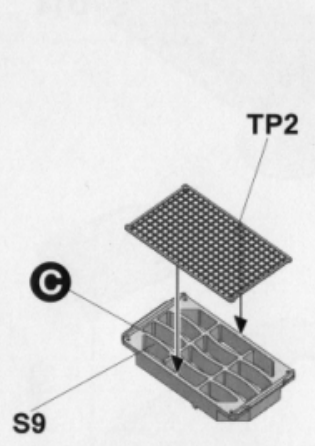
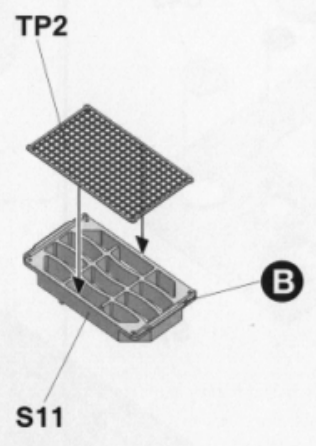
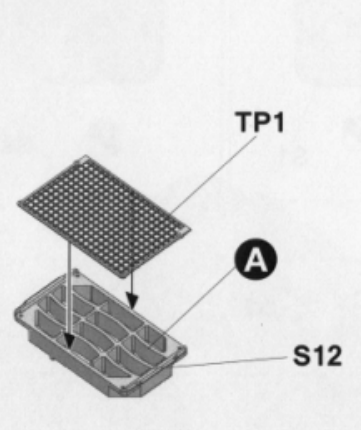

36-1

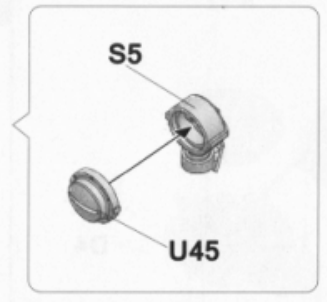
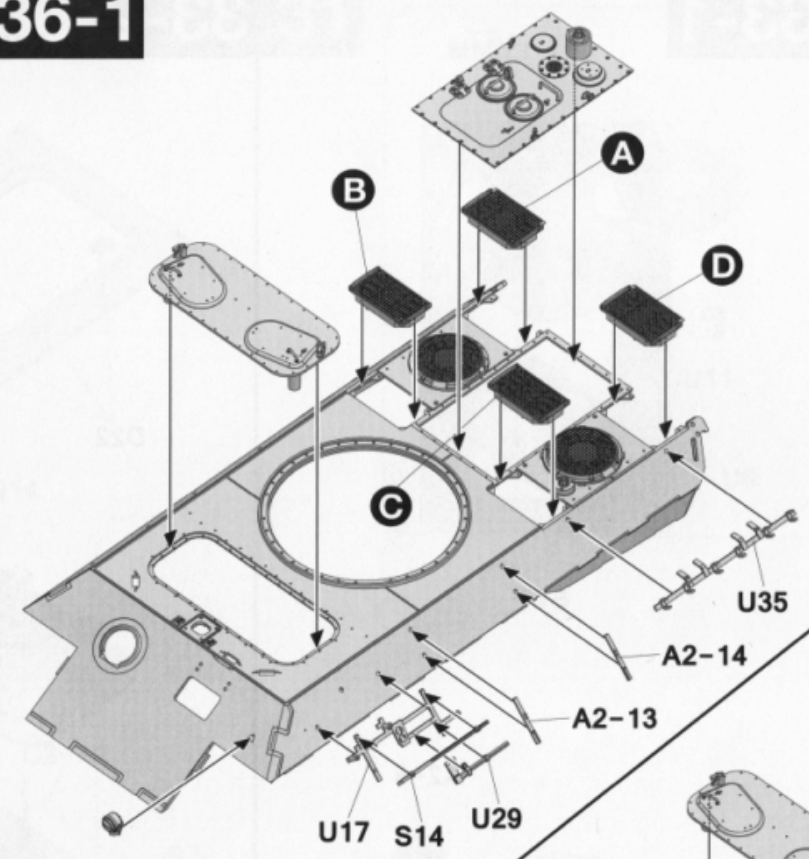

36-2

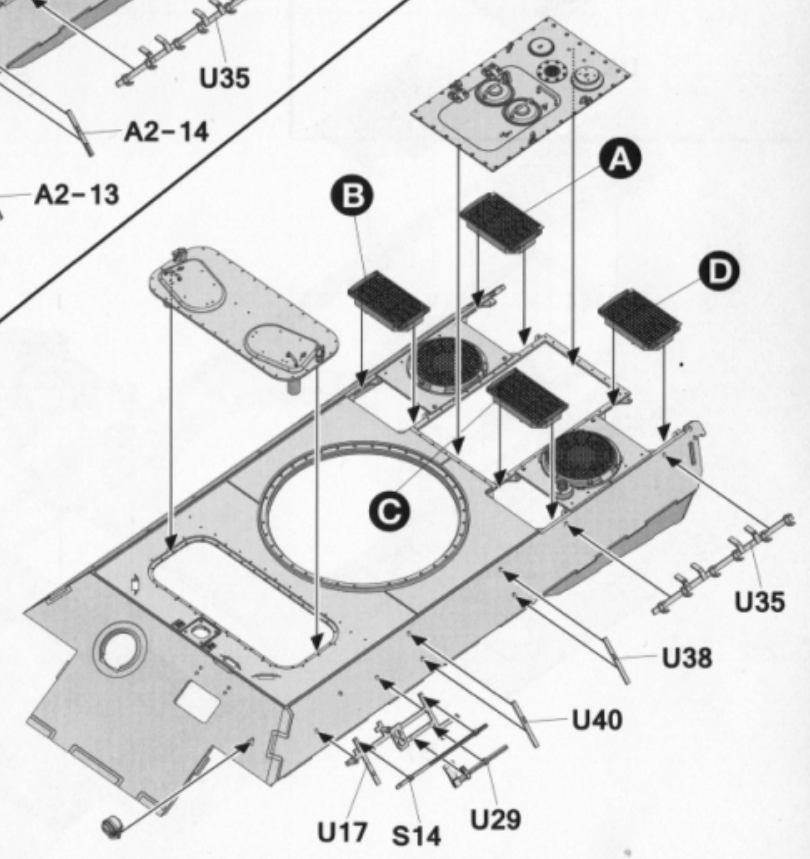



**37-1**

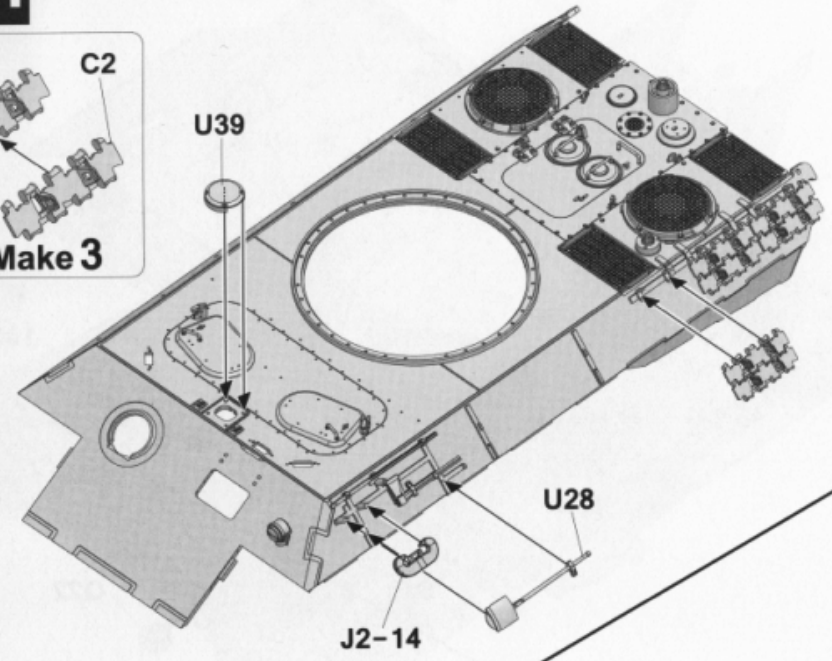
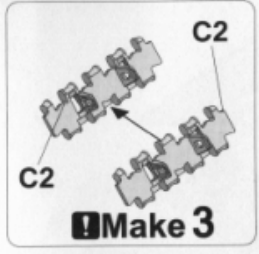

**37-2**

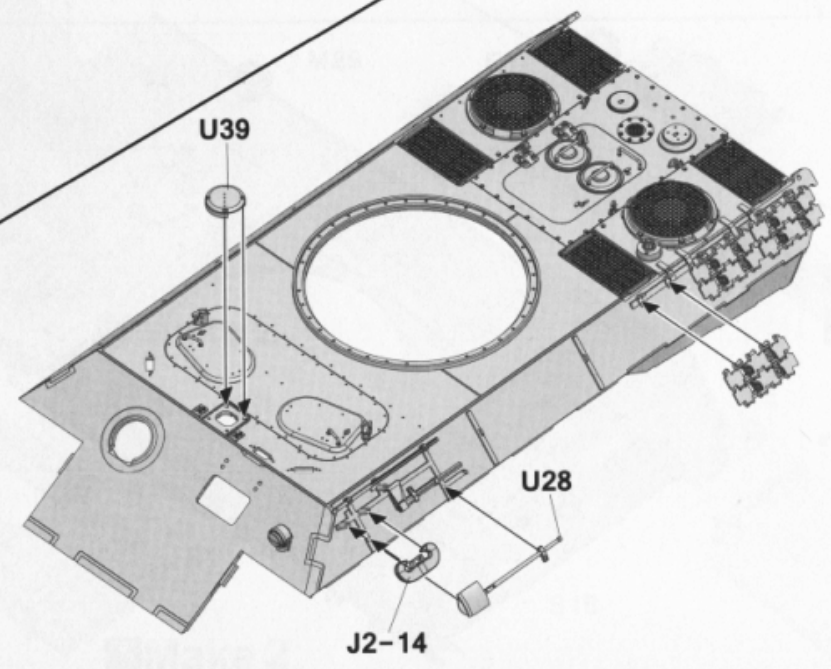

**38-1**

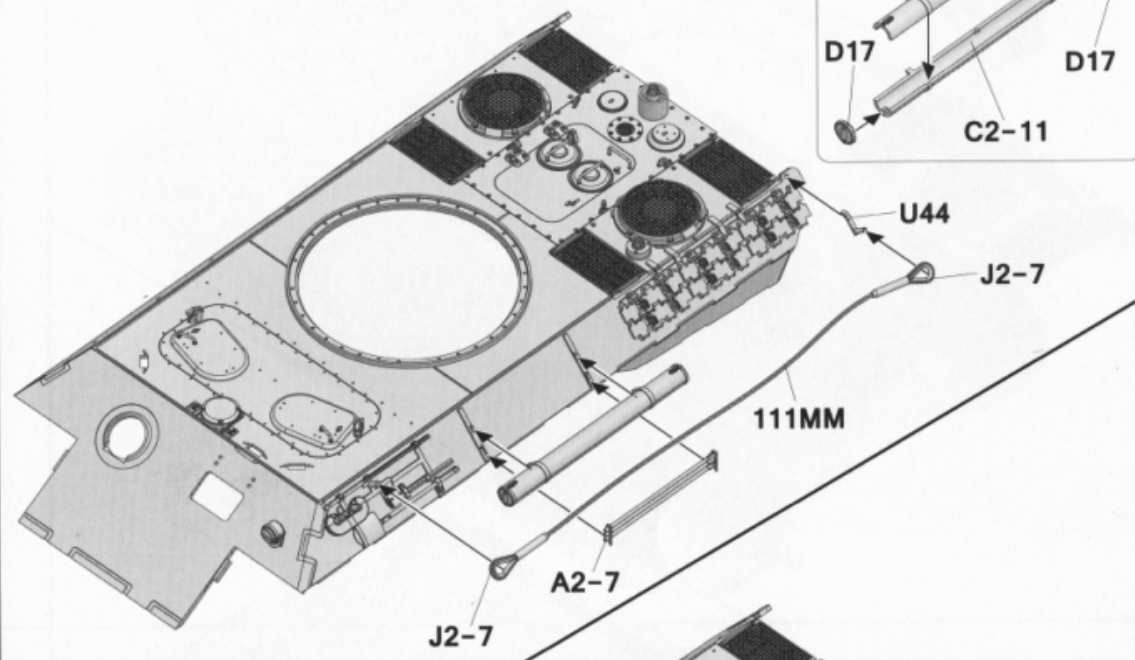
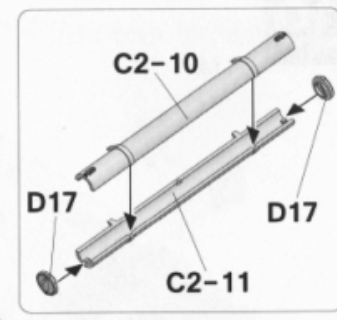

**38-2**

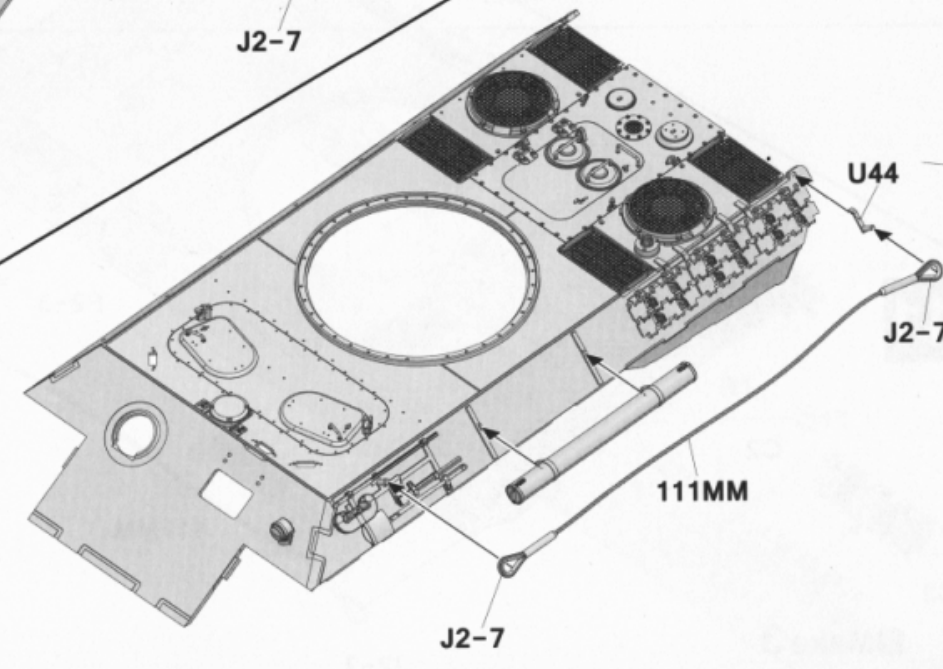



39

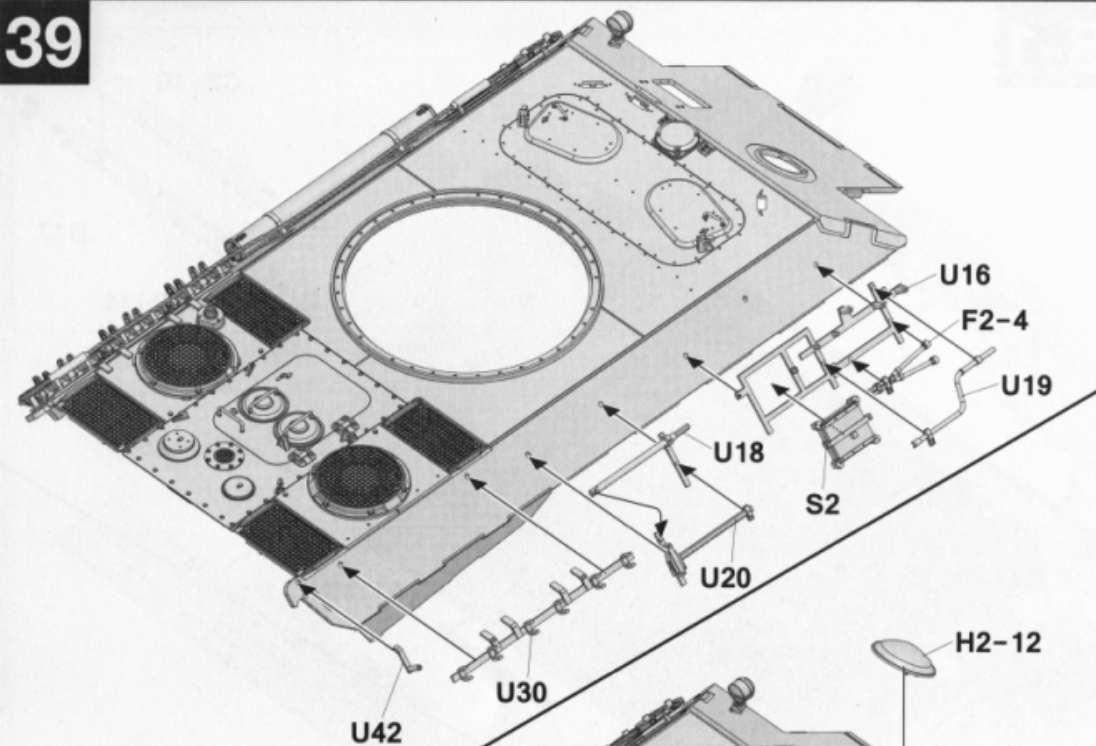

40

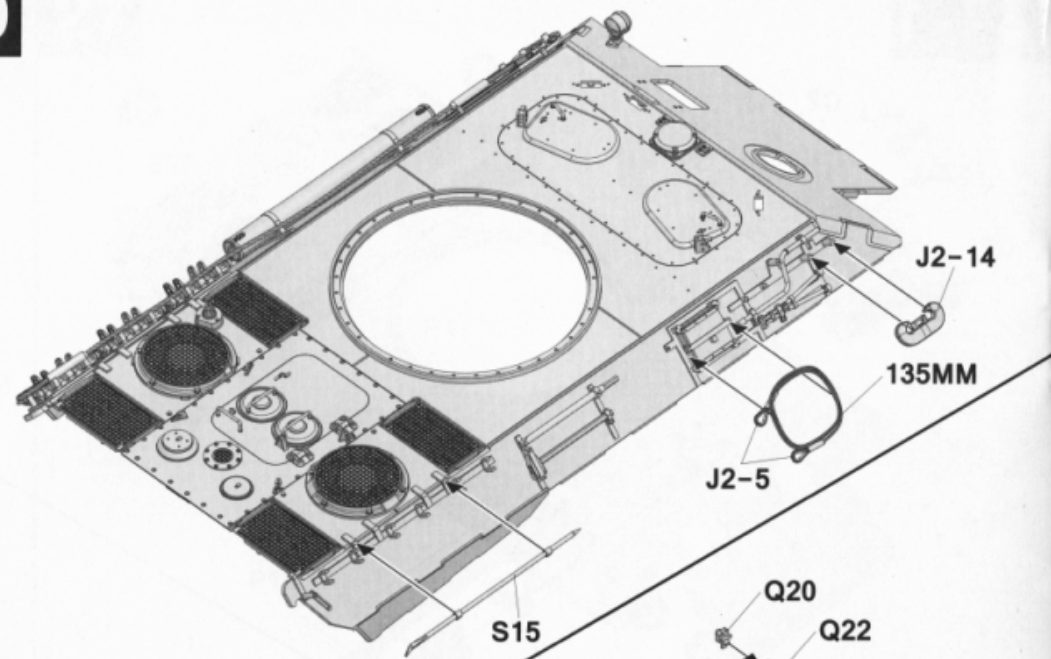

41

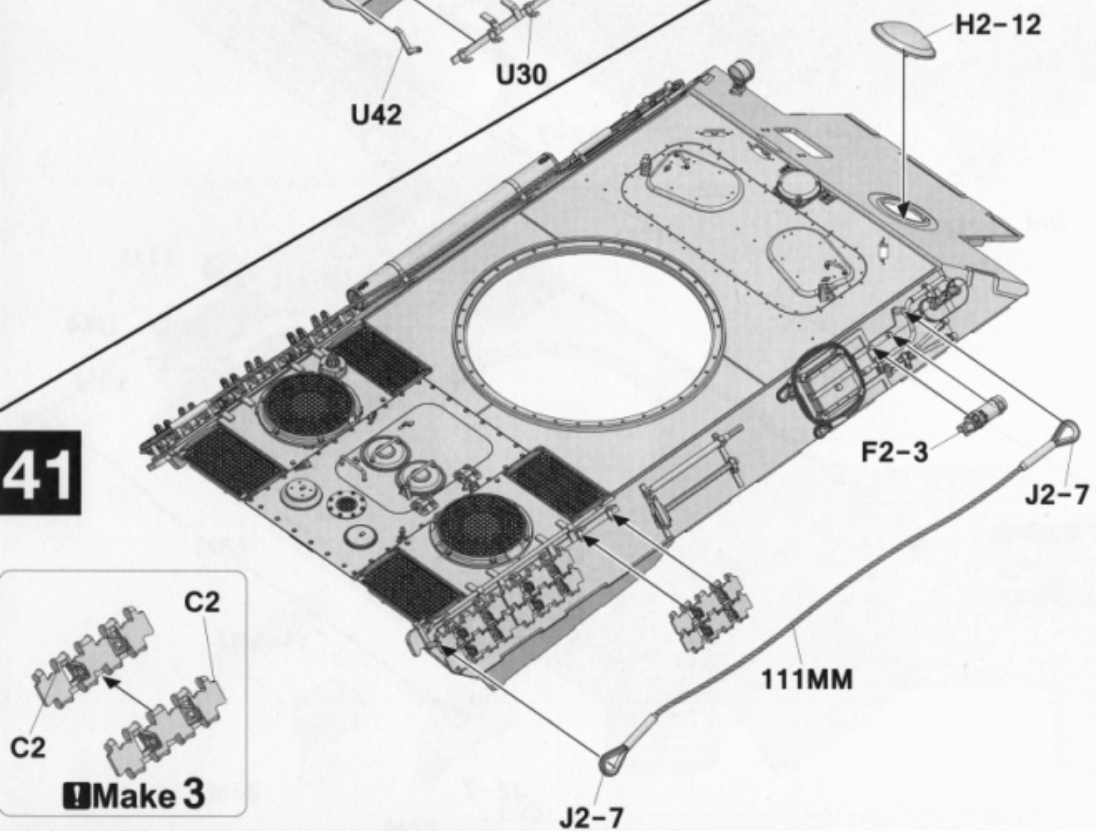

42

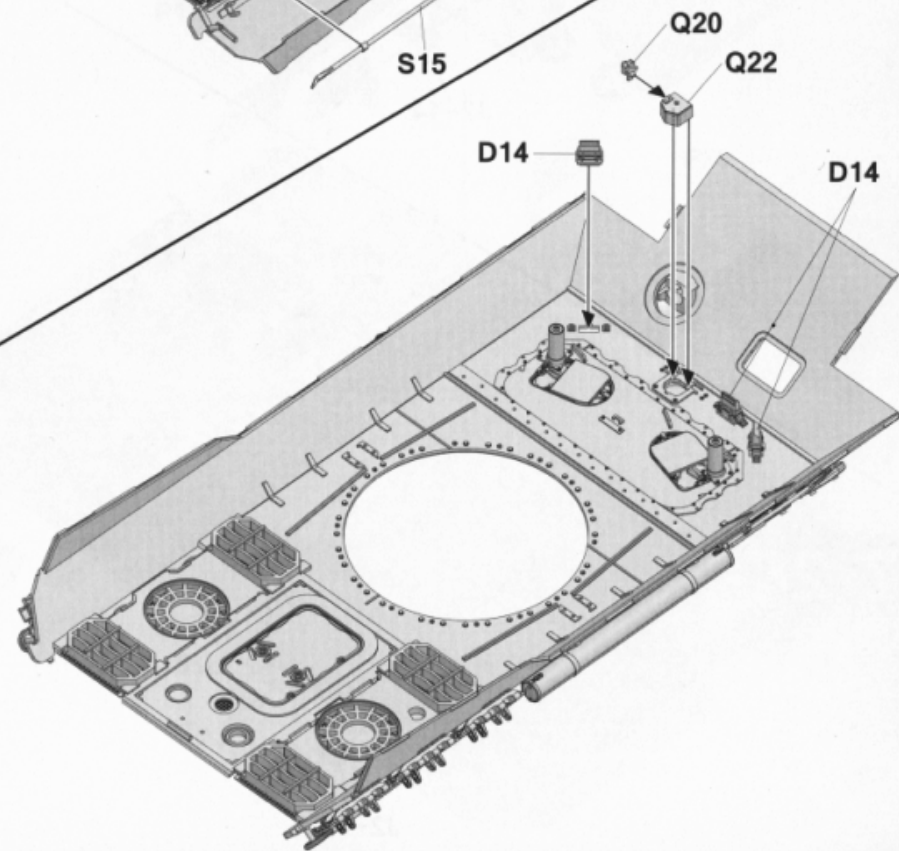

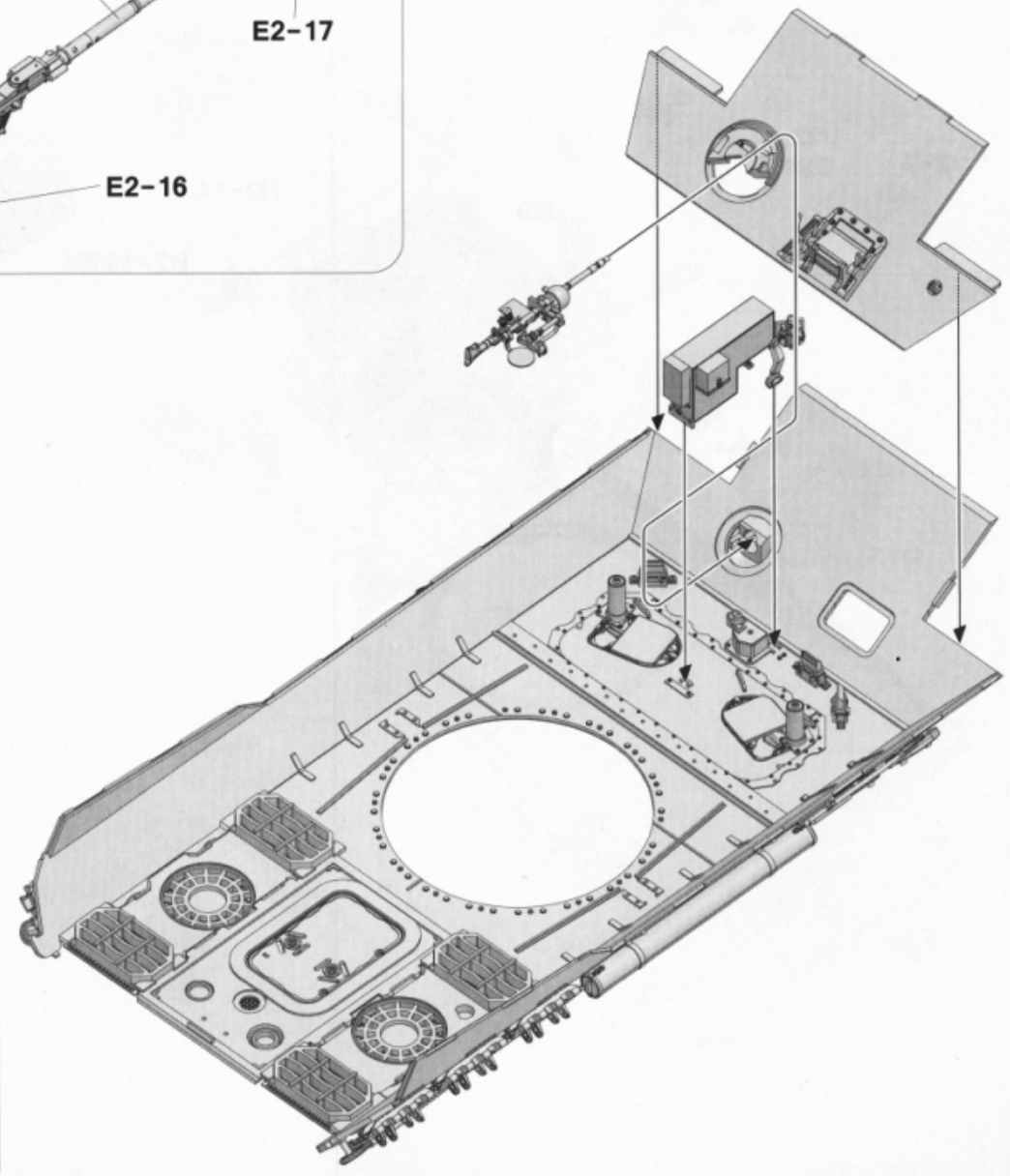
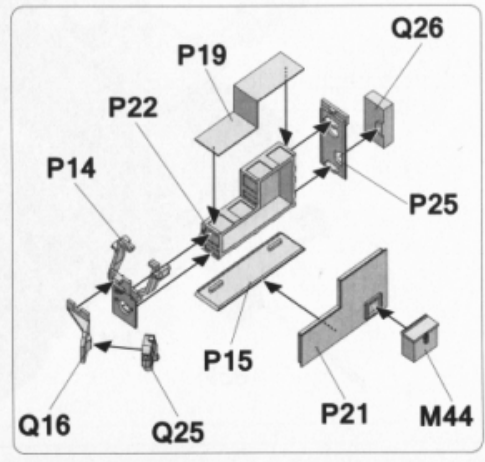
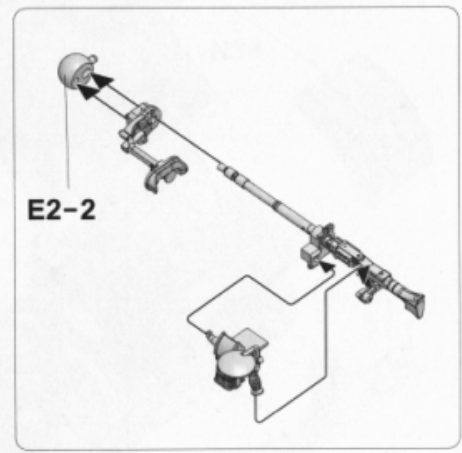
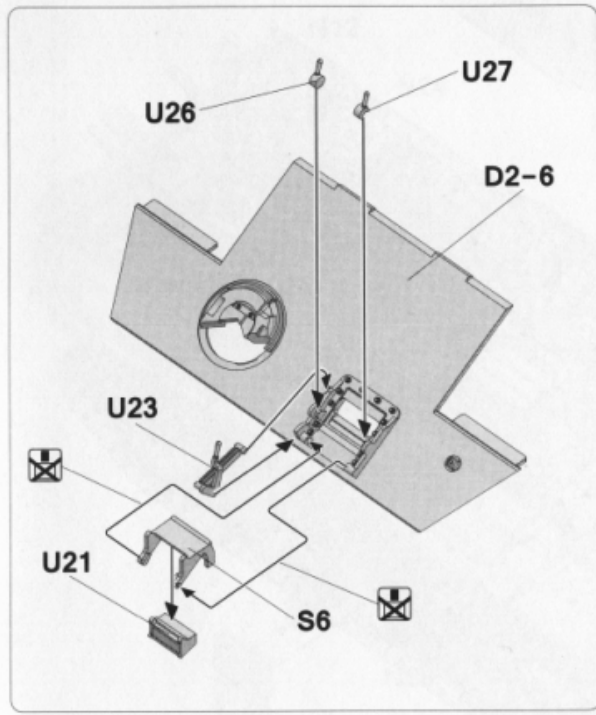
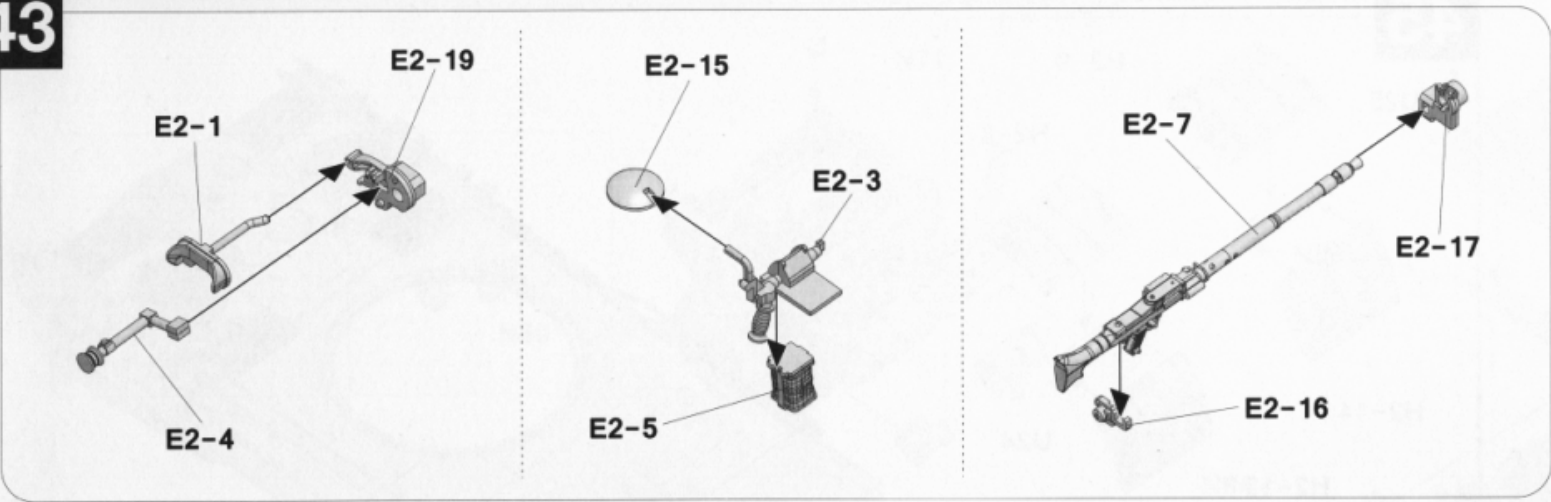



44

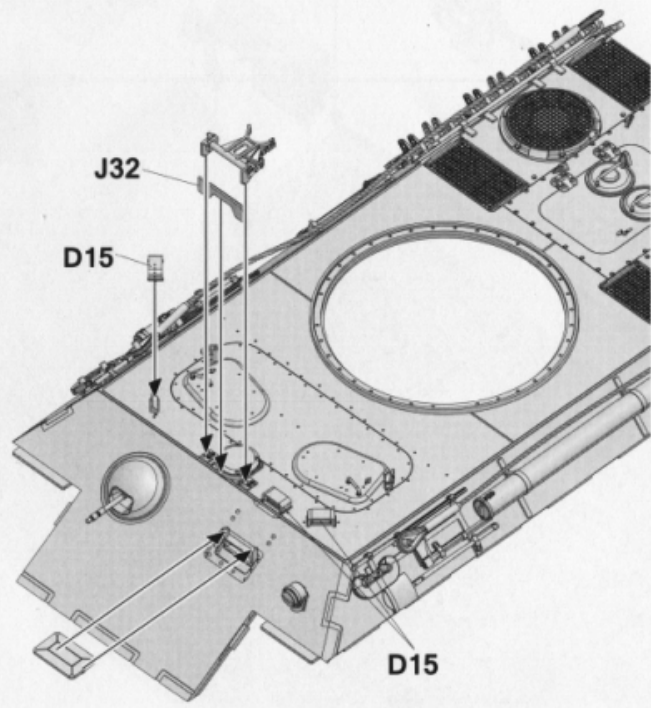
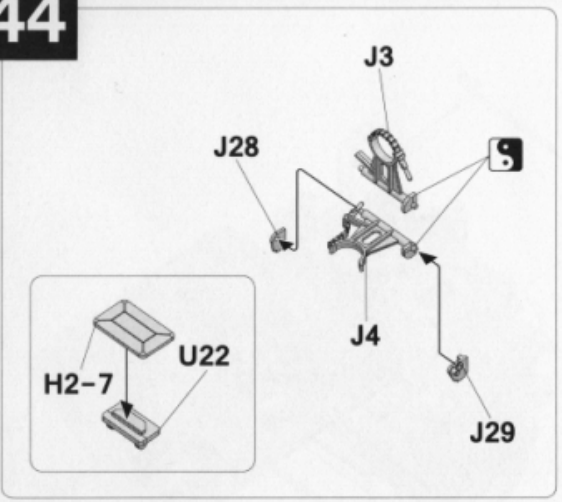

45

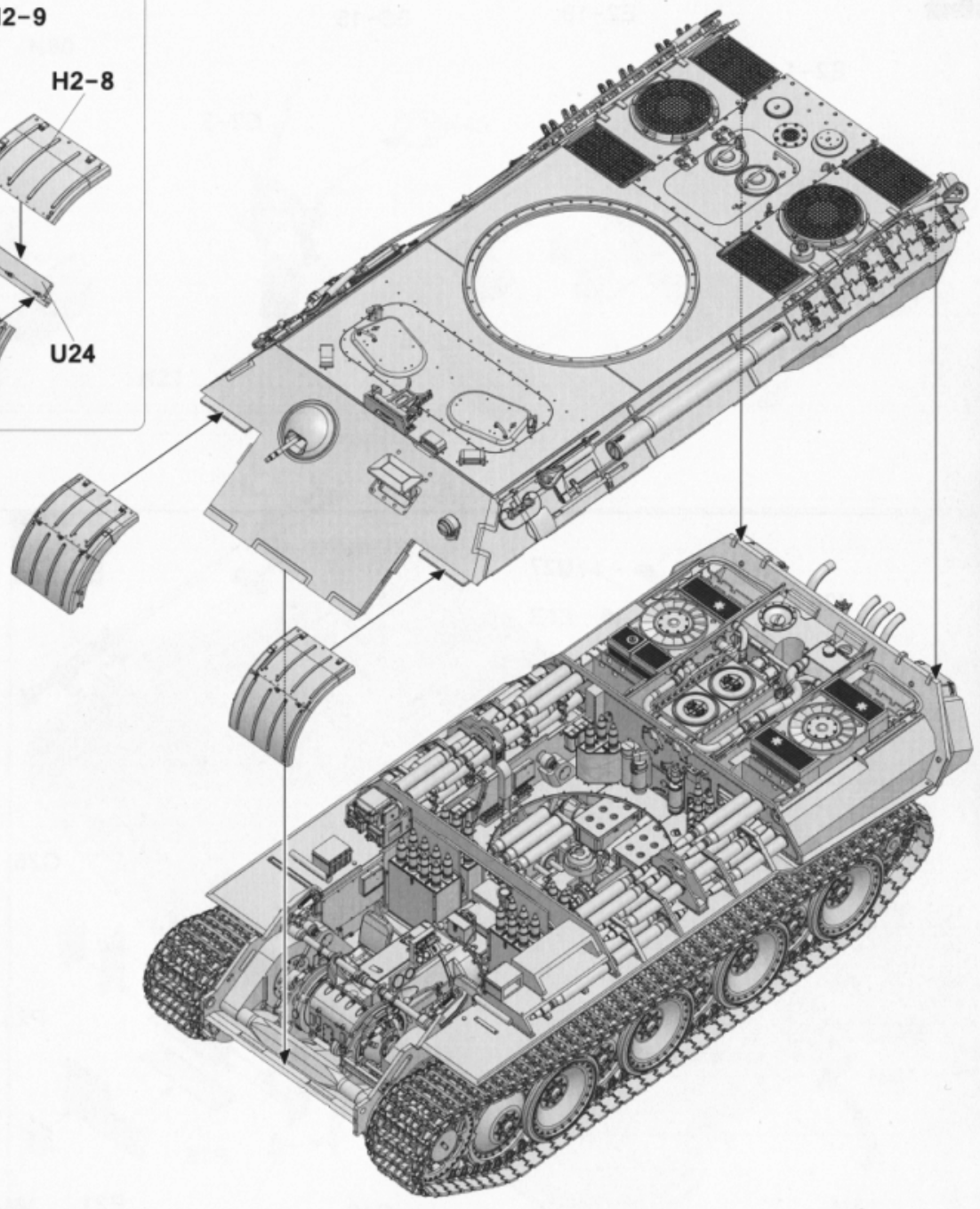
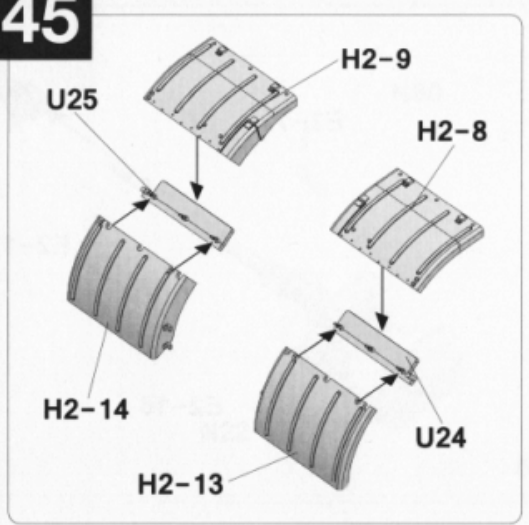

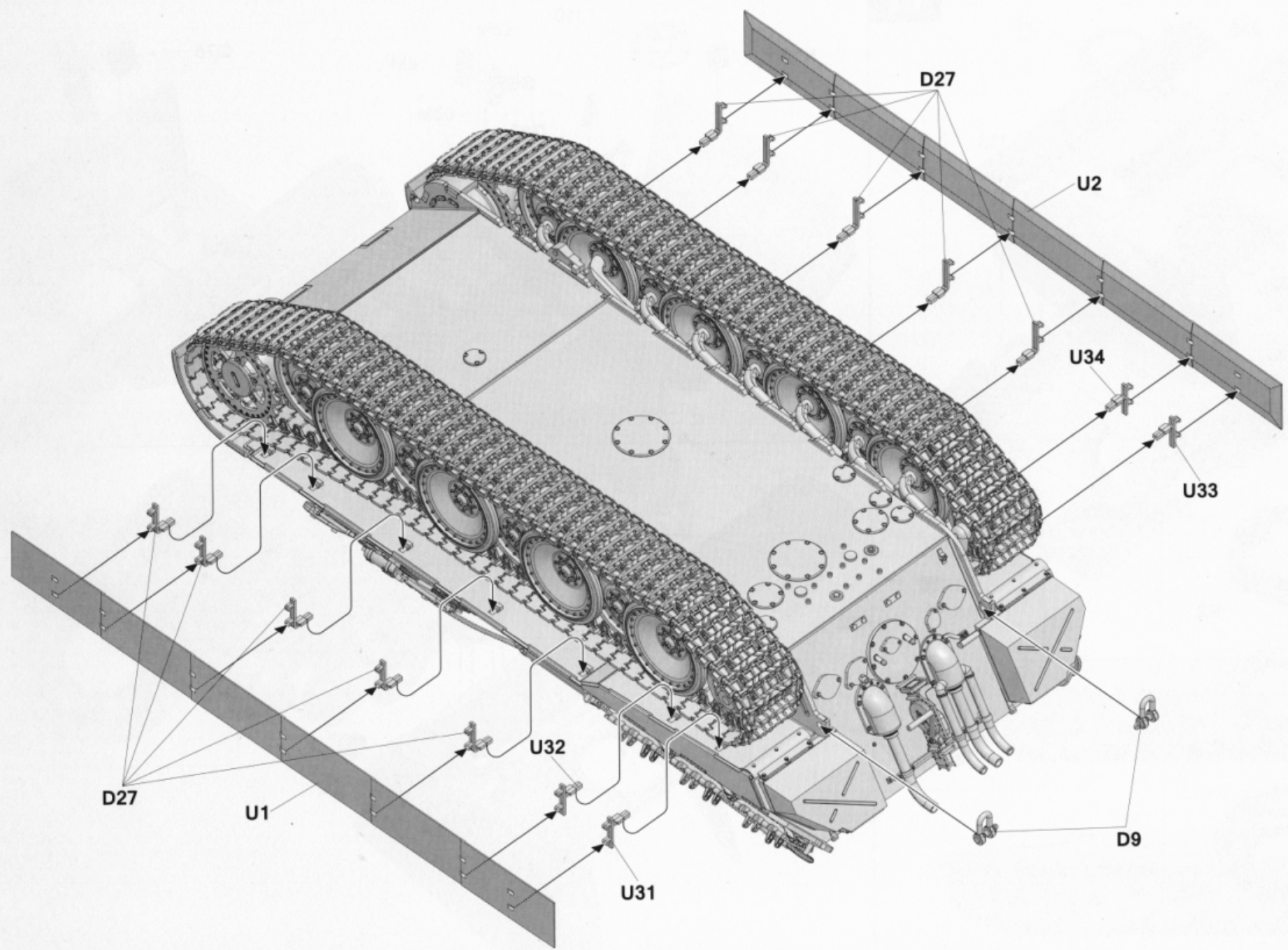



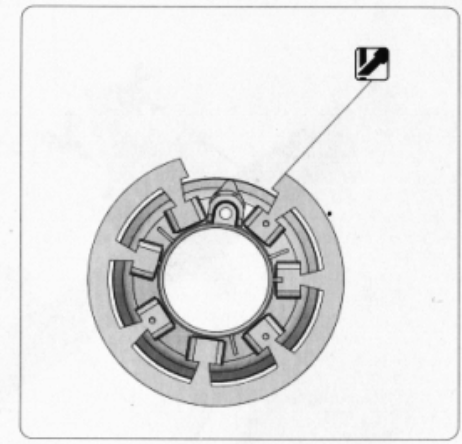
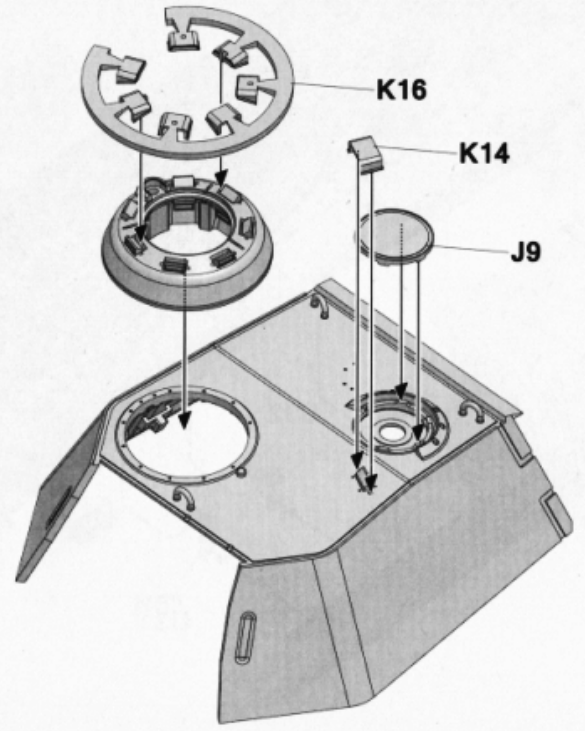
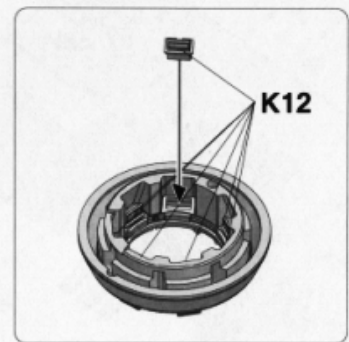
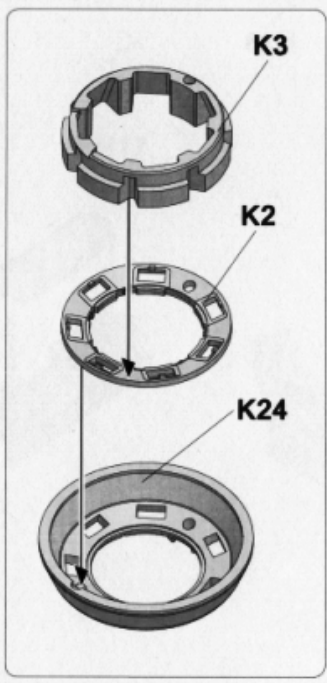
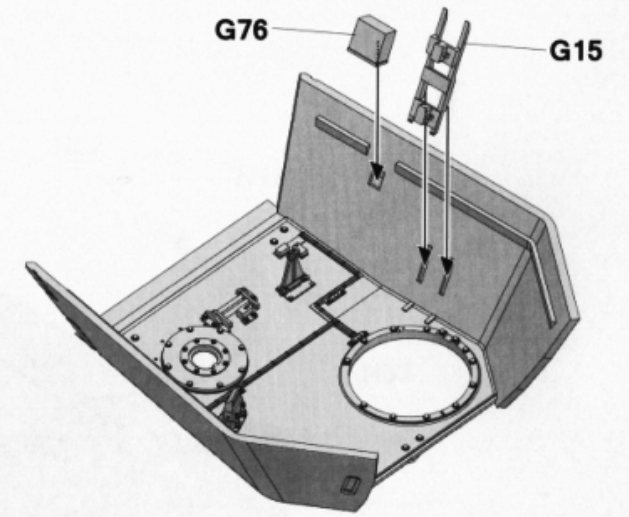
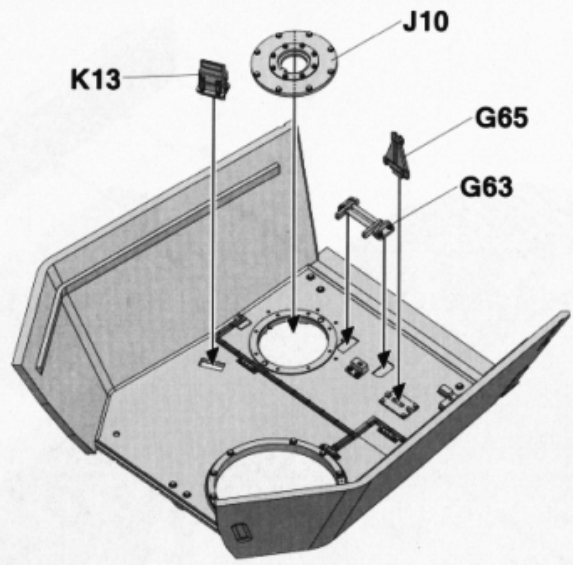
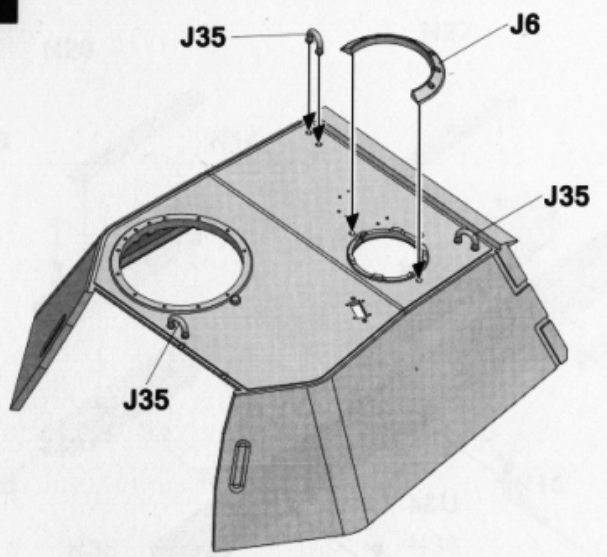

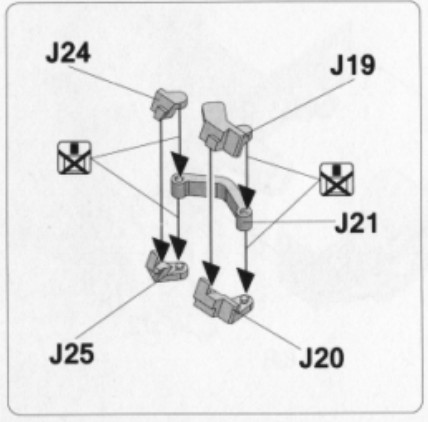
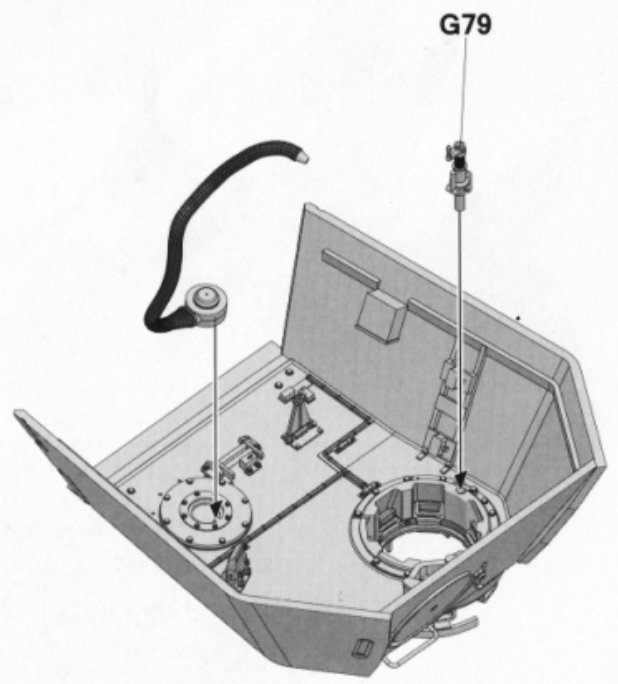
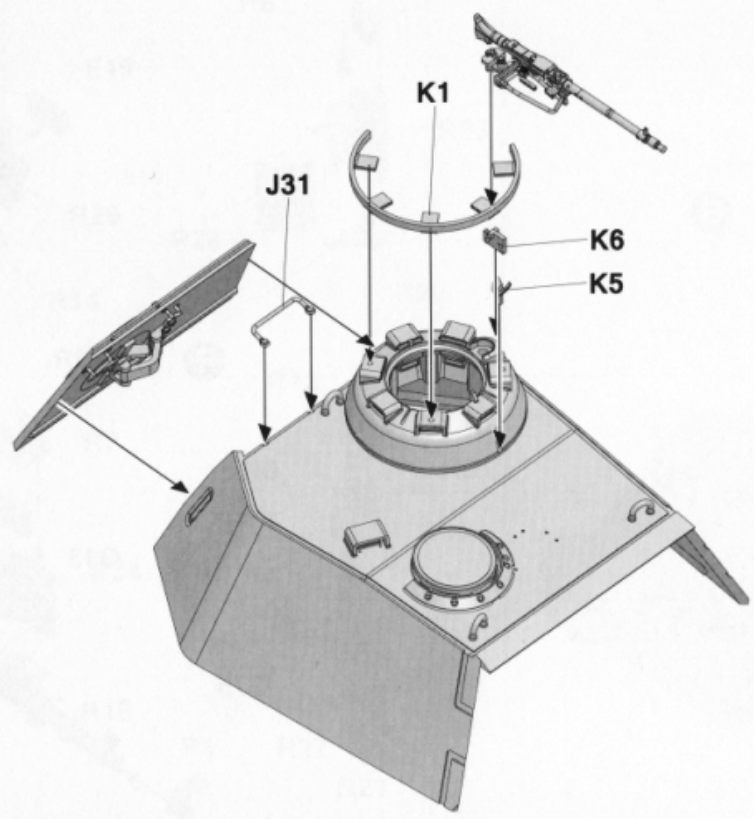
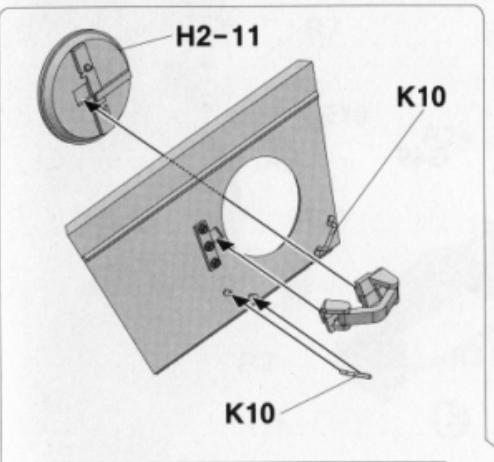
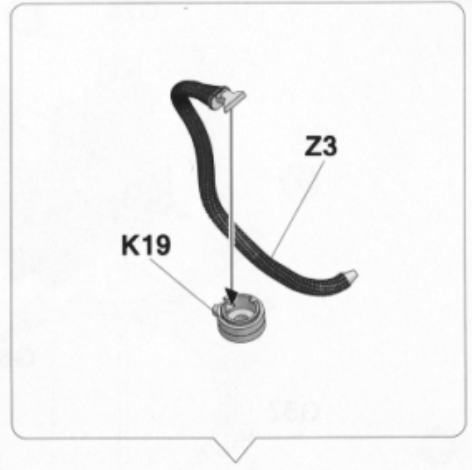
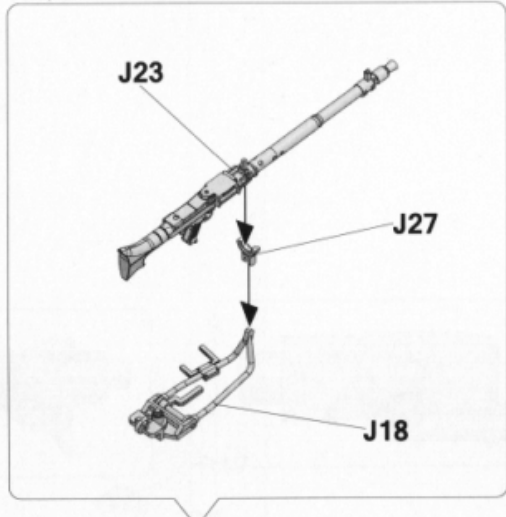
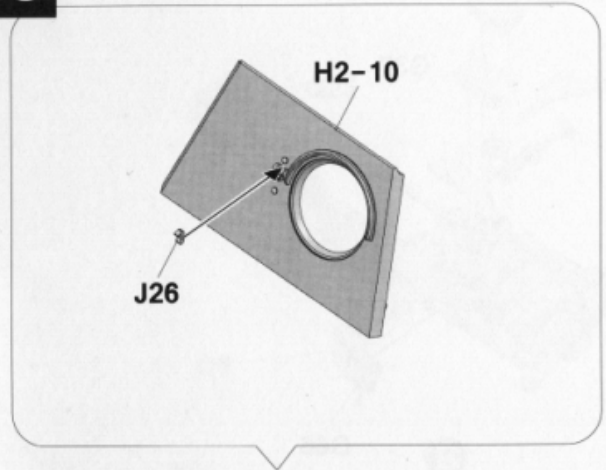



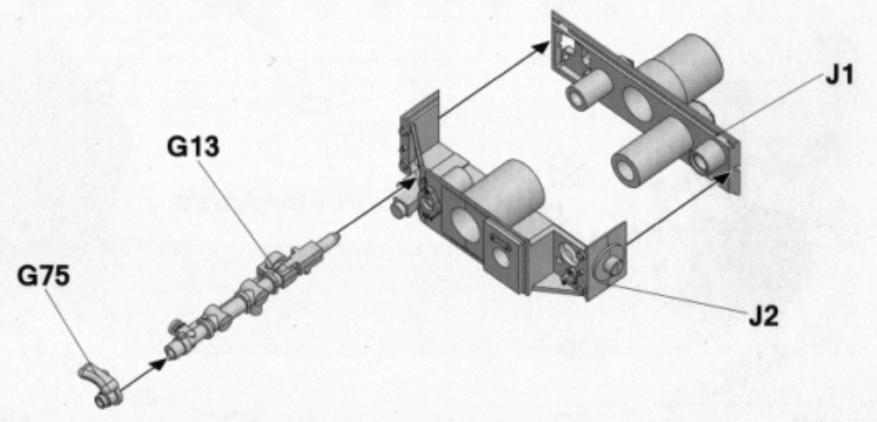
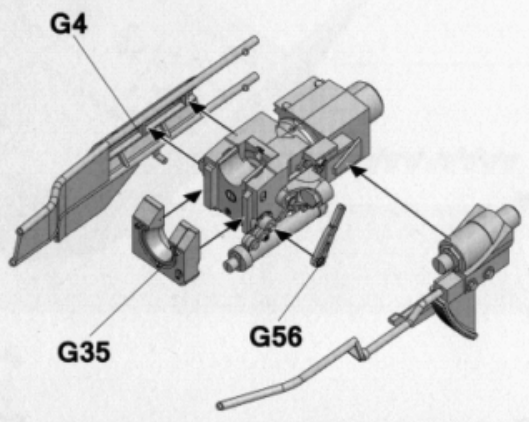
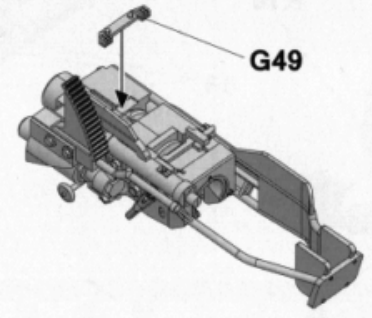
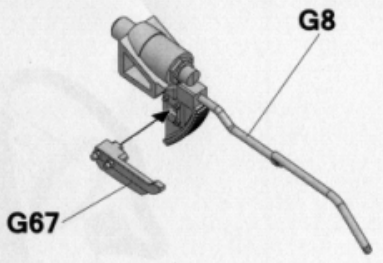
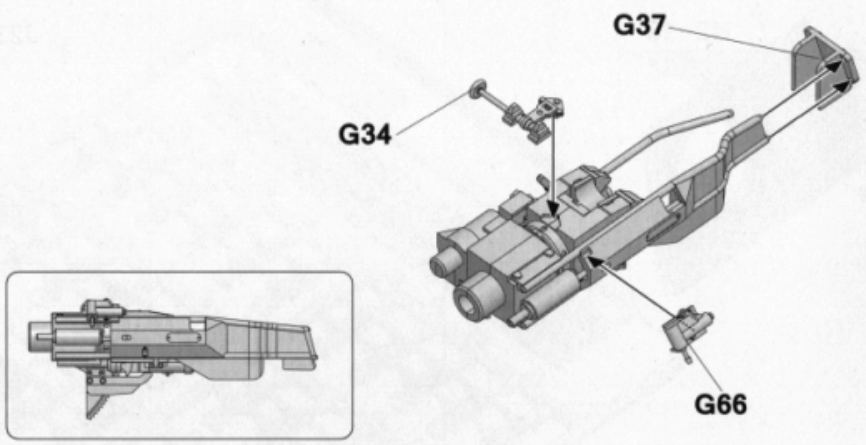
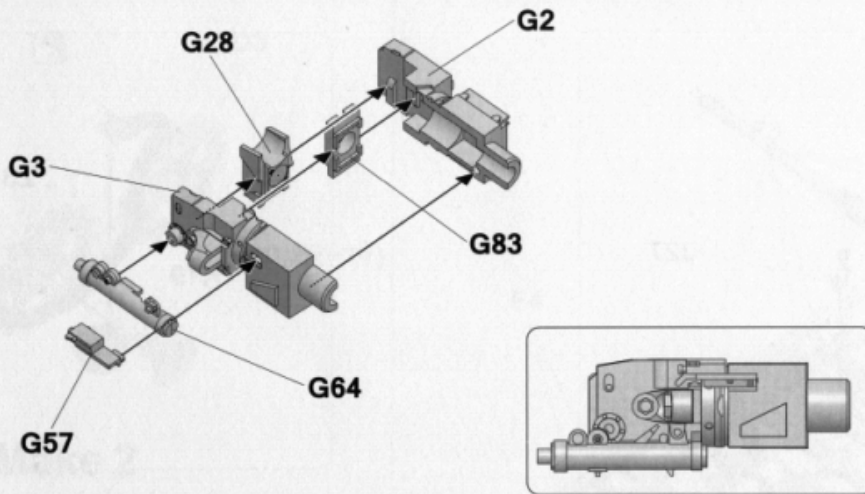

# 50-1

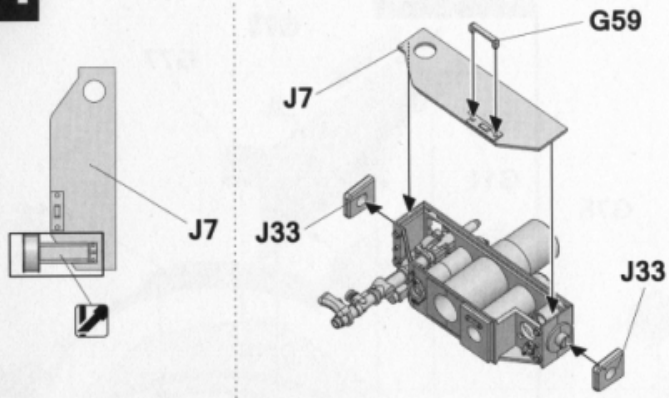

# 50-2

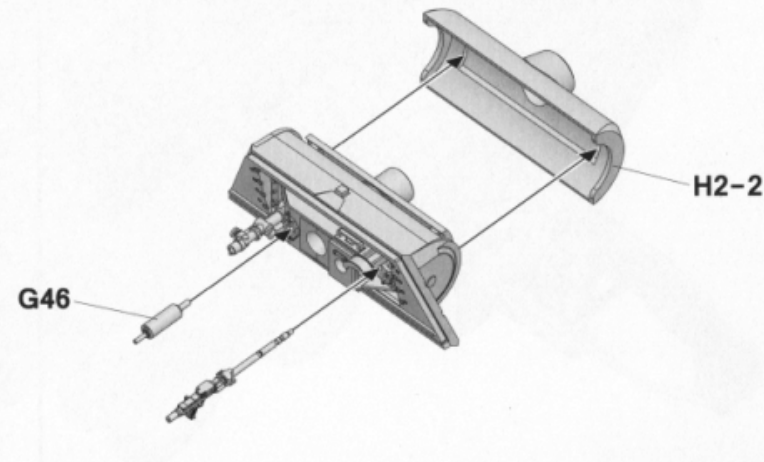
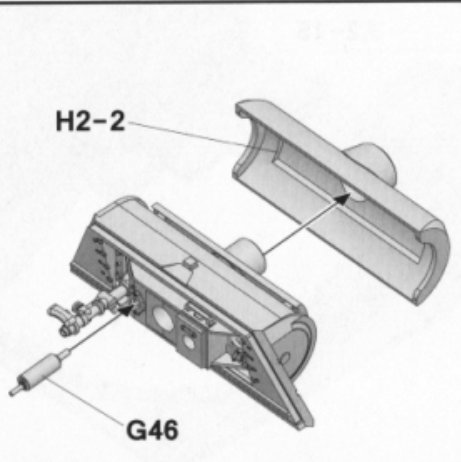
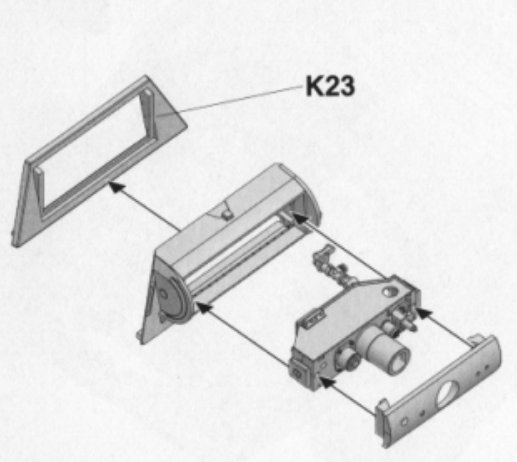
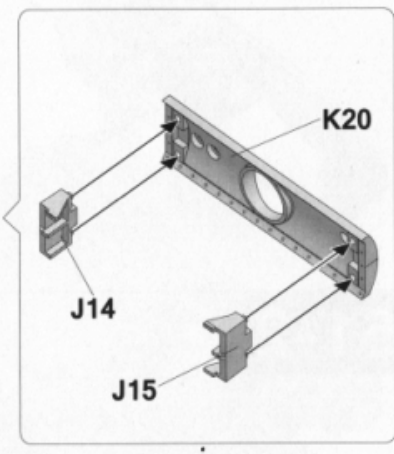
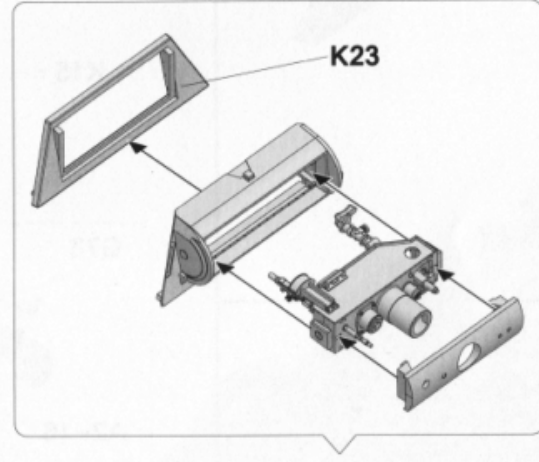
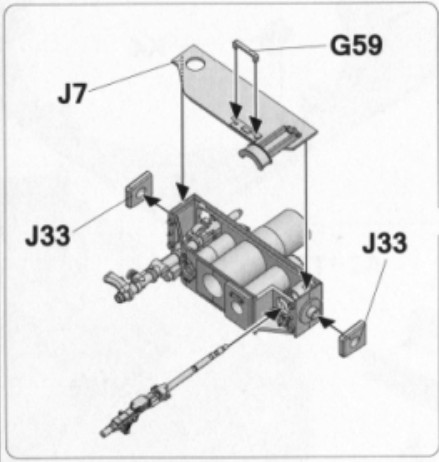
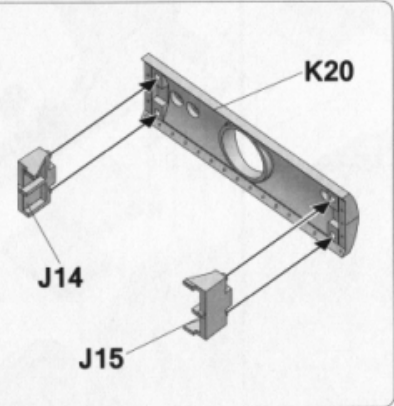
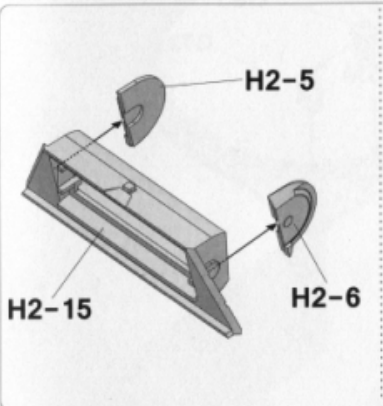
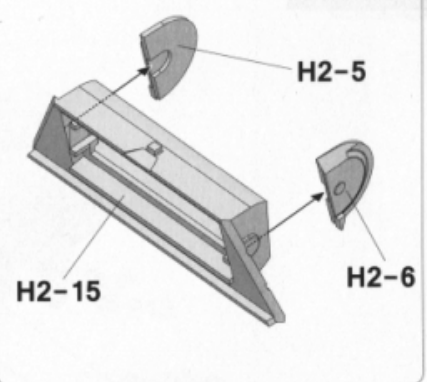
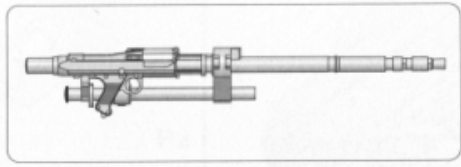
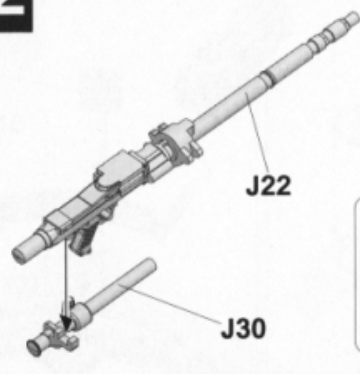



51-1

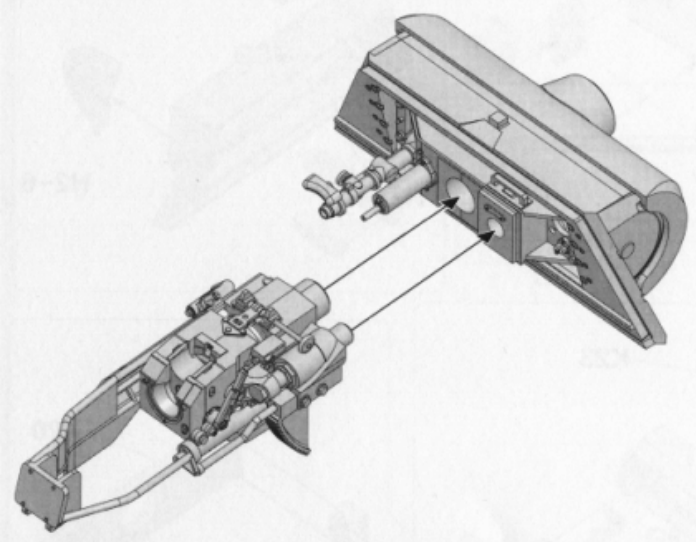

51-2

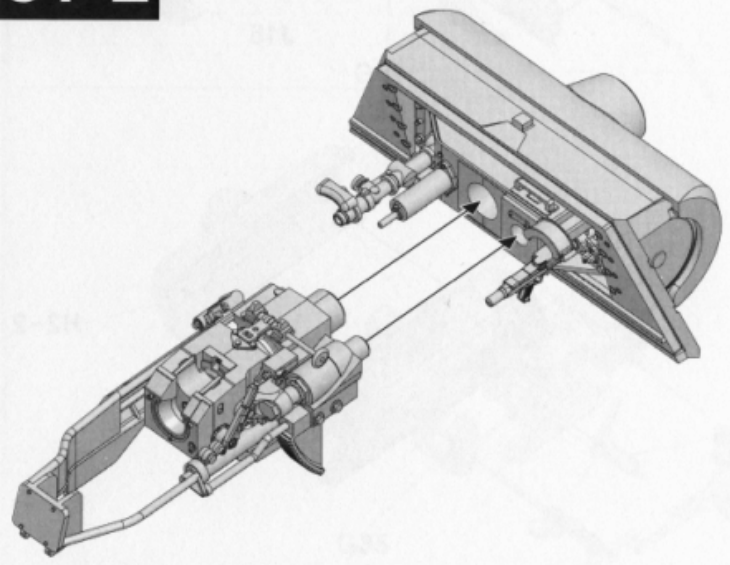

52-1

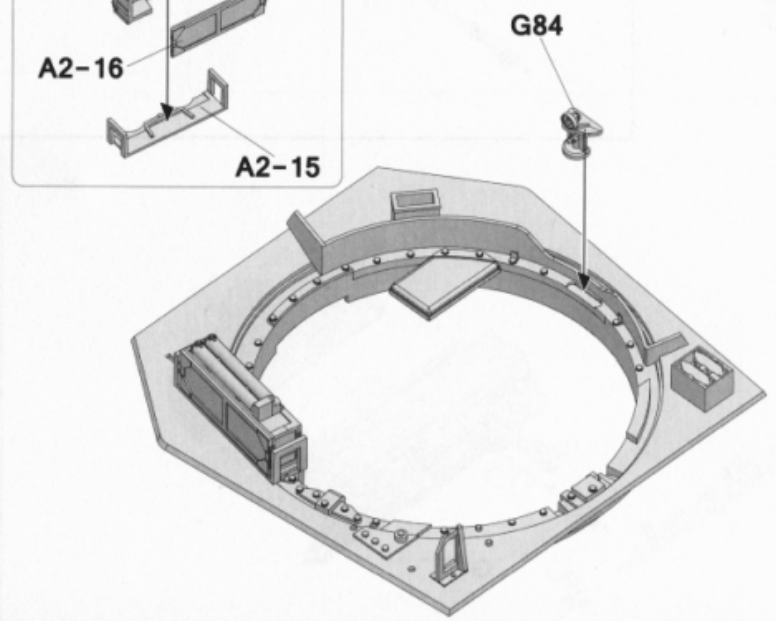
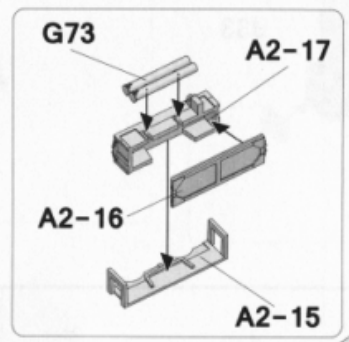
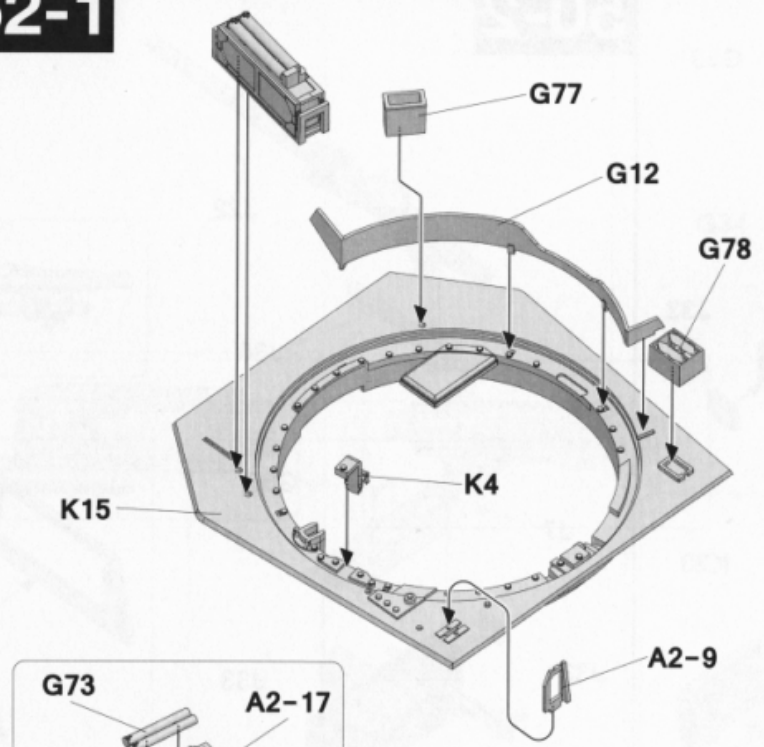

52-2

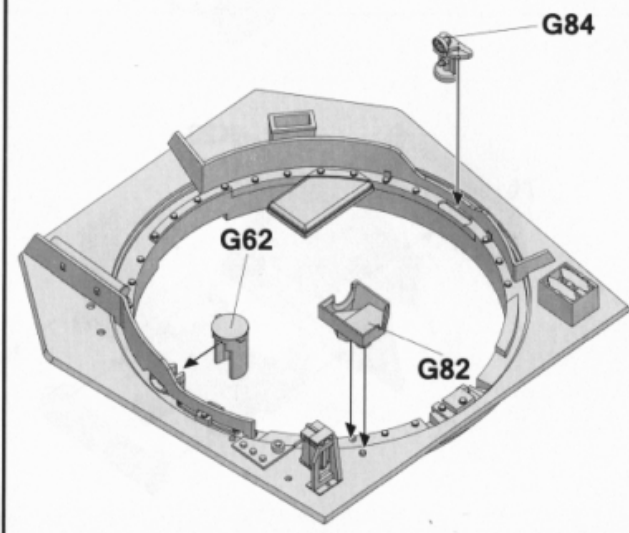
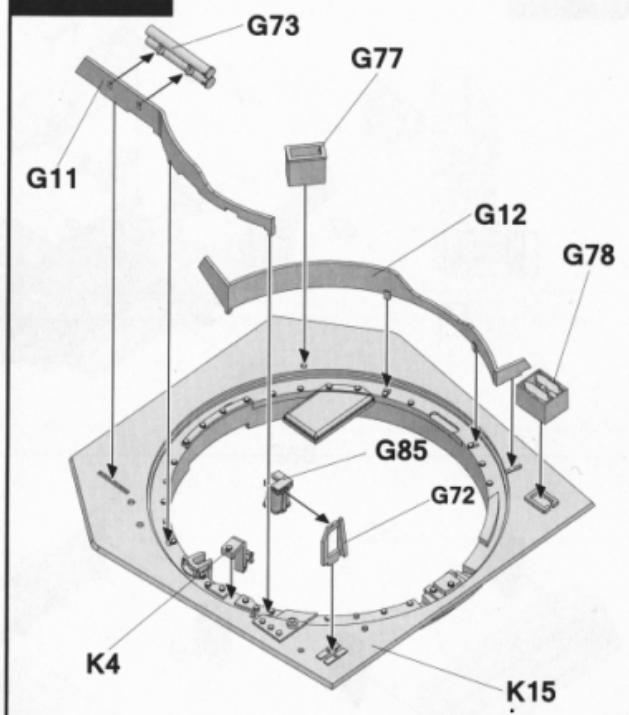

# 53

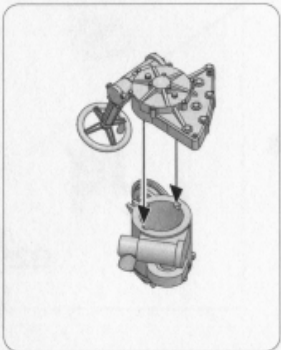
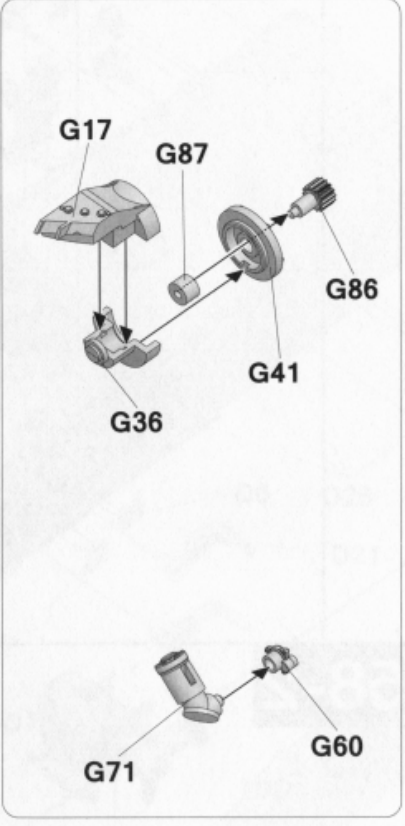
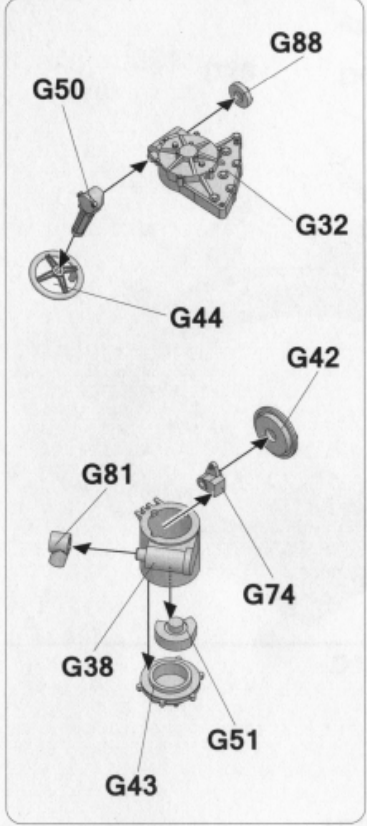

# 54-1

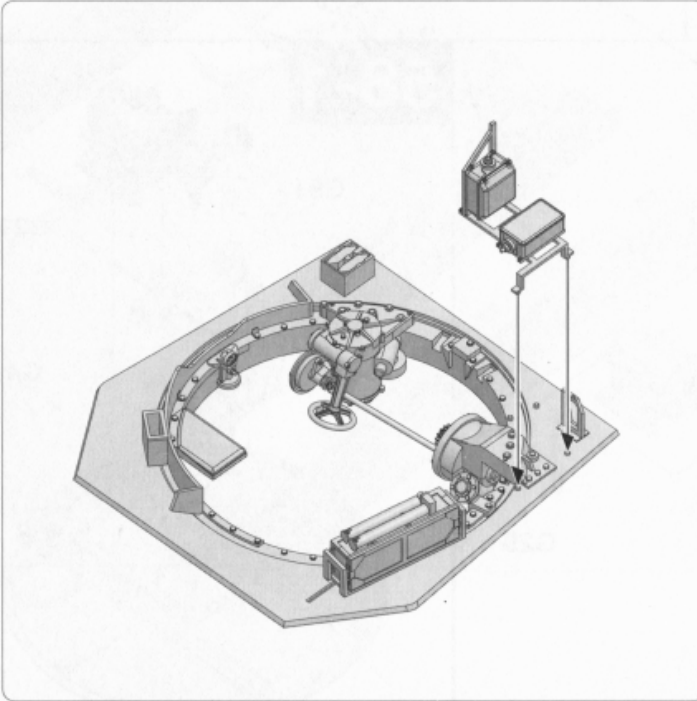
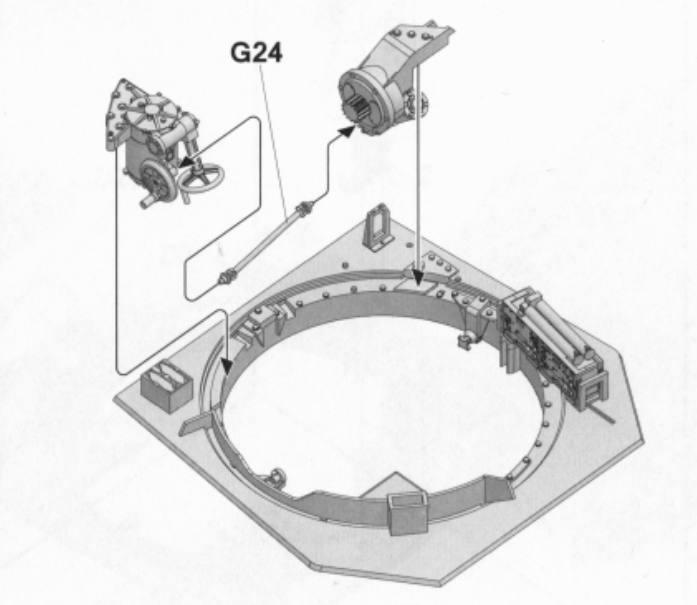

# 54-2

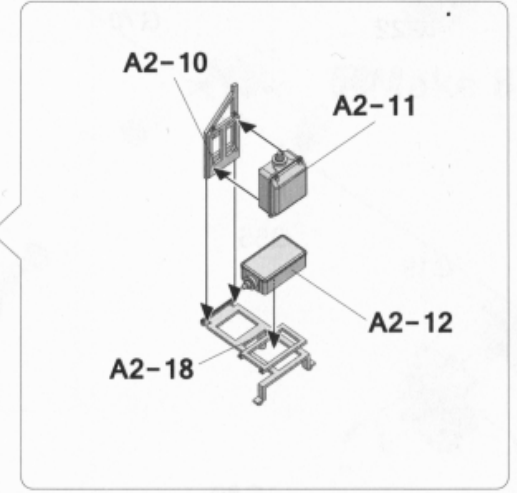
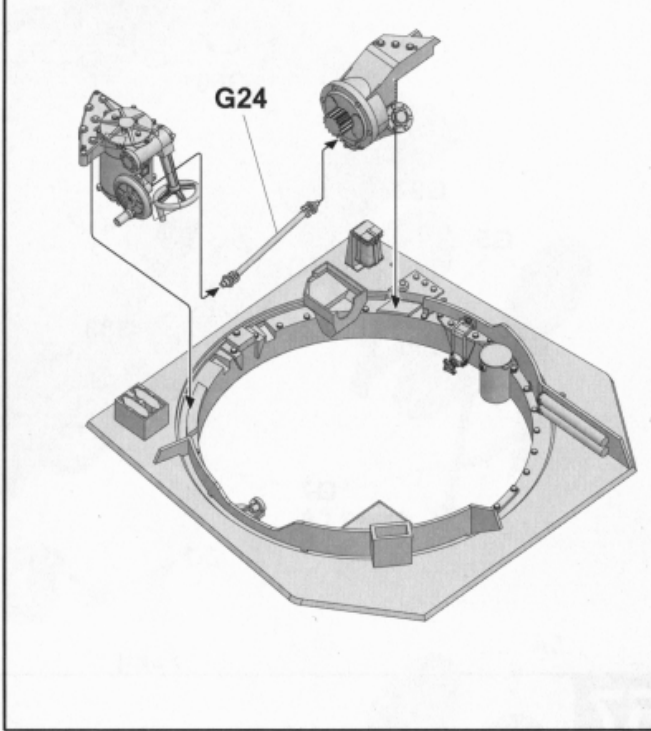



55

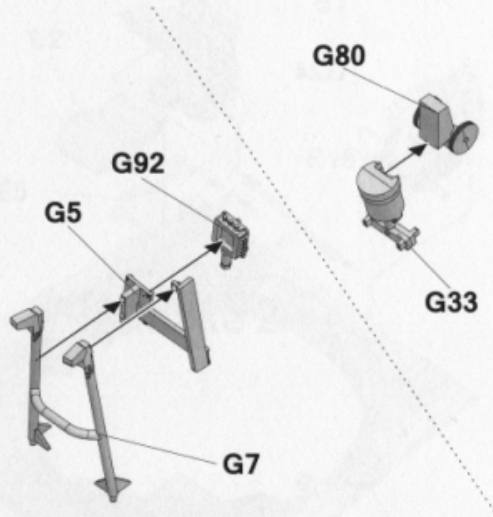

56-1

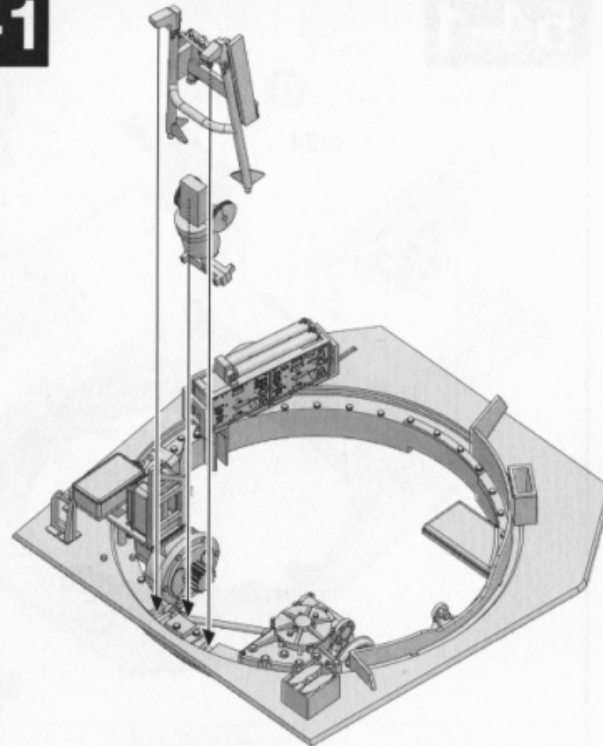

56-2

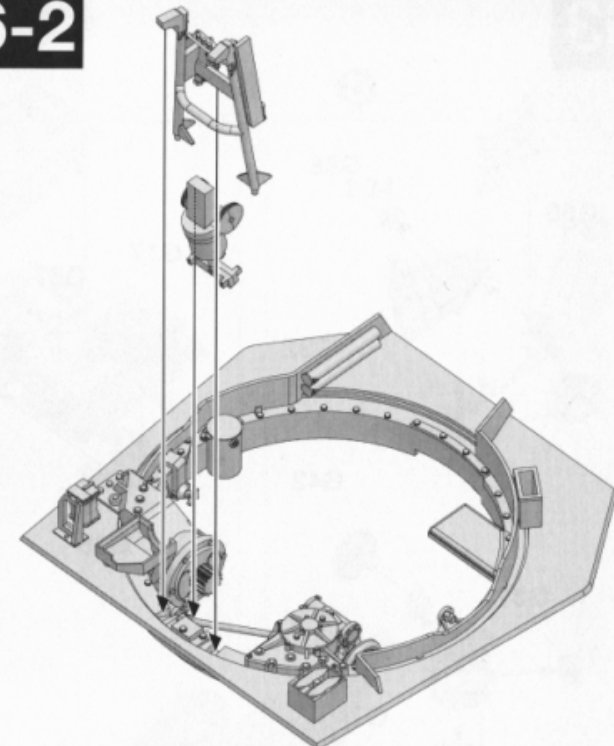

57

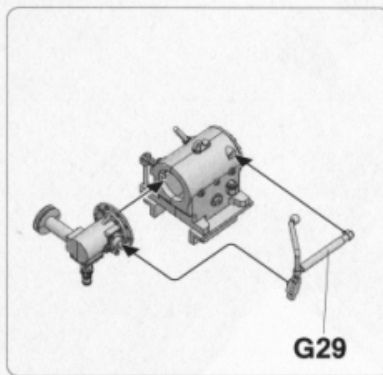
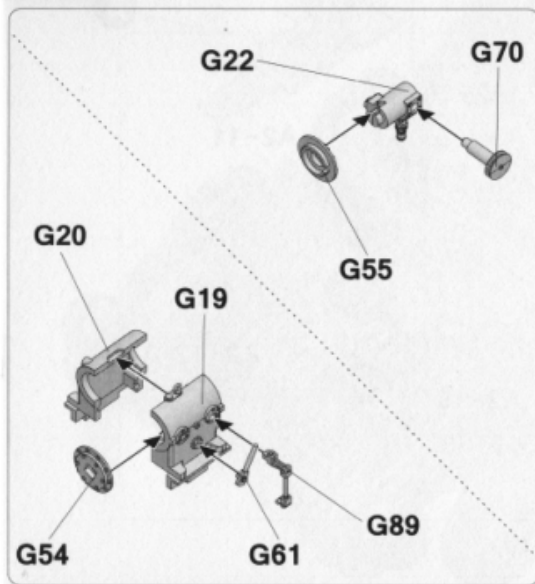

58-1

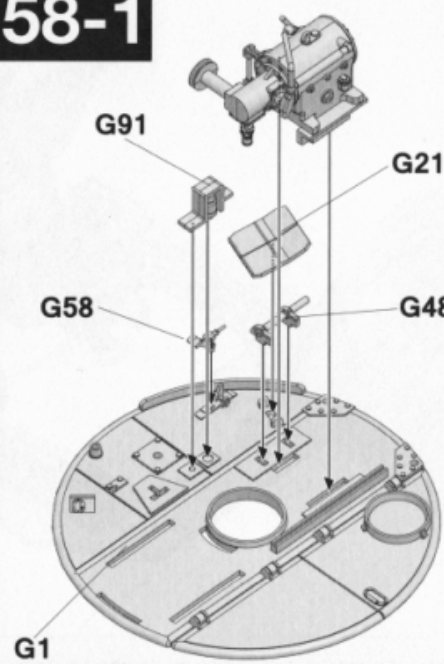

58-2

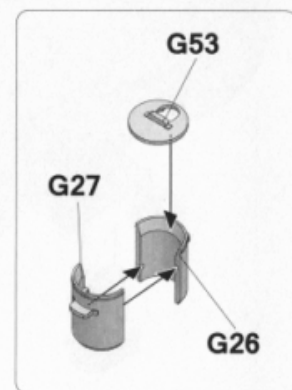
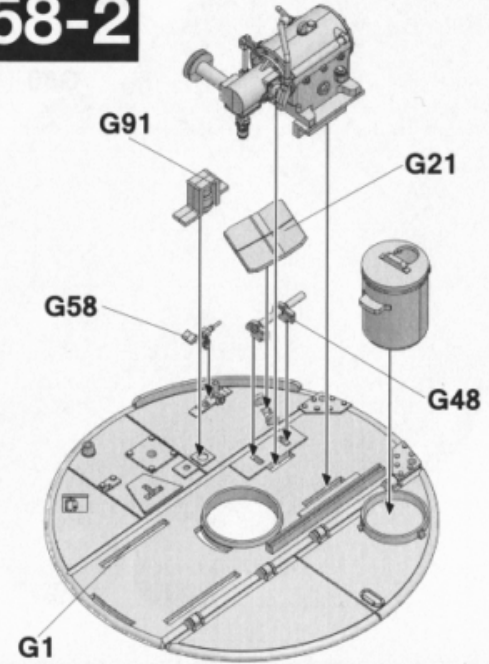



59

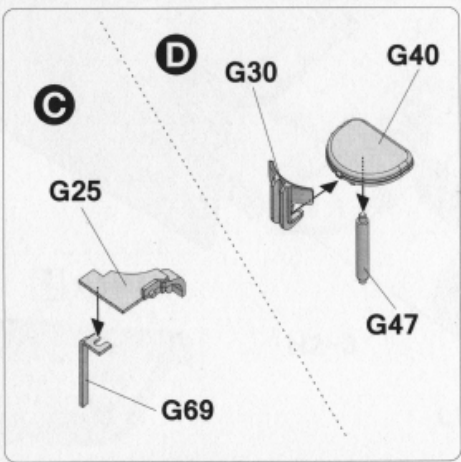
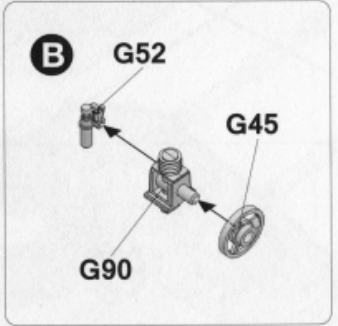
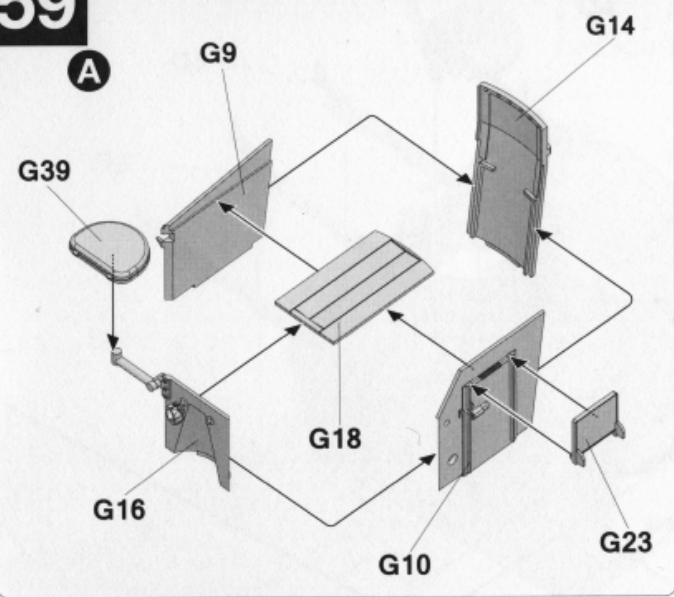

60-1

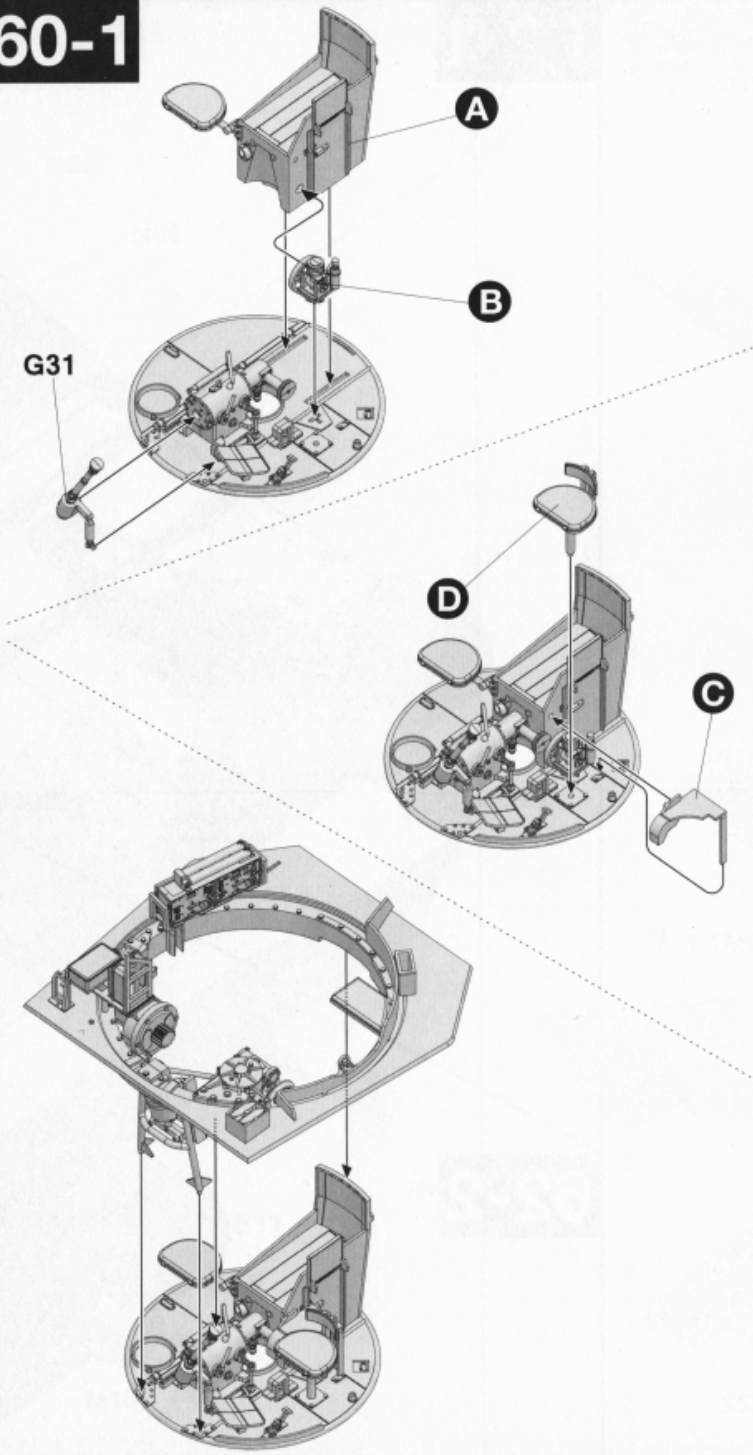

60-2

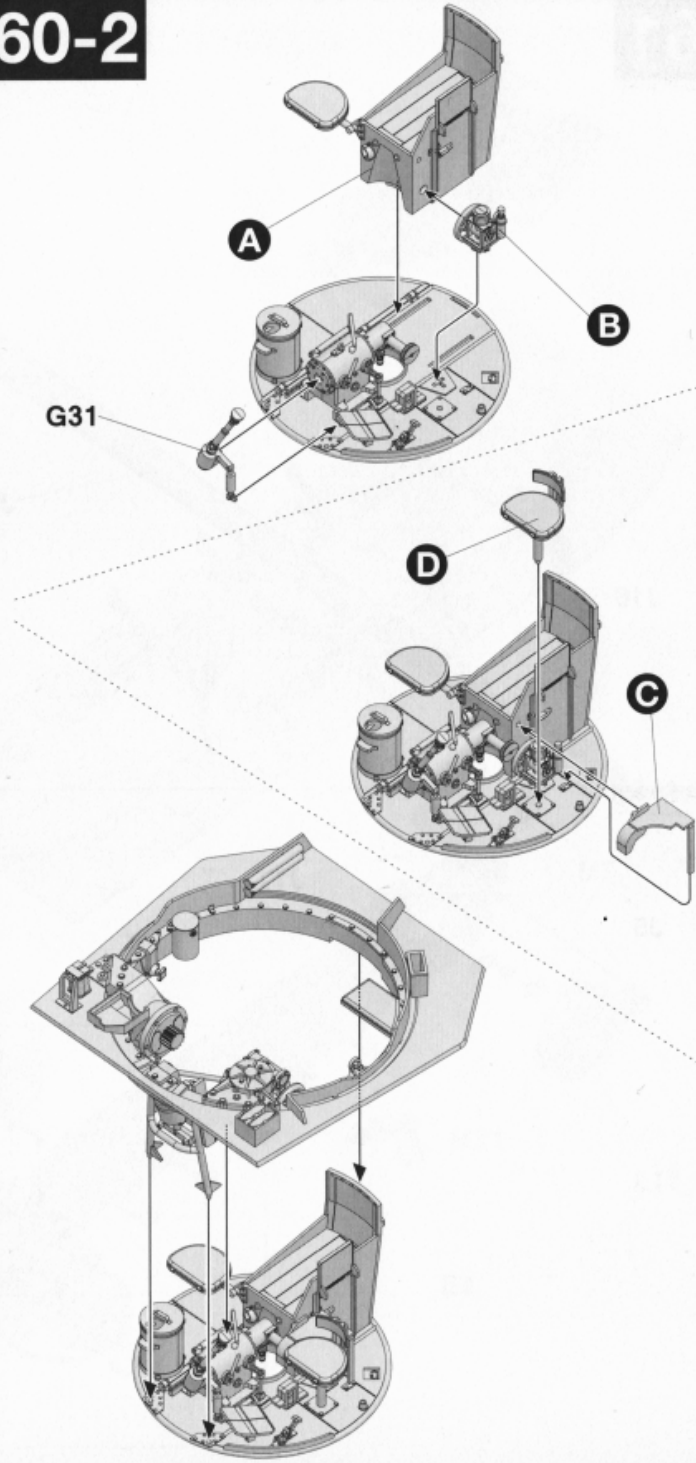



61

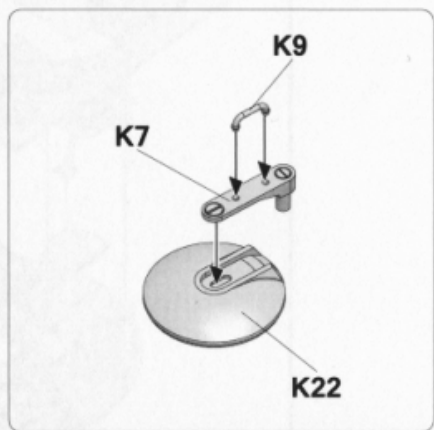
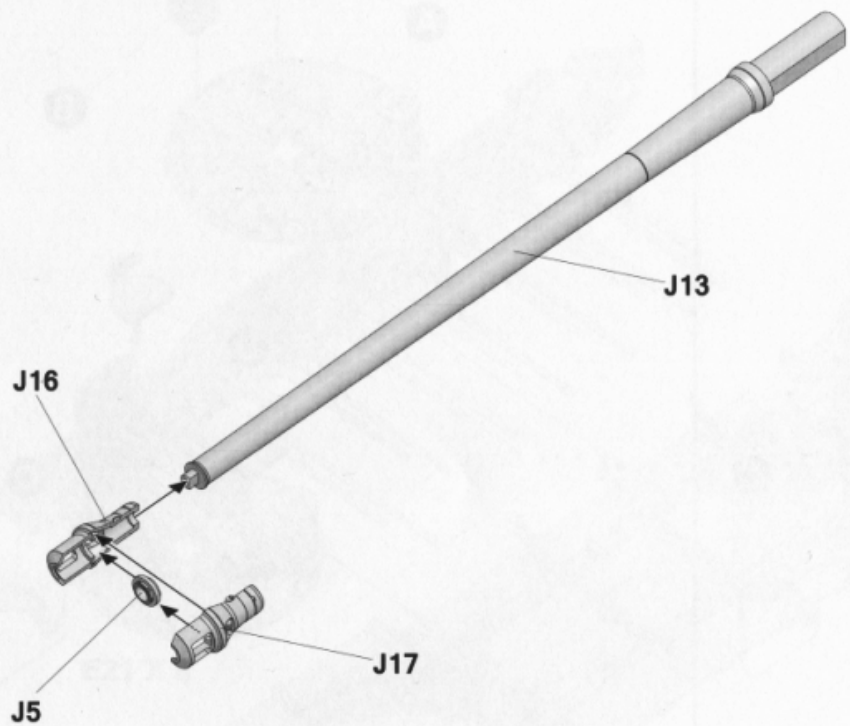

62-1

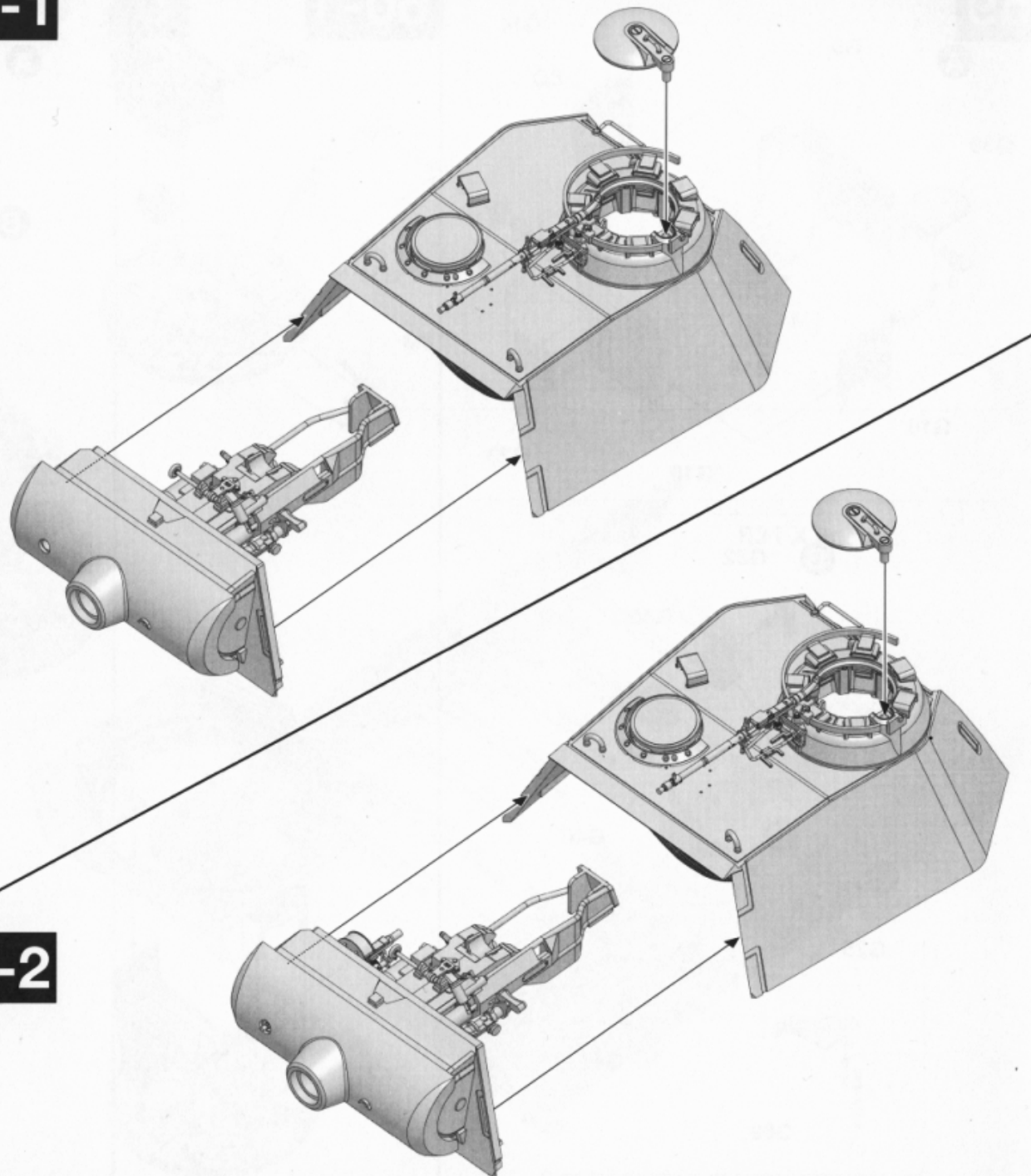

# 63-1

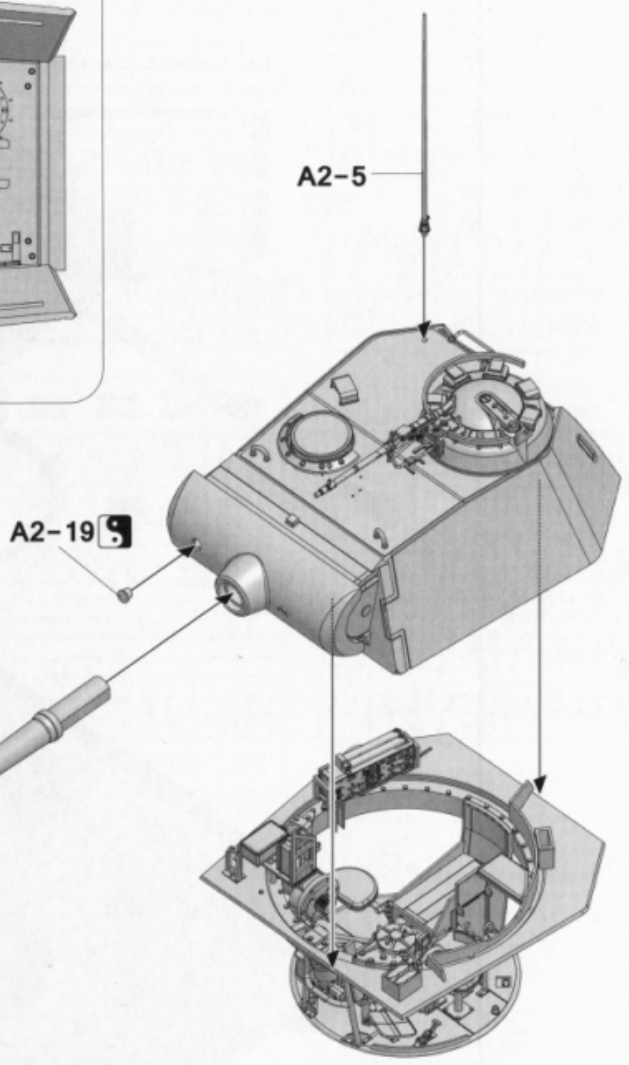
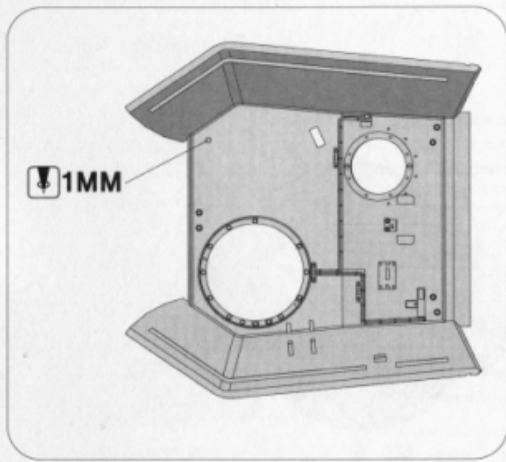

# 63-2

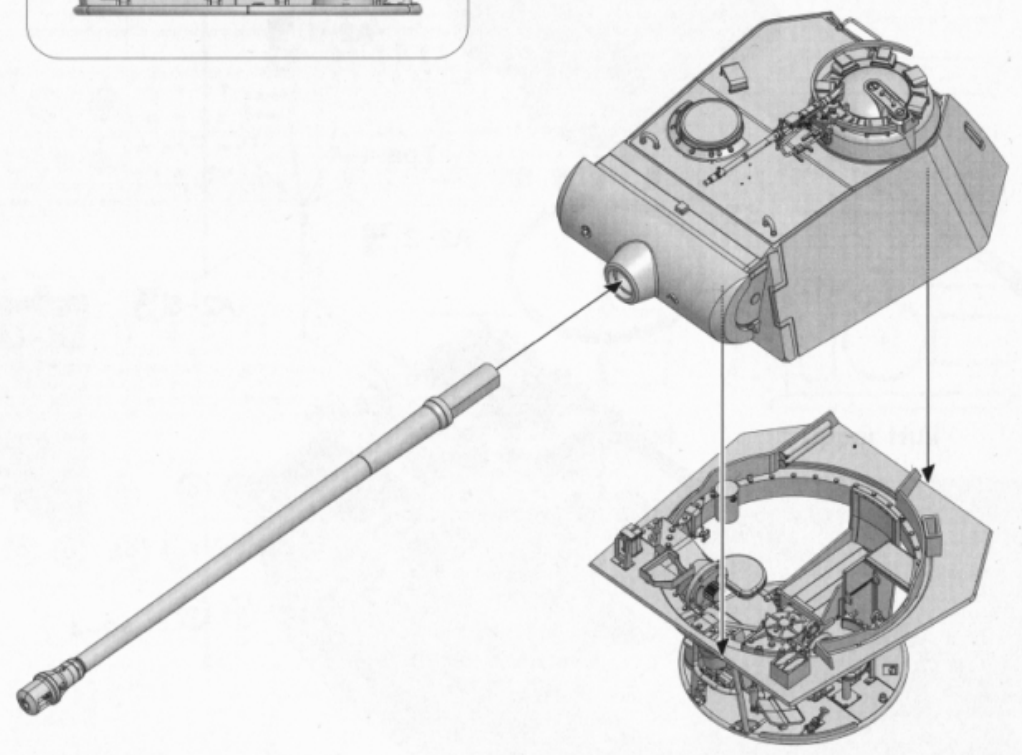
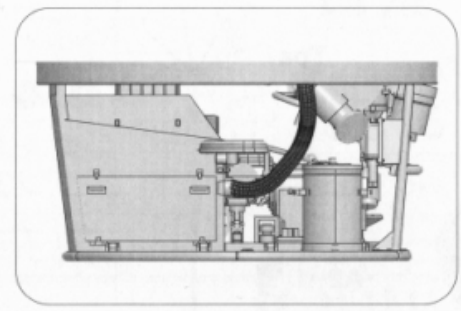



4-1

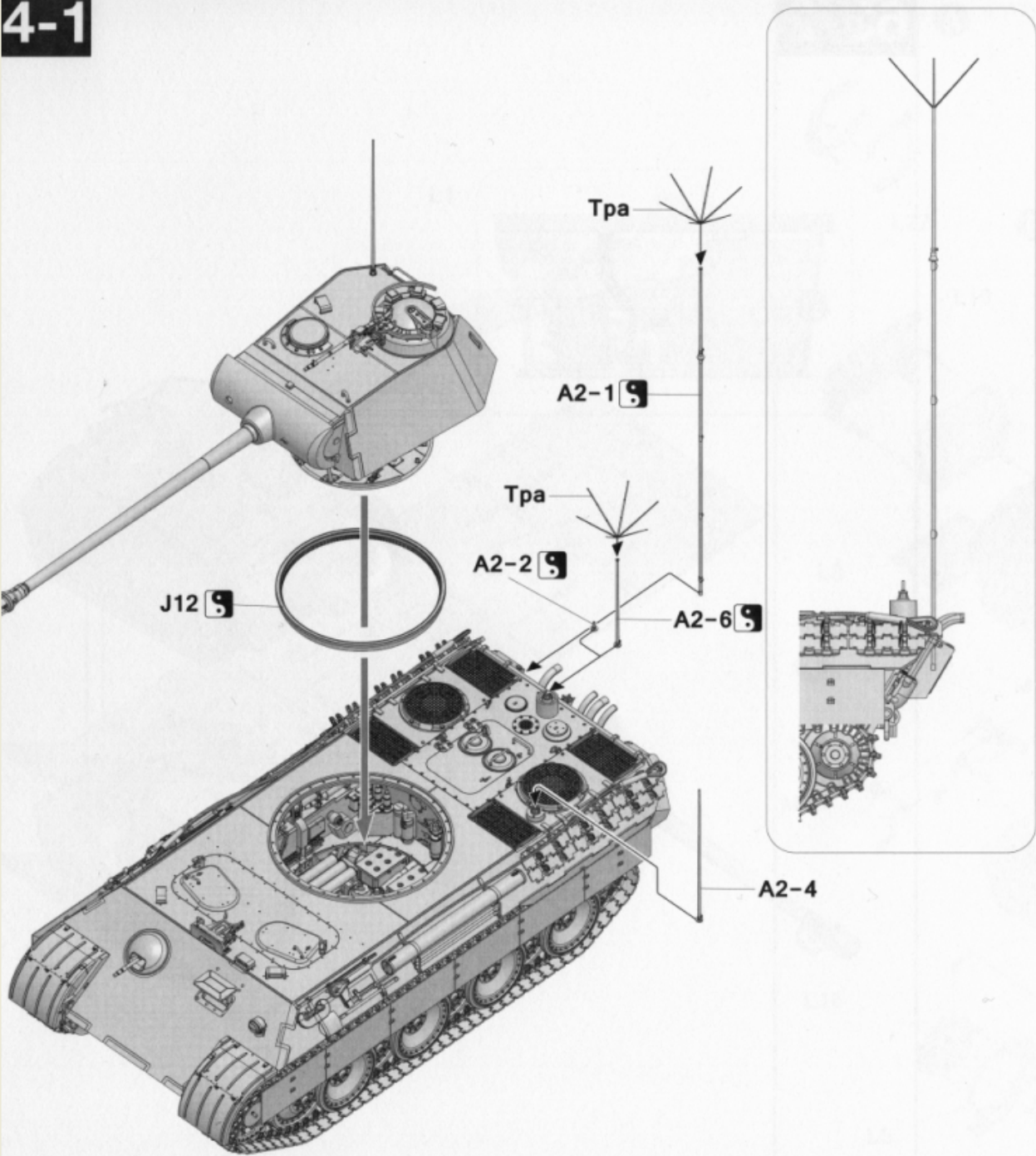

64-2

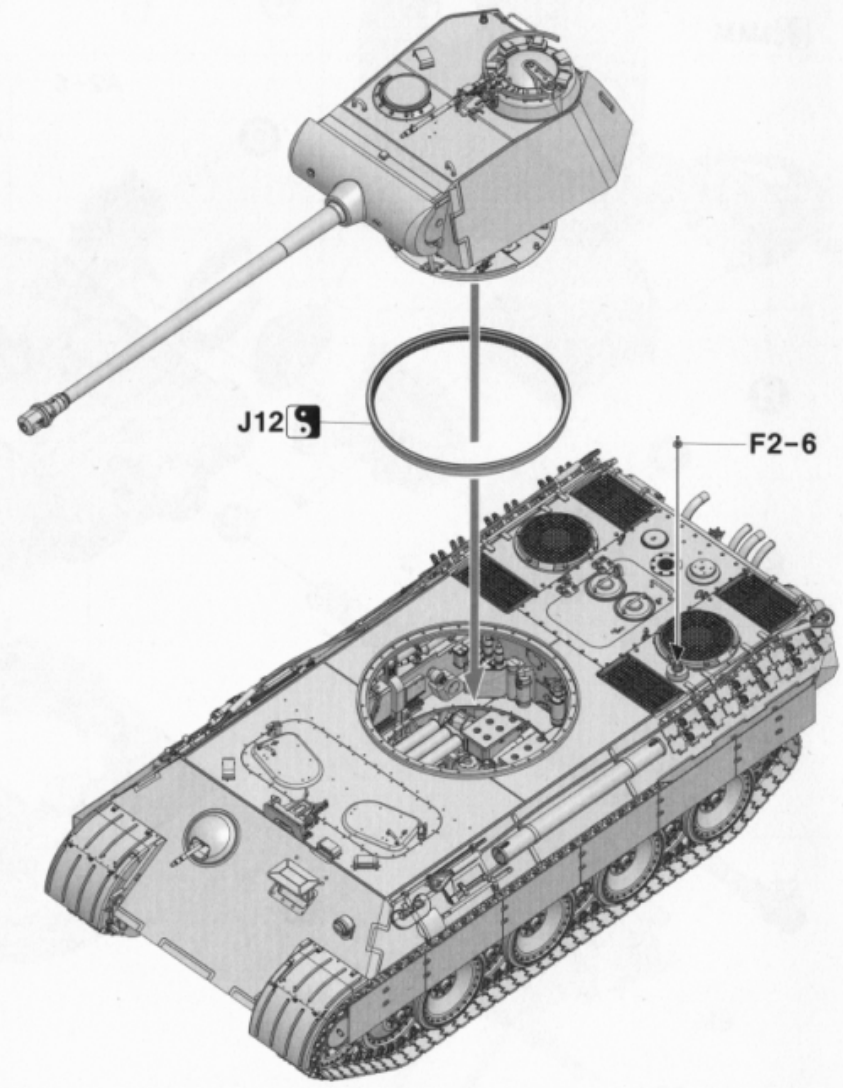

2018/2100

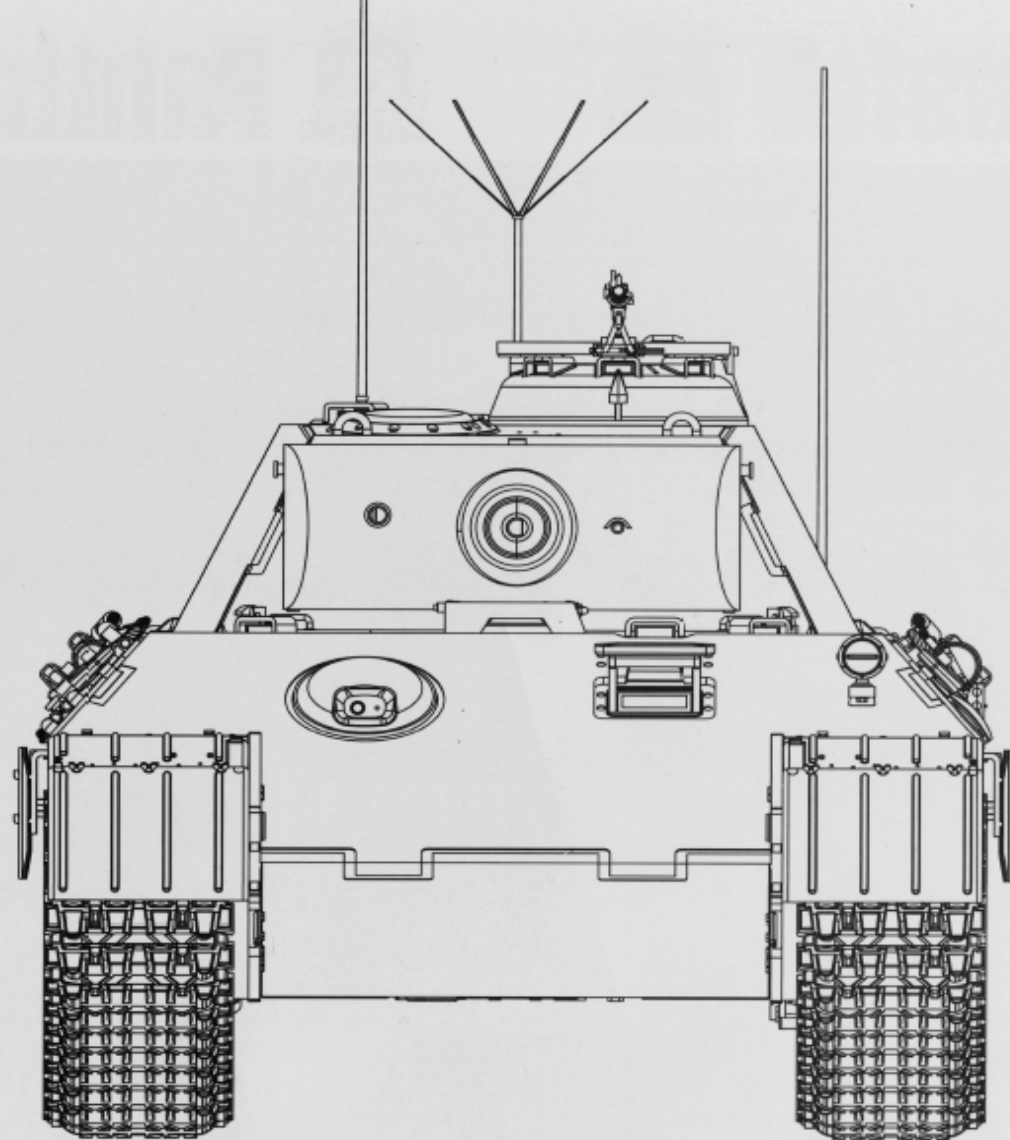

You can find TAKOM on Facebook.com



## Painting and Marking Guide

**TAKOM** Ref: 2100

WWII German medium Tank Sd.Kfz.171/267  
 Panther A mid-late production w/Zimmerit  
 and full interior 2 in 1  
 Panther A, 3./SS-Panzer Regiment 1, France 1944

- |                                 |                                     |                              |  |
|---------------------------------|-------------------------------------|------------------------------|--|
| <b>A.MIG 033</b> Rubber & Tires | <b>A.MIG 035</b> Dark Tracks        | <b>A.MIG 036</b> Old Wood    | <b>A.MIG 038</b> Old Wood                |
| <b>A.MIG 040</b> Medium Rust    | <b>A.MIG 045</b> Gun Metal          | <b>A.MIG 093</b> Crystal Red | <b>A.MIG 096</b> Crystal Periscope Green |
| <b>A.MIG 002</b> Olivgrün Opt.2 | <b>A.MIG 010</b> Dunkelgelb Mid war | <b>A.MIG 015</b> Schokobraun |  |

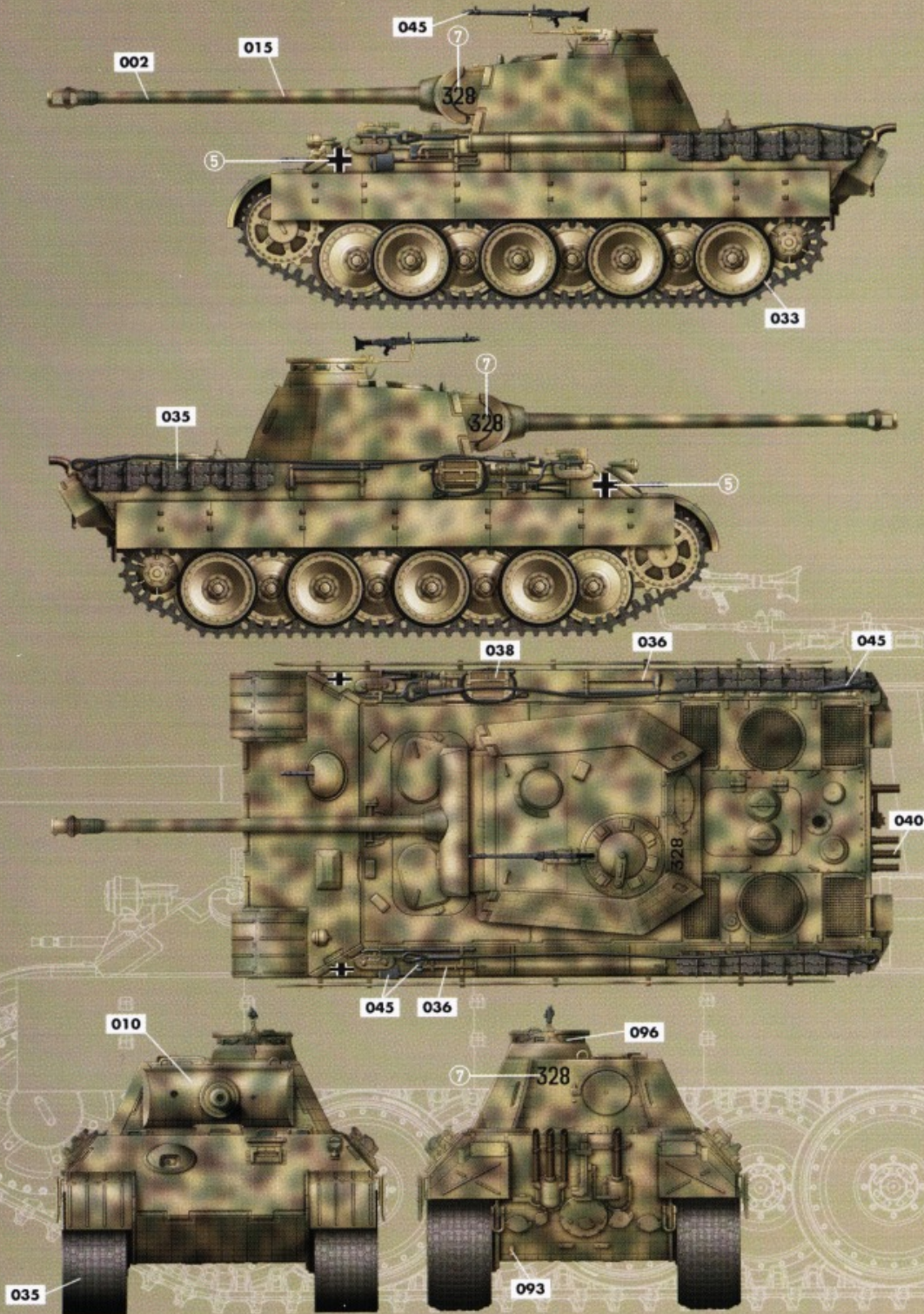

### WEATHERING STEPS WITH AMMO PRODUCTS

- |   |   |  |   |
|---|---|--|---|
| <p><b>1 GENERAL WASH</b><br/>                 A.MIG-1000 Brown Wash for German Yellow</p> <p><b>2 FILTER</b><br/>                 A.MIG-1510 Tone for 3 tone camo</p> | <p><b>3 STREAKING</b><br/>                 A.MIG-1203 Streaking Grime</p> <p><b>4 RUST</b><br/>                 A.MIG-3510 Rust</p> | <p><b>5 TRACK WASH</b><br/>                 A.MIG-1002 Tracks Wash</p> <p><b>6 DUST</b><br/>                 A.MIG-3013 Rubbel</p> | <p><b>7 MUD</b><br/>                 A.MIG-3007 Dark Earth<br/>                 A.MIG-1752 Loose Ground</p> |
|---|---|--|---|



## Painting and Marking Guide

**TAKOM** Ref: 2100

WWII German medium Tank Sd.Kfz.171/267  
Panther A mid-late production w/Zimmerit  
and full interior 2 in 1

Panther A, 3 Kompanie, Pz. Reg. Grossdeutschland,  
France June 1944

<b>A.MIG 033</b> Rubber & Tires	<b>A.MIG 035</b> Dark Tracks	<b>A.MIG 036</b> Old Wood	<b>A.MIG 038</b> Old Wood
<b>A.MIG 040</b> Medium Rust	<b>A.MIG 045</b> Gun Metal	<b>A.MIG 093</b> Crystal Red	<b>A.MIG 096</b> Crystal Periscope Green
<b>A.MIG 002</b> Olivgrün Opt.2	<b>A.MIG 010</b> Dunkelgelb Mid war	<b>A.MIG 015</b> Schakobraun	

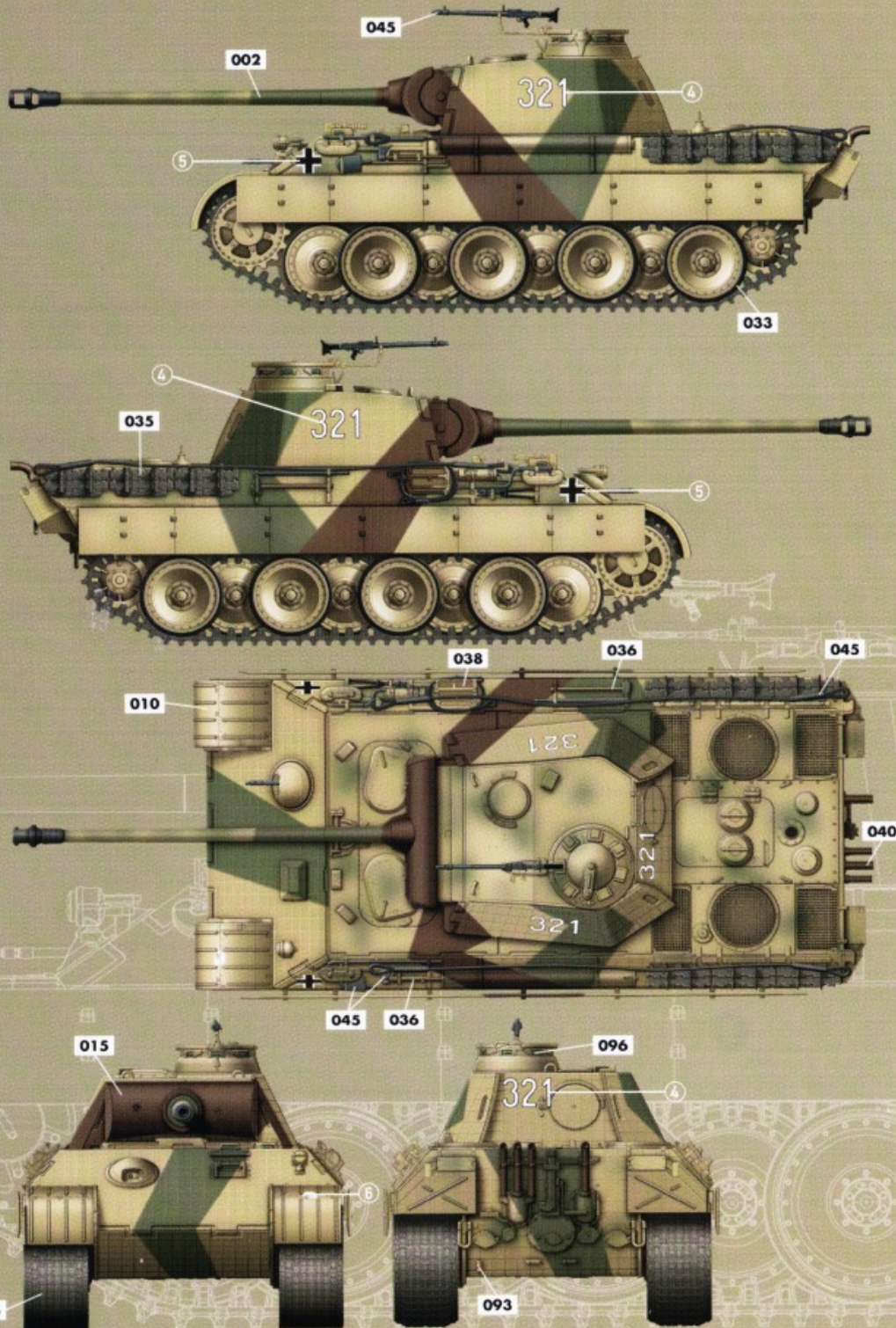

### WEATHERING STEPS WITH AMMO PRODUCTS

#### 1 GENERAL WASH

A.MIG-1000 Brown Wash for German Yellow

#### 2 FILTER

A.MIG-1510 Tone for 3 tone camo

#### 3 STREAKING

A.MIG-1203 Streaking Grime

#### 4 RUST

A.MIG-3510 Rust

#### 5 TRACK WASH

A.MIG-1002 Tracks Wash

#### 6 DUST

A.MIG-3013 Rubbel

#### 7 MUD

A.MIG-3007 Dark Earth  
A.MIG-1752 Loose Ground



## Painting and Marking Guide

**TAKOM** Ref: 2100

WWII German medium Tank Sd.Kfz.171/267  
Panther A mid-late production w/Zimmerit  
and full interior 2 in 1

Panther A, Stab I Abteilung SS Pz Reg 2, France 1944

<b>A.MIG 033</b> Rubber & Tires	<b>A.MIG 035</b> Dark Tracks	<b>A.MIG 036</b> Old Wood	<b>A.MIG 038</b> Old Wood
<b>A.MIG 040</b> Medium Rust	<b>A.MIG 045</b> Gun Metal	<b>A.MIG 093</b> Crystal Red	<b>A.MIG 096</b> Crystal Periscope Green
<b>A.MIG 002</b> Olivgrün Opt.2	<b>A.MIG 010</b> Dunkelgelb Mid war	<b>A.MIG 015</b> Schokobraun	

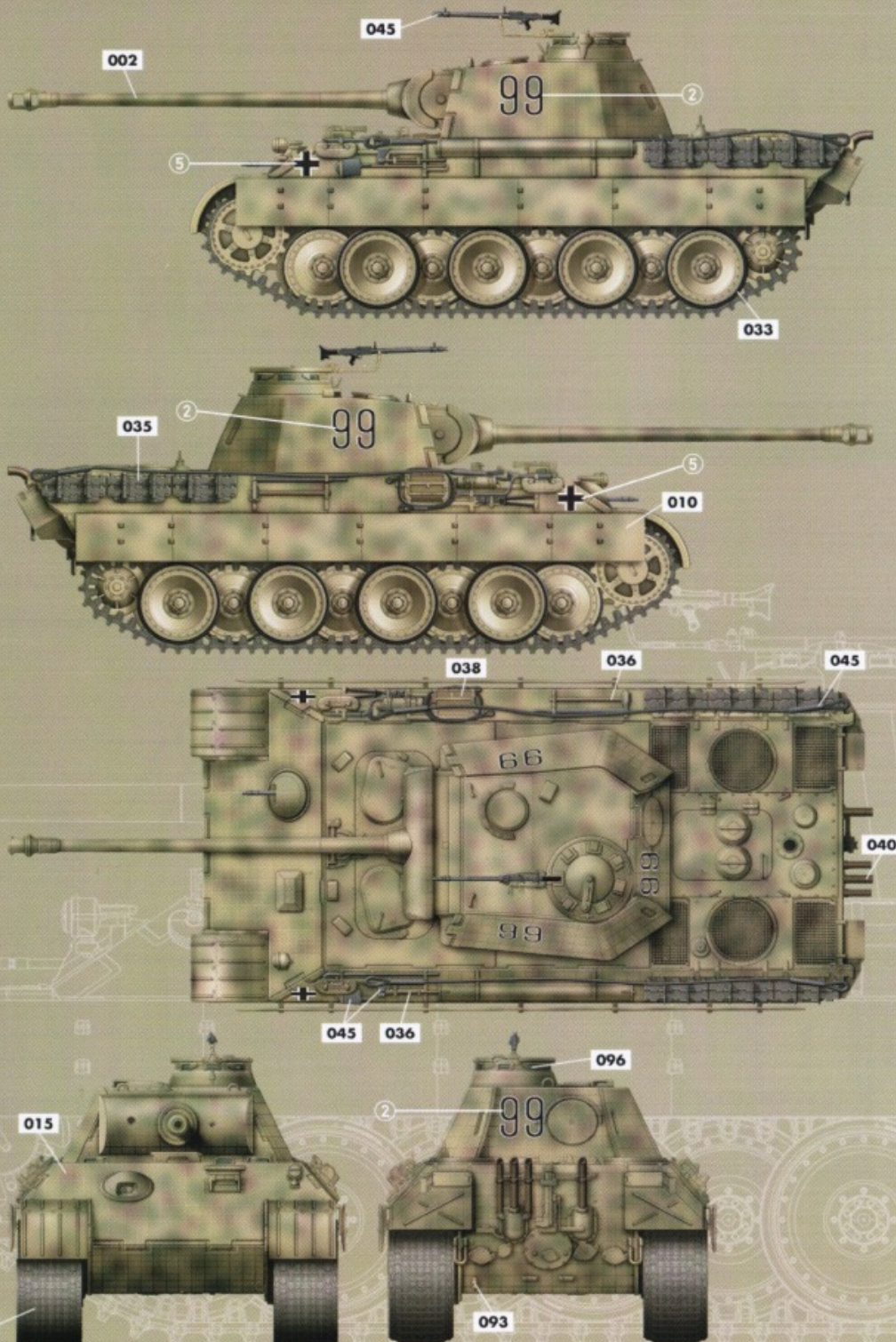

### WEATHERING STEPS WITH AMMO PRODUCTS

#### 1 GENERAL WASH

A.MIG-1000 Brown Wash for German Yellow

#### 2 FILTER

A.MIG-1510 Tone for 3 tone camo

#### 3 STREAKING

A.MIG-1203 Streaking Grime

#### 4 RUST

A.MIG-3510 Rust

#### 5 TRACK WASH

A.MIG-1002 Tracks Wash

#### 6 DUST

A.MIG-3013 Rubbel

#### 7 MUD

A.MIG-3007 Dark Earth  
A.MIG-1752 Loose Ground



## Painting and Marking Guide

**TAKOM** Ref: 2100

WWII German medium Tank Sd.Kfz.171/267  
Panther A mid-late production w/Zimmerit  
and full interior 2 in 1

Panther A, 4 kompanie SS Pz Reg 2,  
Mont Ormel, Italy 1944

**A.MIG 033** Rubber & Tires

**A.MIG 035** Dark Tracks

**A.MIG 036** Old Wood

**A.MIG 038** Old Wood

**A.MIG 040** Medium Rust

**A.MIG 045** Gun Metal

**A.MIG 093** Crystal Red

**A.MIG 096** Crystal  
Periscope Green

**A.MIG 002** Olivgrün Opt.2

**A.MIG 010** Dunkelgelb  
Mid war

**A.MIG 015** Schakabraun



### WEATHERING STEPS WITH AMMO PRODUCTS

#### 1 GENERAL WASH

A.MIG-1000 Brown Wash for German Yellow

#### 2 FILTER

A.MIG-1510 Tone for 3 tone camo

#### 3 STREAKING

A.MIG-1203 Streaking Grime

#### 4 RUST

A.MIG-3510 Rust

#### 5 TRACK WASH

A.MIG-1002 Tracks Wash

#### 6 DUST

A.MIG-3013 Rubbel

#### 7 MUD

A.MIG-3007 Dark Earth  
A.MIG-1752 Loose Ground



## Painting and Marking Guide

**TAKOM** Ref: 2100

WWII German medium Tank Sd.Kfz.171/267  
Panther A mid-late production w/Zimmerit  
and full interior 2 in 1

Panzer Regiment Grossdeutschland,  
Jassy Romania April 1944

**A.MIG 033** Rubber & Tires

**A.MIG 035** Dark Tracks

**A.MIG 036** Old Wood

**A.MIG 038** Old Wood

**A.MIG 040** Medium Rust

**A.MIG 045** Gun Metal

**A.MIG 093** Crystal Red

**A.MIG 096** Crystal  
Periscope Green

**A.MIG 002** Olivgrün Opt.2

**A.MIG 010** Dunkelgelb  
Mid war

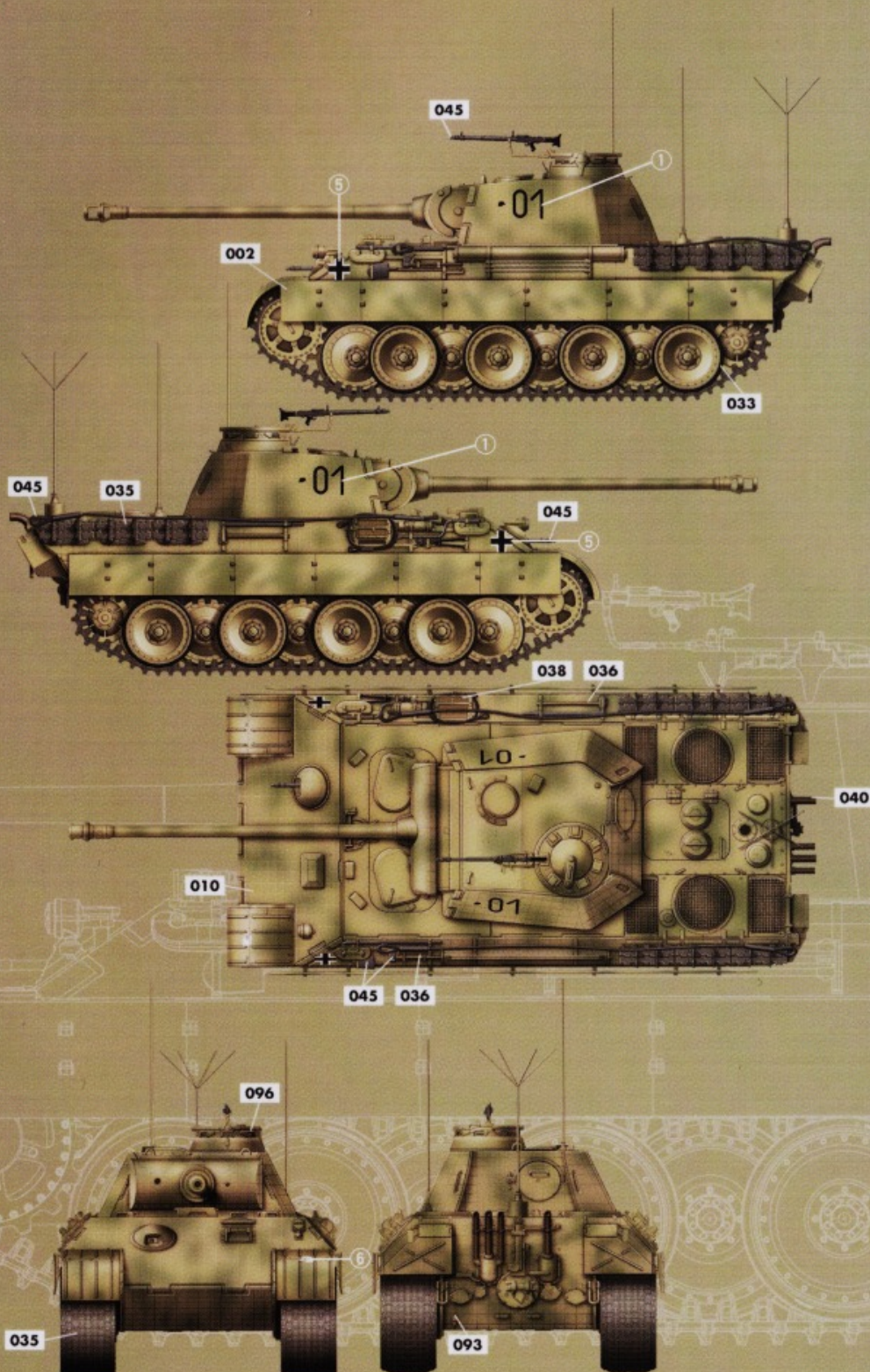

### WEATHERING STEPS WITH AMMO PRODUCTS

**1 GENERAL WASH**

A.MIG-1000 Brown Wash for German Yellow

**2 FILTER**

A.MIG-1510 Tone for 3 tone camo

**3 STREAKING**

A.MIG-1203 Streaking Grime

**4 RUST**

A.MIG-3510 Rust

**5 TRACK WASH**

A.MIG-1002 Tracks Wash

**6 DUST**

A.MIG-3013 Rubbel

**7 MUD**

A.MIG-3007 Dark Earth  
A.MIG-1752 Loose Ground



# Interior Painting

Panther A family

Color info and profiles by



for #2097/2098/2099/2100

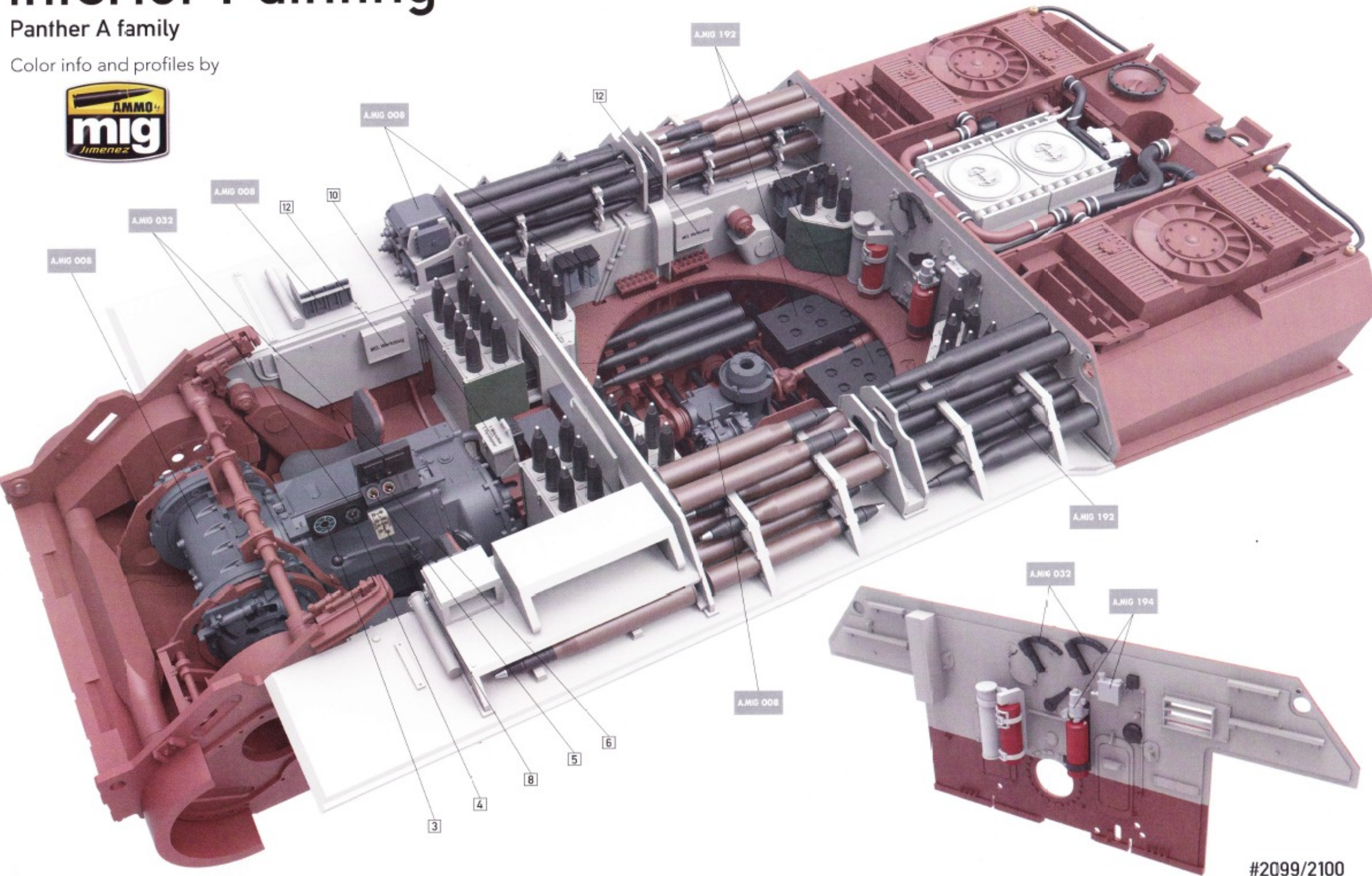

#2099/2100



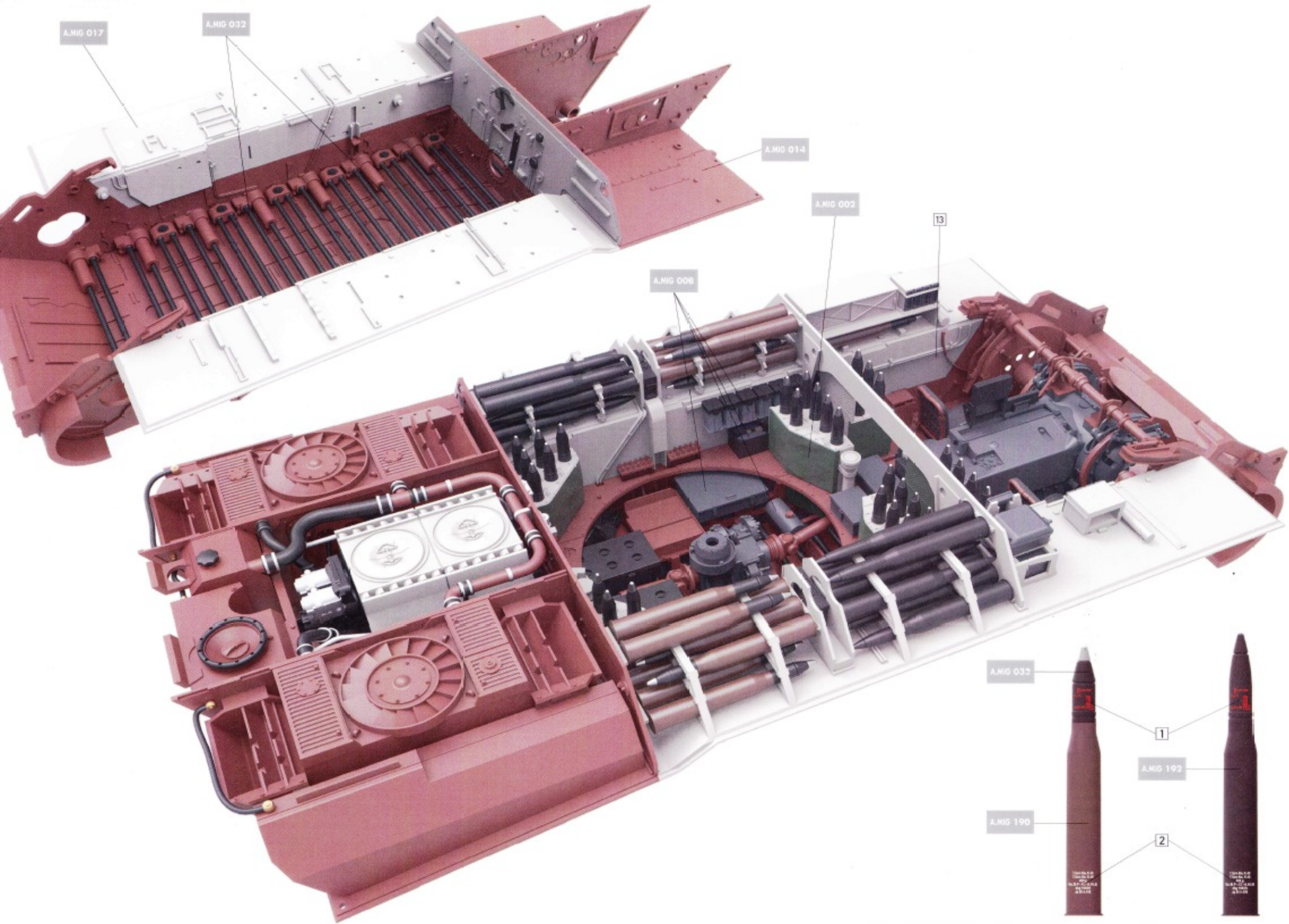



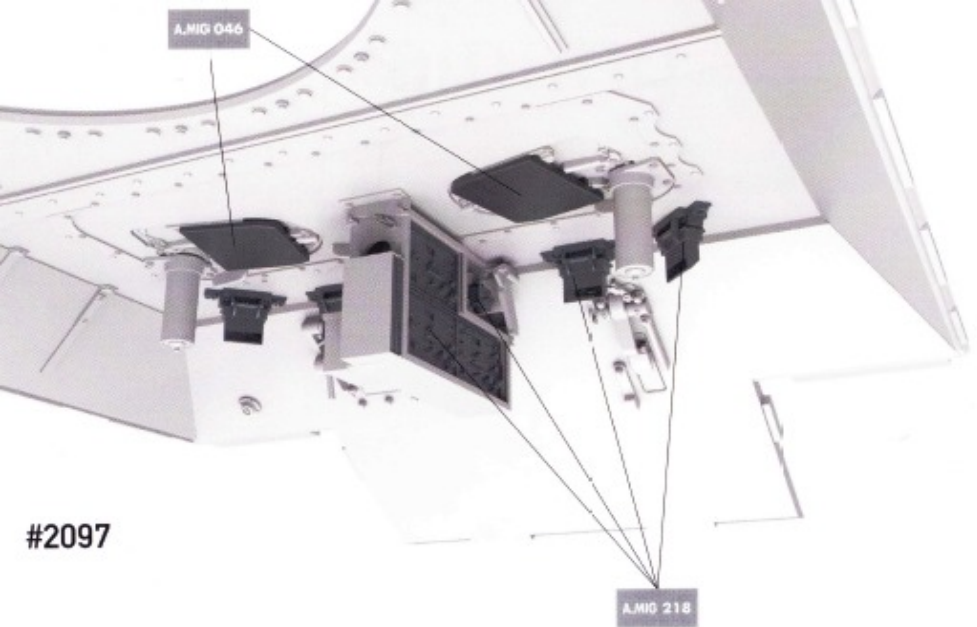

#2097

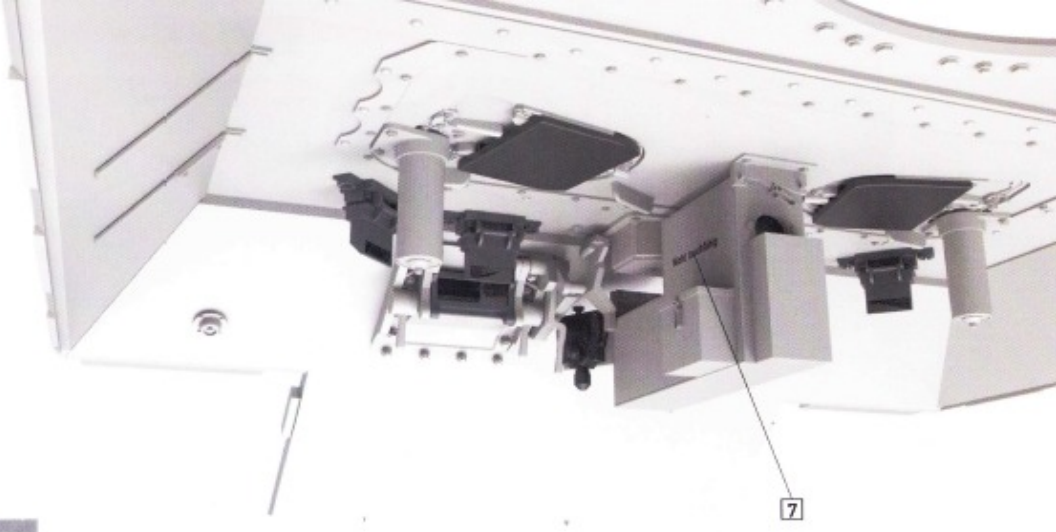

7

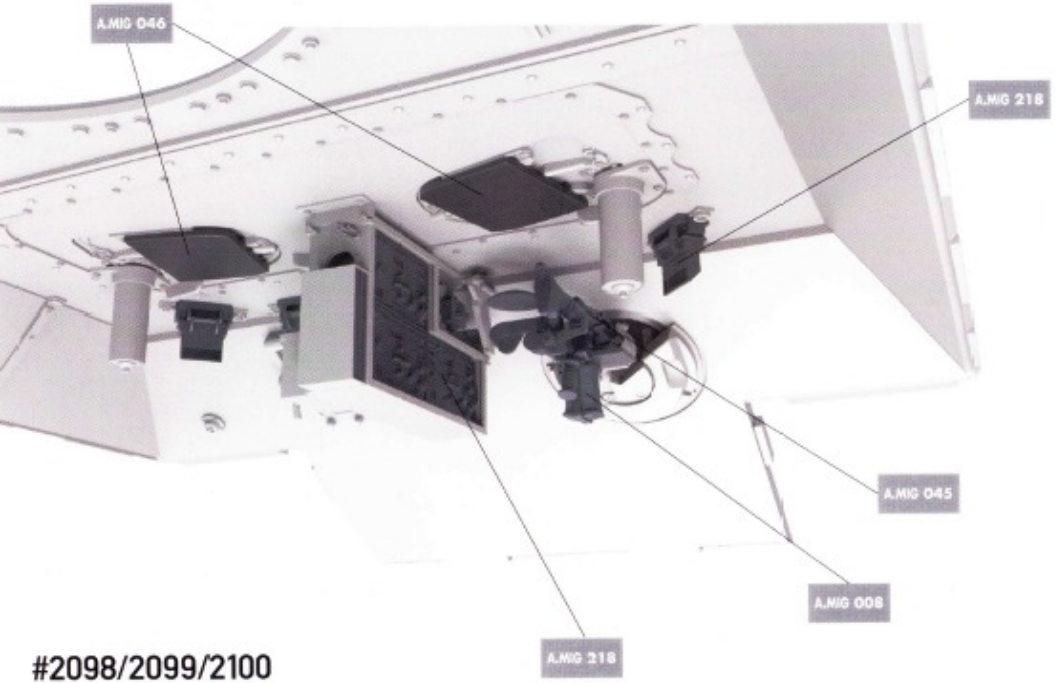

#2098/2099/2100

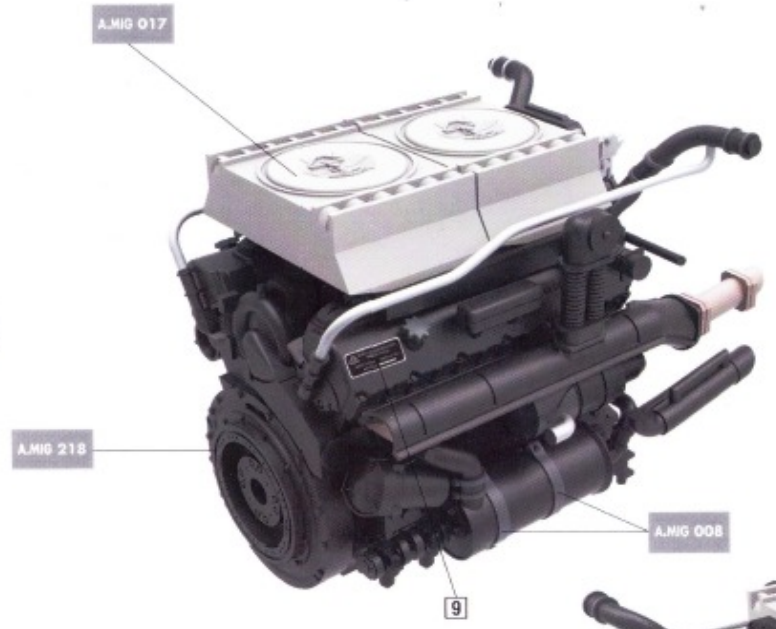

9



A.MIG 194



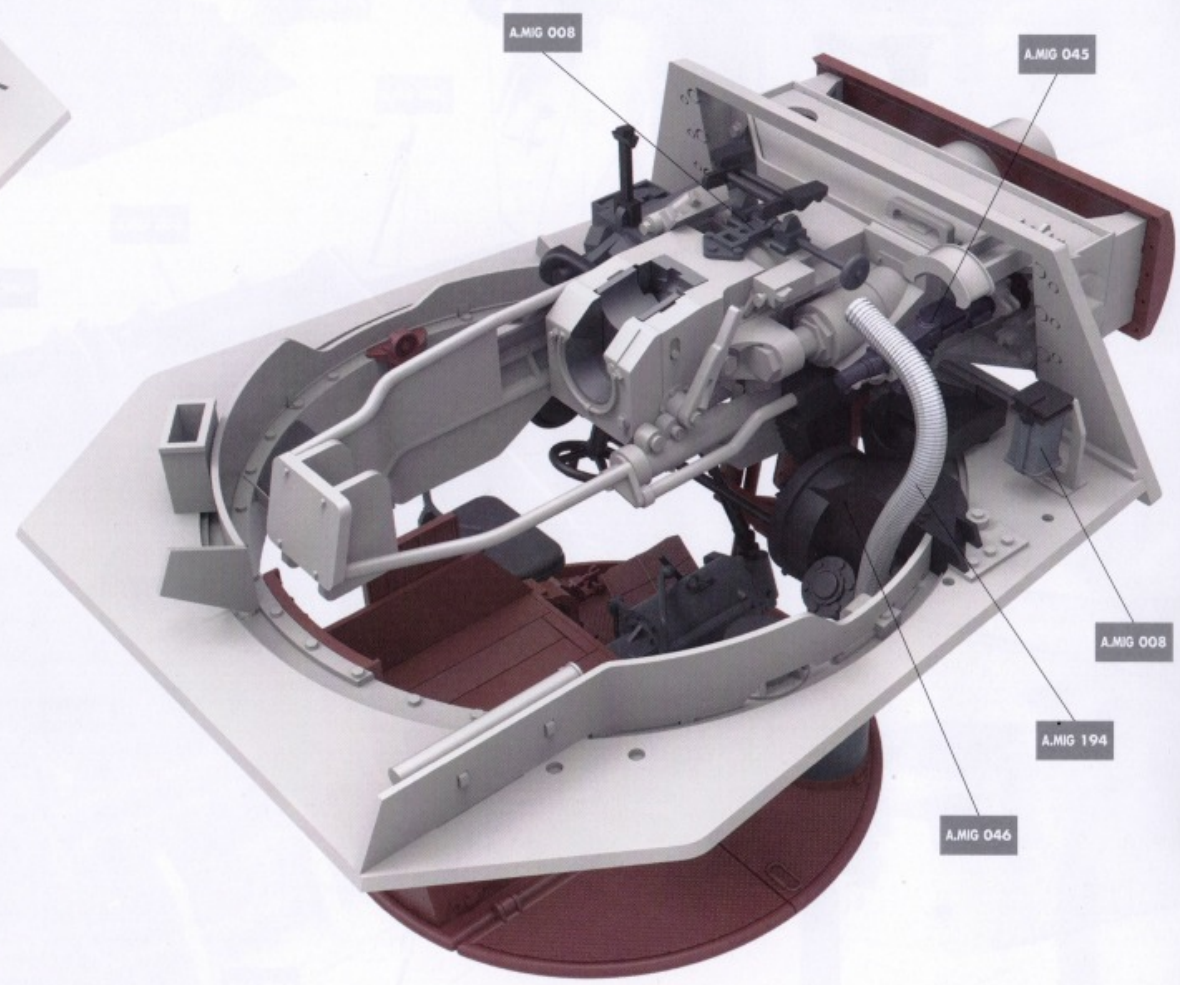



# READ BEFORE ASSEMBLY

## CAUTION

- Read carefully and fully understand the instructions before commencing assembly. A supervising adult should also read the instructions if a child assembles the model.
- When assembling this kit, tools including knives used. Extra care should be taken to avoid personal injury.
- Keep out of reach of small children. Children must not be allowed to suck any part, or pull vinyl bag over their heads.



Optional



Remove



Drill

## PAINTS REQUIRED

Color info and profiles by Mig Jimenez

A.MIG 033	Rubber & Tires	A.MIG 035	Dark Tracks	A.MIG 036	Old Wood	A.MIG 038	Old Wood
A.MIG 040	Medium Rust	A.MIG 045	Gun Metal	A.MIG 063	Crystal Red	A.MIG 096	Crystal Periscope Green
A.MIG 010	Dunkelgelb Mid war	A.MIG 015	Schokobraun	A.MIG 002	Olivgrun Opt.2		

## APPLYING DECALS

1. Clean the model surface with a wet cloth.
2. Cut out each decal design from sheet, and dip it in tepid water for 15~20 sec.
3. Hold the backing sheet edge and slide decal onto the model.
4. Move decal into position by wetting decal with finger.
5. Press decal gently down with a soft cloth until excess water and air bubbles are gone.

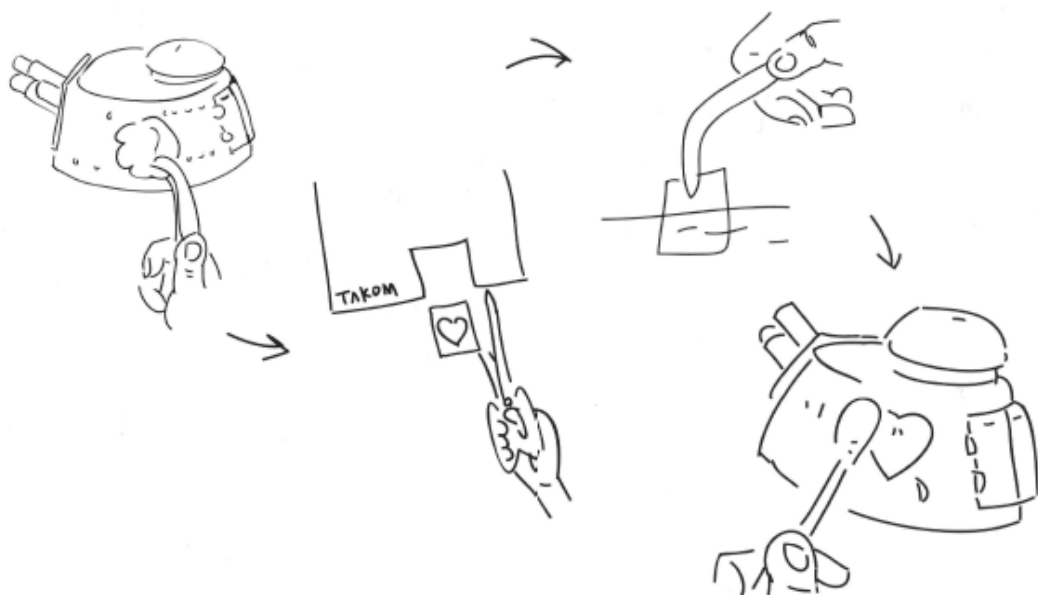

## REMOVING PE

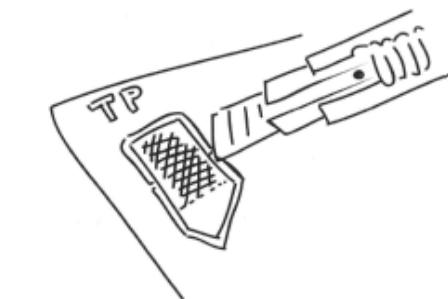

Be careful not to hurt when removing PE parts.

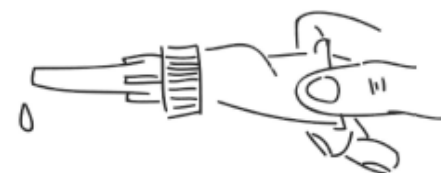

Secure using instant glue (not included).

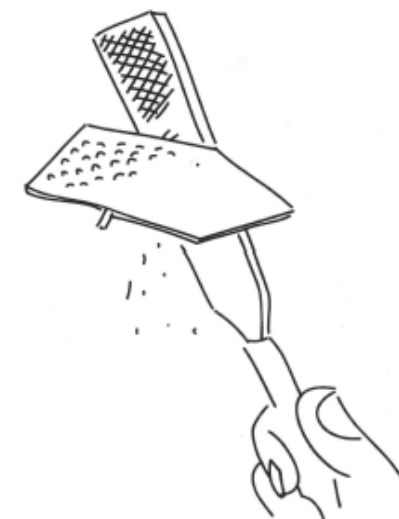

Finish using file.