

Hurricane IID. 6 Squadron RAF, Egypt, 1942.

"The Flying Tin Openers"

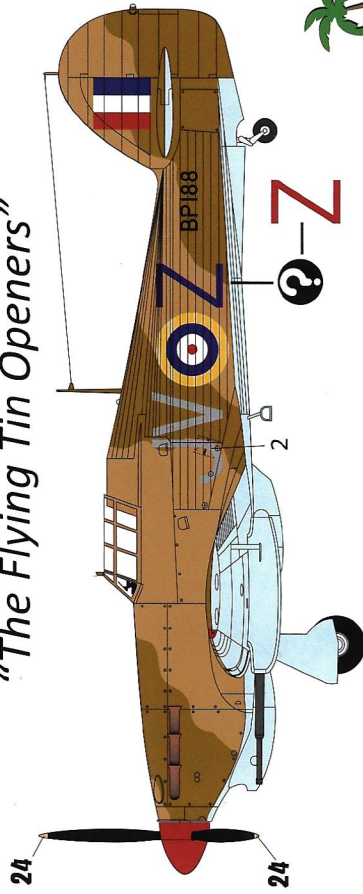

VICTORY IN THE DESERT

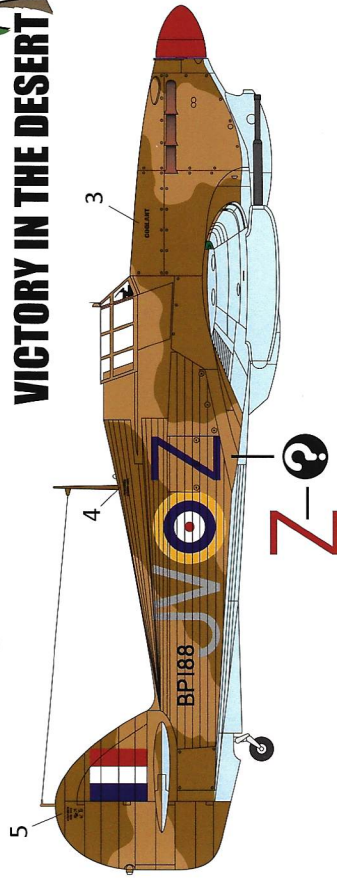

**Version 1
Summer 1942**

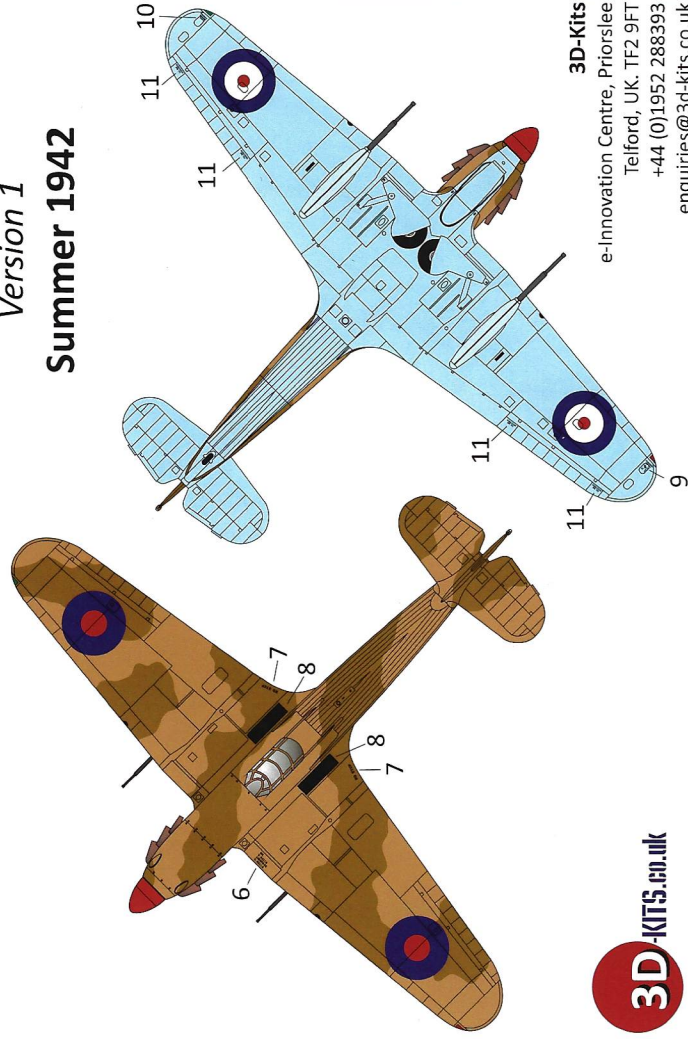

Humbrol paint reference numbers



Trainer Yellow
Black
Dull Red

RAF Mid Stone
RAF Dark Earth

RAF Azure Blue
Sky Blue

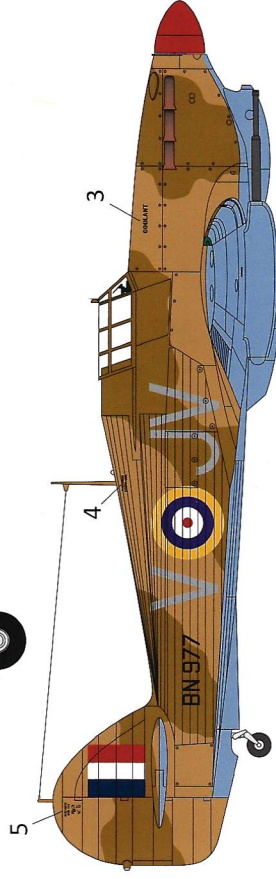
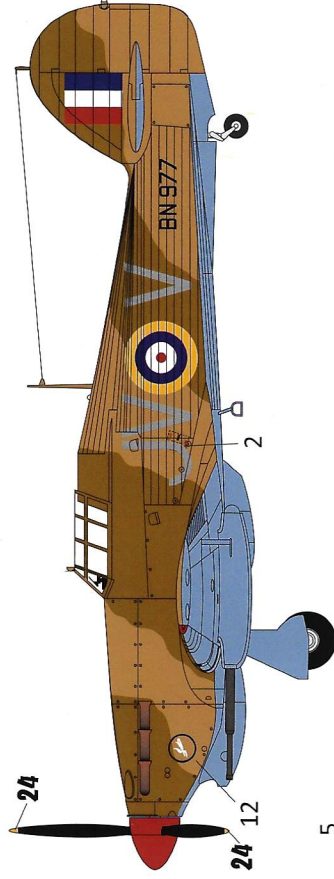

**Version 2
Late 1942**

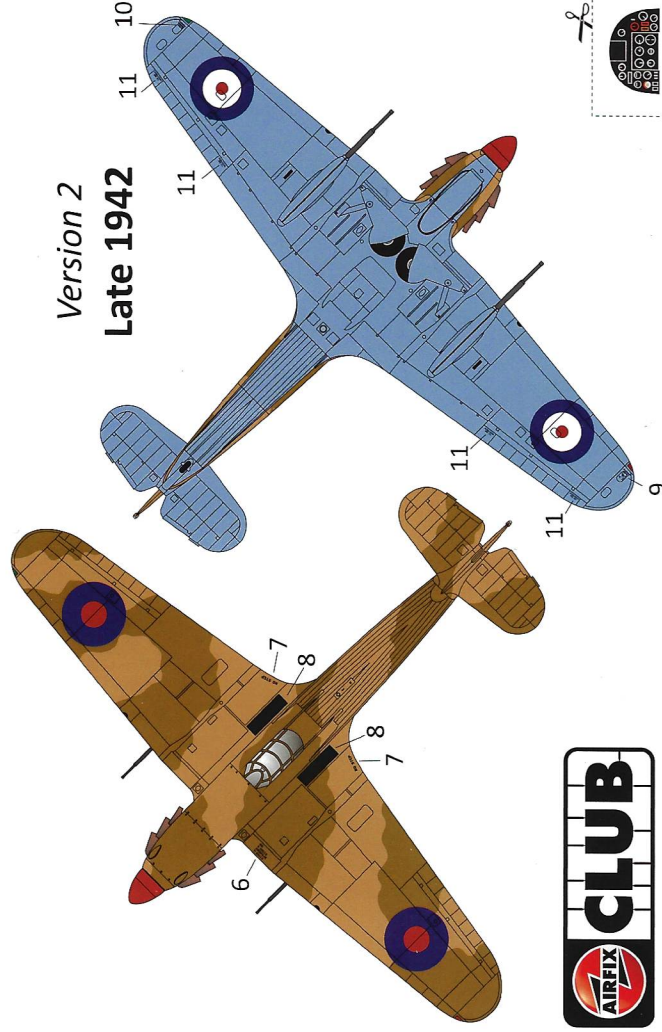

VICTORY IN THE DESERT

Hurricane IIDs, El Alamein

The Hawker Hurricane was regarded as one of the most rugged and reliable aircraft to be used by the RAF in WWII. Starting life as a fighter it developed into a ground attack aircraft. The Mk IID was a specialist anti-tank version and was the first big gunned tank buster to be used in the war. It was armed with two 40mm Vickers cannon firing armour piercing shells and two 0.303 machine guns used to sight the big guns and to give limited self defence in air-to-air combat.

The Hurricane IID was first used in North Africa in summer 1942 and continued to be used throughout the campaign. It equipped 6 Squadron RAF and 7 Squadron of the South African Air Force, where it was found to be very effective at destroying Axis armour and vehicles, with 6 Squadron becoming known as the Flying Tin Openers because of their success. The Hurricane IID was used extensively before and during the Battle of El Alamein where it destroyed or damaged many enemy vehicles, including captured British tanks.

ASSEMBLY INSTRUCTIONS

Follow the Airfix kit instructions, except where shown below.

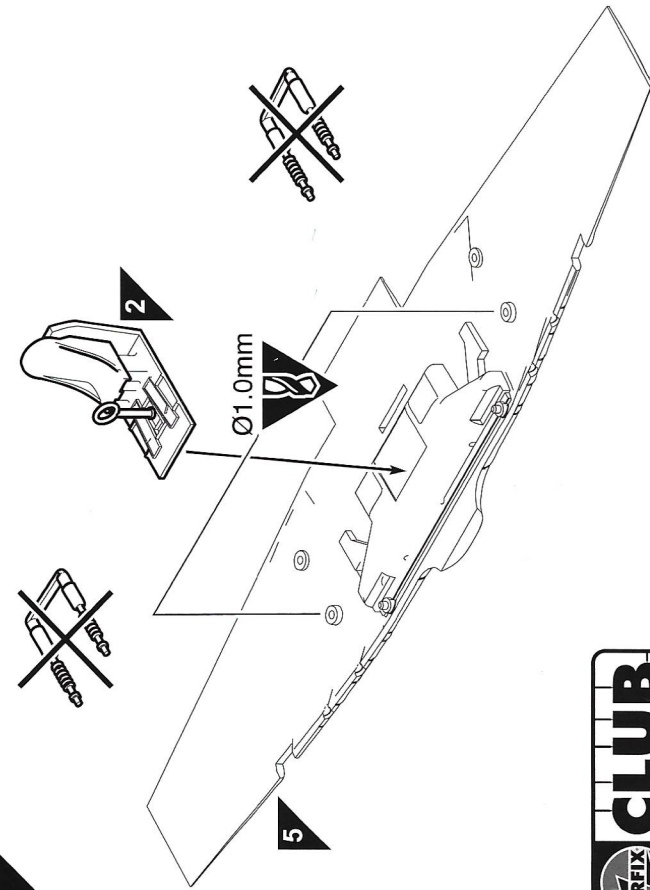

6

7a
= Fill & smooth off

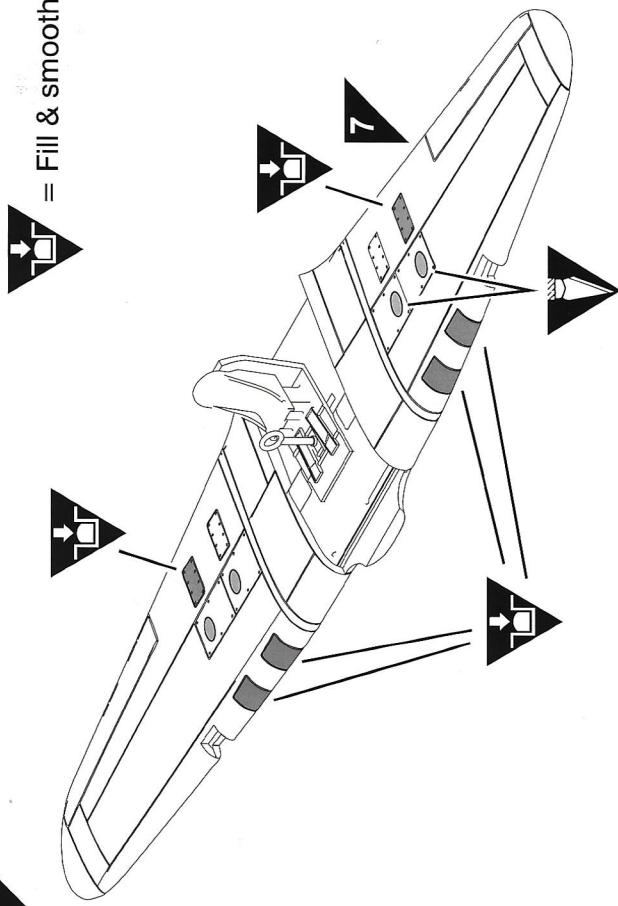

7a

10a

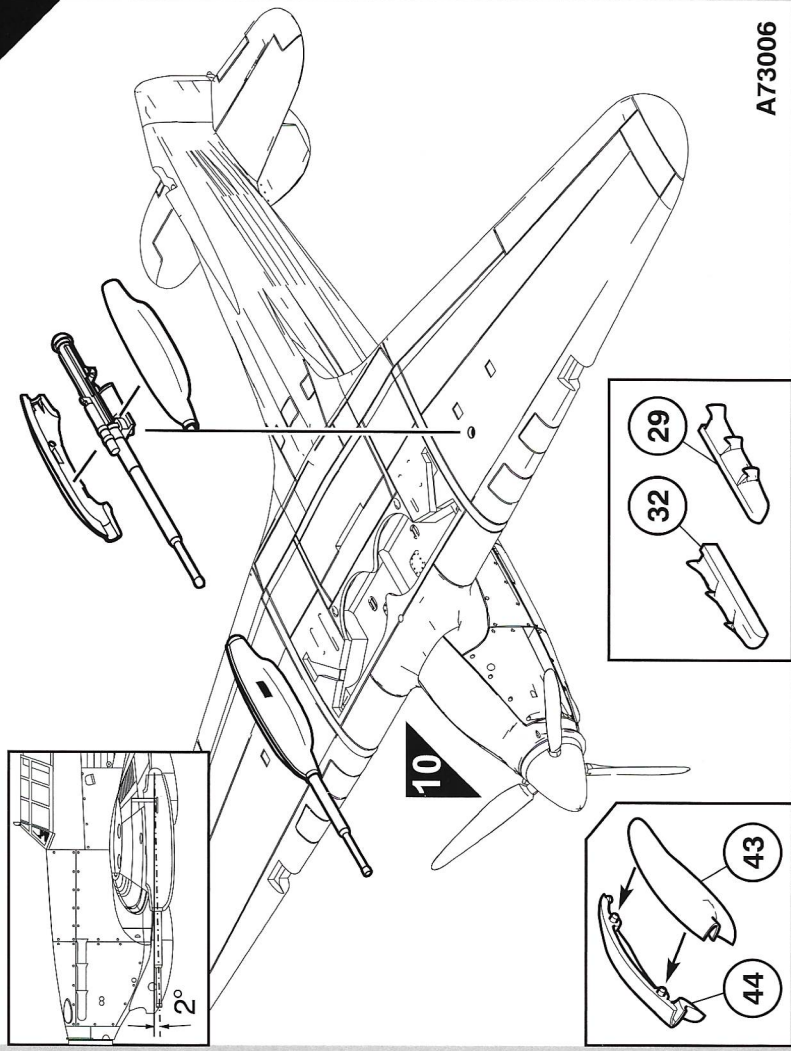

A73006