

# Dornier Do 27 A/B

## German Armed Forces – Colour and Decal Application Guide



We are right beside you!

**1**

**Dornier Do 27 B-1, PB+105 HFlgStff. 2, Werknr. 129, Fritzlar 1960**

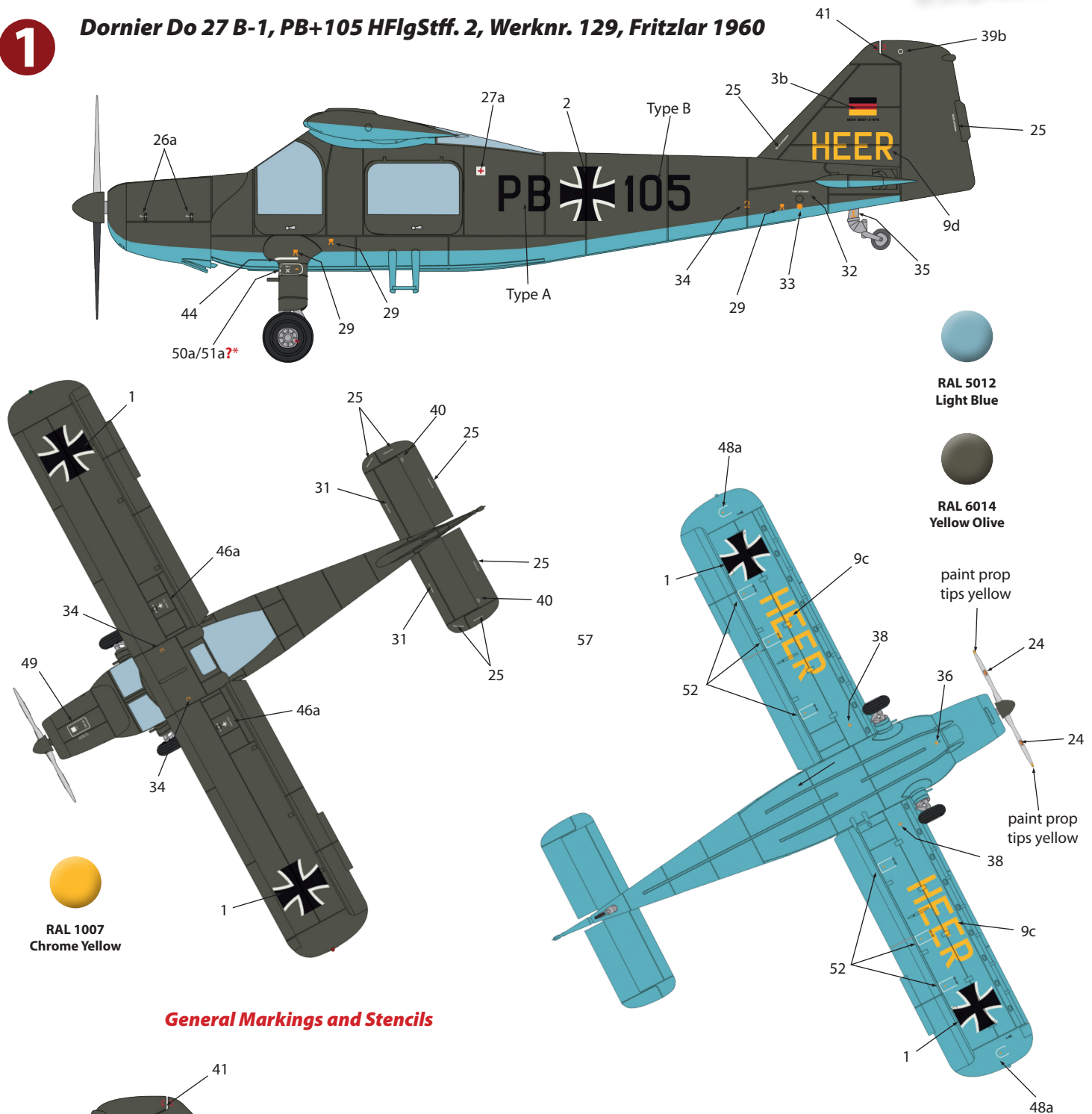

### General Markings and Stencils

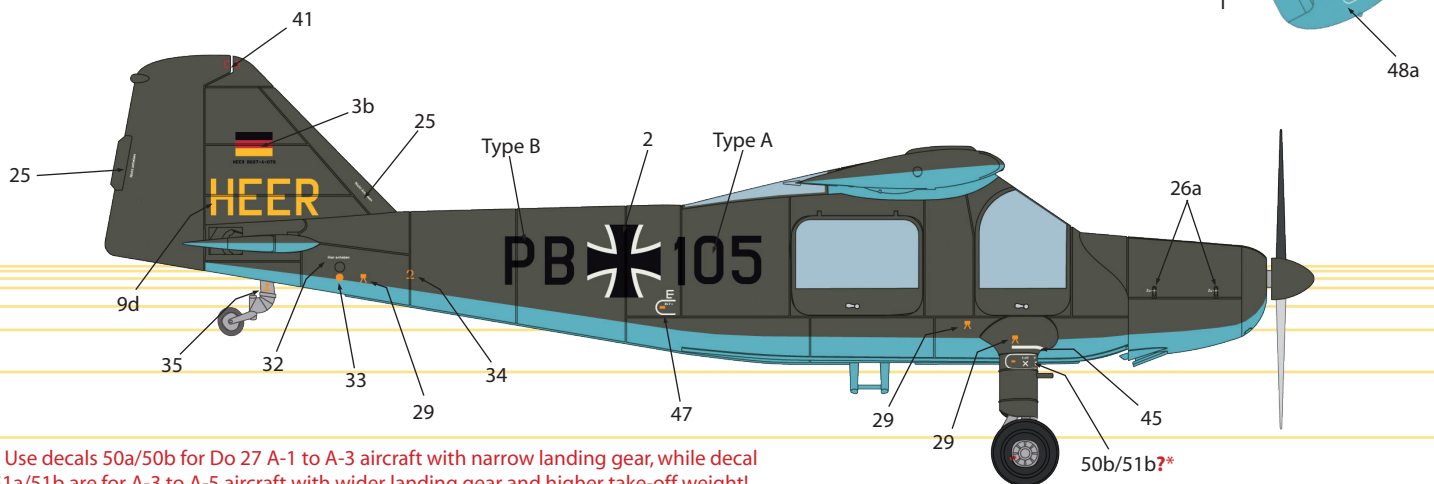

\* Use decals 50a/50b for Do 27 A-1 to A-3 aircraft with narrow landing gear, while decal 51a/51b are for A-3 to A-5 aircraft with wider landing gear and higher take-off weight!

2

**Dornier Do 27 A-1, PL+107, HFlgStff. 11, Werknr. 163, Celle, 1961**

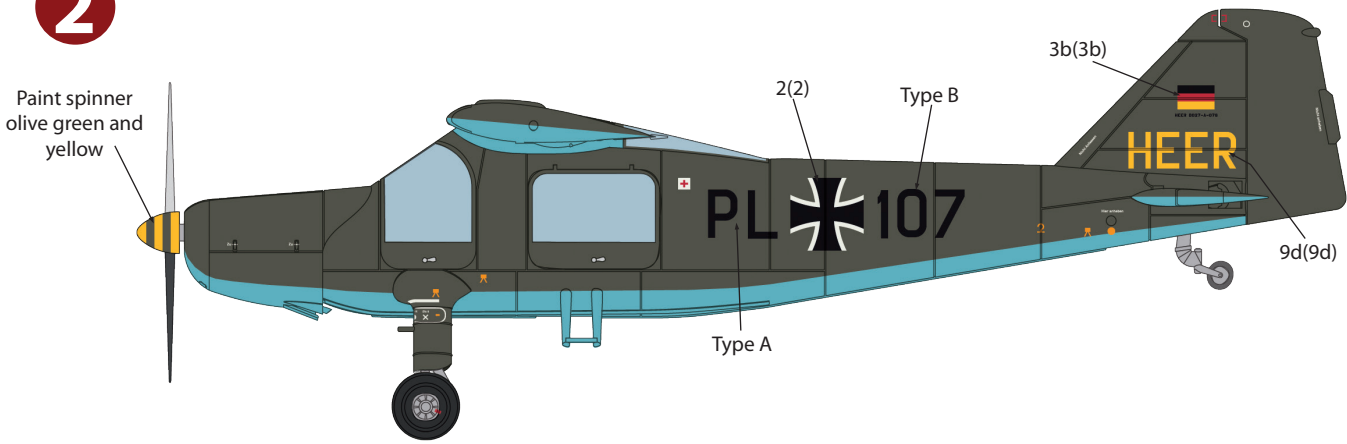

3

**Dornier Do 27 A-4, LB+163, 2. LwRetuVerbStff., Werknr. 512, Lechfeld 1962**

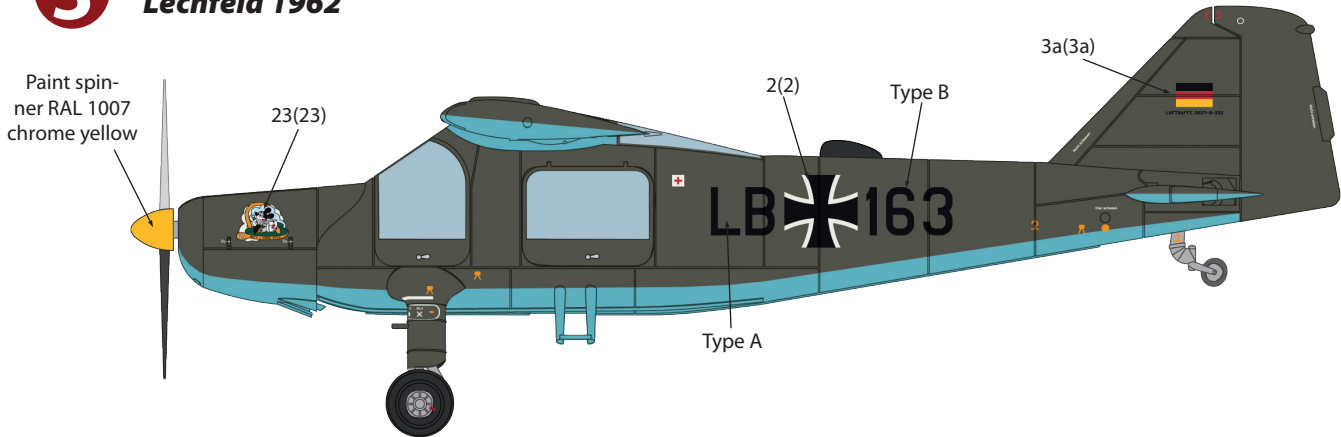

4

**Dornier Do 27 A-1, AS+923, Werknr. 173, Ausbildungsgruppe B "Mufti-Staffel", FFS 'S', Wunstorf 1961**

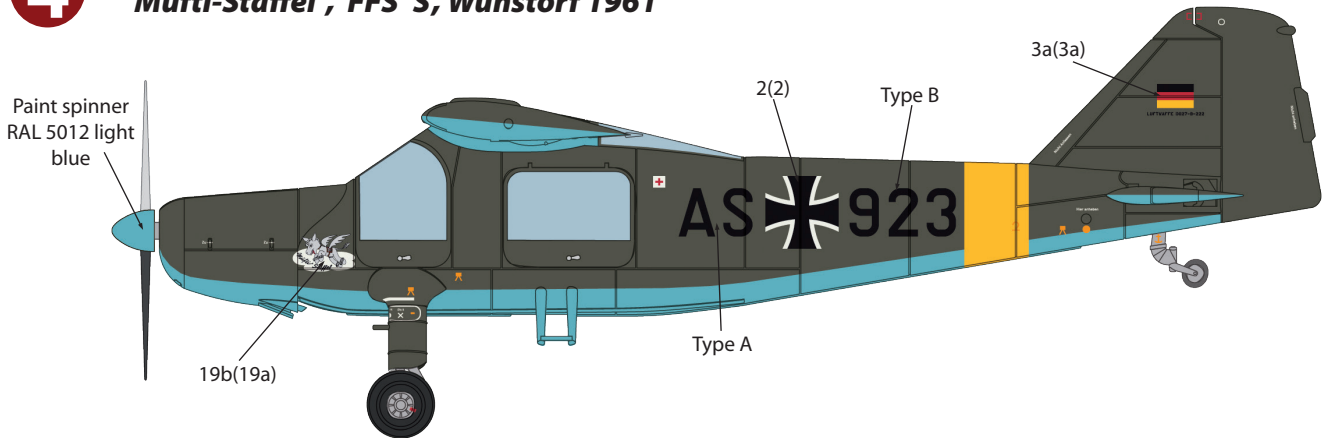

5

**Dornier Do 27 A-1, MA+901, Werknr. 312, "Schleppflieger" BwSpFlgGrp. IeKG41, Husum 1967**

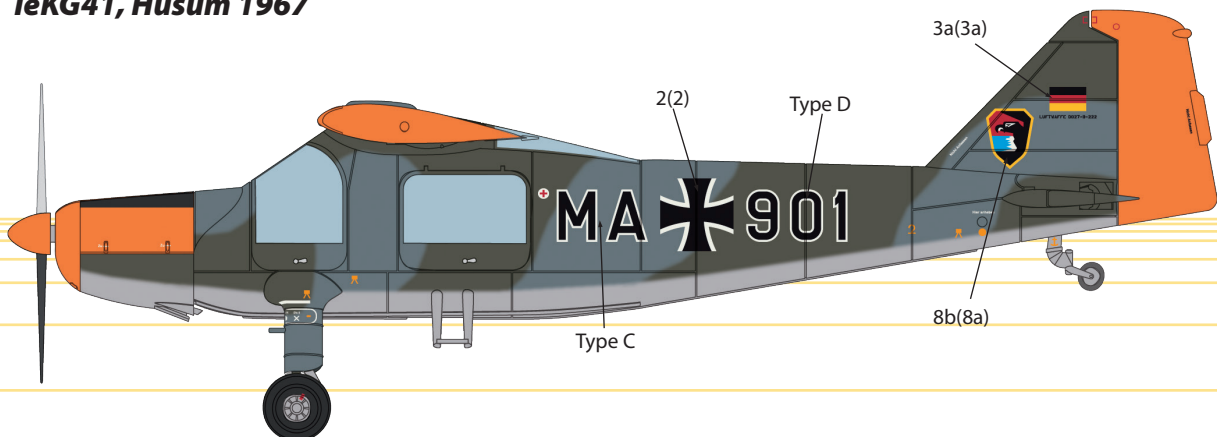

**6** *Dornier Do 27 A-1, MD+901, Werknr. 348, "Schleppflieger" BwSpFlgGrp. IeKG44, Leipheim 1967*

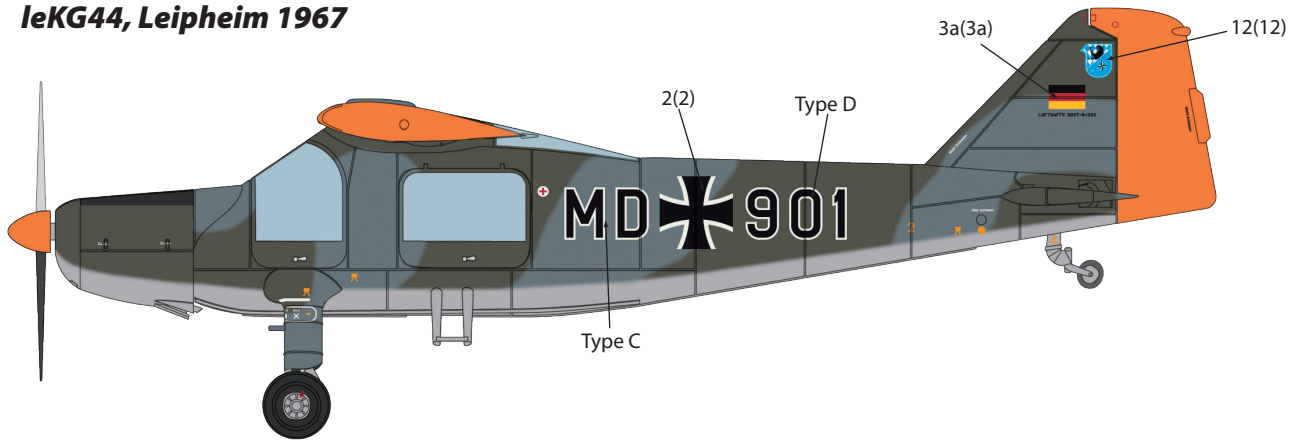

**7** *Dornier Do 27 A-3, ND+109, Werknr. 447, LwGrp. Süd - Karlsruhe, Personal mount of Gen. Johannes Trautloff, Neubiberg 1964*

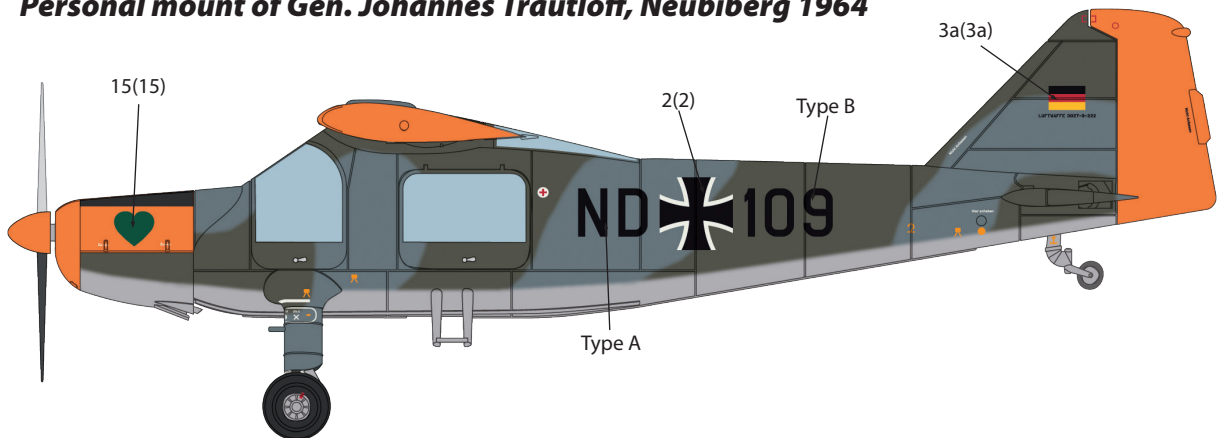

**8** *Dornier Do 27 A-1, 55+36, WerkNr. 160, WaSLw50, Fürstenfeldbruck 1970*

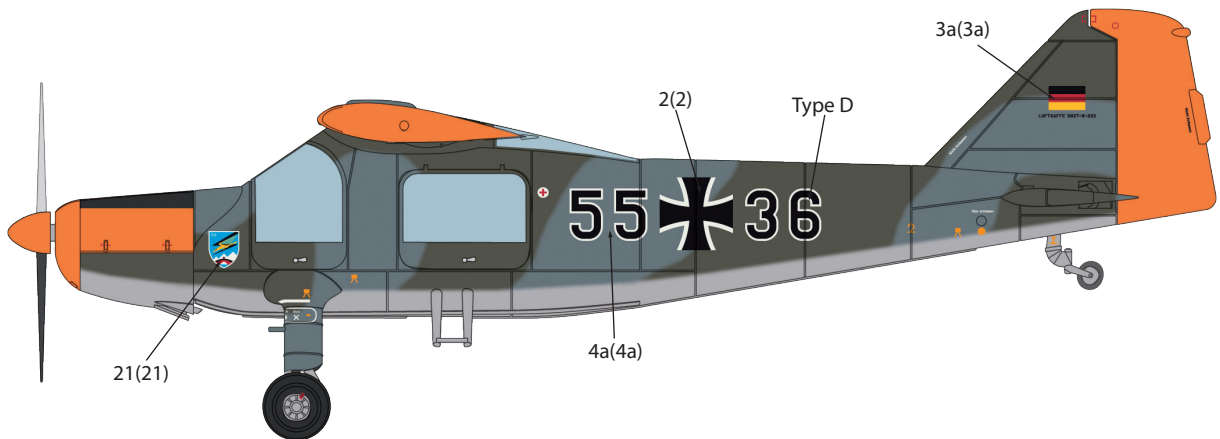

**9** *Dornier Do 27 A-1, 55+43, WerkNr. 172, BwSpFlgGrp. LTG 61, Penzing 1976*

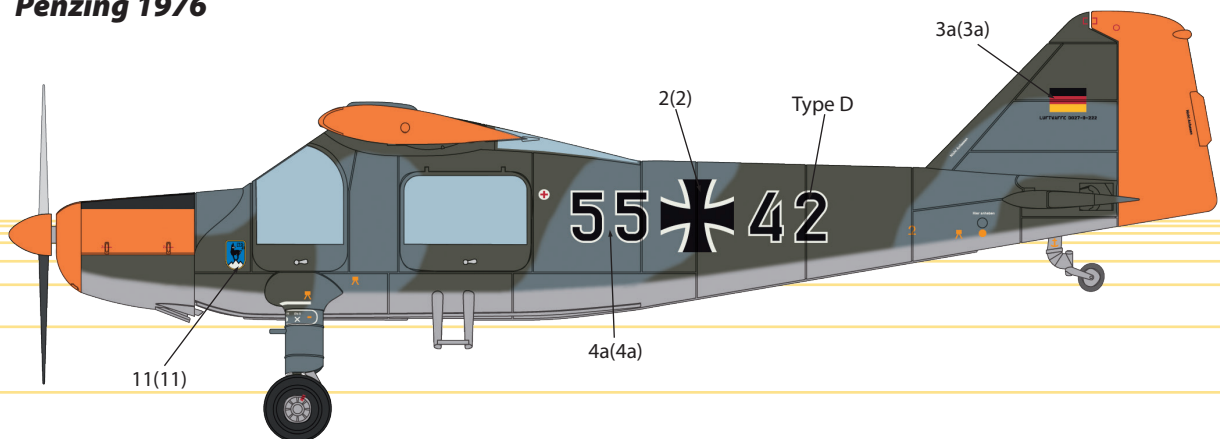

10

**Dornier Do 27 B-1, 55+76, WerkNr. 222, BwSpFlgGrp. IeKG43, Oldenburg 1972**

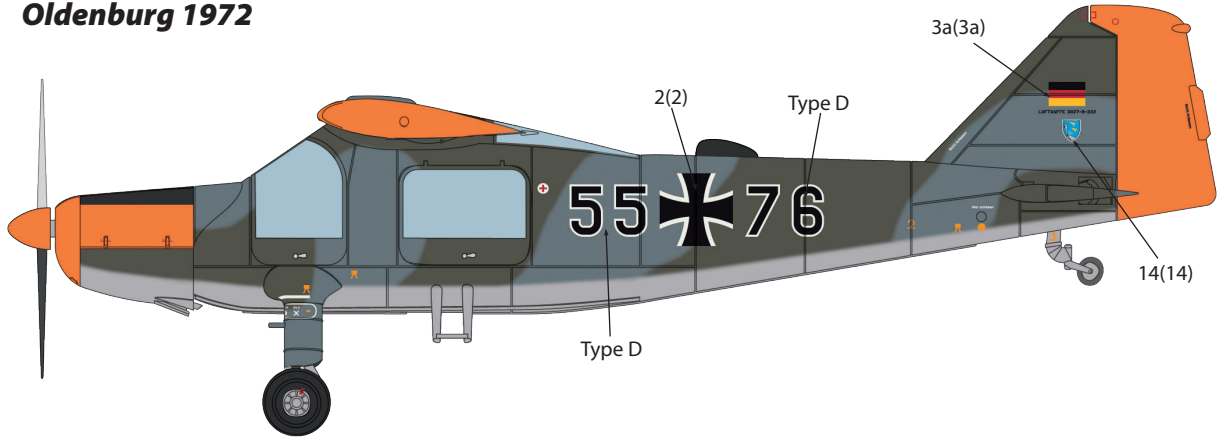

11

**Dornier Do 27 A-1, 56+03, WerkNr. 270, BwSpFlgGrp. JaboG 34, Memmingen 1975**

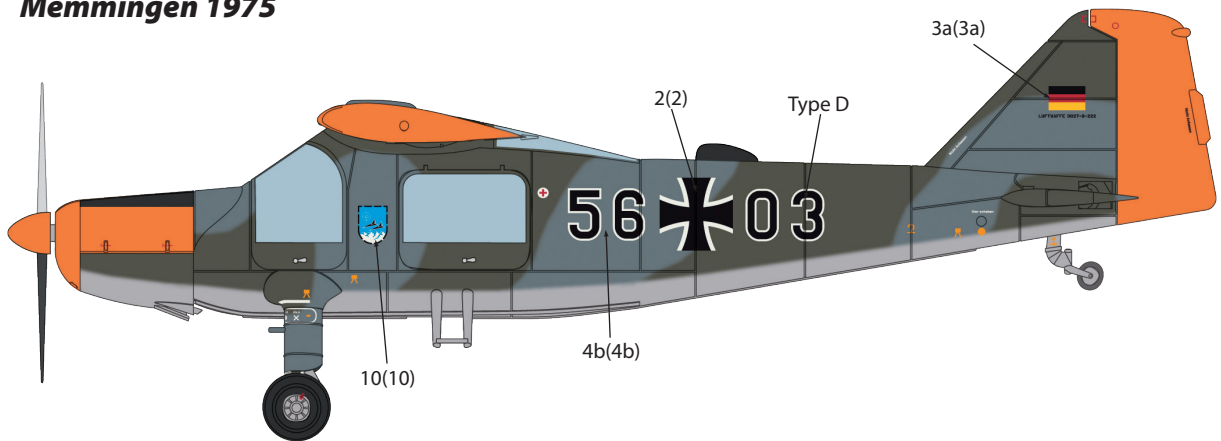

12

**Dornier Do 27 A-1, 56+42, WerkNr. 323, BwSpFlgGrp. E.Stelle 61, Manching 1979**

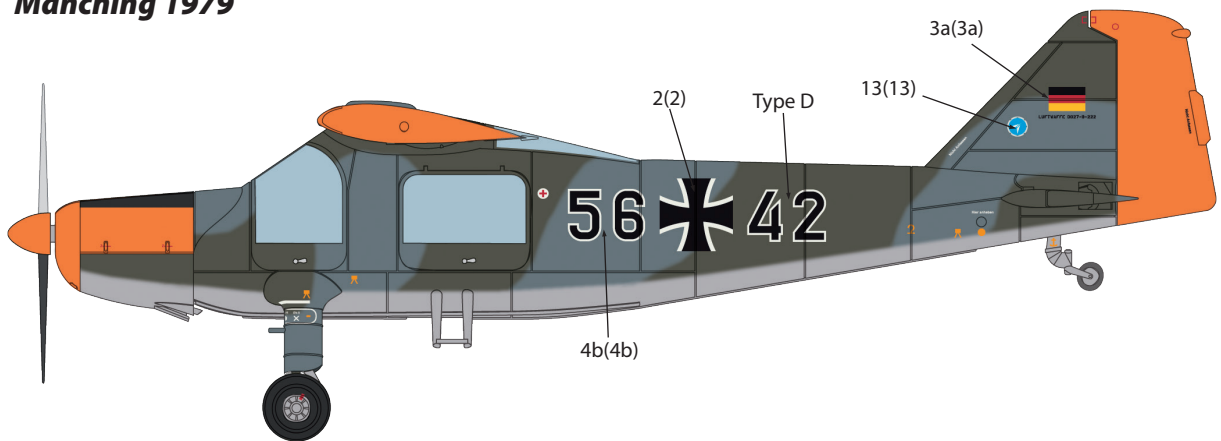

13

**Dornier Do 27 A-3, 56+42, WerkNr. 367, BwSpFlgGrp. AG 51 "Immelmann", Bremgarten 1980**

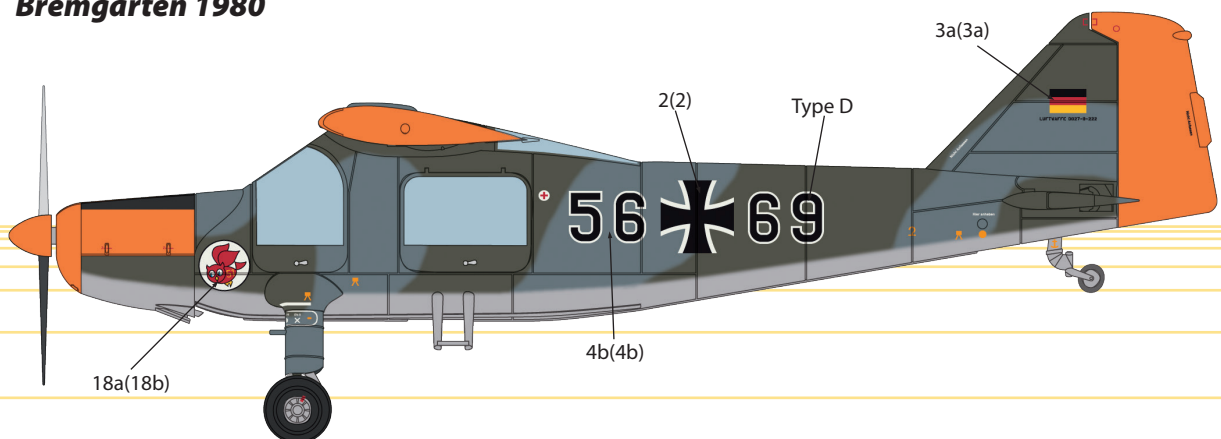

14

**Dornier Do 27 A-5, 57+28, WerkNr. 457 , 2./HFB 6, Itzehoe 1969**

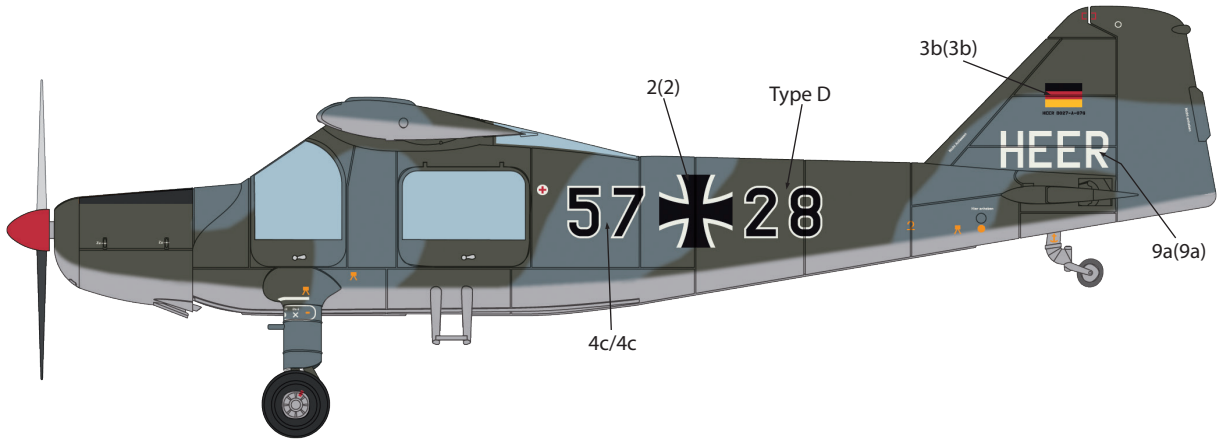

15

**Dornier Do 27 A-3, 56+03, WerkNr. 465, BwSpFlgGrp. JaboG 35, Pferdsfeld 1979**

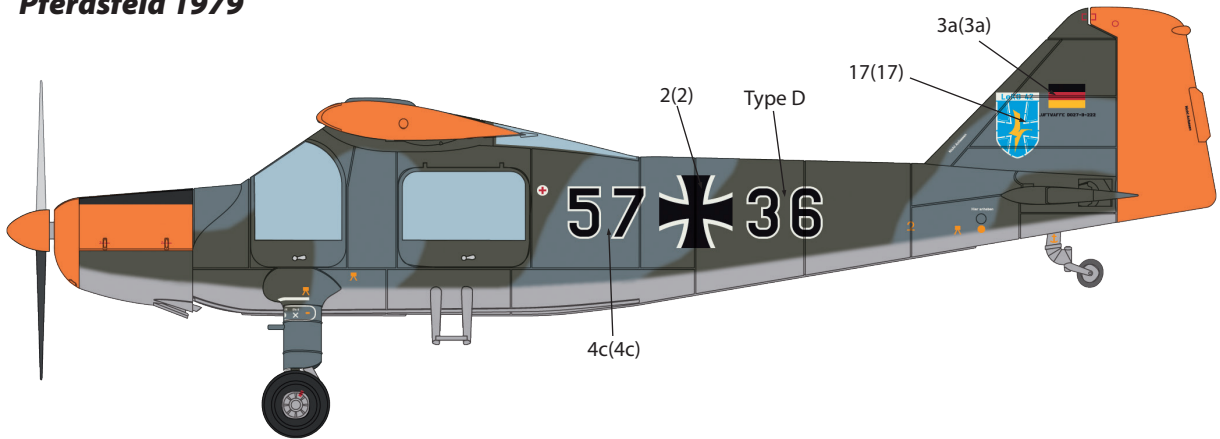

16

**Dornier Do 27 A-3, 56+03, WerkNr. 466, BwSpFlgGrp. JaboG 31 "Boelcke, Nörvenich 1977**

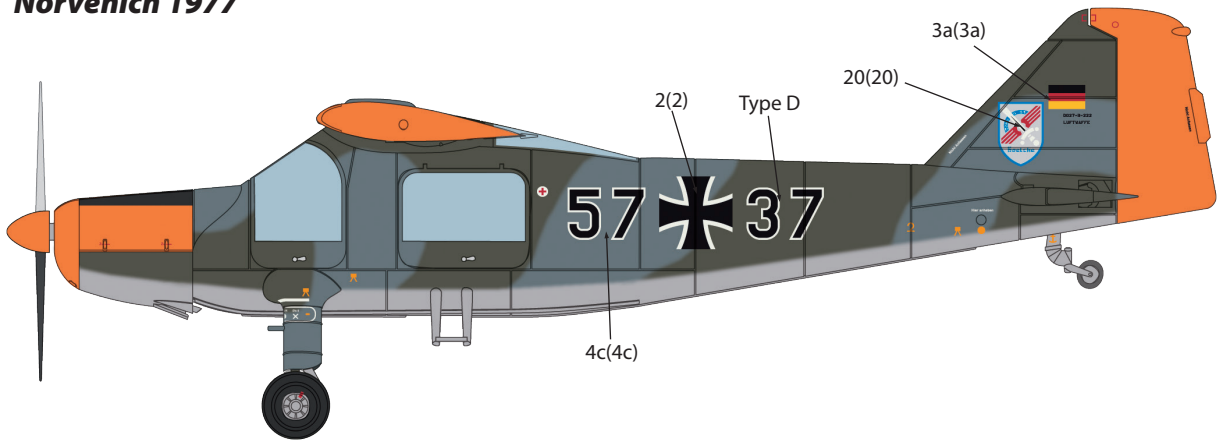

17

**Dornier Do 27 A-1, 56+03, WerkNr. 601, BwSpFlgGrp. MFG 5, Kiel-Holtenau 1978**

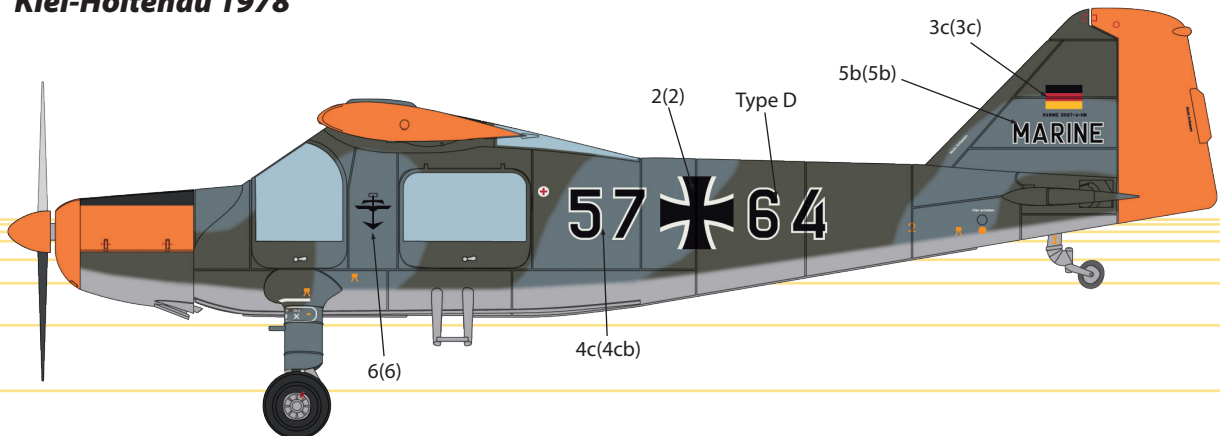

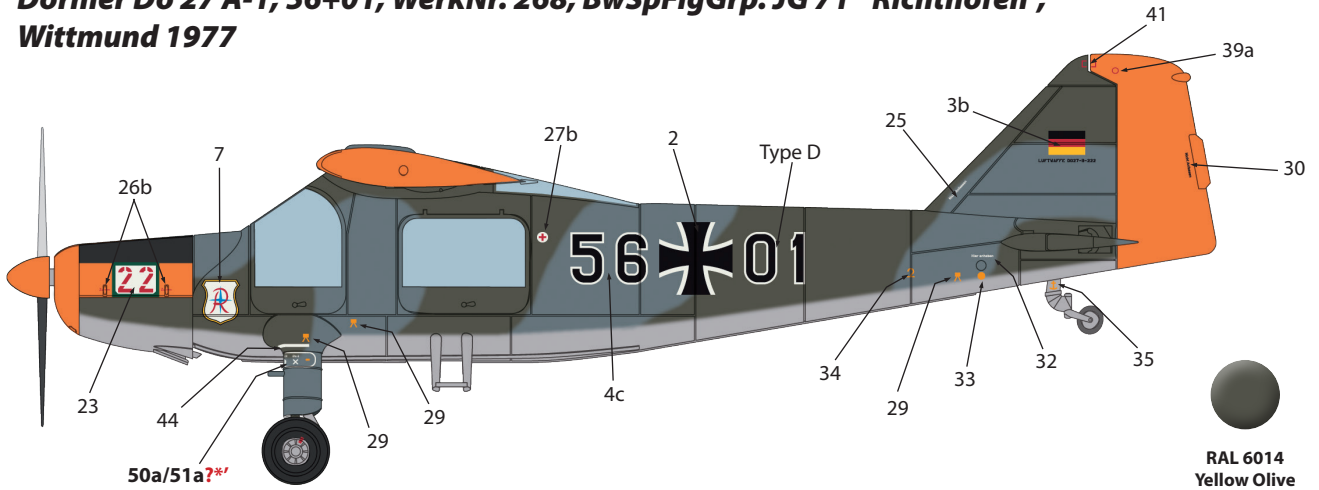

**RAL 6014**  
Yellow Olive

**RAL 7001**  
Silver Grey

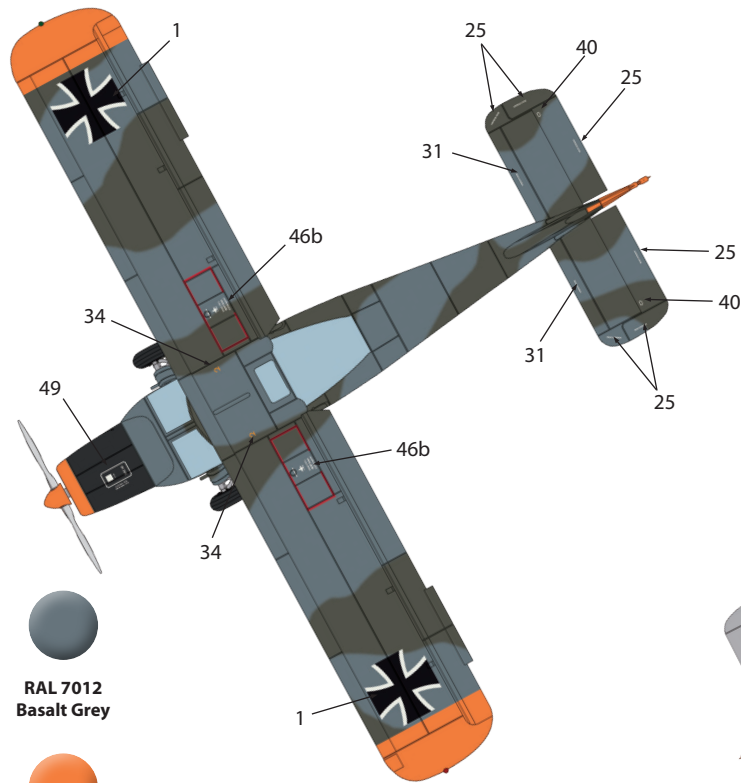

**RAL 7012**  
Basalt Grey

**RAL 2005**  
Dark Dayglo  
Orange  
(LifeColor LC 55)

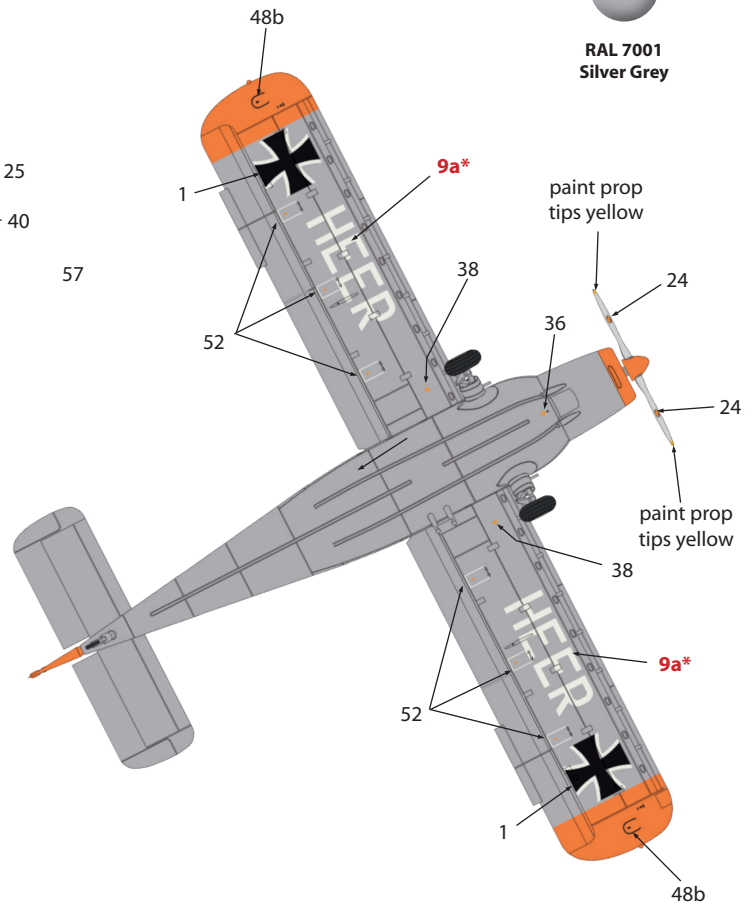

**General Markings and Stencils**

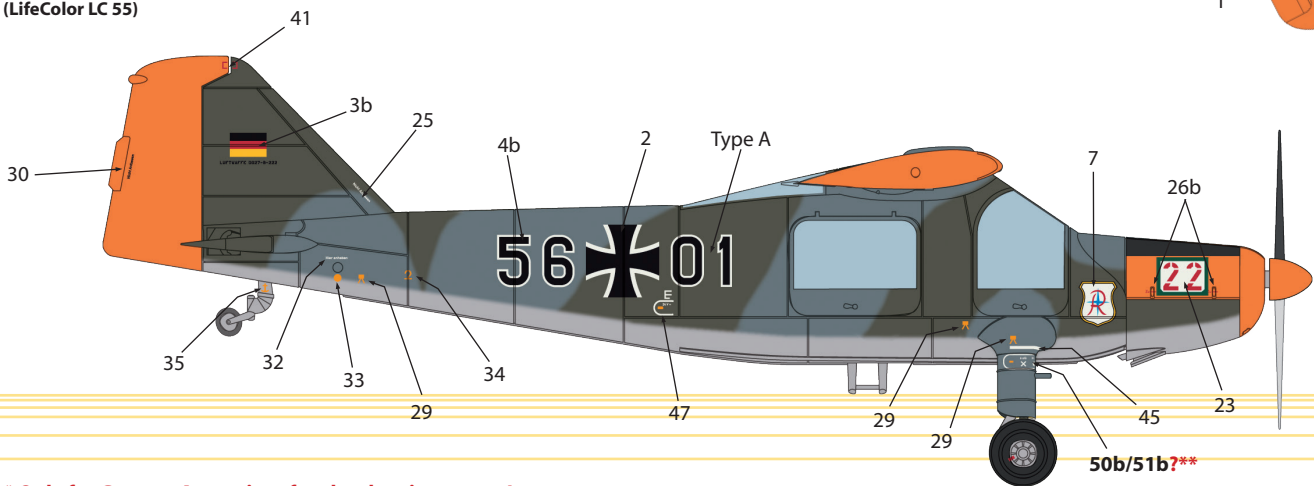

**\* Only for German Army aircraft – decal variant no. 14!**

**\*\* Use decals 50a/50b for Do 27 A-1 to A-3 aircraft with narrow landing gear, while decal 51a/51b are for A-3 to A-5 aircraft with wider landing gear and higher take-off weight!**



**Dornier Do 27 A-1, 55+43,  
WerkNr. 172, BwSpFlgGrp.  
LTG 61,  
Penzing 1976**

**Dornier Do 27 A-1,  
55+36, WerkNr. 160,  
WaSLw50, Fürstenfeld-  
bruck 1970**



**Dornier Do 27 B-1,  
55+76, WerkNr. 222,  
BwSpFlgGrp. IeKG43,  
Oldenburg 1972**

**Dornier Do 27 A-1,  
56+01, WerkNr. 268,  
BwSpFlgGrp. JG 71 "Rich-  
thofen", Wittmund 197**





**Dornier Do 27 A-3, 56+42,  
WerkNr. 367, BwSpFlg-  
Grp. AG 51 "Immelmann",  
Bremgarten 1980**

**Dornier Do 27 A-1,  
56+16, WerkNr. 284,  
BwSpFlgGrp. MFG 5,  
Kiel-Holtenau 1969**



**Dornier Do 27 A-3,  
56+03, WerkNr. 466,  
BwSpFlgGrp. JaboG 31  
"Boelcke,  
Nörvenich 1977**



**Dornier Do 27 A-3,  
56+03, WerkNr. 465,  
BwSpFlgGrp. JaboG 35,  
Pferdsfeld 1979**

