

BOEING E-3 A/C AWACS



80308

F

L'E3 Awacs (Système aéroporté d'alerte et de surveillance) est un appareil qui permet de remédier aux difficultés de repérage des avions ennemis volant à basse altitude et donc masqués par le relief naturel. Sa cellule est celle d'un 707-320B civil. Il est équipé d'un radôme rotatif contenant les antennes du radar et d'un système d'identification ami-ennemi. L'E-3 Awacs est un centre de commandement, de contrôle et de communications doté d'une forte capacité de survie et capable de résister à un brouillage intense. Il est en service dans l'US Air Force depuis 1977.

CARACTERISTIQUES

Longueur : 46,68 m
 Envergure : 44,45 m
 Hauteur : 12,70 m
 Réacteurs : 4 Pratt & Whitney TF33-PW-100A

GB

The E-3 Awacs (Airborne Warning and Control System) is an aircraft designed to detect low-flying enemy planes, which are difficult to distinguish from natural features on the ground. Its airframe is a civilian 707-320B which has been equipped with a rotating radome containing radar antennas and a friend enemy identification system. The E-3 Awacs is a command, control and communications center endowed with high survival capacity and able to overcome intense jamming. It has been in service with the US Air Force since 1977.

SPECIFICATIONS

Length : 46.68 m
 Wingspan : 44.45 m
 Height : 12.70 m
 Engines : 4 Pratt & Whitney TF33-PW-100A

D

Der E-3 Awacs (Luftlandewarn - und Überwachungssystem) ist eine Maschine, die die Schwierigkeiten bei der Ortung feindlicher Flugzeuge beseitigt, die in niedriger Höhe fliegen und so von der Bodenbeschaffenheit verdeckt werden. Die Flugzelle ist die einer zivilen 707-320B. Er ist mit einem drehbaren Radom ausgestattet, das die Radarantenne und ein Freund-Feind Identifizierungssystem enthalten. Der E-3 B Awacs ist ein Kommando-, Kontrolle und Kommunikationszentrum und ist von großer Überlebensfähigkeit. Er kann sogar intensiven Störversuchen widerstehen. Er ist seit 1977 in der US Air Force im Einsatz.

TECHNISCHE DATEN

Länge : 46,68 m
 Spannweite : 44,45 m
 Höhe : 12,70 m
 Triebwerke : 4 Pratt & Whitney TF33-PW-100A

E

El E-3 Awacs (Sistema aero-portado de alerta y vigilancia) es un aparato que permite solucionar dificultades de localización de los aviones enemigos que vuelan a baja altura, y por lo tanto ocultos por el relieve natural. Su estructura es la de un 707-320B civil y se halla equipado de un « radome » giratorio que contiene las antenas del radar y de un sistema de identificación amigo-enemigo. El E-3 Awacs es un centro de mando, de control y de comunicación dotada de una fuerte capacidad de supervivencia y capaz de resistir a una intensa interferencia. Está en servicio en la US Air Force desde 1977.

CARACTERÍSTICAS

Longitud : 46,68 m
 Envergadura : 44,45 m
 Altura : 12,70 m
 Reactores : 4 Pratt & Whitney TF33-PW-100A

NL

De E-3 Awacs (airborne warning and control system) is een apparaat dat het probleem oplost om laagvliegende, vijandige vliegtuigen, die door het natuurlijke reliëf gemaskeerd worden, op te sporen. Het apparaat heeft de bouw van een burger 707-320B en is uitgerust met een (draaibare radarkoepel met radarantennes en een) vriendvijand herkenningssysteem. De E-3 Awacs is een commando, controle- en communicatiecentrum met een groot overlevingsvermogen en in staat om intense storingen te weerstaan. Het is sinds 1977 in bedrijf bij de US Air Force.

EIGENSCHAPPEN

| | |
|------------|----------------------------------|
| Lengte | : 46,68 m |
| Spanwijdte | : 44,45 m |
| Hoogte | : 12,70 m |
| Reactoren | : 4 Pratt & Whitney TF33-PW-100A |

IT

L'E-3 Awacs (sistema aviotrasportato di allarme e sorveglianza) è un apparecchio che permette di rimediare alle difficoltà di localizzazione degli aerei nemici che volano a bassa quota e sono quindi mascherati dal rilievo naturale. La cellula è quella di un 707-320B civile ed è fornita di un « radome » rotante contenente le antenne del radar e di un sistema di identificazione amico-nemico. L'E-3 Awacs è un centro di comando, di controllo e di comunicazione dotato di una forte capacità di sopravvivenza e capace di resistere a intensi disturbi. E' in servizio nell'US Air Force dal 1977.

CARATTERISTICHE

| | |
|----------------|----------------------------------|
| Lunghezza | : 46,68 m |
| Apertura alare | : 44,45 m |
| Altezza | : 12,70 m |
| Reattori | : 4 Pratt & Whitney TF33-PW-100A |

P

O E-3 Awacs « sistema » aerotransportado de alerta e de vigilância » é um equipamento que permite evitar as dificuldades de identificação dos aviões inimigos a voar em baixa altitude e portanto escondidos pelo relevo natural. A sua célula é a de um 707-320 B civil e ele está equipado com um radome rotativo contendo as antenas do radar e de um sistema de identificação amigo-inimigo. O E-3 Awacs é um centro de comando, de controlo e de comunicações dotado de uma grande capacidade de sobrevivência e capaz de resistir a interferências intensas. É utilizado na US Air Force desde 1977.

ESPECIFICAÇÕES

| | |
|-------------|----------------------------------|
| Comprimento | : 46,68 m |
| Envergadura | : 44,45 m |
| Altura | : 12,70 m. |
| Reactores | : 4 Pratt & Whitney TF33-PW-100A |

S

E-3 Awacs (Airborne Warning and Control System) gör det möjligt att upptäcka plan som flyger på låg höjd och därför döljs av landskapets relief. Planet, vars skrov kommer från en civil 707-320B, är försett med en roterande radom som innehåller radarantennor och ett system som gör det möjligt att skilja mellan vänskapligt och fiendligt flyg. E-3 AWACS fungerar som en stridslednings-, övervaknings- och kommunikationscentral med stor överlevnadskapacitet och god förmåga att klara även intensiva störningsförsök. Planet finns i tjänst vid det amerikanska flygvapnet sedan 1977.

SPECIFIKATIONER

| | |
|------------|----------------------------------|
| Längd | : 46,68 m |
| Vingbredd | : 44,45 m |
| Höjd | : 12,70 m |
| Jetmotorer | : 4 Pratt & Whitney TF33-PW-100A |

PEINTURES ESSENTIELLES / ESSENTIAL PAINTS

14
Bleu brillant
Gloss blue
Glänzend -Blau

22
Blanc brillant
Gloss white
Glänzend-Weiss

33
Noir mat
Matt black
Matt-Schwarz

40
Gris pale brillant
Gloss pale grey
Glänzend-Blassgrau

53
Gris métallique
Gunmetal
Metallgrau

56
Aluminium
Aluminium
Aluminium

71
Chêne satiné
Satin oak
Satin-Eichgrün

85
Noir satiné
Satin black
Seidenmatt-Schwarz



87
Gris acier mat
Matt steel grey
Matt-Stahlgrau

91
Vert noir mat
Matt black green
Matt-Schwarzgrün

130
Blanc satiné
Satin white
Satin Weiss

- Si aucune teinte n'est spécifiée, peindre dans les couleurs de la version choisie. Se reporter aux pages 10 à 15 pour le détail du schéma de peinture.
- When no color is specified, paint the item with colors of chosen version. Refer to pages 10 to 15 for painting pattern.
- Wenn keine Farbe angegeben ist, Teile mit den Farben des gewählten Version. Beachten Sie die Seiten 10 bis 15 für die Lackierung und Markierung.
- Cuando ningún color es especificado, pintarle con los colores del tema de la versión elegida. Vea las páginas 10 a 15 para obtener detalles de pintura.

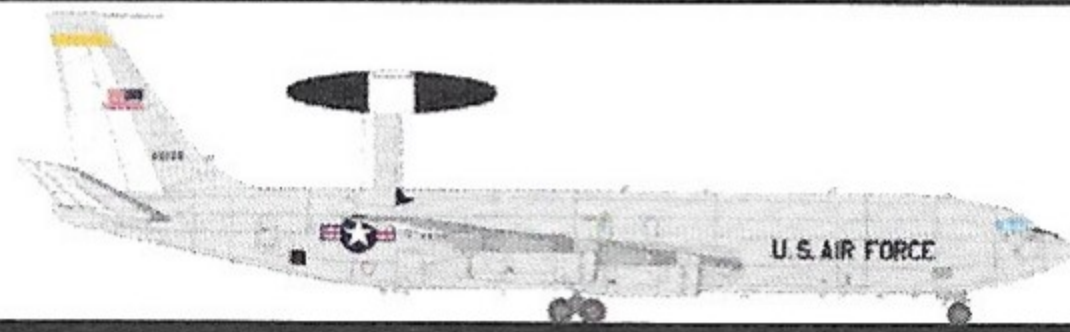
a • BOEING E-3B AWACS



b • BOEING AWACS OTAN 50th An.



2 Numéro de phase
Step number
Schrittnummer
Número de fase

56 Référence de couleur
Colour reference no
Farbangabe
Referencia de color

37 Numéro de pièce
Part number
Teilenummer
Número de pieza

6 Numéro de decal
Decal number
Nummer von Abziehbild
Número de calcomanía

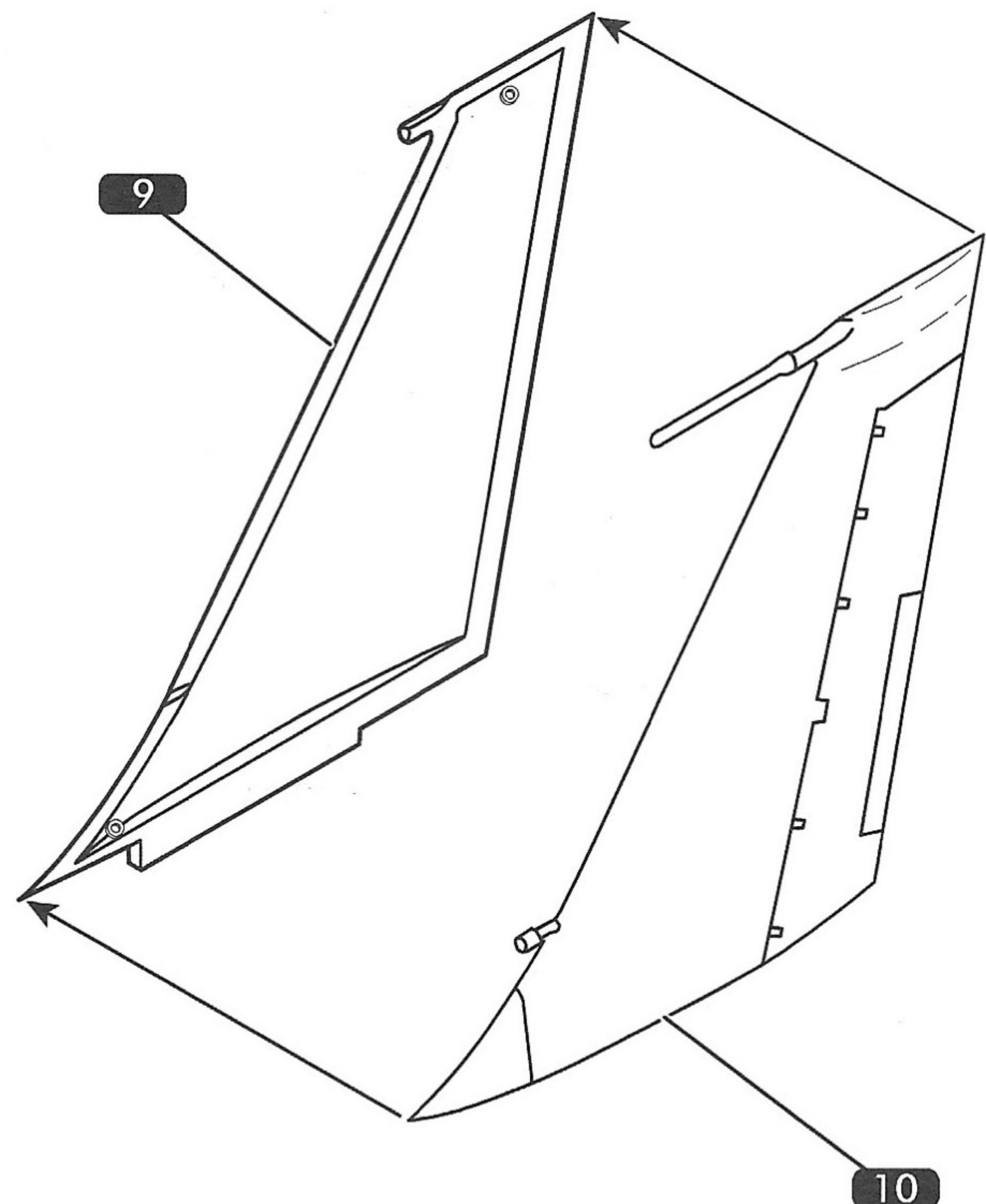
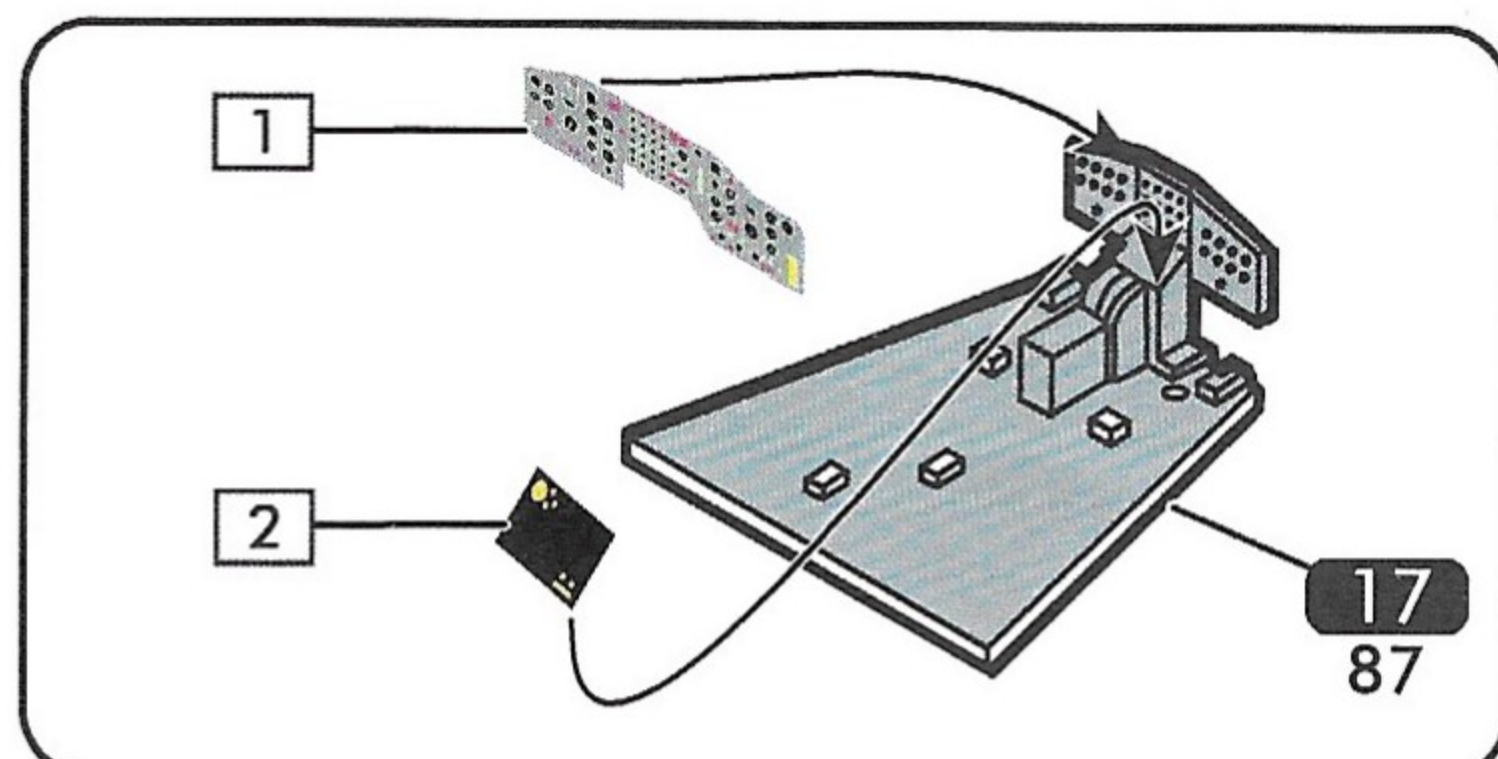
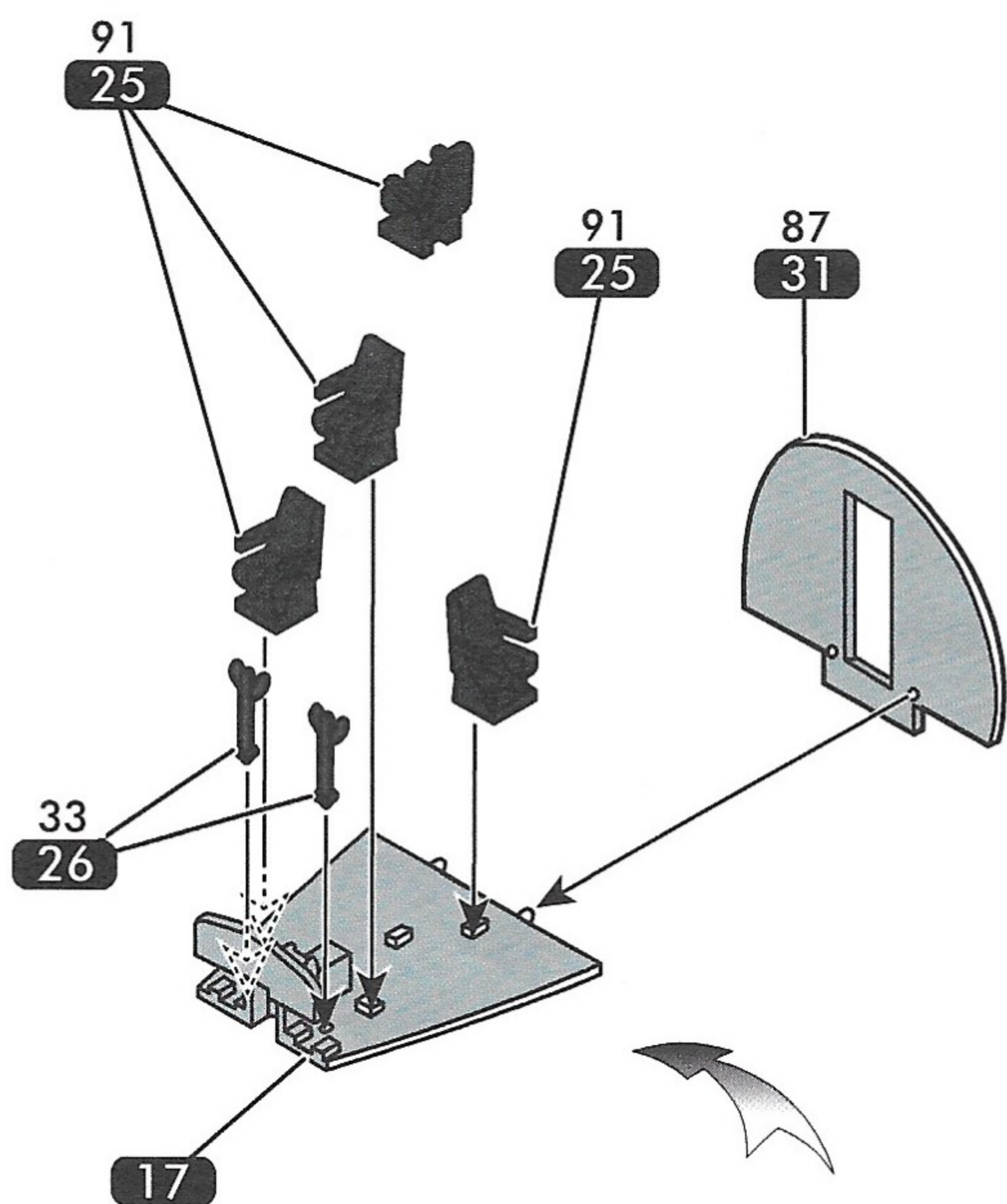
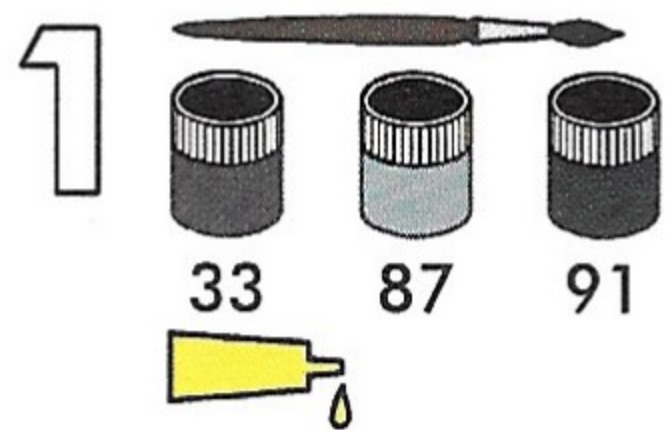

3

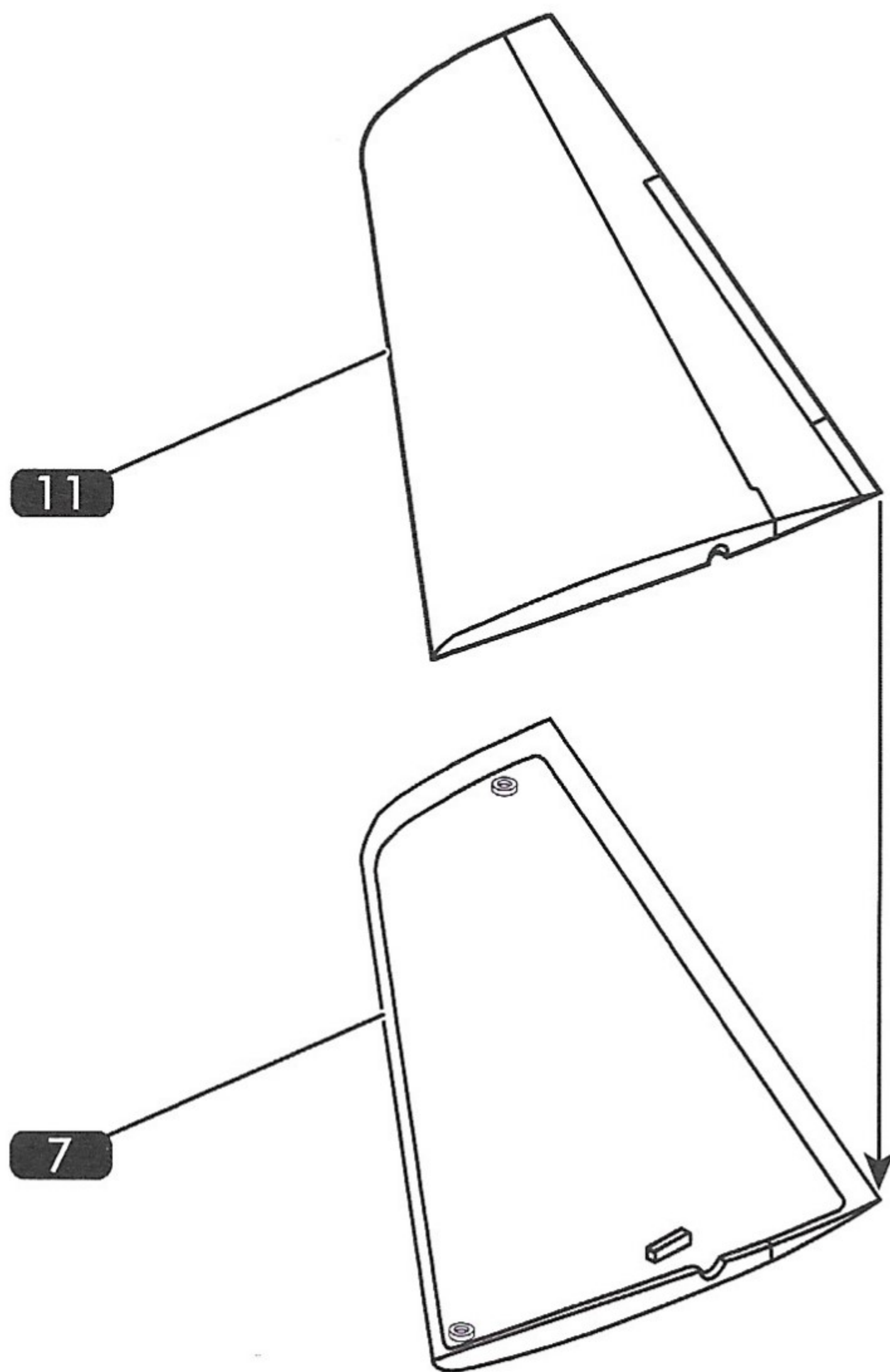

4

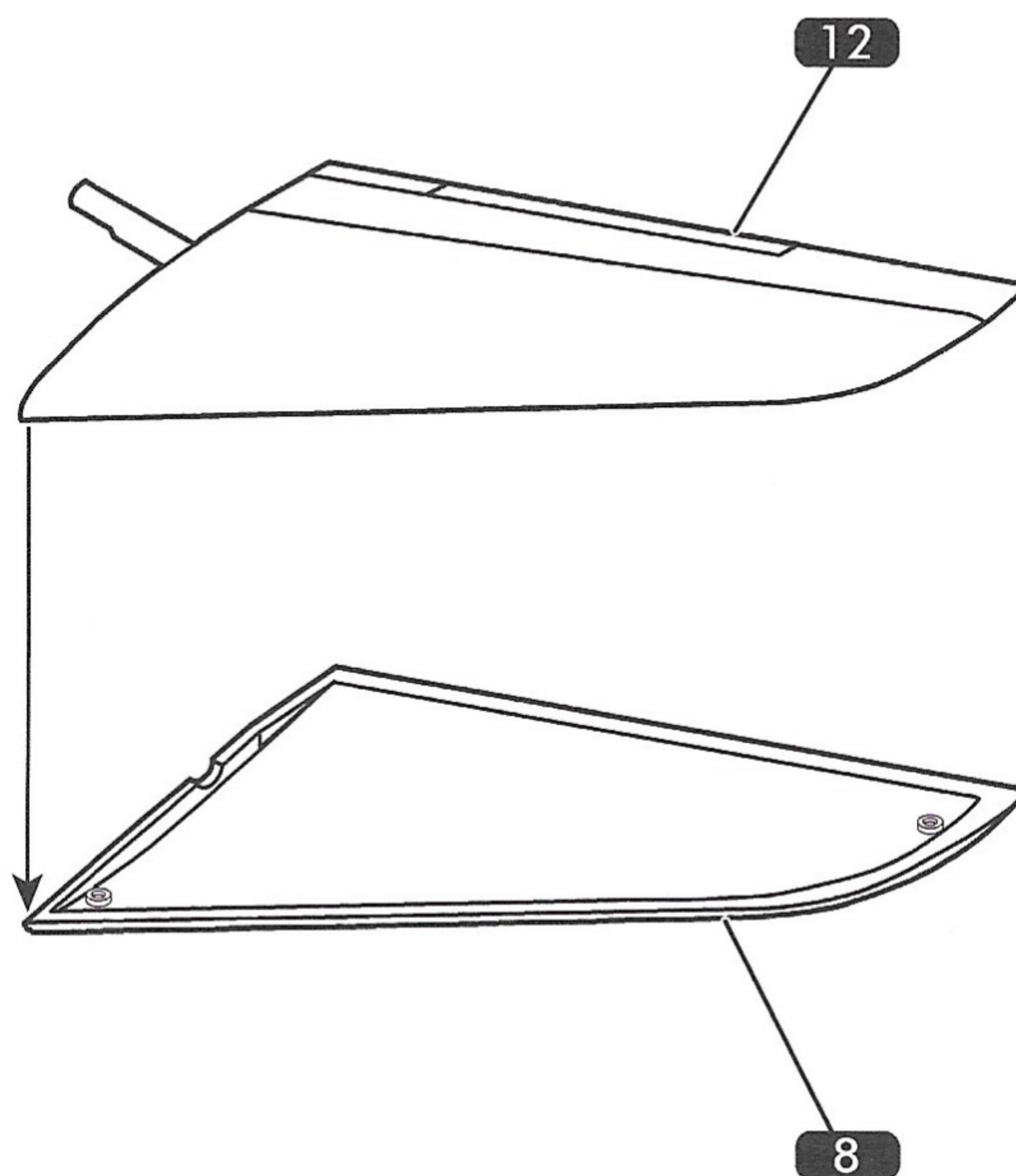

5

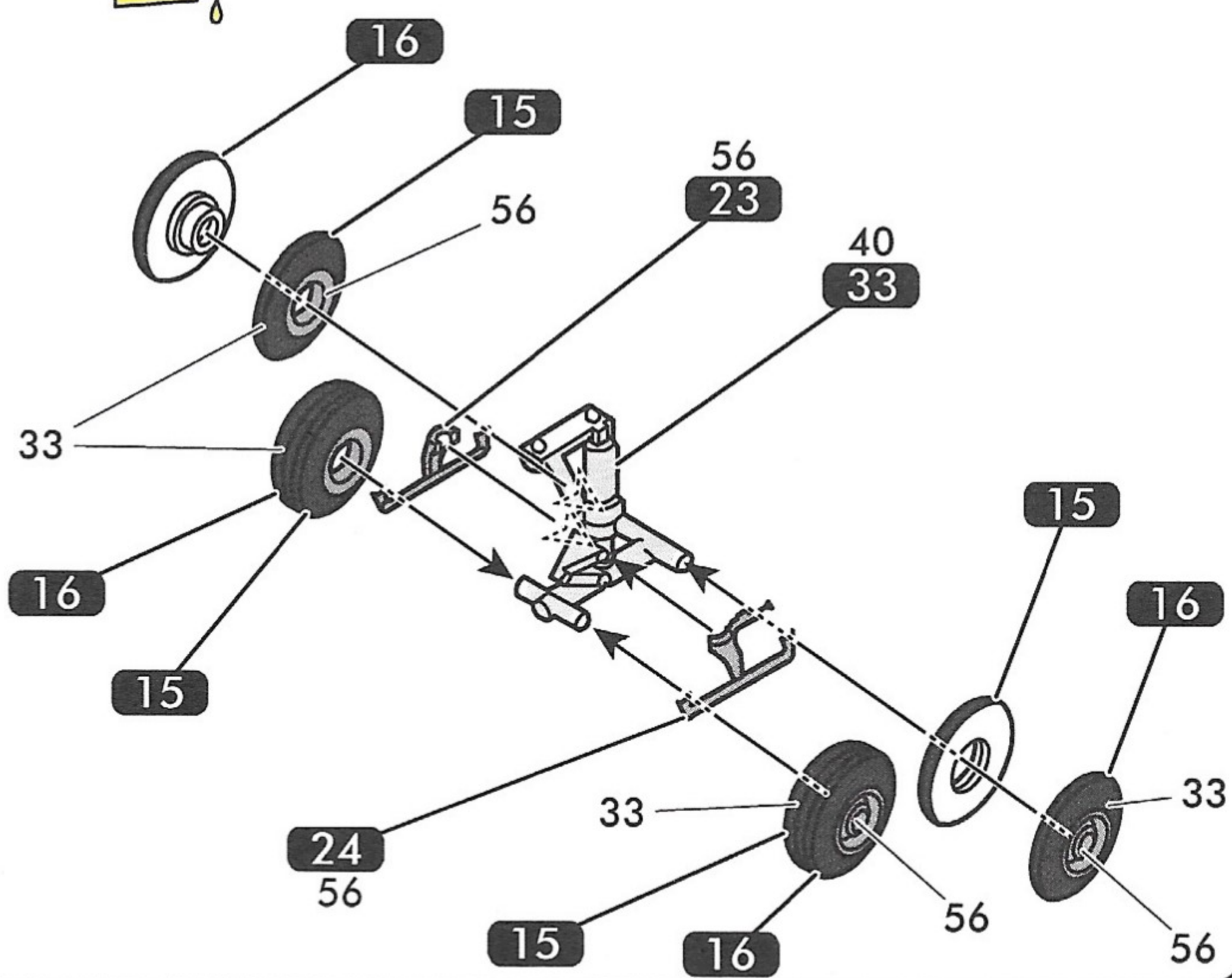
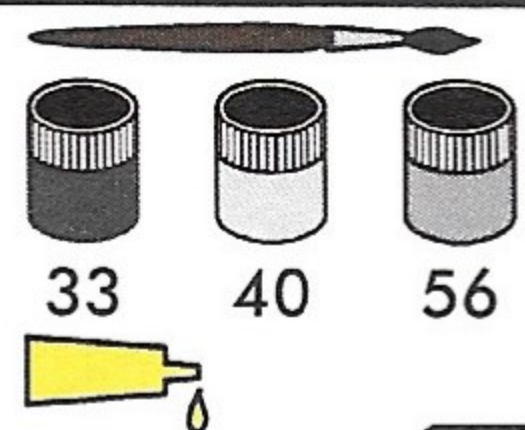

6

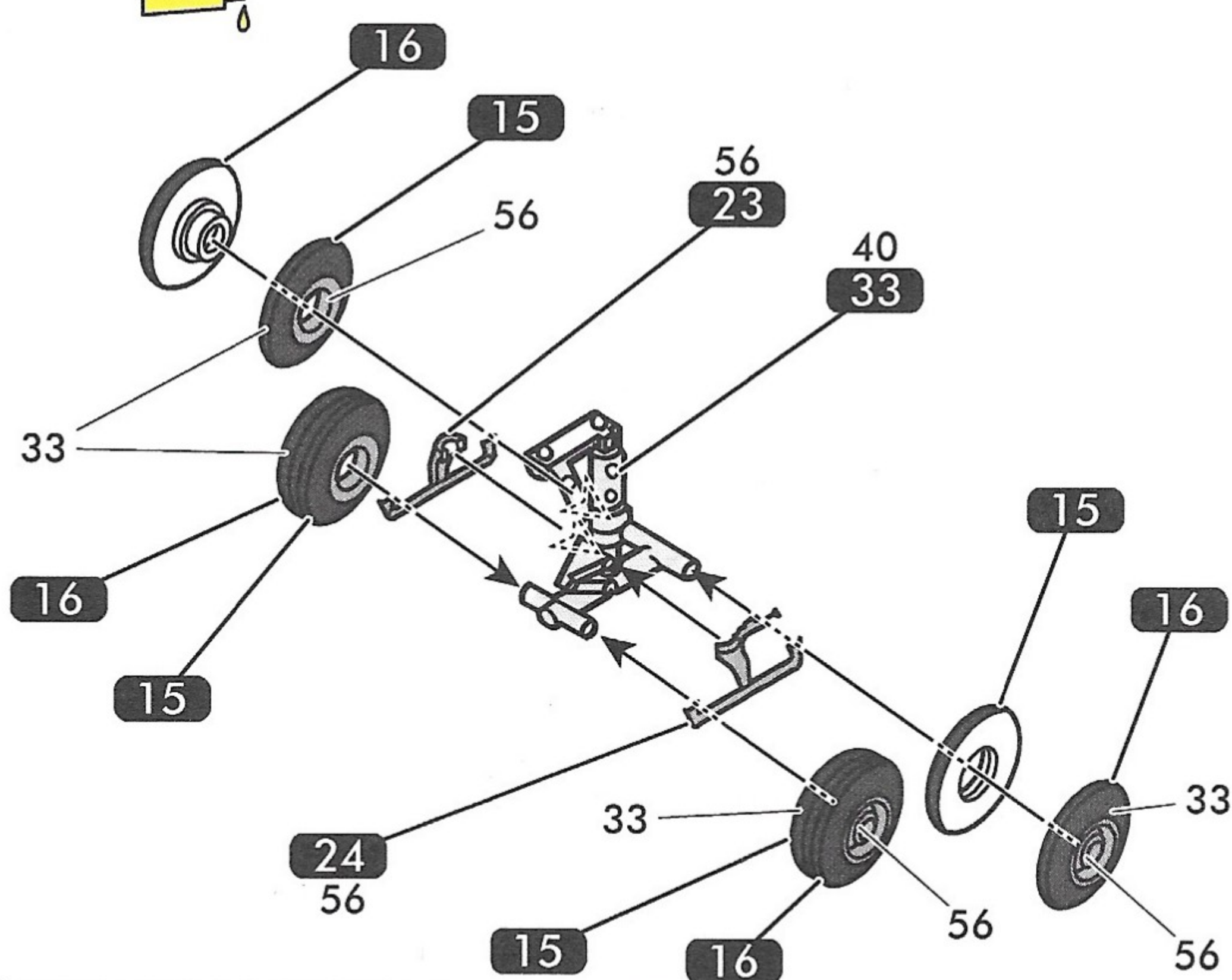
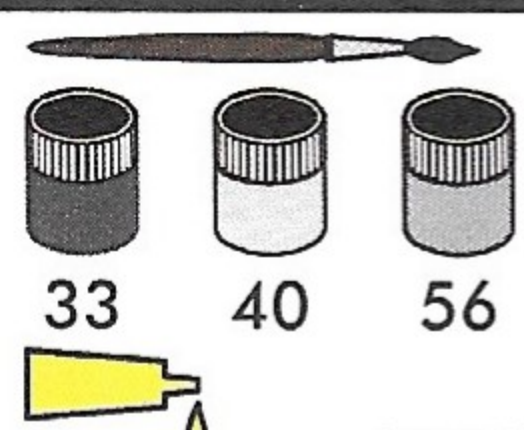

7

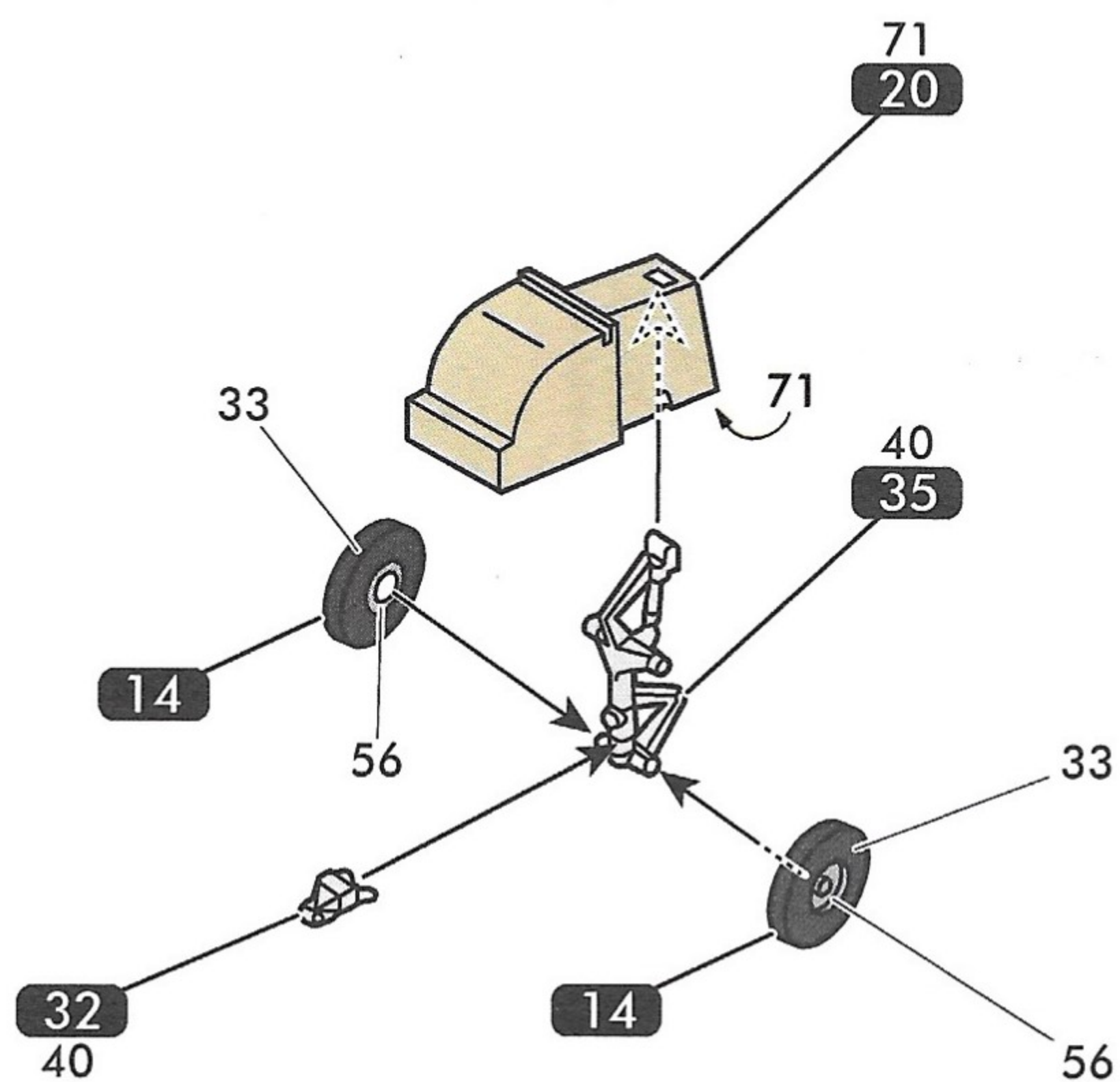
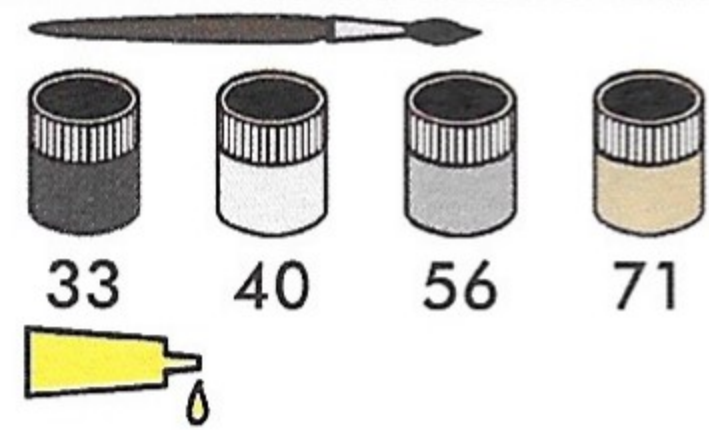

x4

8

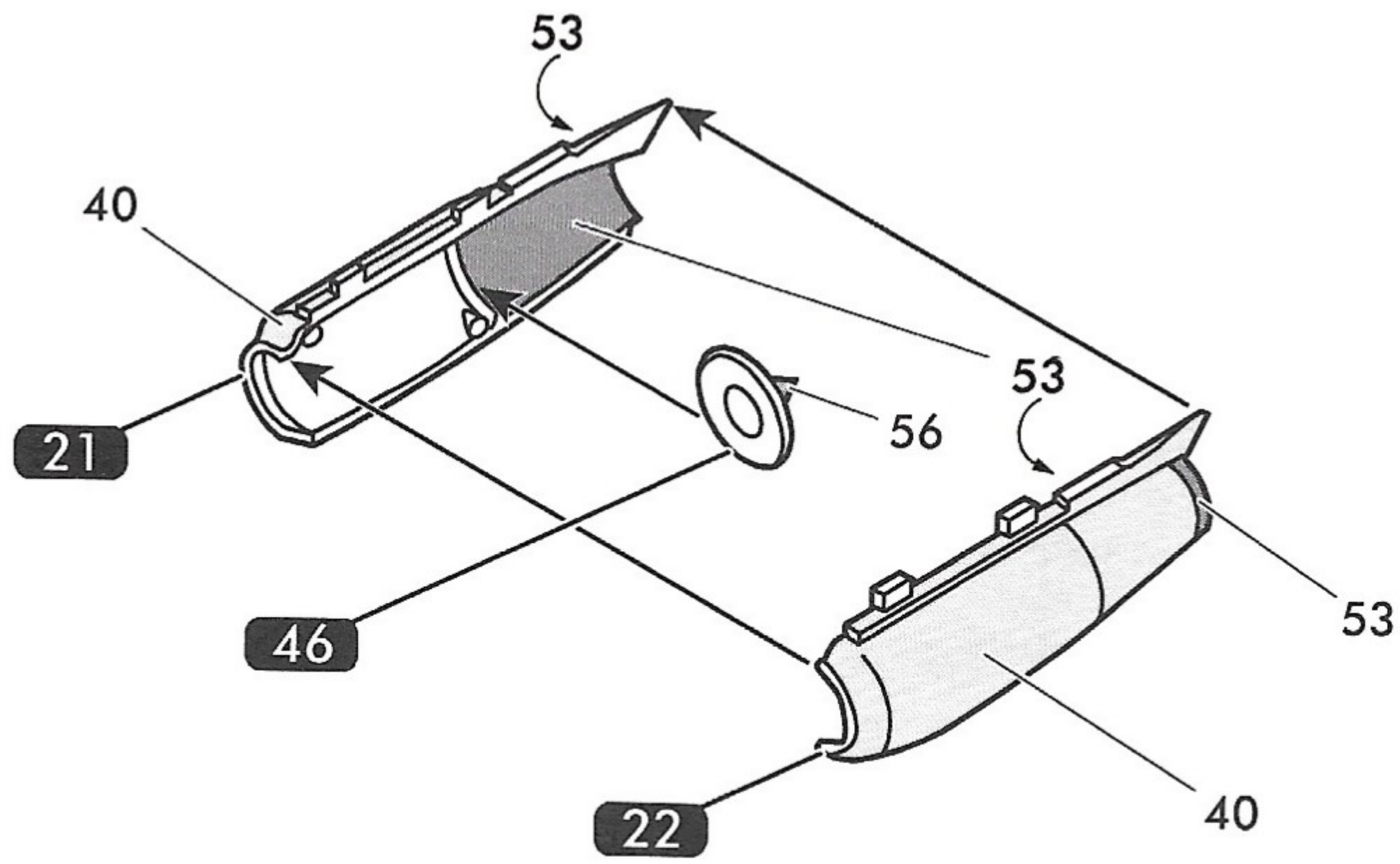
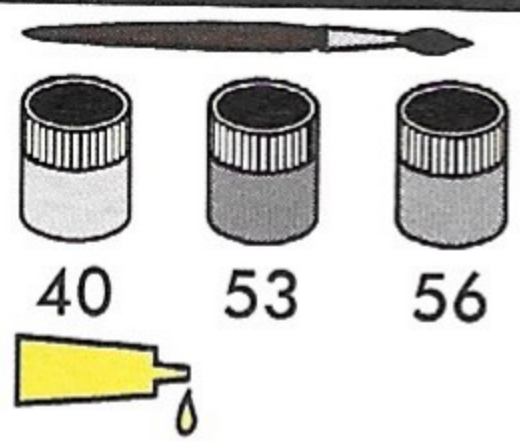

9

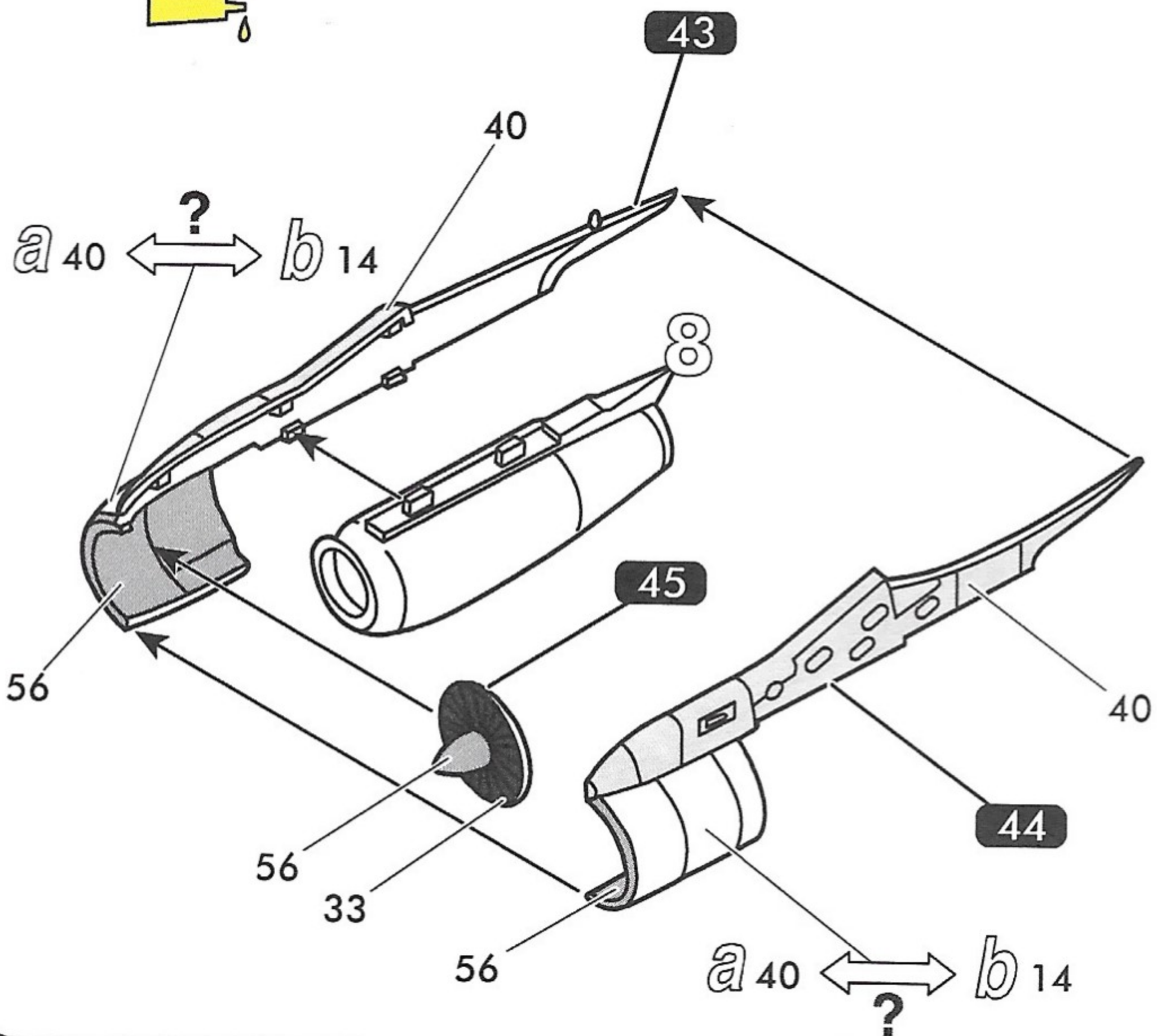
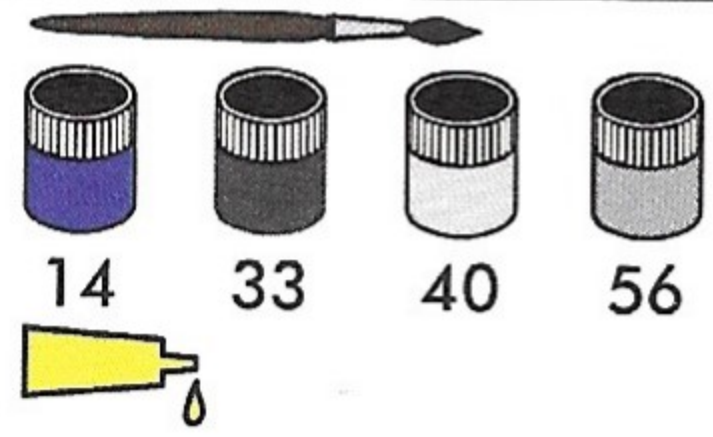

10

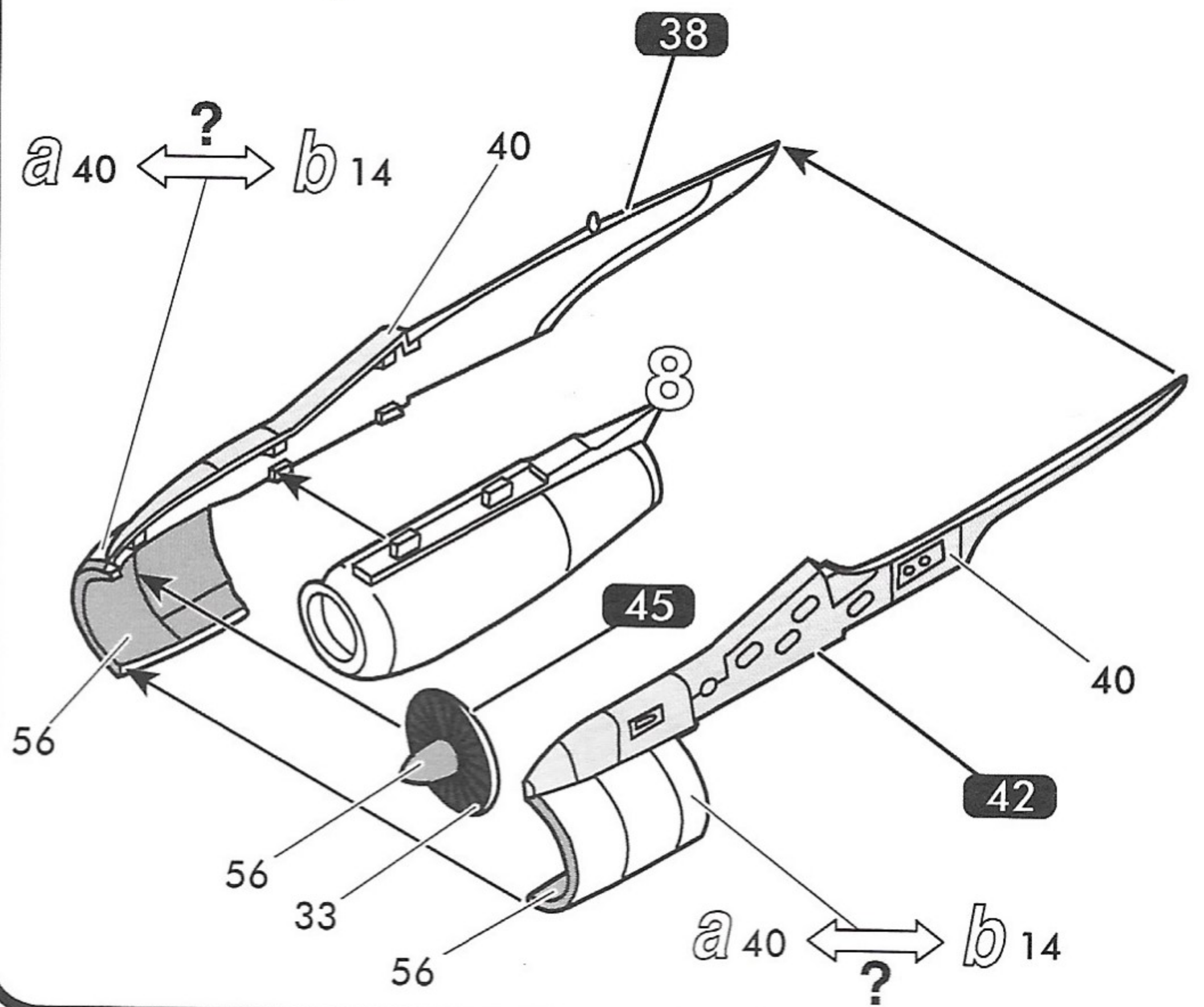
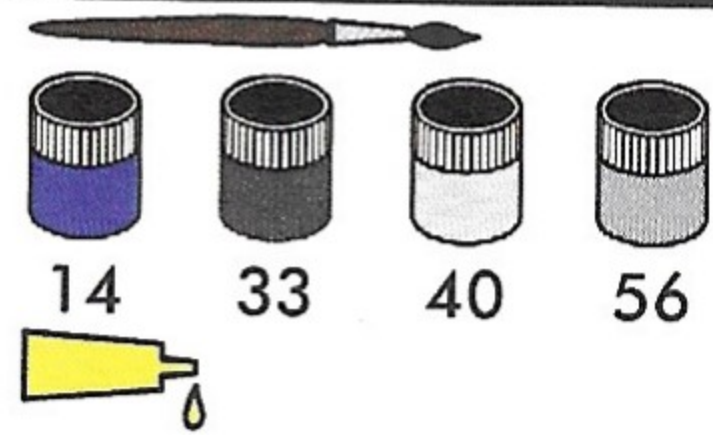

11

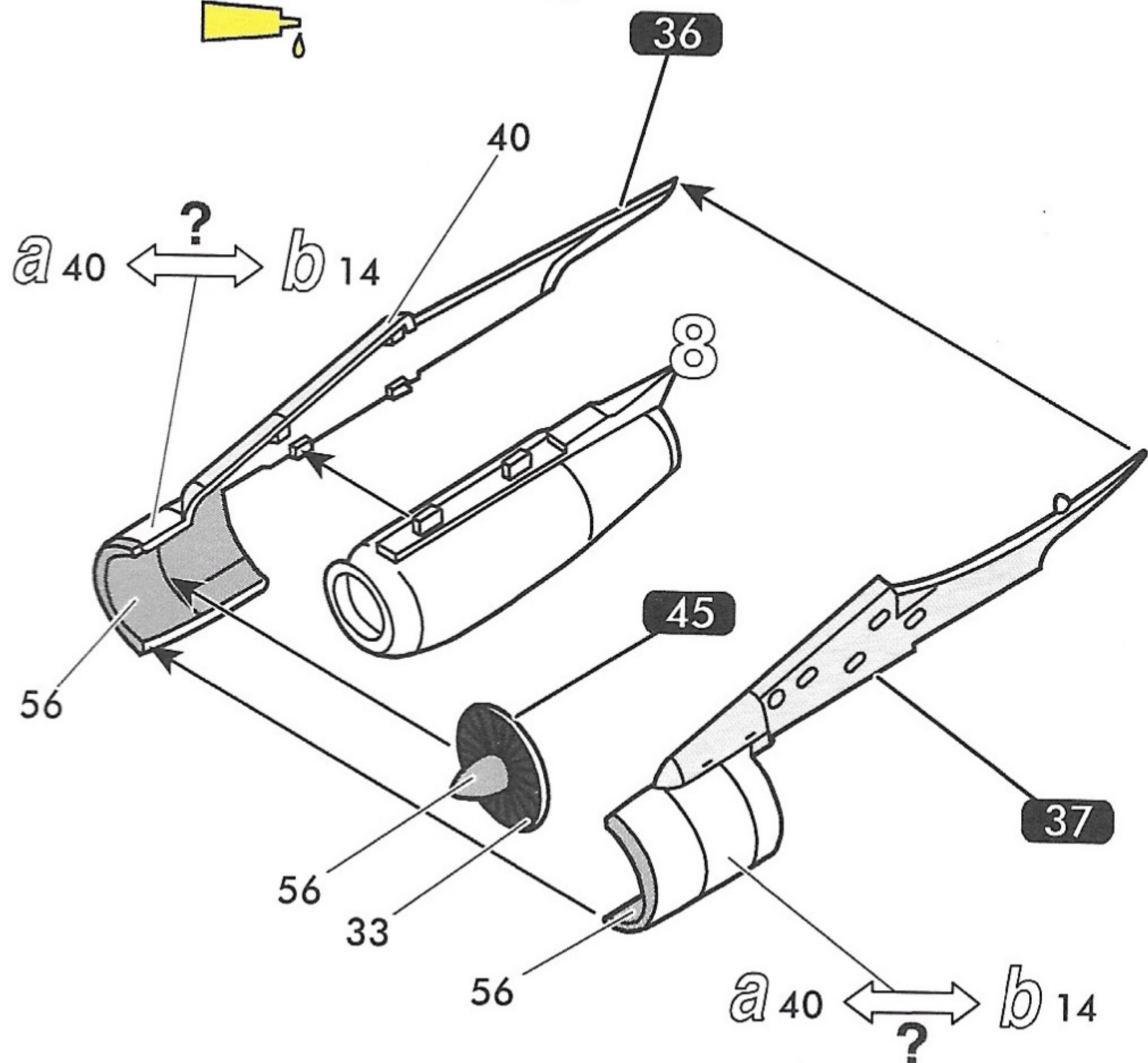
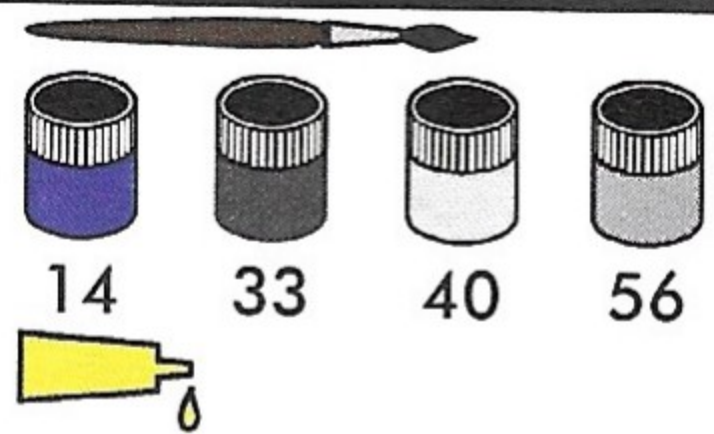

12

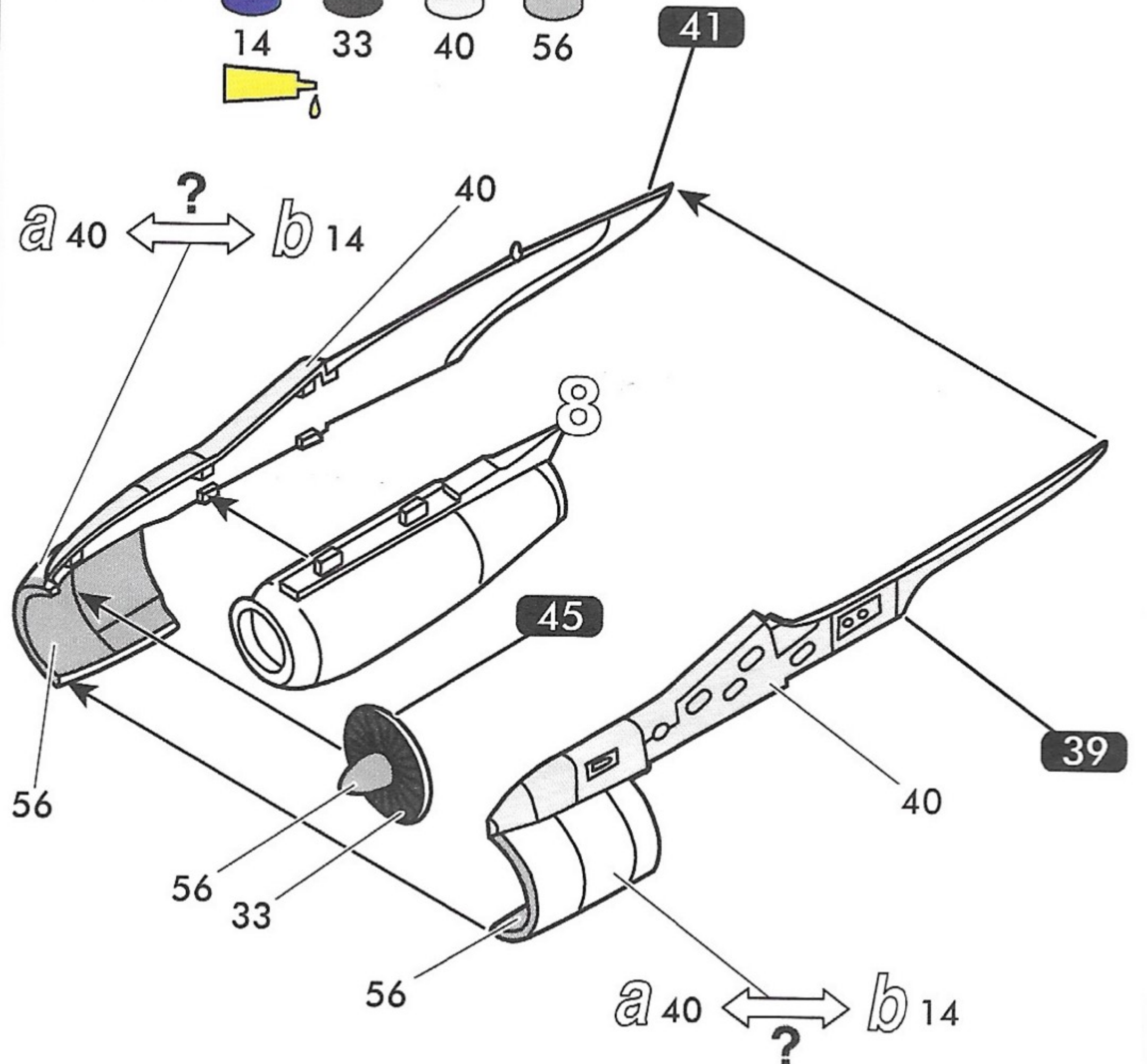
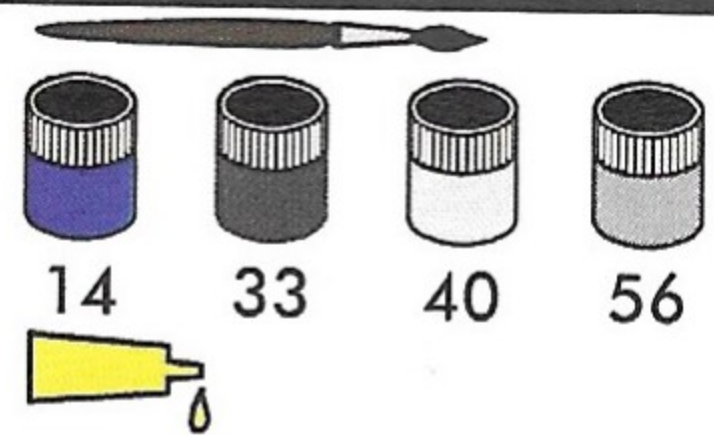

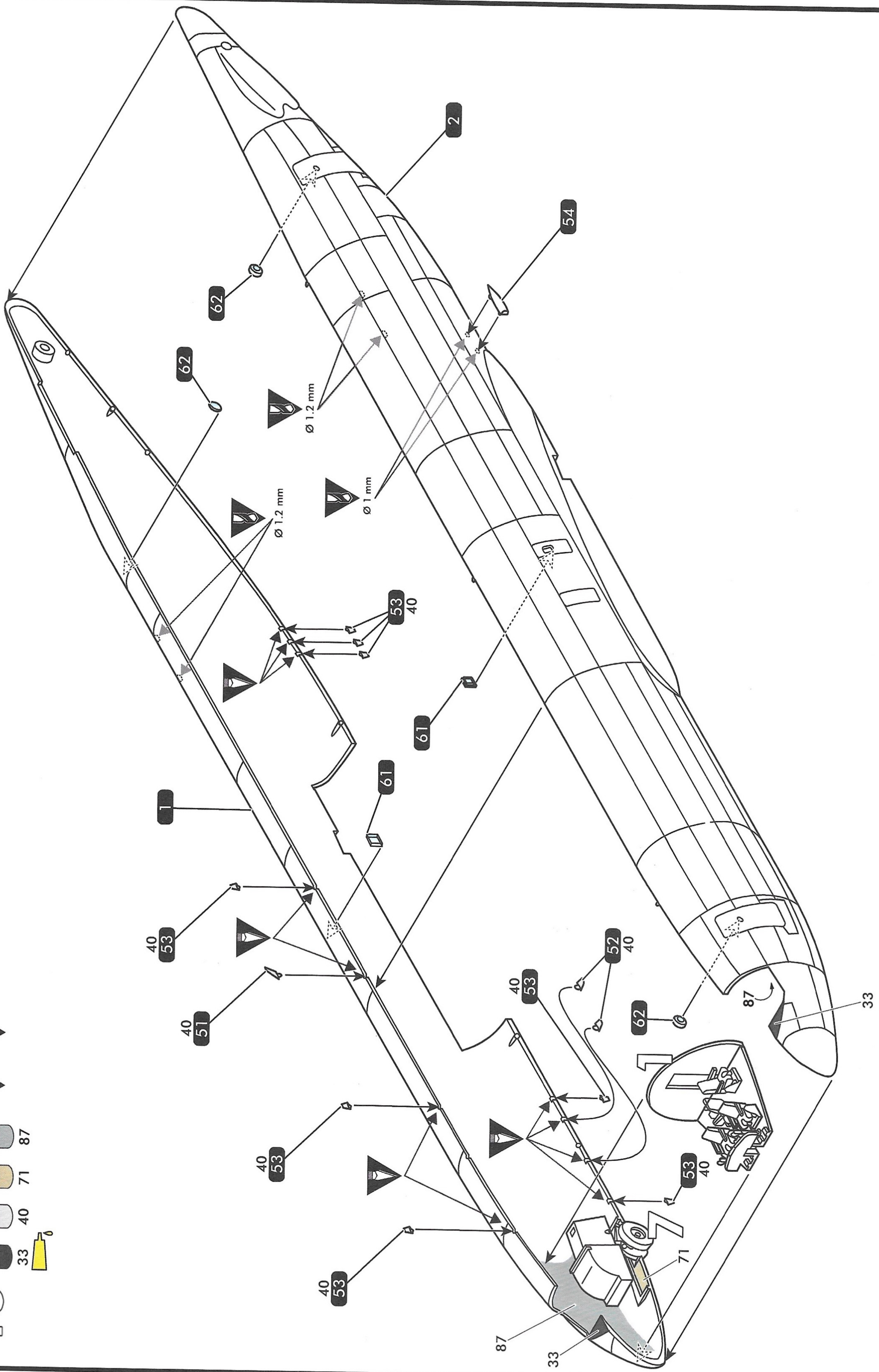
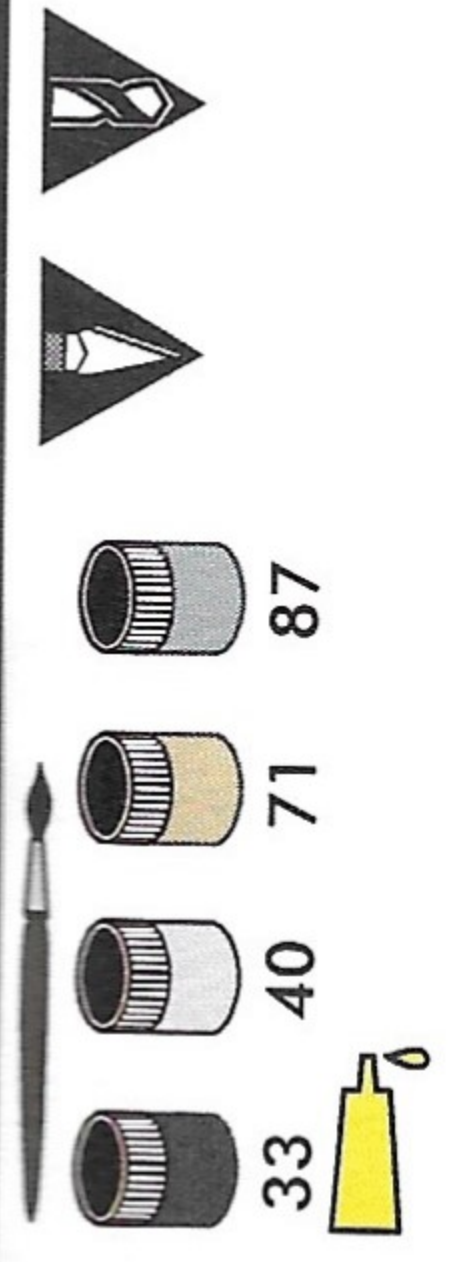

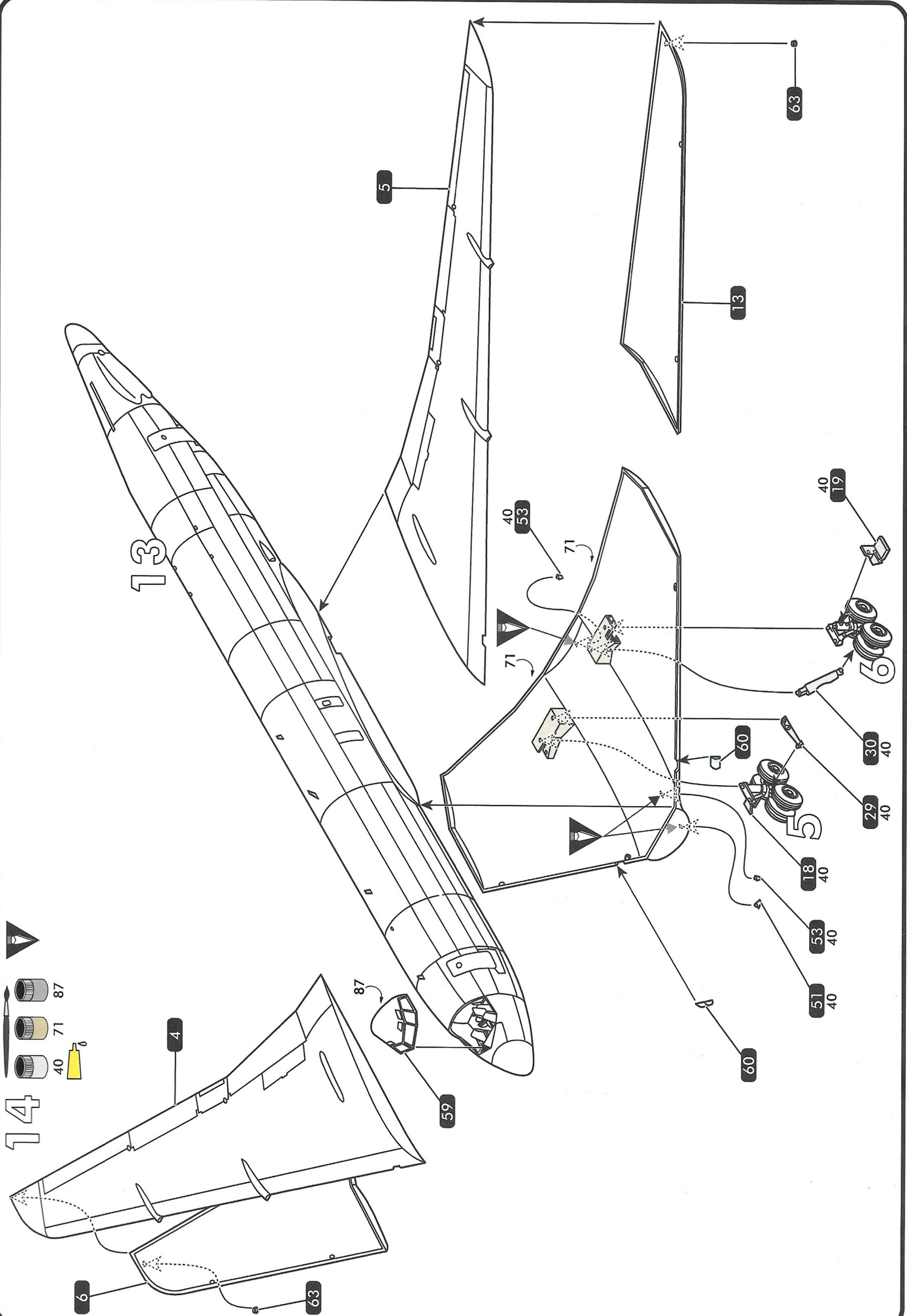



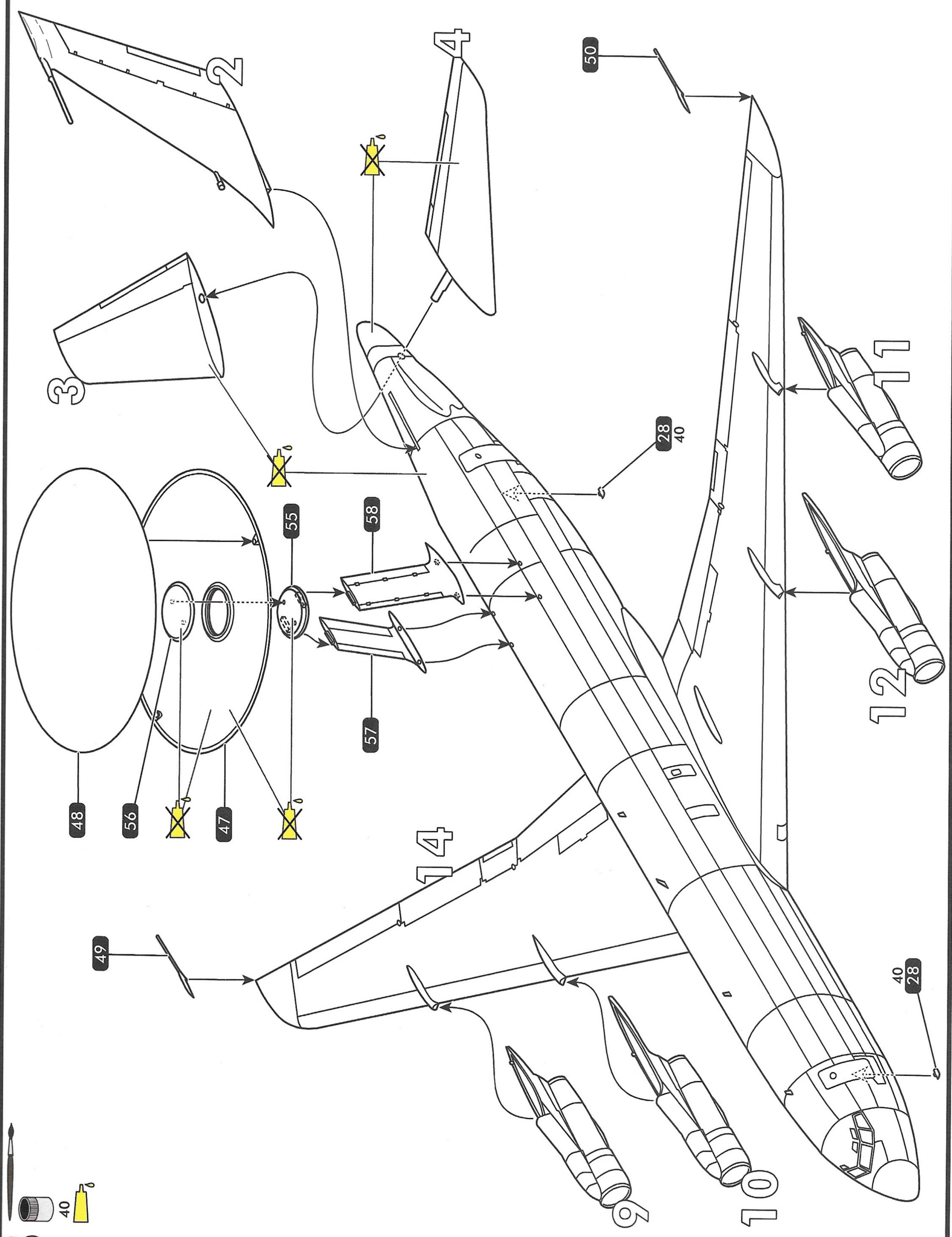
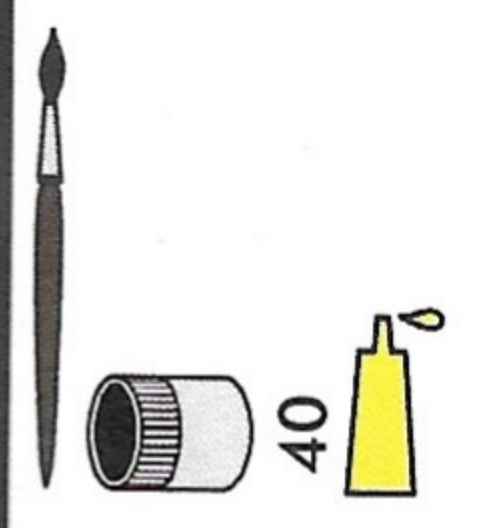



15







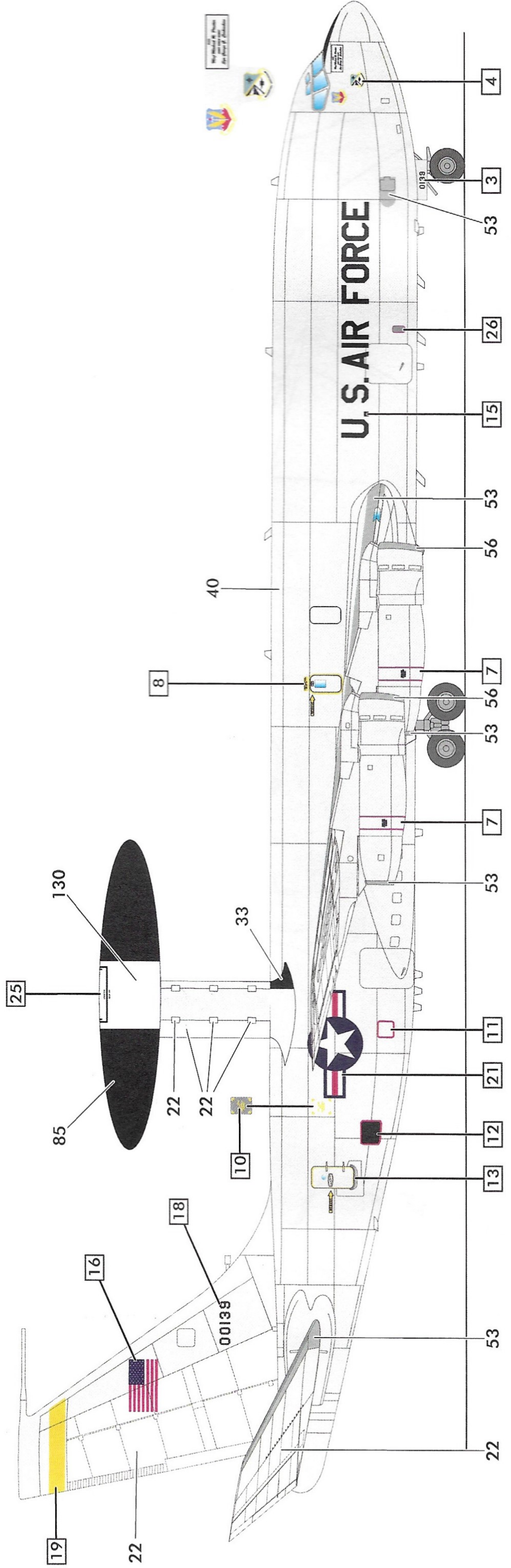
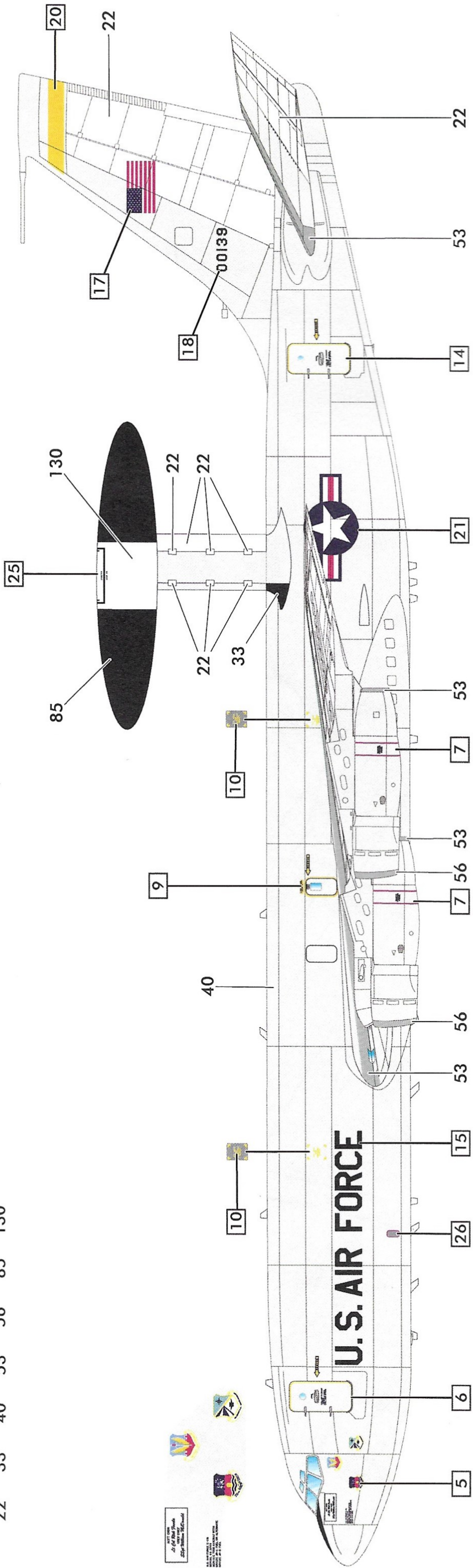

**BOEING E-3C AWACS Pnr22831, Sr 80-00139,
965th Airborne Warning and Control Squadron, Tinker AFB, Oklahoma, 1990**

-  22
-  33
-  40
-  53
-  56
-  85
-  130



16



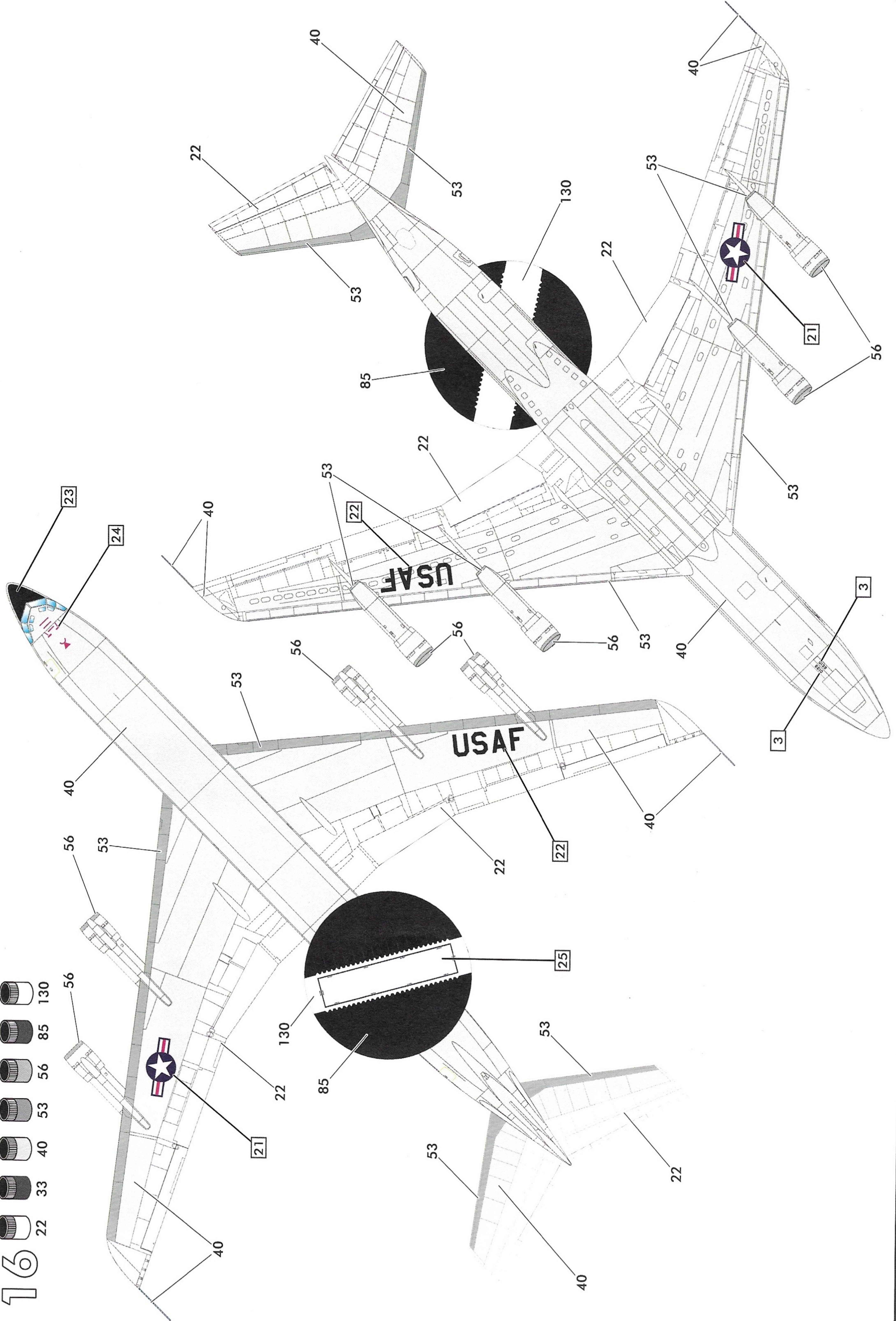

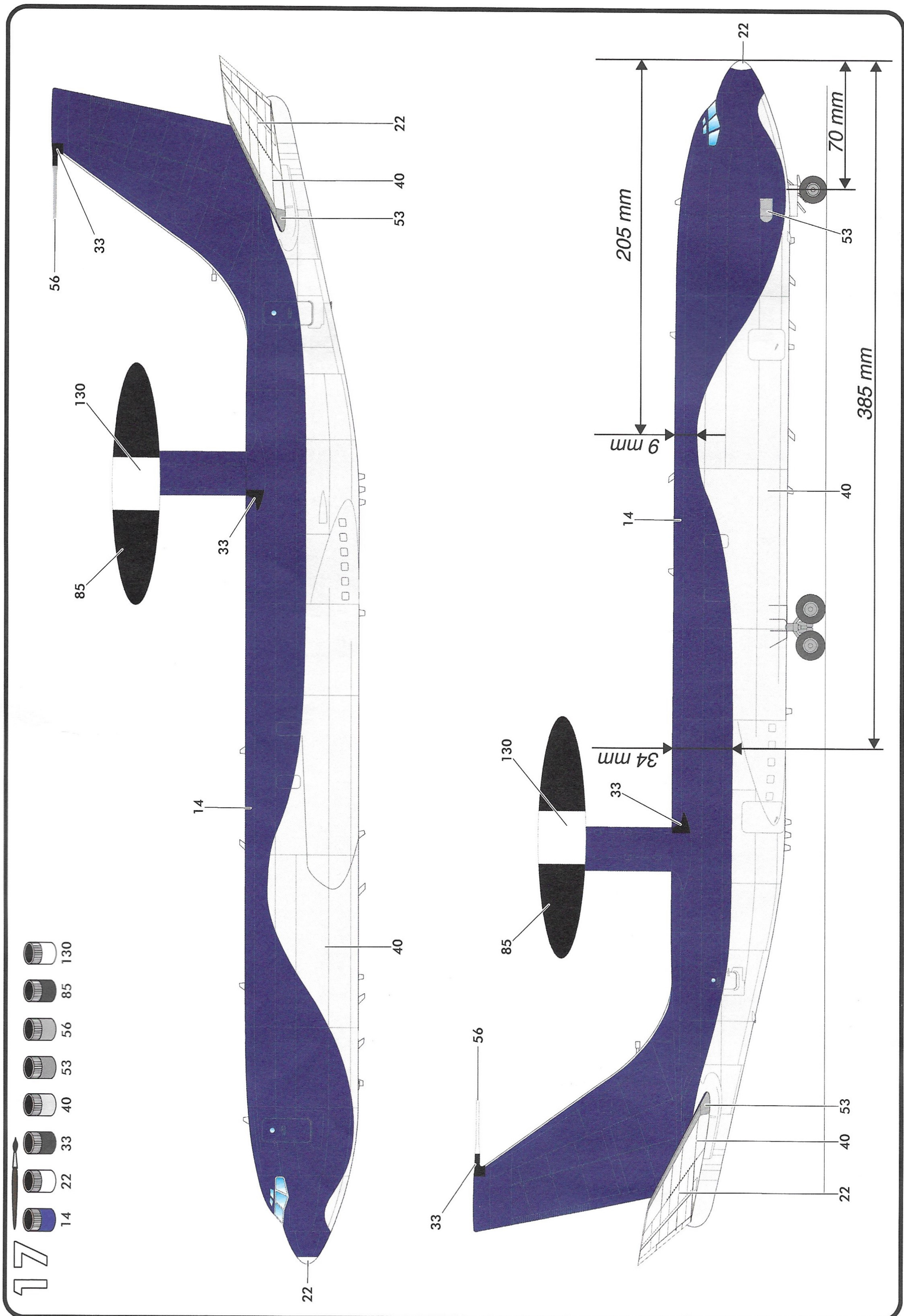

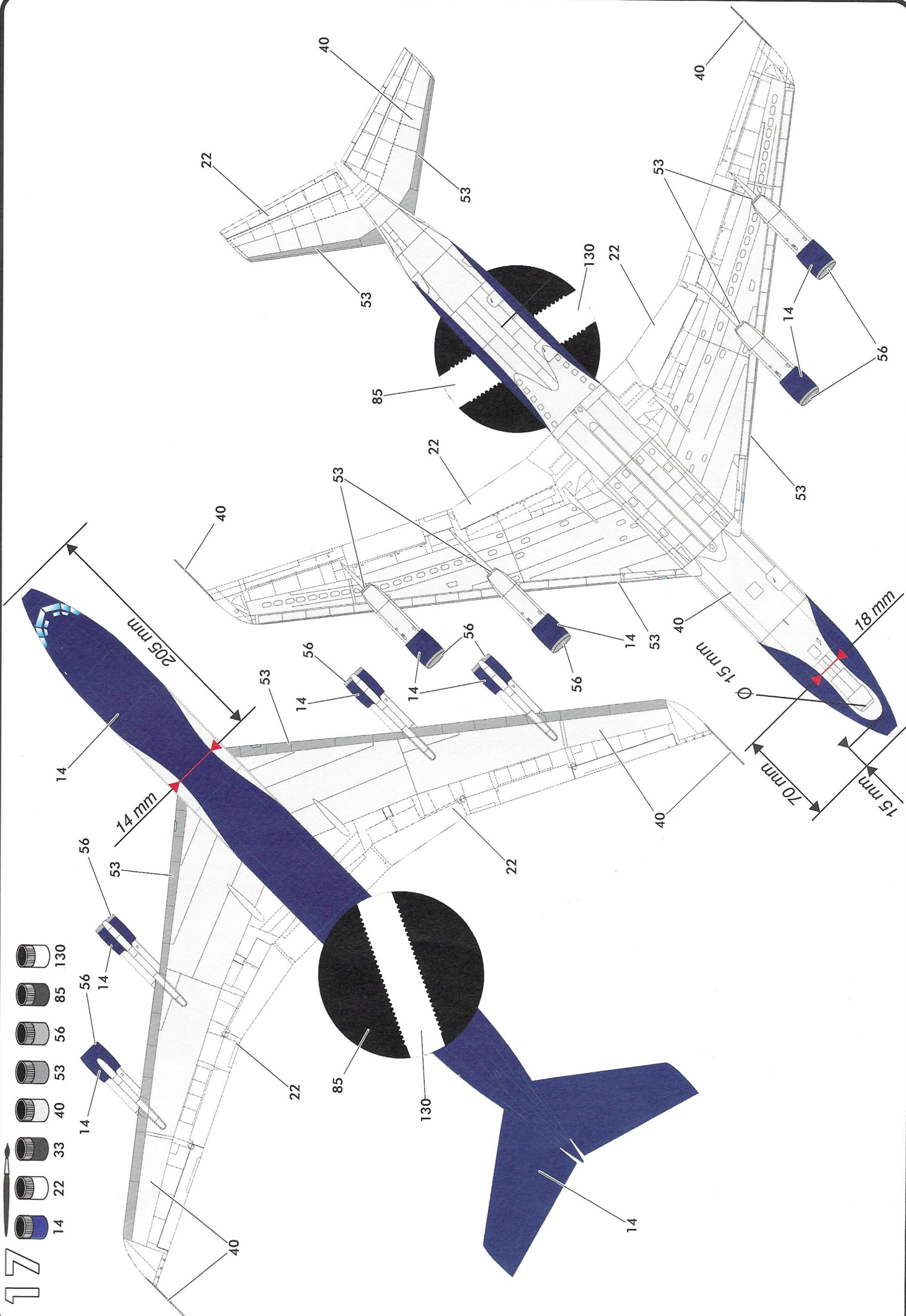

-  22
-  33
-  40
-  53
-  56
-  85
-  130











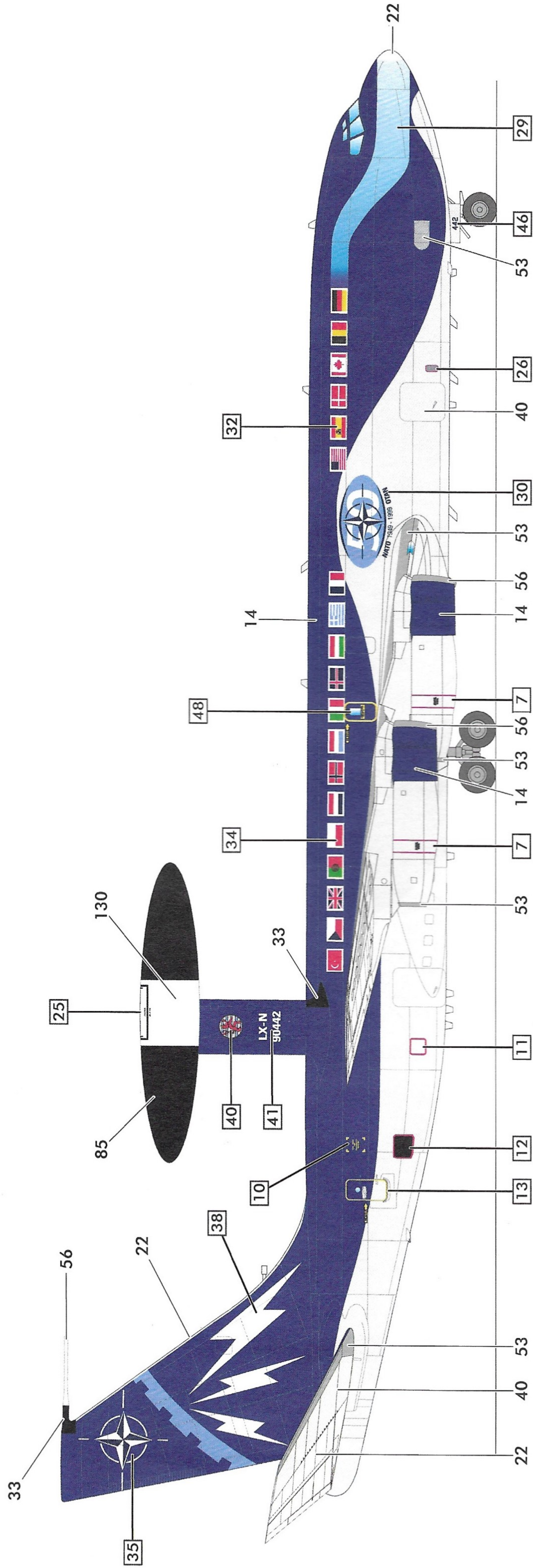
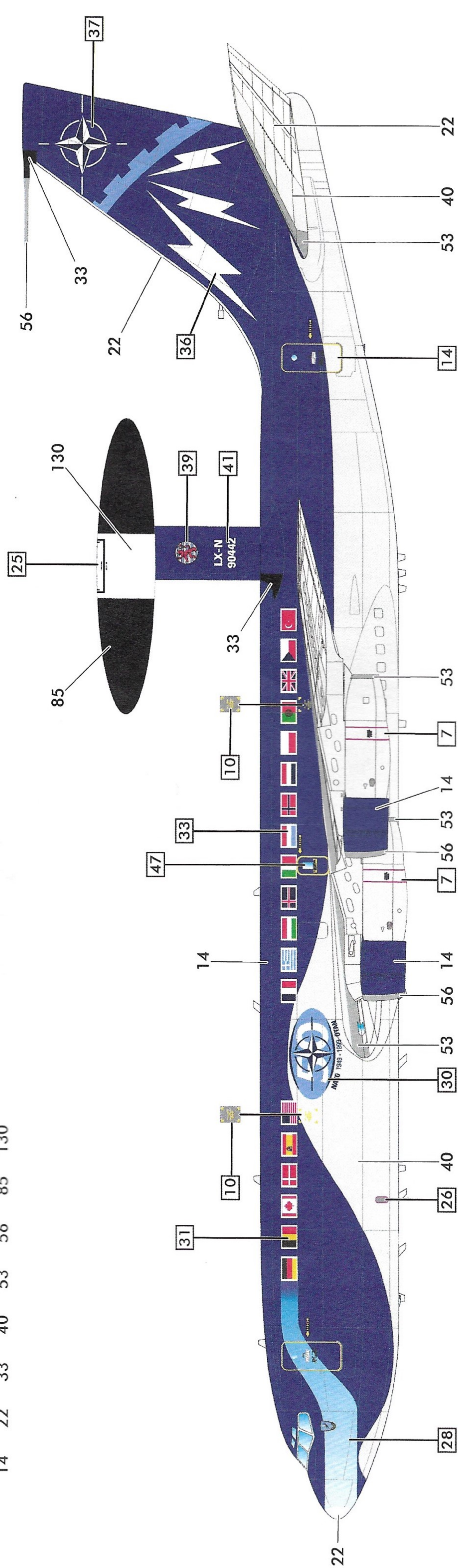



BOEING E-3A AWACS Pnr22855, LX-N90442, NAEW&CF (NATO Airborne Early Warning & Control Force), 50th Anniversary Livery, Geilenkirchen NATO Air Base, Germany, 1999.

-  14
-  22
-  33
-  40
-  53
-  56
-  85
-  130



-  14
-  22
-  33
-  40
-  53
-  56
-  85
-  130

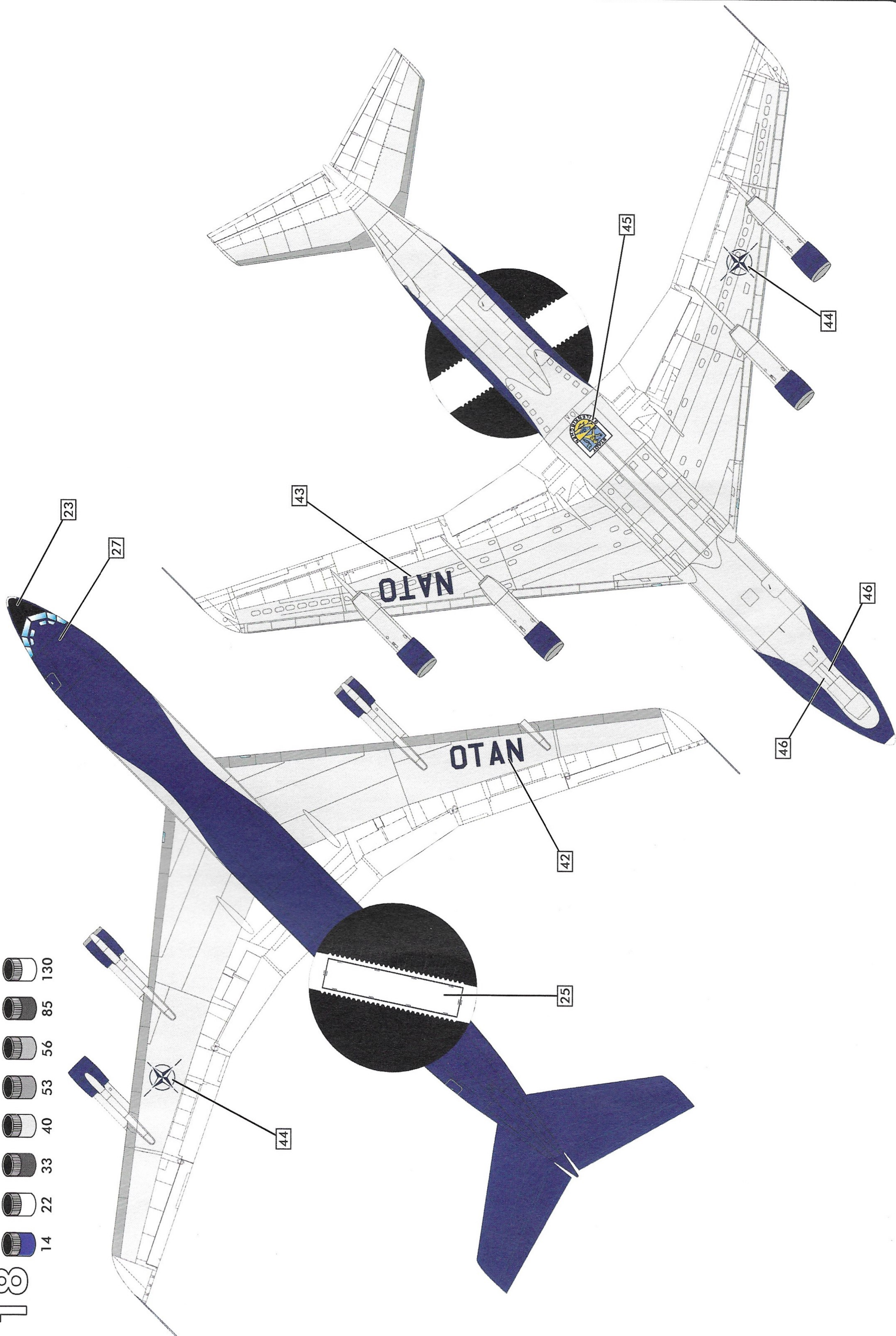

SERVICE CONSOMMATEURS 

www.heller.fr

Pour toute demande de SAV, connectez-vous sur notre site
www.heller.fr puis envoyez votre demande détaillée via
l'onglet «NOUS CONTACTER»

For any request of SAV (after-sale service), please connect on
our website www.heller.fr then send us your detailed request
via the «NOUS CONTACTER» tab.

MAPED HELLER JOUSTRA SAS

Chemin de la Porte

61160 - TRUN

FRANCE



Fabriqué en France