

# MIL MI-24 HIND GUNSHIP

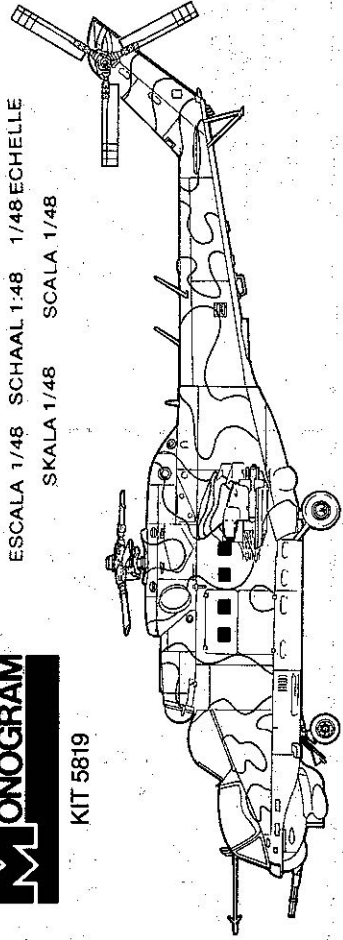

KIT 5819

1/48 SCALE MASSTAB 1:48  
 ESCALA 1/48 SCHAAL 1:48 1/48 ECHELLE  
 SKALA 1/48 SCALA 1/48



MONOGRAM MODELS, INC. Morton Grove, Ill. Copyright © 1987. All rights reserved. Made in U.S.A. 5819-0200

One of the deadliest weapons in the skies today is the attack helicopter, the most formidable of these being the Soviet Mil Mi-24 Hind. This weapon is seen in two major variations, the Hind A, with an angular cockpit greenhouse, and the Hind D, with a unique double-bubble arrangement for the two pilots. Both versions are equipped to carry up to eight fully armed troops plus heavy loads of weapons and support equipment, a characteristic unique to the Hind.

The Hind D version, depicted by this Monogram model, is specifically designed for the ground attack role, and carries a nose-mounted 12.7mm four barrel rotary cannon. Additional guns can be mounted on the stubby wings, along with a variety of the ground attack missiles and bombs. Two of these helicopters were delivered to the West by defectors in 1986.

Production of this deadly machine began over ten years ago and several hundred have been exported to countries outside the Warsaw Pact. Most notable have been the Hinds used by the Soviet-backed puppet government in Afghanistan and those now fighting with the Sandinistas in Nicaragua, about 300 miles south of Mexico.

The Mi-24 is fast, having a top speed of nearly 200 mph, due to a pair of stubby wings which provide nearly 25% of the lift at cruise. This also makes the Hind quite maneuverable, but it has a combat range of only 99 miles.

Your kit of the Hind D comes with markings for these helicopters used in Afghanistan, Czechoslovakia, Nicaragua and by the Soviet Union.



CEMENT TOGETHER  
 VERLEVEN  
 UNIR CON PEGAMENTO  
 LÄHMEN  
 A COLLER  
 LIMMAS  
 INCOLLARE INSIEME



DO NOT CEMENT  
 NICHT ALEBEN  
 NE PAS COLLER  
 NE PAS COLLER  
 LIMMAS NITE  
 NON INCOLLARE



OPTIONAL PARTS  
 ALTERNATIVE  
 KEZES-ONDELELLEN  
 PIECES EN OPTION  
 VALFRIA DELAR  
 PARTI FACULTATIVE



REMOVE AND THROW AWAY  
 ENTFERNEN (ABFALL)  
 QUITE Y TIRE  
 VERWILDEREN EN WEGDOEIEN  
 A RETIRER ET JETER  
 ANJAGNENS OCH MANULERS  
 RIBBUDOT ELMINKA



REPEAT SEVERAL TIMES  
 ARBEJTSBANG MEHRMALS  
 REPTA VIOLAS VEZES  
 A REPEAT SEVERAL TIMES  
 ARBEJTSBANG MEHRMALS  
 REPTA VIOLAS VEZES



DECAL (ON IN WATER)  
 ABZEBILD  
 DECALCOMANIA (INQUE CON AGUA)  
 TRANSFERS (IN WATER DOPEN)  
 DECALCOMANIE (A PLOMBER DANS L'EAU)  
 DECAL (OPPAS I WATTEEN)  
 DECALCOMANIK (INNEERCI IN AGUON)

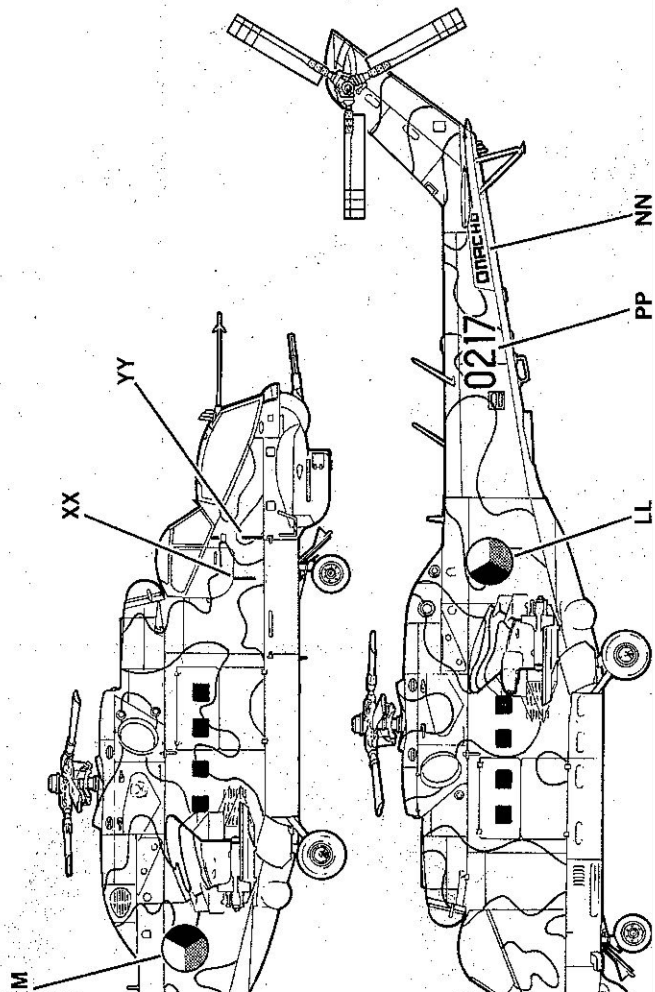
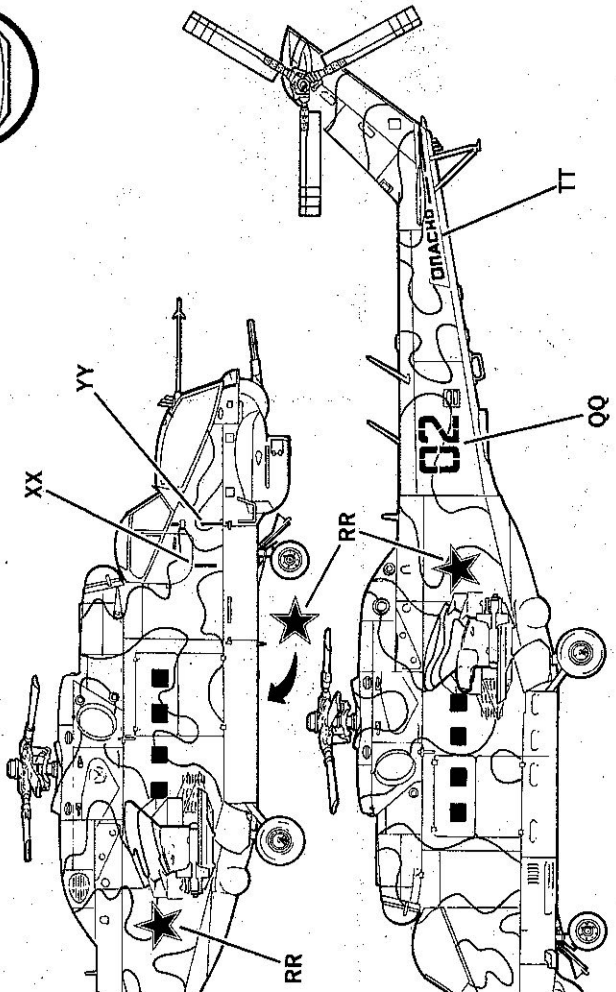

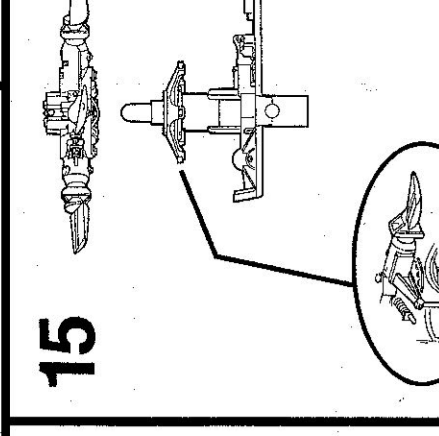
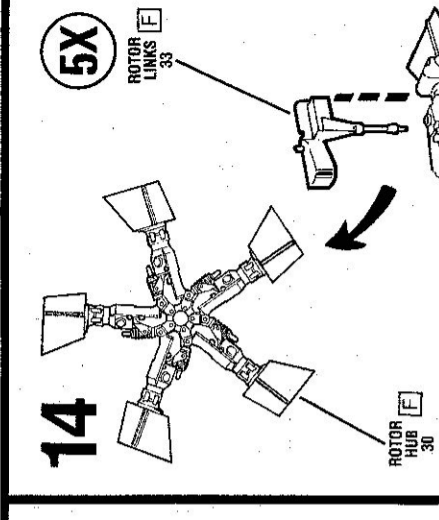
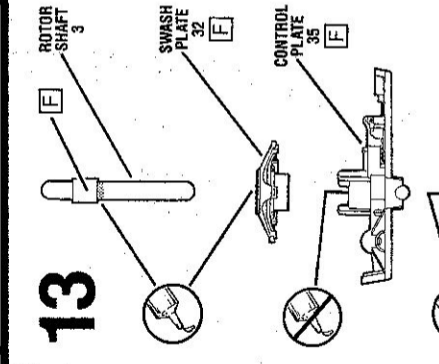
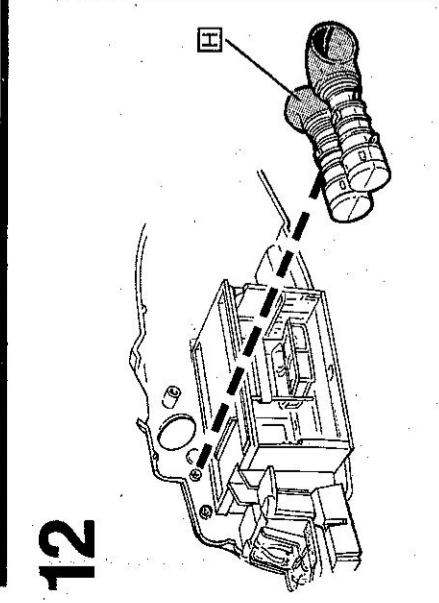
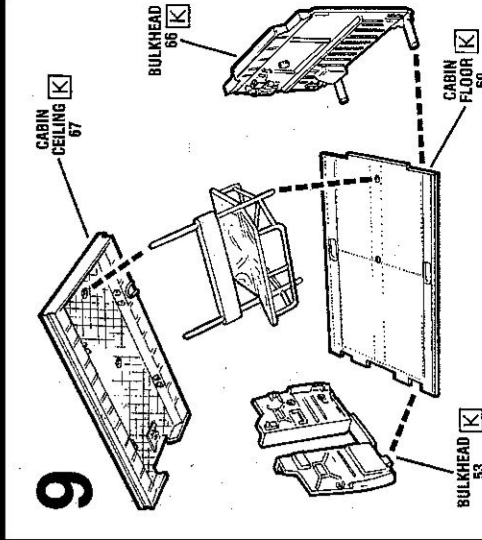
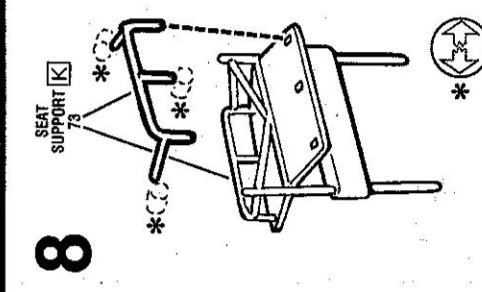
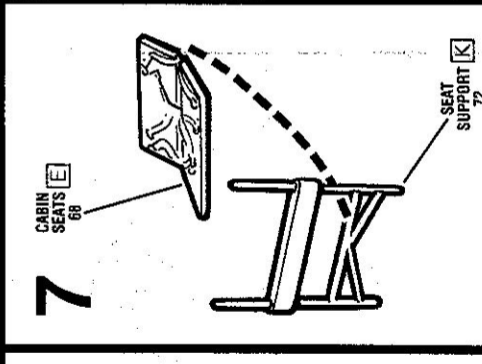
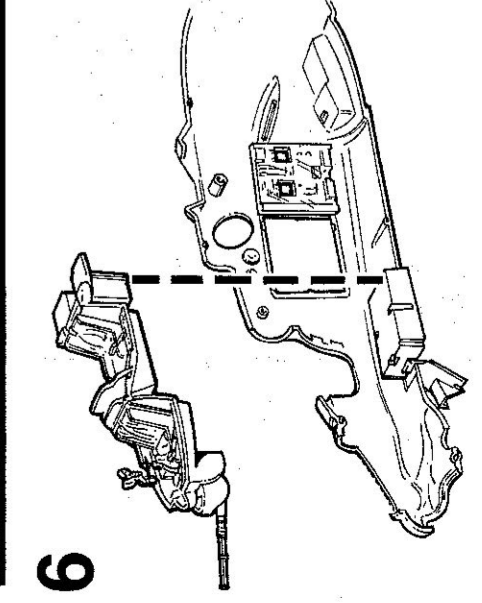
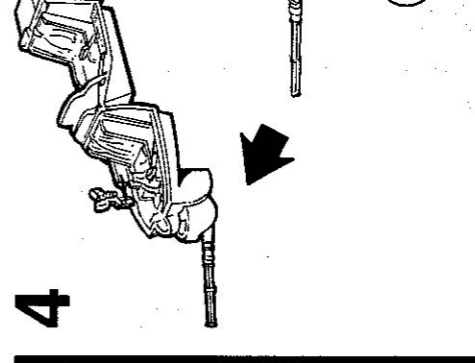
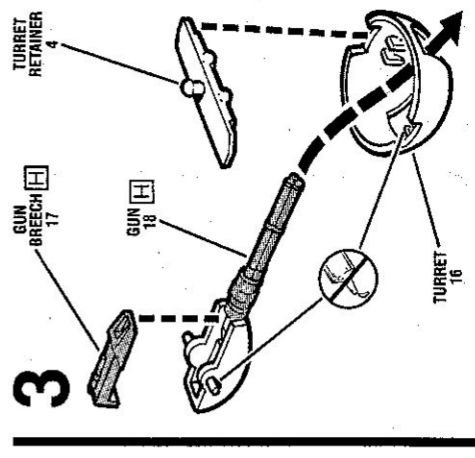
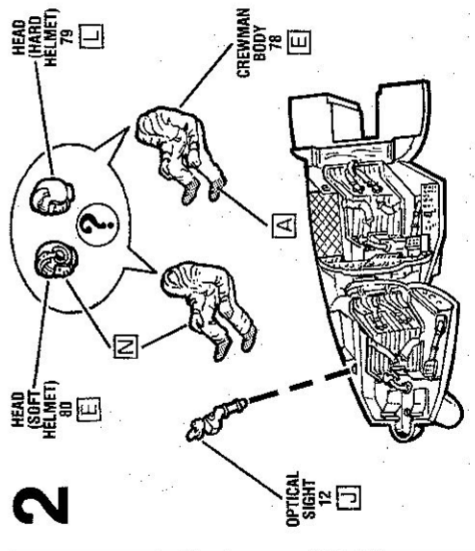
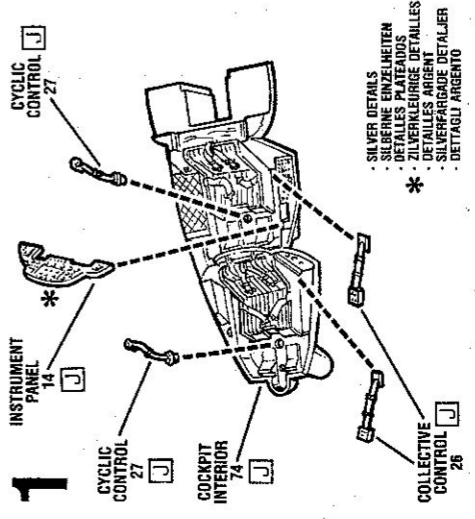

our kit.

NE
HARD
DURO
PIVARO
SCURO
INCO
TO
ICO
DURO

# 5

FUSELAGE  
HALF

CABIN  
WINDOWS  
104

NOSE  
GEAR  
WELL  
64

D

K

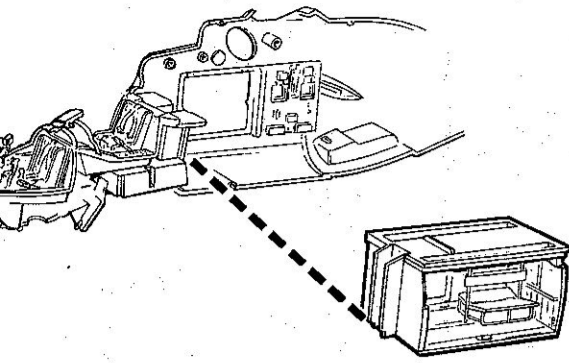
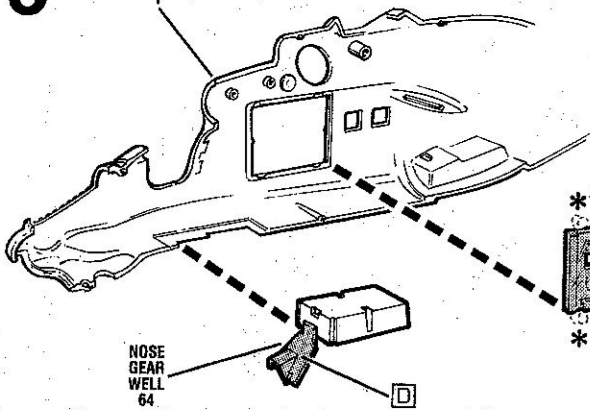
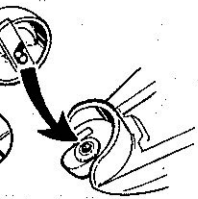

# 11

ENGINE  
HALF  
10

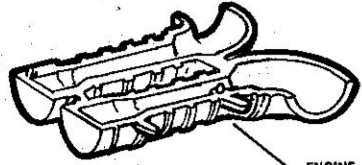
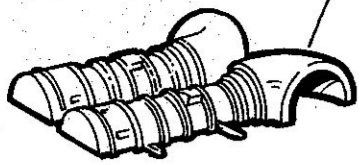

ENGINE  
HALF  
9

# 16

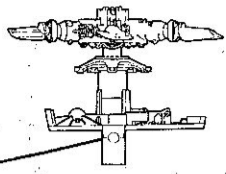

- PIN INTO HOLE
- ZAPPEN IN LOCH
- PERNO EN EL ORIFICIO
- PIN IN DE OPENING
- L'ERGOT S'EMBOÎTE DANS LE TROU
- SPRIJN I HĂL
- PERNO NEL FORD

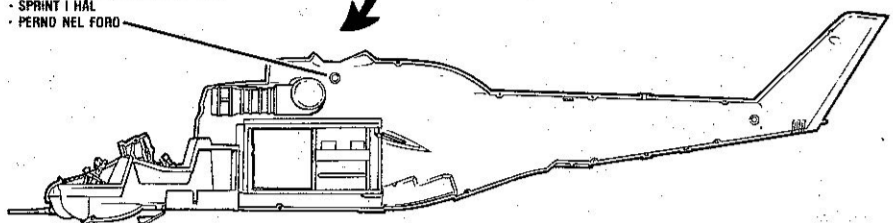

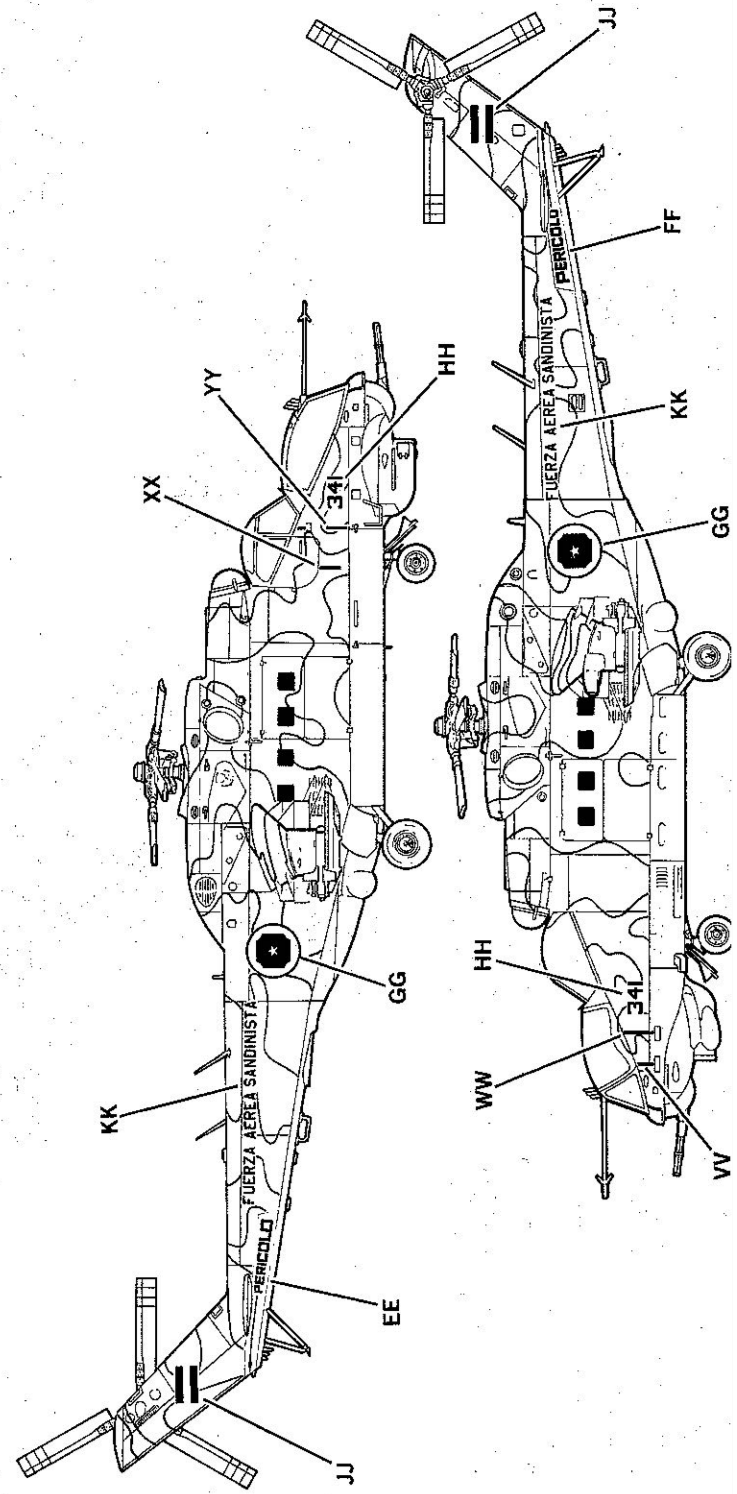
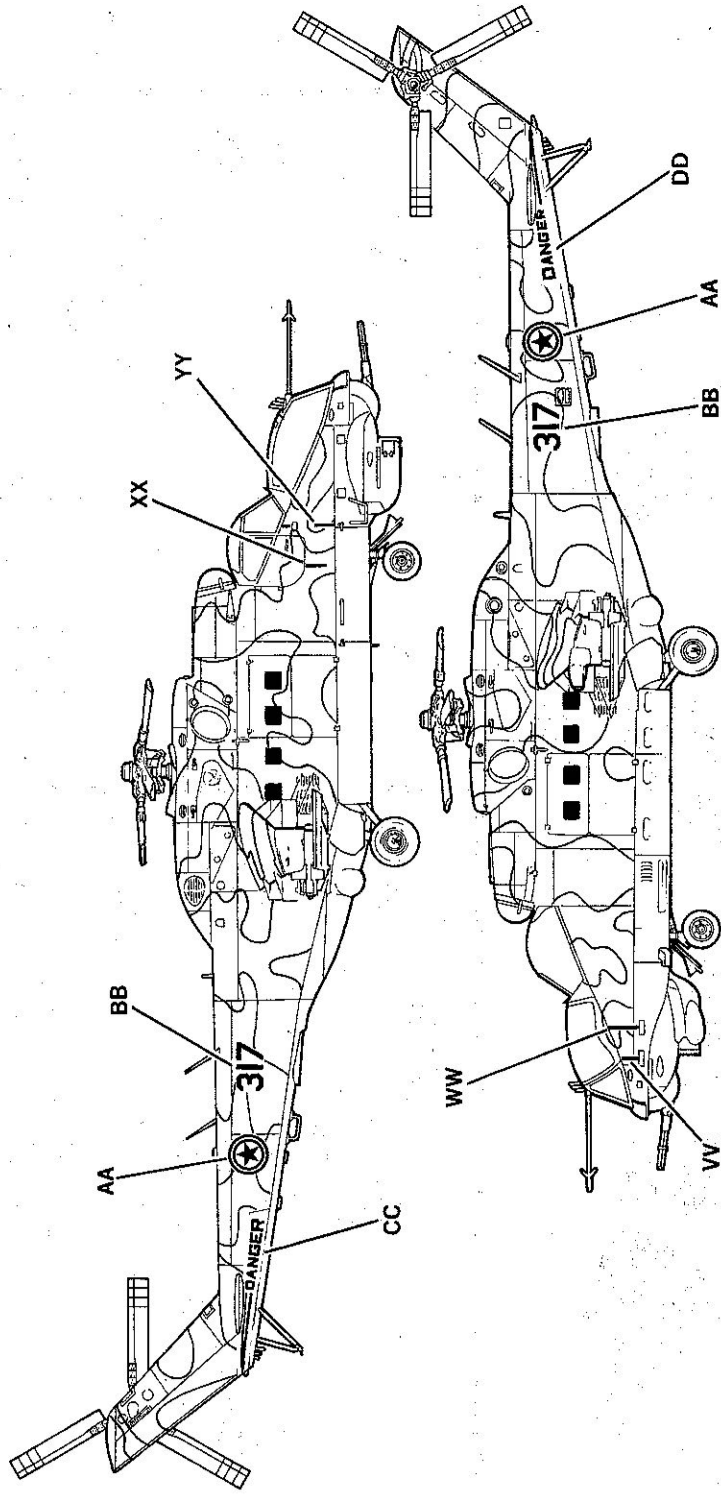
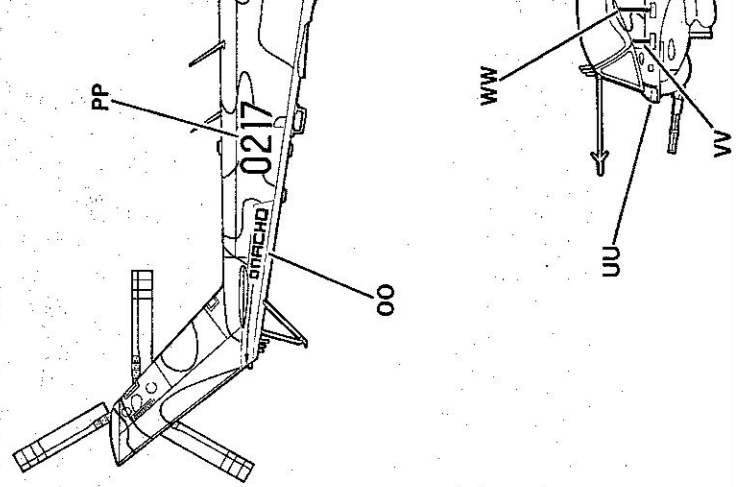
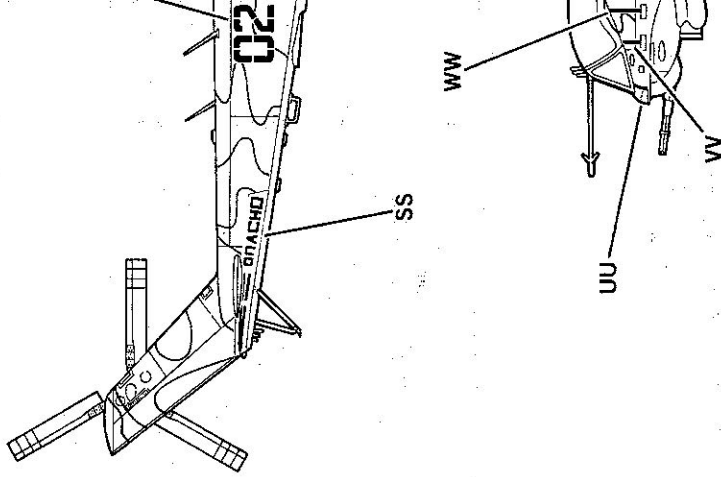

17

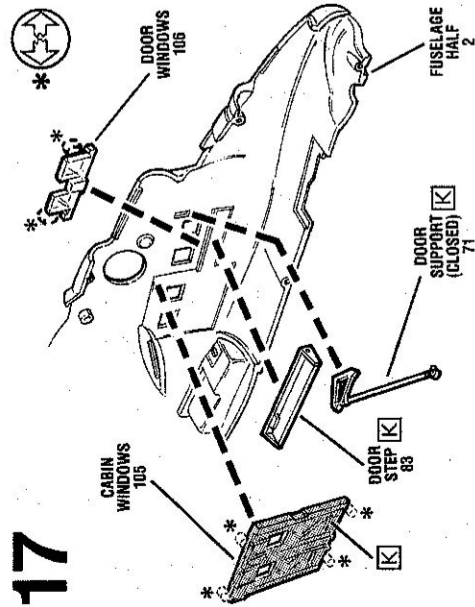

18

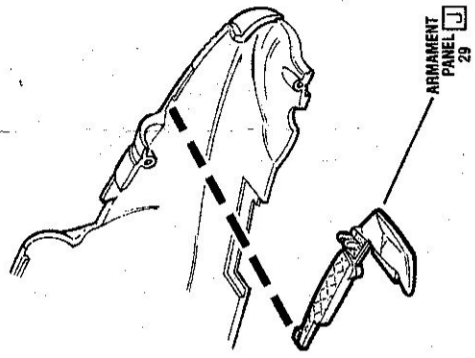

19

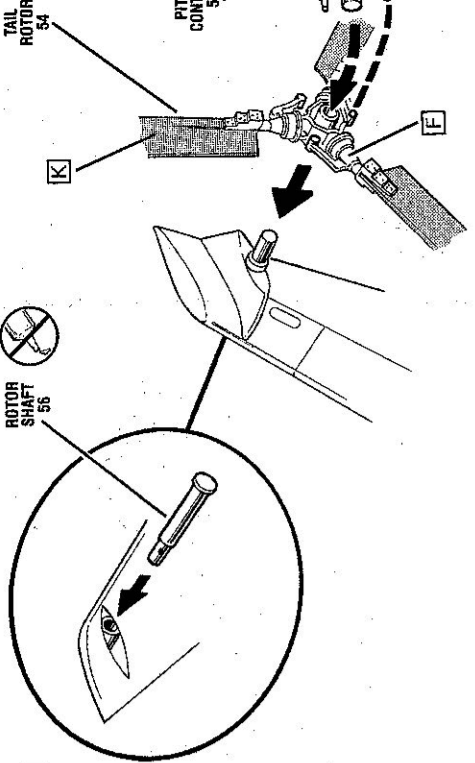

23

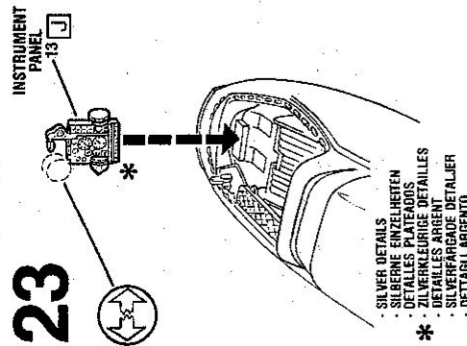

24

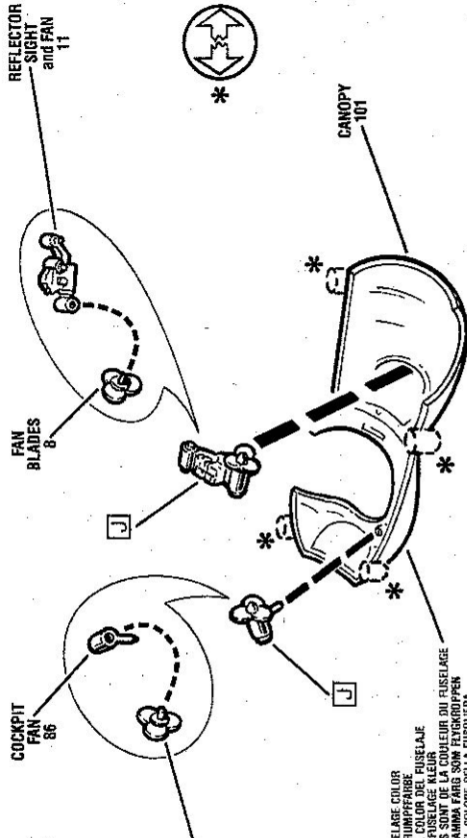

25

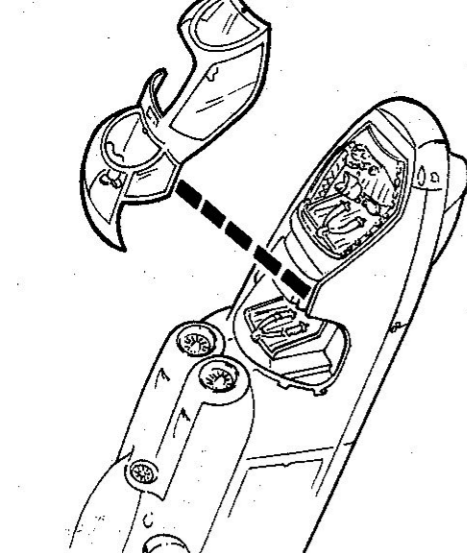

29

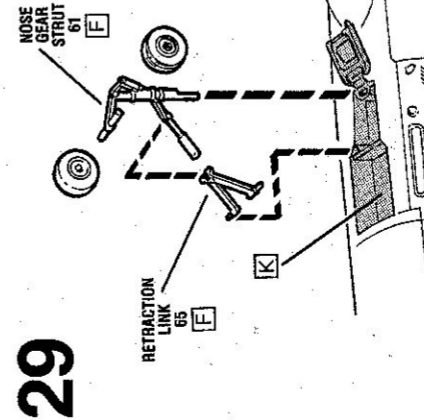

30

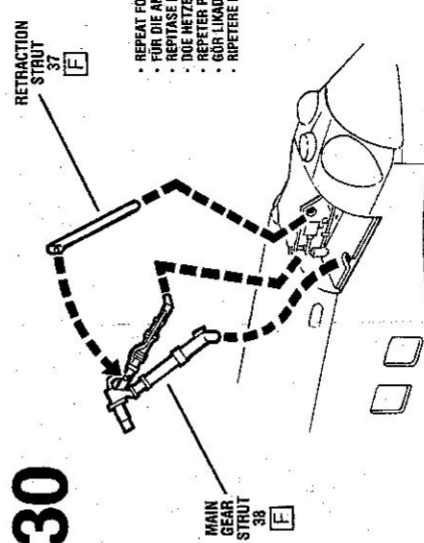

31

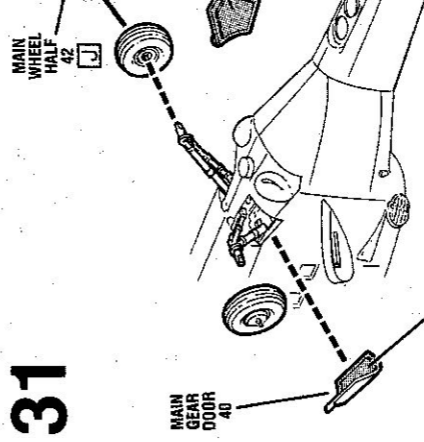

\* FRAME IS FUSELAGE COLOR  
 \* RÄHMEN HAT FÜSSELAGE FARBE  
 \* ARMAZIONE DEL COLORE DEL CAROSALE  
 \* LES MONTANTS SONT DE LA COULEUR DU FUSELAGE  
 \* RÄHMEN HÄR SAMMA FÄRG SOM FLYGKROPPEN  
 \* IL TELAI È DEL COLORE DELLA FUSOLIERA

\* SILVER DETAILS  
 \* SILBERNE EINZELTHEILEN  
 \* DETALLES PLATEADOS  
 \* ZILVERKLEURIGE DETAILLES  
 \* BETALES ARGENT  
 \* DETTAGLI ARGENTO

\* REPEAT FOR OTHER SIDE  
 \* FÜR DIE ANDERE SEITE ZU WIEDERHOLEN  
 \* REPETASE PARA EL OTRO LADO  
 \* DOE HETZELFDE AAN DE ANDERE KANT  
 \* REPETER POUR L'AUTRE COTE  
 \* GÖR LIKADANT PÅ ANDRA SIDAN  
 \* RIPETERE PER L'ALTRA PARTE

20

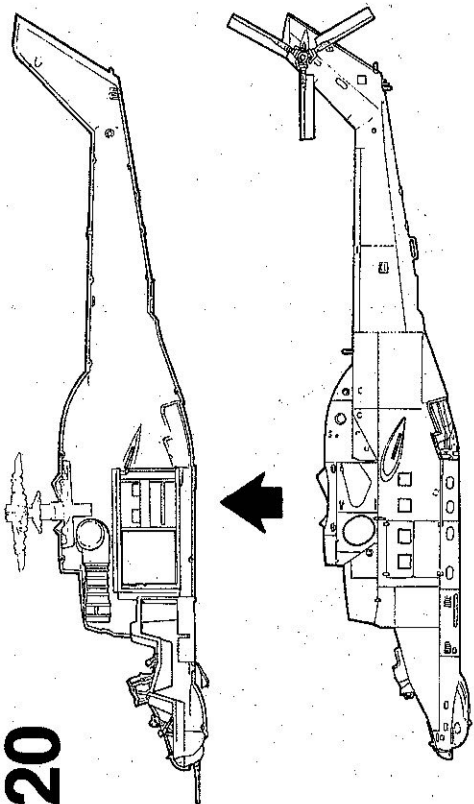

21

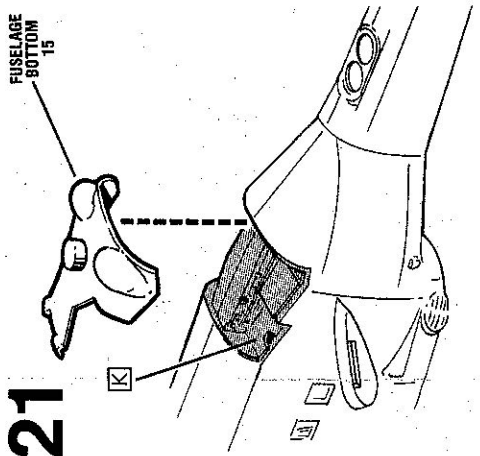

22

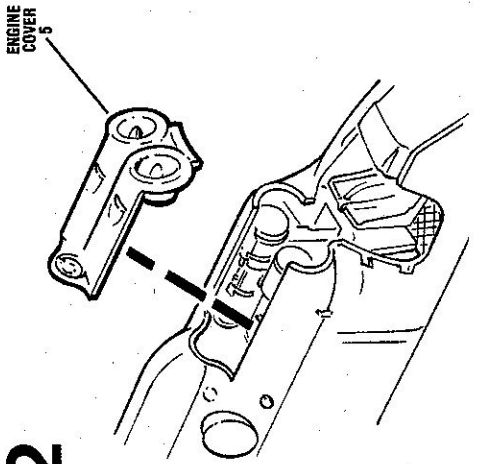

26

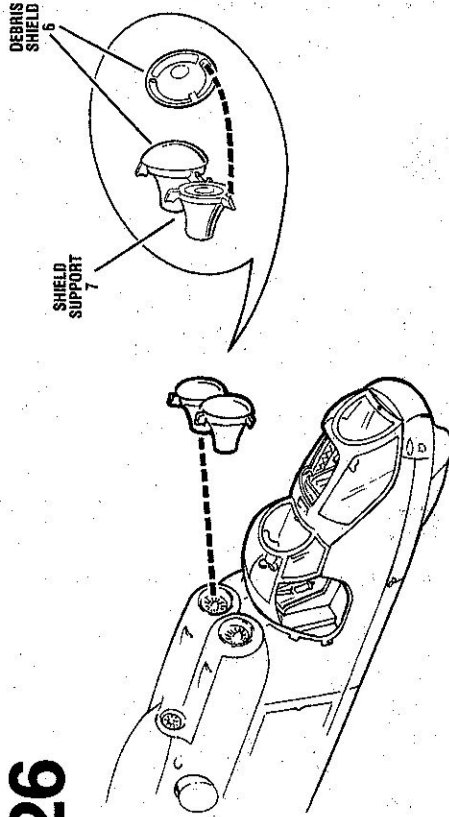

27

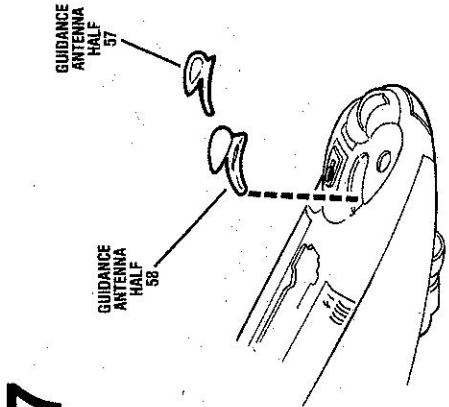

28

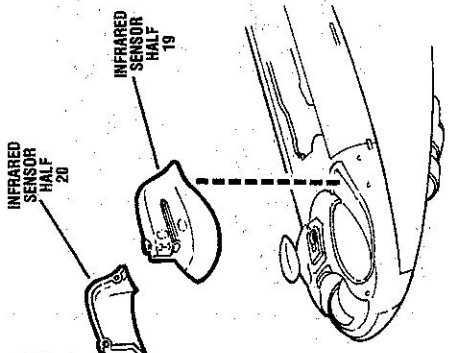

32

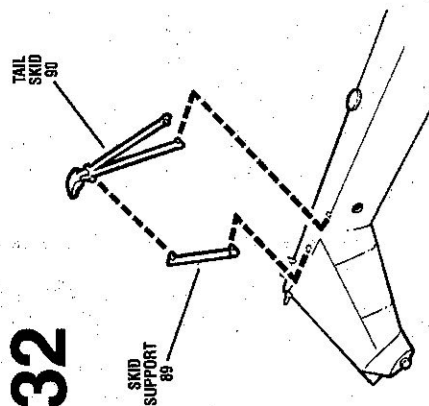

33

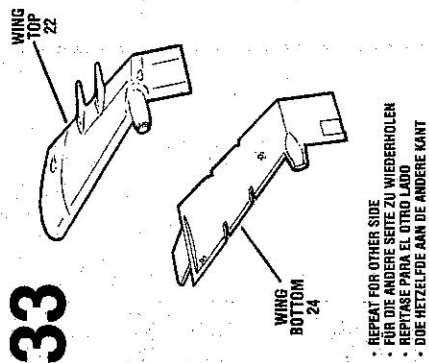

34

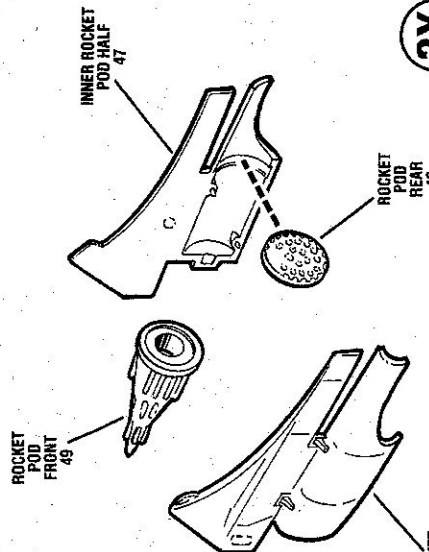

REPEAT FOR OTHER SIDE  
 • FÜR DIE ANDERE SEITE ZU WIEDERHOLEN  
 • REPETIR PARA EL OTRO LADO  
 • DIE HERZELPDE AAN DE ANDERE KANT



# 35

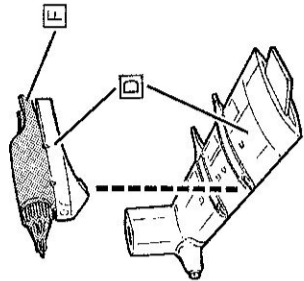

- REPEAT FOR OTHER SIDE
- FÜR DIE ANDERE SEITE ZU WIEDERHOLEN
- REPETIRSE PARA EL OTRO LADO
- DÖE HETZELFÖE AAN DE ANDERE KANT
- REPETER POUR L'AUTRE COTE
- GÖR LÄKADANT PÅ ANDRA SIDAN
- RIPETERE PER L'ALTRA PARTE

# 36

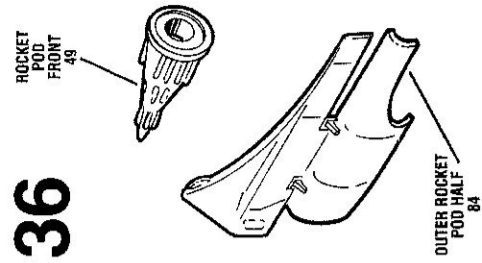

## 2X

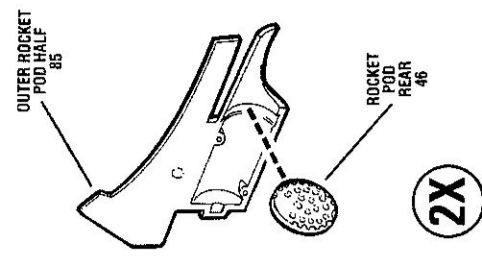

# 37

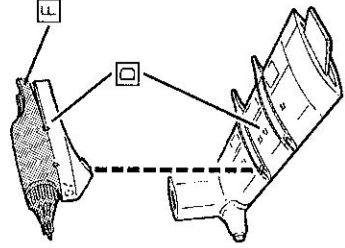

- REPEAT FOR OTHER SIDE
- FÜR DIE ANDERE SEITE ZU WIEDERHOLEN
- REPETIRSE PARA EL OTRO LADO
- DÖE HETZELFÖE AAN DE ANDERE KANT
- REPETER POUR L'AUTRE COTE
- GÖR LÄKADANT PÅ ANDRA SIDAN
- RIPETERE PER L'ALTRA PARTE

# 38

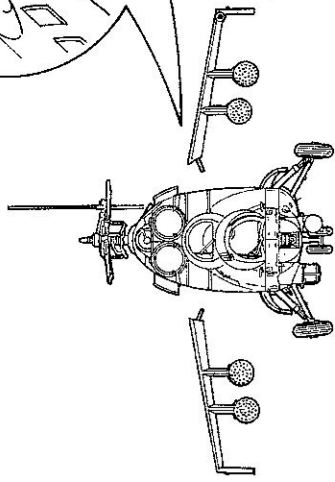

# 42

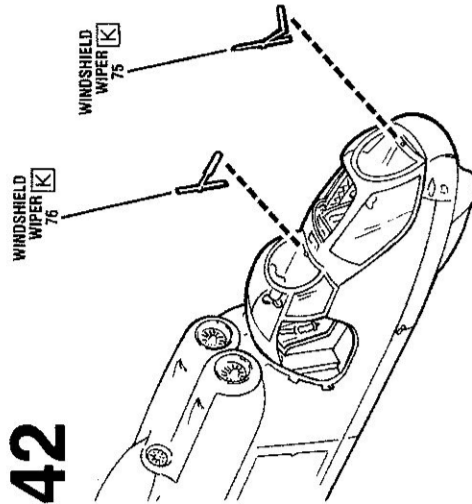

# 43

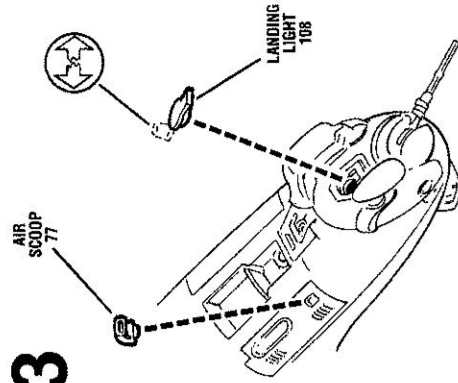

# 44

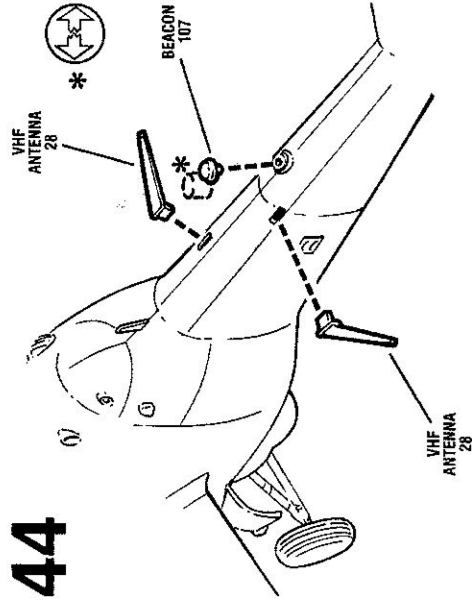

# 45

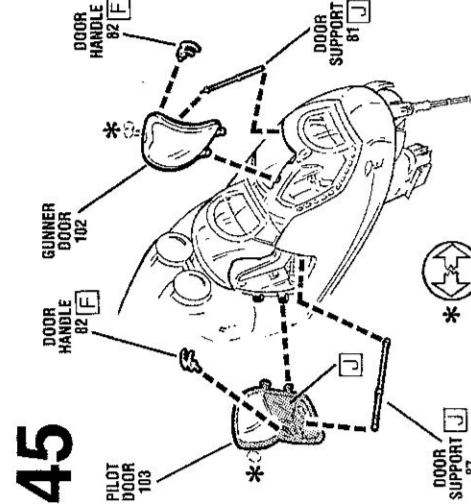

# 46

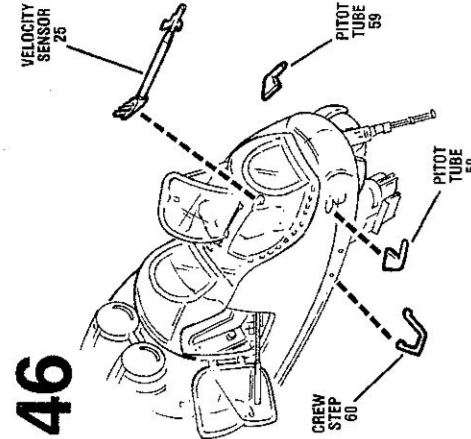

# 47

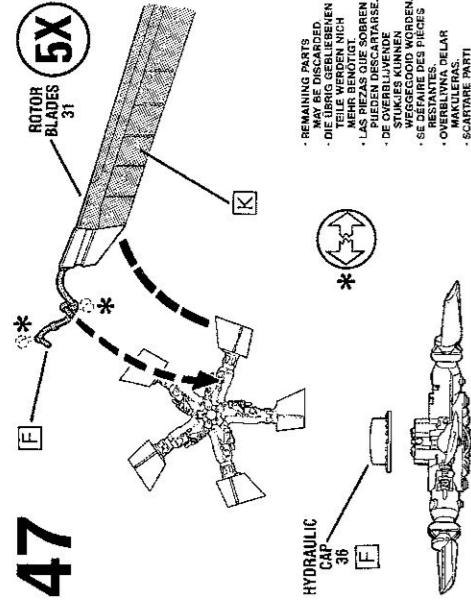

- REMAINING PARTS MAY BE DISCARDED
- DIE ÜBRIGEN TEILE KÖNNEN WEGGEWORREN WERDEN
- LAS PIEZAS QUE SOBREN PUEDEN SER DESHECHADAS
- DE OVERBLIJVENDE STUKKES KUNNEN WEGGEGORPEN WORDEN
- SE RESTANTES PARTES RESTANTES PUESEN DESHECHARSE
- OVERBLIVNA DELAR KÄNNAN SLÄNGAS
- SCARTARE PARTI

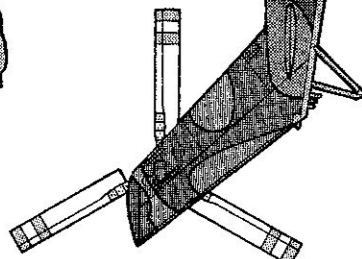
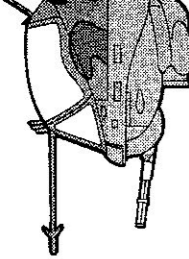

39

TAILPLANE HALF 52

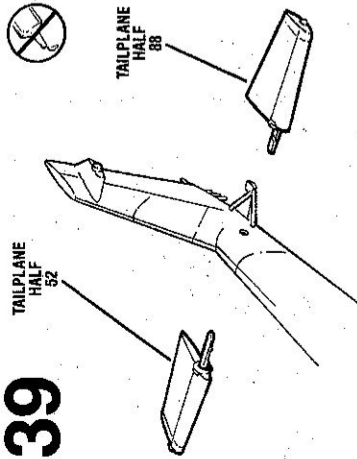

SOME DETAILS OMITTED  
 - CERTAINS DETAILS SUPPRIMÉS  
 - ALCUNOS DETALLES OMITTOS  
 - ENIGME EINSZELHETEN AUSBLASSEN  
 - VISSA DETALIER UTBLANADE  
 - SOMMIGE DETALLES WEGGELATEN  
 - ALCUNI DETTAGLI SONO ELIMINATI

TAILPLANE HALF 56

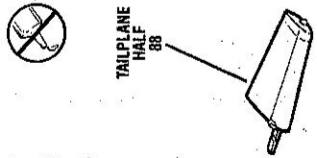

40

MISSILE RACK 50 J

2X

SWATTER MISSILE 51 J

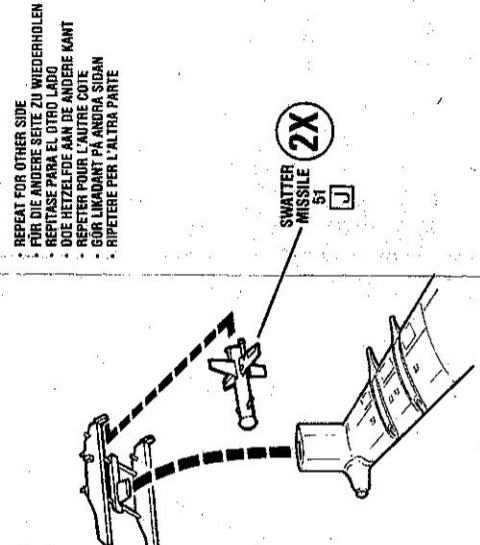

REPEAT FOR OTHER SIDE  
 - FÜR DIE ANDERE SEITE ZU WIEDERHOLEN  
 - REPTASE PARA EL OTRO LADO  
 - DOE HETZELFDE AAN DE ANDERE KANT  
 - REPETER POUR L'AUTRE COTE  
 - GOR LINDADANT FA ANDRA SIDAN  
 - RIPETERE PER L'ALTRA PARTE

41

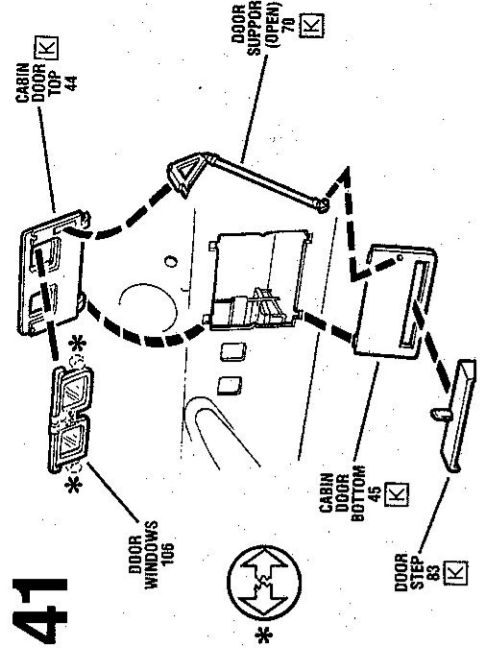

CABIN DOOR TOP 44

DOOR SUPPORT (OPEN) 70 K

CABIN DOOR BOTTOM 45 K

DOOR STEP 83 K

DOOR WINDOWS 106

