



# SCALE MODEL CONSTRUCTION KIT

## HARVARD II

02057

STUDY DRAWINGS AND PRACTICE ASSEMBLY BEFORE CEMENTING PARTS TOGETHER. CAREFULLY SCRAPE PLATING AND PAINT FROM CEMENTING SURFACES. ALL PARTS ARE NUMBERED. PAINT SMALL PARTS BEFORE ASSEMBLY.

ETUDIEZ ATTENTIVEMENT LES DESSINS ET SIMILEZ L'ASSEMBLAGE AVANT DE COLLER LES PIECES. GRATTEZ SOIGNEUSEMENT TOUT REVETEMENT OU PEINTURE SUR LES SURFACES A COLLER AVANT COLLAGE. TOUTES LES PIECES SONT NUMEROTEES. PEIGNEZ LES PETITES PIECES AVANT ASSEMBLAGE.

VOR VERWENDUNG DES KLEBERS ZEICHNUNGEN STUDIEREN UND ZUSAMMENBAU ÜBEN. FARBE UND PLATTIERUNG VORSICHTIG VON DEN KLEBEFLÄCHEN ABKRATZEN. ALLE TEILE SIND NUMERIERT. VOR ZUSAMMENBAU KLEINE TEILE ANMALEN.

STUDIARE I DESIGNI E PRATICARE IL MONTAGGIO PRIMA DI UNIRE INSIEME I PEZZI CON L'ADESIVO. RASCHIARE ATTENTAMENTE LE TRACCE DI SMALTO E CROMATURA DALLE SUPERFICI DA UNIRE CON ADESIVO. TUTTI I PEZZI SONO NUMERATI. COLORARE I PEZZI DI PICCOLE DIMENSIONI PRIMA DI MONTARLI.

ESTUDI LOS DIBUJOS Y PRACTIQUE EL MONTAJE ANTES DE PEGAR LAS PIEZAS. RASPE CUIDADOSAMENTE EL PLATEADO Y LA PINTURA EN LAS SUPERFICIES DE CONTACTO ANTES DE PEGAR LAS PIEZAS. TODAS LAS PIEZAS ESTAN NUMERADAS. ES CONVENIENTE PINTAR LAS PIEZAS PEQUEÑAS ANTES DE SU MONTAJE.

BESTUDEER DE TEKENINGEN EN PROBEER HET SAMENVOEGEN. VOORDAT JE DE ONDERDELEN AAN ELKAAR VASTPLAakt. SCHUUR VOORZICHTIG HET VERGULSEL EN DE VERF VAN DE VAST TE PLAKKEN VLAKKEN. ALLE ONDERDELEN ZIJN GENUMMERD. VERF DE KLEINE ONDERDELEN AL VORENS SAMEN TE VOEGEN.

STUDERA BILDERNA NOGGRANT OCH SÄTT IHOP DELARNA INNAN DU LIMMAR IHOP DEM. SKRAPA NOGGRANT BORT FÖRKROMNING OCH FÄRG FRÅN LIMMADE DELAR. ALLA DELARNA ÄR NUMRERADE. MALA SMADELARNA FÖRE IHOPSÄTTNING.

TUTUSTU PIIRROKSIINN JA HARJOITTELE KOKOAMISTA ENNEN KUIN LIIMAAT OSAT YHTEEN. RAAPUTA MAALI VAROVASTI POIS LIIMATTAVILTA PINNOILTA. KAIKKI OSAT ON NUMEROITU. MAALAA PIENET OSAT ENNEN KOKOAMISTA.

ESTUDE ATENTAMENTE OS DESENHOS. CORTE AS PECAS DAS GRELHAS COM A AJUDA DE UMA LAMINA E LIXE AS ARESTAS DE MODO A SUPRIMIR QUALQUER IRREGULARIDADE. EXPERIMENTE SE AS PECAS ENCAIXAM FÁCILMENTE UMAS NAS OUTRAS ANTES DE COLAR. TODAS AS PECAS ESTAO NUMERADAS. PINTA AS PEQUENAS PECAS ANTES DE COLAR.

TEGNINGERNE BOR STUDERES, OG MAN BOR OVE SIG I MONTERINGEN, FOR DELENE LIMES SAMMEN. PLADESTYKKER OG MALING SKAL OMHYGGELIGT FJERNES FRA KLAEBEOVERFLADERNE. ALLE DELE ER NUMMEREREDE; SMA DELE SKAL MALES FOR MONTERINGEN.

The varying shades of colour shown in the illustration can be obtained by blending the listed paints.

Les diverses nuances figurant sur l'illustration peuvent être obtenues en mélangeant les couleurs indiquées.

Die verschiedenartigen Farbschattierungen, die auf der Abbildung zu sehen sind, erhält man durch mischen der aufgeführten Farben.

I diversi colori mostrati nell'illustrazione possono essere ottenuti mischiando le vernici elencate.

Los distintos matices de color que se muestran en la ilustración pueden obtenerse mezclando las pinturas de la lista.

Voor het verkrijgen van de verschillende afgebeelde kleurnuances de in de lijst genoemde verf mengen.

De pa bilden visade olika färgnyanserna kan erhållas genom blandning av de pa listan uppförda färgerna.

Kuvassa näkyvät eri värisävyt voidaan valmistaa sekoittamalla luettelossa olevia maaleja.

As várias tonalidades de cores apresentadas na ilustração podem ser obtidas mesclando as tintas que figuram na lista.

De i illustrationen viste forskjellige farvenuancer kan fås ved at blande de pa listen anførte farver.



CEMENT  
COLLEZ  
KLEBEN  
UNIRE CON ADESIVO  
CON PEGAMENTO  
VASTPLAKKEN  
LIMMA  
LIMAA  
COLAR  
KLAEBEMIDDEL



CLEAR  
CLAIR  
KLAR  
TRANSPARENTE  
SCHOOON  
GENOMSKINLIG  
KIRKAS  
TRANSPARENTE  
KLAR



ALTERNATIVE PART  
PIECE EN OPTION  
ALTERNATIVTEN  
PEZZO ALTERNATIVO  
ANDER ONDERDEEL  
ALTERNATIV DEL  
VAIHTOEHTOINEN OSA  
PECAS ALTERNATIVAS  
ALTERNATIV DEL



DO NOT CEMENT  
NE COLLEZ PAS  
NICHT VERKLEBEN  
NON APPLICARE ADESIVO  
SIN PEGAMENTO  
NIET VASTPLAKKEN  
LIMMA INTE  
ÄLÄ LIIMAA  
NAO COLAR  
MA IKKE KLAEBES



ASSEMBLED SECTION  
PARTIE DEJA ASSEMBLEE  
ZUSAMMENGEBAUTER TEIL  
SEZIONE MONTATA  
SECCION MONTADA  
SAMENGE VOEGD ONDERDEEL  
IHOPSATT  
KOOTUT OSAT  
SECCAO MONTADA  
MONTERET SEKTION

TO APPLY DECALS, CUT SHEET AS REQUIRED, DIP IN WARM WATER FOR A FEW SECONDS, SLIDE OFF BACKING INTO POSITION SHOWN. USE IN CONJUNCTION WITH BOX ARTWORK.

POUR COLLER LES DECALQUES, DECOUPEZ LE MOTIF PLONGEZ-LE QUELQUES SECONDES DANS L'EAU CHAUDE PUIS POSEZ LE A L'ENDROIT INDIQUE EN DECOLLANT LE SUPPORT PAPIER. UTILISER EN MEME TEMPS L'ILLUSTRATION DE LA BOITE.

UM DIE ABZIEHBILDER AUFZUKLEBEN, DIESE AUSSCHNEIDEN, KURZ IN WARMES WASSER TAUCHEN, DANN ABZIEHEN UND WIE ABGEBILDET AUFKLEBEN. IN VERBINDUNG MIT SCHACHTEL-ARTWORK VERWENDEN.

PARA APLICAR LAS CALCOMANIAS, SEPARAR LOS TEMAS DESEADOS, SUMERGIR EN AGUA TIBIA DURANTE UNOS SEGUNDOS Y DESLIZAR LA CALCA EN LA POSICION DEBIDA. VER ILLUSTRACIONES DE LA TAPA.

PER APPLICARE LE DECAL COMANIE, TAGLIARE IL FOGLIO SECONDO IL NECESSARIO, IMMERGERE LA DECORAZIONE IN ACQUE CALDA PER ALCUNI SECONDI, QUINDI SFILARLA DALLA CARTA DI SUPPORTO E PALPEGGIARLA NELLA POSIZIONE INDICATA. USARE IN CONJUNZIONE CON L'ILLUSTRAZIONE SULLA SCATOLA.

OVERFORING AV DEKALER KLIPP ARKET SLIK DU ONSKER. DYPP DET I VARMT VANN NOEN SEKUNDER, OG LA DET GLI FRA BAKGRUNNSARKET DIREKTE PA PLASS SOM VIST BRUKES SAMMEN MED KARTONGENS LITOGRAFI.

FASTSÄTTNING AV DEKALER, KLIPP ARKET, DOPPA I VARMT VATTEN NAGRA SEKUNDER. LAT BAKSIDAN GLIDA PA PLATS SOM BILDEN VISAR. ANVANDS I SAMBAND MED KARTONGENS HANDLITOGRAFI.

OM DE PLAAT JES OP TE PLAKKEN MOET HET BLAD GEKNIPT WORDEN ZOALS AANGEGEVEN, EEN PAAR SECONDEN IN WARM WATER GEDOMPELD WORDEN EN DE ACHTERKANT ERAF GEHAALD WORDEN ZOALS AFGEBEELD STAAT GEBRUIK SAMEN MET AFBEELDING OP DOOS.

PARA APLICAR AS DECALCOMANIAS, CORTAR AS FOLHAS A MEDIDA DO SIMBOLO PRETENDIDO E MERGULHA-LO EM AGUA MORNIA POR ALGUNS SEGUNDOS DEPOIS, COM A AJUDA DE UMA PINÇA. DESLIZA-LO APLICANDO NO RESPECTIVO LUGAR.

OVERFORINGSBILLEDERNE ANVENDES VED AT TILKLIPPE ARKET EFTER BEHOV, OG DYPPE DET I VARMT VAND I NOGLE FA SEKUNDER. UNDERLAGET GLIDES AF OG ANBRINGES I DEN VISTE POSITION. PAFORES IFOLGE BRUGSANVISNINGERNE PA AESKEN.



1

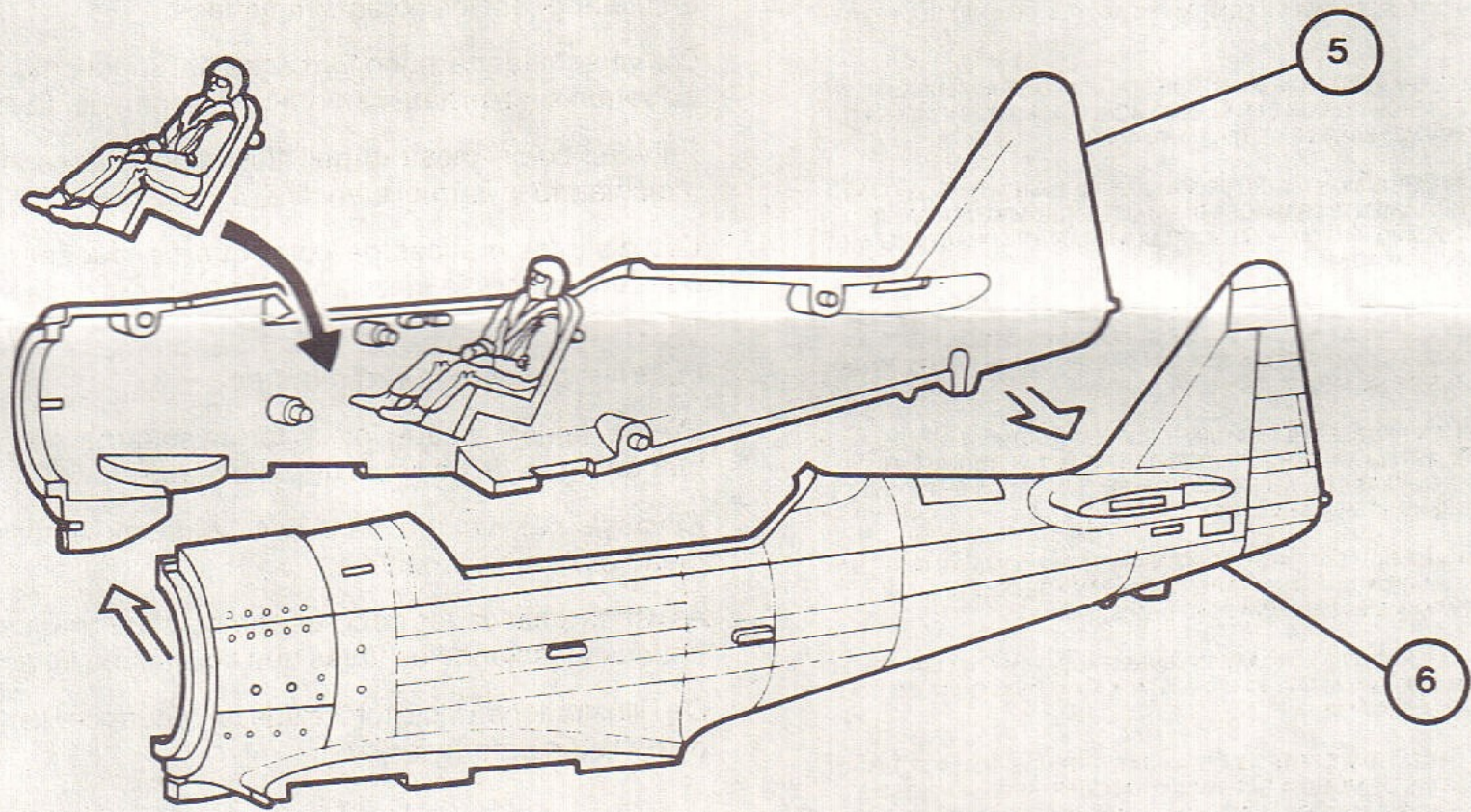
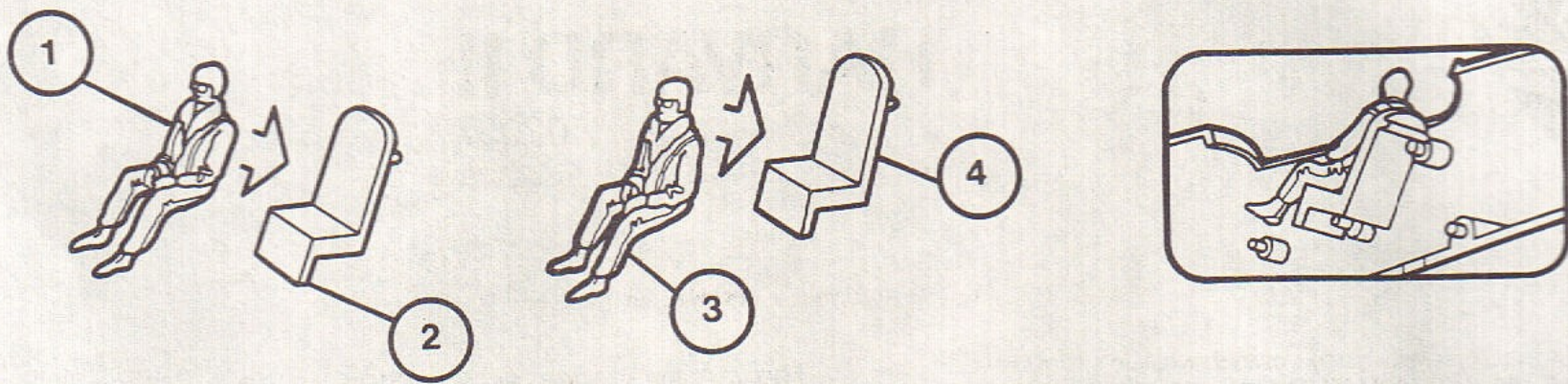

2

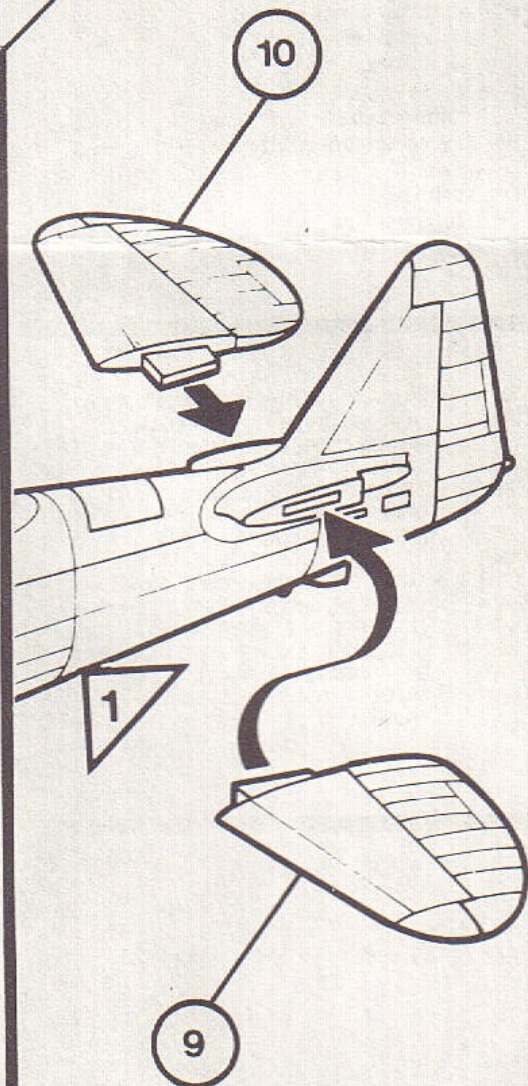

3

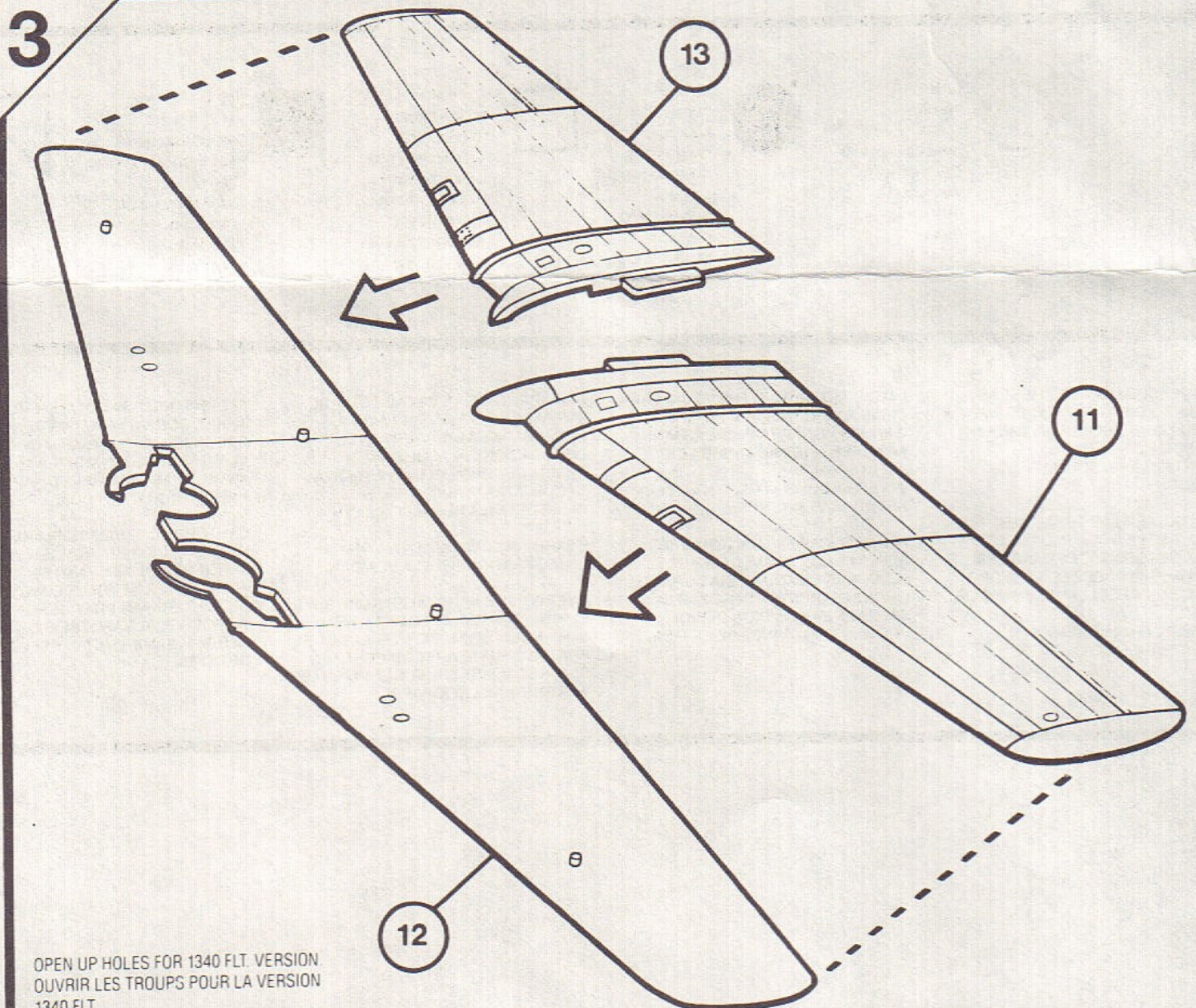

OPEN UP HOLES FOR 1340 FLT. VERSION.  
 OUVRIR LES TROUPS POUR LA VERSION  
 1340 FLT.  
 FÜR 1340 FLT. VERSION. LÖCHER OFFNEN.



4

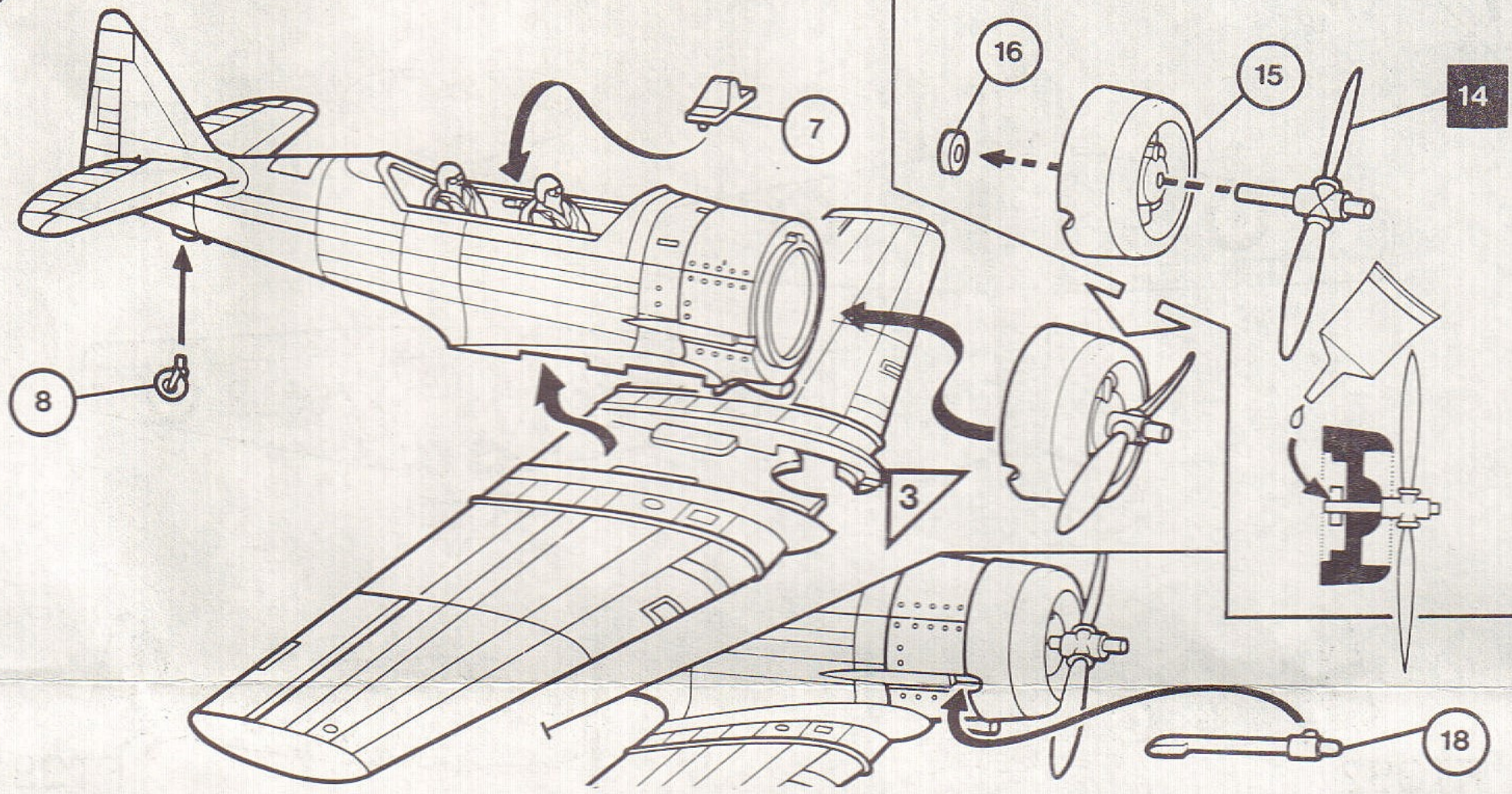

5

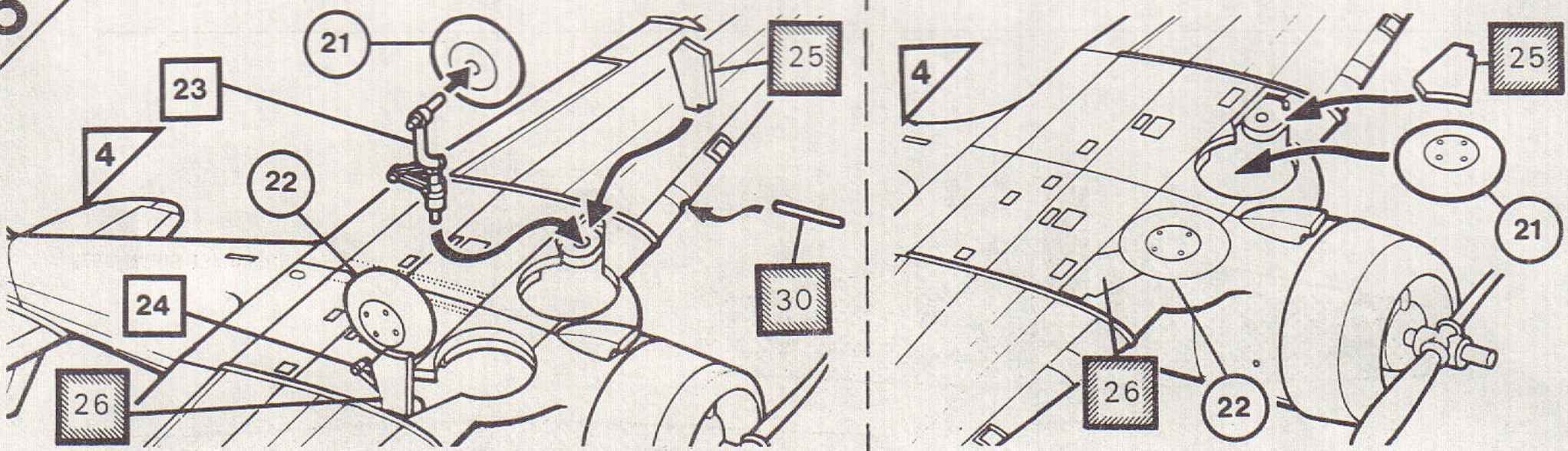

6

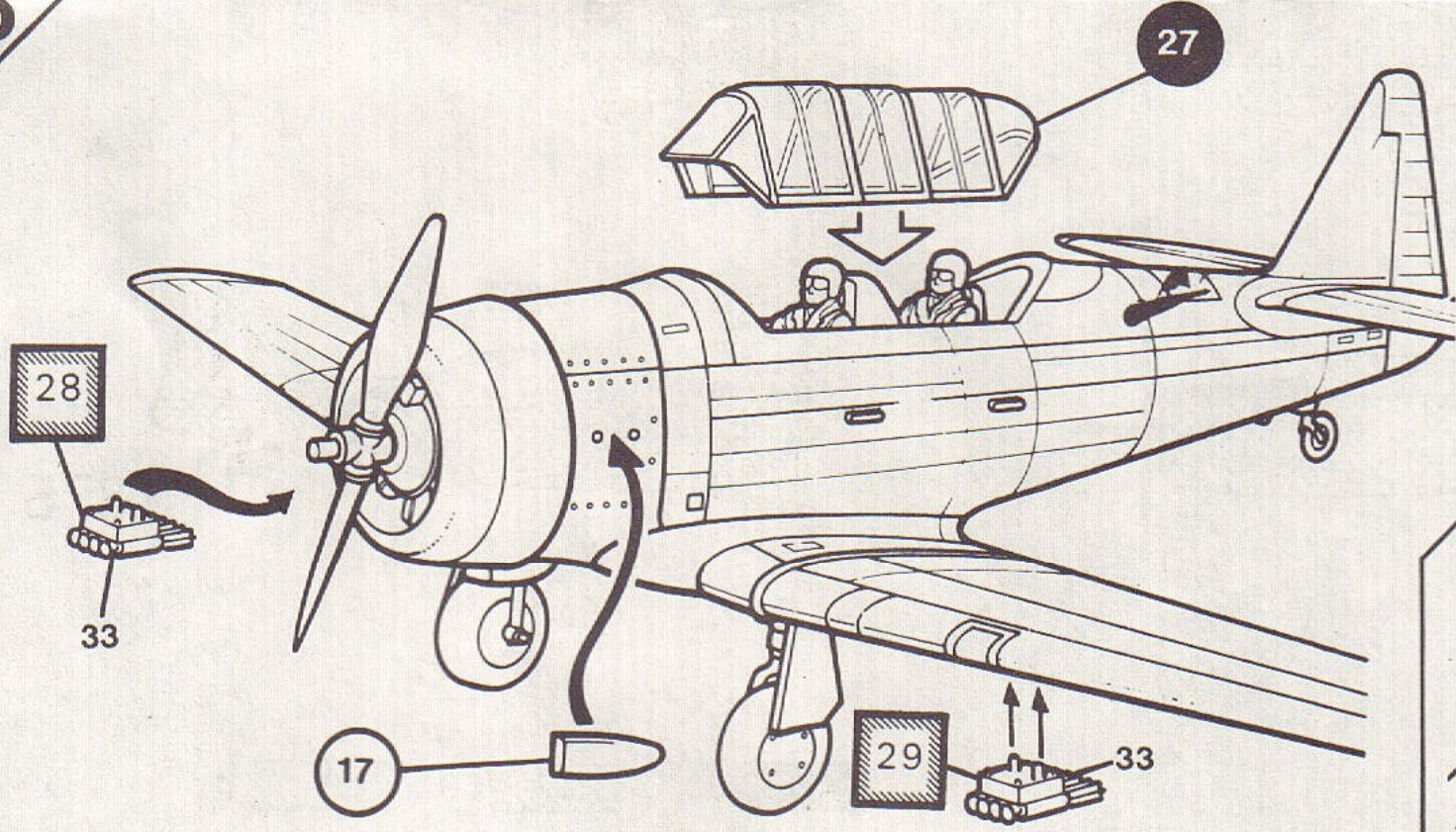

FOR 1340 FLT. VERSION APPLY TRANSFERS BEFORE CEMENTING PARTS 28 AND 29  
 POUR LA VERSION 1340 FLT. APPLIQUER LES DECALCOMANIES AVANT DE COLLER LES PIECES 28 ET 29  
 FÜR DIE FLT. VERSION. ABZIEHBILDER VOR DEM KLEBEN DER TEILE 28 UND 29 ANBRINGEN

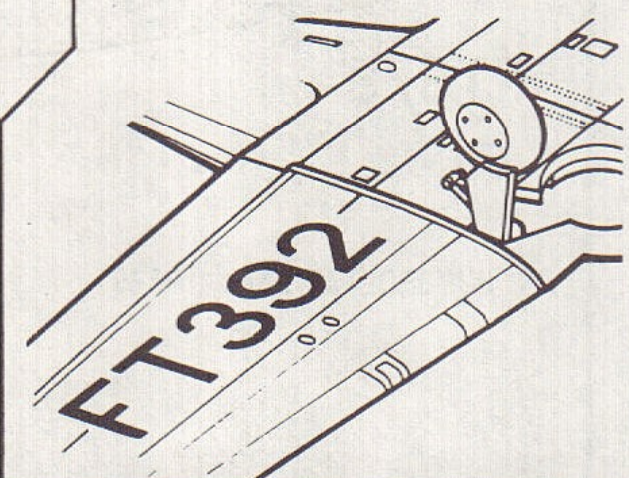



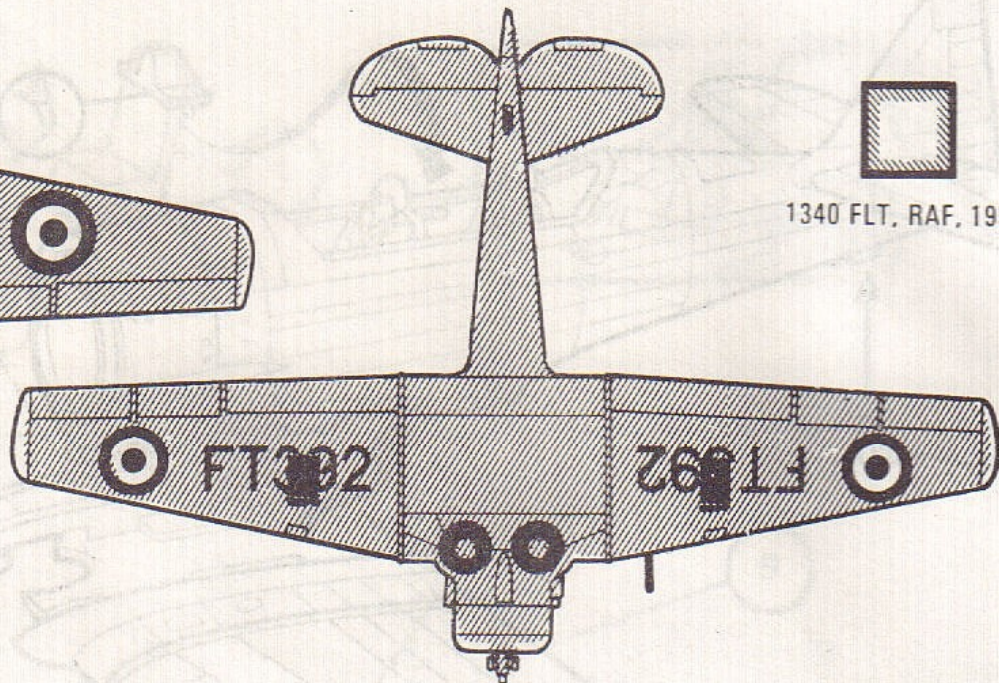
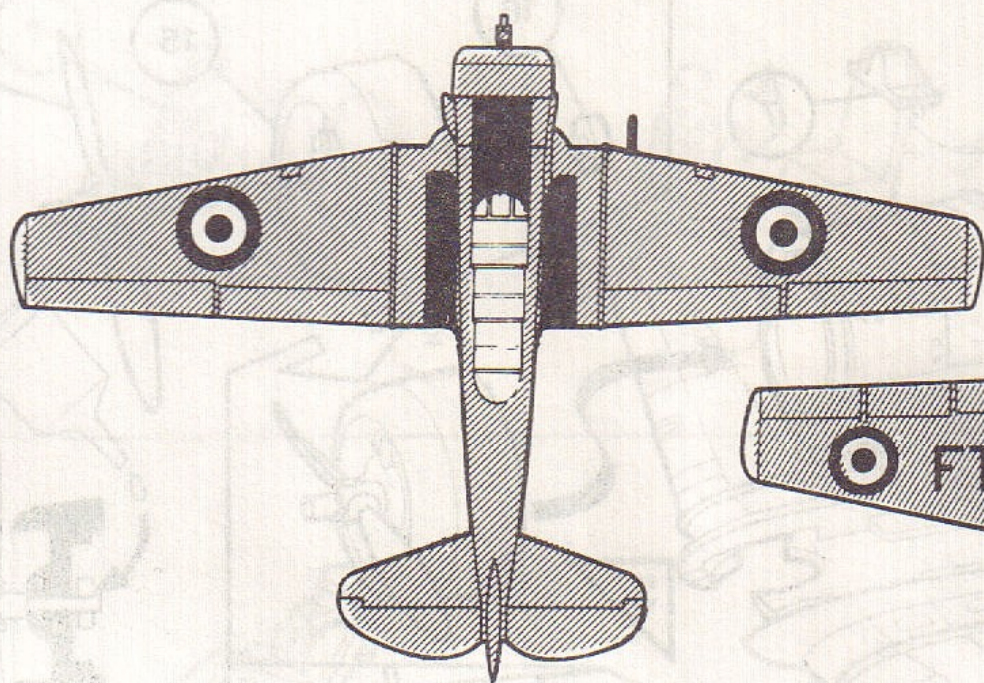

1340 FLT. RAF, 1954.

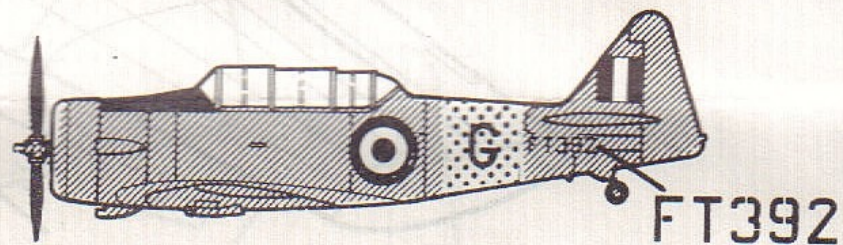
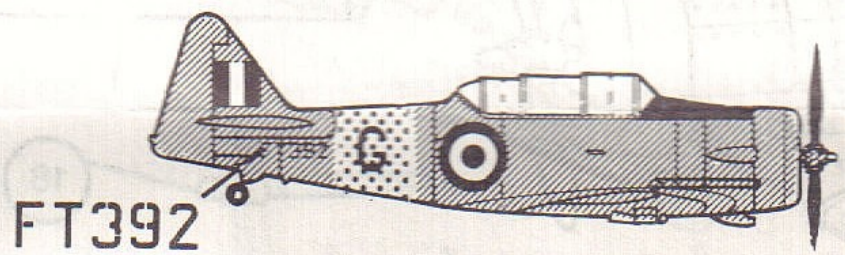

HUMBROL PAINT Nos. 11 33 69

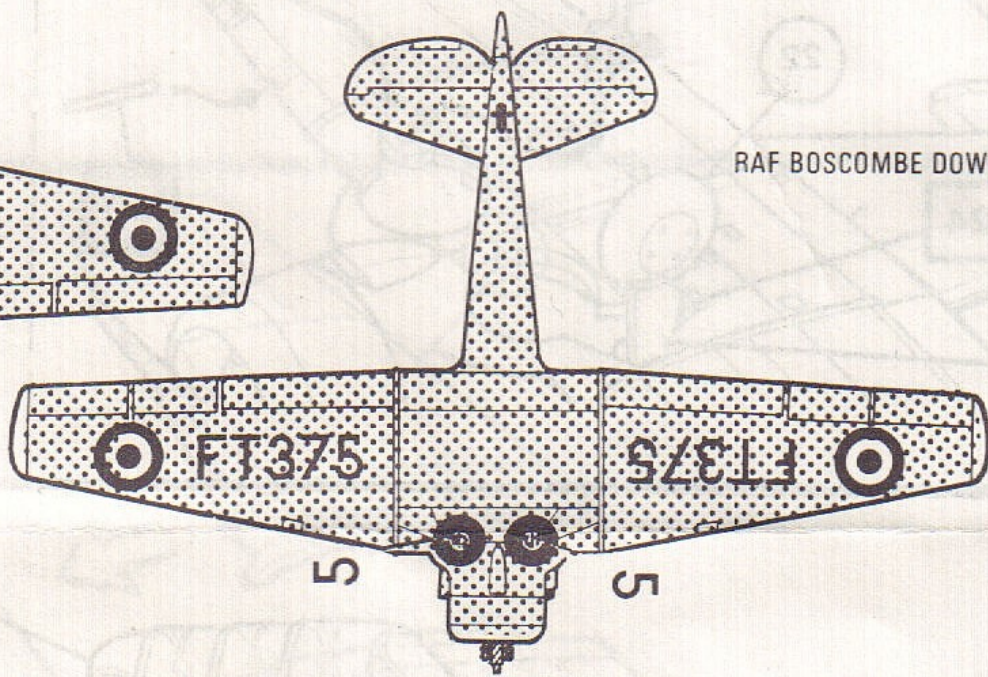
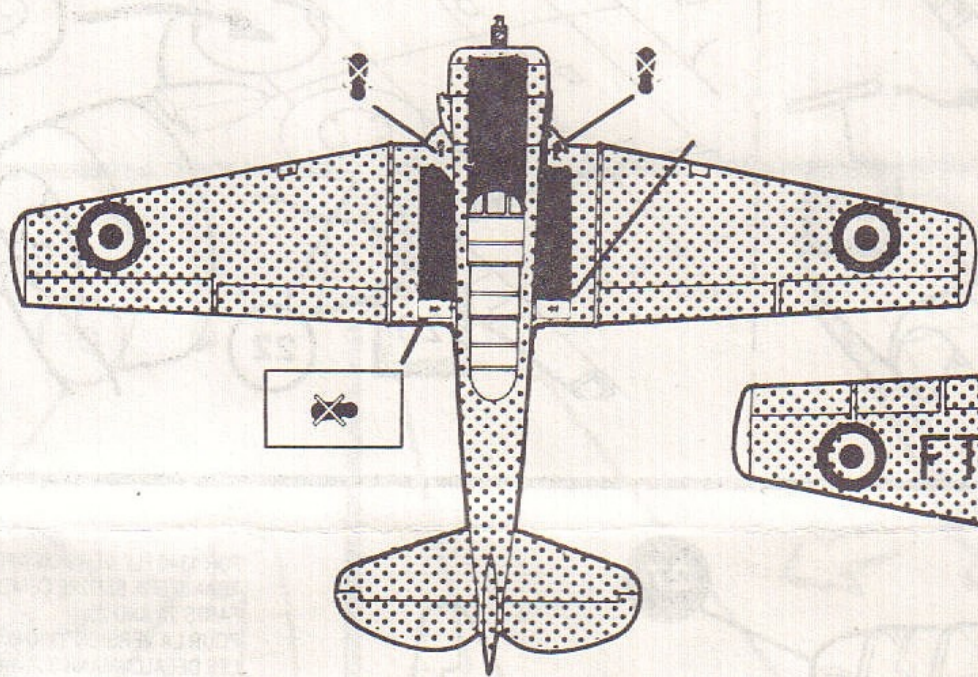

RAF BOSCOMBE DOWN, 1978.

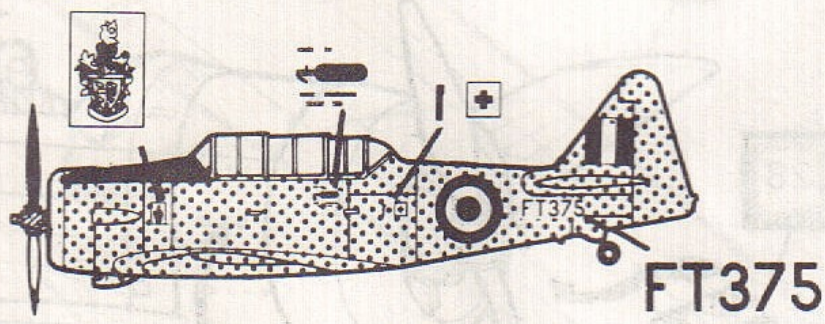
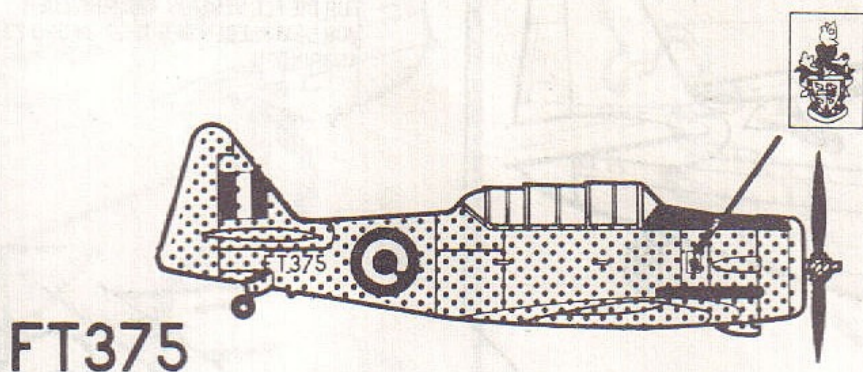

FT375

FT375

HUMBROL PAINT Nos. 11 33 69



33



69



11