

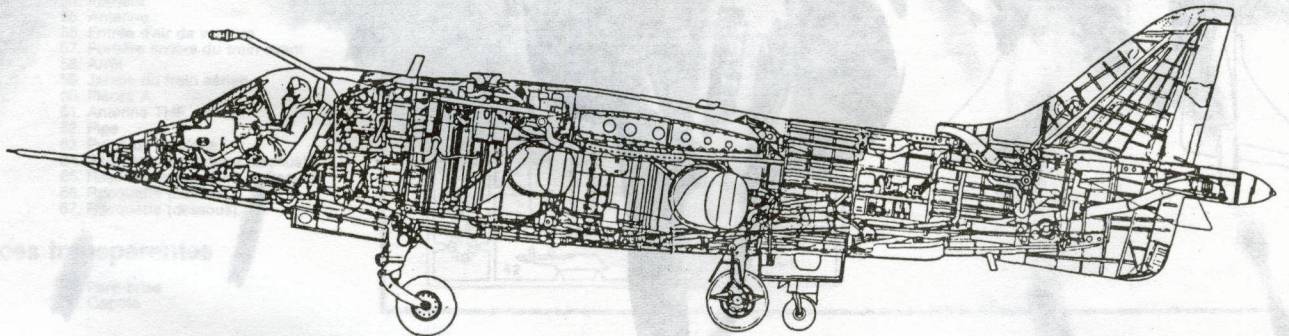

1/48 Hawker Siddeley **HARRIER GR.MK1**
V/STOL Fighter/Chasseur

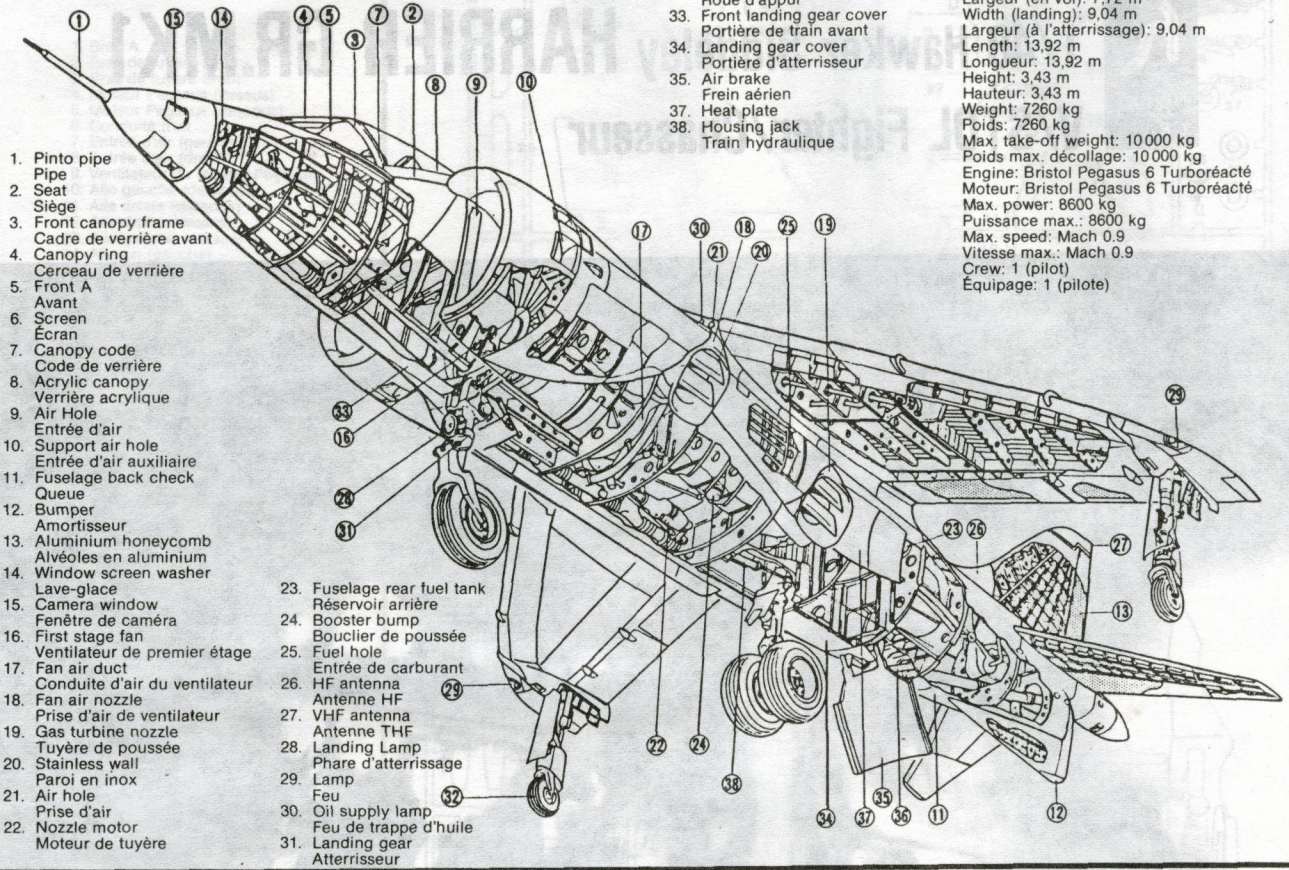

HARRIER GR MK1 DATA/DONNÉES



The Harrier, which can fly at Mach 0.9 and up to Mach 1.25 in full descent, is equipped with 8600 kg Pegasus 6 Rolls-Royce Bristol engine. This plane is of the V/STOL type, meaning Vertical Short Take Off and Landing. This is accomplished by means of 4 engine lateral-mounted nozzles with a 94 degree variation angle. It is equipped with numerous weapons and reconnaissance pods and can also be refueled in flight. Due to its great capabilities and its uniqueness, the Harrier has drawn considerable attention and concern in its strategic value.

Le Harrier, qui peut voler à Mach 0,9 et jusqu'à Mach 1,25 en piqué, est doté d'un moteur Pegasus 6 Rolls-Royce Bristol de 8600 kg. Cet aéronef est de type V/STOL, ce qui signifie décollage et atterrissage à la verticale. Ceci est accompli au moyen de tuyères sur les flancs du fuselage qui s'orientent sur 94 degrés. Le Harrier est équipé de diverses armes et appareils de reconnaissances et peut aussi être ravitaillé en vol. Par ses capacités et son caractère unique, le Harrier a soulevé énormément d'intérêt à cause de sa grande valeur stratégique.

**Read this before assembly
Lire ceci avant l'assemblage**

Study the instructions and photographs before commencing assembly.
You will need a sharp knife, a file and a pair of pliers.
Use cement sparingly. Use only enough to make a good bond.
Apply cement to both parts to be joined.
Étudiez les instructions et les photos avant de procéder.
Il faut un couteau tranchant, une lime et des pinces.
Utiliser la colle avec modération. Ne mettre qu'une quantité suffisante pour un bon lien.
Appliquer la colle sur les deux pièces à unir.

1 (Engine Assembly/Moteur)

Snap A1 and A3 into A1 and place as illustrated. Cement A4 to A5 taking care not to cement the A1-A2-A3 assembly.

Enclencher A2 et A3 sur A1 et placer comme illustré. Coller A4 et A5 en prenant soin de ne pas coller l'ensemble A1-A2-A3.

2 (Canopy Assembly/Verrière)

Make sure cement does not run when cementing clear parts.

Faire attention aux filets de colle lors de l'assemblage des pièces transparentes.

3 (Seat Assembly/Siège)

Paint pilot as indicated below.

Peinturer le pilote comme indiqué.

(Painting pilot/Peinture du pilote)

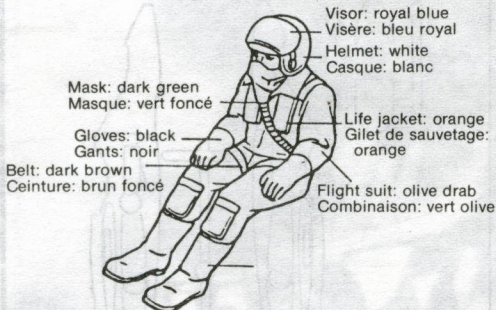

4 (Fuselage)

Cement engine and seat to fuselage section. Assemble canopy. Cement fuselage sections together. Caution: make sure cement does not run on clear plastic parts.

Coller le moteur et le siège à une section du fuselage. Assembler la verrière. Coller les sections de fuselage. Mise en garde: attention aux filets de colle sur les pièces transparentes.

1 Engine assembly — Moteur

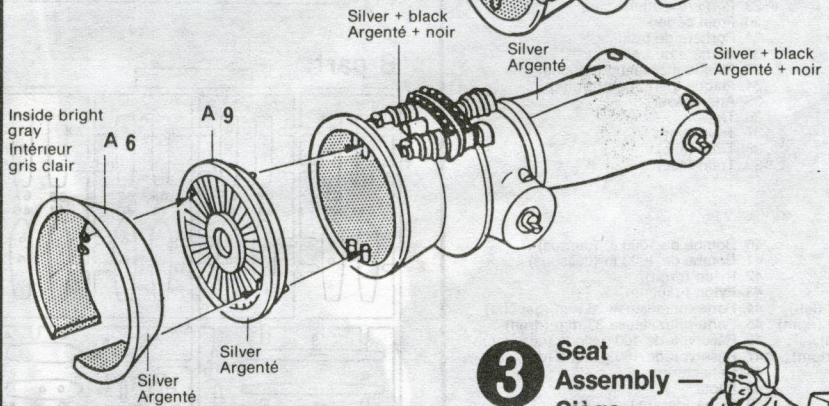
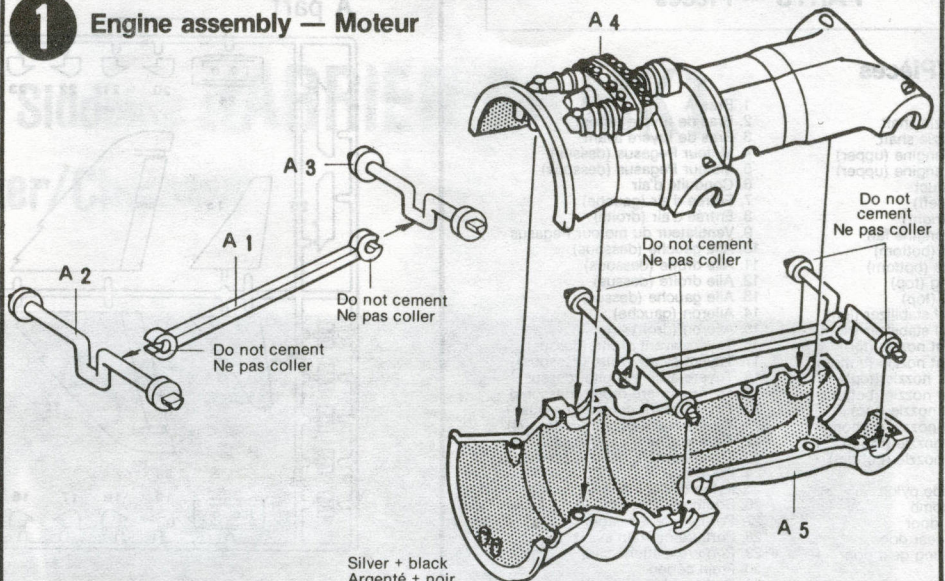

2 Canopy assembly — Verrière

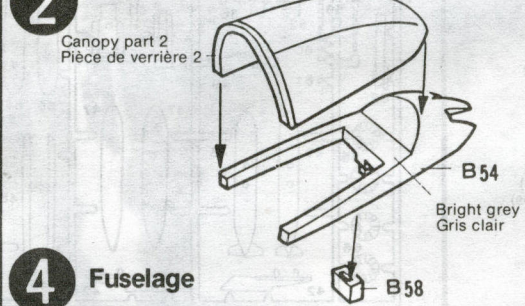

3 Seat Assembly — Siège

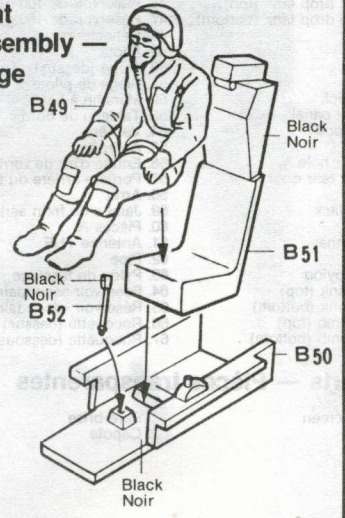

4 Fuselage

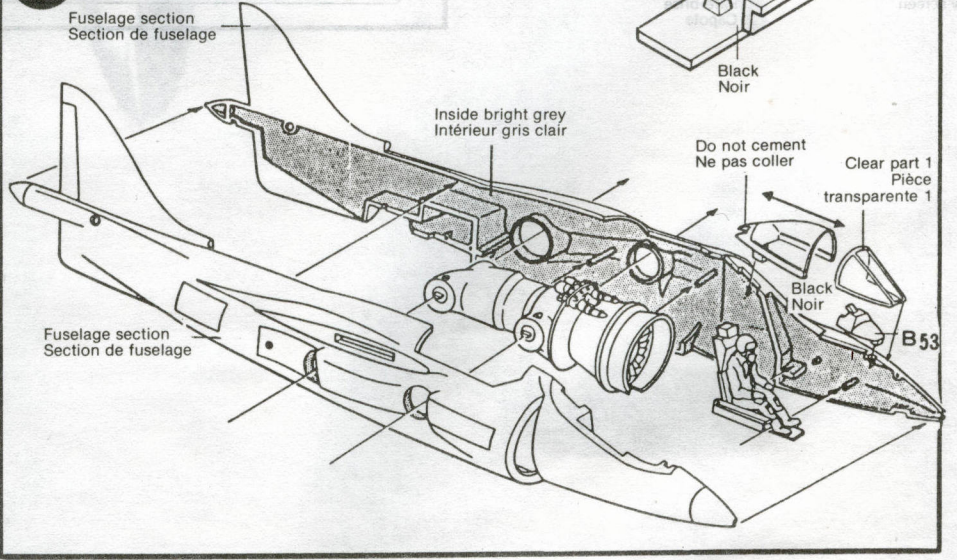

5 (nozzle Assembly/Tuyères)

Follow the numerical order when cementing nozzle sections together. Coller les sections de tuyères en suivant l'ordre numérique.

6 (Fuselage part assembly/Pièces de fuselage)

Cement nozzles in order (A, B, C, D) with care. They must be moveable. Cement A33 and A34. Coller les tuyères en ordre (A, B, C, D) avec soin. Elles doivent tourner. Coller A33 et A34.

Push and insert with thumb. Placer et insérer avec le pouce.

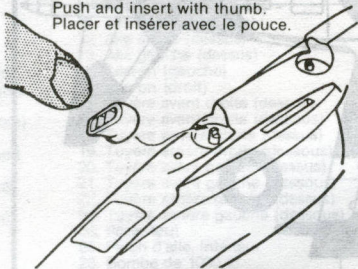

7 (Wing assembly/Ailes)

Cement wings (A12, A10) then position decals (See decal positioning overleaf). Finally, cement pylon. Coller les ailes (A12, A10) puis poser les appliques (voir la position au verso). Enfin, coller le pylonn.

Pegasus 5 Engine



8 (Wing assembly/Ailes)

Affix decals in position. Poser les appliques.

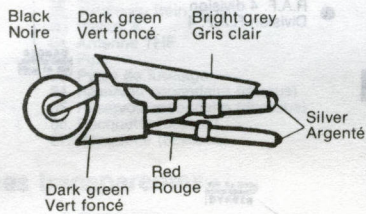

5 Nozzle assembly Tuyères

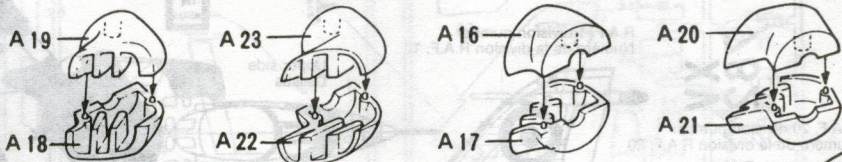

6 Fuselage

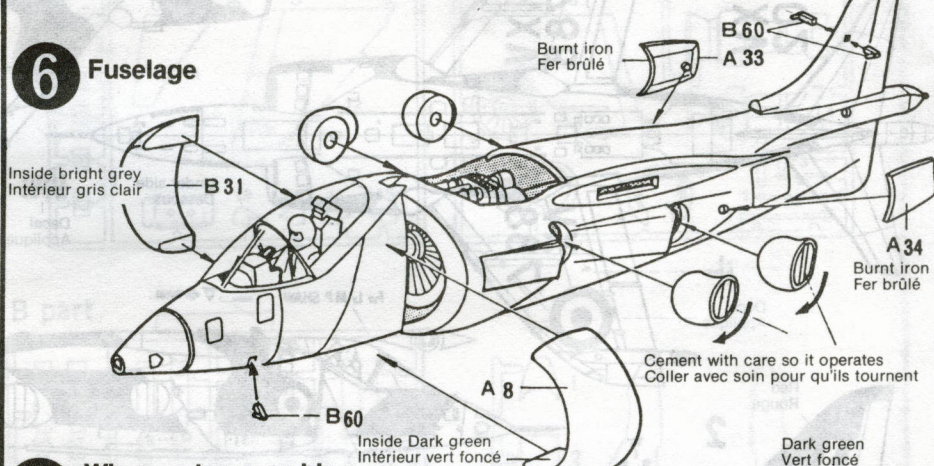

7 Wing parts assembly Pièces d'ailes

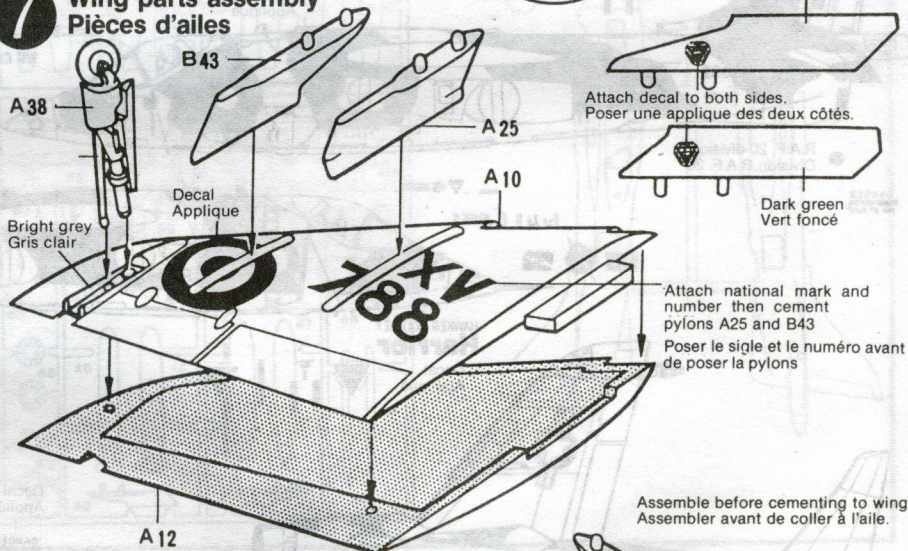

8 Wing assembly — Ailes

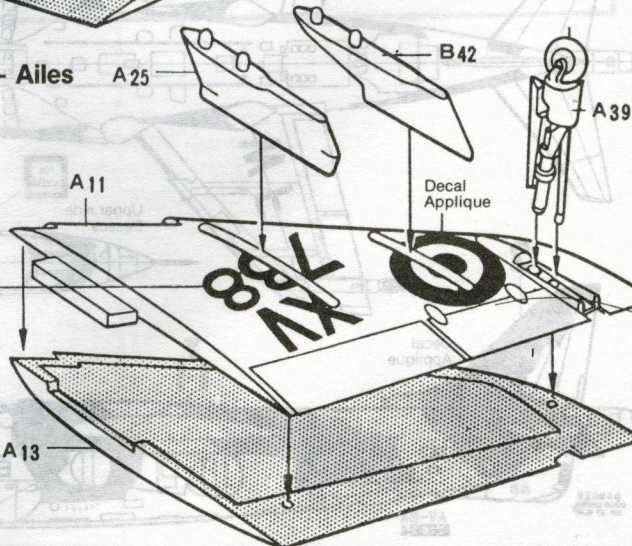

11 (Airframe assembly/Accessoires de vol)

Cement horizontal stabilizers with care so they can be operated.
Coller les ailerons avec soin pour qu'ils puissent s'orienter.

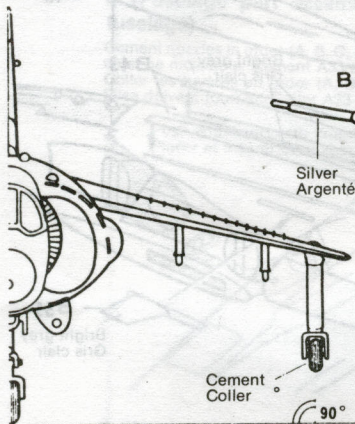

12 (Equipment assembly/Équipement)

Rocket bomb and pod — black inside
Rocquette et support — intérieur noir

Carryall — How to use center pylon
Porte-tout — Utiliser le pylon central

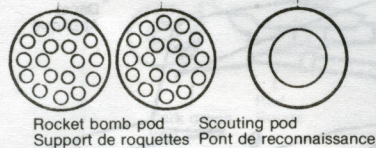
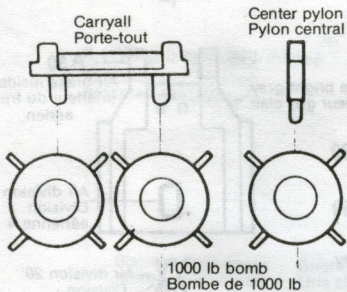

Equipment painting
Peinture de l'équipement

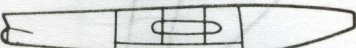

Dark grey
Gris foncé

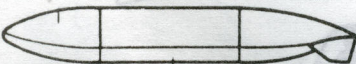

Bright grey
Gris clair

Black
Noir

White
Blanc

Dark grey
Gris foncé

Bright grey
Gris clair

11 Airframe assembly — Accessoires de vol

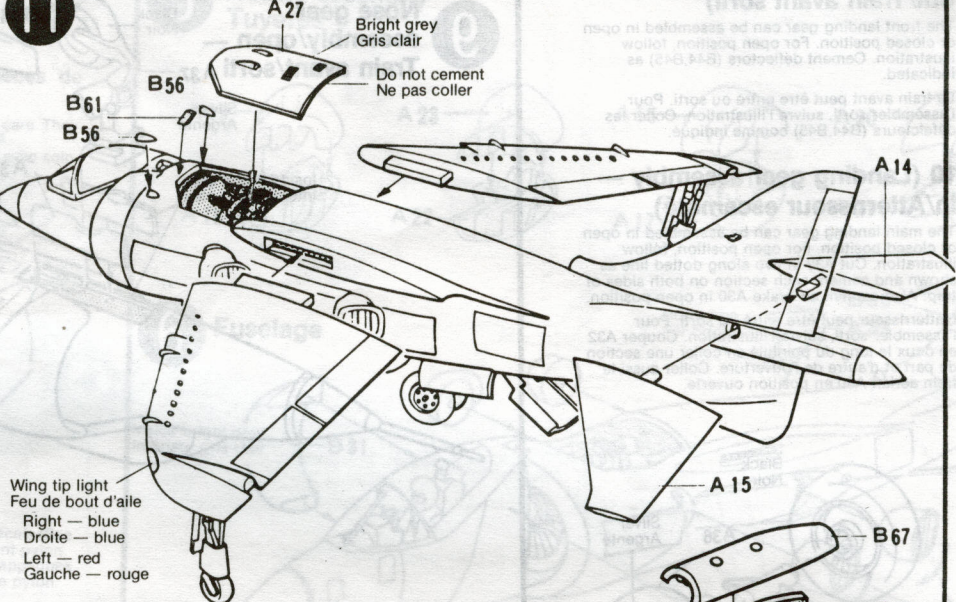

12 Equipment assembly — Équipement

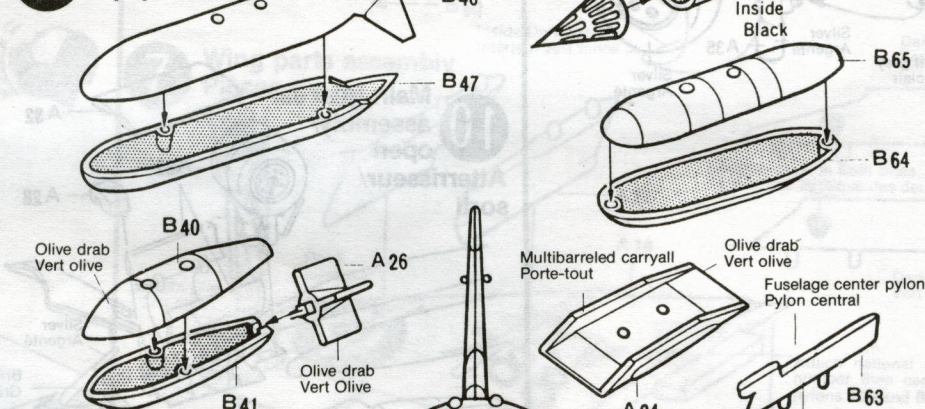

13 Attaching equipment — Fixation de l'équipement

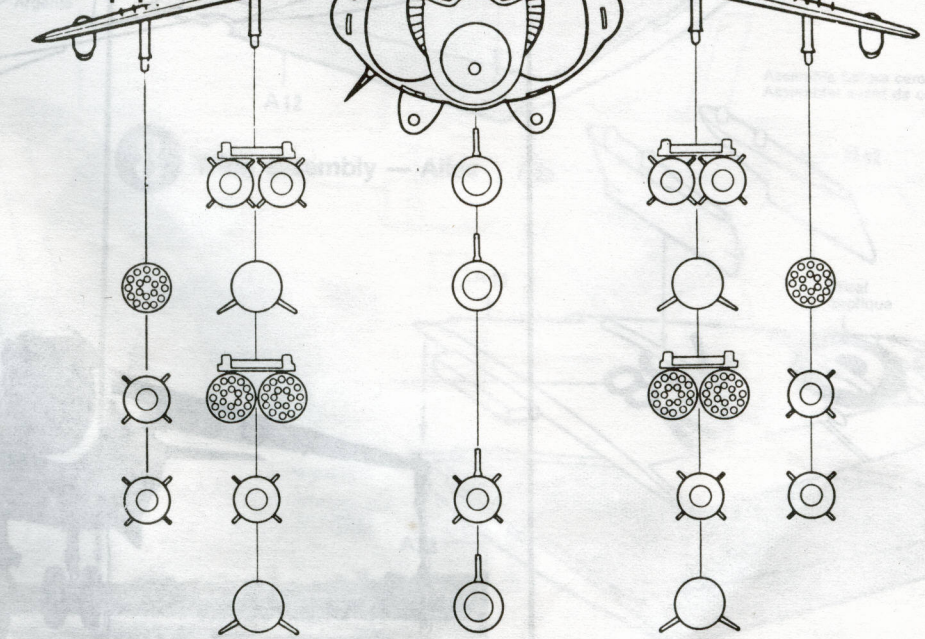

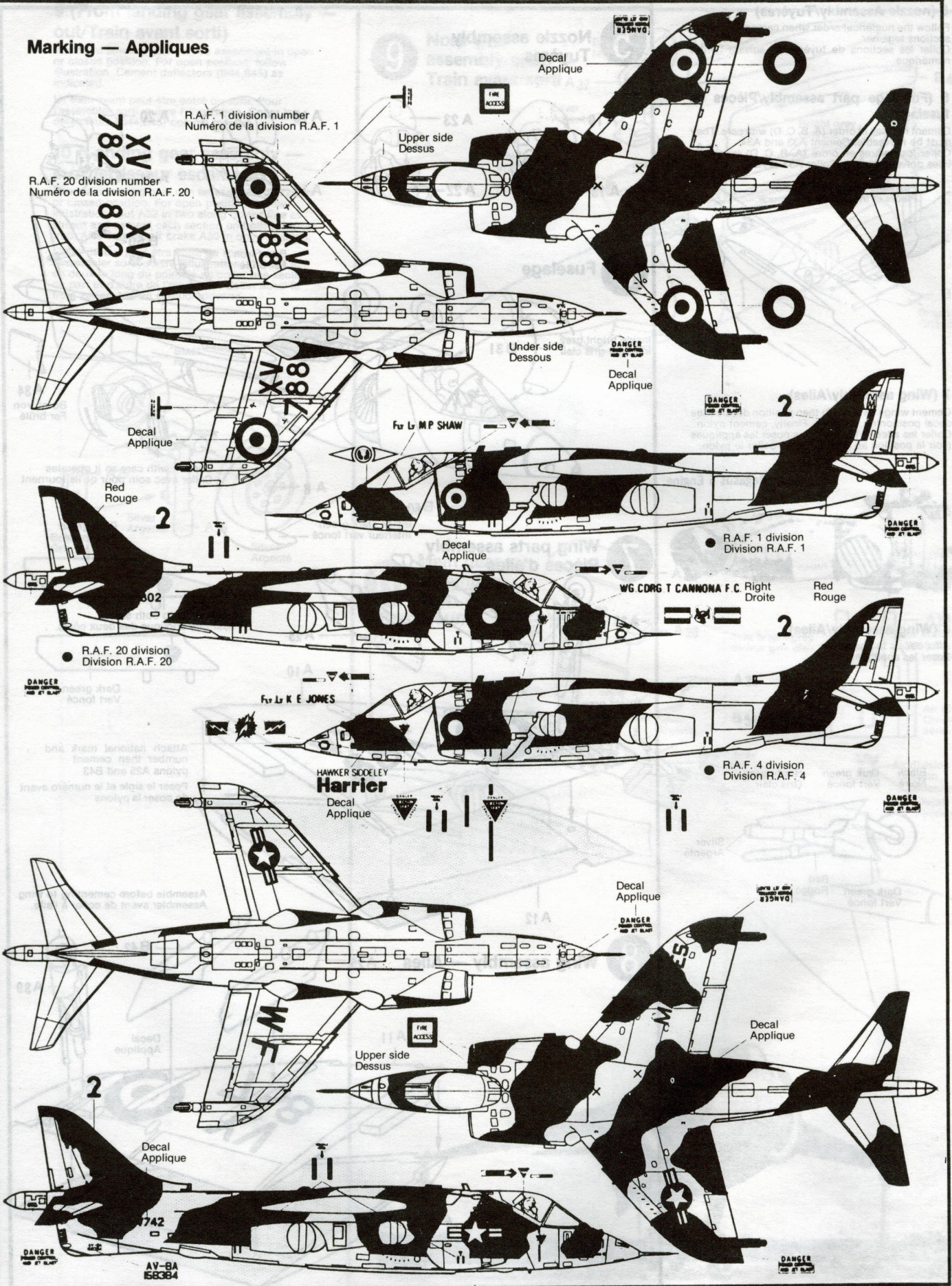

Marking — Appliques



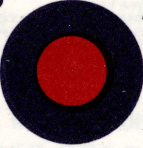

XV 788  XV 788

XV788      XV788

XV 782  D  D  XX D XV 782

XV XX     XX

802  U.S. AIR FORCE U.S. NAVY  802

 WF MARINES WF 

WF XV782 XV742  XV782 XV742 12 MARINES 12 MARINES 158384 158384