

LVT-(A)1 AMTANK

Die ersten ab Juli 1941 bei den US Marines zulaufenden LVT-1 wurden bei den amphibious tractor battalions eingesetzt und von den Soldaten sehr schnell mit dem Spitznamen „Amtrac“; versehen. Die erste Bewährungsprobe für die Landing Vehicles, Tracked (Landungsfahrzeuge, mit Kettenlaufwerk) erfolgte im August 1942 bei der Landung auf Guadalcanal, wo die ungepanzerten Fahrzeuge allerdings ausschließlich für Nachschubtransporte eingesetzt wurden. Die Folgeentwicklung des LVT-1, das Anfang 1943 eingeführte LVT-2, war gepanzert und für amphibische Landungsunternehmen vorgesehen. Bei den Einsätzen dieser neuen Fahrzeuge wurde der Bedarf an geeigneten amphibischen Fahrzeugen für eine direkte Feuerunterstützung deutlich, speziell während der ersten Landungsphase. Als Konsequenz entstanden auf Basis des LVT-2 Feuerunterstützungsfahrzeuge, die mit verstärkter Panzerung versehen und mit dem vom leichten Panzer M 5 A1 „Stuart“ stammenden Turm mit einer 37 mm Bordkanone samt koaxialem MG ausgerüstet wurden. Dazu kamen zwei Stände für cal. 30 (7,62 mm) Maschinengewehre. Diese Fahrzeuge erhielten die Bezeichnung LVT(A)-1, wurden ab Dezember 1943 hergestellt und bei den US Marines und der US Army für amphibische Landeoperationen eingesetzt. Das Gefechtsgewicht des 7,95 m langen, 3,25 m breiten und 2,46 m hohen LVT(A)-1 betrug 13.610 kg. Der 250 PS leistende Continental-Motor ermöglichte eine Höchstgeschwindigkeit von 32 km/h auf der Straße. Auch im Wasser sorgten die Ketten für den entsprechenden Vortrieb, hier lag die maximal erreichbare Geschwindigkeit bei 12 km/h. Die Besatzung bestand aus fünf Mann.

LVT-(A)1 AMTANK

The LVT-1s that were first supplied to the US Marines in July 1941 were used by the amphibious tractor battalions and the soldiers very soon gave them the nickname „Amtrac“. The first tests for the „Landing Vehicle, Tracked“ were carried out in August 1942 at the landing on the Guadalcanal, where the unarmoured vehicles were used exclusively for transporting supplies. The further development of the LVT-1, the LVT-2 that was introduced at the beginning of 1943, was armoured and designed for amphibious landings. It was clear that these new vehicles were intended to meet the requirement for a suitable amphibious vehicle to provide direct fire support, particularly during the initial landing phase. Consequently, fire support vehicles were made, based on the LVT-2, but equipped with reinforced armour and with the turret from the M 5 A1 Stuart light tank with a 37 mm cannon and coaxial MG. They also had two mounts for cal.30 (7.62 mm) machine guns. These vehicles, designated LVT(A)-1, were made from December 1943 and used by the US Marines and US Army for amphibious land operations. The combat weight of the 7.95 m long, 3.25 m wide and 2.46 m high LVT(A)-1 was 13,610 kg. The Continental engine that developed 250 hp gave it a maximum road speed of 32 km/h. In the water also the tracks provided sufficient propulsion to give a maximum speed of 12 km/h. It had a five-man crew.

Benötigte Farben / Used Colors

Benötigte Farben
Required coloursPeintures nécessaires
Benodigde kleurenPinturas necesarias
Tintas necessáriasColori necessari
Använda färgerTarvittavat värit
Du trenger følgende fargerNødvendige farger
Необходимые краскиPotrzebne kolory
Απαιτούμενα χρώματαGerekli renkler
Potřebné barvySzükséges színek.
Potrebne barve**A****80 %**

blaugrau, matt 79
greyish blue, matt
gris-bleu, mat
blauwgris, mat
gris azulado, mate
cinzento azulado, fosco
grigio blu, opaco
blågrå, matt
siniharma, himmeä
blågrå, mat
blågrå, matt
син-серый, матовый
sivuy, matowy
γκρίζο μπλε, ματ
mavi gri, mat
modrosedá, matná
fehér, matt
plavo siva, mat

F

silber, metallic 90
silver, metallic
argent, métallique
zilver, metallic
plata, metalizado
prata, metálico
argento, metallico
silver, metallic
hopea, metallikkilto
sølv, metallik
sølv, metallic
серебристый, металлик
srebro, metaliczny
οσημί, μεταλλικό
gümüş, metalik
stříbrná, metaliza
ezüst, metál
srebrna, metalik

B**20 %**

weiß, matt 5
white, matt
blanc, mat
wit, mat
blanco, mate
branco, fosco
blanco, opaco
vit, matt
valkoinen, himmeä
hvid, mat
hvit, matt
Белый, матовый
biały, matowy
λευκό, ματ
beyaz, mat
blå, matná
bela, mat

khakibraun, matt 86
olive brown, matt
brun khaki, mat
khakibruin, mat
caqui, mate
castanho caqui, fosco
marrone caqui, opaco
kaki-brun, matt
khakiruokaa, himmeä
khakibrun, mat
khakibrun, matt
коричневый "хаки", матовый
brązowy khaki, matowy
καφέ-χακί, ματ
håki renkil, mat
hnědá khaki, matná
kekibarna, matt
kaki jawa, mat

C

anthrazit, matt 9
anthracite grey, matt
anthracite, mat
antraciet, mat
antracita, mate
antracite, fosco
antracite, opaco
antracit, matt
antrasiitti, himmeä
koksgrå, mat
antracit, matt
антрацит, матовый
antracyt, matowy
ανθρακί, ματ
antrasit, matná
antracit, matt
tanmo siva, mat

D**80 %**

rost, matt 83
rust, matt
rouille, mat
roest, mat
orin, mate
ferrogem, fosco
color ruggine, opaco
rost, matt
ruoste, himmeä
rust, mat
rust, matt
ржавчина, матовый
rdzawy, matowy
χρώμα οκουριάς, ματ
ras rengi, mat
rezavá, matná
rozszda, matt
rjawa, mat

+

20 %

eisen, metallic 91
steel, metallic
coloris fer, métallique
ijzerkleurig, metallic
ferroso, metalizado
ferro, metálico
ferro, metallico
järnfärg, metallic
teräksenvärinen, metallikkilto
jern, metallik
jern, metallic
стальной, металлик
żelazo, metaliczny
σιδηρού, μεταλλικό
demir, metalik
železná, metaliza
vas, metál
železna, metalik

E**50 %**

schwarz, seidenmatt 302
black, silky-matt
noir, satiné mat
zwart, zijdelmat
negro, mate seda
preto, fosco sedoso
fiero, opaco seta
svart, sidenmatt
musta, silkkihimmeä
sort, silkematt
черный, шелковисто-матовый
czarny, jedwabisto-matowy
μαύρο, μεταξωτό ματ
siyah, ipek mat
černá, hedvábně matná
fekete, selyemmatt
črna, svila mat

50 %

silber, metallic 90
silver, metallic
argent, métallique
zilver, metallic
plata, metalizado
prata, metálico
argento, metallico
silver, metallic
hopea, metallikkilto
sølv, metallik
sølv, metallic
серебристый, металлик
srebro, metaliczny
οσημί, μεταλλικό
gümüş, metalik
stříbrná, metaliza
ezüst, metál
srebrna, metalik

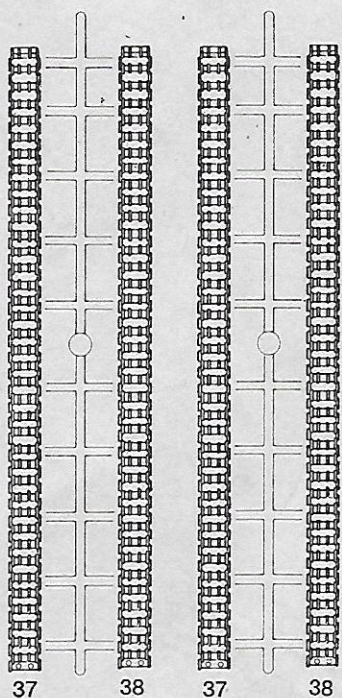
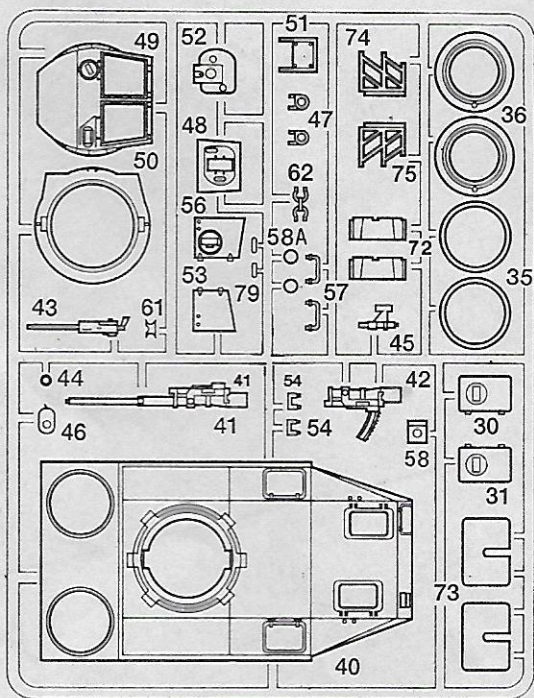
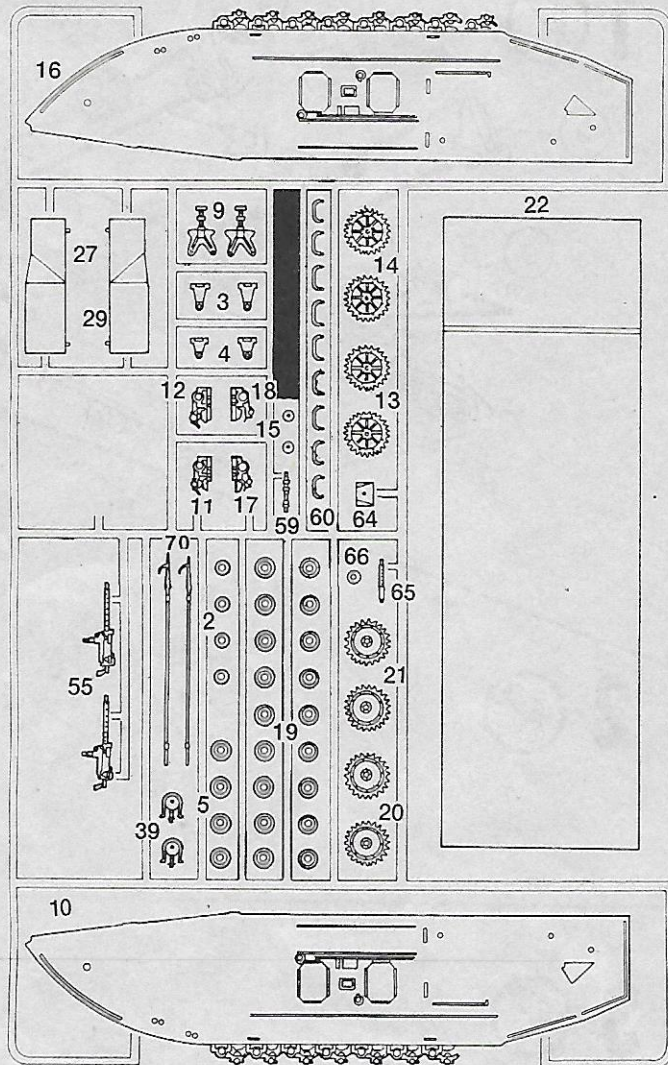
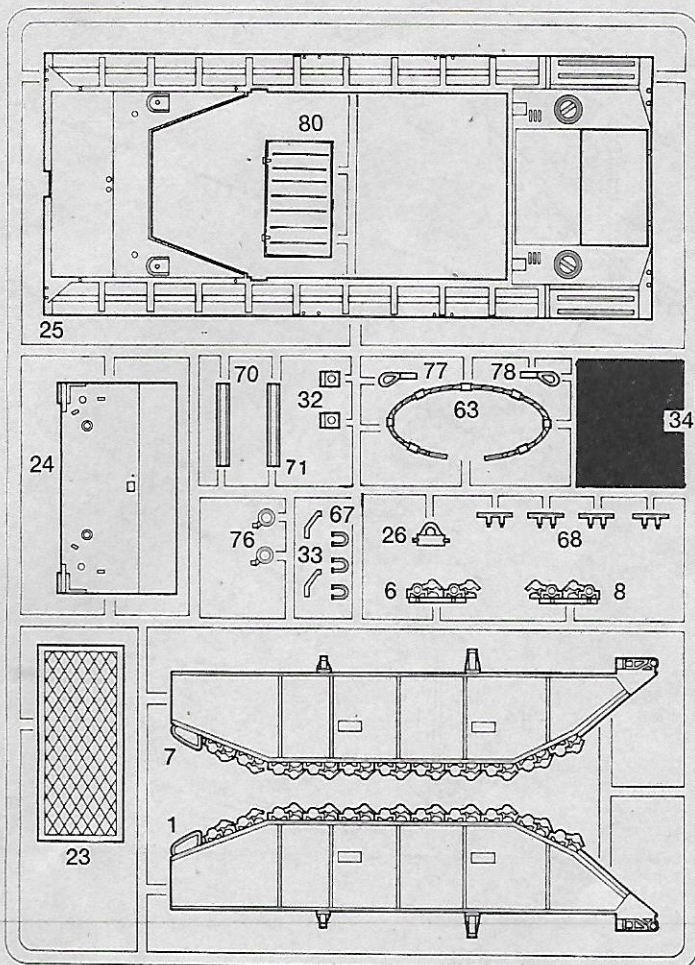

Nicht benötigte Teile
 Parts not used
 Pièces non utilisées
 Niet benodigde onderdelen
 Piezas no necesarias
 Peças não utilizadas
 Parti non usate
 Inte använda delar
 Tarpeettomat osat
 Ikke nødvendige dele
 Deler som ikke er nødvendige
 Неиспользованные детали
 Elementy niepotrzebne
 μη χρειαζόμενα εξαρτήματα
 Gereksiz parçalar
 Nepotrebné díly
 fel nem használt alkatrészek
 Nepotrebni deli

1 

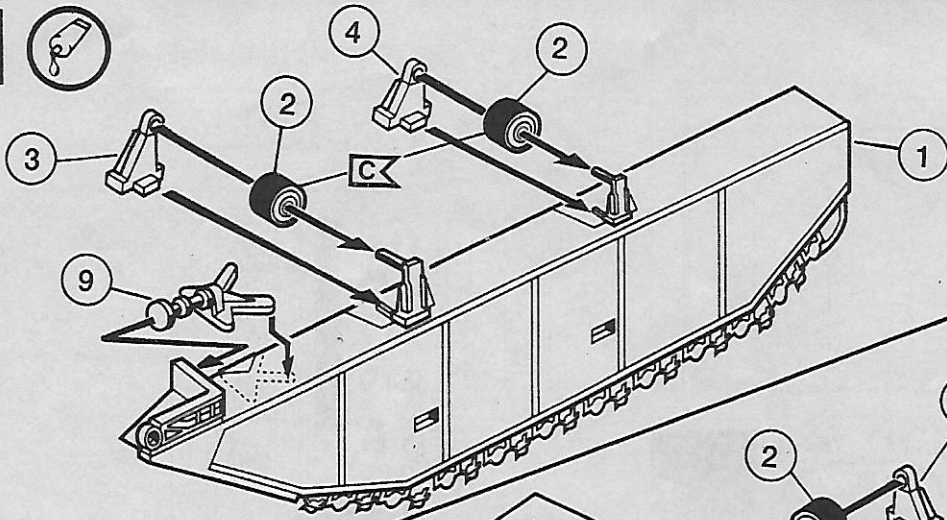

2 

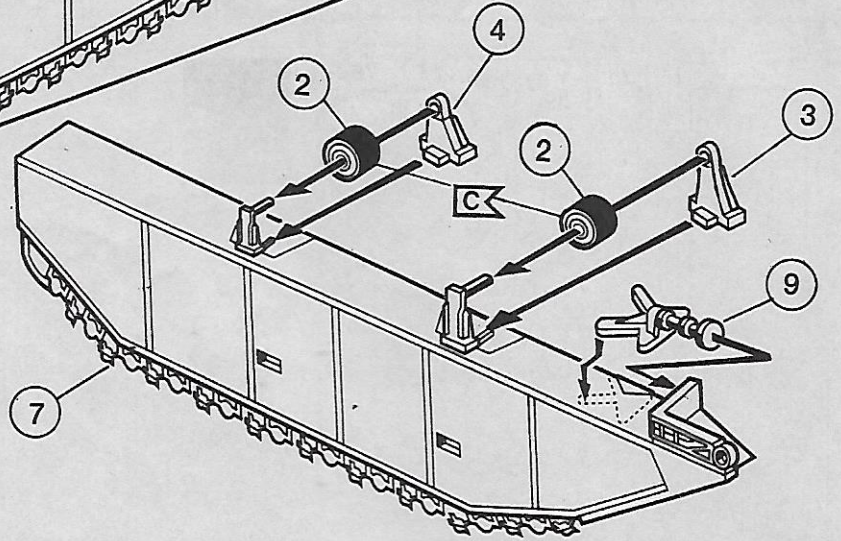

3 

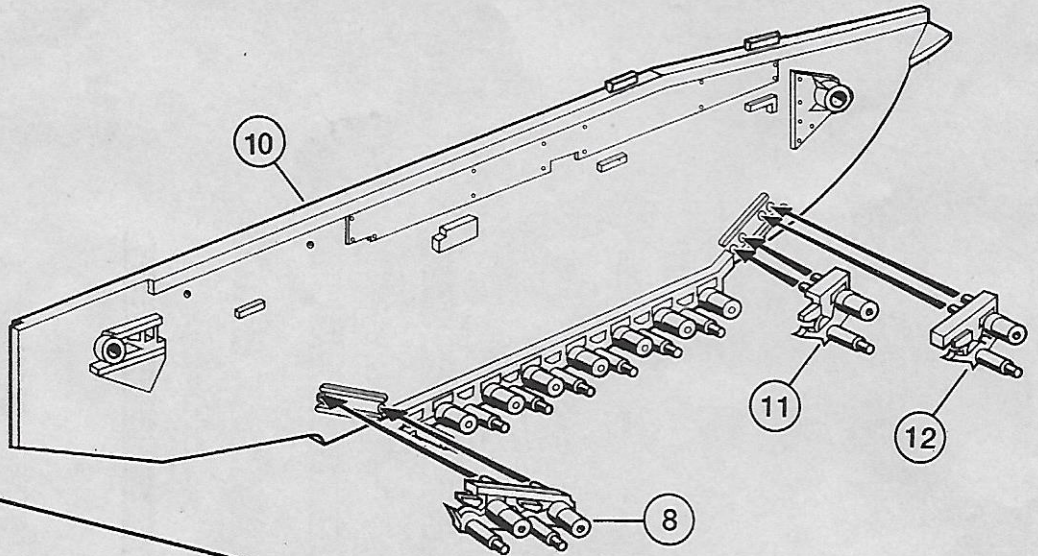

4 

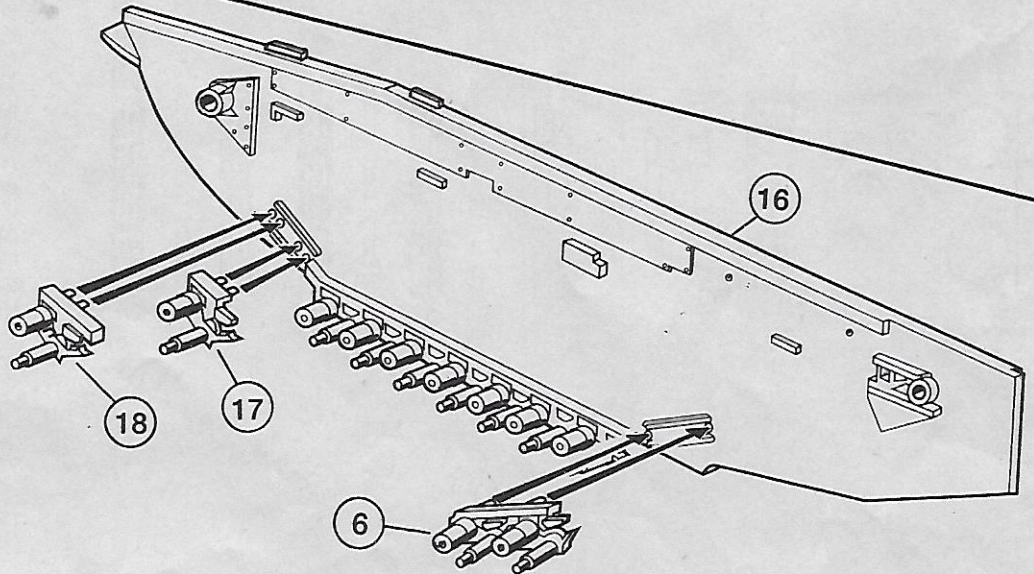

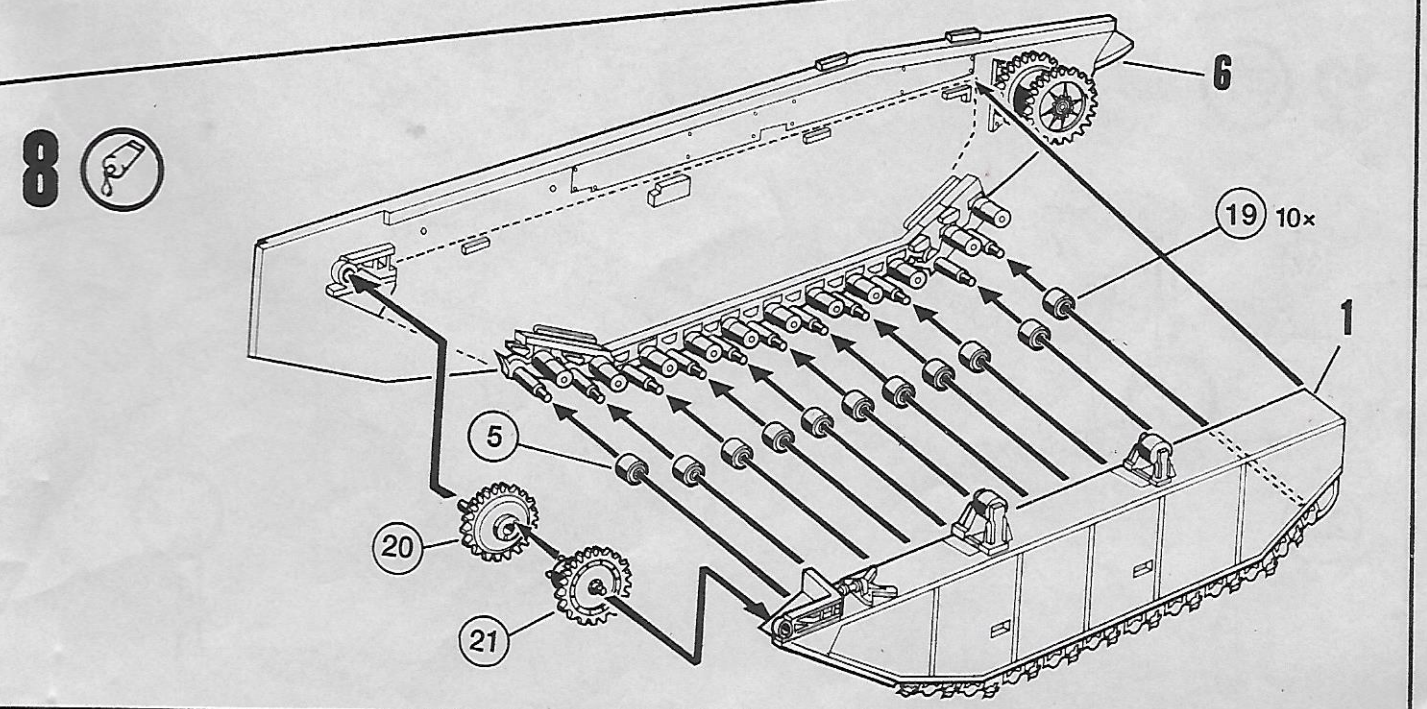
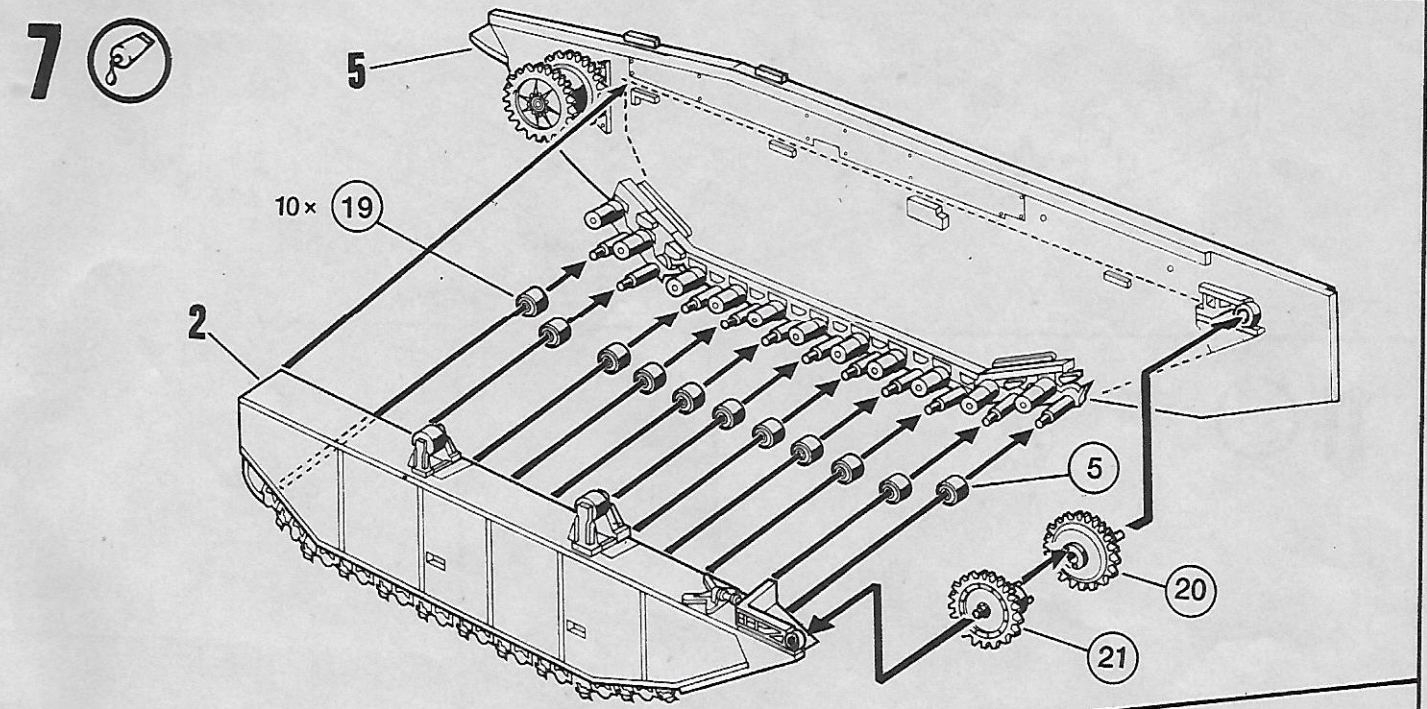
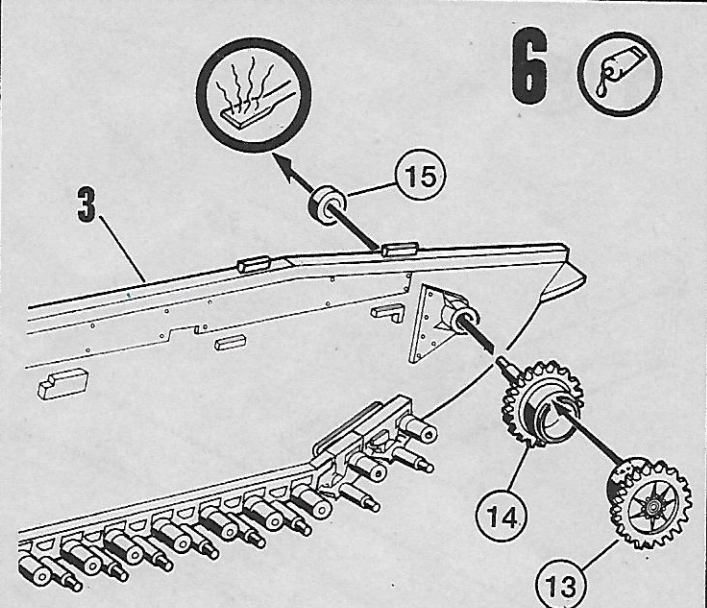
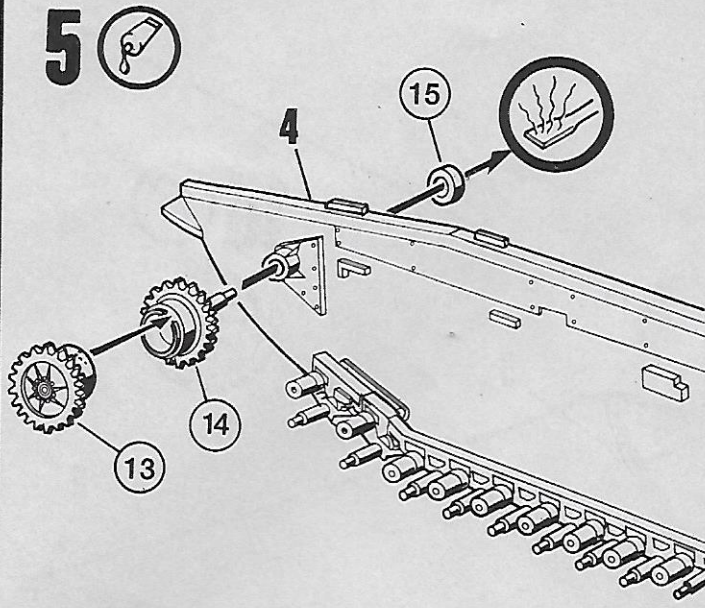

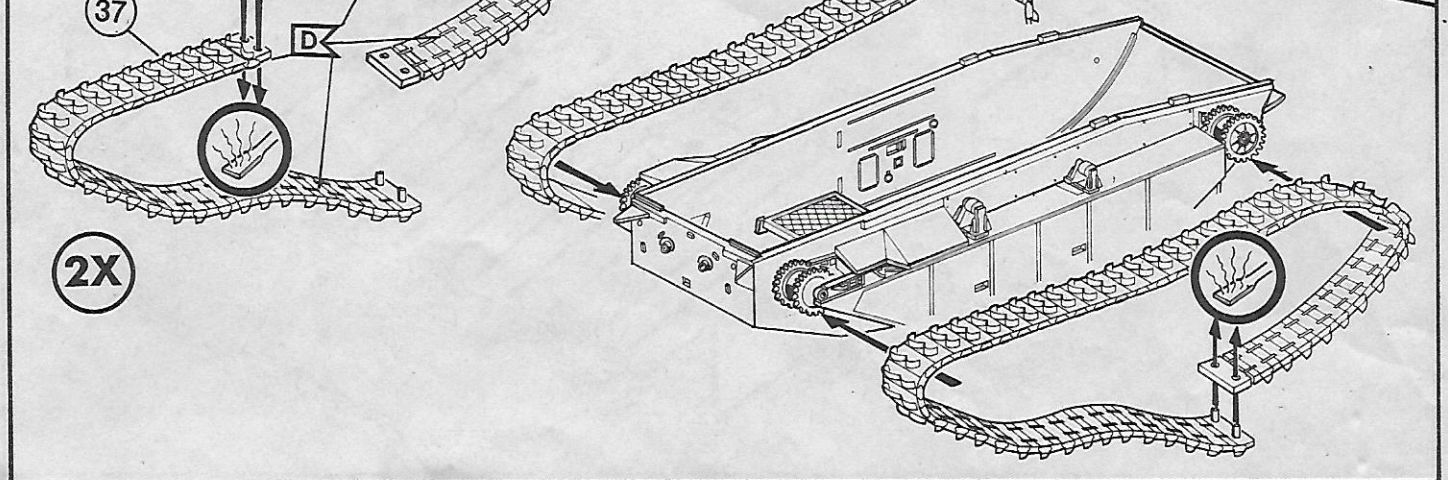
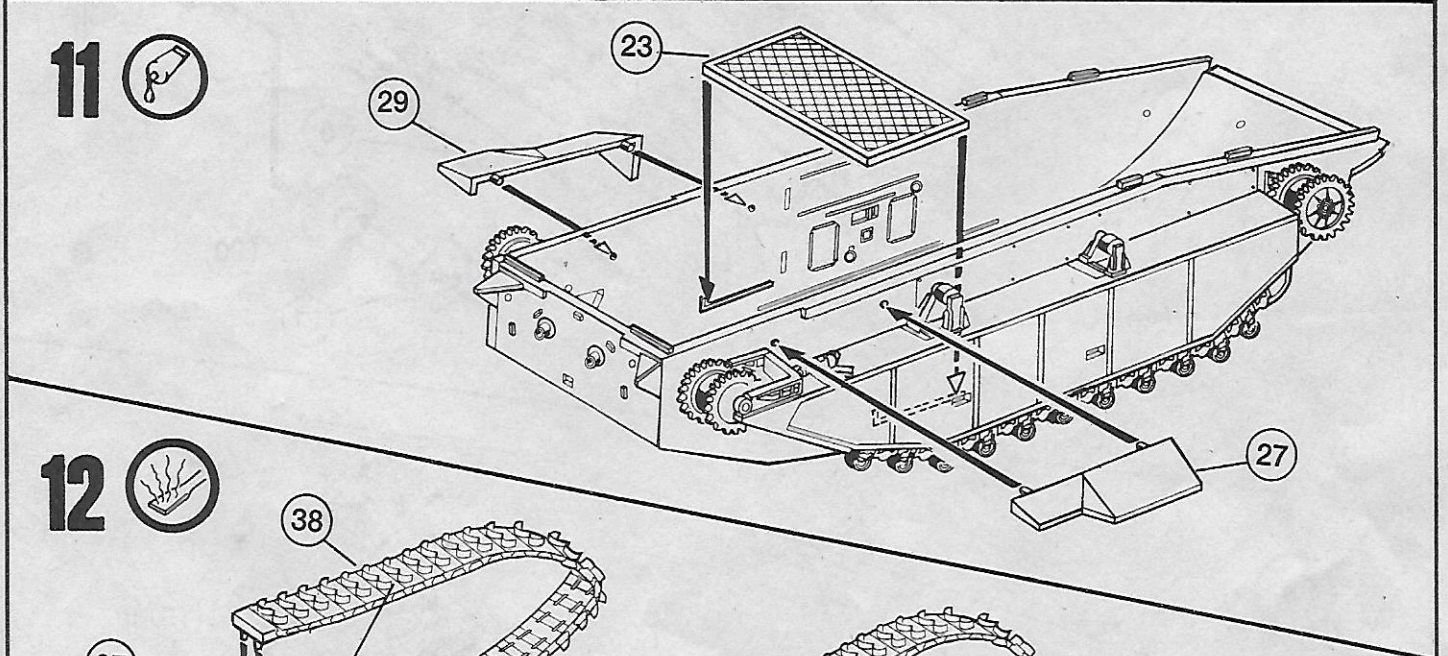
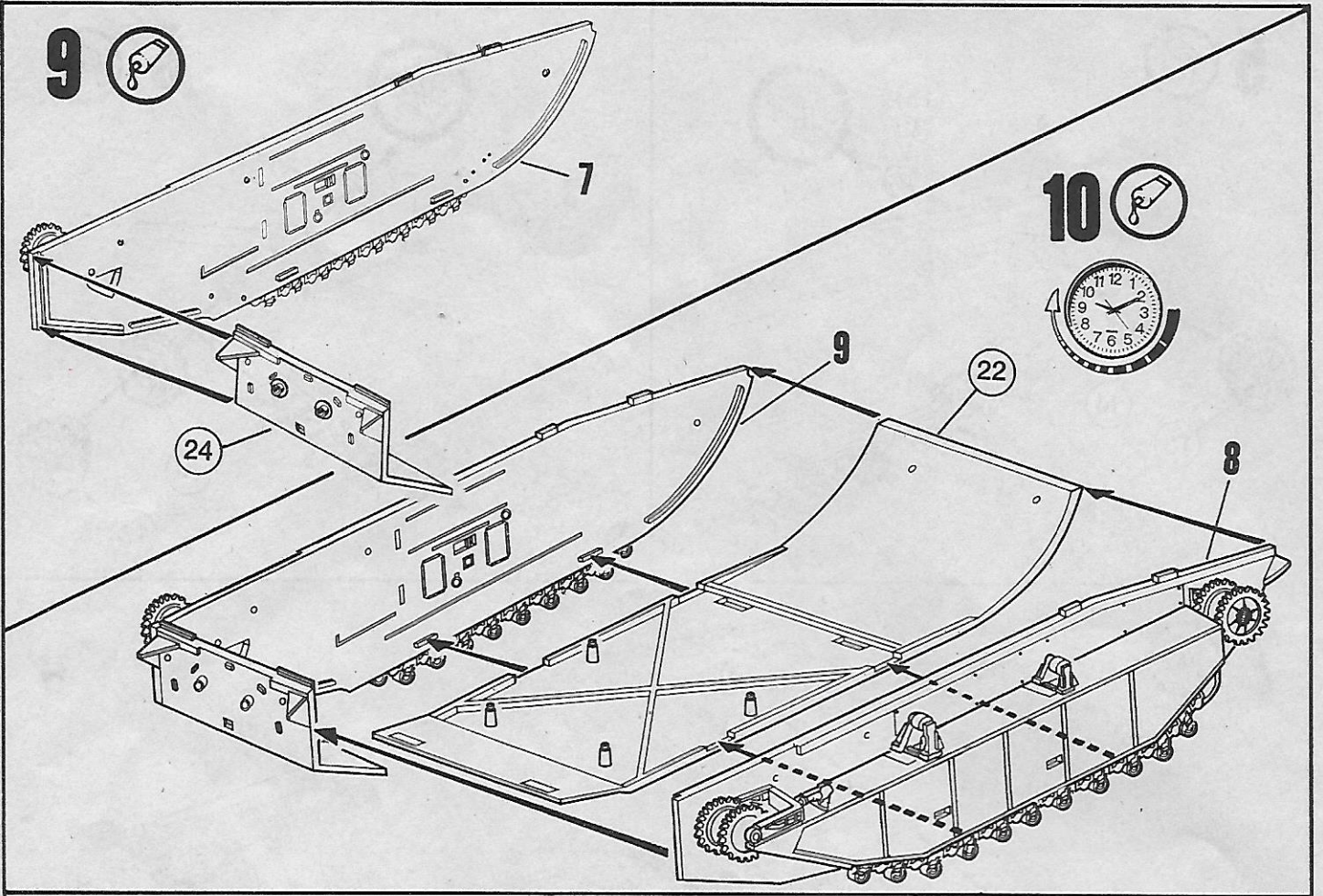

13 

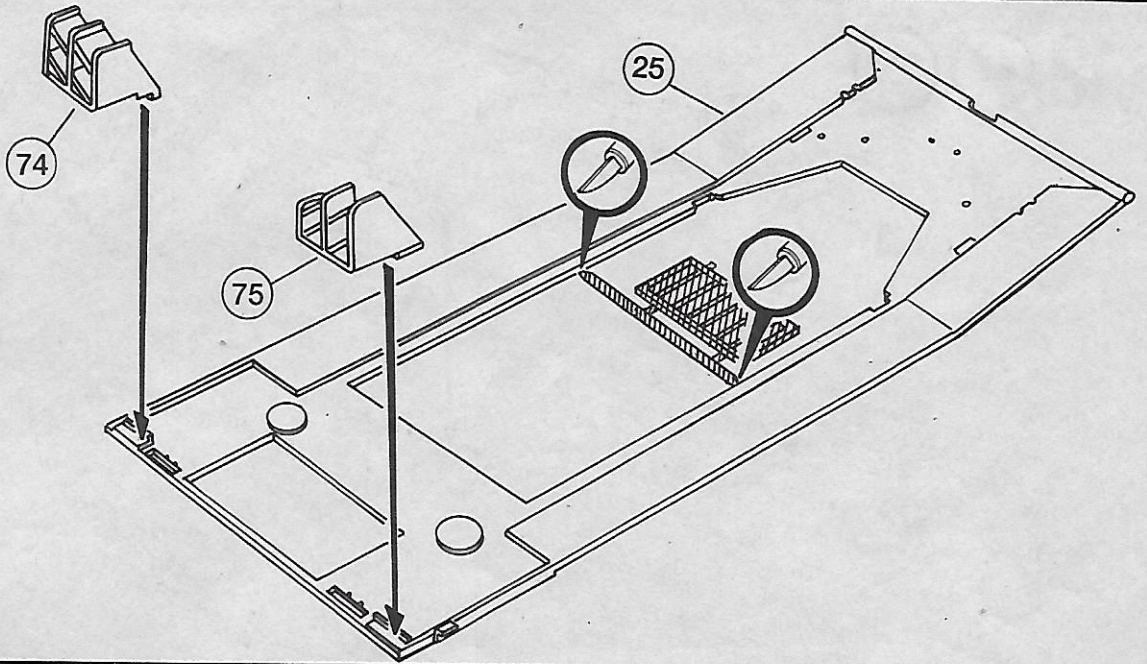

14 

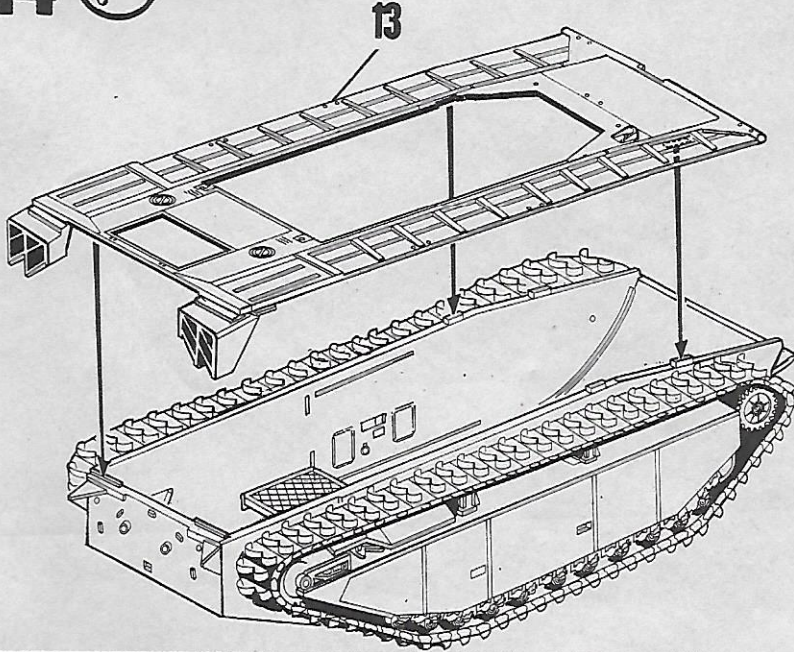

15 

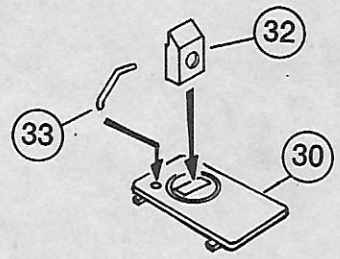

16 

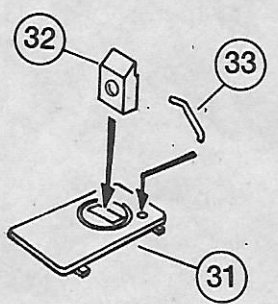

17  

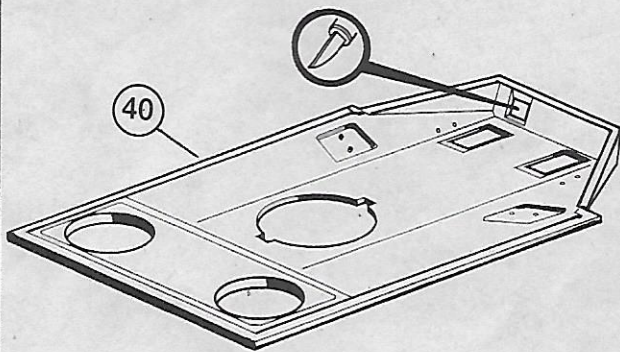

18 

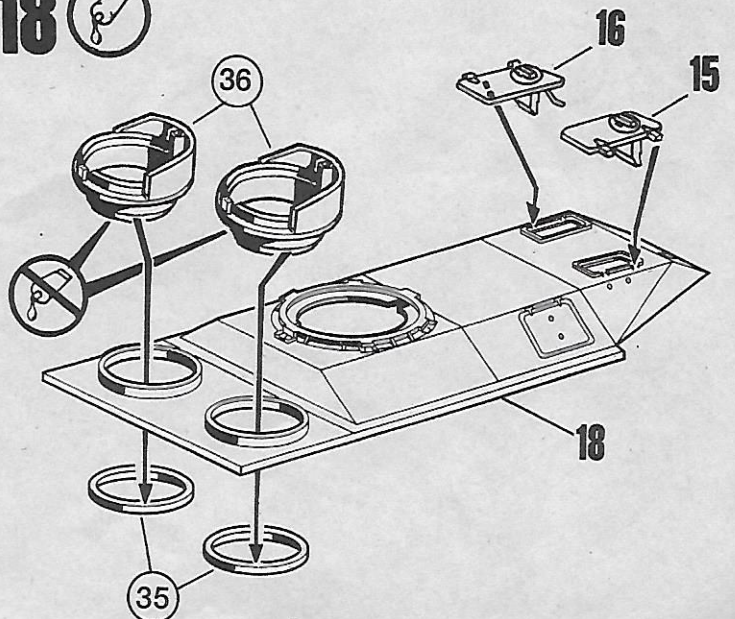

19

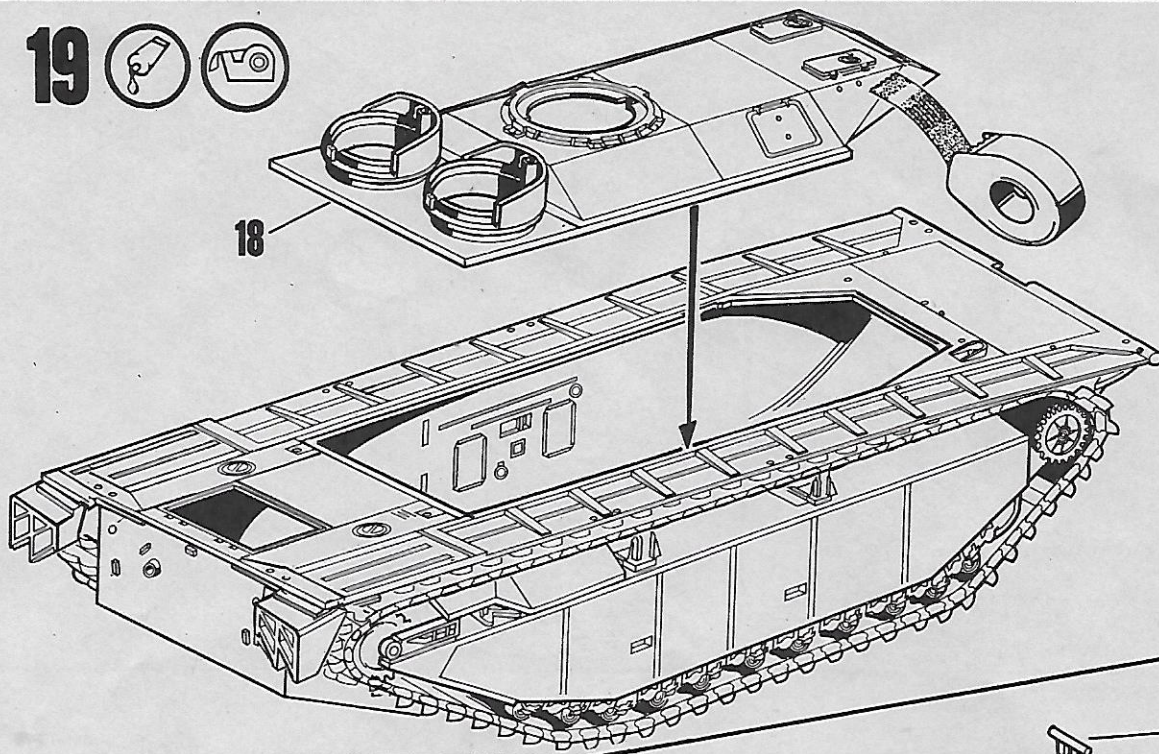

20

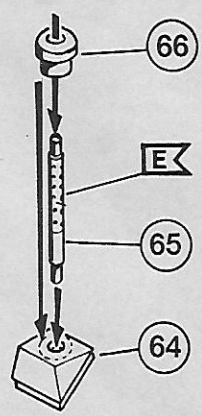

21

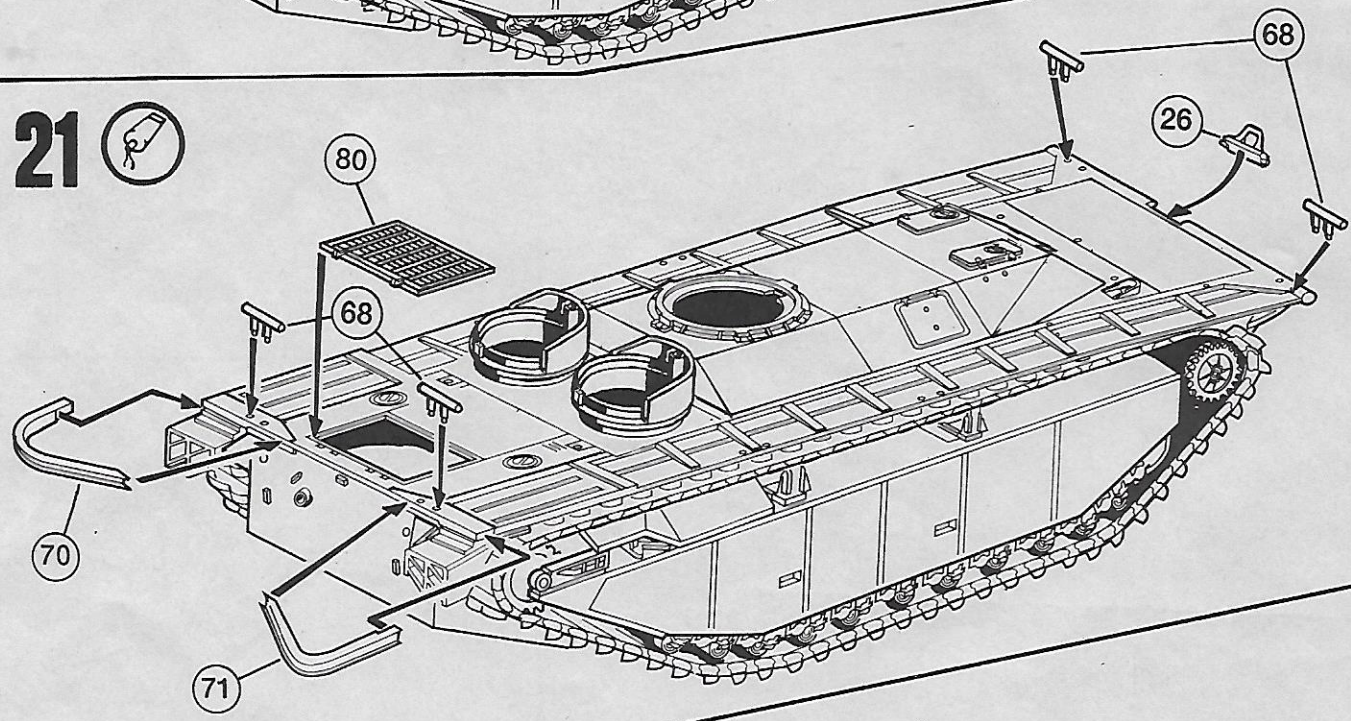

22

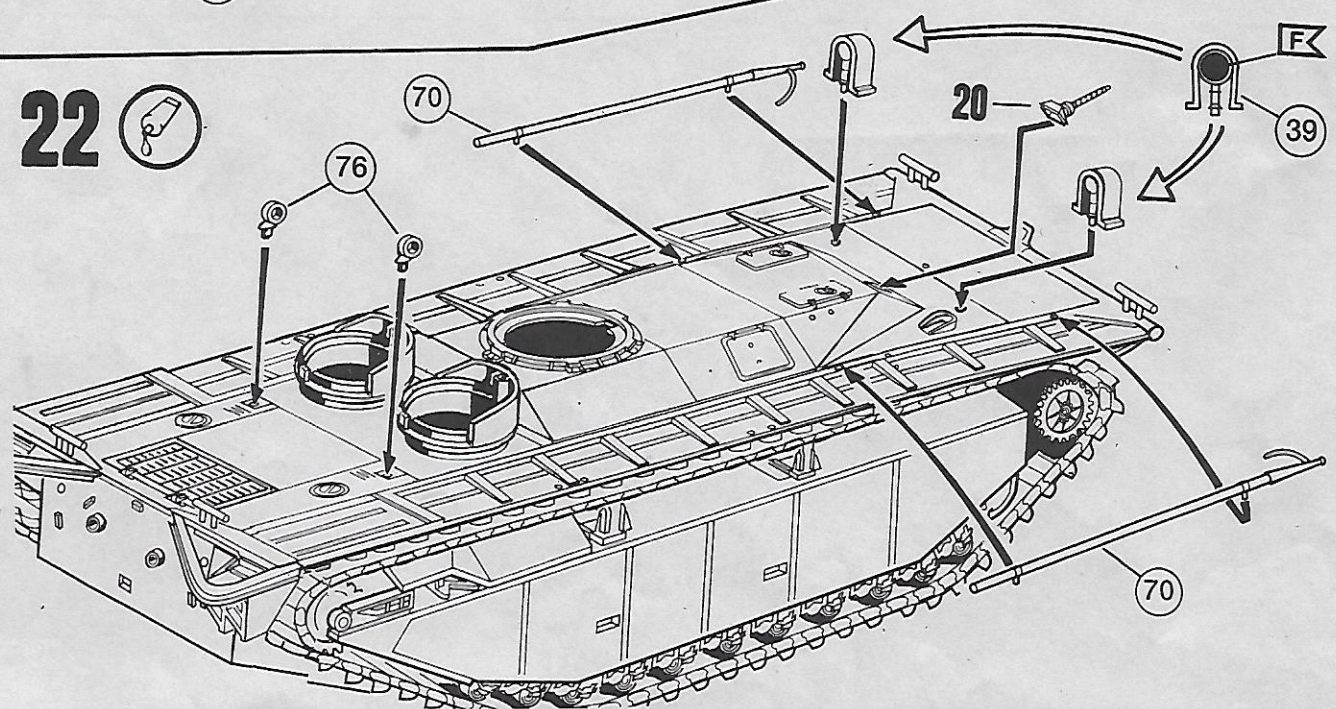

23

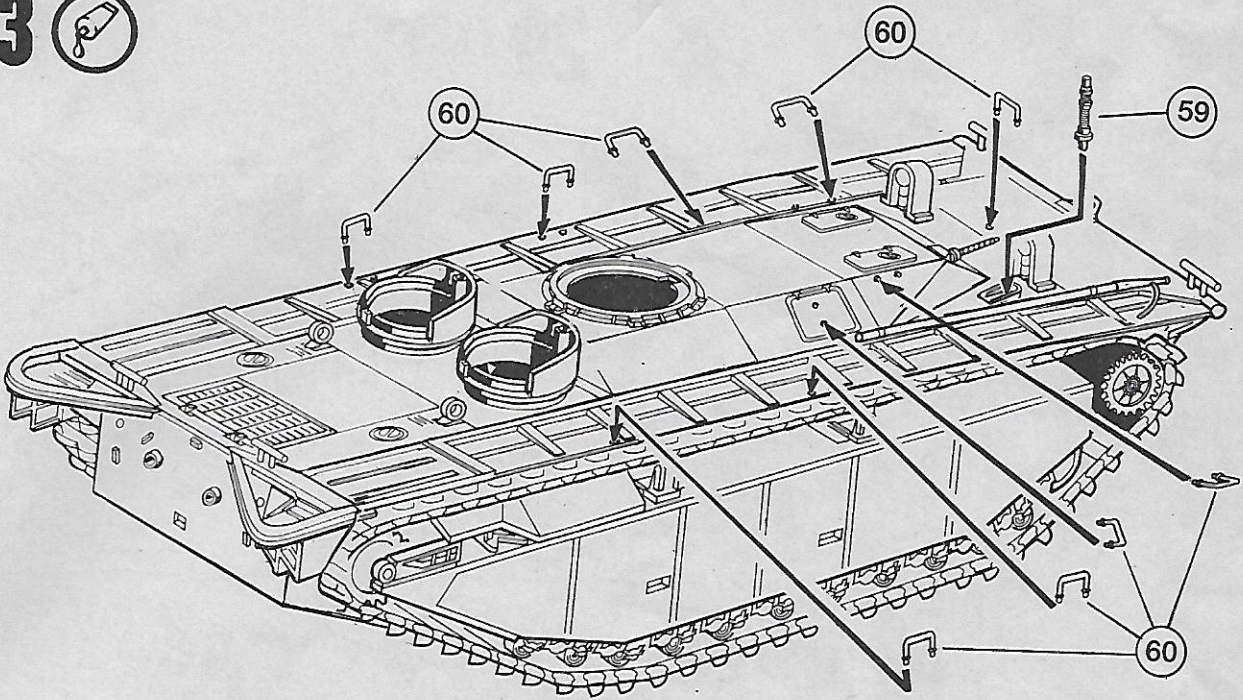

24

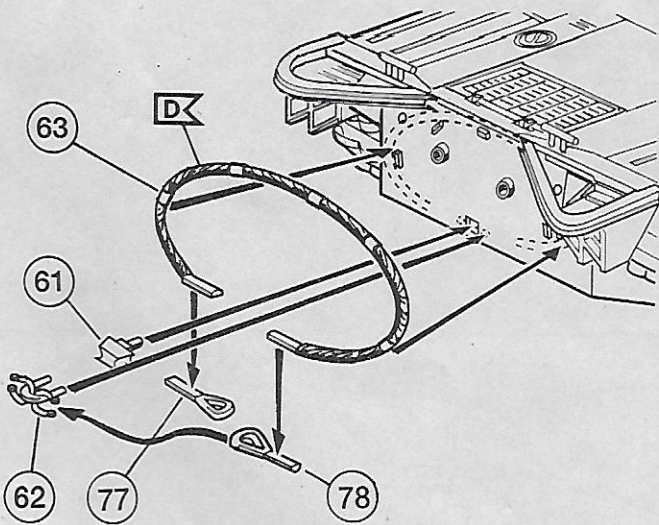

25

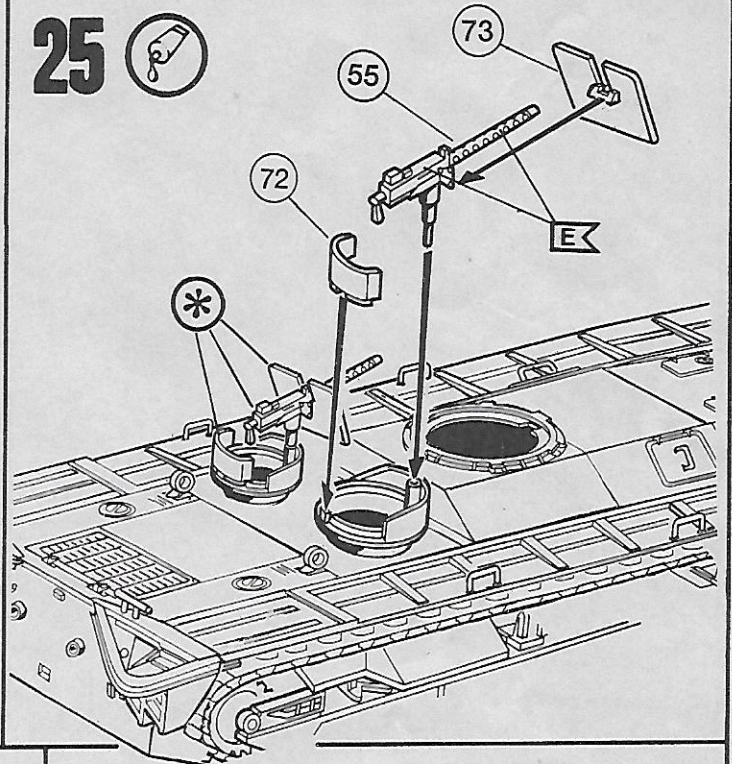

26

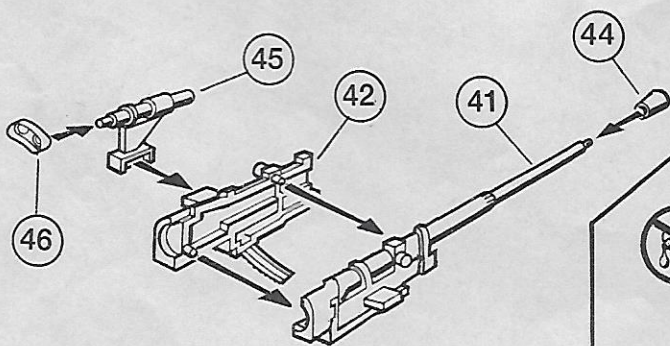

27

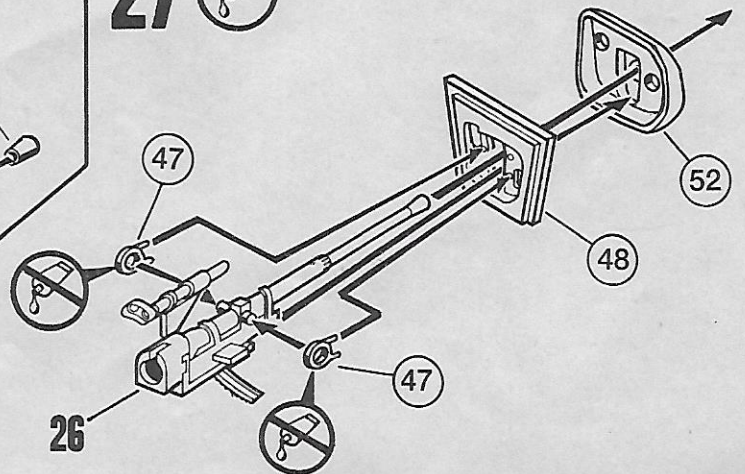

28

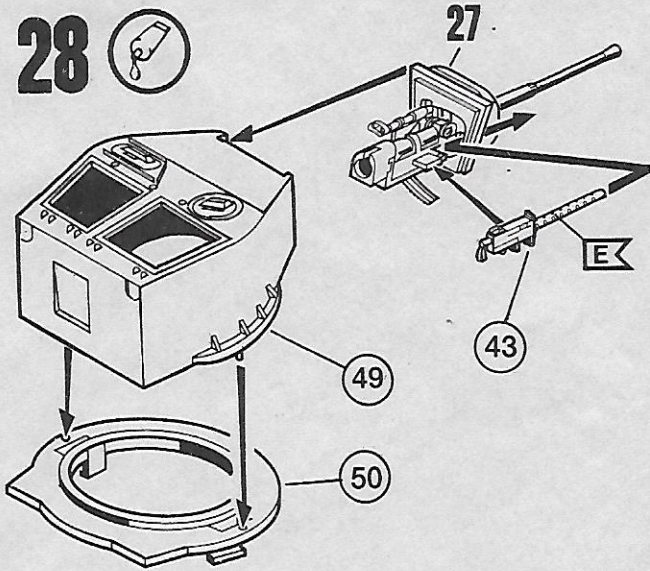

29

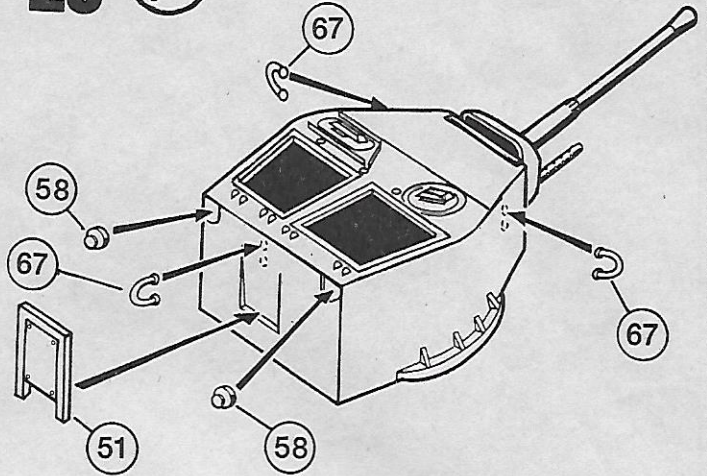

30

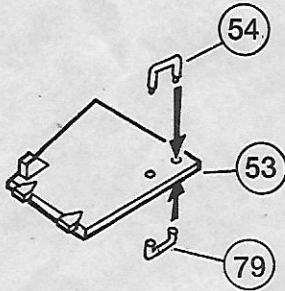

32

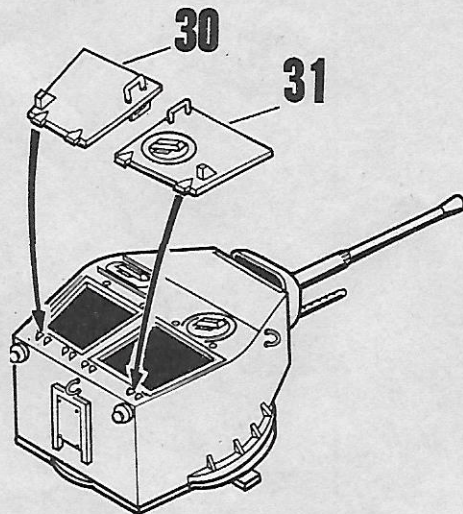

33

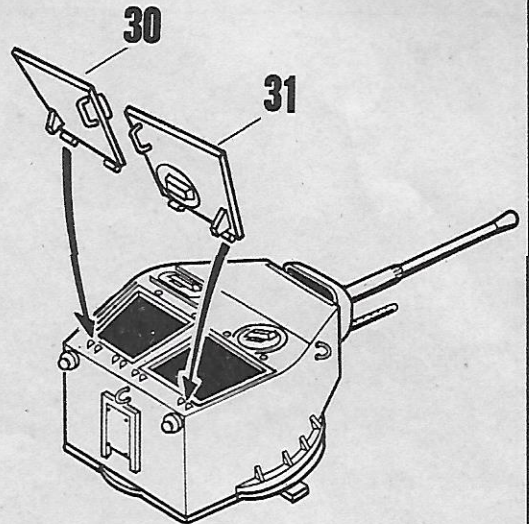

31

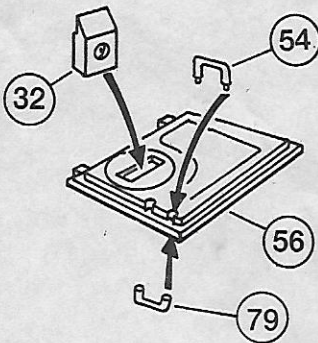

32-33

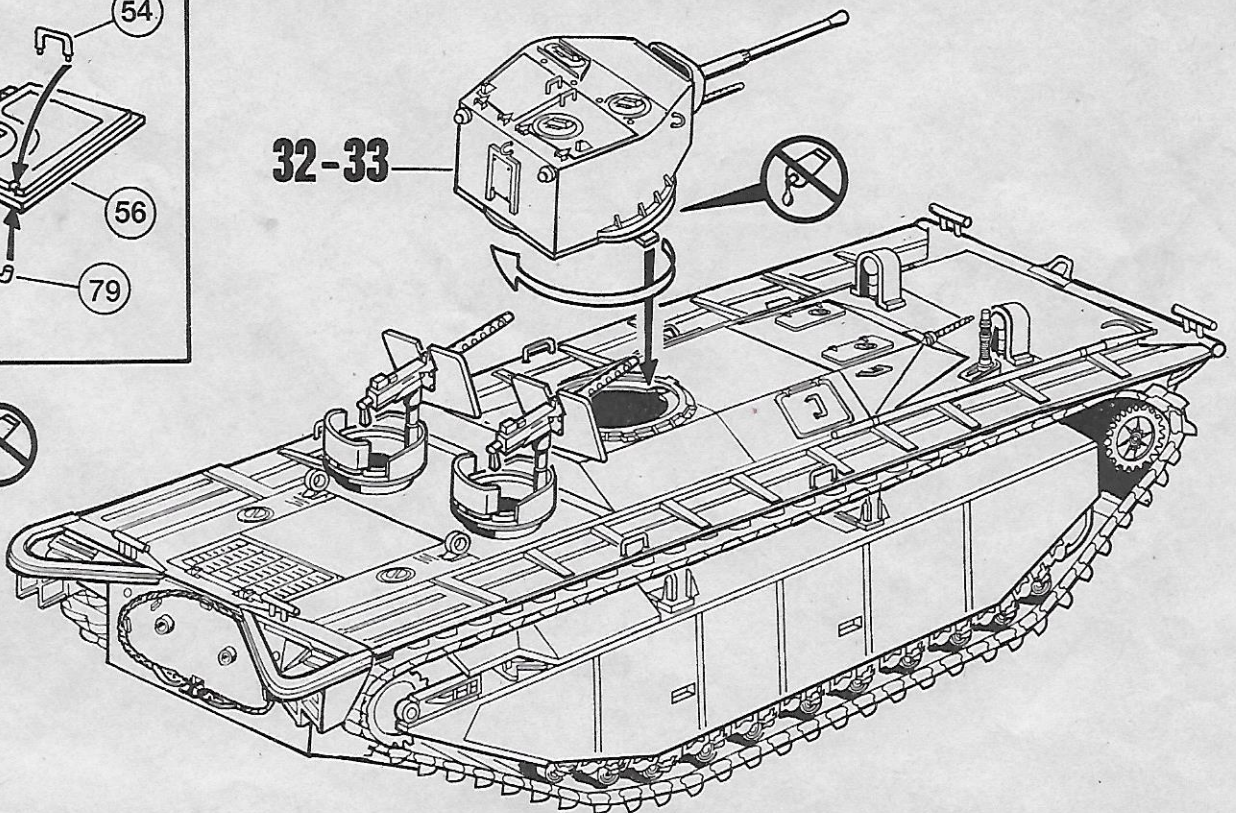

34



35



1st Amphibious Assault Battalion
1st Marine Division, Anfang 1944

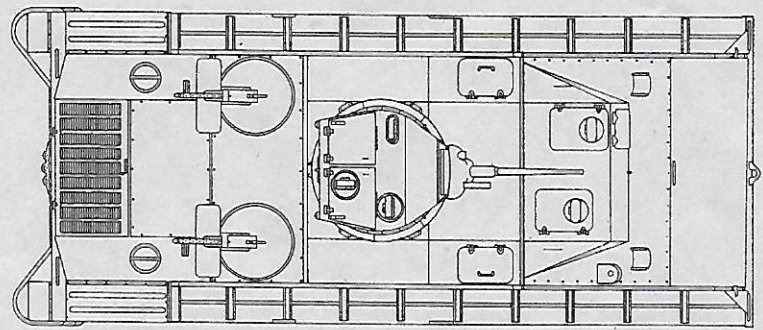
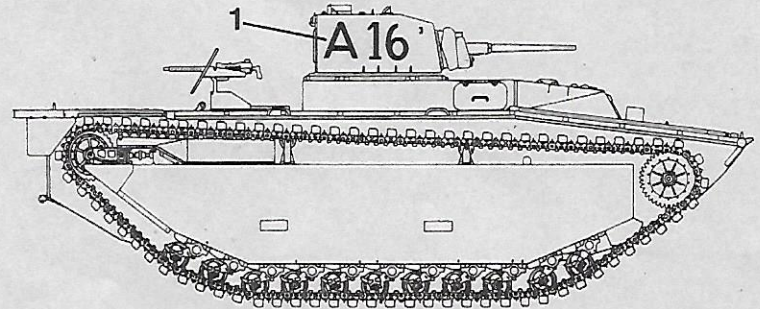
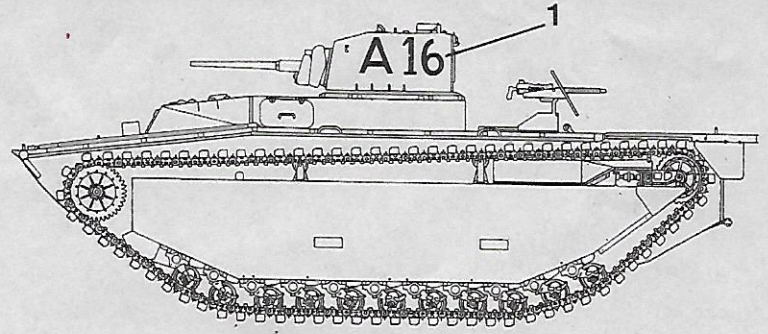
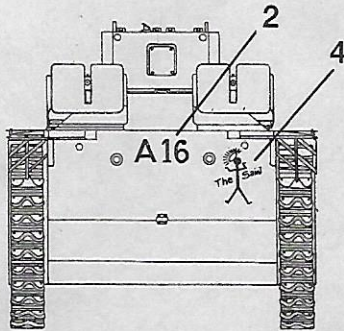
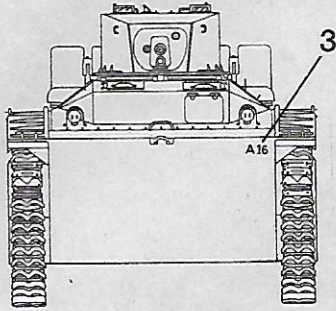
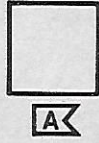

36



C-Company
708th Amphibious Tank Battalion
Saipan, Juni 1944

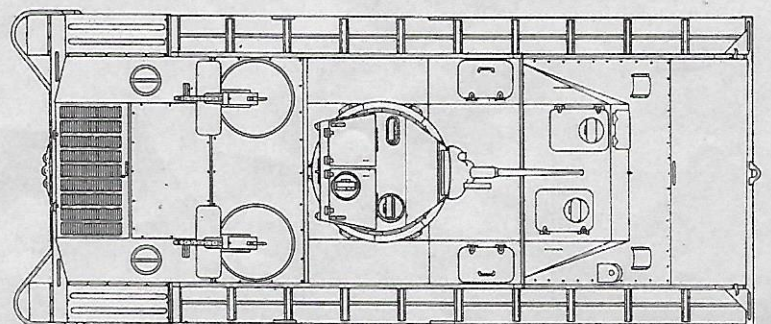
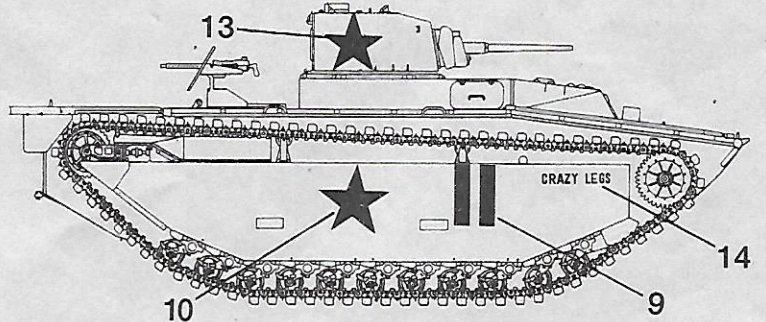
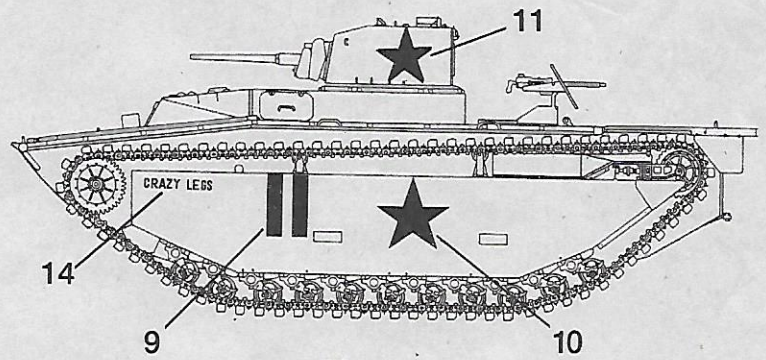
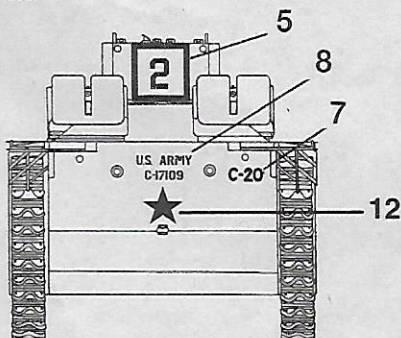
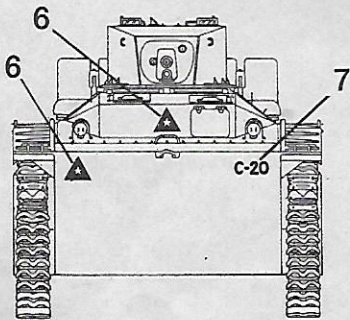

37



3rd Marine Armored
Amphibious Battalion
Peleliu, Sept. 1944



B

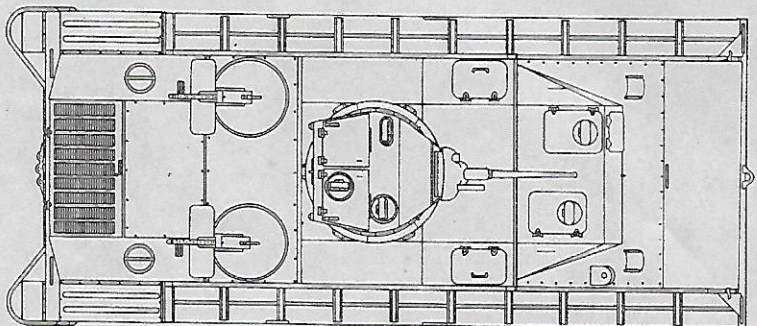
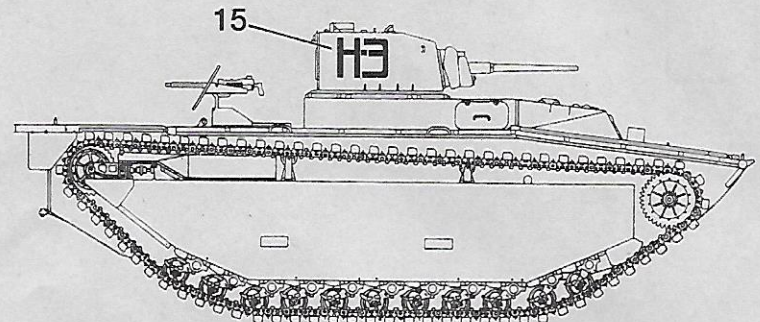
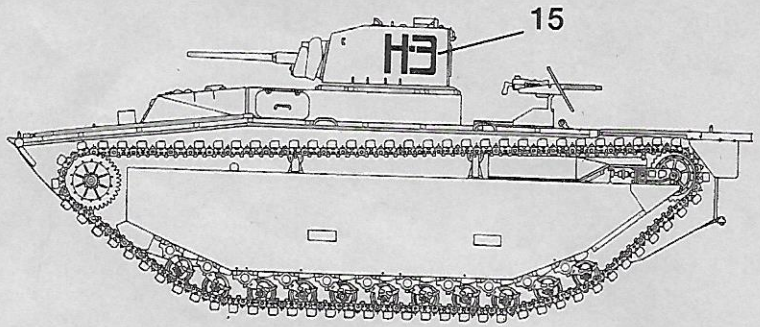
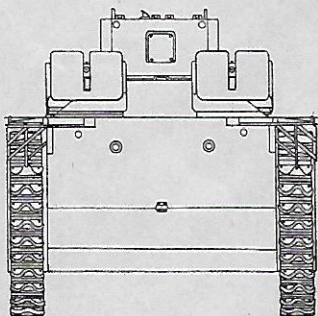
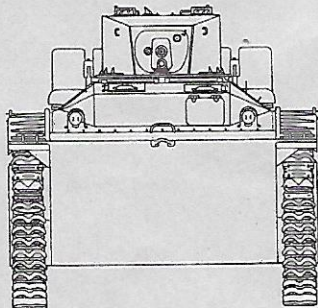

38



B-Company
708th Amphibious Battalion
Saipan, Juni 1944



A

