

StuH 42 Ausf. G

Early Prod. May-June 1943

35349



GENERAL INSTRUCTION

HIGHLY DETAILED PLASTIC MODEL KIT

PHOTO-ETCHED PARTS INCLUDED

INDIVIDUAL TRACKS INCLUDED

CLEAR PLASTIC
PARTS INCLUDED

ALL HATCHES CAN BE ASSEMBLED
IN OPEN OR CLOSED POSITION

METAL SURFACES AND WELD LINES
ACCURATELY REPRESENTED IN THE MODEL

DECAL SHEET FOR 5 OPTIONS

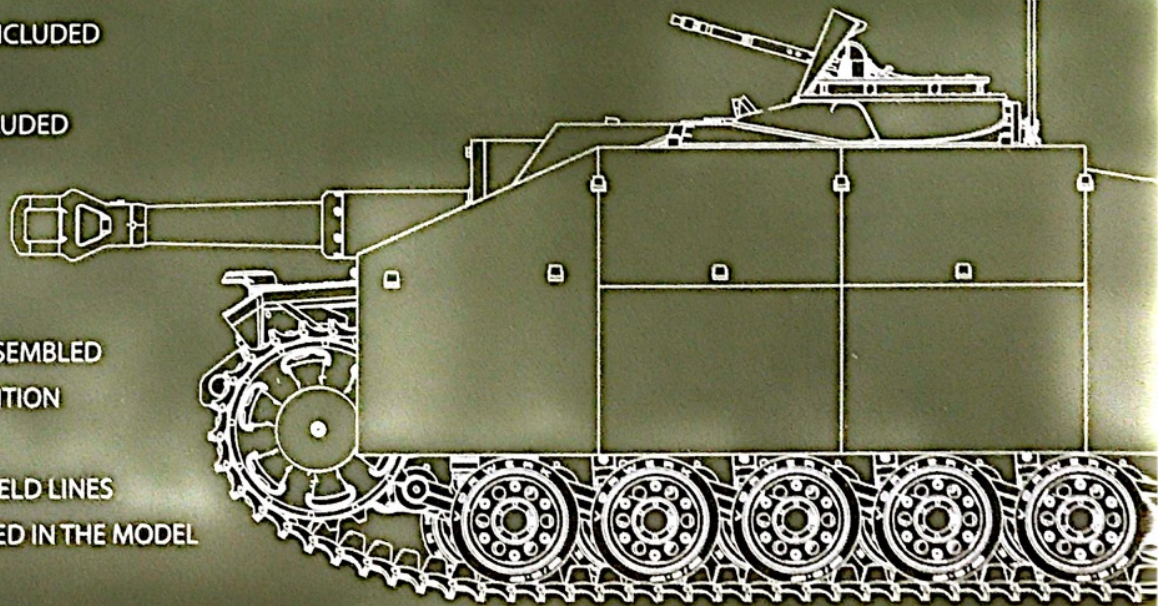

SCALE
1:35



StuH 42 Ausf. G

Early Prod.
May-June 1943

SCALE

1:35

1 StuG. Abt. 912 . Jüterborg, May 1943.

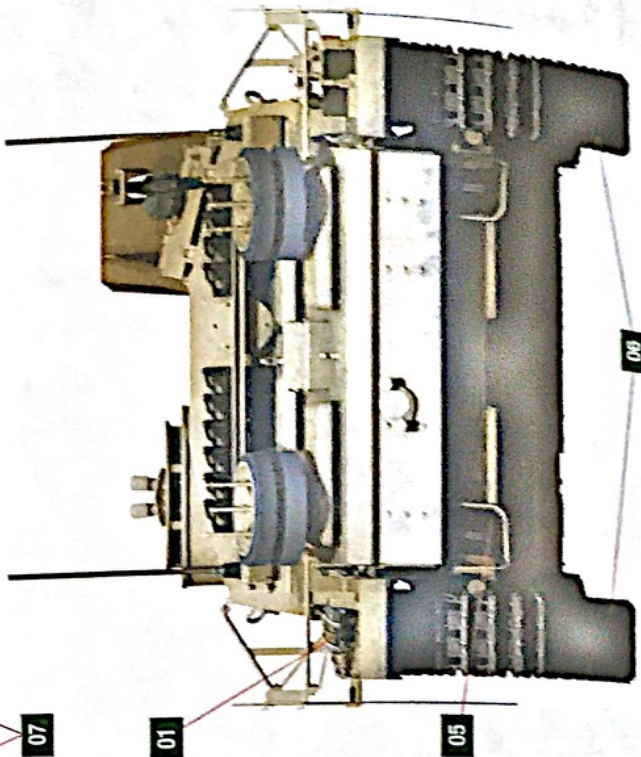
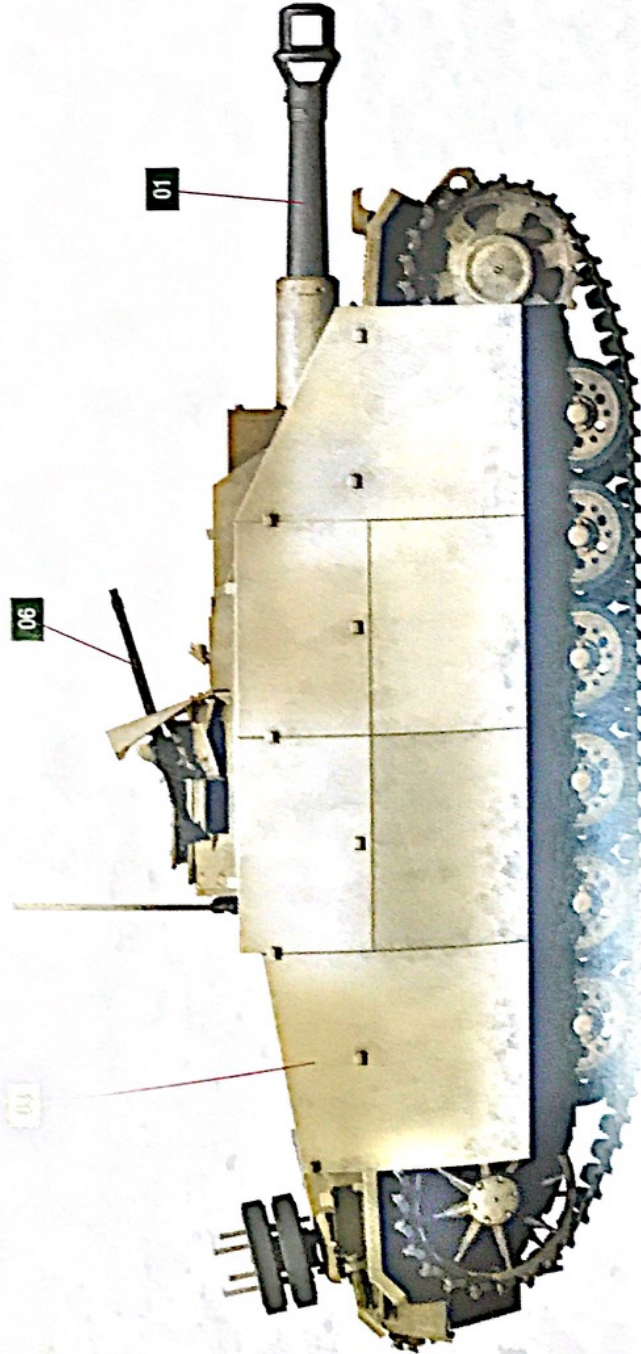
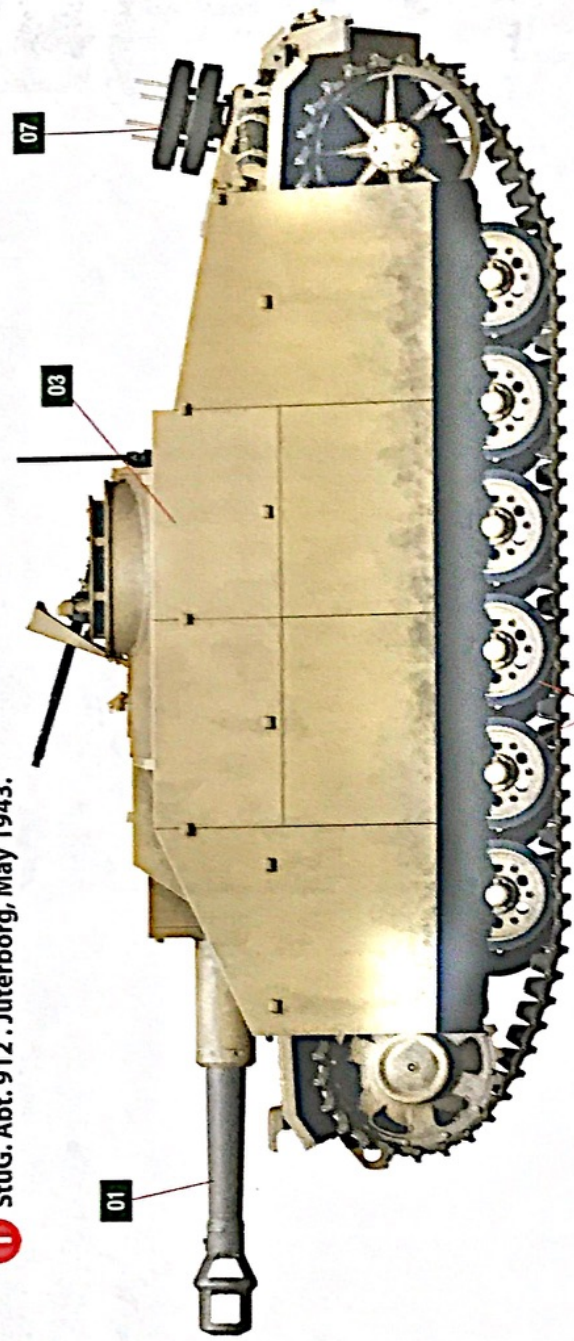
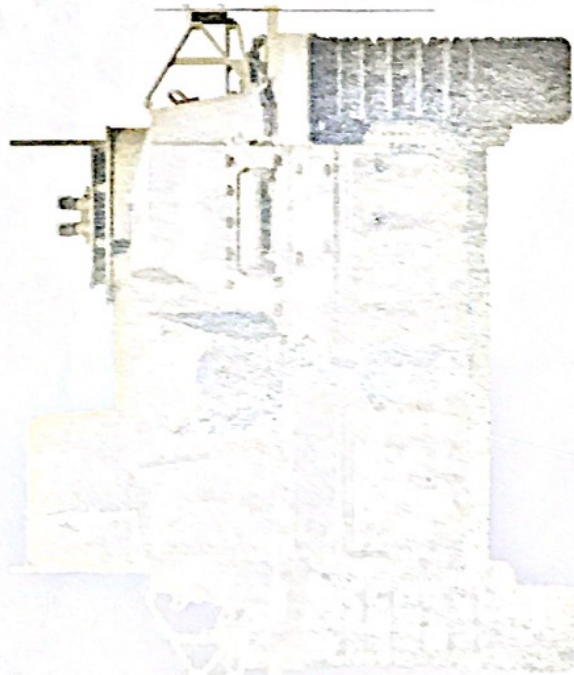

StuH 42 Ausf. G

Early Prod. May-June 1943

SCALE 1:35



PAINTING GUIDE

2 StuG Abt. 912. Eastern Front, Summer 1943.

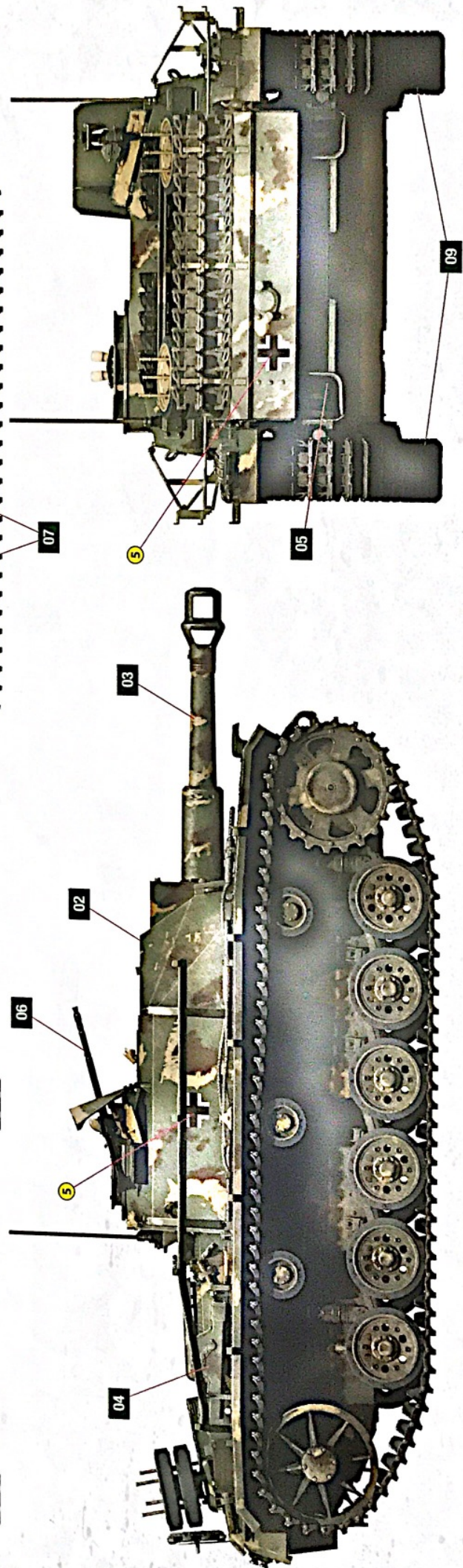
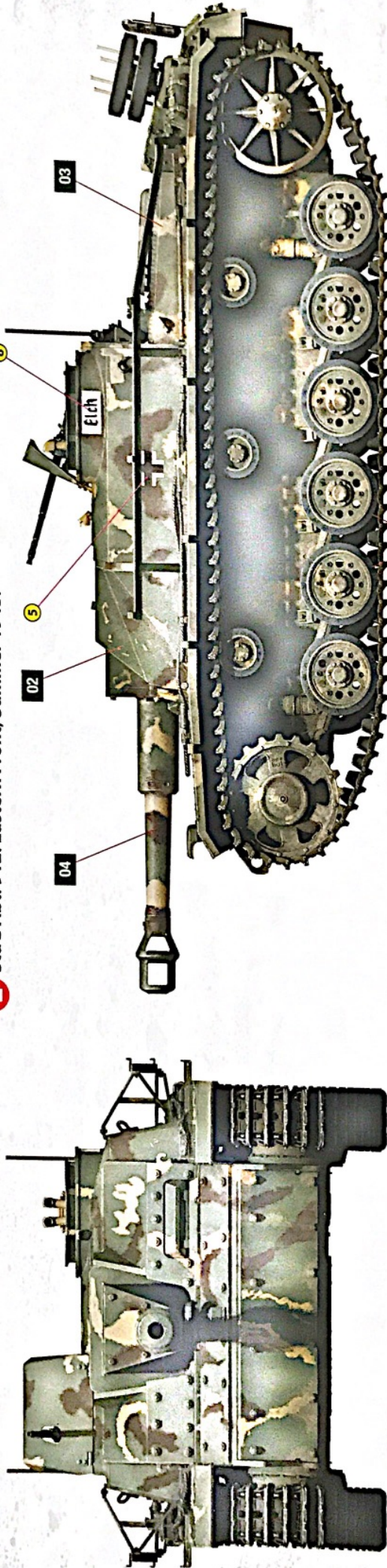

StuH 42 Ausf. G

Early Prod.

May-June 1943

SCALE
1:35

3 StuG Abt. 912. Eastern Front, Summer 1943 (with schürzen).

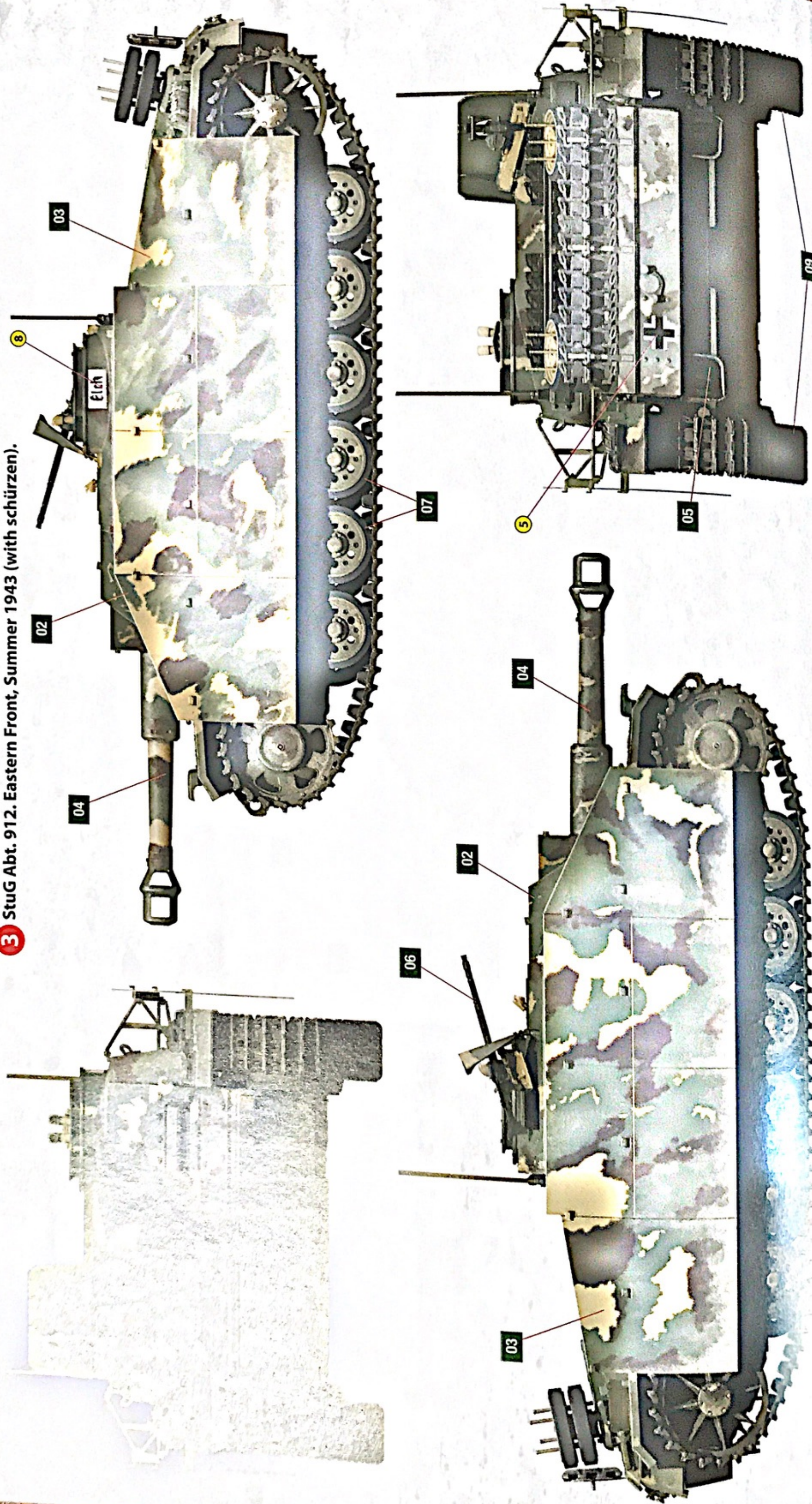

maquette le plastique en excès avec un cutter ou une lime.
 Voir la fin de cette colonne pour la signification des symboles.
 Après l'assemblage peut rester des pièces inutilisées.

Деталі відокремлювати від литників ножом або іншим ріжучим інструментом. Зачистити облой і місця зрізу за допомогою надфілю та наждачного паперу. Будівництво моделі виконувати згідно зі схемою. Для зручності побудови кожна деталь позначена номером.
 Після складання можуть залишитися невикористані деталі.

Детали отделить от литников ножом или другим режущим инструментом. Зачистить облой и места среза при помощи надфиля и наждачной бумаги. Сборку моделей производить согласно схеме сборки.
 Для удобства сборки каждая деталь обозначена номером. После сборки набора могут остаться неиспользованные детали.

ZUR BEACHTUNG
 Kleber und Farbe nicht nahe von offenem Feuer verwenden und das Fenster von Zeit zu Zeit zur Belüftung öffnen.
 Zum Abschneiden der Teile vom Verbundstück eine Modellierschere verwenden und die überstehenden Plastikteile mit einem Messer oder einer Feile beseitigen.
 Die Bedeutung der Symbole finden Sie unten in dieser Spalte.
 Nach dem Zusammenbau des Modells, können einzelne Teile übrig bleiben

ATTENZIONE
 Non usare colla o vernice vicino a fiamme esposte, e aprire le finestre di tanto in tanto per cambiare l'aria. Quando si staccano parti del carrello, usare forbici da modellismo e eliminare la plastica in eccesso con un coltello o una lima. Vedere in fondo a questa colonna per il signifi.
 Dopo l'assemblaggio possono rimanere parti inutilizzate.

CAUTION
 When you use glue or paint, do not use near open flame, and use in well ventilated room. When you take parts off from the runner frame, use modeling scissors or cutter.
 See the bottom of this column for the meaning of symbols.
 Extra details can remain after assembling of the kit.

PARTS

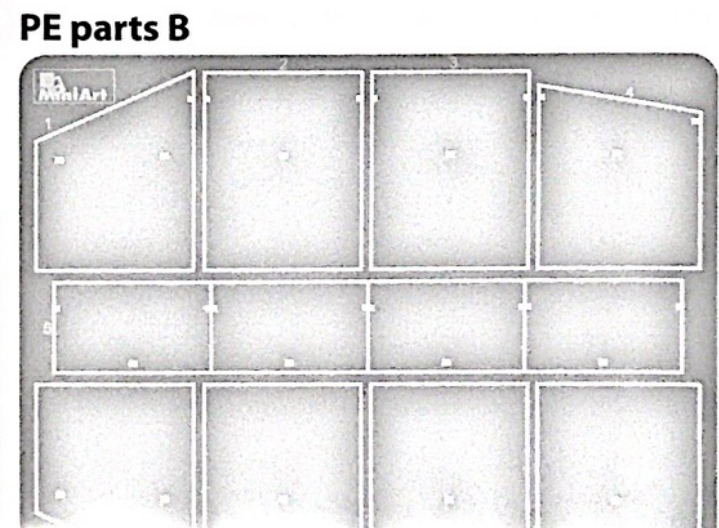
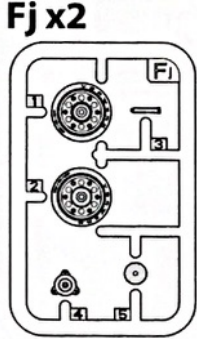
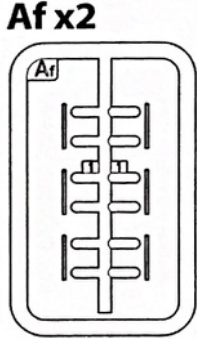
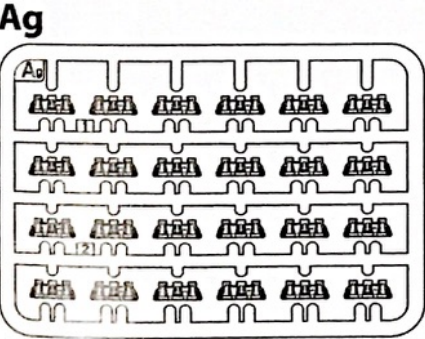
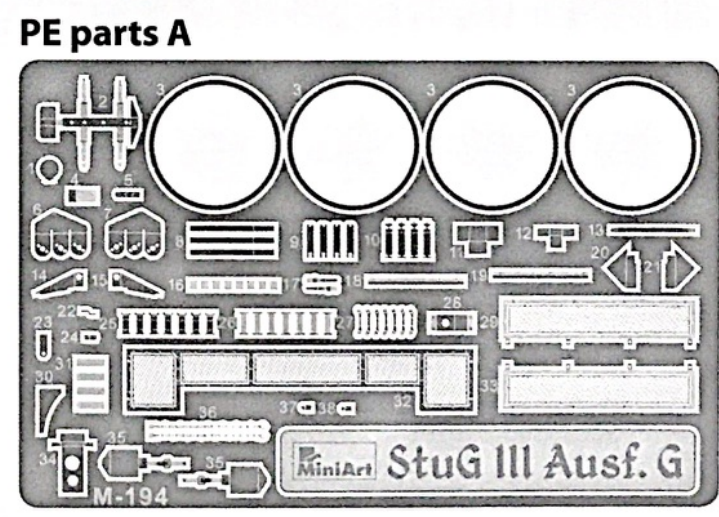
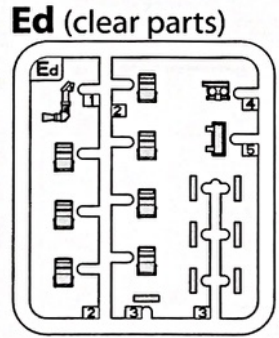
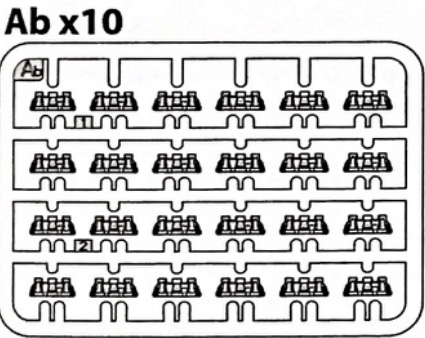
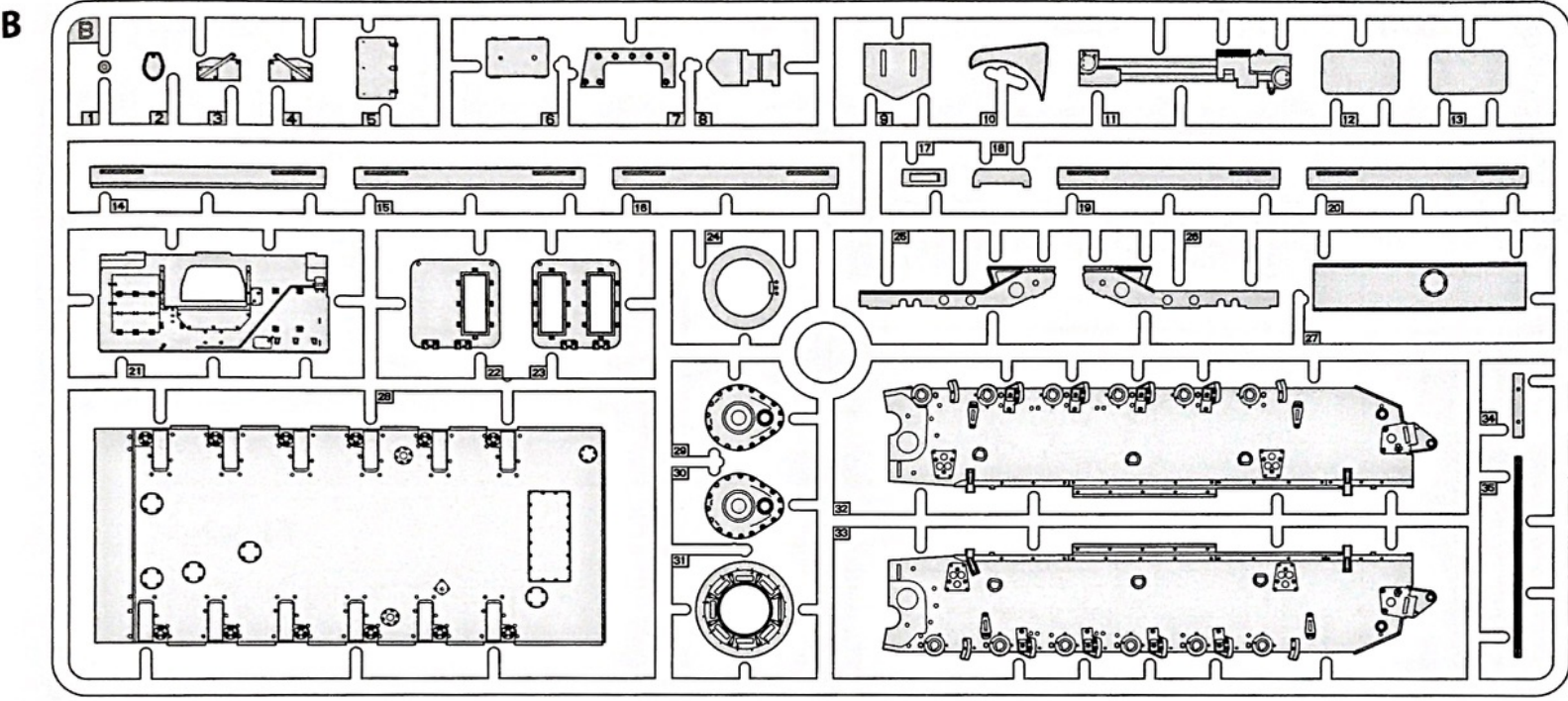

Decal Sheet

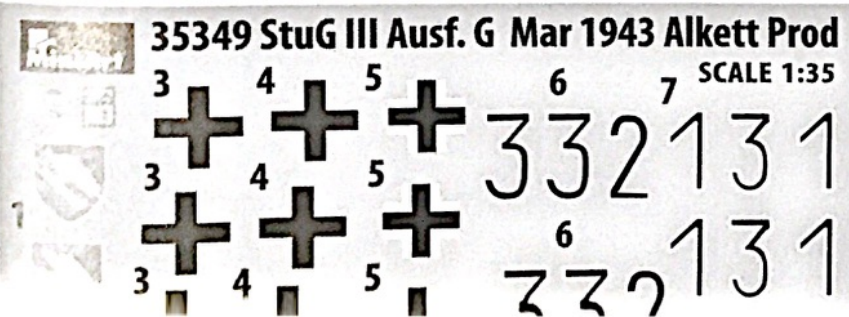



MAKE 2PCS
 2 TEILE FERTIGEN
 EFFECTUER 2 PIECES
 FARE DUE PEZZI
 TEE 2 KPL
 GOR 2 ST
 ПОВТОРИТЬ ДВА РАЗА
 КІЛЬКІСТЬ РАЗІВ

DO NOT CEMENT
 NICHT KLEBEN
 NE PAS COLLER
 NON INCOLLARE
 EIILIMAA
 LIMMAEJ
 НЕ ИСПОЛЬЗОВАТЬ КЛЕЙ
 НЕ КЛЕІТИ

OPTIONAL
 NACH BELIEBEN
 FACULTATIF
 FACOLTATIVO
 VALINNANVARAINEN
 VALBAR
 ВАРИАНТЫ

OPEN HOLE
 OFFNEN
 FAIRE UN TROU
 FORO APERTO
 AVAA REIKÄ
 ÖPPNÄ Hålet
 СДЕЛАТЬ ОТВЕРСТИЕ
 ЗРОБИТИ ОТВІР

REMOVE
 ENTFERNEN
 RETIRER
 SEPARARE
 POISTA
 AVLÄGSNA
 ОТРЕЗАТЬ
 ВІДРІЗАТИ

ANNEAL THE PART
 GLODGNINGSDEL
 PARTIE DE RECUT
 PARTE RECOCIDA
 PARTE RECOCIDA
 HENKUTTAA OSA
 ОТЖЕЧЬ ДЕТАЛЬ
 ВІДПЛАТИТИ ДЕТАЛЬ

BEND
 BIEGEN
 PLIER S'IL VOUS PLAİT
 PIEGARE
 TAITA
 ВОСКА
 ВЫГНУТЬ
 ВИГНУТИ

SCRATCHBUILD
 AM MEISTEN ZU MAC
 FAIRE LE PLUS
 RENDITI
 TEE ITSE
 GOR DIG SJÄLV
 СДЕЛАТЬ САМОМУ
 ЗРОБИТИ САМОМУ

PARTS

Fk x2

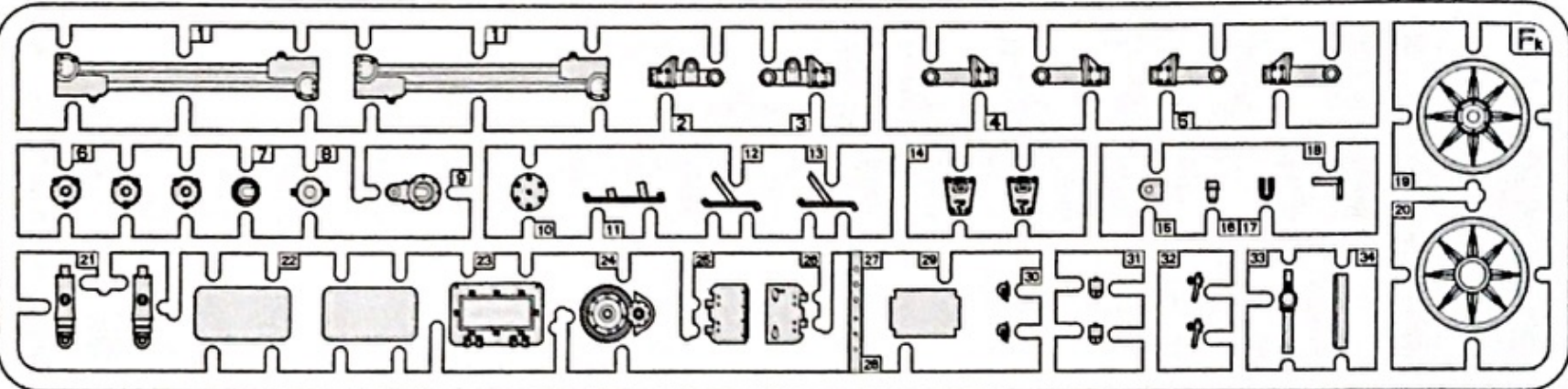

Fd x4

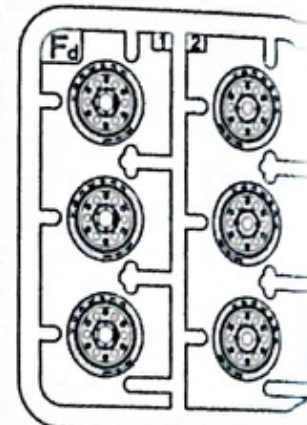

He

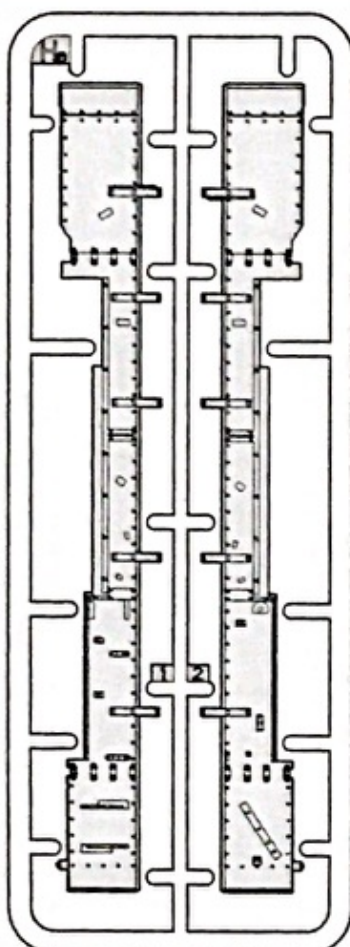

Gf

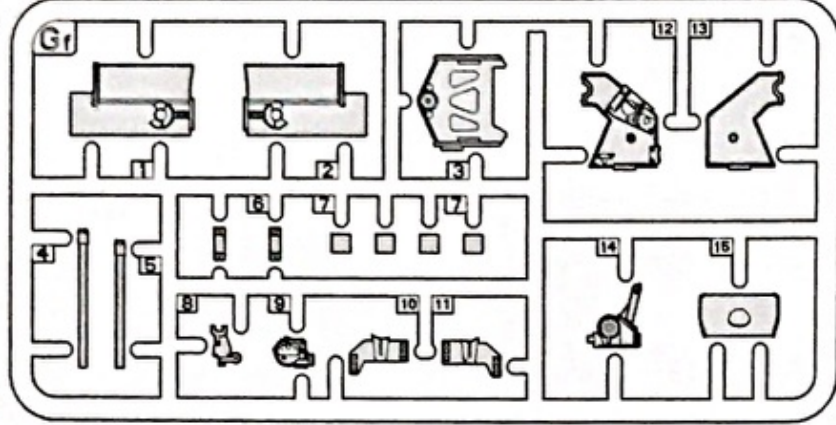

Ha

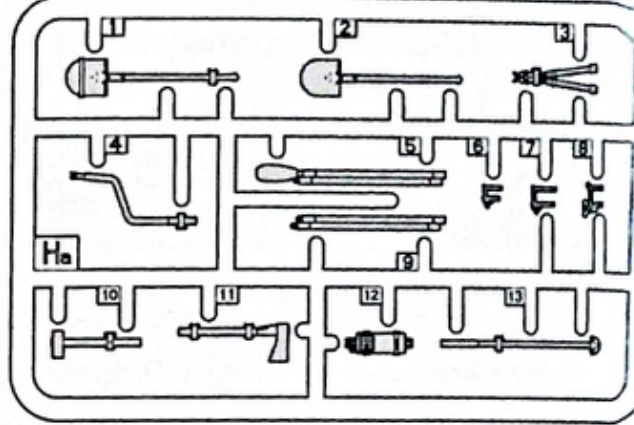

Mc

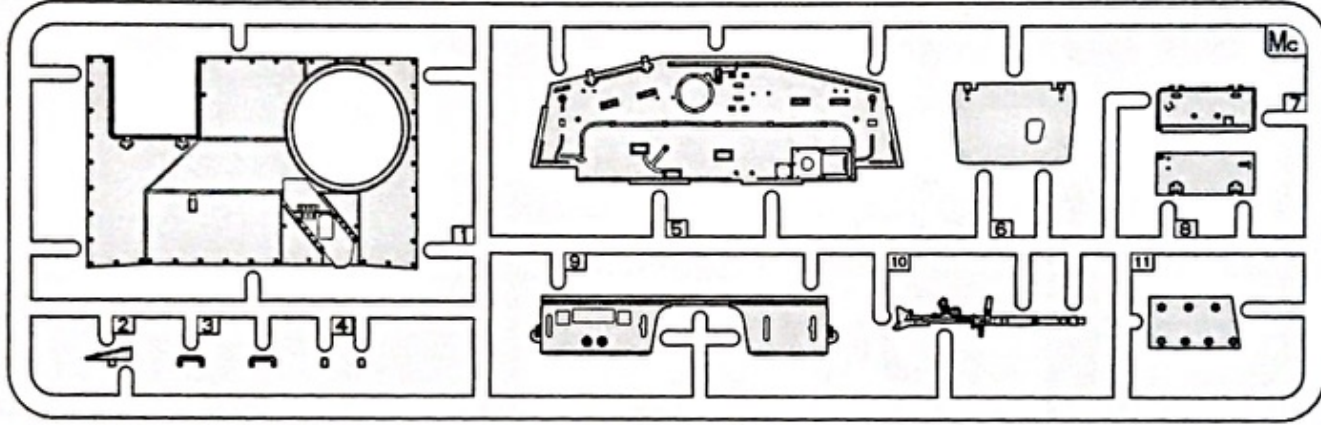

Fh x2

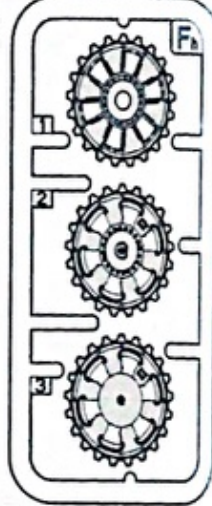

Jb

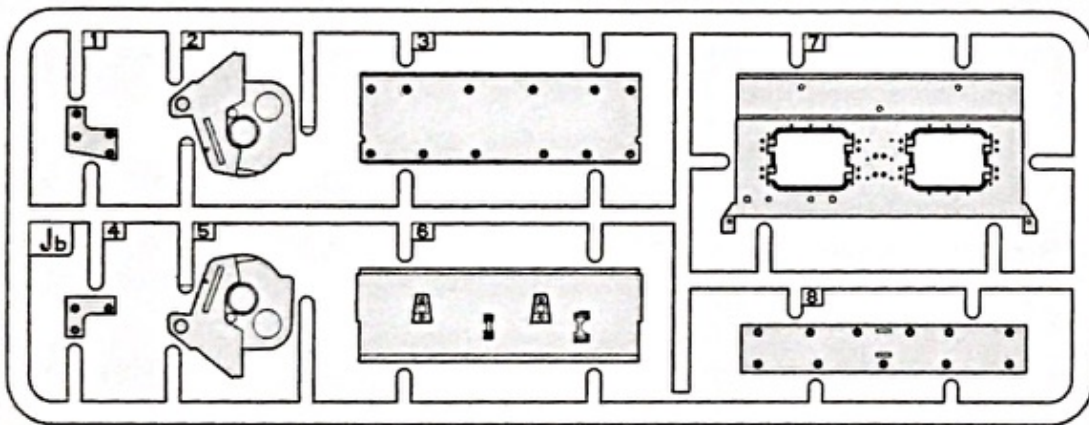

Je

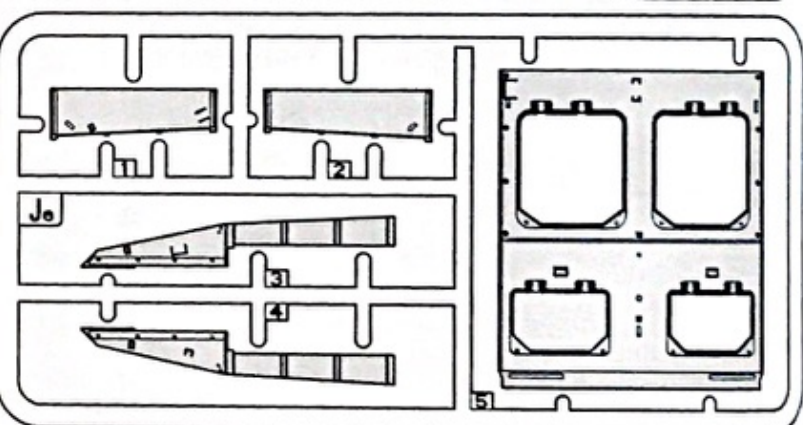

Kc

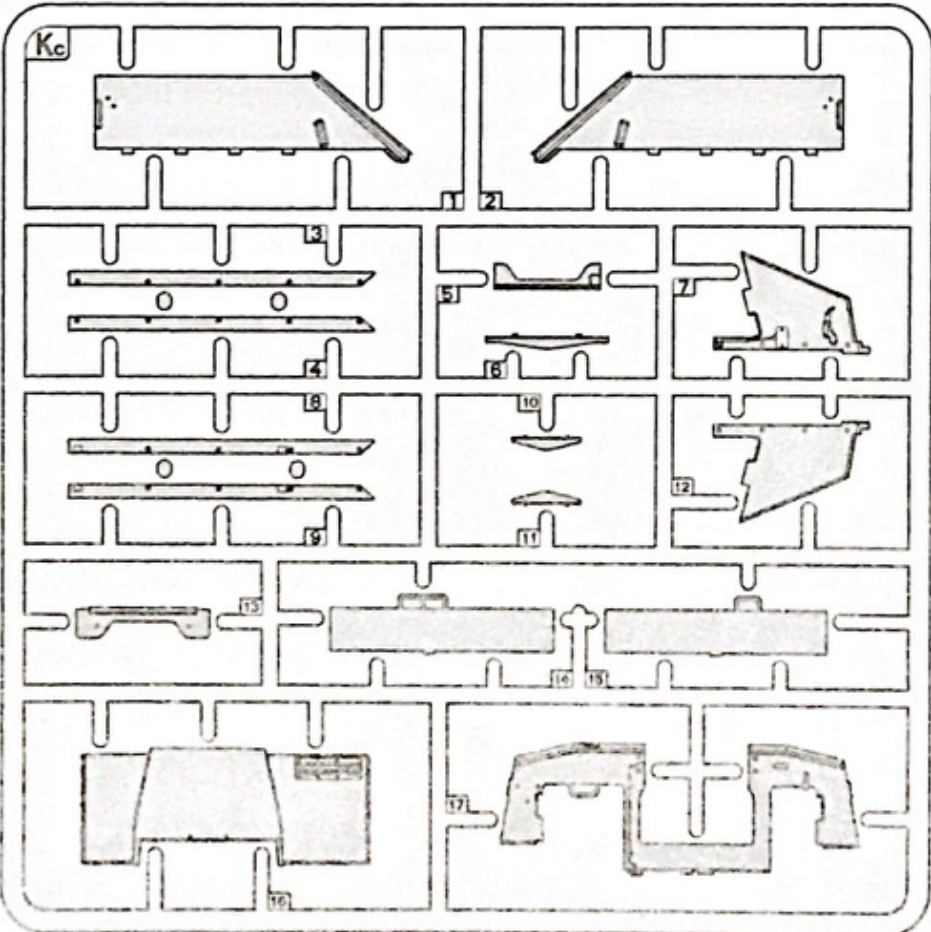

Hc

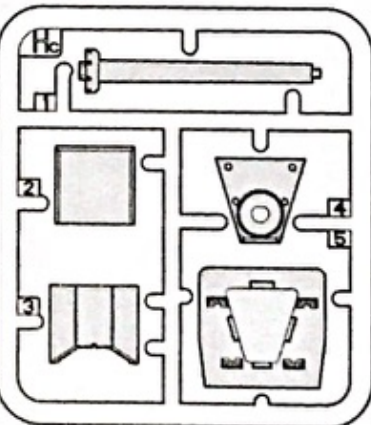

Md

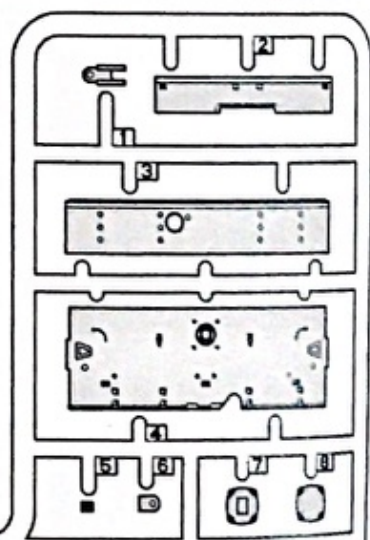

Fb x3

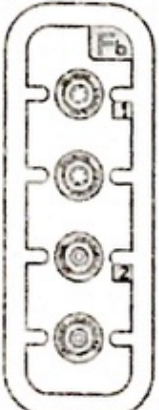

F x2

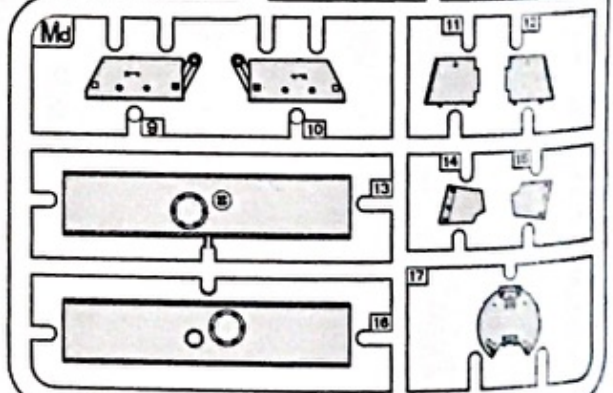
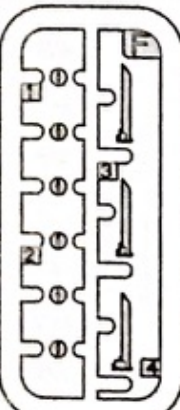

Cd

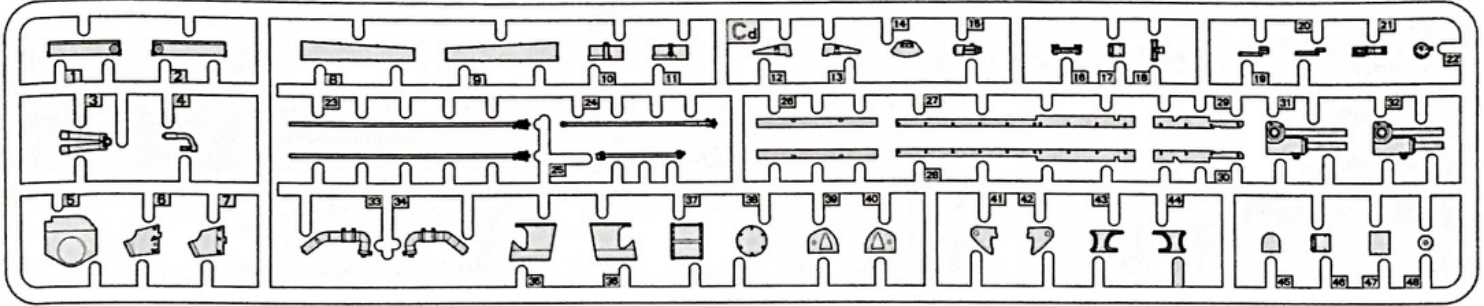

Jd

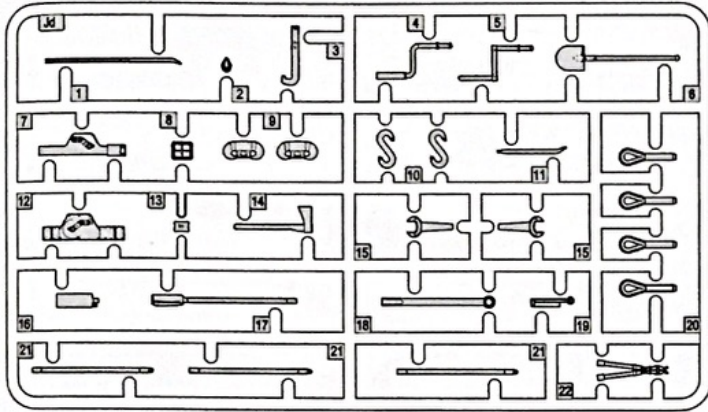

Hb

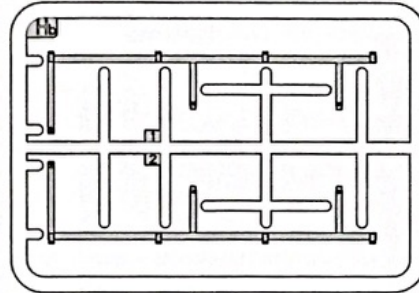

Gb

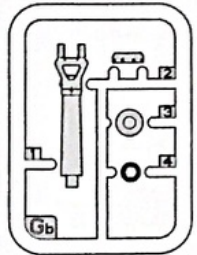

ASSEMBLY GUIDE

1

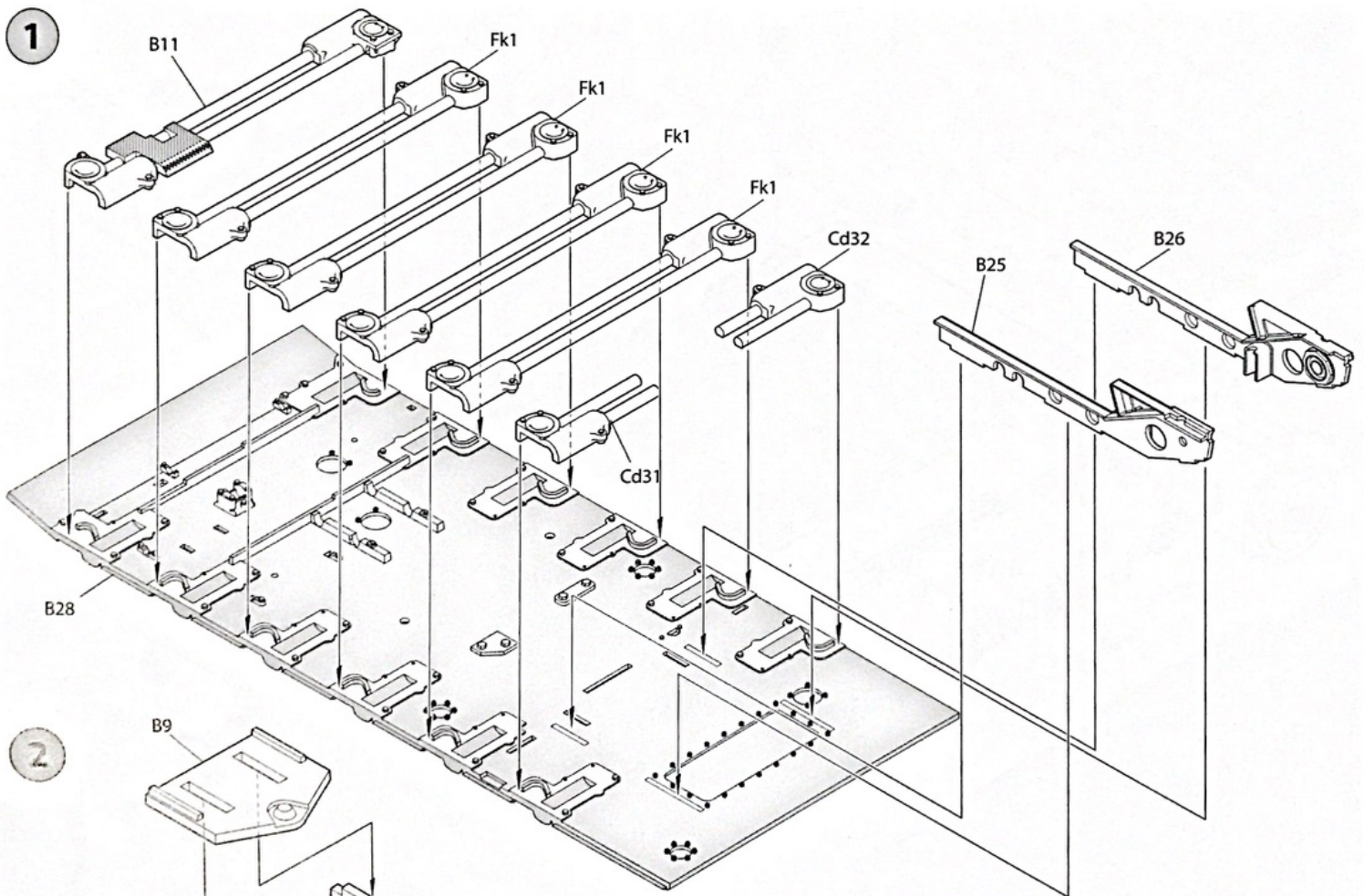

2

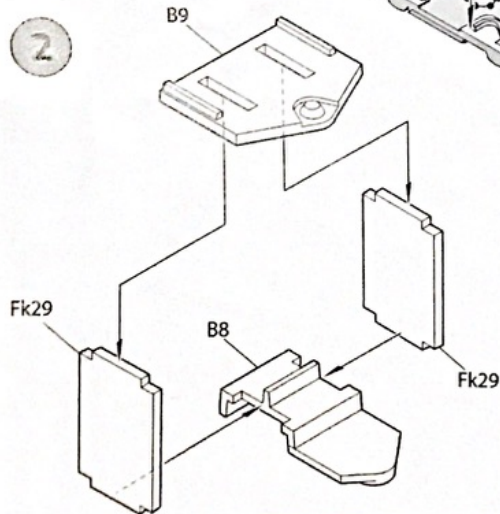

3

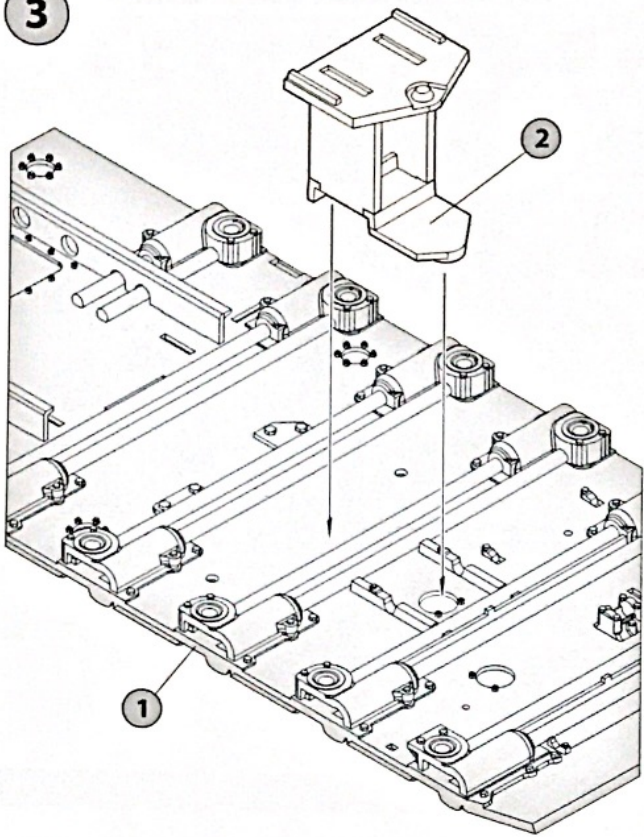

4

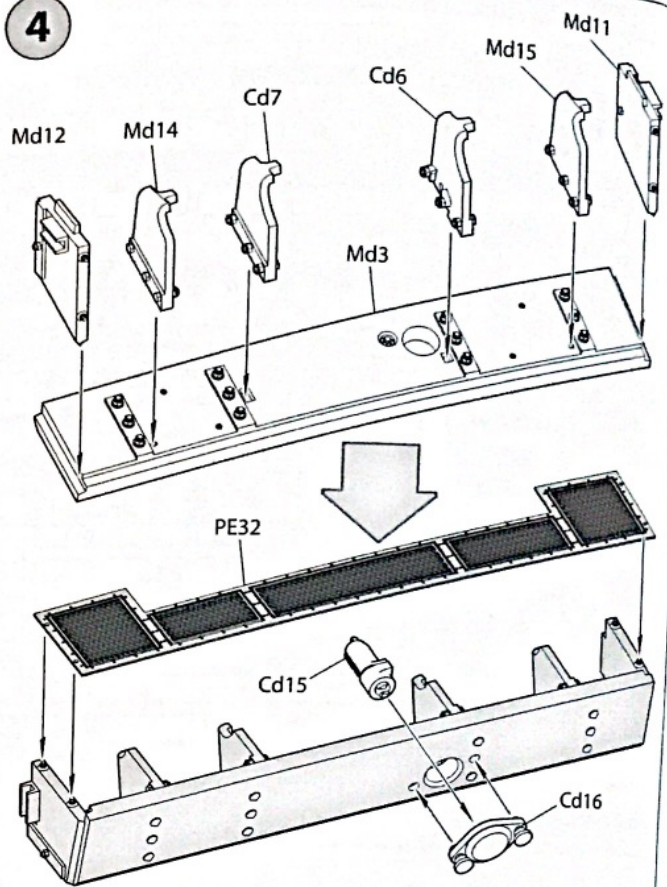

5

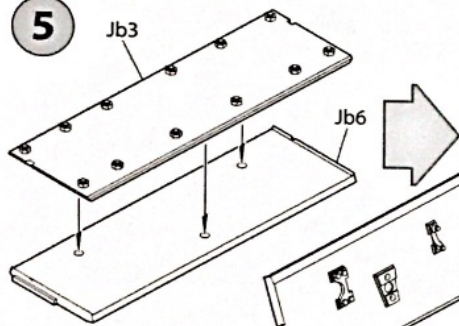

3

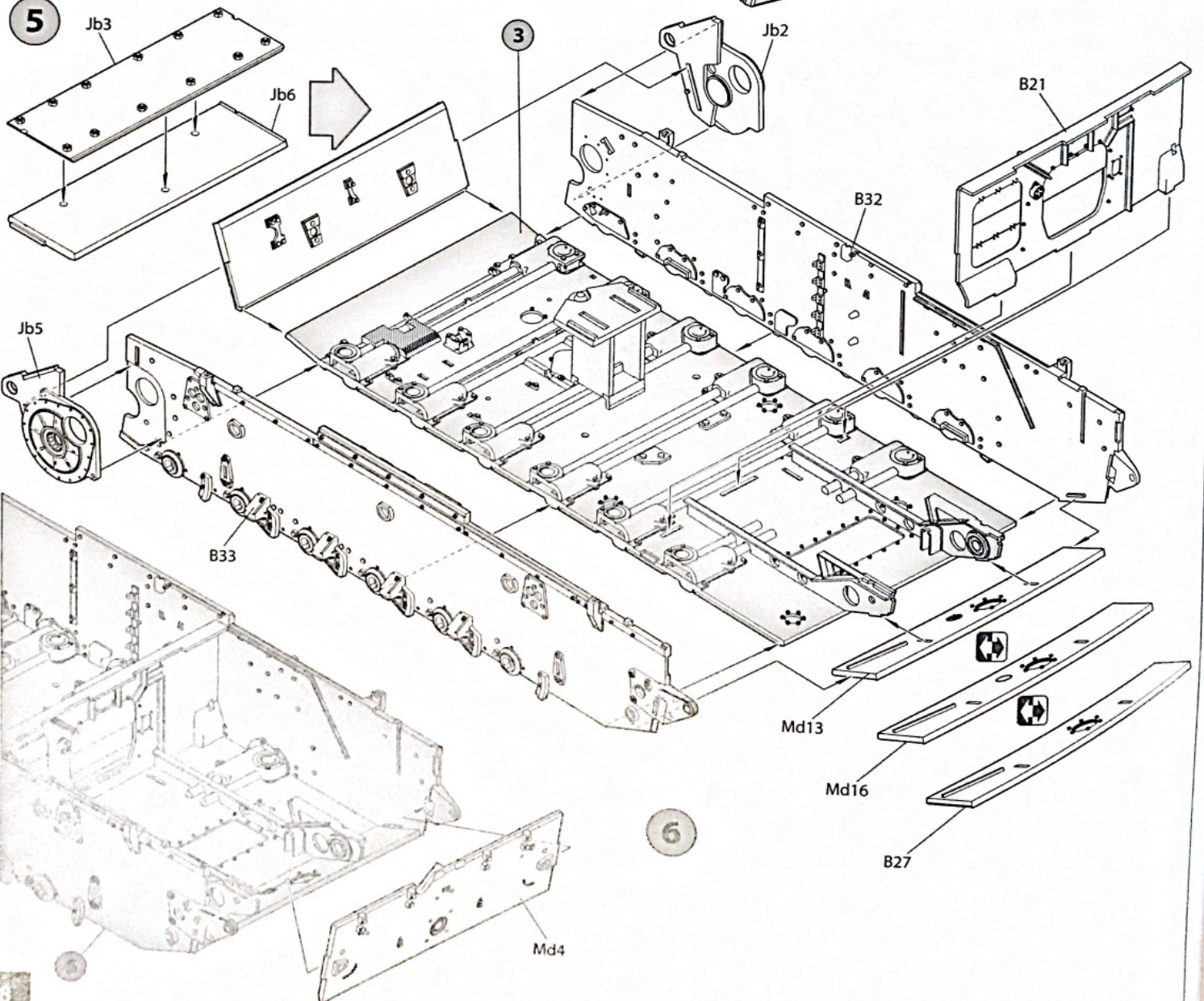

6

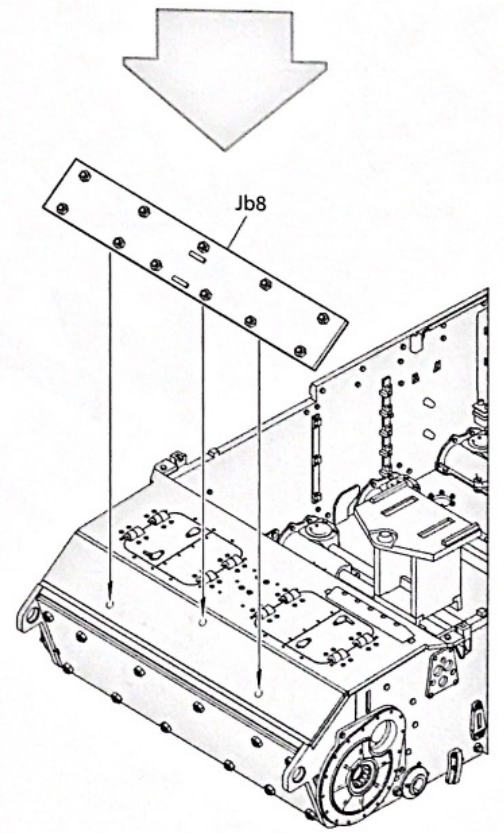
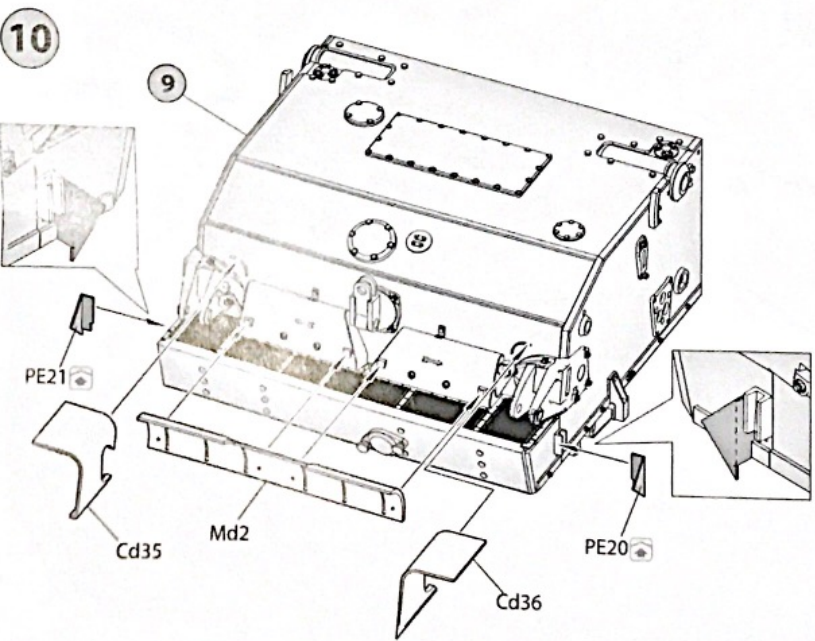
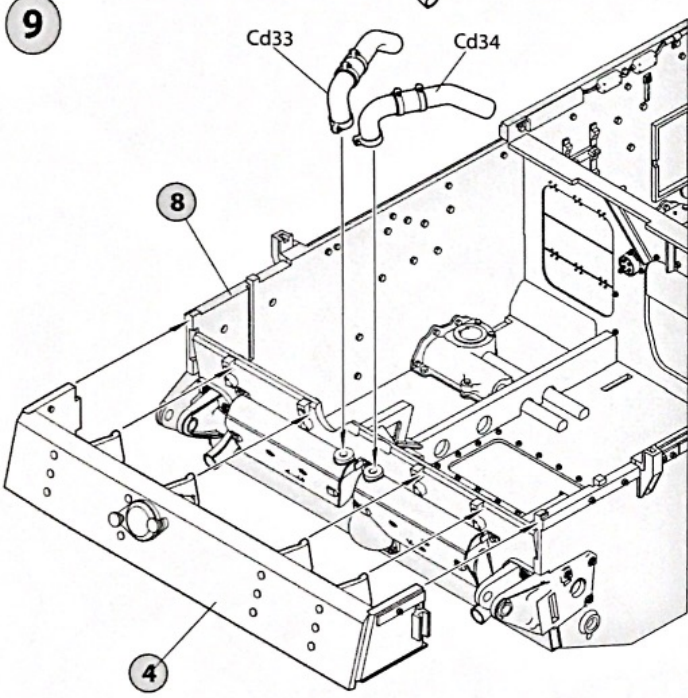
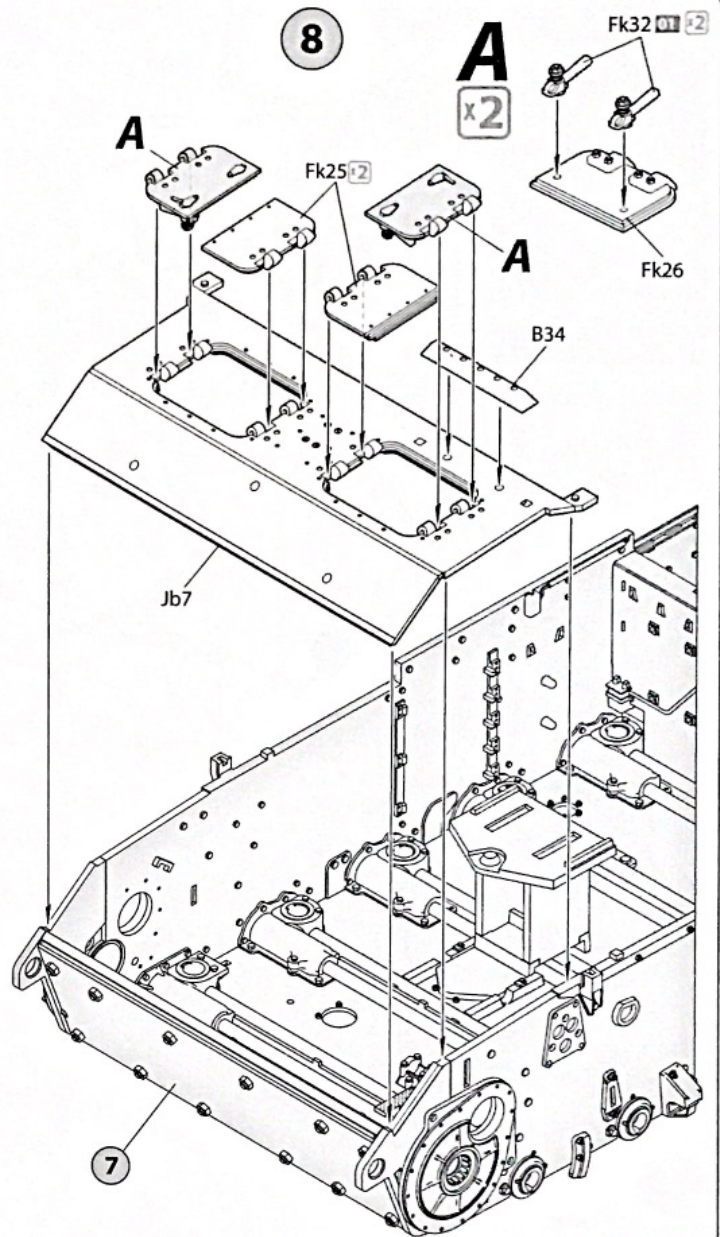
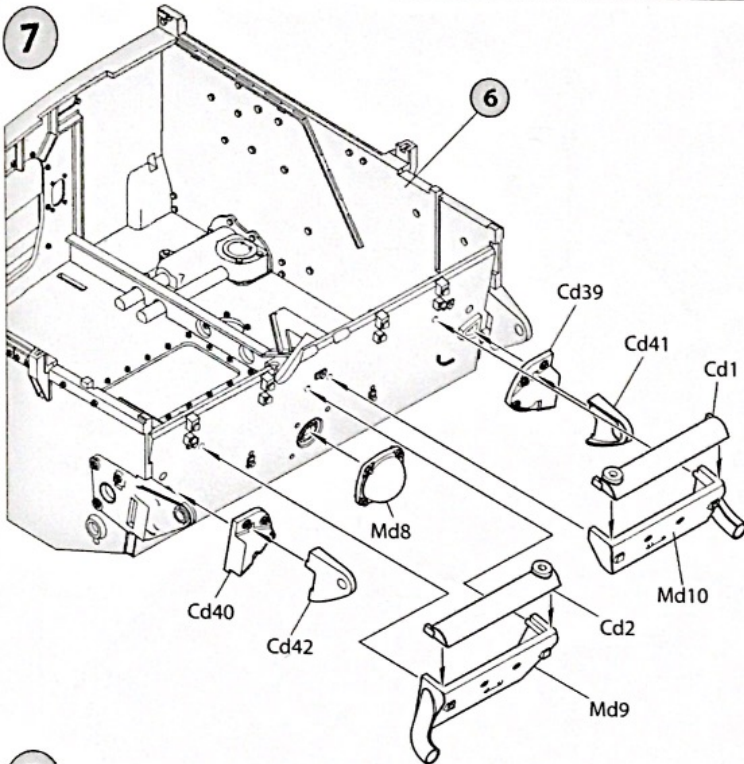

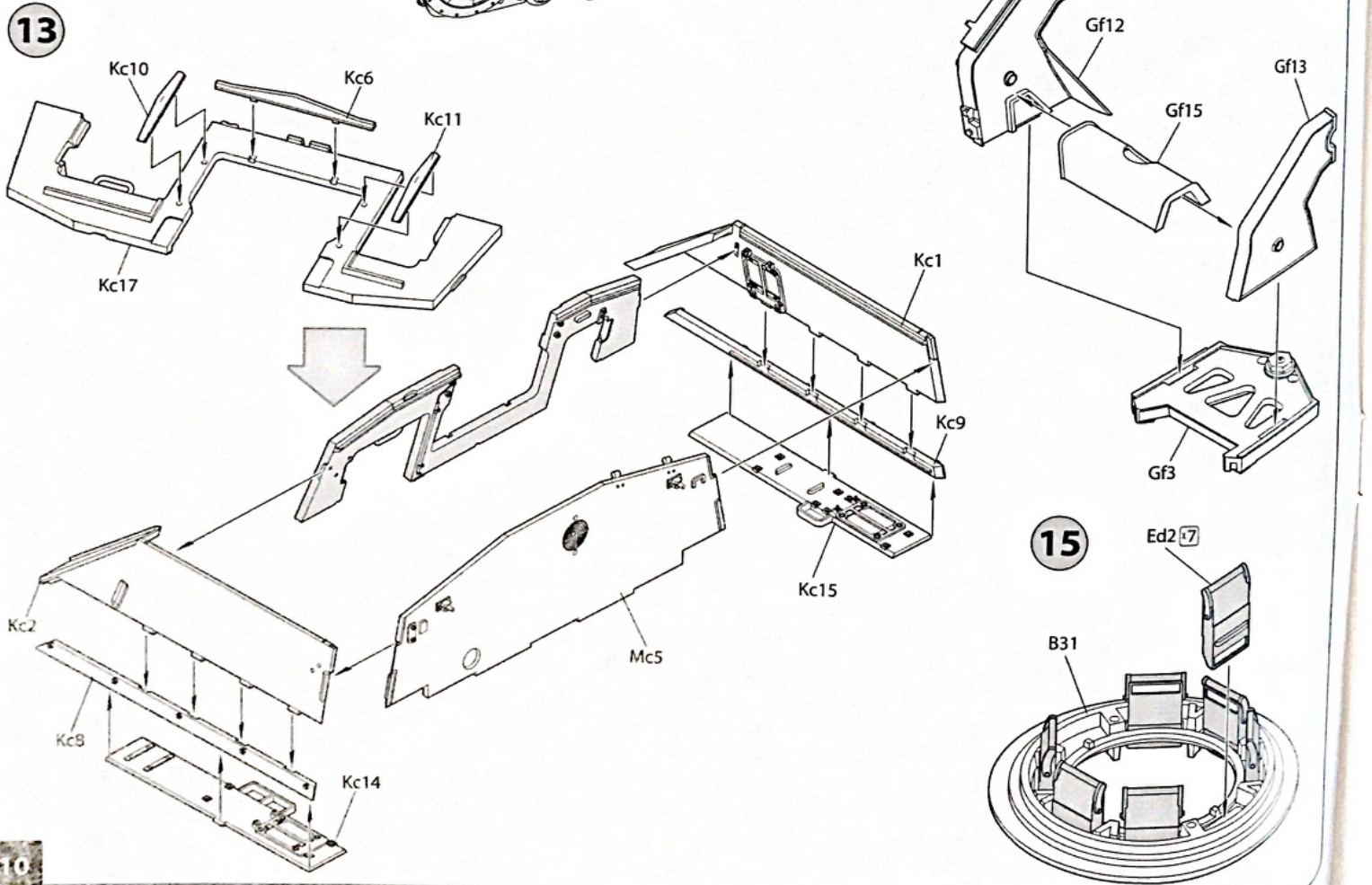
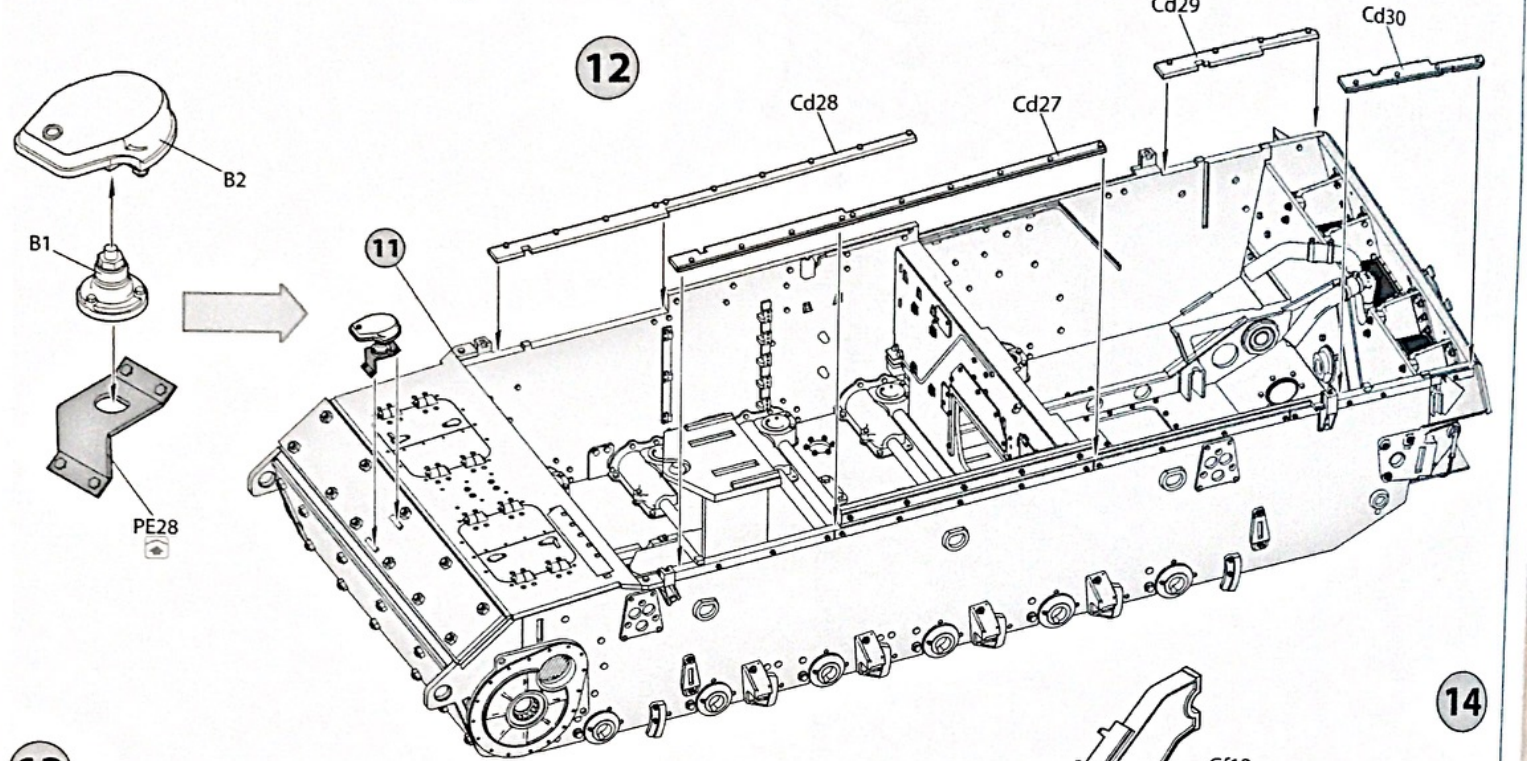
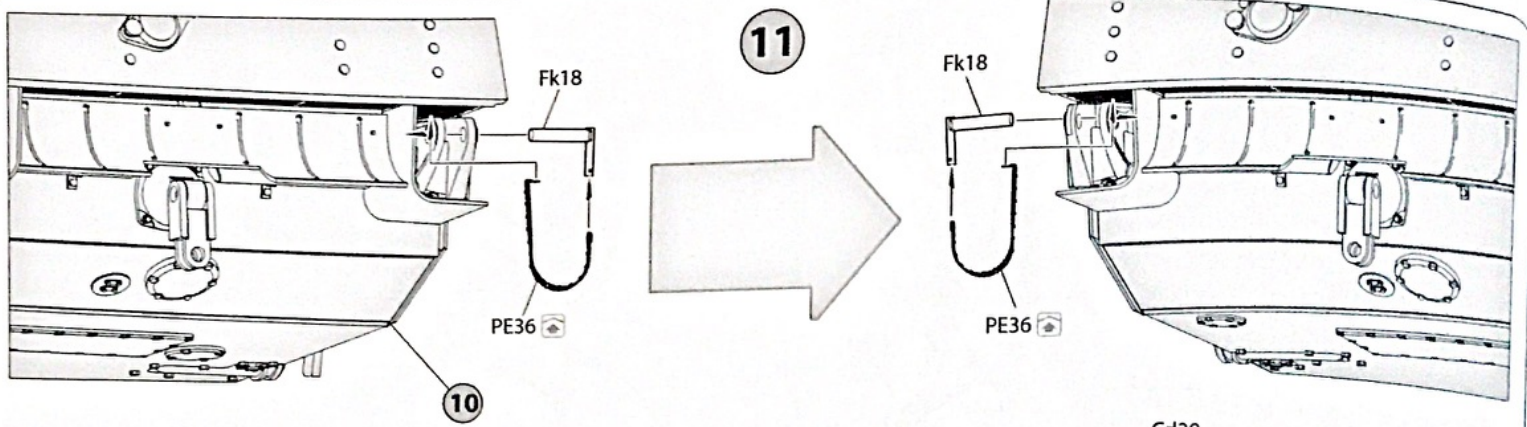

16

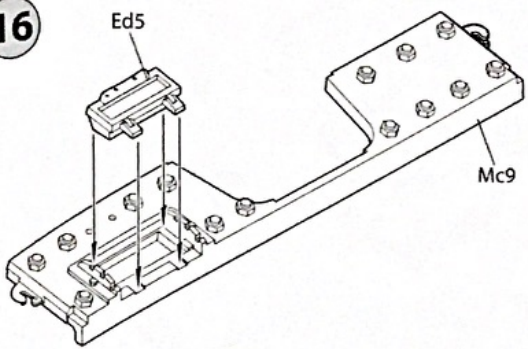

17

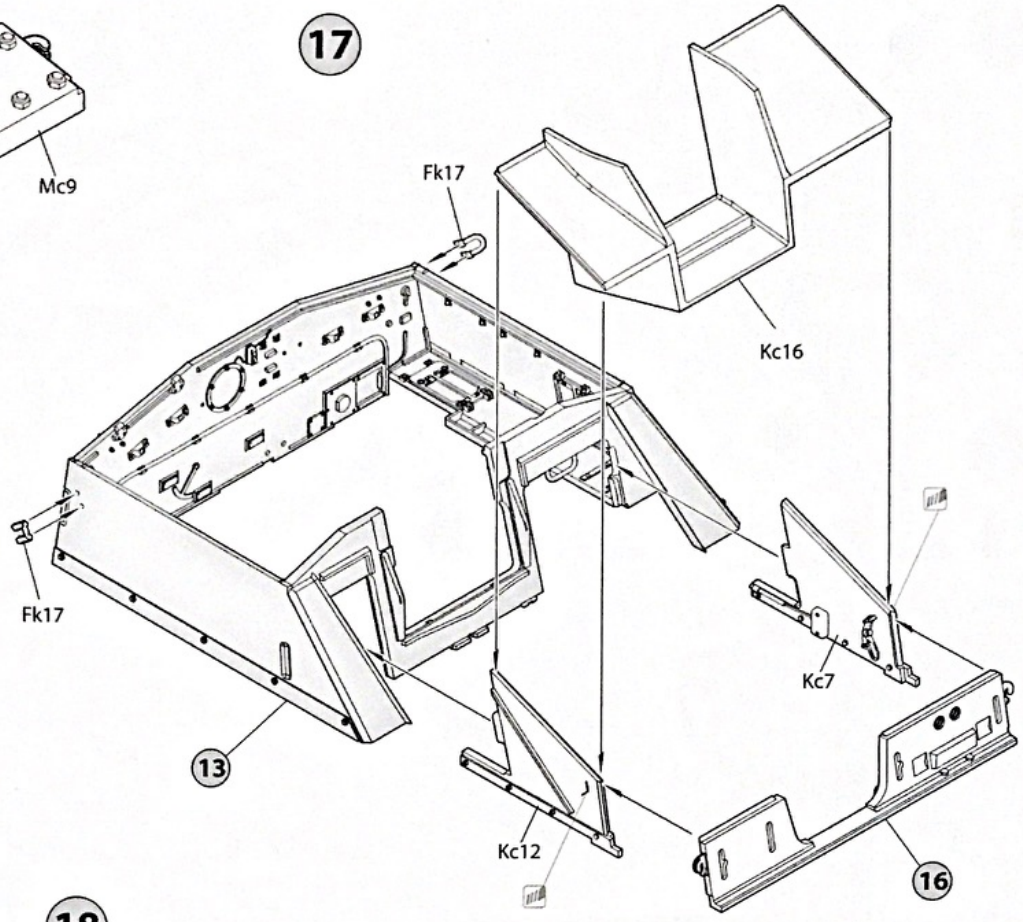

18

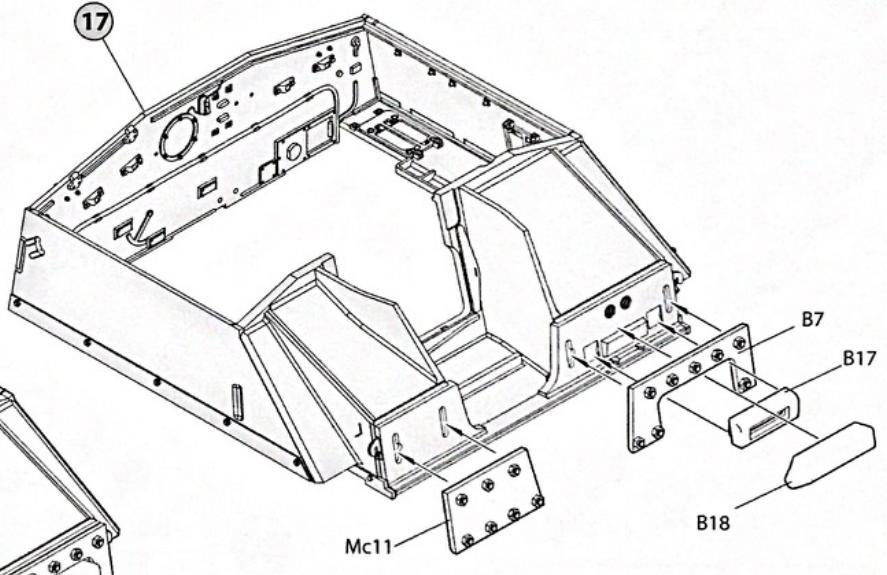

19

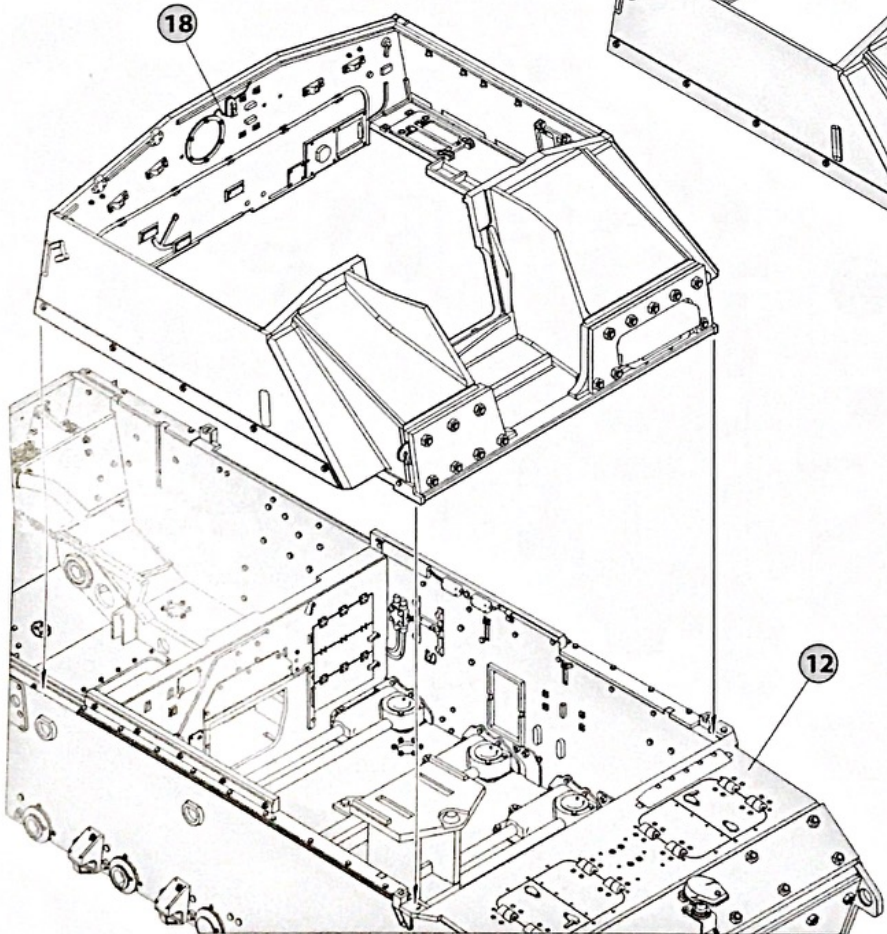

20

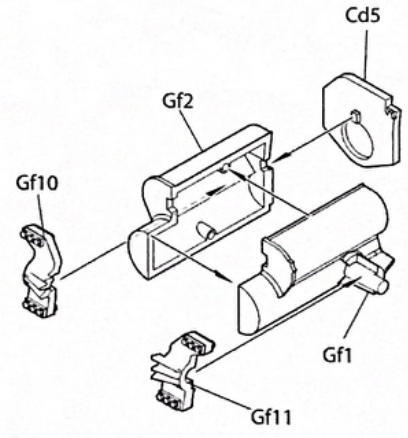

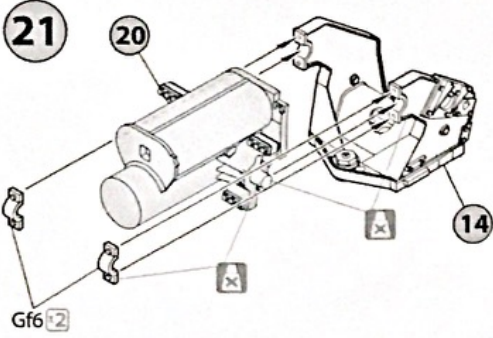

23

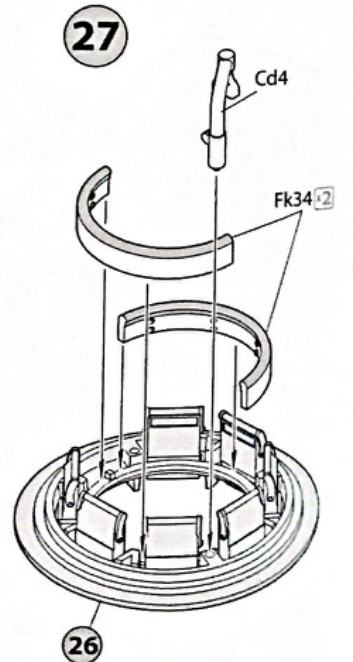
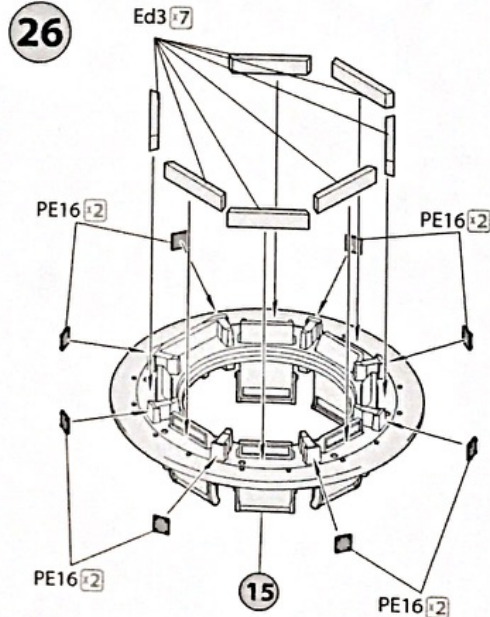
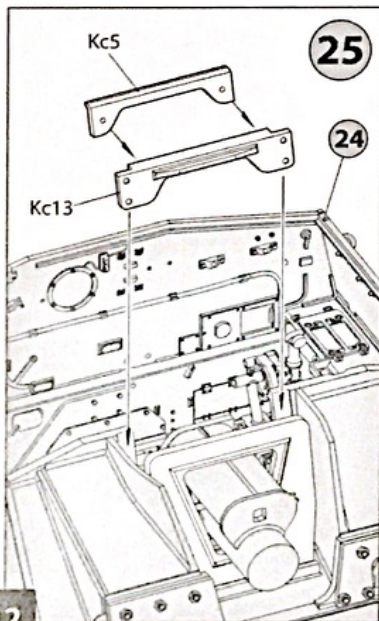
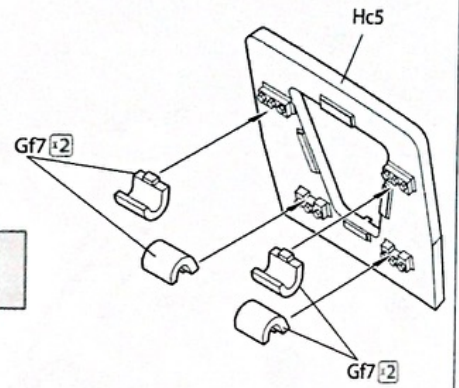
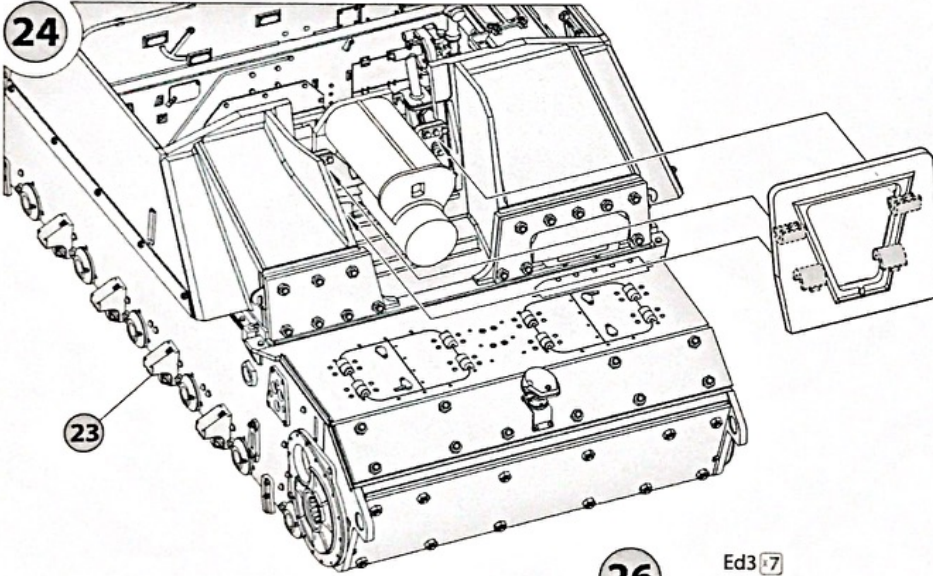
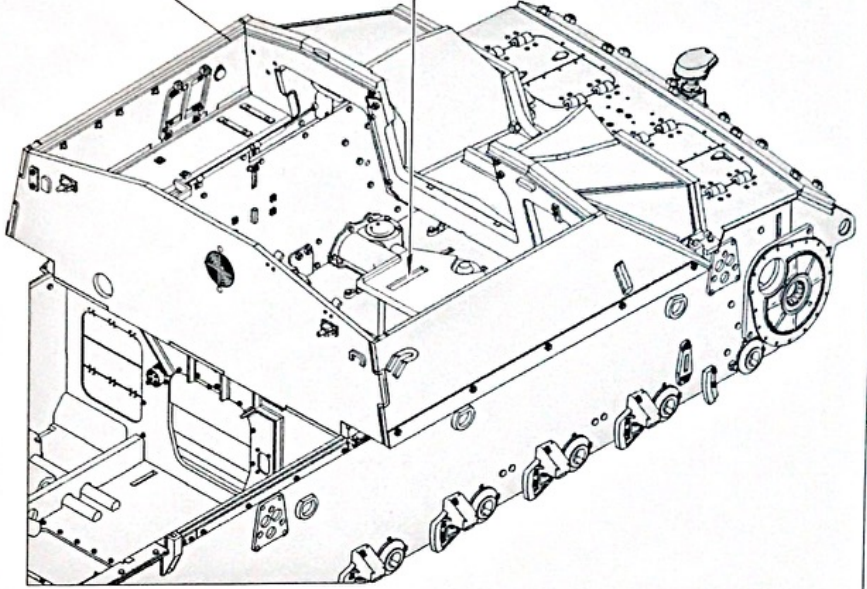
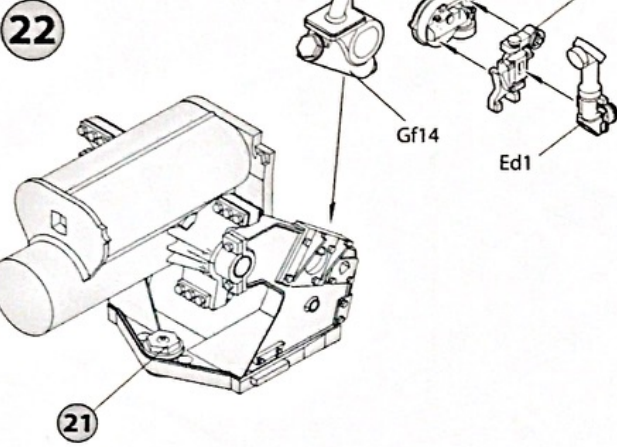
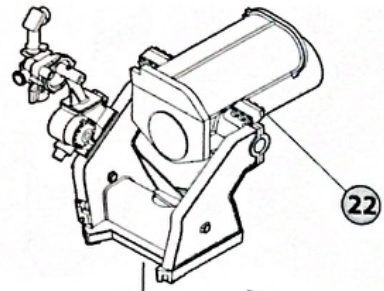

Parts PE16 for advanced modeller

28

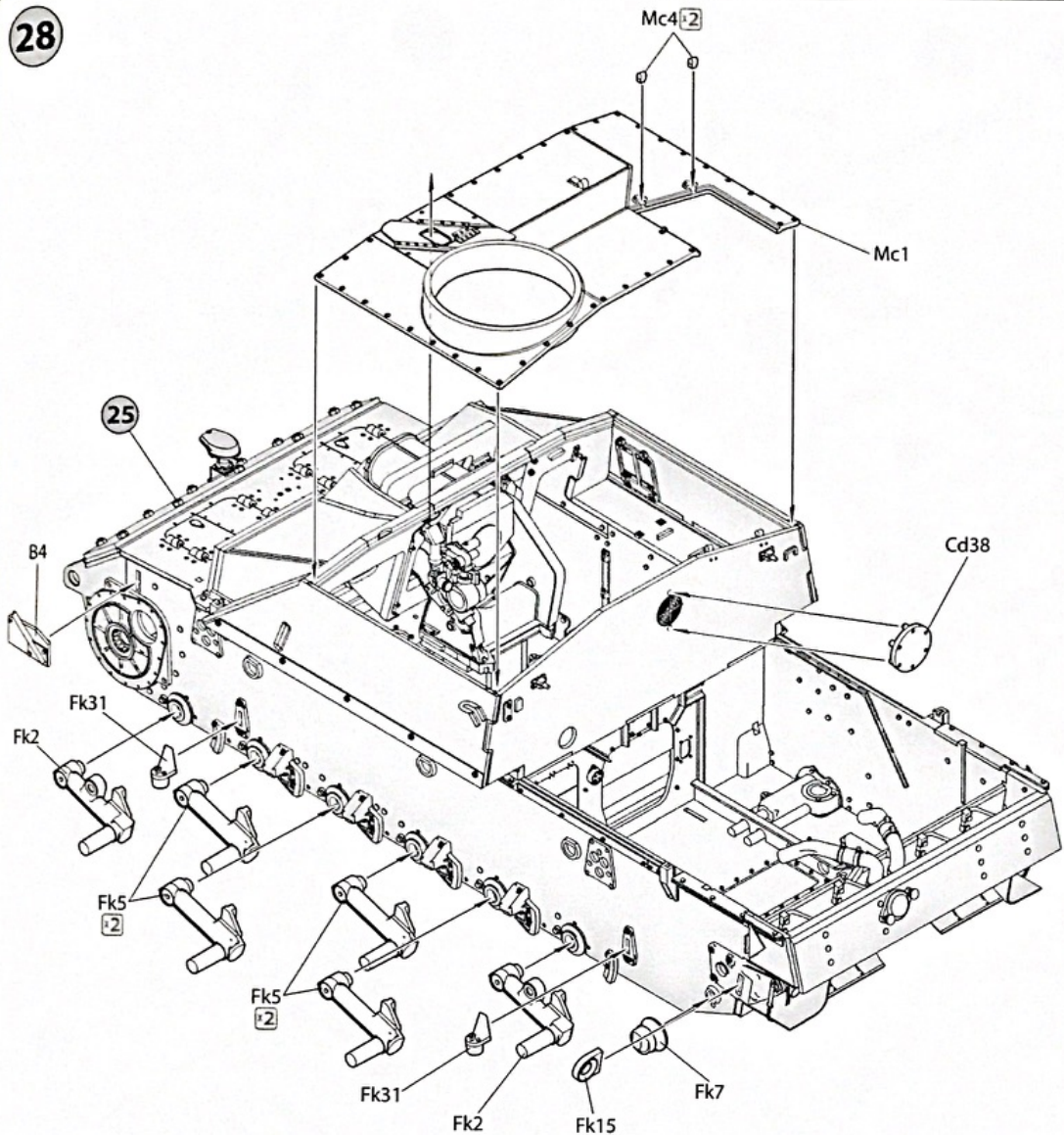

29

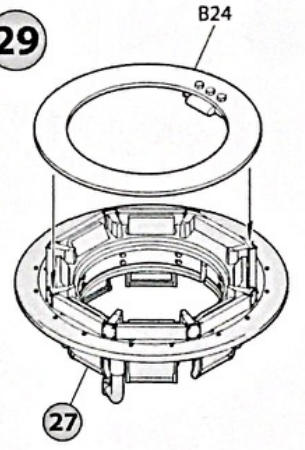

30

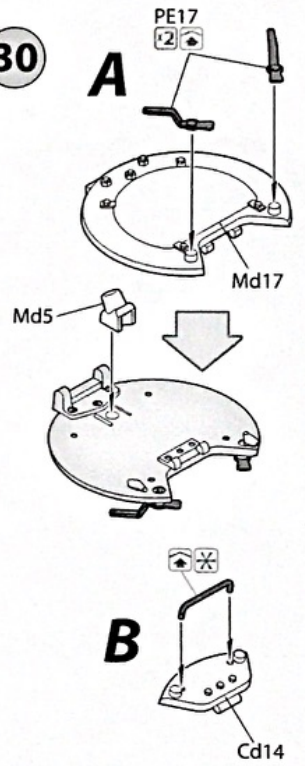

31

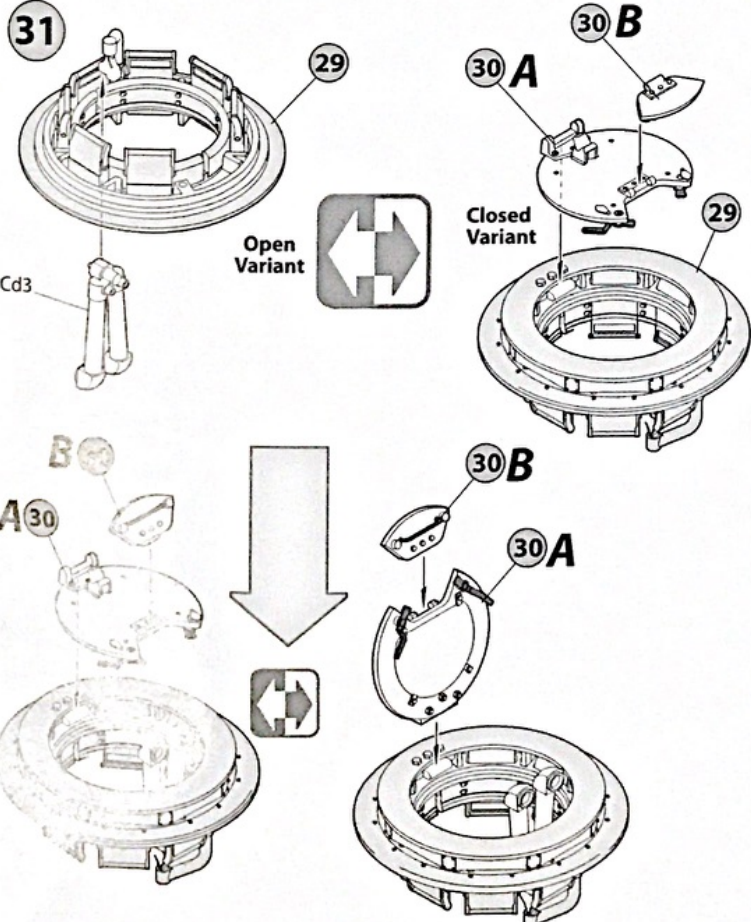

32

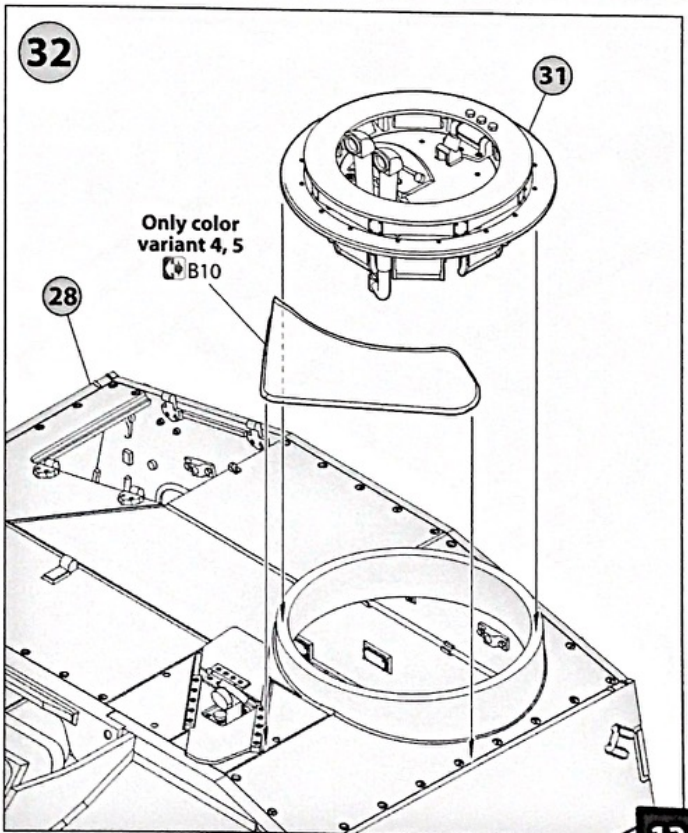

33

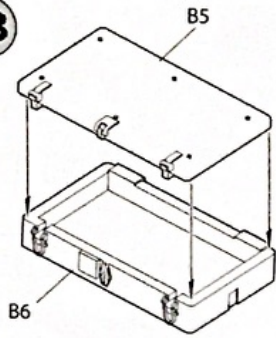

34

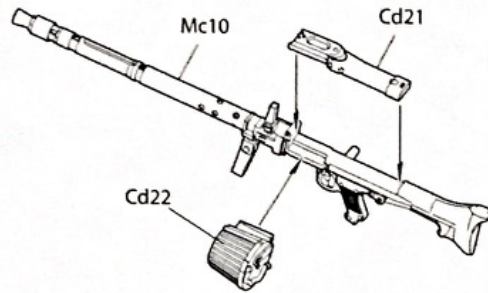

35

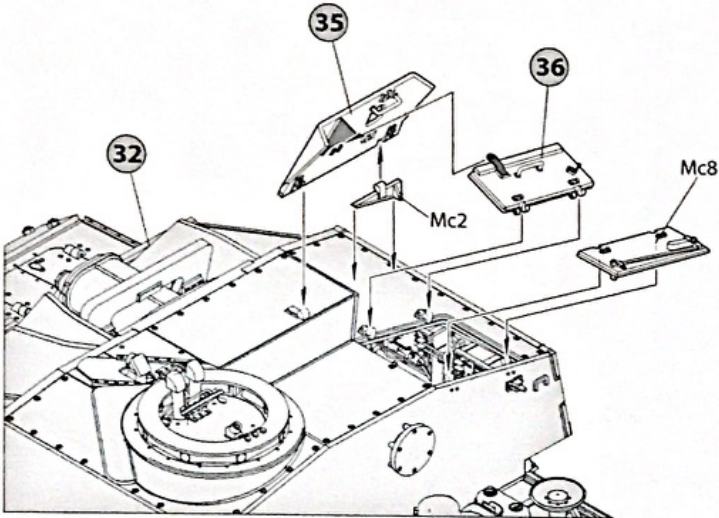
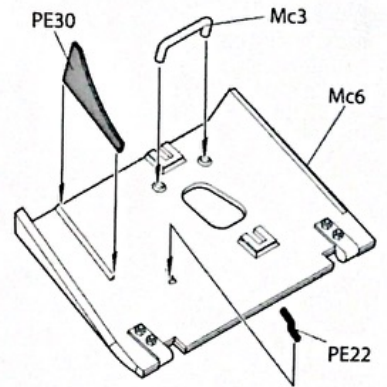

37



36

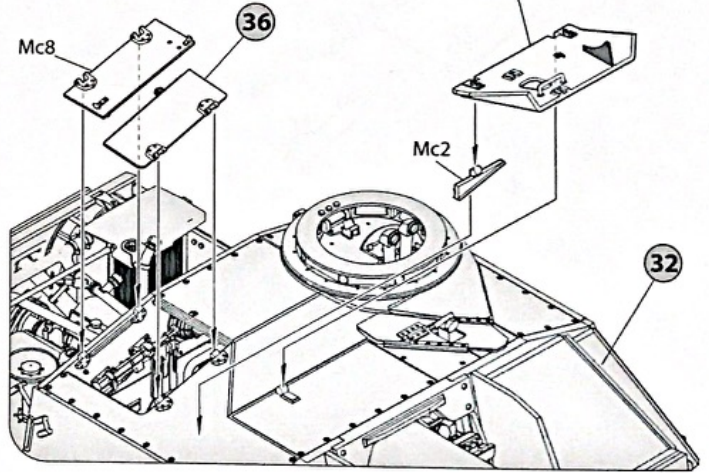
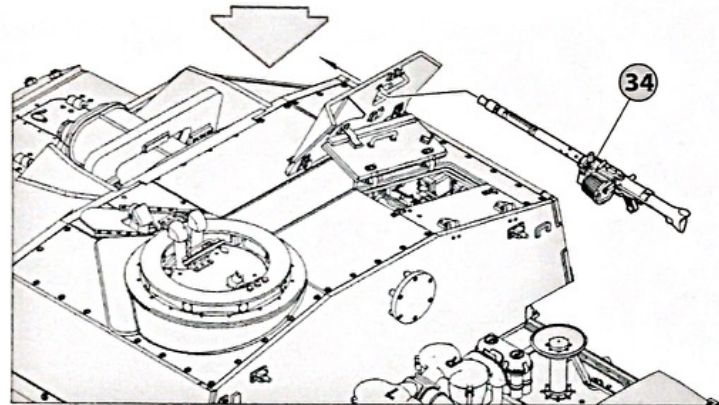
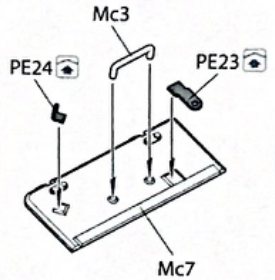

38

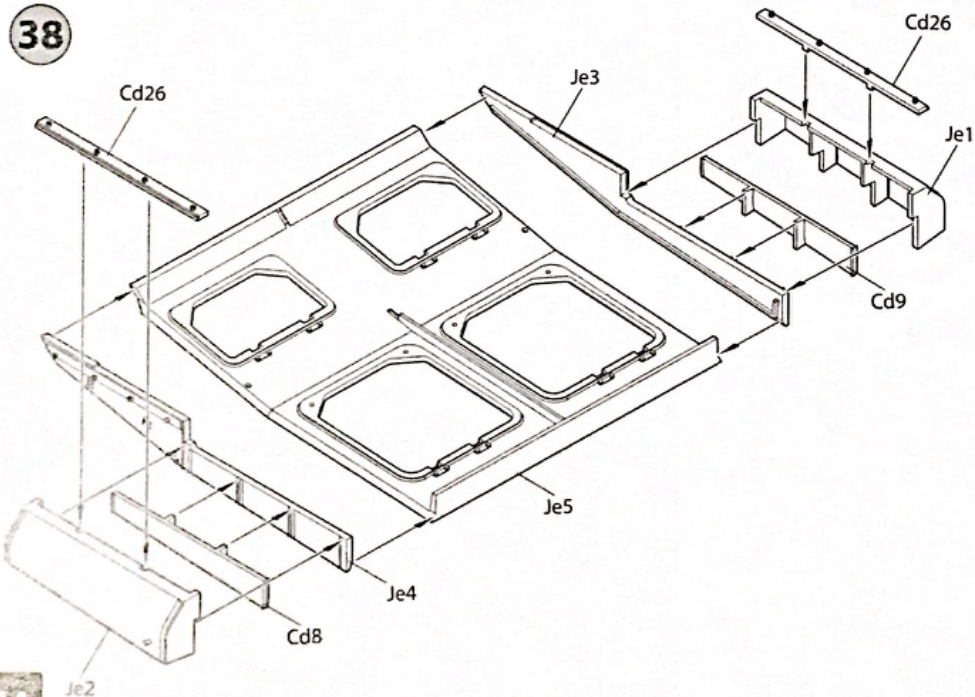

39

x2

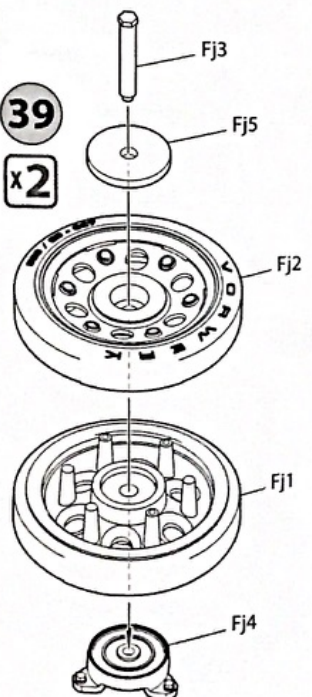

40

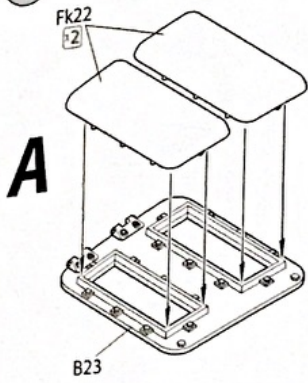

A

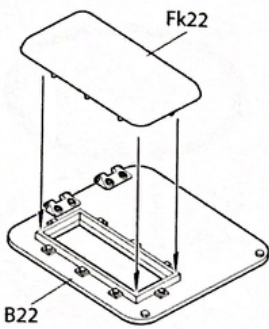

B

41

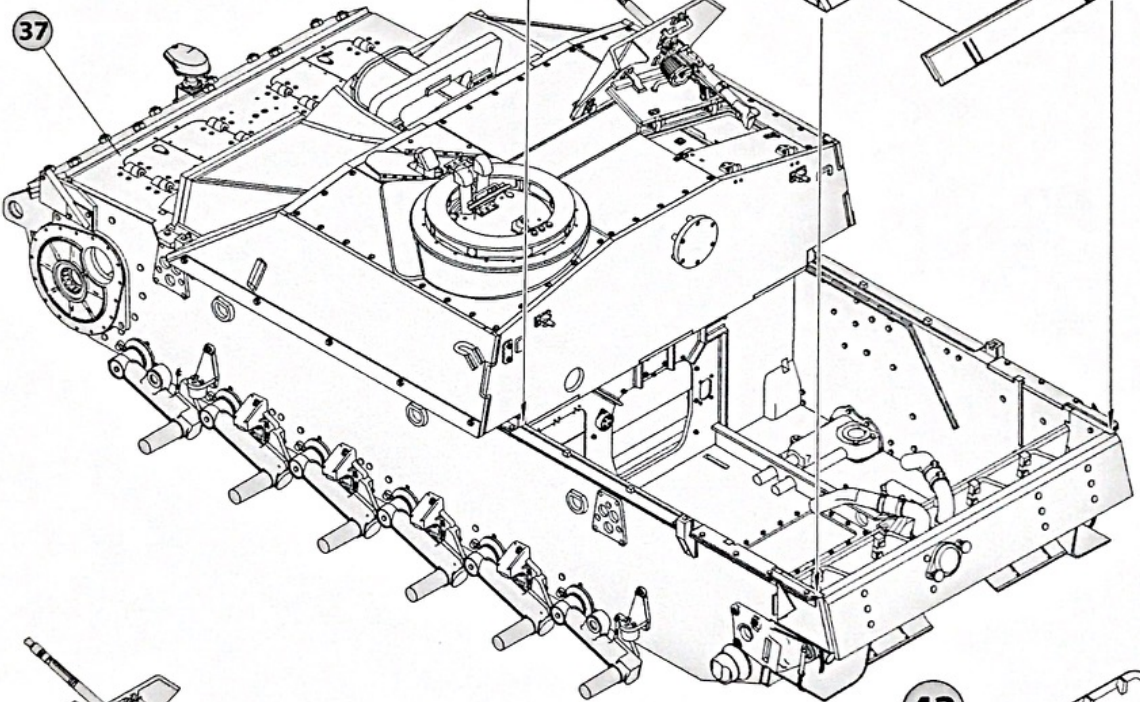
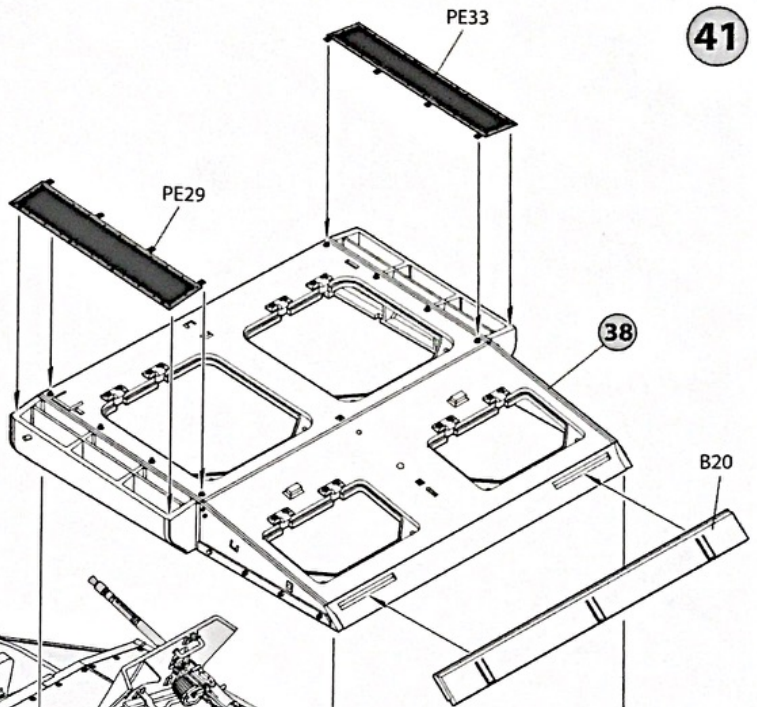

42

41

43

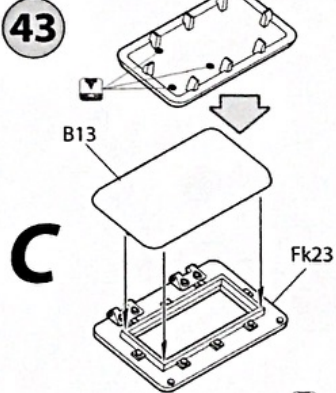
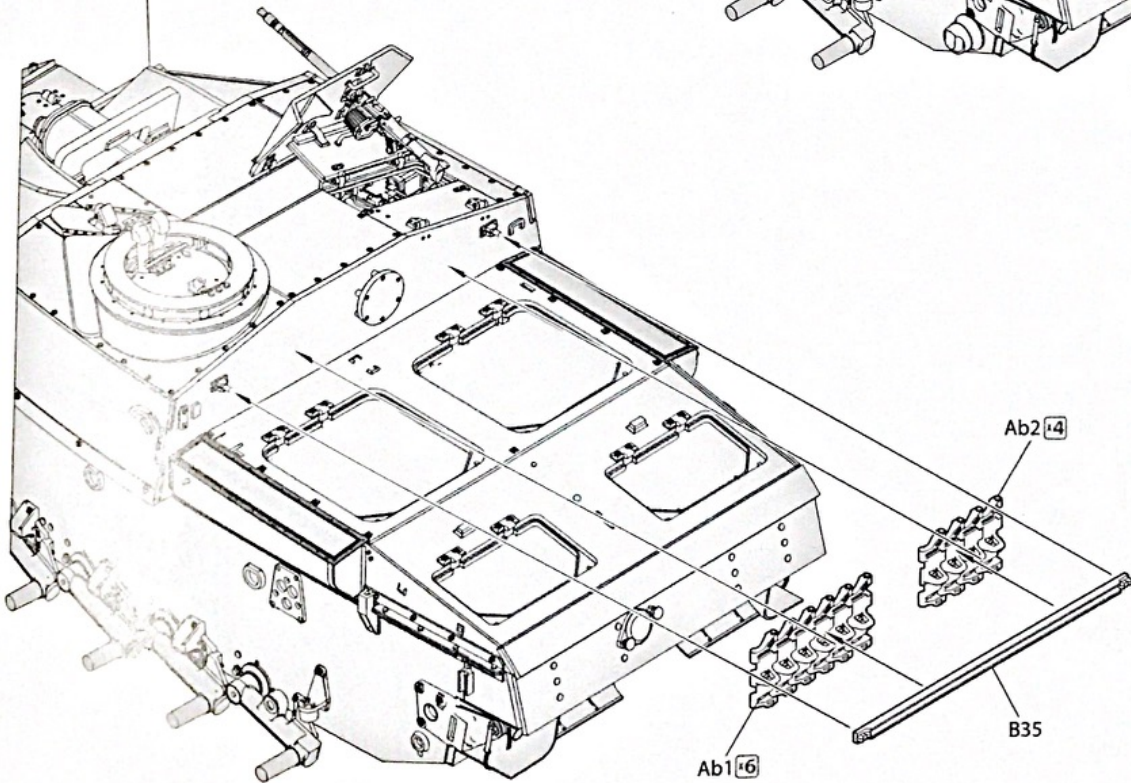

C

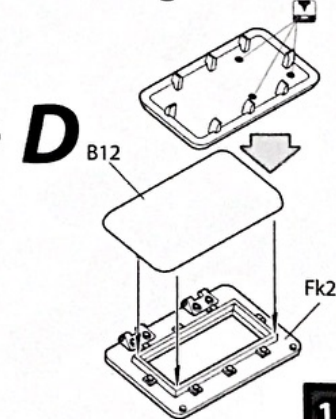

D

15

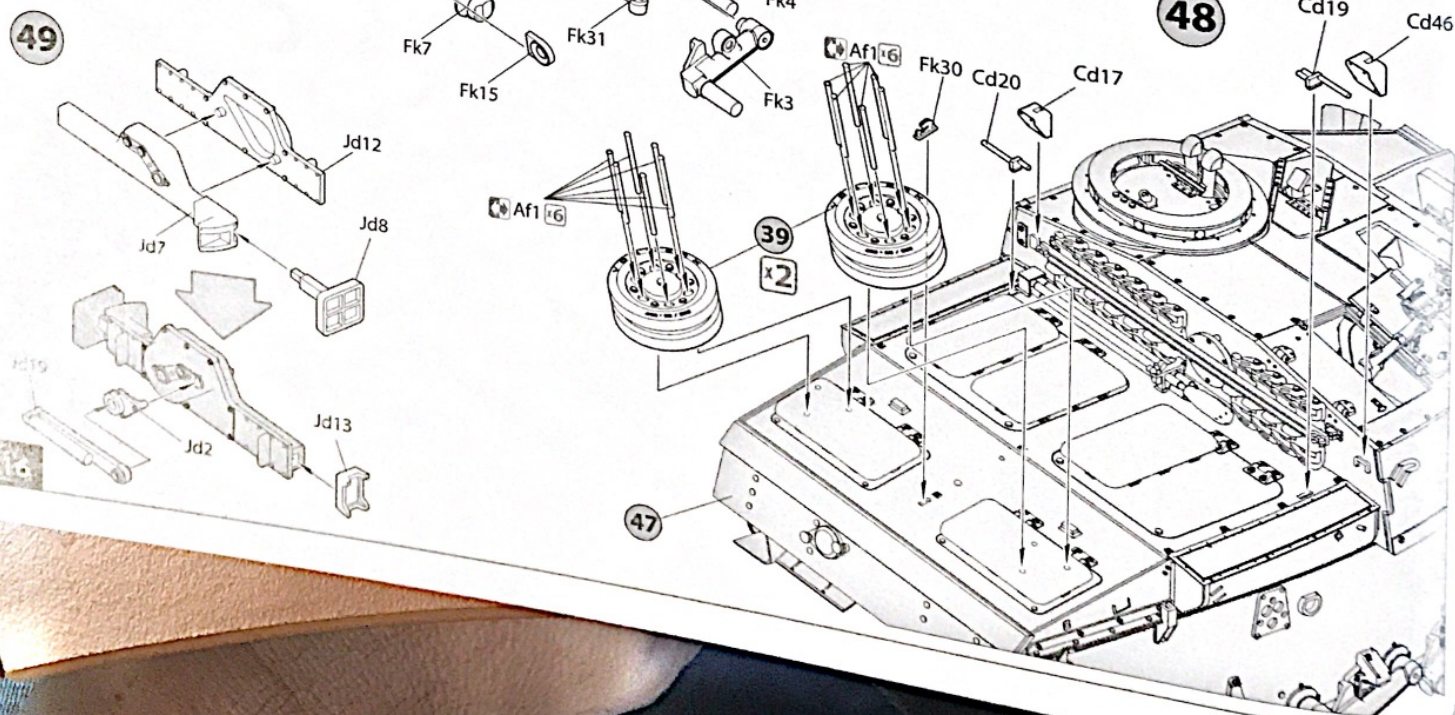
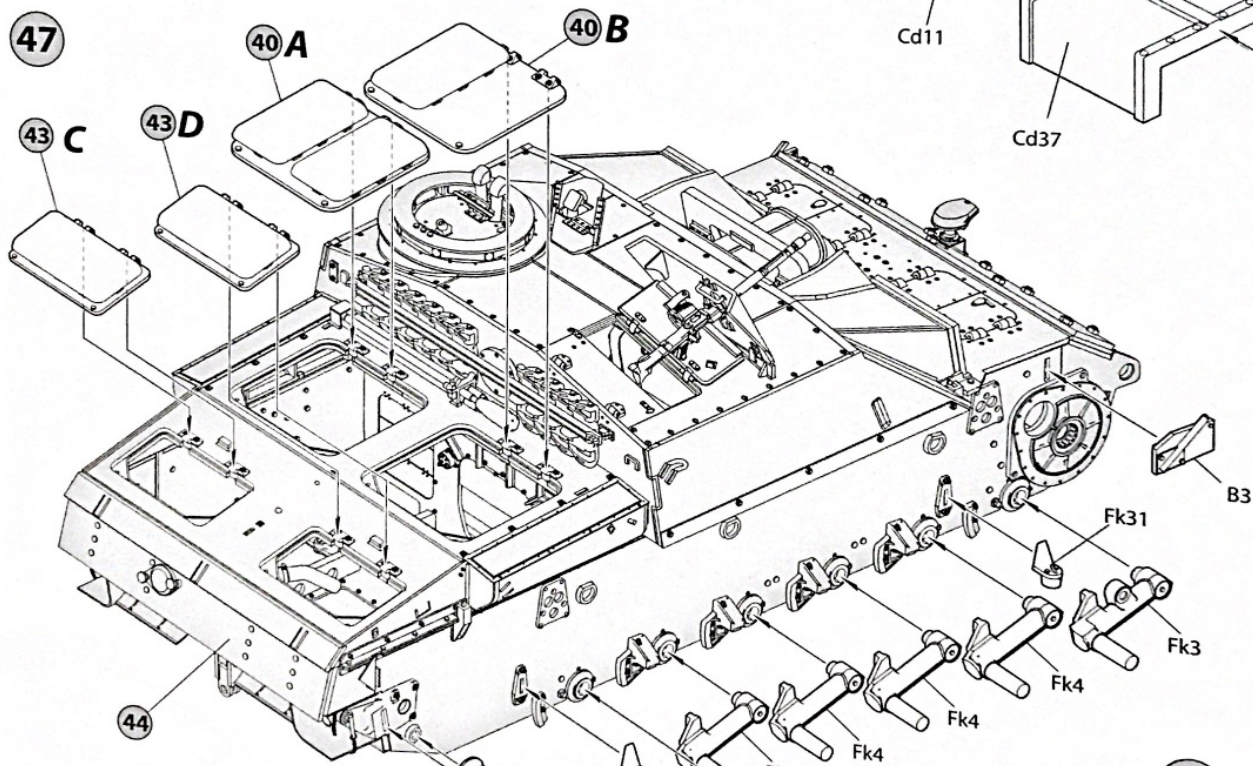
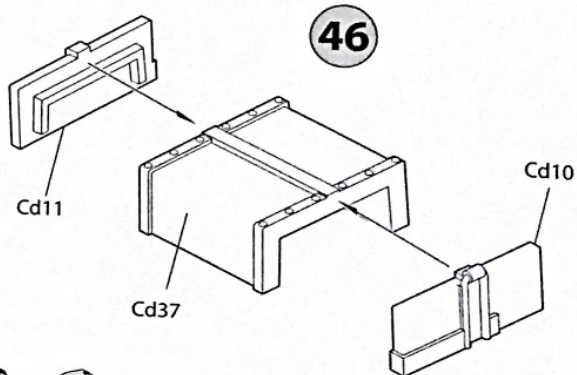
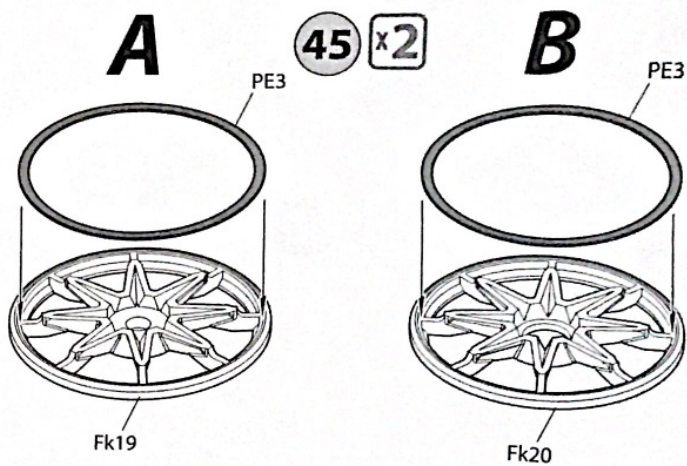
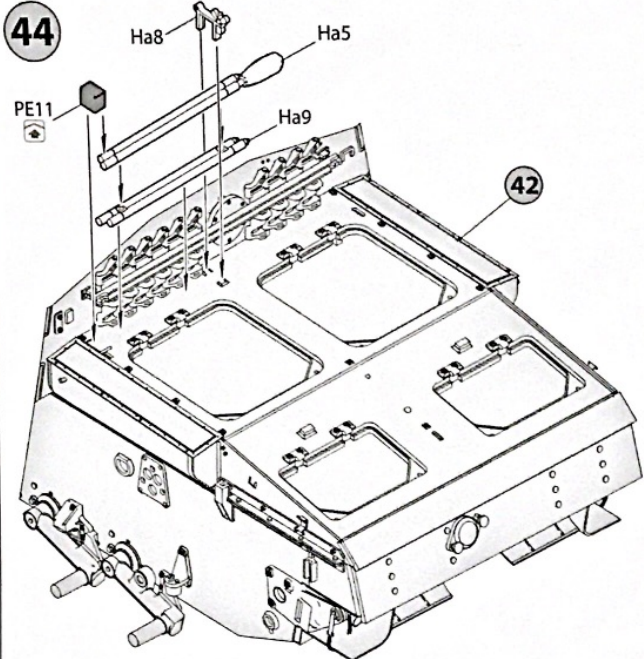

50

x12

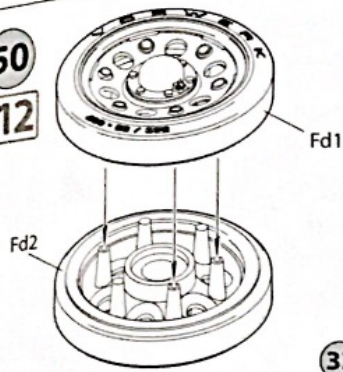

51

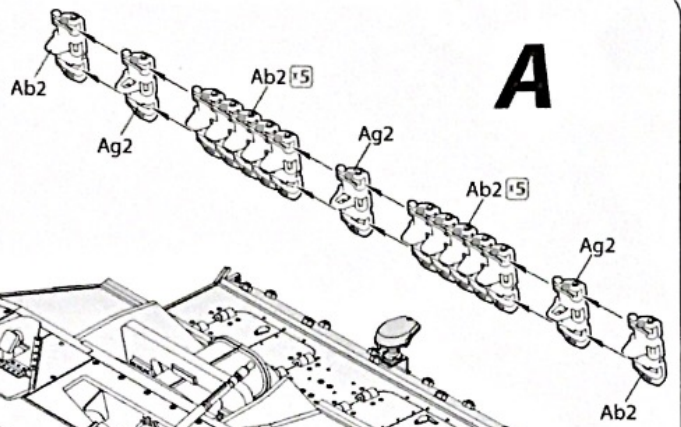

A

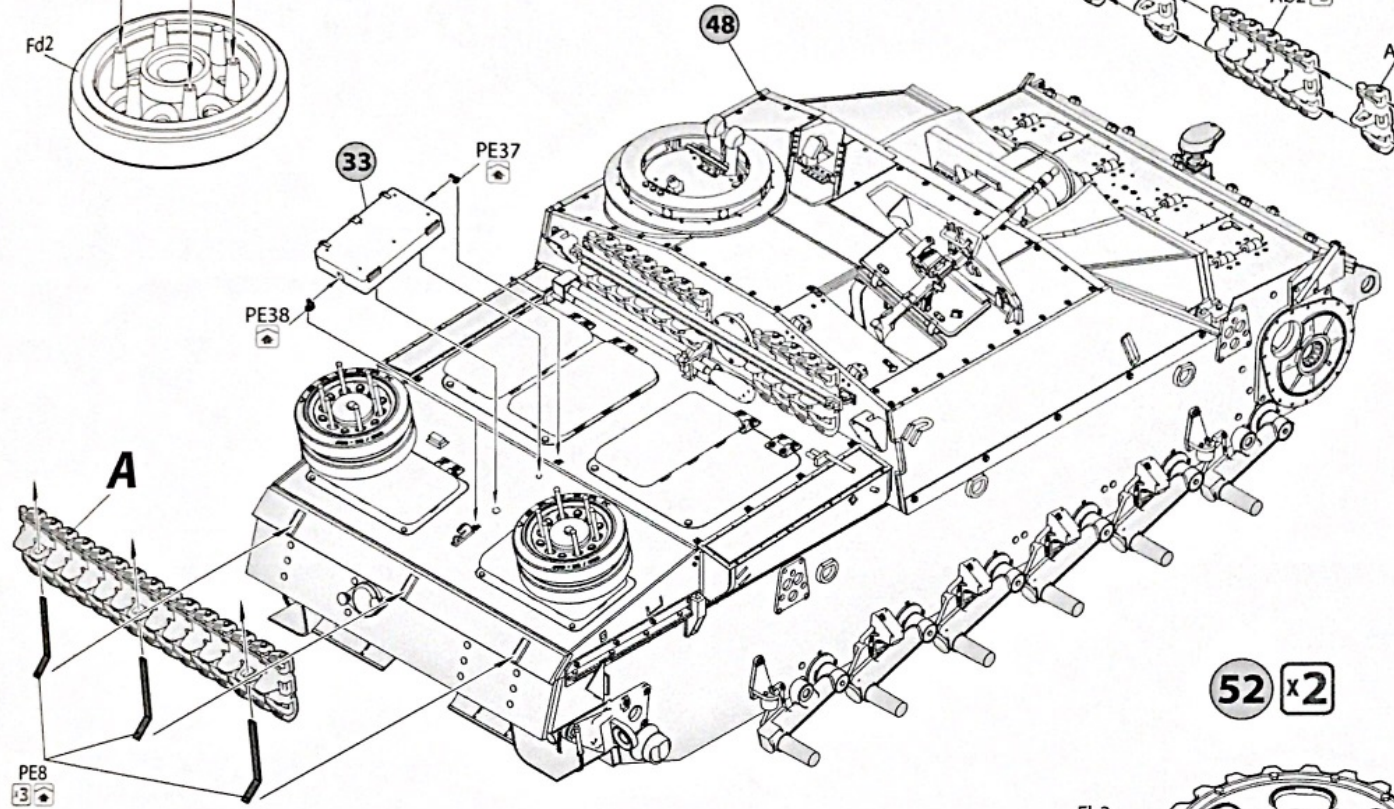

52 x2

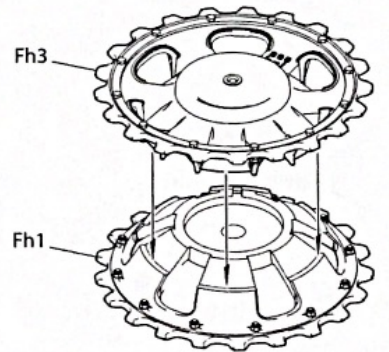

53

B

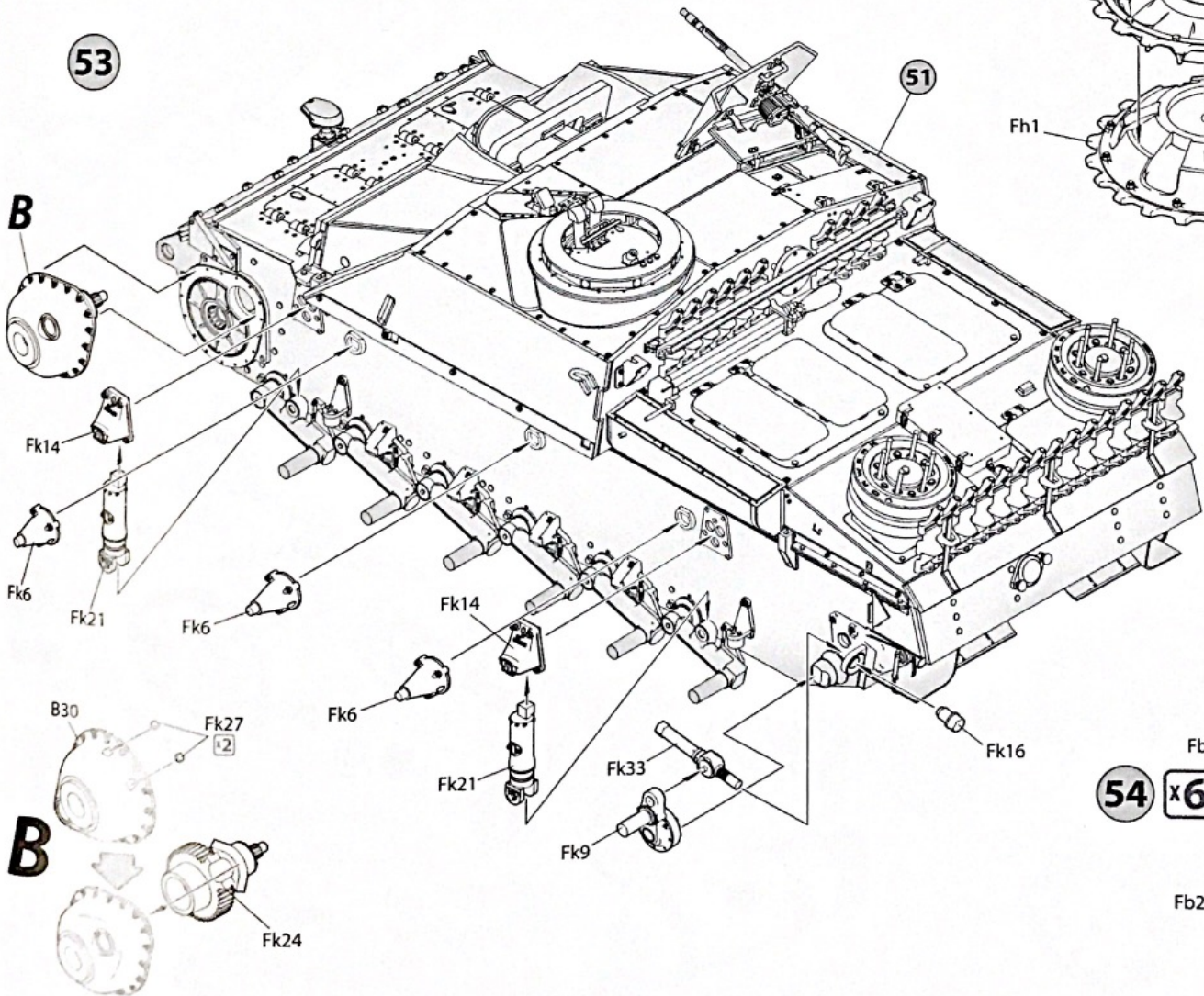

54 x6

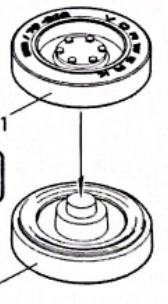

55

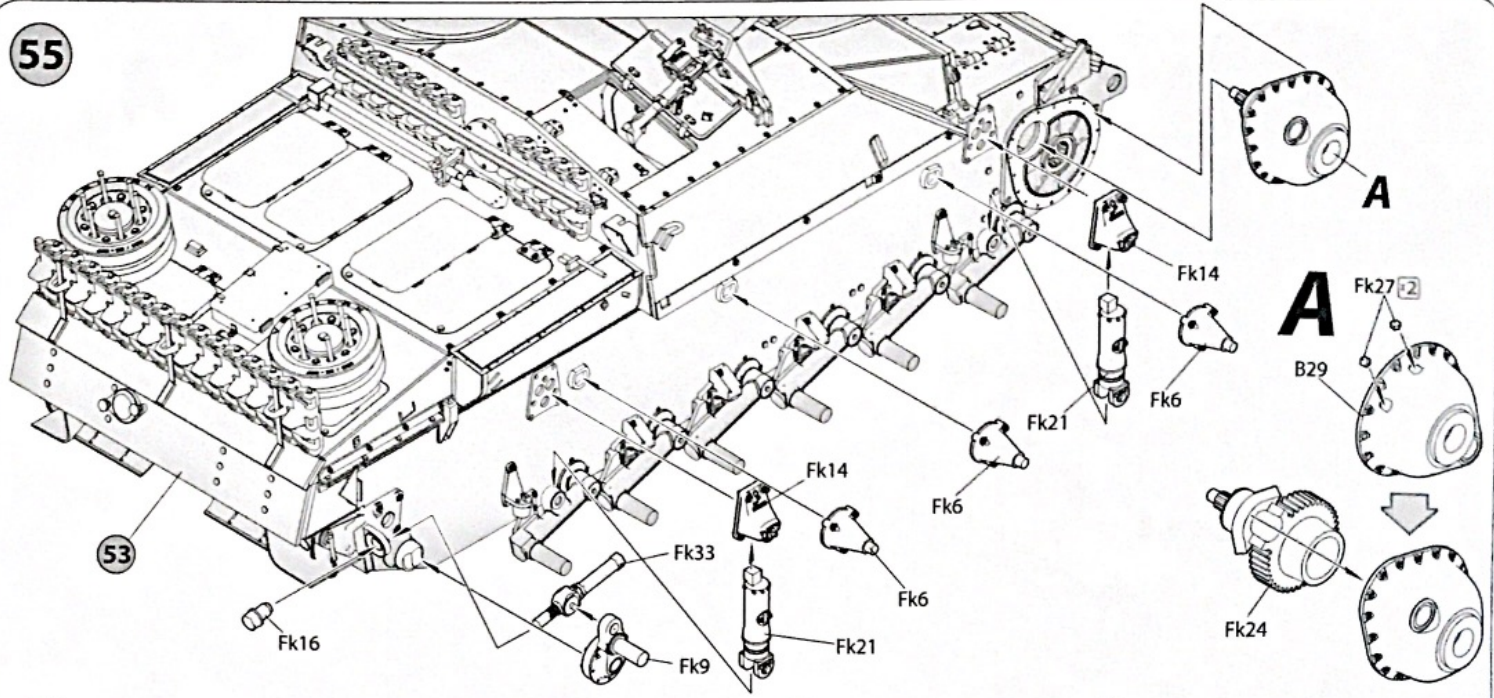

56

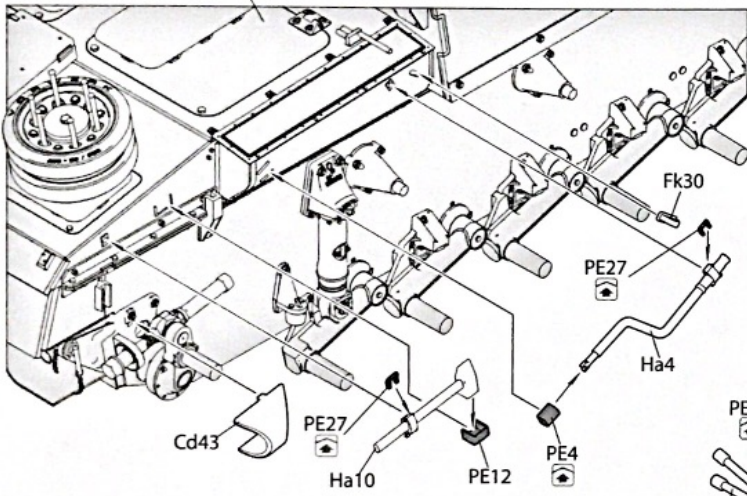

57

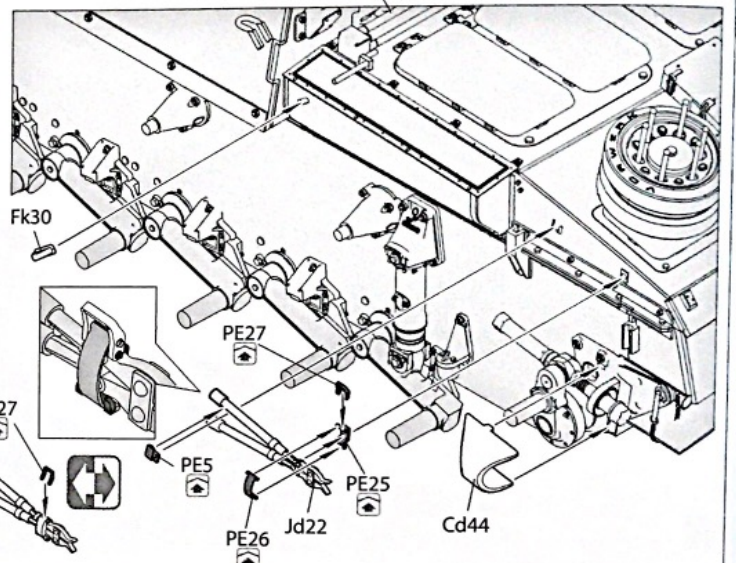

58 x2

Repeat on the reverse side

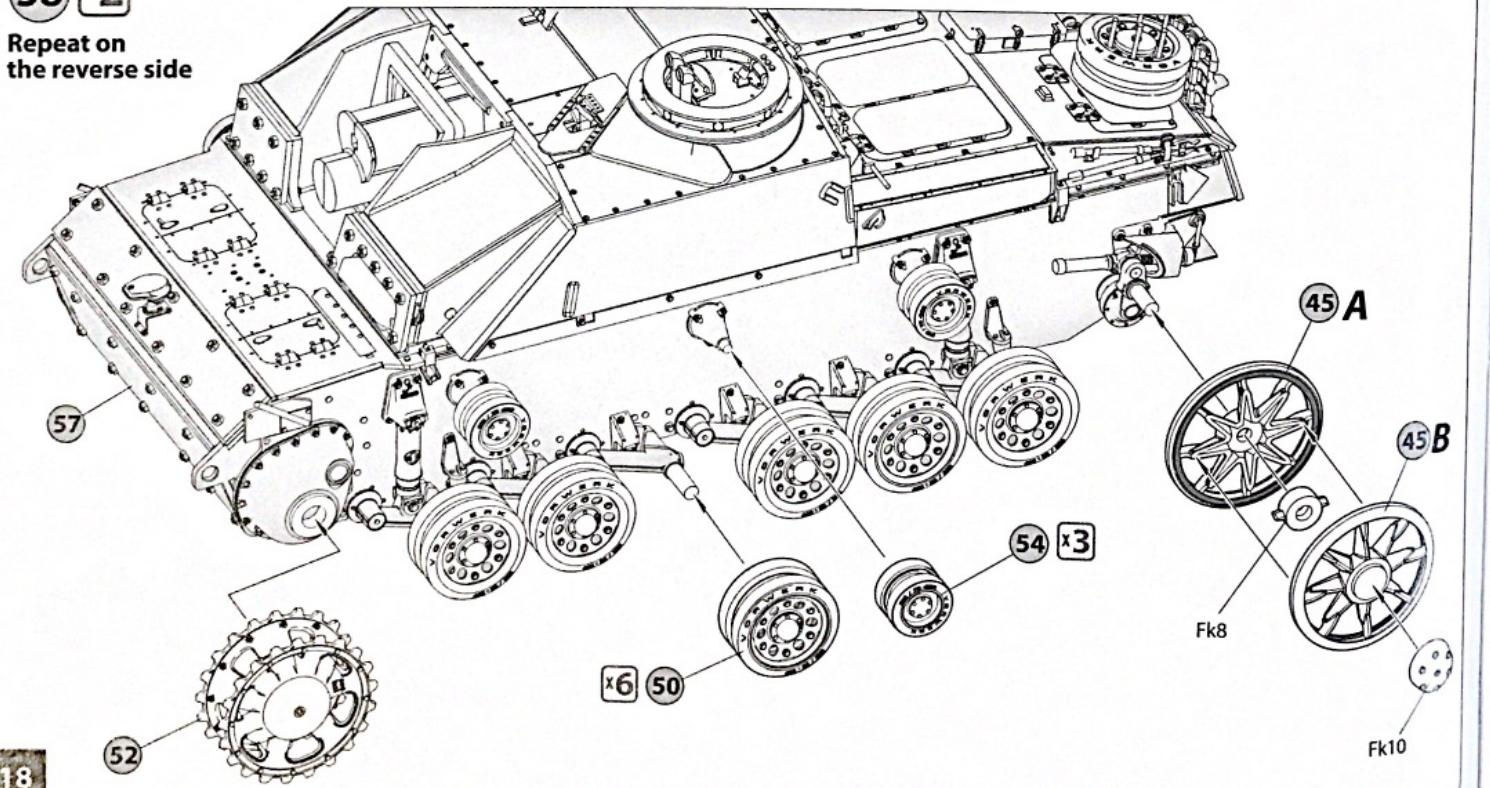

Each track links
contains 92-94 tracks

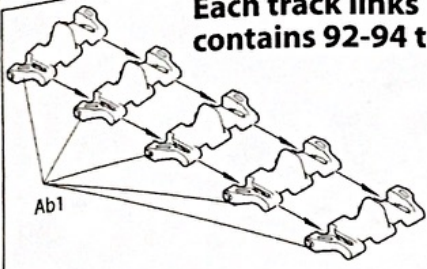

Each track links
contains 92-94 tracks

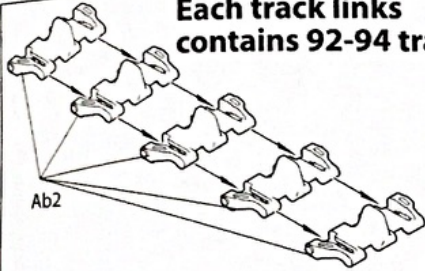

59

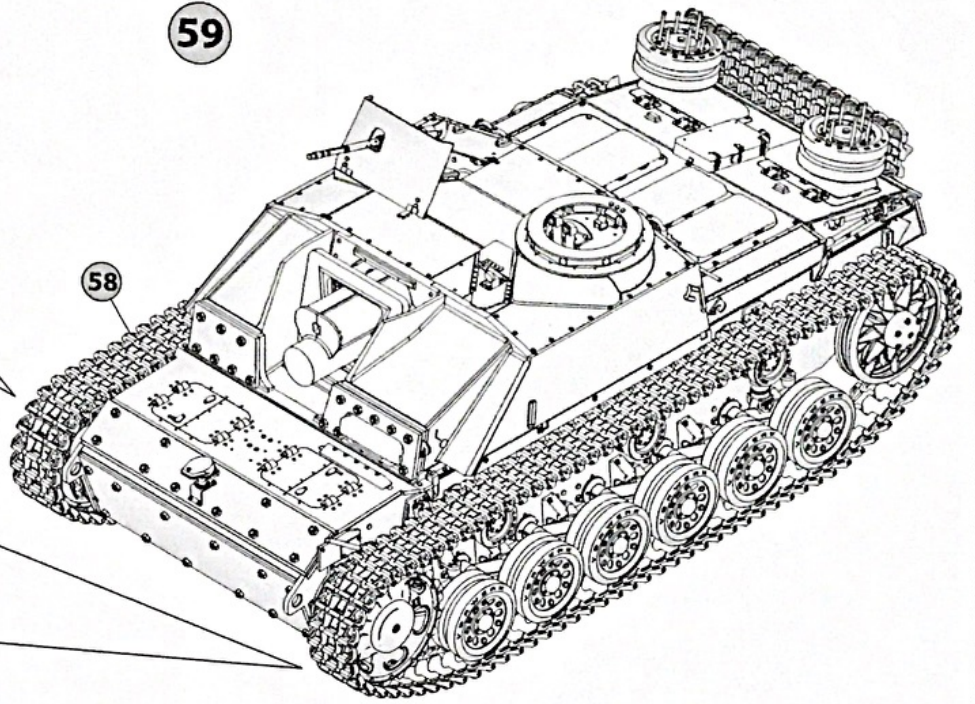

60

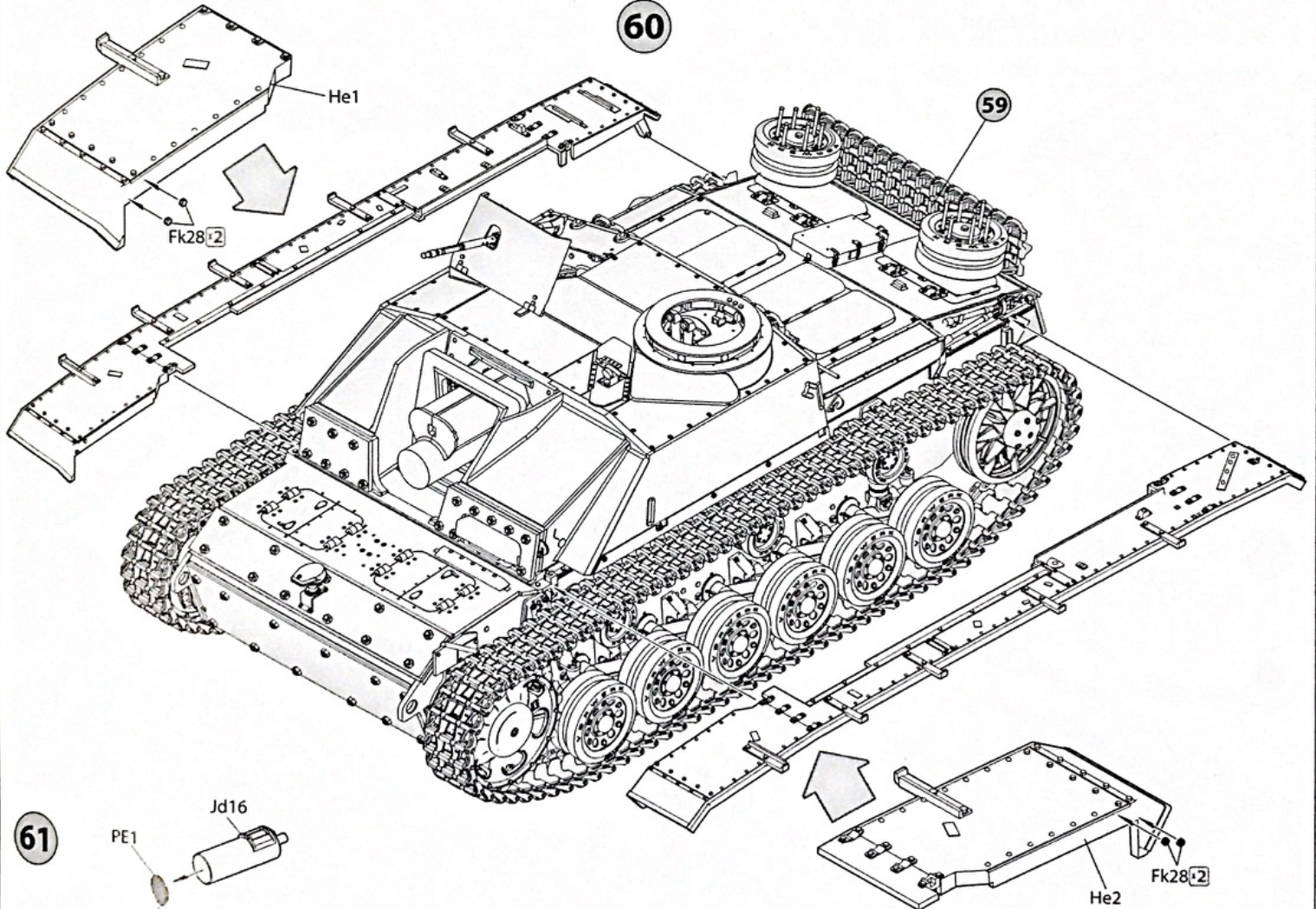

61

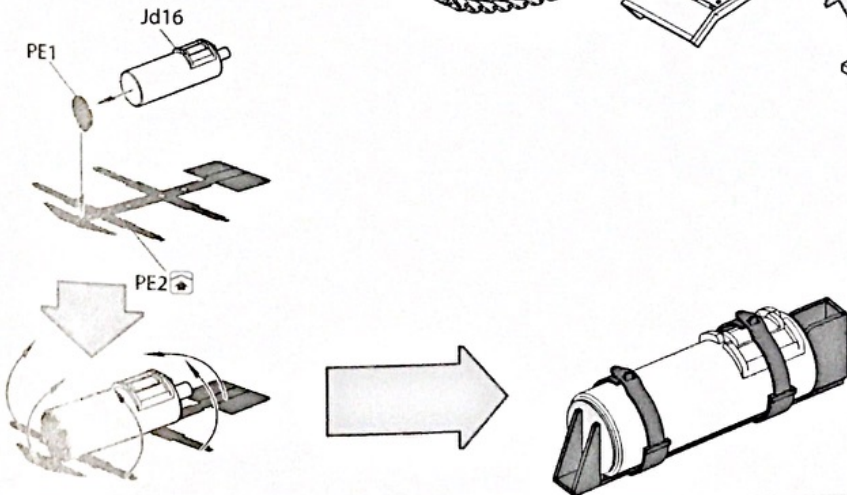

62

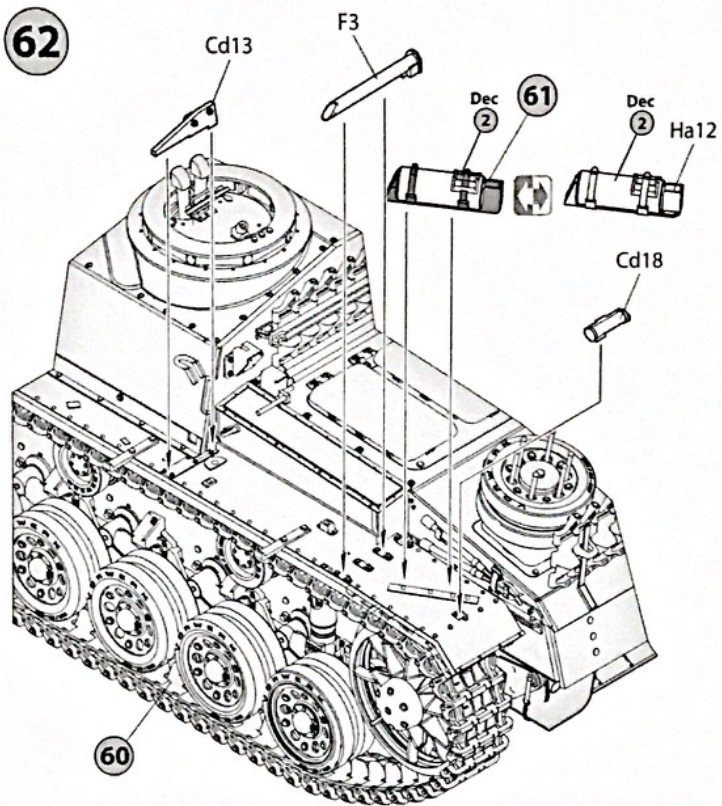

63

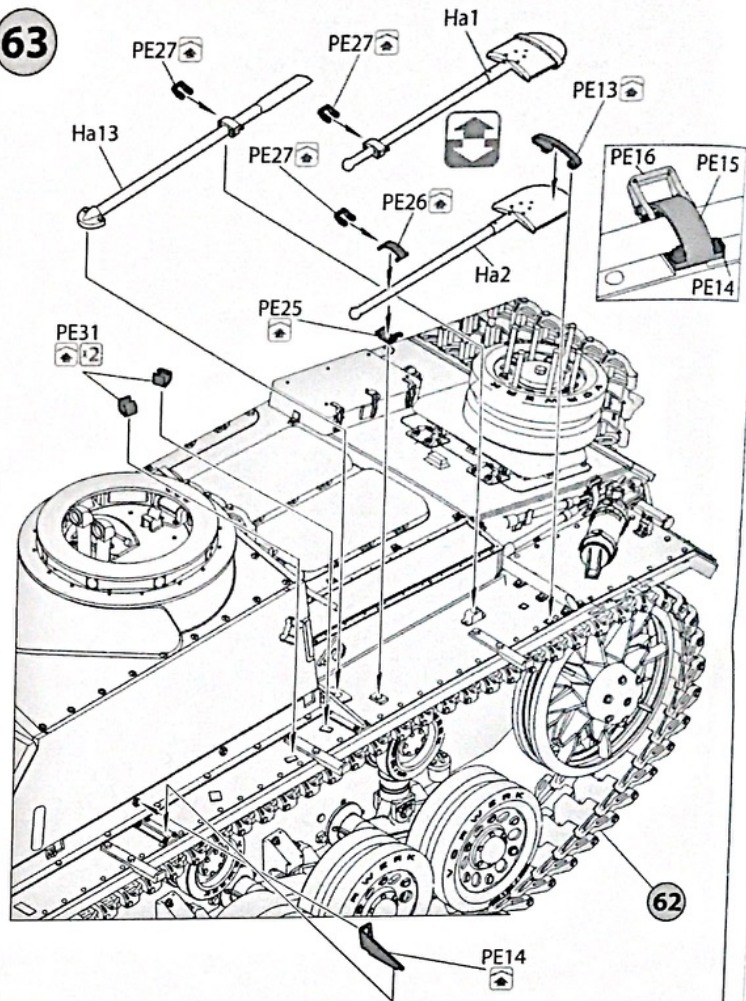

64

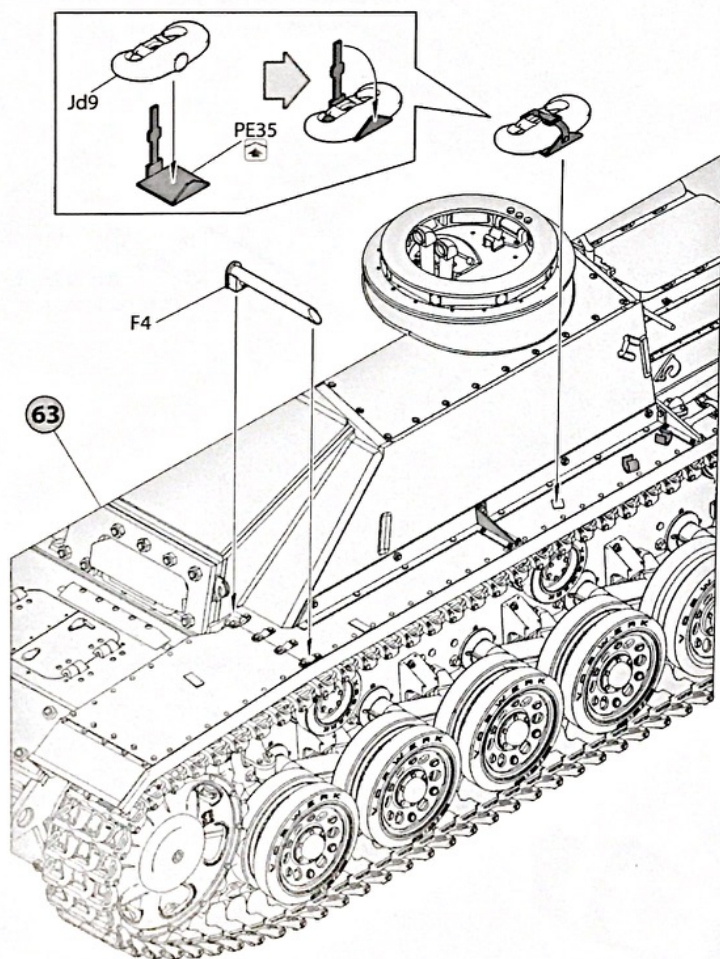

65

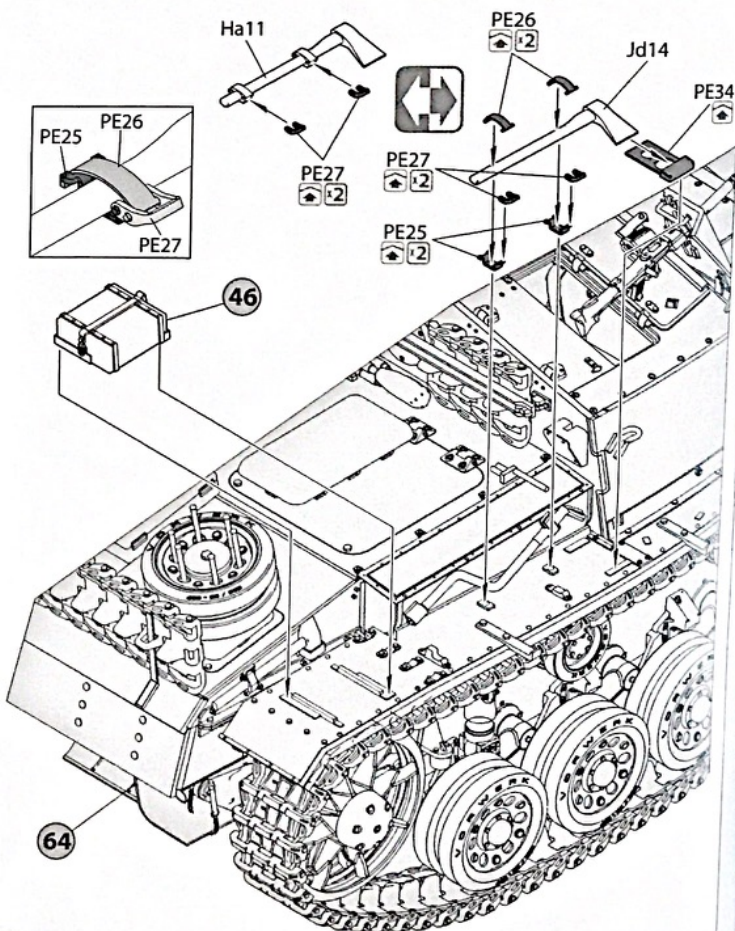

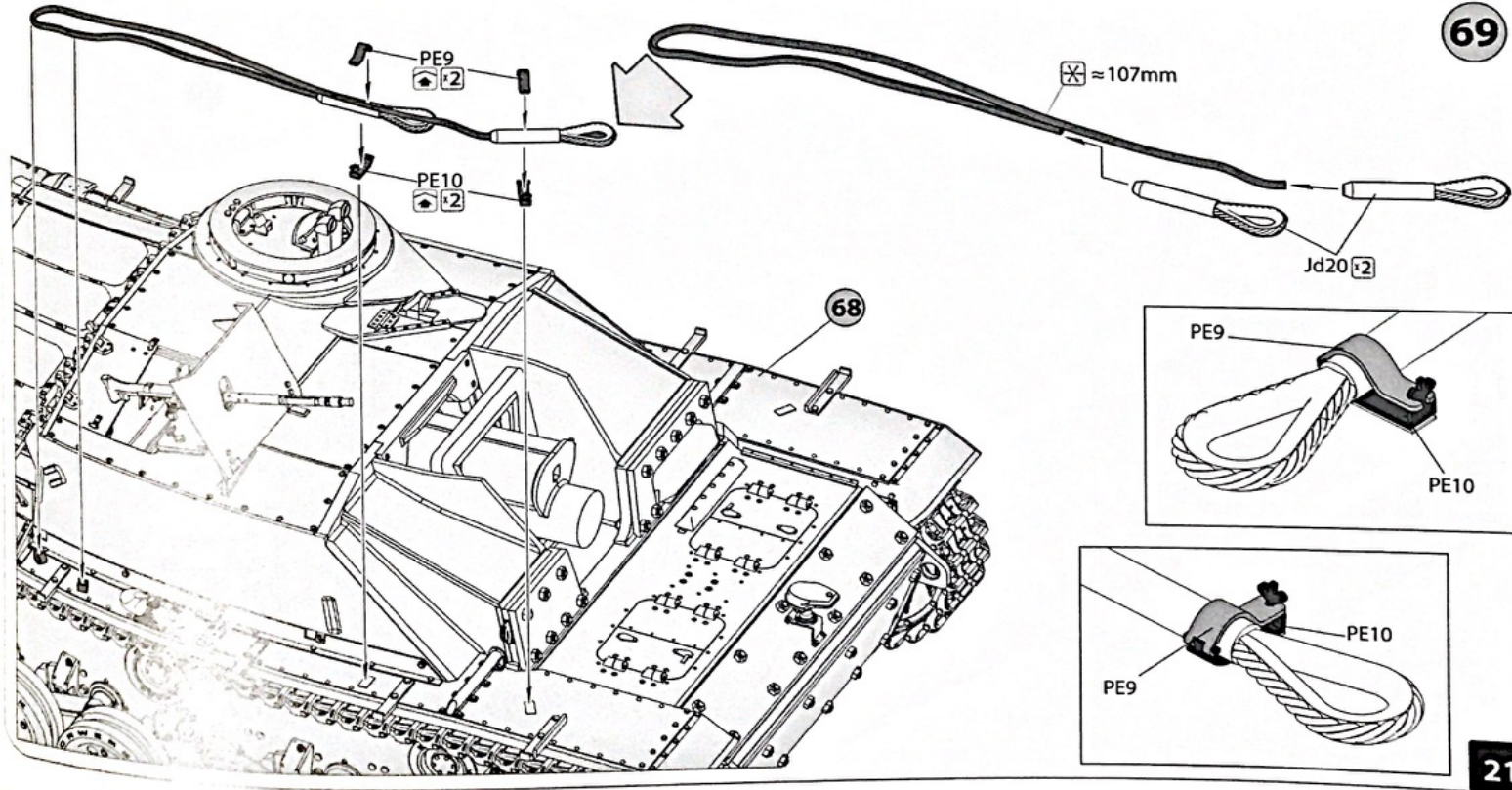
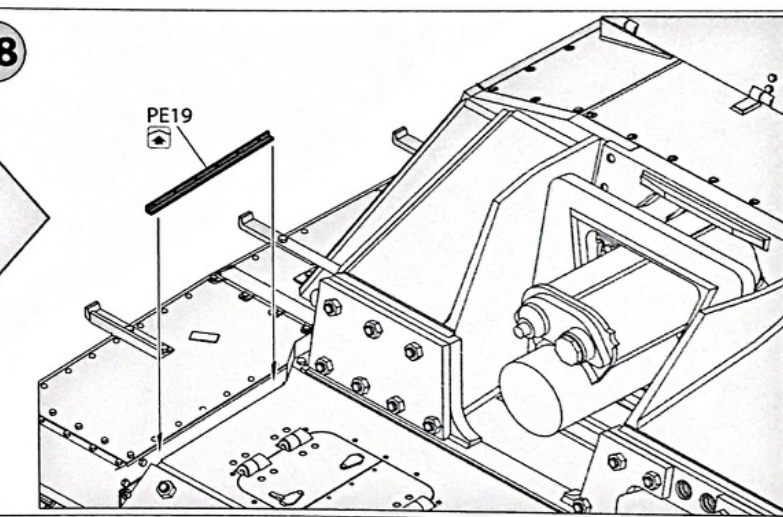
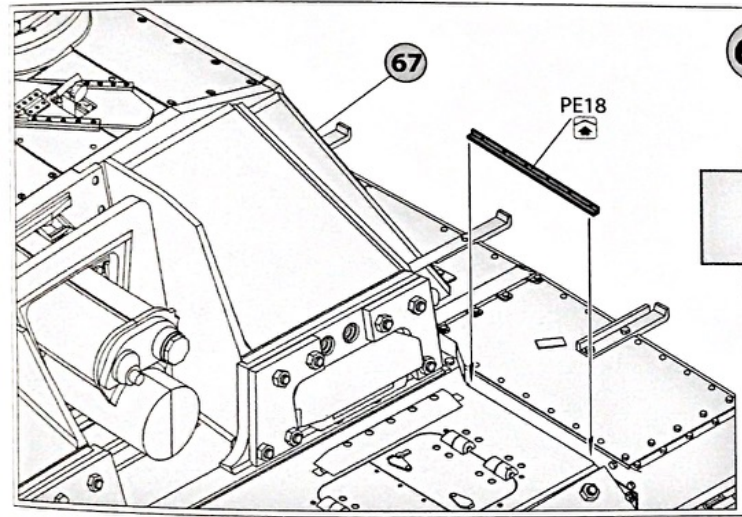
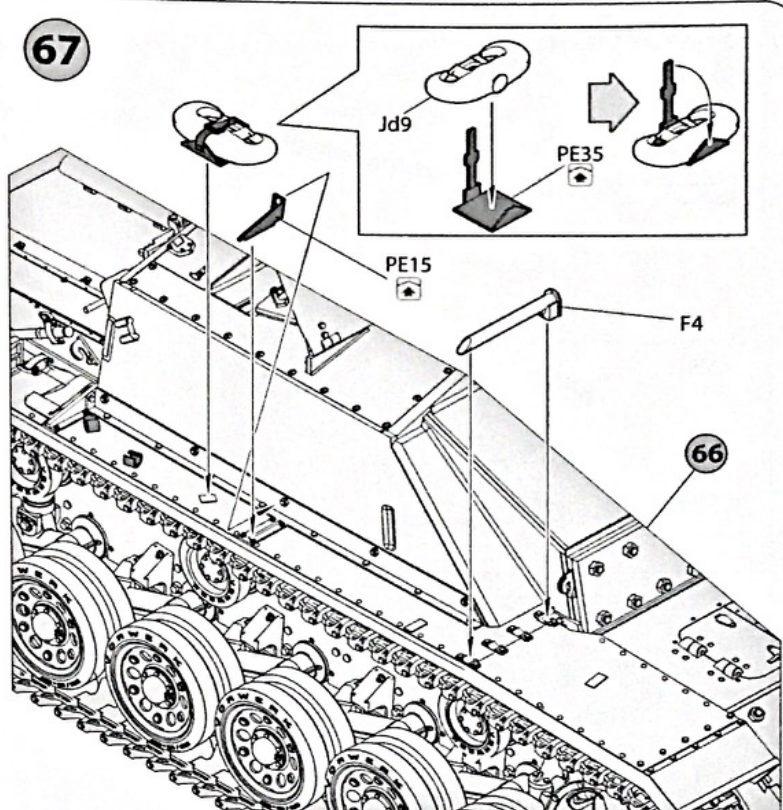
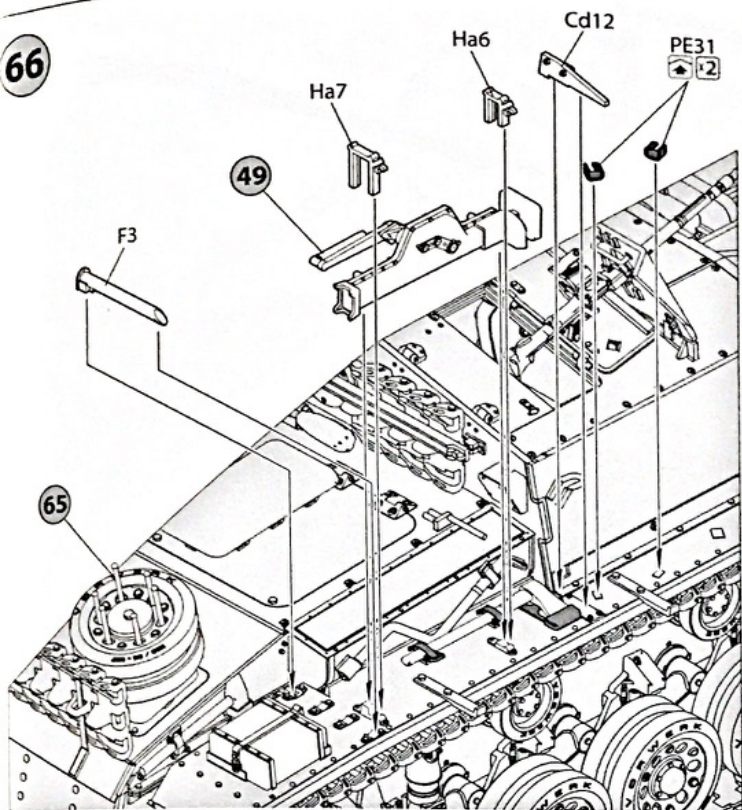

70

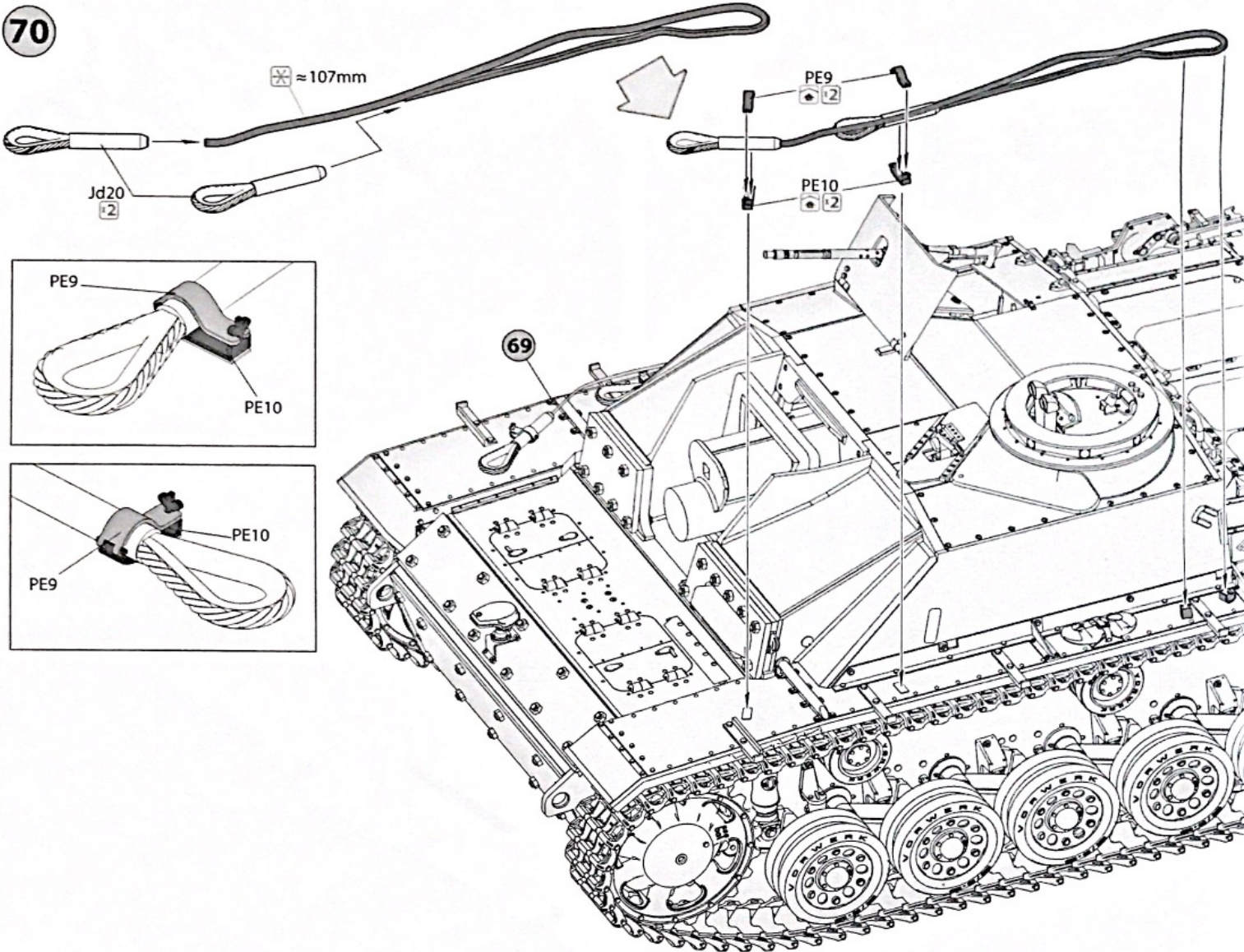

71

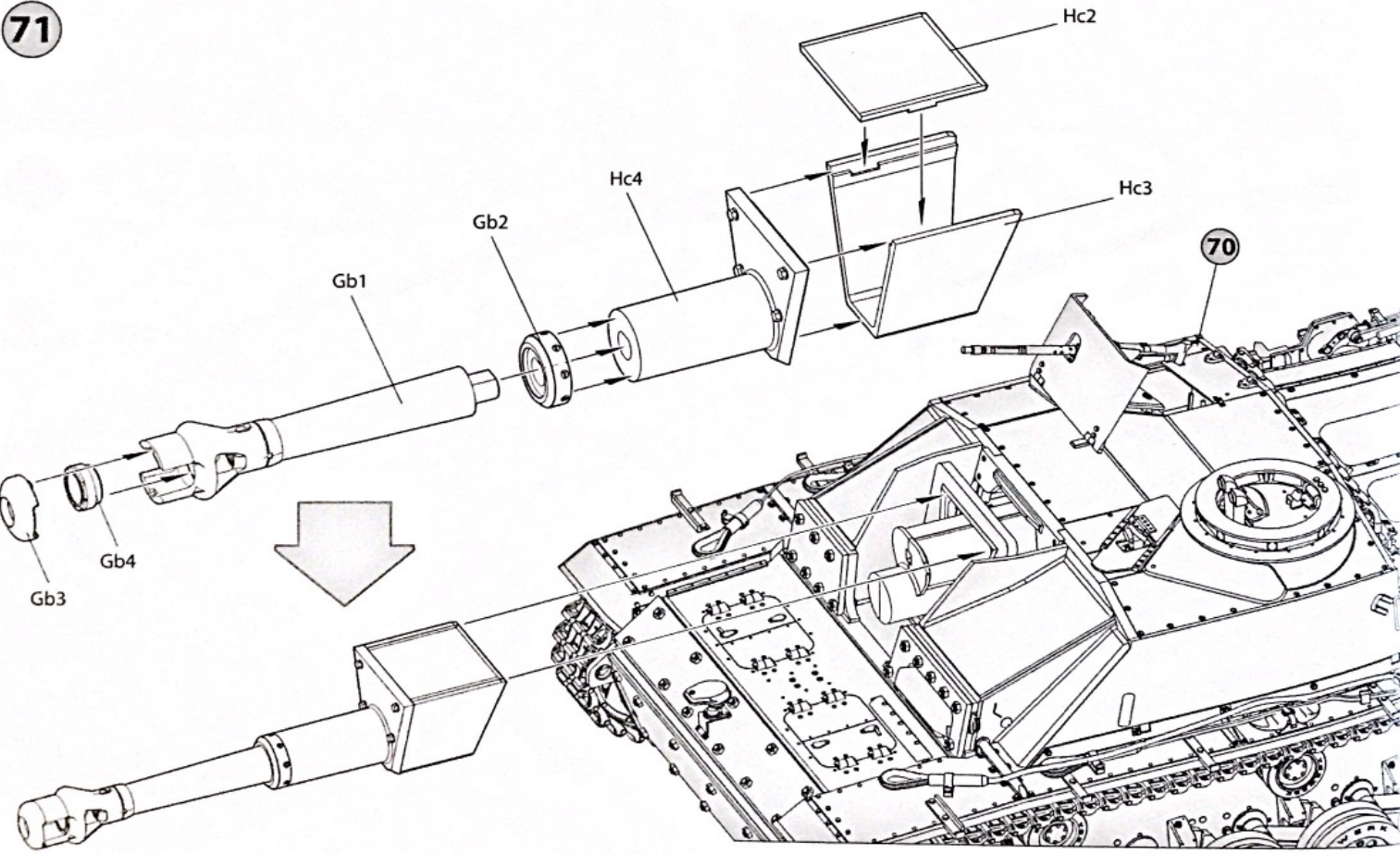

72

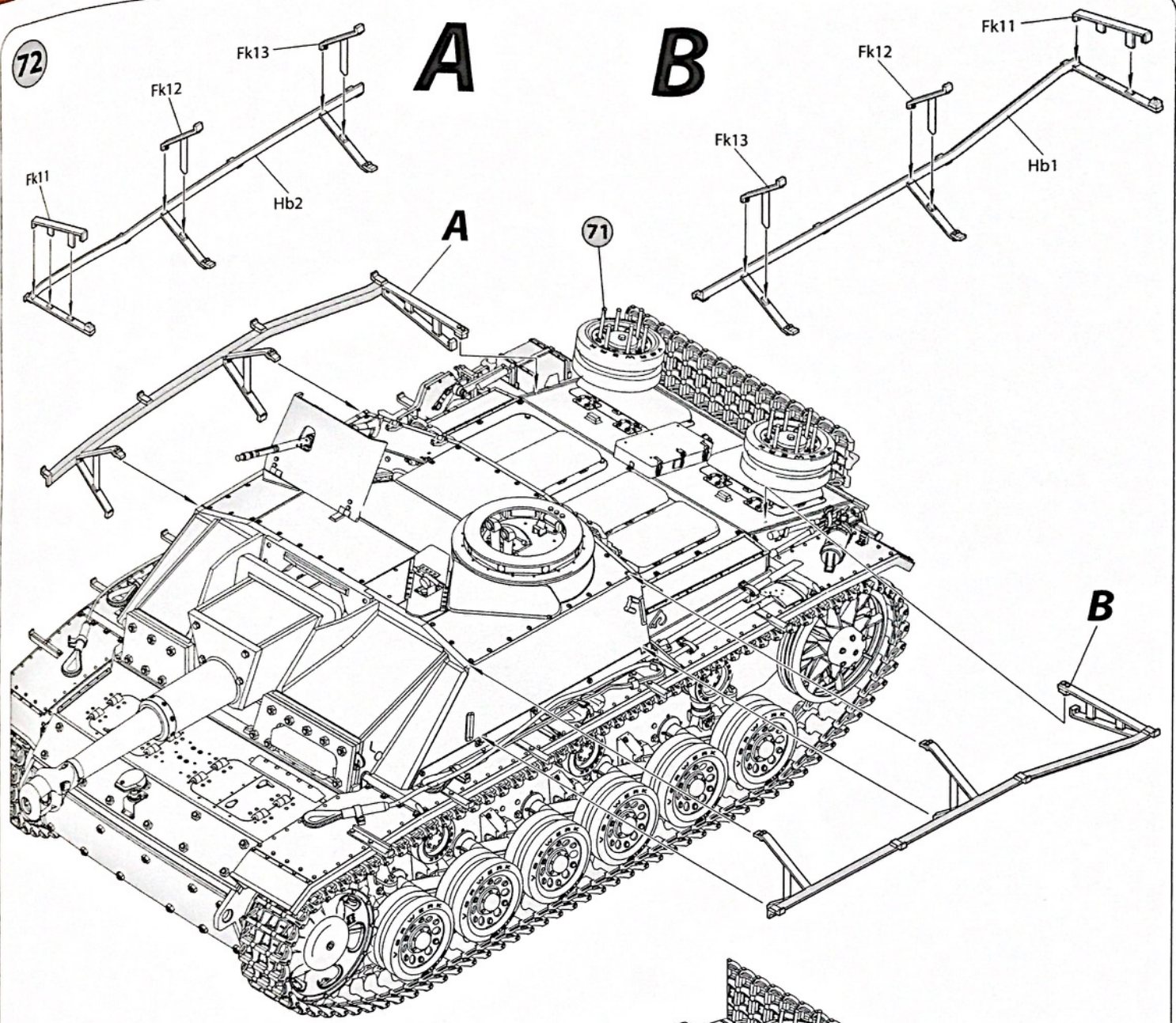

73

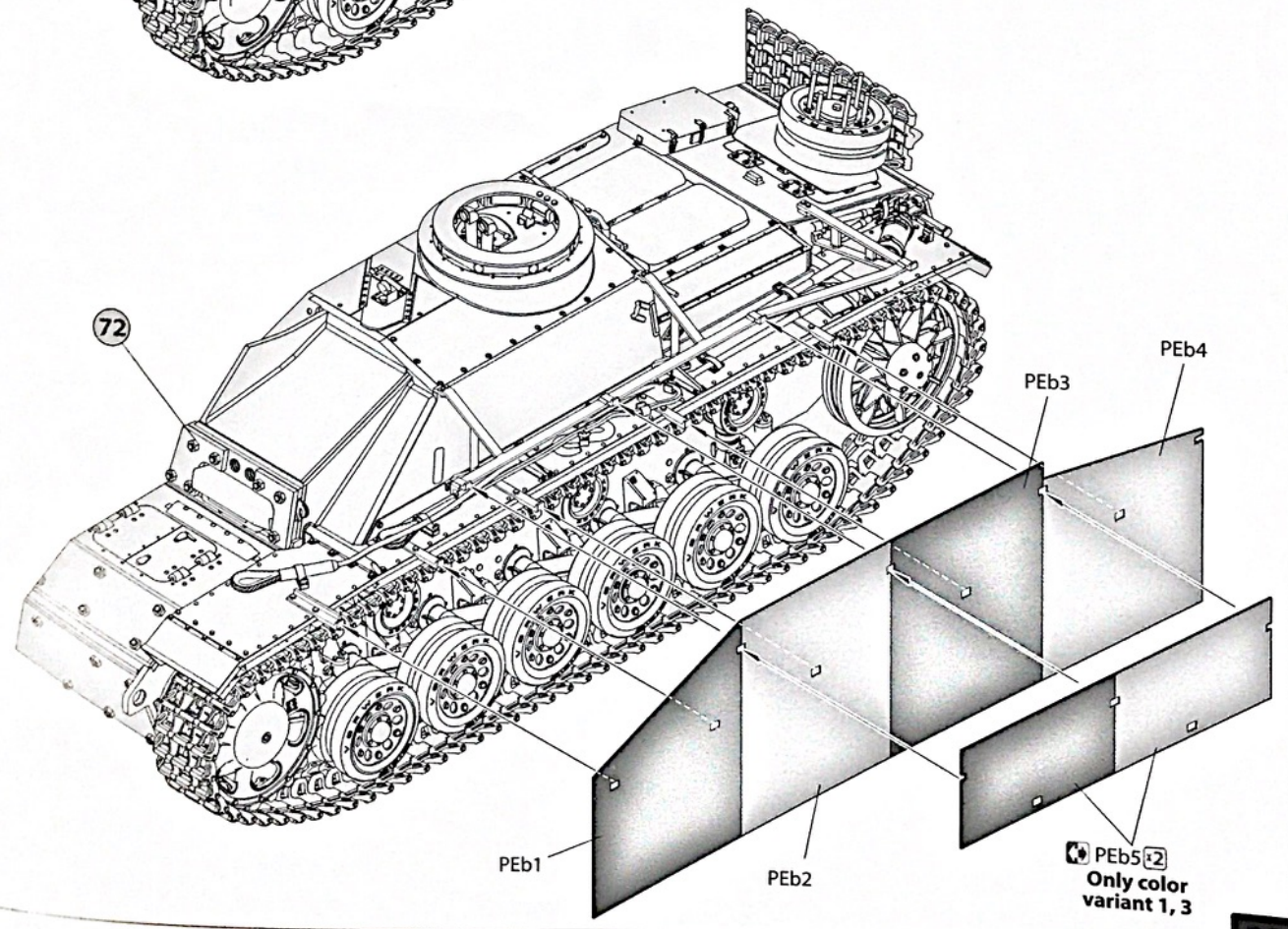

74

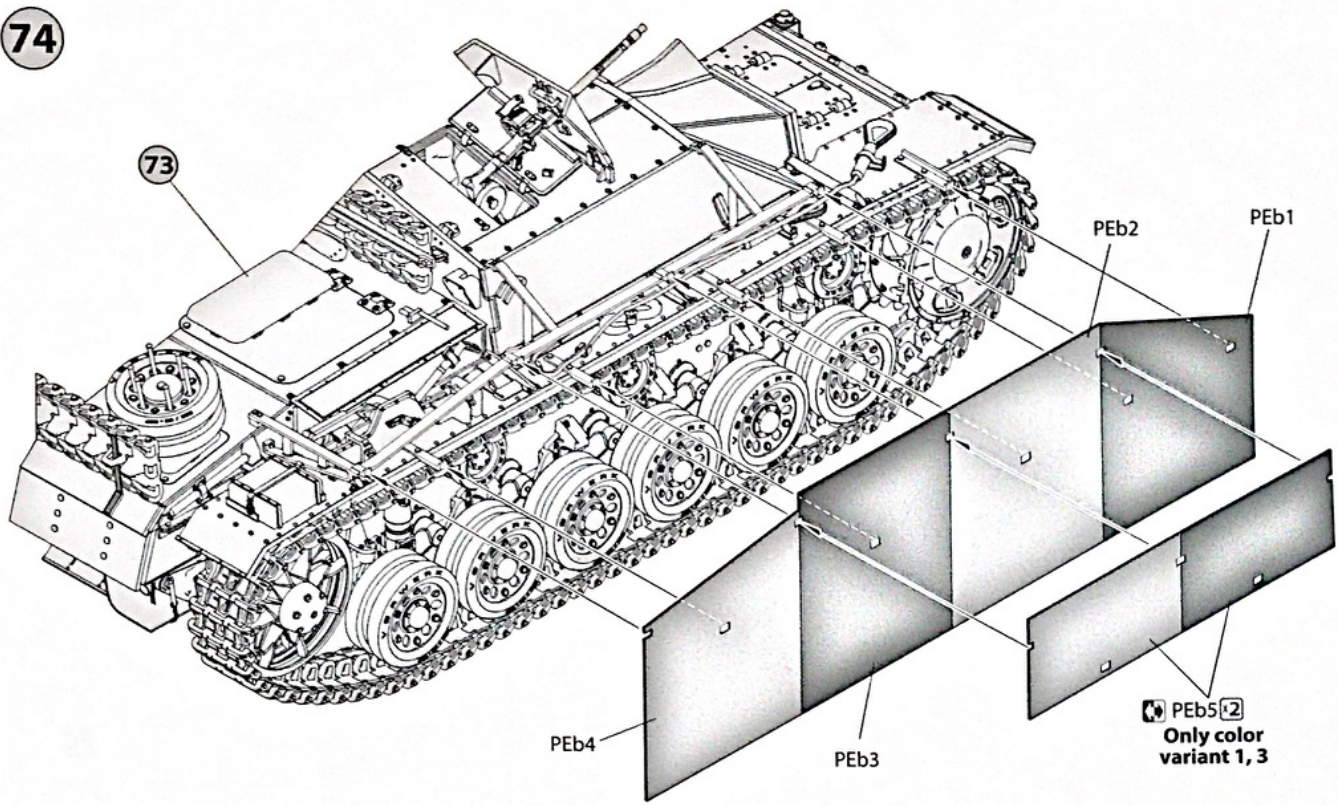

75

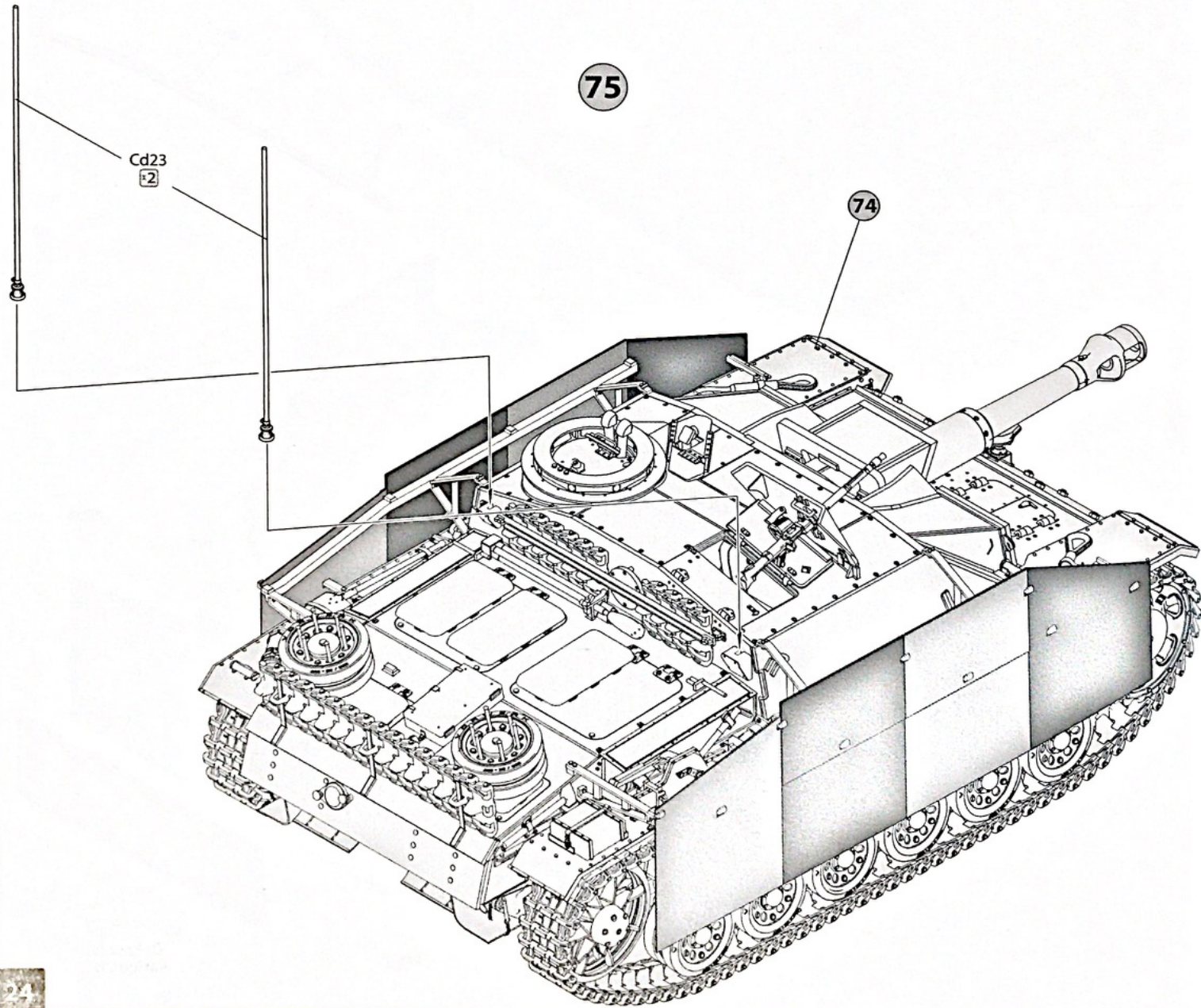

4 245 StuG. Abt., Eastern Front, Summer 1943.

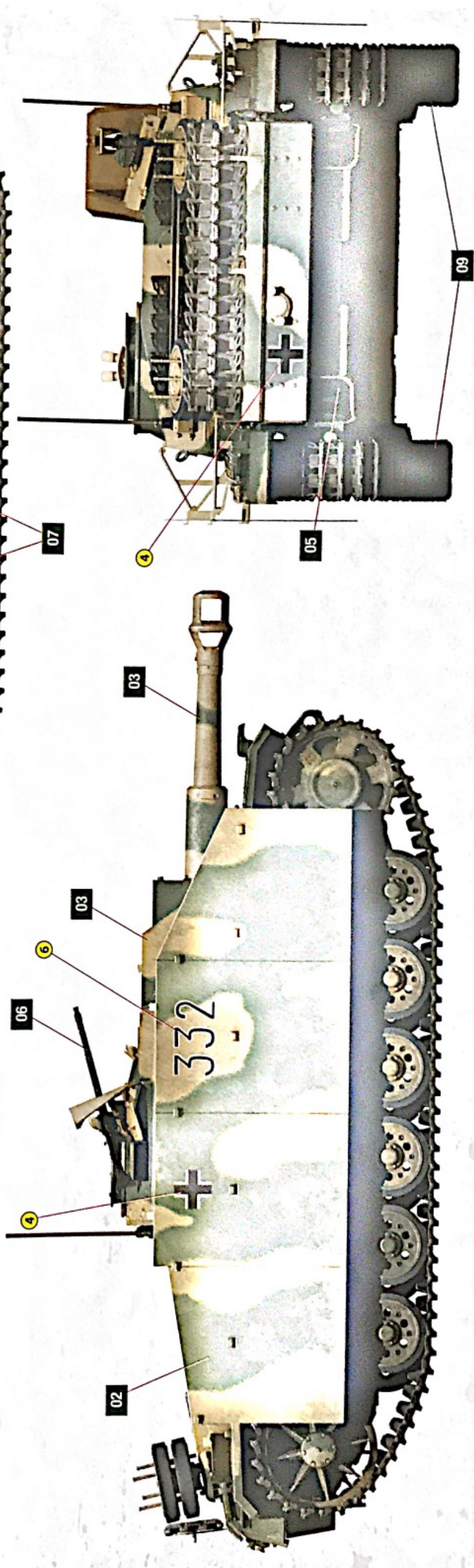
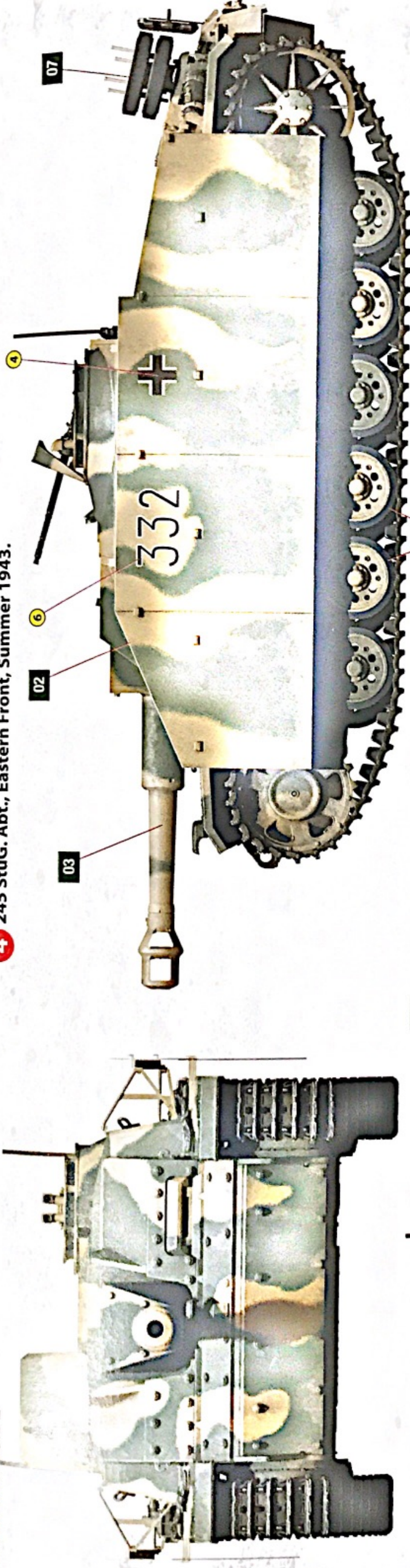



StuH 42 Aust. G

Early Prod.

May-June 1943

SCALE

1:35

PAINTING GUIDE

5 StuG Abt 245. Eastern Front, Summer 1943.

