

1:35 '39-'45 SERIES

KIT NO. 6254

Sd.Kfz. 182 KING TIGER HENSCHEL TURRET BATTLE OF THE BULGE

sPzAbt 501



Rostayn 05



Project supervised by HIROHISA TAKADA. Technical drawings provided by MINORU IGARASHI.

Ax2

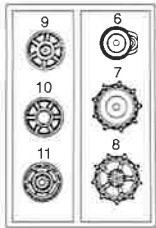

Bx2

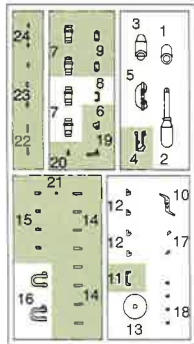

C

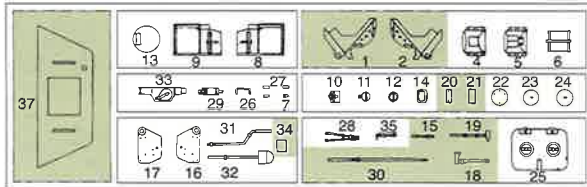

D

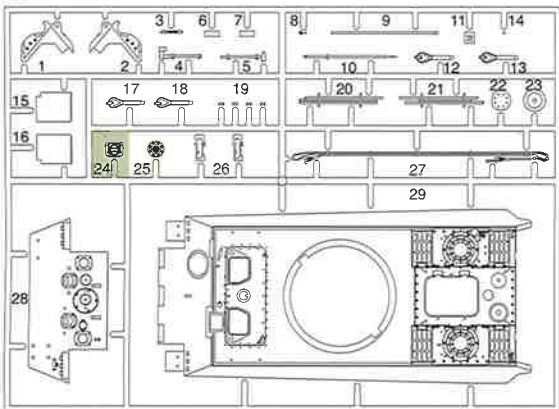

N

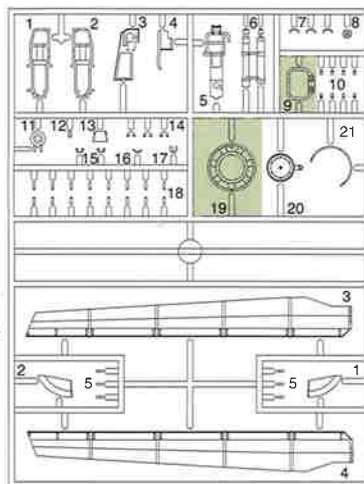

K

S (420mm metallic cable wire)

MagiTrack™
PATENT REGISTERED
実用新案登録済み

Yx6



Zx6

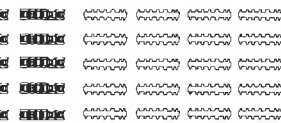

Gx3

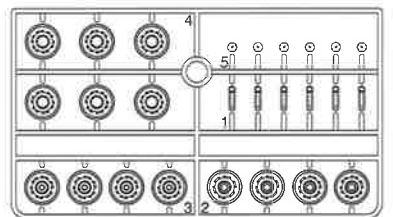

I

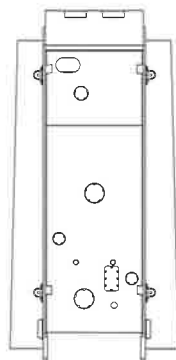

MA (Photo-etched Parts)

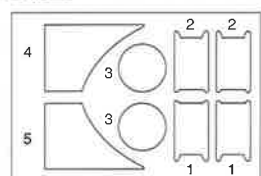

MB (Metal Parts)



MC (Photo-etched Parts)



O

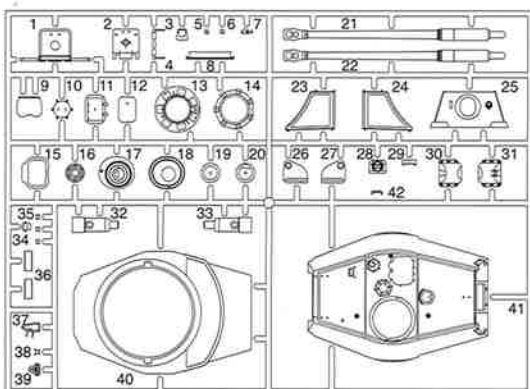

x2



この部品は使用しません
Parts not for use.
Telle werden nicht verwendet.
Pièces a ne pas utiliser.
Parti nin ulizzati.
不需要使用的部件

組立ての注意

- ・接着剤や塗料は火の、近くで使わないでください。使う時はときどき窓を開けて換気につまきましょう。
- ・塗料指定の■は GSI CREOS CORP. MR カラーの番号です。
- ・接着剤や塗料は入っていませんので別にお買い求めください。
- ・部品をランナーから切り離す時は模型用ハサミ等を使い、余分な部分はカッターやヤスリ等で仕上げてください。
- ・組立図のサインマークは下の説明をごらんください。

《注意》

- ・勿於近火處使用膠水或油漆，並打開窗戶保持空氣流通。
- ・■代表 GSI CREOS CORP. 出品 MR.COLOR の顏色編號。不包括膠水及油漆。
- ・自膠架中取出部件時，應用模型專用剪，並用界刀或小鏢除去多餘的膠料。
- ・各圖型的含意可參考本欄以下的說明。

ZUR BEACHTUNG

- ・Kleber und Farbe nicht nahe von offenem Feuer verwenden und das Fenster von Zeit zu Zeit zur Belüftung öffnen.
- ・Der ■ der Farbkennzeichnung bedeutet die Farbnummer von GSI CREOS CORP. MR. COLOR. Kleber und Farbe sind nicht enthalten.
- ・Zum Abschneiden der Teile vom Verbundstück eine Modellierschere verwenden und die überstehenden Plastikteile mit einem Messer oder einer Feile beseitigen.
- ・Die Bedeutung der Symbols finden Sie unten in dieser Spalte.

CAUTION

- ・When you use glue or paint, do not use near a naked flame, and use in a well-ventilated room.
- ・Symbols such as ■ refer to the color number of GSI CREOS CORPS. MR. COLOR. Glue and paint are not included.
- ・When you take parts off the runner frame, use modeling scissors and trim excess plastic with a cutter or a file.
- ・See below for the meaning of symbols.

ATTENTION

- ・Ne pas utiliser de colle ou de peinture a proximite d'une flamme nue, et aerier la piece de temps en temps.
- ・Le numéro ■ pour l'indication de couleurs correspond au numéro de GSI CREOS CORP. MR. COLOR. La colle et la peinture ne sont pas comprises.
- ・Pour retirer les pièces hors du cadre, utiliser des ciseaux spéciaux pour maquette le plastique en excès avec un cutter ou une lime.
- ・Voir la fin de cette colonne pour la signification des symboles

ATTENZIONE

- ・Non usare colla e vernice vicino a fiamme esposte, e aprire le finestre di tanto in tanto per cambiare l'aria.
- ・■ delle indicazioni di colore si riferisce al numero di colore di GSI CREOS CORP. MR. COLOR. Colla e vernice non sono incluse.
- ・Quando si staccano parti del carrello, usare forbici da modellismo e eliminare la plastica in eccesso con un coltello o una lima.
- ・Vedere in fondo a questa colonna per il significato dei simboli.

x2
2つつくってください
MAKE 2PCS
2 TEILE FERTIGEN
EFFEKTUELL 2 PIECES
FAIRE DUE PIZZI
TEE 2 KPL
GOR 2 ST
製作二組

切り取ってください
REMOVE
ENTFERNEN
RETRIEVE
SEPARARE
POISTA
AVLAGSNA
切去

接着しないでください
DO NOT CEMENT
NICHT KLEBEN
NE PAS COLLER
NON INCOLLARE
ELIJIMAA
LIMMAJ
不用粘合

テカールを貼ってください
APPLY DECAL
HIER ABZIEHBILD
APPLIQUEZ DECALCOMANIE
APPLIQUEZ DECALCOMANIE
ASETA SIIRTOKUVA
APPLICERA DECALEEN
貼上水貼紙

穴をうめてください
FILL HOLE
SCHLIESSEN
BOUCHER LE TROU
FORD PIENO
TAYTA REIKA
FYLL HÅLET
挖孔填平

接着剤が乾くまで 2-3 分待ちます。
PLEASE WAIT FOR A FEW MINUTES UNTIL DRY
ENIGE MINUTEN WARTEN BE VOER KLEBSTOFF GETROKKEN IS
AFWETTEN ALZUM MINUTEN IN DIE ZOLA DIE AUSTROH
VEUILLEZ PATIENTER QUELQUES SECONDES SECHAGE
YÄTTÄ VÄRKÄÄN MYNTÄ VÄNEKÄÄN
稍候數分鐘 直至接著劑乾固

注意してください
BE CAREFUL
HIER VORSICHT
FAIRE ATTENTION
USARE ATTENZIONE
VAROIVASTI
FORIKTIGT
小心留意

穴をめてください
OPEN HOLE
ÖFFNEN
FAIRE UN TROU
FORO APERTO
AVAA REIKÄ
OPPIÄ HALET
鑽孔

接着してください
CEMENT TOGETHER
ZUSAMMENKLEBEN
COLLER ENSEMBLE
INCOLLARE INSIEME
LIMMAA YHTEEN
LIMMAA HOP
用膠粘合

折り曲げてください
BEND
BITTE BIEGEN
PLIER S'IL VOUS PLAIT
PIEGARE
TÄTTÄ
BOCCA
屈曲

どちらかを選んでください
OPTIONAL
NACH BELIEBEN
FACULTATIVO
FACOLTATIVO
VALINNANVARAINEN
VALIBAR
可以選擇採用

瞬間接着剤 (金屬用)
INSTANT GLUE FOR METAL
METALLKLEBER
COLLA A METALLO INSTANTANEA
COLLA INSTANTANEA PER METALLU
PIKALIMAA METALLIOSIA VÄRTEN
SNABBUM FOR METALLDELAR
金屬用速乾膠

H 1 GSI CREOS CORP. AQUEOUS HOBBY COLOUR 1 GSI CREOS CORP. MR. COLOUR
MODEL MASTER COLOR

H 1 1	ホワイト	1745	WHITE	WEISS	BLANC	BIANCO	白色
H 6 8	シルバー	1546	SILVER	SILBER	ARGENT	ARGENTO	銀色
H 10 10	カッパー	1551	COPPER	KUPFER	CUIVRE	RAME	銅色
H 12 33	つや消しブラック	1749	FLAT BLACK	MATTSCHWARZ	NOIR MAT	NERO OPACO	啞黑色
H 18 28	黒鉄色	1415	STEEL	STAHL	ACIER	ACCIAIO	黒銀色
H 44 51	はだ色	1516	FLESH	FLEISCHFARBE	CHAIR	COLOR CARNE	肌肉色
H 37 43	ウッドブラウン	1735	WOOD BROWN	HOLZBRAUN	BRUN BOIS	MARRONE LEGNO	木棕色
H 47 41	オリーブブラウン	1533	RED BROWN	ROT BRAUN	MARRON ROUGE	MARRONE ROSSICCIO	紅褐色, 啡紅色
H 48 52	オリブグレー(フィールドグレー(2))	1723	FIELD GRAY(2)	FELDGRAU(2)	GRIS DES TROUPES ALLEMANDES(2)	VERDE CAMPO	田灰色(2)
H 62 56	明灰白色	1730	IJA GRAY	IJA GRAU	GRIS IJN	GRIGIO IJA	IJA 浅灰色
H 66 19	RLM サゾディブラウン79	1706	RLM SANDY BROWN 79	RLM SAND GELB 79	RLM BRUN SABLE 79	SABBIA RLM 79	RLM 砂褐色79
H 71 21	ミドルストーン	1742	MIDDLE STONE	STEINGRAU, MITTEL	PIERRE MOYEN	NOCCILO MEDIO	中石色
H 76 61	焼鉄色	1406	BURNT IRON	GEBR, EISEN	FER BRULÉ	FERRO BRUCIATO	燒鐵色
H 80 54	カーキグリーン	1710	KHAKI GREEN	KHAKIGRÜN	VERT KHAKI	VERDE KAKI	砵磯綠色
H 303 303	グリーン FS34102	1712	GREEN	GRÜN	VERT	VERDE	綠色

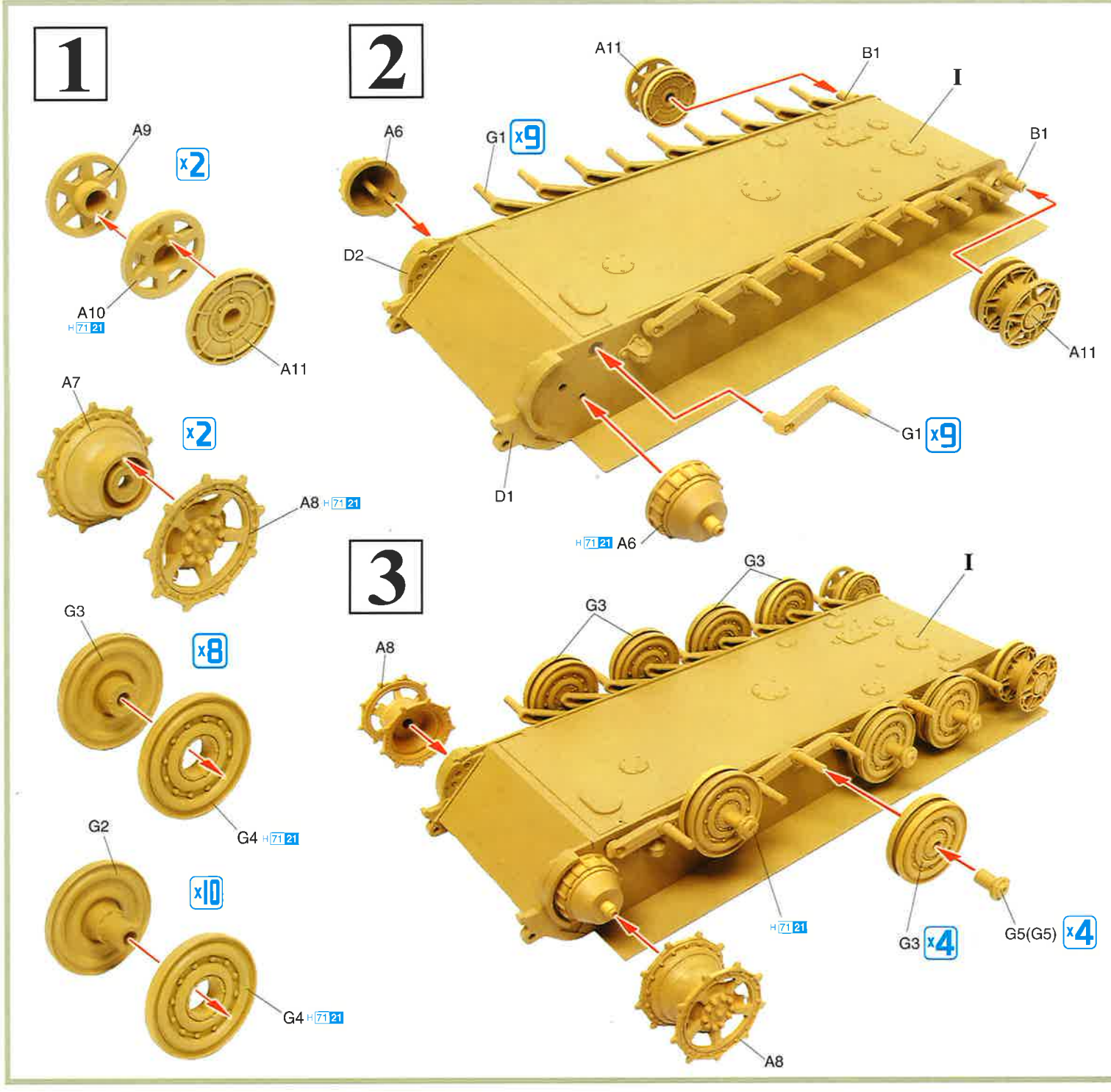

4

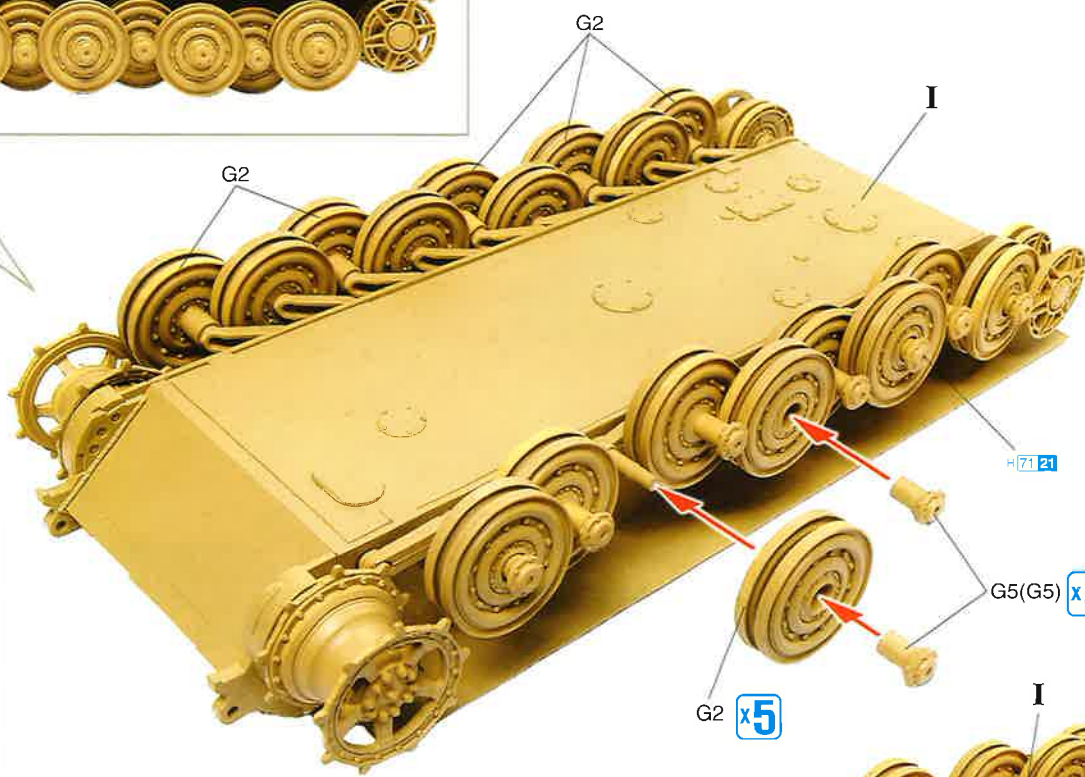

5

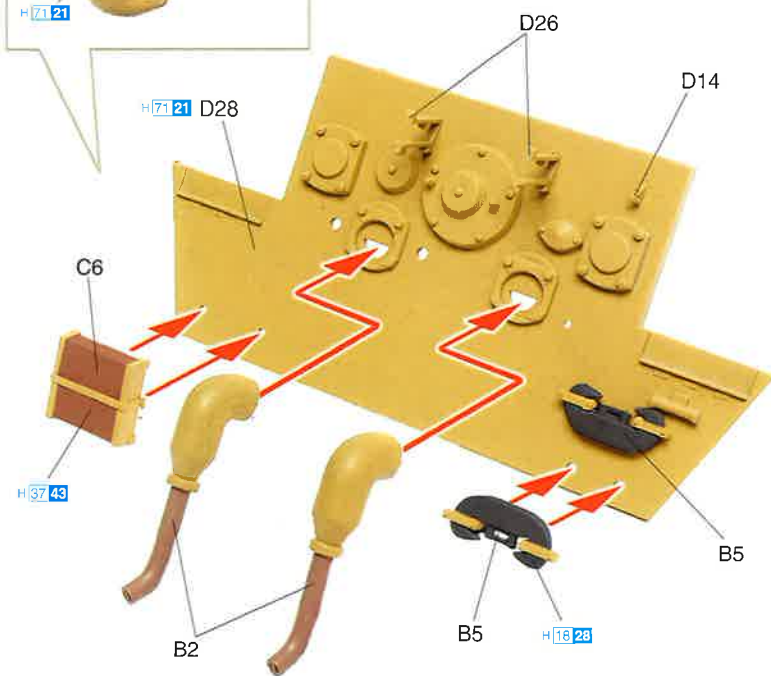
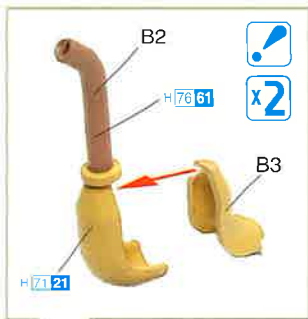

6

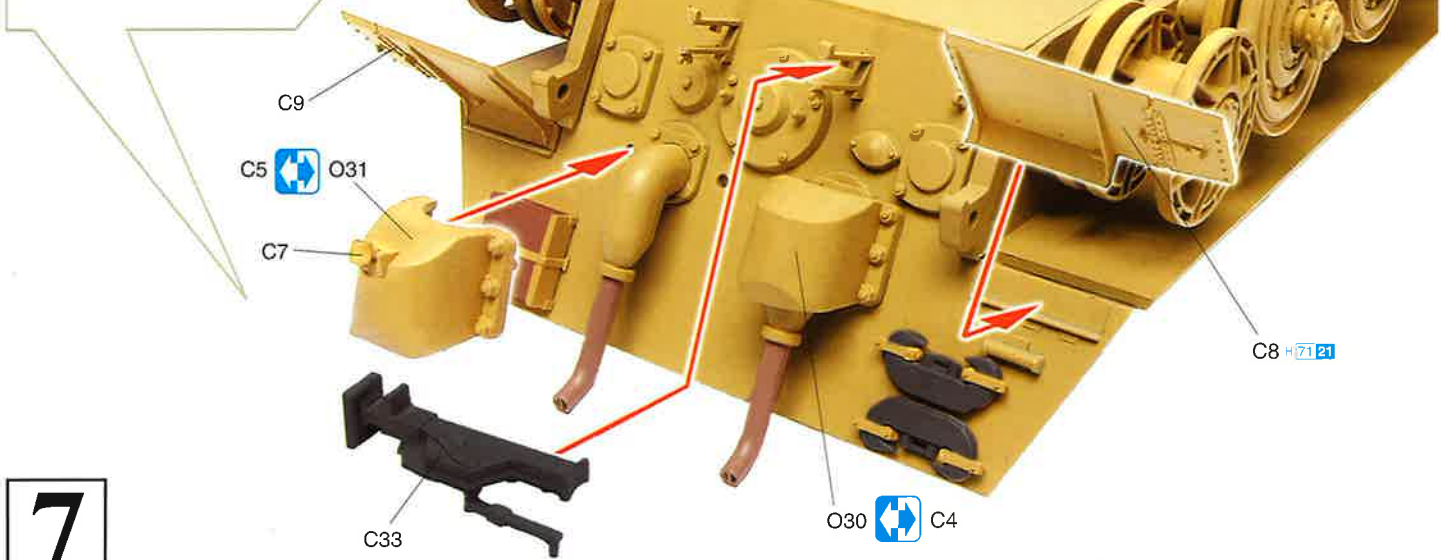
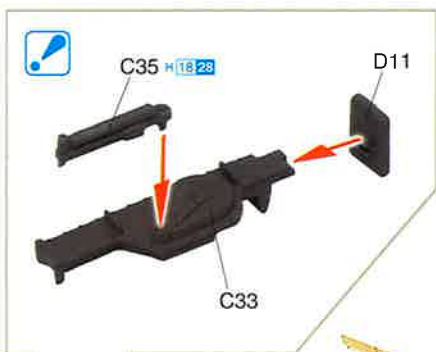

7

8

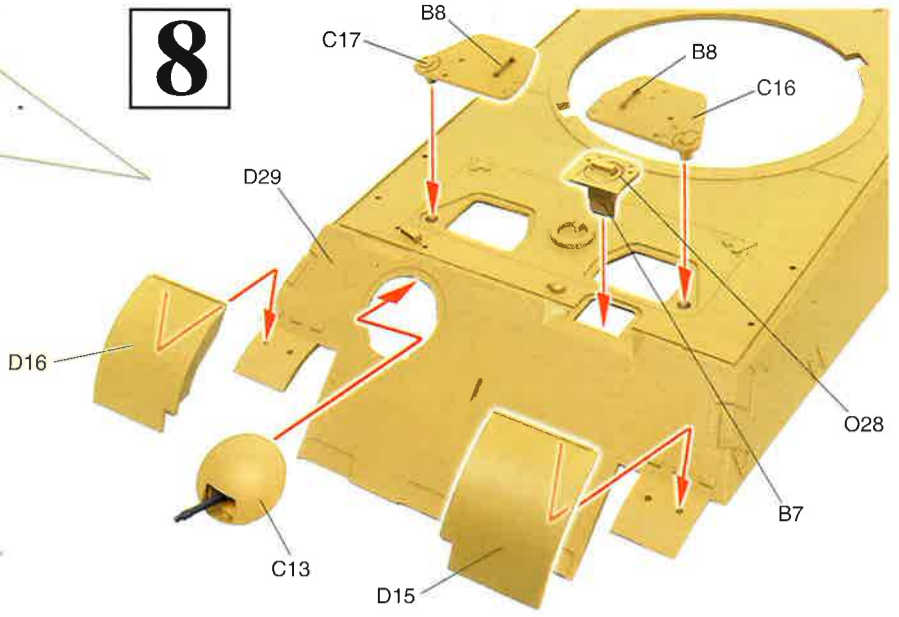
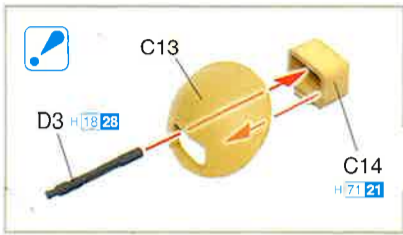
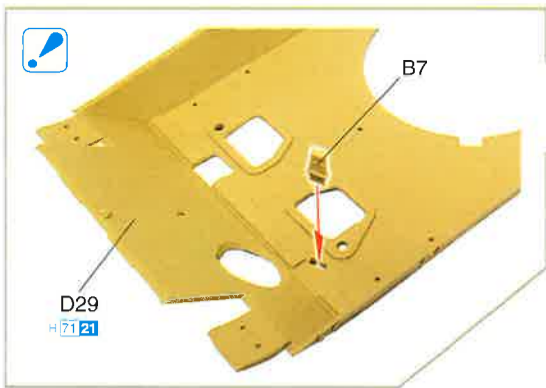

9

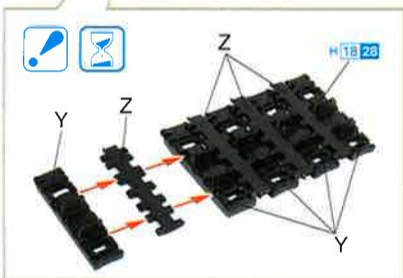

10

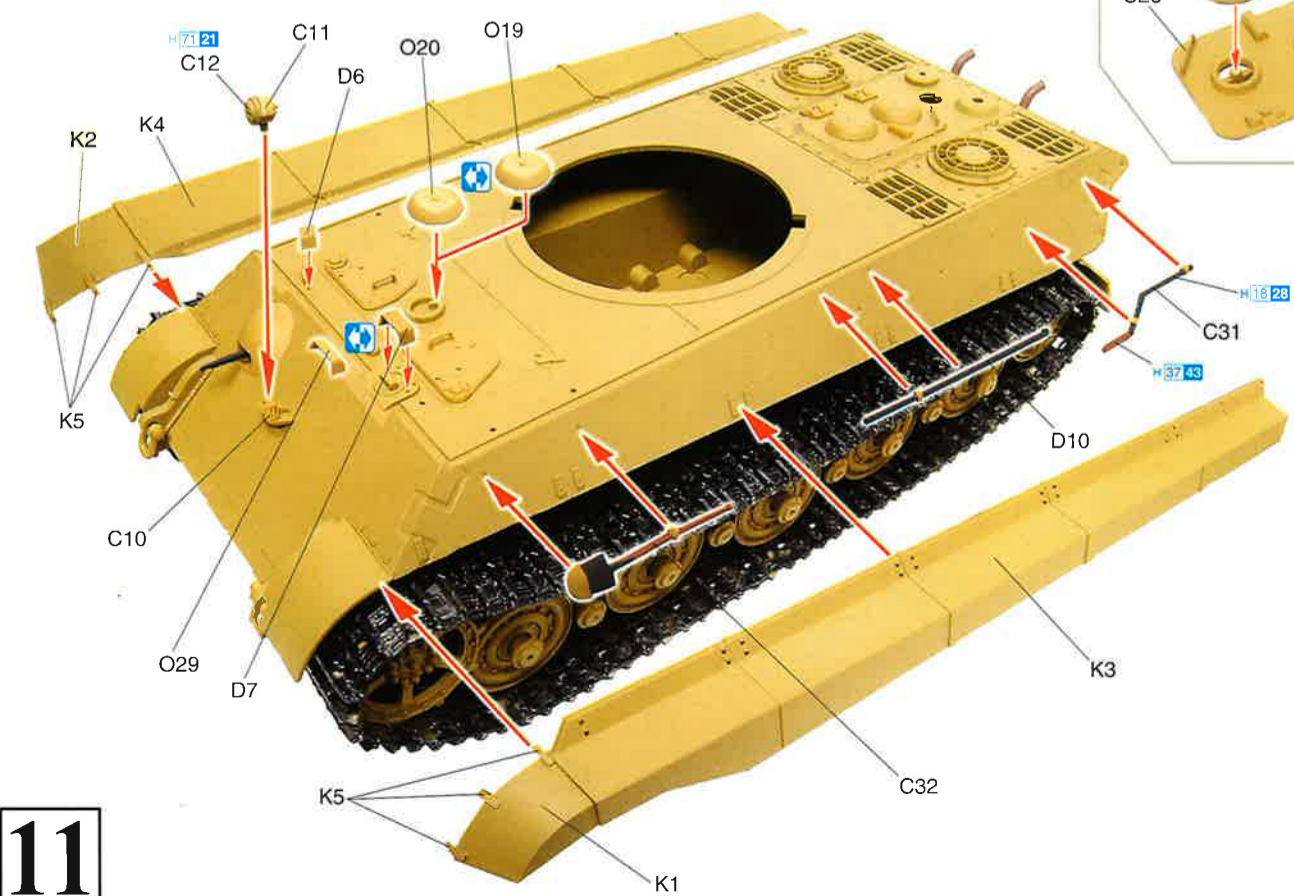
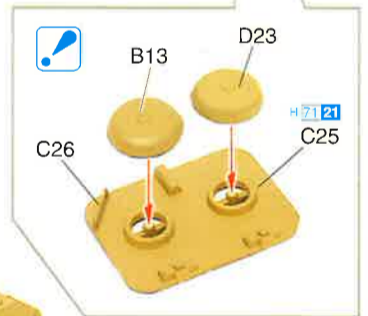
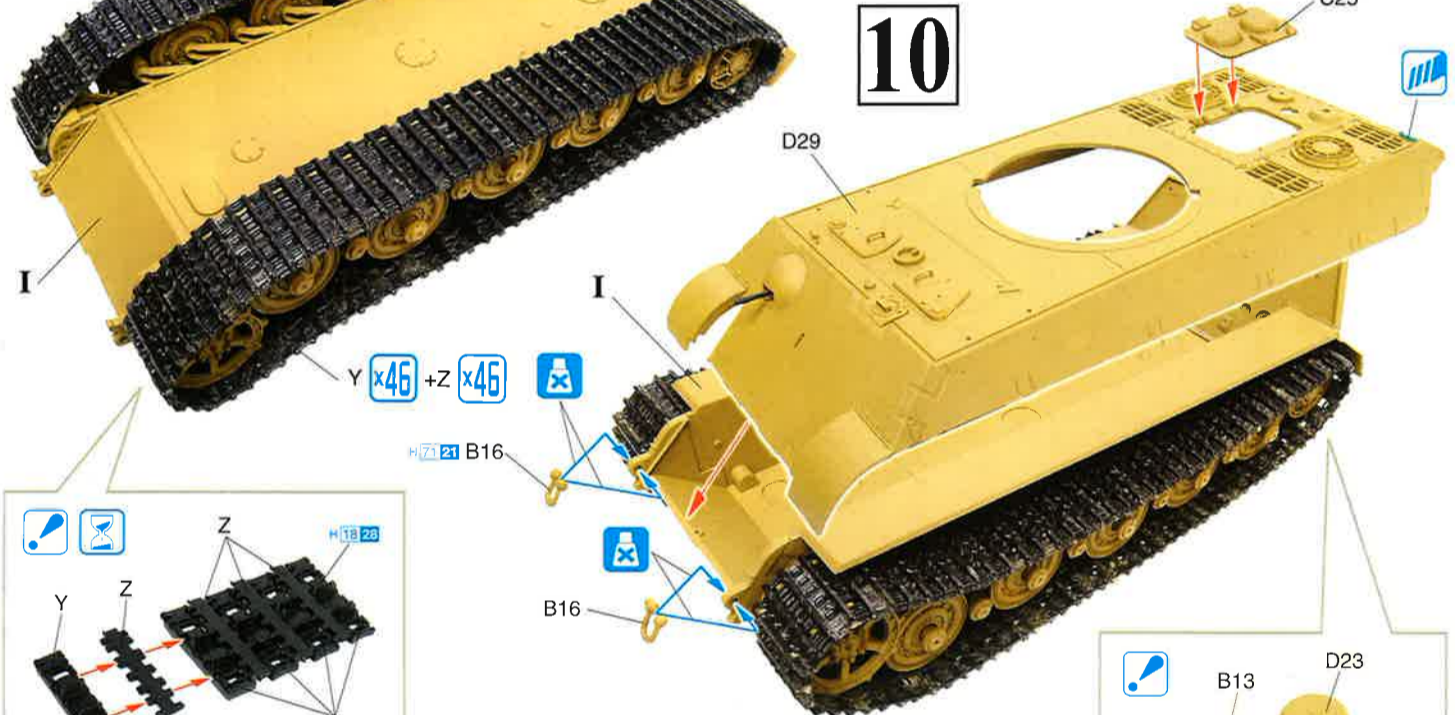

11

12

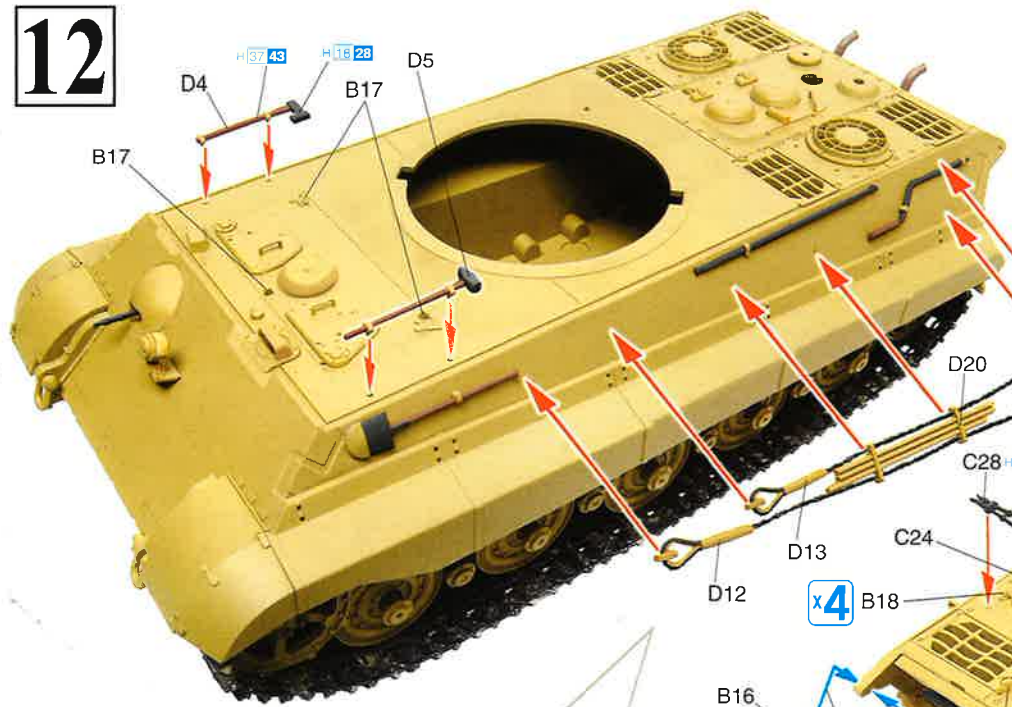

13

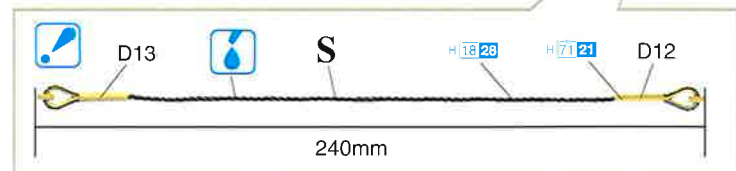
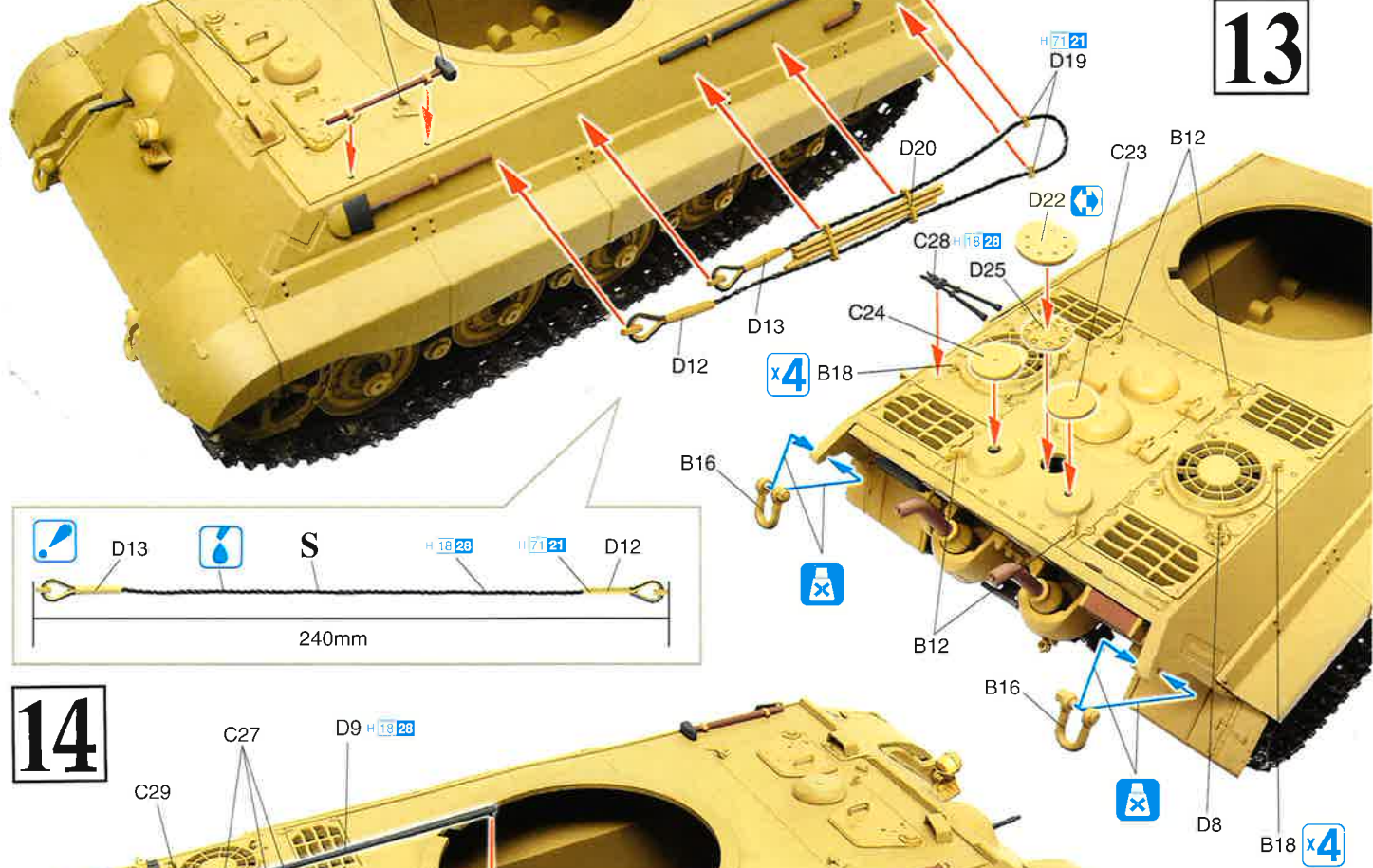

14

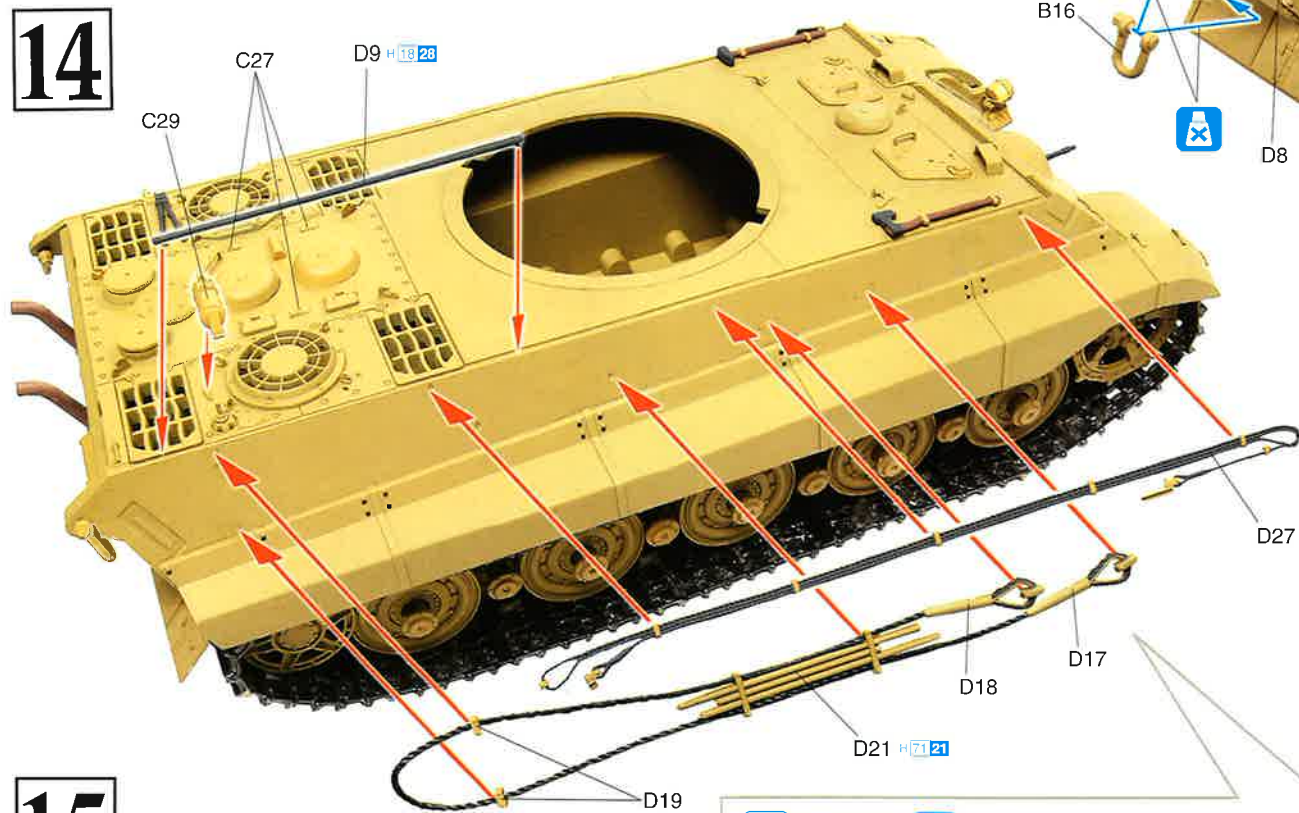

15

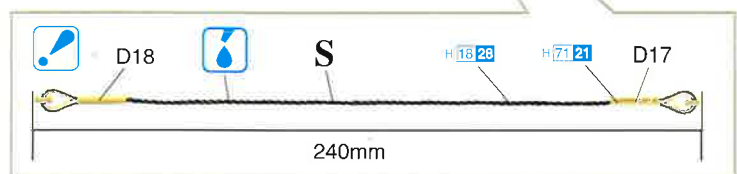
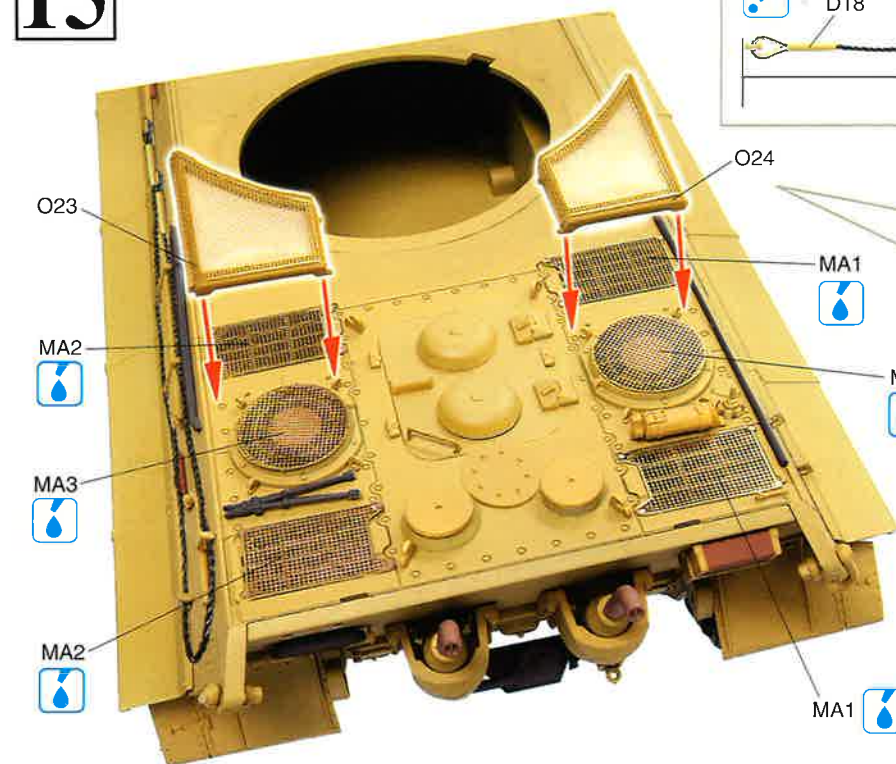

16

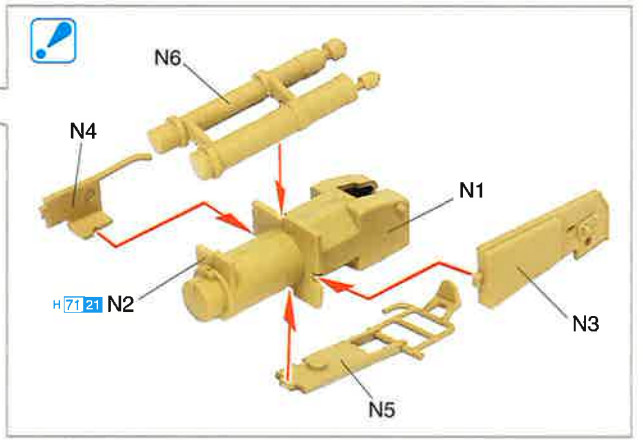
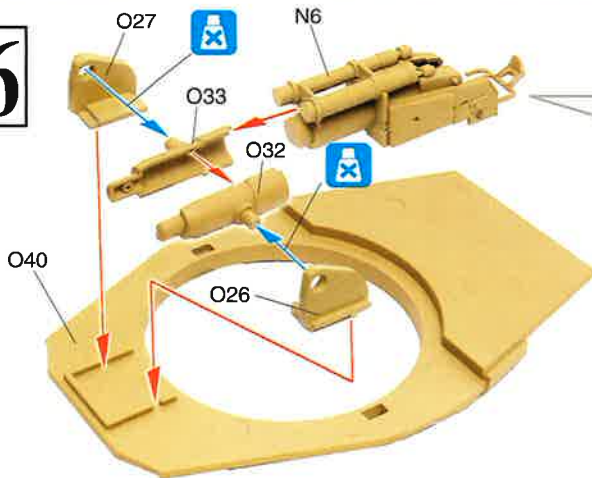

17

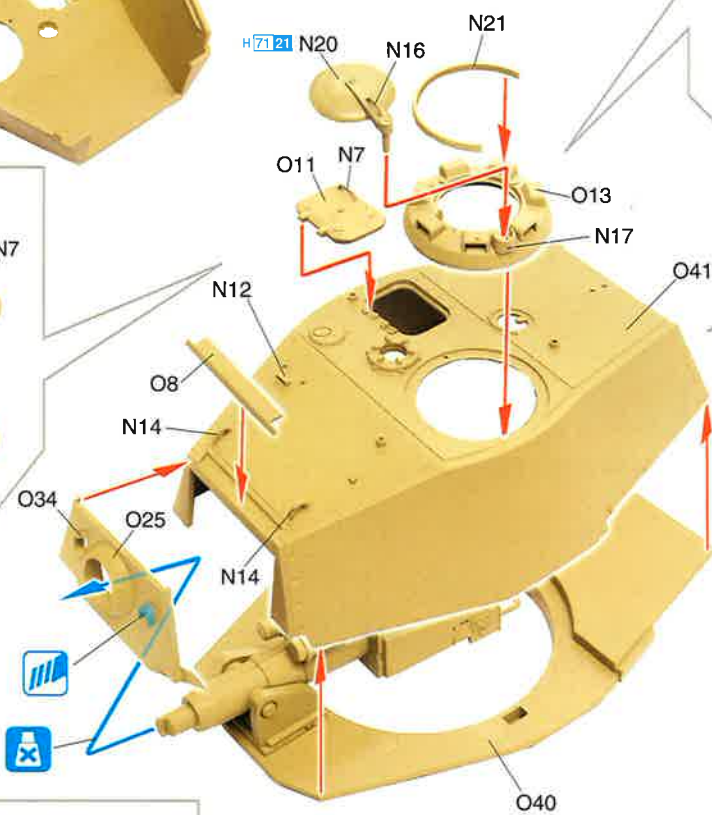
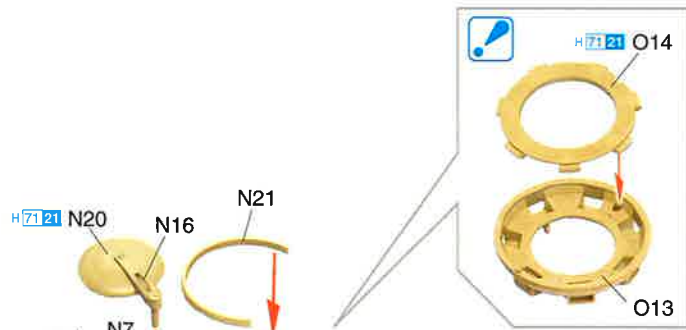

18

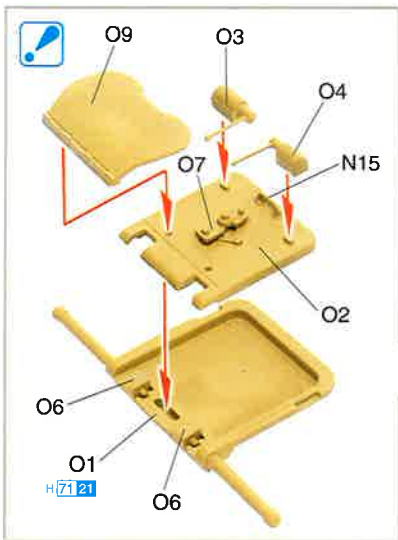

19

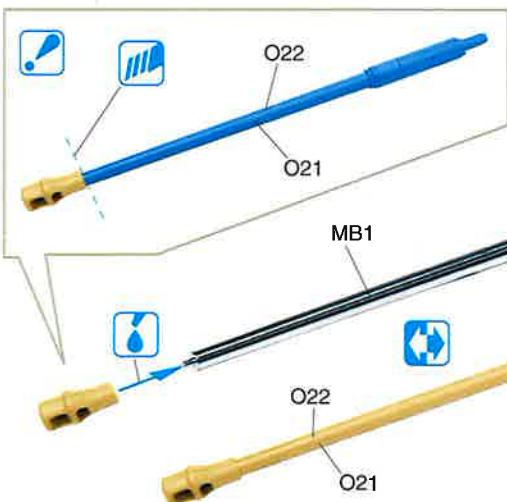
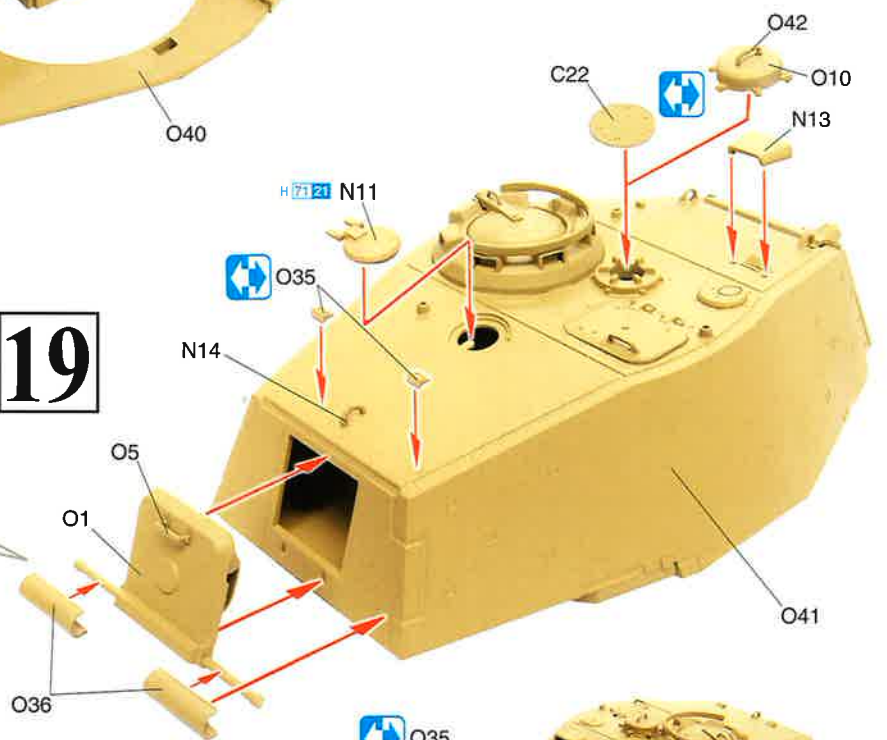

20

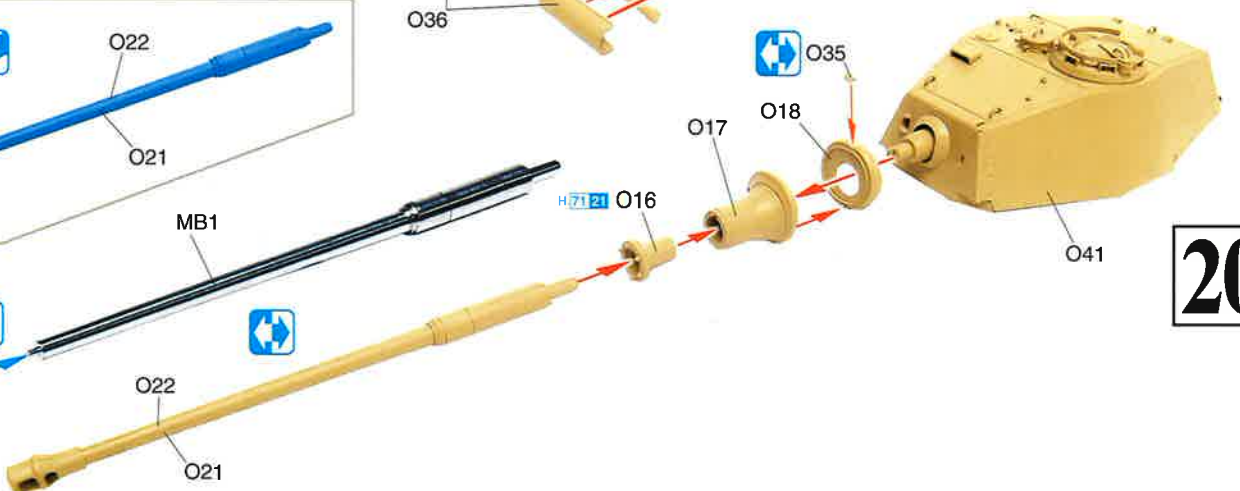



Painting & Markings

マーキング及び塗装図 Markierungen und Bemalung Decoration et Peinture Marchio & Pittura 標貼及着色指示

"222", 2/sPzAbt 501, Ardennes 1944

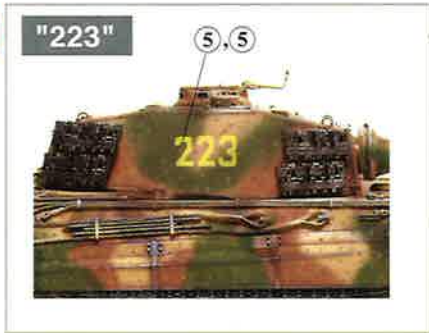

1/sPzAbt 501, Ardennes 1944



2/sPzAbt 501, Ardennes 1944



3/sPzAbt 501, Ardennes 1944



sPzAbt 501



1.Kompanie



2.Kompanie



3.Kompanie

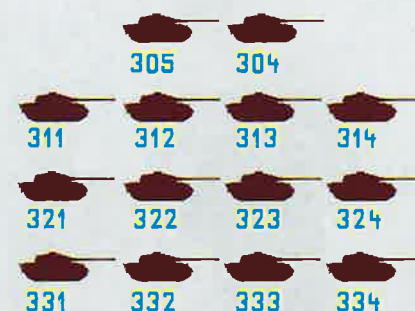

Dragon Europe: c/o Hobby Pro Marketing Ges. m.b.H.
Am Leonhardbach 7, A-8010 GRAZ, AUSTRIA



DRAGON

Copyright © 2005
6254-01

■デカールの貼り方

- ①デカールを貼る場所を綺麗に拭き、ぬらした布できれいにふきとってください。
- ②貼りたいデカールを台紙ごとハサミで切りとり、1枚づつ水またはぬるま湯に台紙を下にして20秒くらい浮かべます。
- ③水から出したらタオルの上ののせ、指先でデカールが動くか確かめた後、貼る位置に指先で台紙をずらします。
- ④指先に少し水をつけて正確な位置にデカールを動かした後、やわらかく、よく水を吸った布でデカールを押さえて内側の水分や気泡を押し出します。
- ⑤デカールが完全に乾いたら少し水をつけ布で、デカールのまわりのノリをふきとります。

■Modo esatto per applicare le decalcomanie

- ① Pulire la superficie del modello con un panno umido.
- ② Ritagliare ciascun disegno dal foglio decalcomanie e immergerli in acqua calda per 20 secondi.
- ③ Controllare col polpastrello se il disegno è allentato sulla base di carta. In questo caso, applicarlo nella esatta posizione sul modello facendolo scivolare dalla base di carta.
- ④ Spostare il disegno nella esatta posizione mediante il polpastrello umido, quindi togliere l'acqua in eccesso e le bolle d'aria sotto la decalcomania mediante un panno soffice di cotone.
- ⑤ Quando la decalcomanie sono asciutte, togliere con un panno umido l'eccesso di colla intorno alla decalcomania stessa.

■Correct Method for Applying Decals

- ① Clean the model surface with a wet cloth.
- ② Cut out each decal design from the decal sheet, and dip it in warm water for 20 seconds.
- ③ Use a fingertip to check if the decal is loose from the backing paper. If so, place it in the proper position on the model, and slide it off the backing paper onto the model.
- ④ Move the design to the exact position with a wet fingertip, and squeeze out any excess water or air bubbles under the decal with a soft cotton cloth.
- ⑤ When the decals are dry, use a wet cloth to gently wipe away any residue left around them.

■Comment appliquer les décalcomanies correctement

- ① Nettoyer la surface du modèle avec un chiffon humide.
- ② Découper chaque décalcomanie de sa feuille de papier et la plonger dans l'eau tiède pendant vingt secondes.
- ③ Vérifier avec le bout du doigt si le dessin se détache de son papier-support. Si oui, le positionner à l'endroit choisi sur le modèle et retirer doucement le papier-support.
- ④ Positionner la décalcomanie correctement avec un doigt humide et éponger tout restant d'eau et toutes bulles d'air sous la décalcomanie avec un chiffon doux.
- ⑤ Quand les décalcomanies sont sèche, détacher le colle autour des décalcomanies avec un chiffon humide.

■Das Korrekte Aufbringen der Abziehbilder

- ① Oberfläche des Modells mit feuchtem Tuch reinigen.
- ② Jedes Motiv einzeln aus dem Bogen heraus schneiden und 20 Sekunden in warmes Wasser tauchen.
- ③ Mit dem Finger prüfen, ob sich das Motiv vom Trägerpapier gelöst hat. Wenn ja, so schieben Sie es vom Papier weg und seine genaue Position auf dem Modell.
- ④ Korrigieren Sie die exakte Lage mit nasser Fingerspitze und drücken Sie Wasserbläschen unter dem Abziehbild mit einem weichen Baumwolltuch weg.
- ⑤ Entfernen Sie beim Antrocknen der Abziehbilder die Klebmittelränder mit einem feuchten Tuch.

■貼上水印標貼的正確方法：

- ① 用濕布抹乾淨模型表面。
- ② 按照各標貼的形狀從標貼紙上切出，達到溫水之中約 20 秒。
- ③ 用指尖試行觸摸以確定標貼是否已脫離底紙，如果確實，則把標貼從底紙放到模型表面的適當位置上，小心地將底紙移去，把標貼留在模型表面。
- ④ 以濕水的指尖把標貼移到正確的位置上，再用柔軟的綿質布料把標貼輕壓，以擠出標貼底下的氣泡和水分。
- ⑤ 標貼乾後，用濕布輕拭標貼及其附近的模型表面，以洗去可能殘留在標貼附近的多餘膠水，確保效果完美。