



BAHARI PONTIAC STOCK CAR

KIT 2932

1/24 SCALE MASSTAB 1/24 ESCALA 1/24
SCHAAL 1/24 1/24 ECHELLE SKALA 1/24 SCALA 1/24

MONOGRAM MODELS, INC. Morton Grove, Ill. Copyright © 1990. All rights reserved. Made in U.S.A. 2932 M 0200

READ THIS BEFORE YOU BEGIN

- Study the assembly drawings.
- Each plastic part is identified by a number.
- In the assembly drawings, some parts will be marked by a star (*) to indicate plated plastic.
- Scrape plating from areas to be cemented.
- Check the fit of each piece before cementing in place.
- Do not use too much cement to join parts.
- Use only cement for polystyrene plastic.
- Model may be painted to match photos on box.
- Allow paint to dry thoroughly before handling parts.
- Scrape paint from areas to be cemented.
- For better paint and decal adhesion, wash the plastic parts in a mild detergent solution. Rinse and let air dry.

ALLGEMEINE HINWEISE

- Die Anordnung der Bauteile ist aus den Zeichnungen der Anleitung ersichtlich.
- Jedes Plastikteil ist durch eine Nummer gekennzeichnet.
- Beschichtete Teile sind in den Zeichnungen mit einem Stern (*) bezeichnet.
- Die Beschichtung muss von allen Klebestellen vorher entfernt werden.
- Die Teile vor dem Verkleben ungeleimt zusammenhalten, um ihren Passzitz zu prüfen.
- Klebstoff nicht zu dick auftragen.
- Nur Modellbaukleber für Polystyrol verwenden.
- Man kann das Modell nach den Fotos auf der schachtel streichen.
- Bemalte Teile vor der Weiterverwendung gut trocknen lassen.
- Die Farbe muss von allen späteren Klebestellen abgeschabt werden.
- Damit die Farbe und die Abziehbilder besser kleben, sind die Plastikteile in einer milden Seifenlauge zu waschen. Dann abspülen und an der Luft trocknen lassen.

LEA ESTO ANTES DE EMPEZAR

- Estudie los dibujos de ensamblaje.
- Cada pieza de plástico se identifica por un número.
- En los dibujos de ensamblaje, algunos números de las piezas están marcados con una estrella (*) para indicar plástico laminado.
- Raspe el laminado de las superficies que serán pegadas.

- Verifique que cada pieza encaje bien antes de pegar en posición.
- No use demasiado pegamento para unir las piezas.
- Use únicamente pegamento para plástico de poliestirena.
- El modelo puede pintarse de acuerdo con las fotografías de la caja.
- Permita que se seque la pintura completamente antes de tocar las piezas.
- Raspe la pintura de las superficies que serán pegadas.
- Para una mejor fijación de la pintura y de las calcomanías, lávase las piezas plásticas en una solución de detergente suave. Enjuáguese y déjese secar al aire.

LEES DIT ALVORENS TE BEGINNEN

- Bestudeer de bouwtekening.
- Elk plastic onderdeel is genummerd.
- Nummers met een ster (*) op de bouwtekening geven verchromde plastic onderdelen aan.
- Verwijder het chrom van te lijmen oppervlakken.
- Controleer de passing van elk deel vóór het lijmen.
- Gebruik niet te veel lijm.
- Alén lijm voor polystyreen plastic gebruiken.
- Men kan model verven zoals aangeduid op de doos.
- Laat de verf van de te verwerken delen steeds goed drogen.
- Verwijder de verf van te lijmen oppervlakken.
- Zodat de verf en etiquetten beter zullen plakken, was de plastieke delen in een milde seep oplossing. Spoel en laat in de openlucht opdrogen.

LISEZ CE QUI SUIT AVANT DE COMMENCER LE MONTAGE

- Etudier les schémas d'assemblage.
- Chaque pièce plastique porte un numéro d'identification.
- Sur les schémas d'assemblage, les pièces dont le numéro comporte une astérique (*) sont en plastique chromé.
- Grattez le chromage sur les surfaces à coller.
- Contrôler que chaque pièce soit bien conforme avant de la coller à sa place.
- N'utilisez pas trop de colle pour réunir les pièces.
- Utilisez uniquement une colle spéciale pour polystyrène.
- Le modèle peut être peint conformément aux photos sur la boîte.

- Laissez sécher la peinture complètement, avant de manipuler les pièces.
- Grattez la peinture sur les surfaces devant être collées.
- Pour assurer la meilleure adhésion possible de la peinture et des décalcomanies, lavez les pièces de plastique avec une légère solution savonneuse. Rincez et laissez sécher à l'air.

LAS DET HAR INNAN DU BORJAR BYGGA

- Studera monteringskisserna.
- Alla plastdelar har identifikationsnummer.
- Vissa nummer på monteringsanvisningarna har en stjärna (*) som betyder att delen är plåströcklad.
- Skrapa bort förnäcklingen på de ytor som ska limmas.
- Kolla noga att delarna passar före limningen.
- Stryk inte för mycket lim på delarna.
- Använd endast lim för polystyren-plast.
- Modellerna kan målas enligt foton på kantonngen.
- Låt färgen torra ordentligt före limningen.
- Skrapa bort färgen på de ytor som ska limmas.
- För bättre vidhäftning av färg och dekalmarkering rengör plastdelarna i en mild tvättmedelslösning. Skölj och låt lufttorka.

DA LEGGERE PRIMA DI INIZIARE

- Studia le illustrazioni.
- Ogni pezzo è identificato da un numero.
- Nelle illustrazioni, alcuni numeri di identificazione sono contrassegnati da un asterisco (*) per indicare che sono cromati.
- Asporta la cromature dalle superfici che devono essere incollate.
- Controlla l'incastro di ogni pezzo prima di incollarlo.
- Non usare troppa colla per unire i pezzi.
- Adopera solamente colla per materie plastiche.
- Il modello si può dipingere seguendo le fotografie sulla scatola.
- Aspetta che la vernice sia completamente asciutta prima di maneggiare le parti.
- Asportala la vernice dai punti dove applicherai la colla.
- Per una migliore aderenza di vernice e decalcomanie, lavare le parti in plastica in soluzione detergente non abrasiva. Risciacquare e lasciar asciugare all'aria.

Every effort has been made to create and manufacture a model kit that is the finest available. If a part may be missing, please write to:

Monogram Models, Incorporated
Consumer Service Department
395 North Third Avenue
Des Plaines, Illinois 60016

Be sure to include the kit number, part number, description, and your return address.



REMOVE AND THROW AWAY
ENTFERNEN (ANFALL)
QUITE Y TIRE
VERWILDEREN EN WEGGOEDEN
À RETENIR ET JETER
AVLAGNAS OCH MAKULERAS
RINQUOY ED ELIMINA



OPTIONAL PARTS
BAUTEILE NACH WAHL
PEZAS OPCIONALES
KEUZE ONDERDELEN
PEZES EN OPTIEN
VALFRIA DELAR
PARTI FACOLTATIVE



DECAL (DIP IN WATER)
ABZIEHBLD
DECALCOMANIA (MOJE CON AGUA)
TRANSFERS (IN WATER OPEN)
DECALCOMANIE (A PLONDER DANS LE AU)
DECAL (DOPPAS I VATTEN)
DECALCOMANIA (IMMERGI IN ACQUA)



DO NOT CEMENT
NIGHT KLEBEN
NO USE PEGAMENTO
NET LUMEN
NE PAS COLLER
LIMMAS INTE
NON INCOLLARE



REPEAT SEVERAL TIMES
ARBEITSGANG MEHRMALS WIEDERHOLEN
REPITA VARIAS VECES
EWSJE KEREK MEKHALEN
À REPETER PLUSIEURS FOIS
ARBEITSMOMENT SOM UPPREPAS
RIPETI DIVERSE VOLTE

A	BLACK	SCHWARZ	NEGRO	ZWART	NOIR	SVART	NERO
B	FLAT BLACK	GLANZLOSES SCHWARZ	NEGRO APAGADO	GLANZLOS ZWART	NOIR TERNE	MATTSVART	NERO OPACO
C	YELLOW	GELB	AMARILLO	GEEL	JAUNE	GUL	GIALLO
D	METALLIC	METALLIC	METALLIC	METALLIEK	METALLIC	METALLGLANS	METALLICO
E	SILVER	SILBERN	PLATA	ZILVER	ARGENT	SILVERGLANS	ARGENTO
F	ALUMINUM	ALUMINIUMFARBEN	ALUMINIO	ALUMINIUMKLEURIG	ALUMINIUM	ALUMINIUMFÄRGAD	ALUMINIO
G	WHITE	WEISS	BLANCO	WIT	BLANC	VIT	BIANCO

1

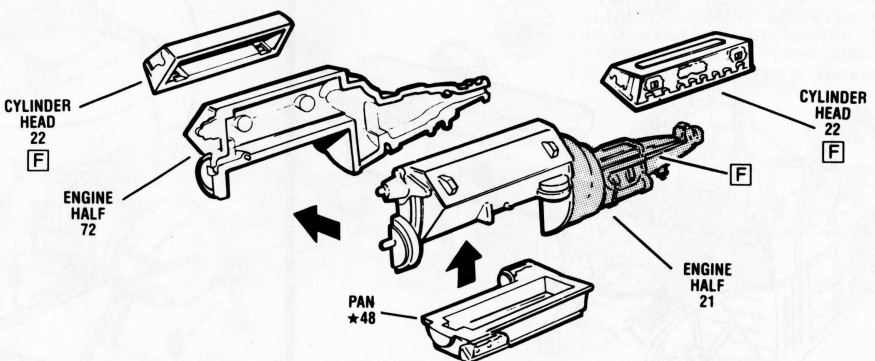

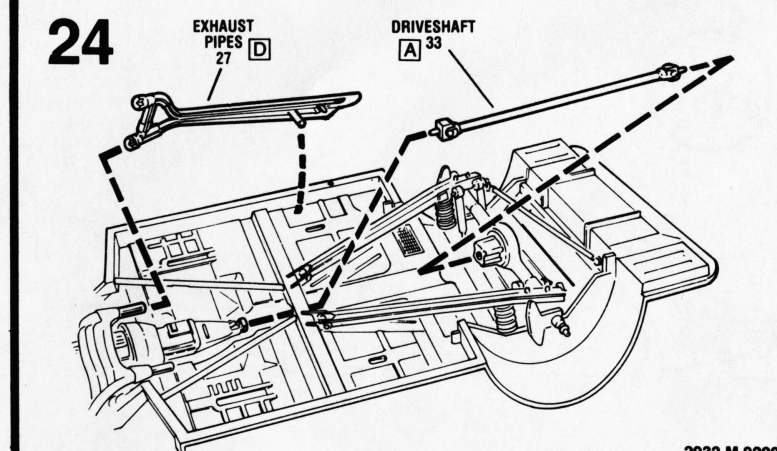
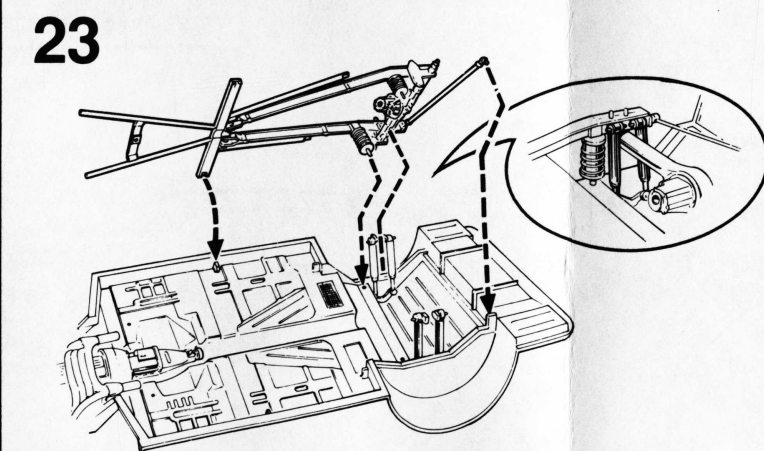
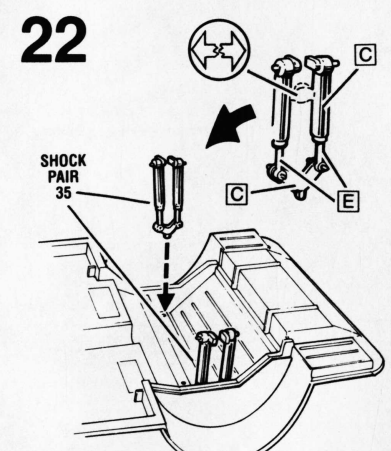
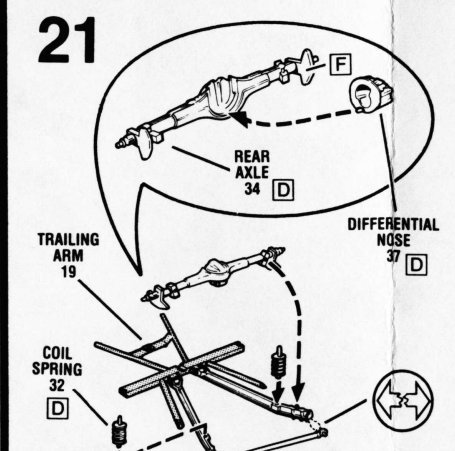
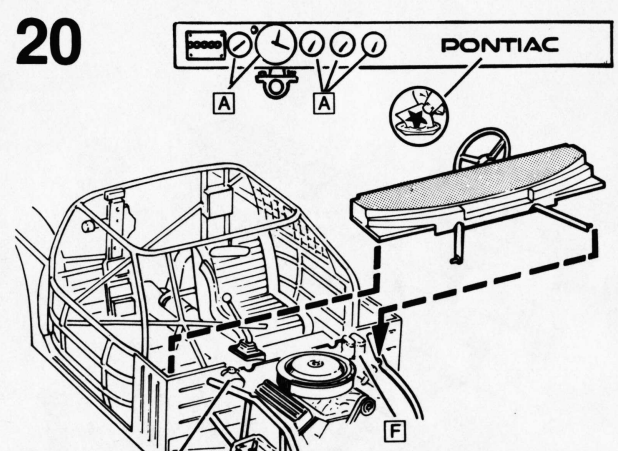
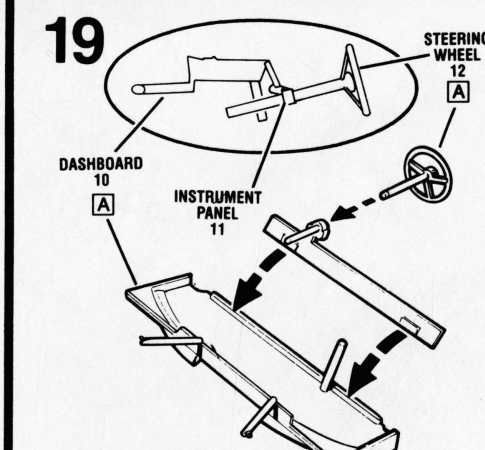
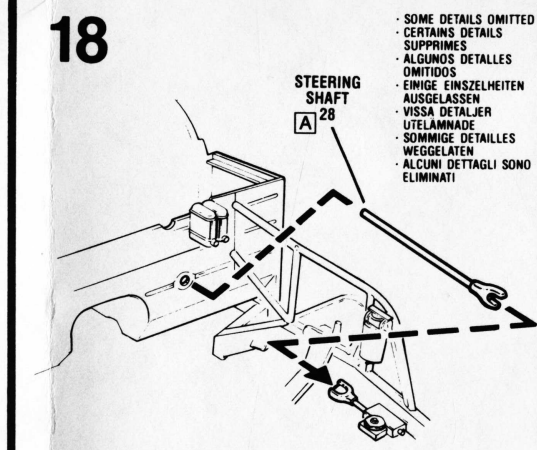
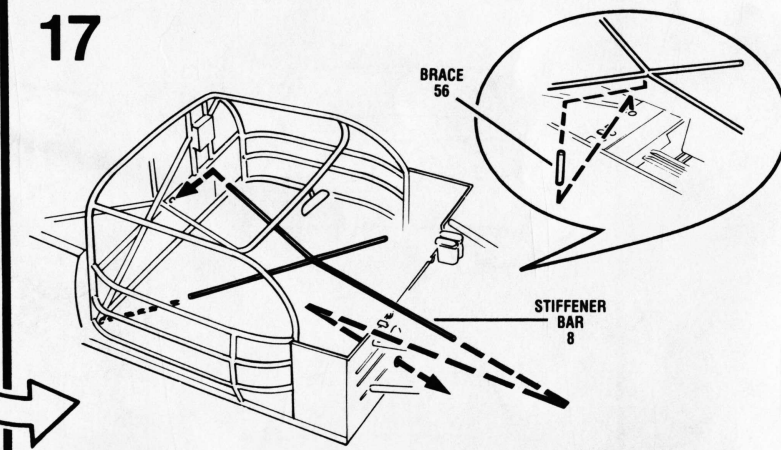
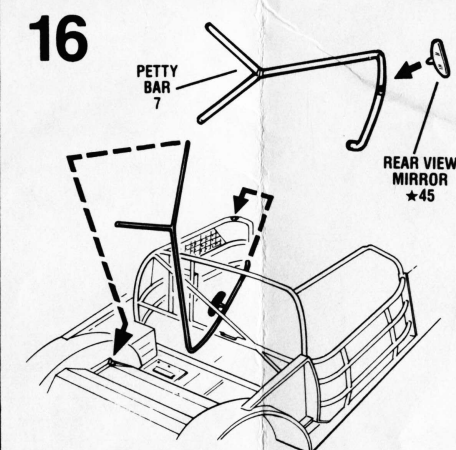
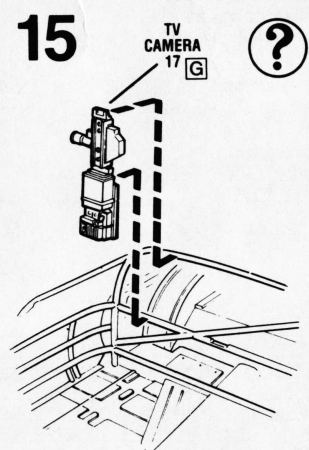
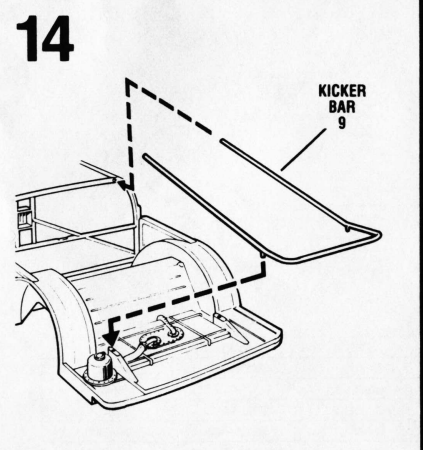
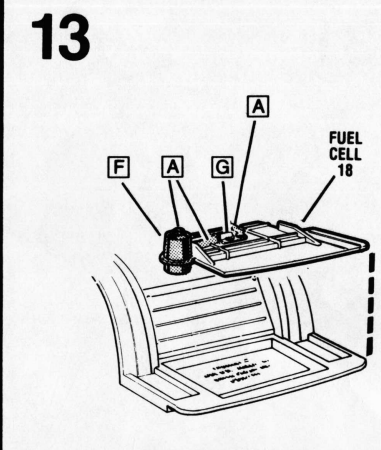
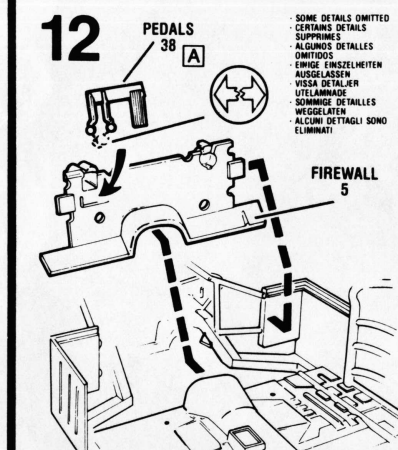
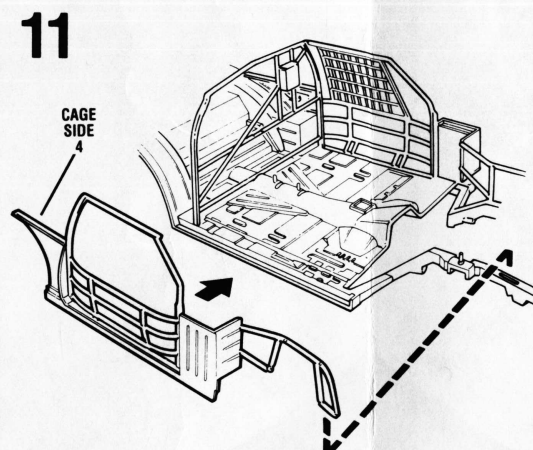
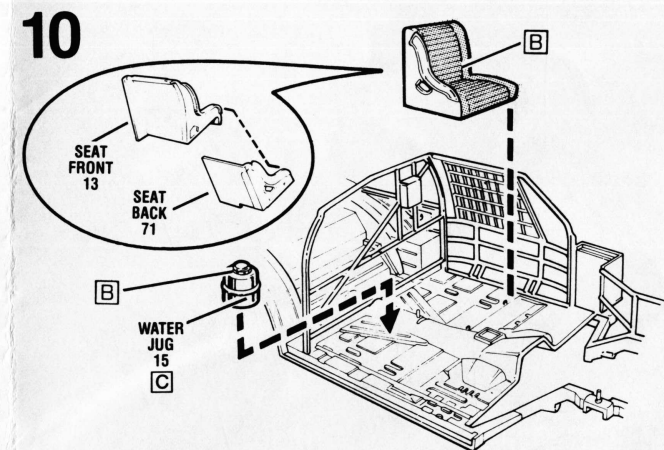
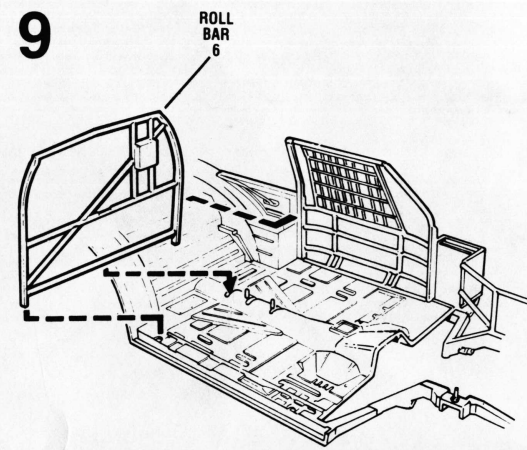
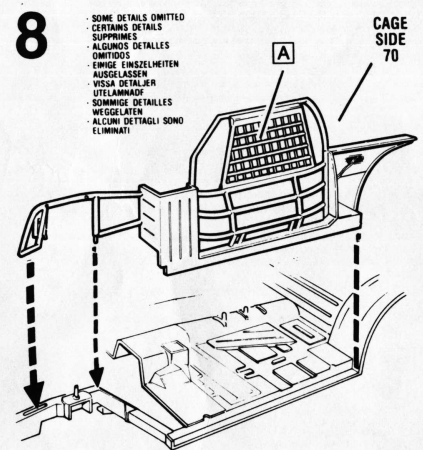
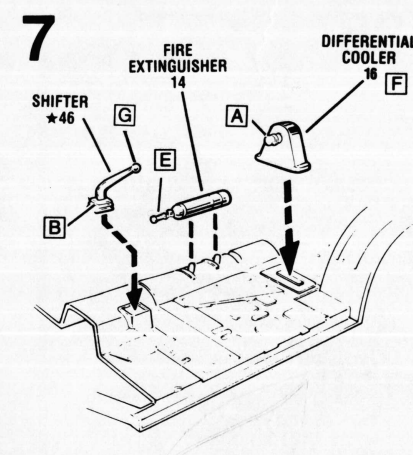
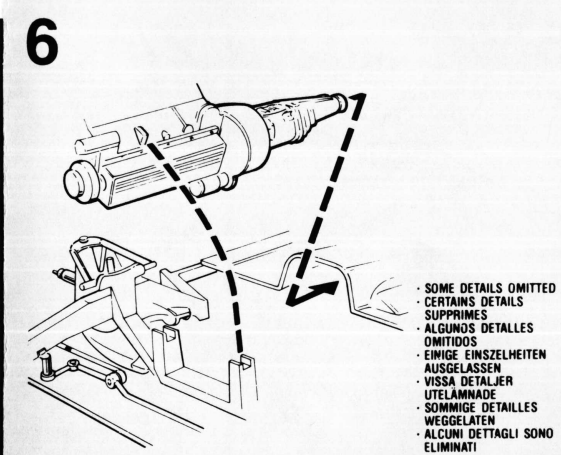
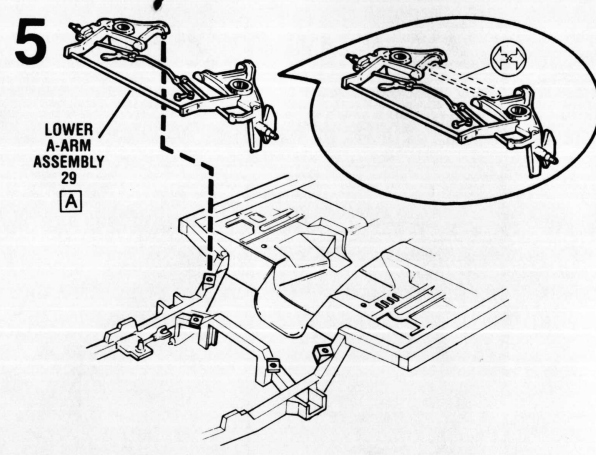
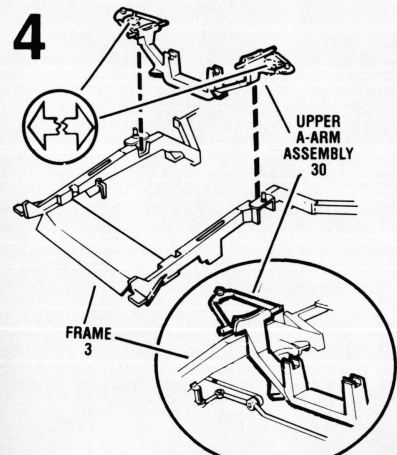
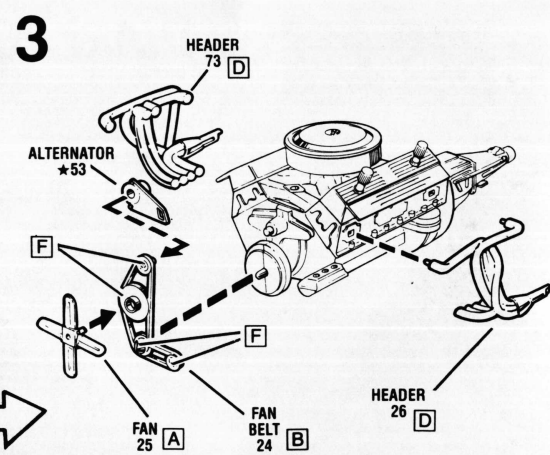
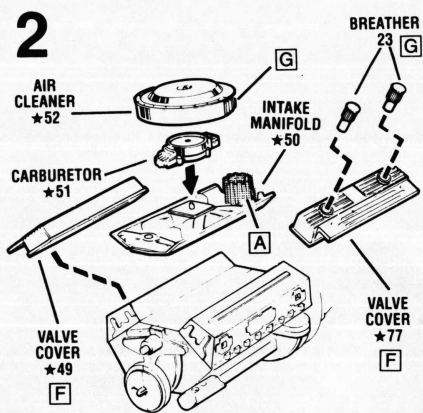

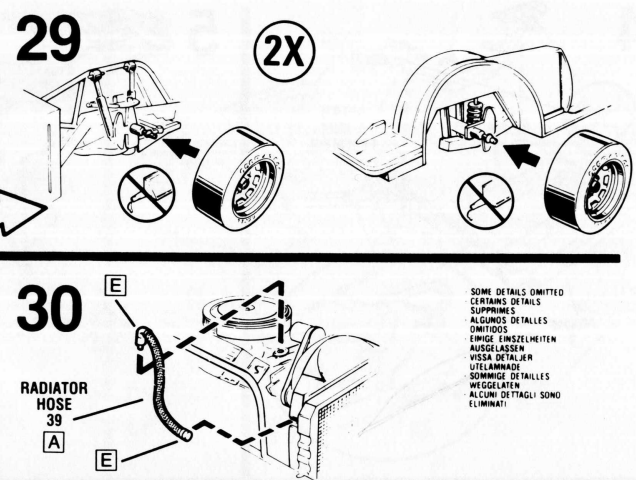
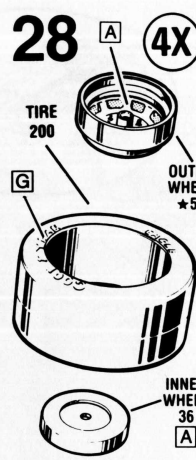
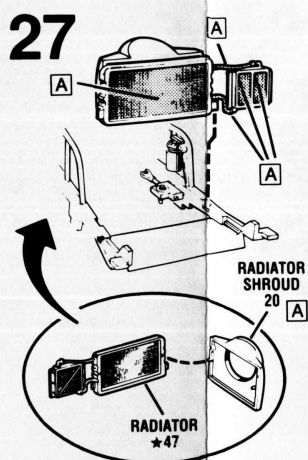
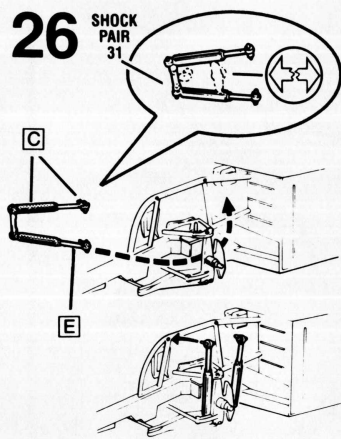
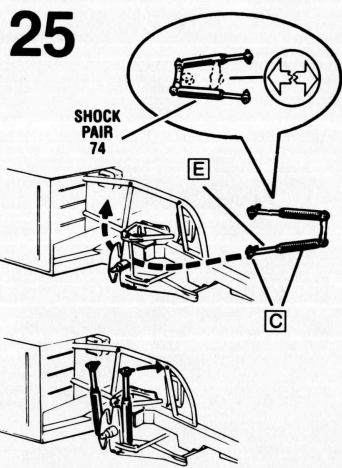

SOME DETAILS OMITTED
CERTAINS DÉTAILS
SUPPRIMÉS
ALCUNOS DETALLES
OMITIDOS
EMIGE EINZELHEITEN
AUSGELASSEN
VISSA DETALJER
UTELÄMNAD
SOMMIGE DETAILLES
WEGGELASSEN
ALCUNI DETAGLI SONO
ELIMINATI

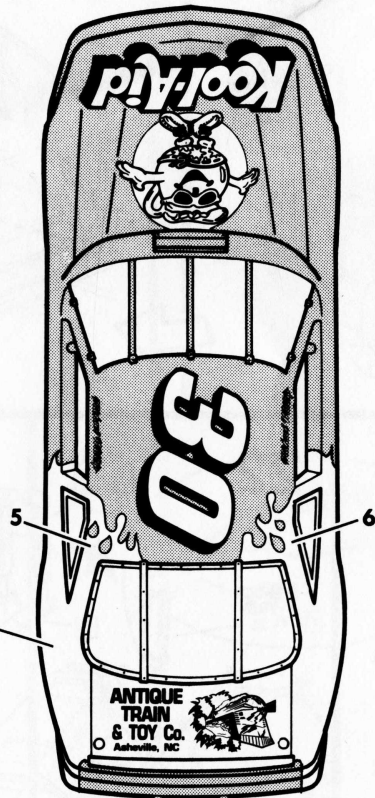
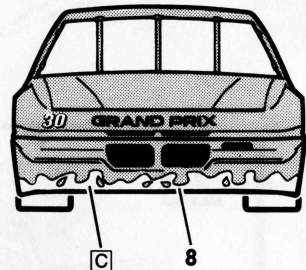
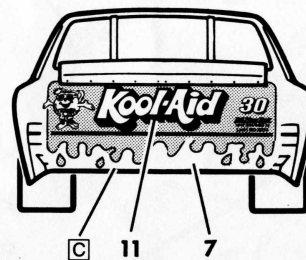
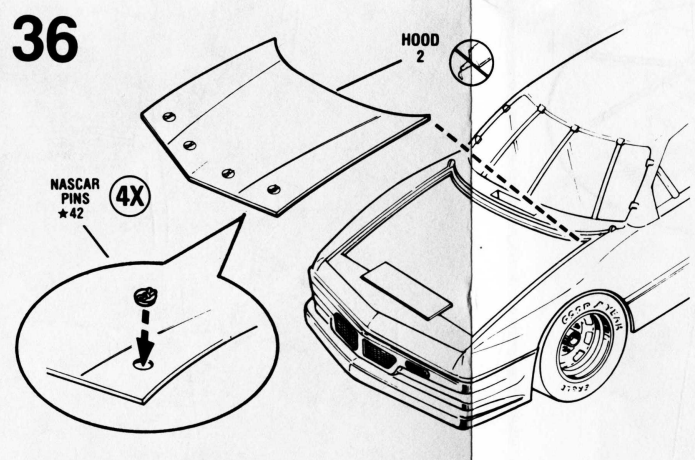
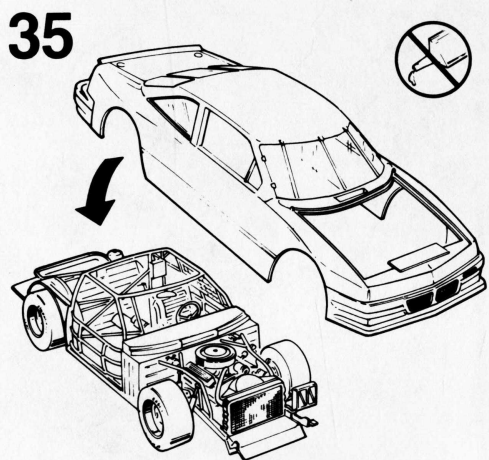
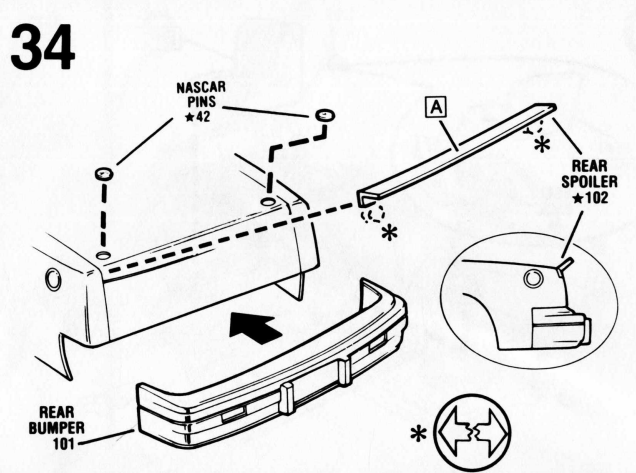
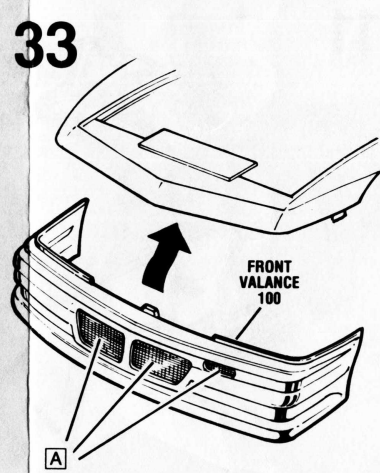
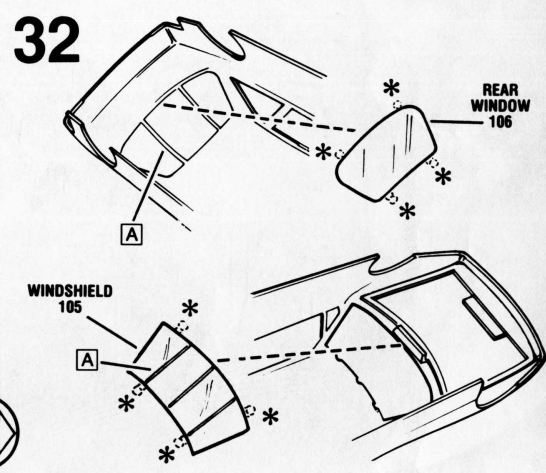
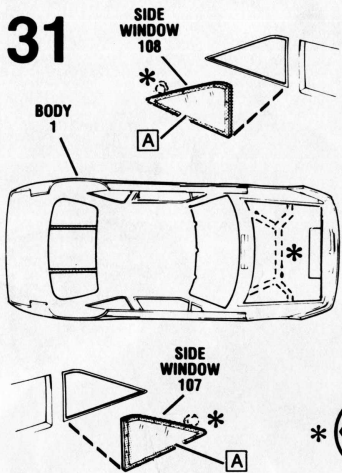

- DISCARD ALL REMAINING PIECES
- ALLE ÜBRIGEN TEILE BESEITIGEN
- DESECHENSE TODAS LAS PIEZAS RESTANTES
- ALLE OVERBLIJVENDE DELEN KUNNEN WEGGEGOOD WORDEN
- SE DEBARASSER DE TOUTES LES PIÉCES RESTANTES
- KASTA BORT ALLA KVARVARANDE BITAR
- SCARTARE TUTTI I PEZZI RIMANENTI

