



AH-64A APACHE

1/72 Scale

Since the Vietnam War showed the value of the helicopter's unique abilities in the field of armed combat, the shape and purpose of rotary-winged aircraft has taken a new direction. As a result of the actions of heavily armed attack helicopters, a new generation of the helicopter has produced some of the most deadly flying machines to darken the sky.

The first designed-to-order offensive helicopter was the Bell HueyCobra, which proved the concept of a true fighting rotary-winged aircraft. From the sleek lines of the HueyCobra have developed the sinister and more heavily-armed attack helicopters such as the Hughes AH-64, Apache. Winner in the 1976 competition for a front-line attack helicopter, capable of operating in all weather, day or night, the Apache is formidable weapon. A rugged aircraft, the Apache has been designed for survivability of its crew. For example, should the AH-64 crash, the M230 30mm Chain Gun would collapse upward between the two cockpits. The flat canopy panels are armored and designed to deflect bullets and reduce sunlight reflections which could pinpoint the location of the helicopter.

The M230 Chain Gun is a 30 mm cannon with but a single barrel aimed by a chain drive. It can fire up to 1,200 rounds per minute, but on the Apache it is usually restricted to 625 rpm. It is normally armed with eight Hellfire missiles under its stub wings. Even Sidewinder missiles can be attached to its wingtips for anti-aircraft defense.

In 1984, the Hughes Helicopter Co. was purchased by McDonnell Douglas and the name changed to McDonnell Douglas Helicopter Co.

ACADEMY
아카데미
MINICRAFT

1649



Cement Parts
Coller
Kleben
Pegar
Incollare
Colar
Kleven



DO NOT cement
Ne pas coller
Nicht kleben
No pegar
Non incollare
Nao colar
Niet kleven



Cut away
Couper
Scheiden
Cortar
Tagliare
Cortar
Snijden





Optional parts
Choix
Auswahlmöglichkeit
Eleccion
Scelta
Opcao
Keuze





3

Repeat operation
Répéter l'opération
Vorgang wiederholen
Repitir la operacion
Ripetere
Repitir a operação
Herhalen

1 

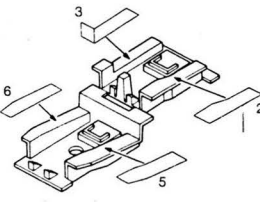
DECAL 1  D2
A9 B19 B20 B18
C2 B12
DECAL 4  B17 B13 Black B13 Black B37
B26 Flat Black Dark grey
Dark grey

■ DECAL POSITION 

2 

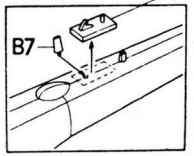
B30 C1
Cockpit inner B27 Dark grey
D1 B27
B7 

■ PILOT PAINTING
 Helmet: Olive drab
 Suit, Glove: Khaki green
 Boots, Harness: Flat black
 Sunglass: Black

3 

B25 B5 A6 B38
Silver
Olive drab
Flat black
Olive drab

4 

A4 B14 A5 B15
Metallic grey
Metallic grey
B32 A3 B39 A2

5 

B35 B34

6 

B8 B9 B10 B28 B6 B8 A10
Olive drab
Metallic grey
Silver
Olive drab
Flat black

7 

E2 E1 Canopy frame :Black
B29 B2 B4 B3
Silver

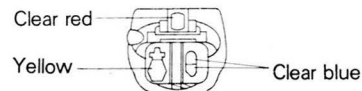
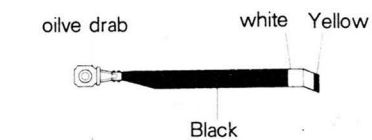
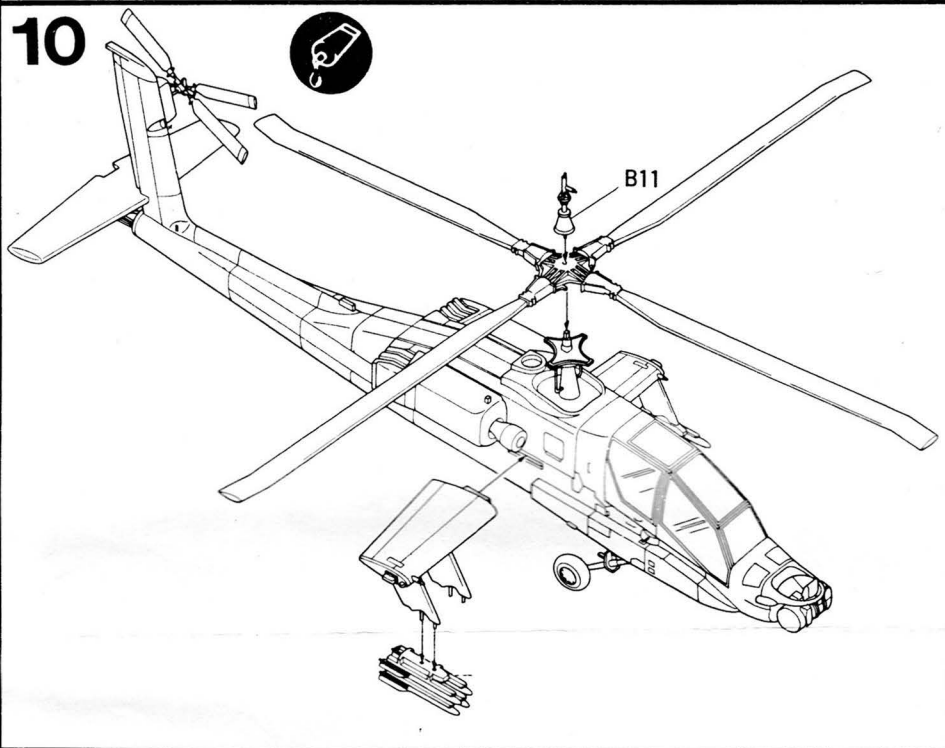
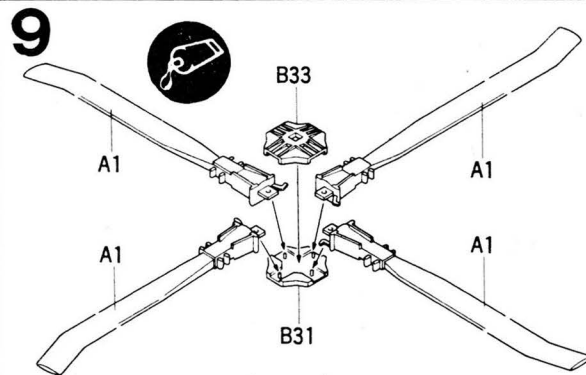
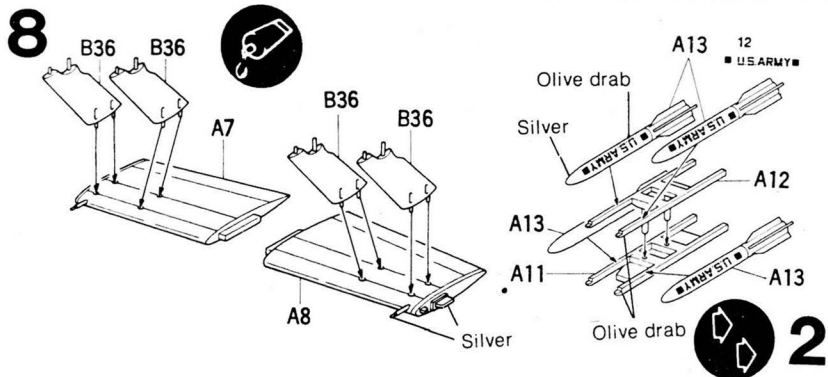

Minicraft Models, Inc.
1510W. 228th St.
Torrance, Calif. 90501

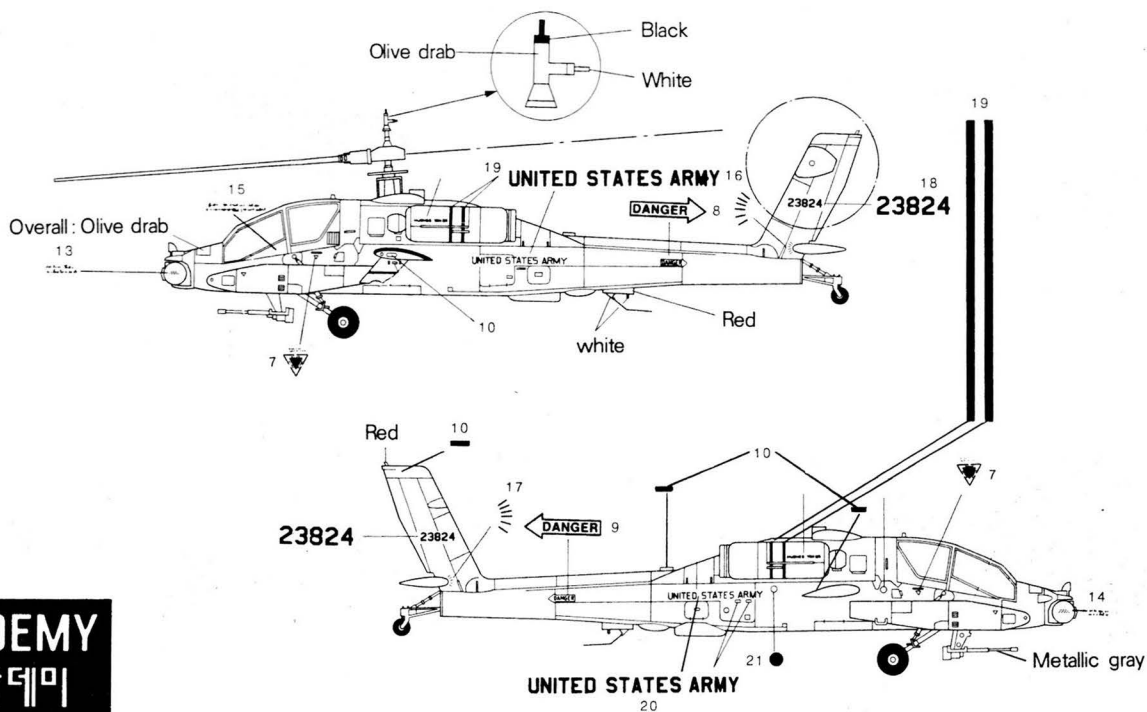

ACADEMY
아카데미
MINICRAFT

Refer to box top for additional paint and decal information

1649
Copyright 1987 Minicraft Models, Inc.



1/48 BELL AH-1G HUEY COBRA 1603

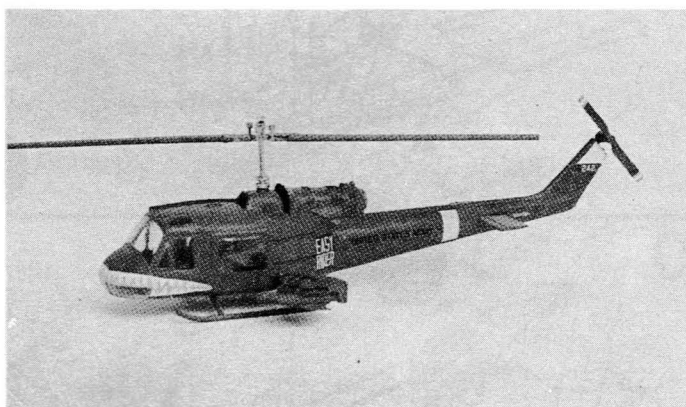

1/48 BELL UH-1B IROQUOIS 1604



1/48 SIKORSKY UH-60A BLACKHAWK 1612



1/48 SIKORSKY HH-60D NIGHTHAWK 1613



1/48 HUGHES 500D PHOENIX POLICE HELICOPTER 1643



1/48 HUGHES 500D-TOW SO. KOREAN HELICOPTER 1644



1/48 HUGHES 500D-ASW REP. OF CHINA ANTI-SUB 1645

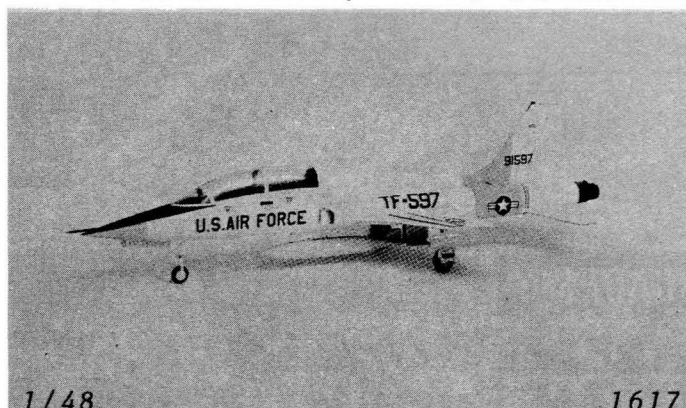

1/48 NORTHROP-38 TALON SUPERSONIC TRAINER 1617