

O Supermarine Spitfire entrou em operação em 1938, sendo usado efetivamente pela RAF até 1954. Sua aparência elegante e excelente performance foram criação de R.J. Mitchell baseado na experiência com hidroaviões de competição. Em seu vôo inaugural, o protótipo, de tão pequeno e rápido, foi considerado "um brinquedo" por um oficial alemão presente. No início da Batalha da Inglaterra, 19 esquadrões tinham recebido o Spitfire num total de 1400 aparelhos. O Spitfire MK II teve 920 unidades produzidas a partir de 1940. Seu motor Merlin RR XII, com a potência aumentada para 1175 Hp, proporcionava uma velocidade máxima de 610 km/h. Este lendário avião não provou ser somente um ótimo caça mas também caça-bombardeiro tático, foto reconhecimento e caça-naval. O Spitfire foi usado, entre outros países, pelos Estados Unidos, Canadá, Rússia e Portugal. Seu armamento inicial era de 8 metralhadoras Browning 303 ou variações com canhões de 20mm e até 1000 libras de foguetes ou bombas. Você pode optar por uma das versões com insígnias de ases famosos incluídas neste modelo.



COLAR



NÃO COLAR



REPITA OPERAÇÃO



PARTE OPCIONAL



PEÇA NO LUGAR



PARTE TRANSPARENTE



APLICAR DECALQUES

<b>A</b> <	<b>B</b> <	<b>C</b> <	<b>D</b> <	<b>E</b> <	<b>F</b> <	<b>G</b> <	<b>H</b> <	
CINZENTO	VERMELHÃO	VERDE ESCURO	MARROM ESCURO	AMARELO	CINZA METÁLICO	ALUMÍNIO	VERDE OLIVA CLARO	
<b>I</b> <	15% +	70% +	<b>J</b> <	<b>K</b> <	<b>L</b> <	<b>M</b> <	<b>N</b> <	<b>O</b> <
VERDE MÉDIO	AMARELO	BRANCO	CINZA ESCURO	PELE	MARROM OLIVA	BRANCO	VERMELHO	VERDE FOLHA

Fabricado e distribuído por  
 A KIKOLER COM. IND. DE PLÁSTICOS S.A.  
 Rua Francisco Portela, 175  
 CEP 21660 - Rio - RJ - Brasil  
 C.G.C. 33.376.666/0001-06  
 Tel.: (021) 390-3540  
 Indústria Brasileira - Made in Brazil



# 1

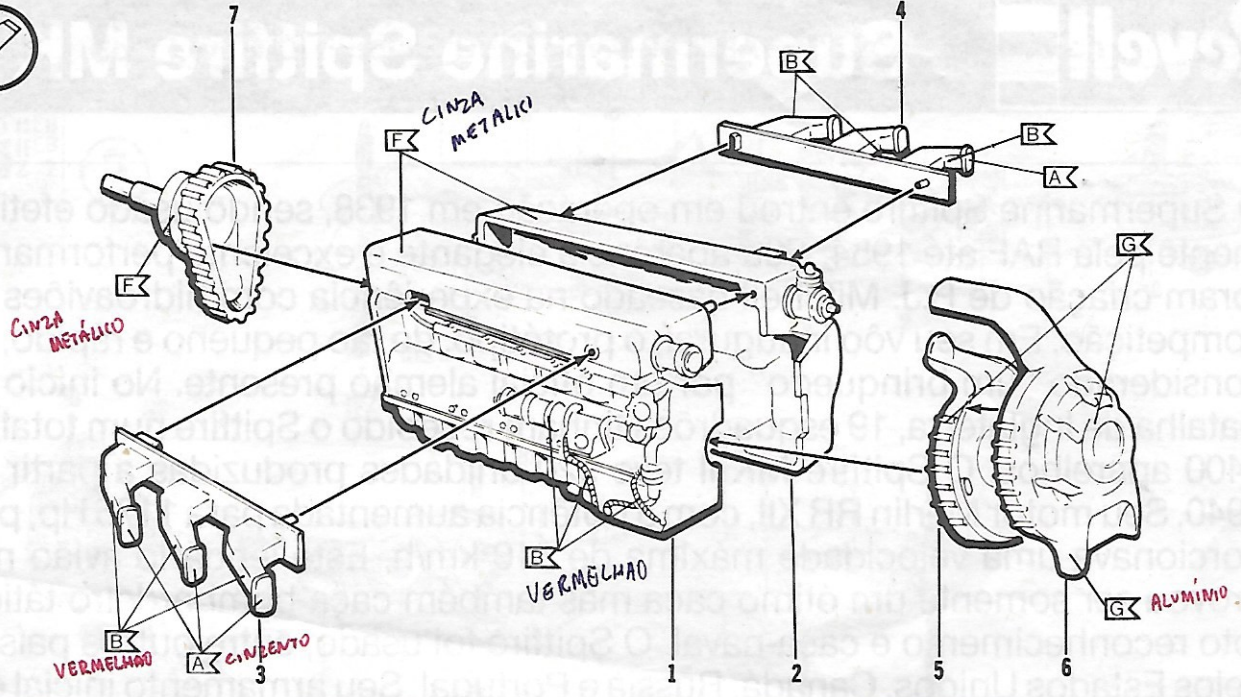

# 2

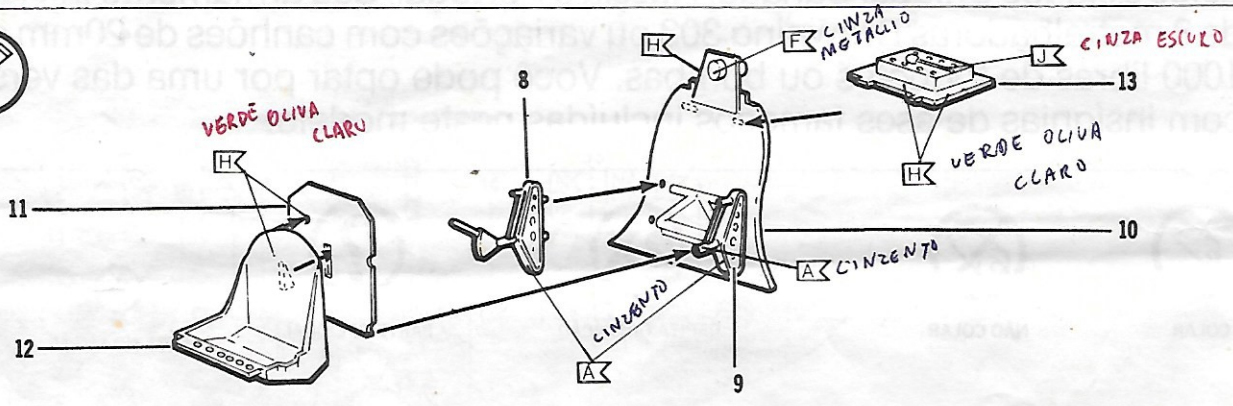

# 3

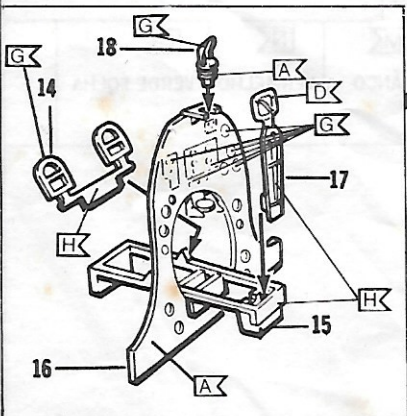
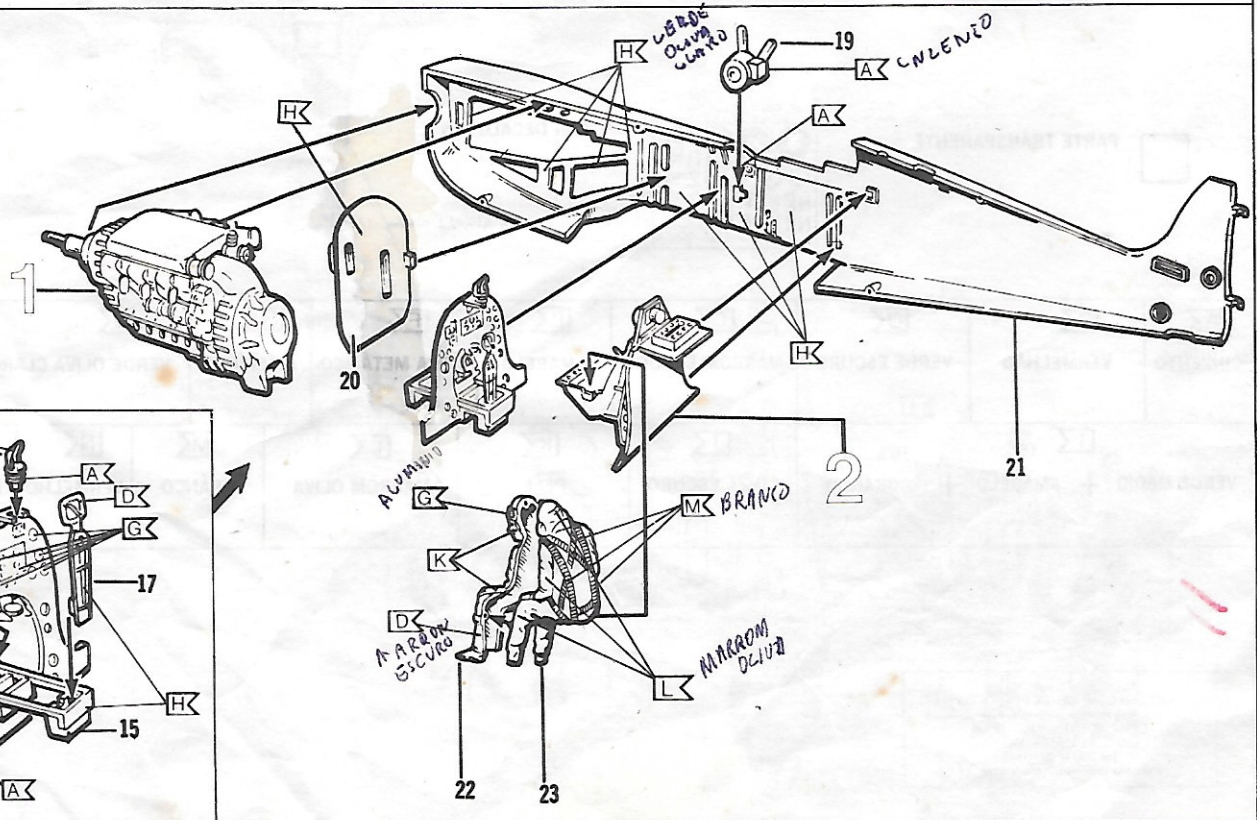



4

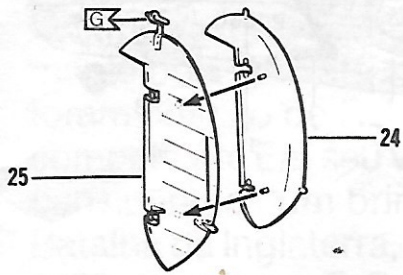

5

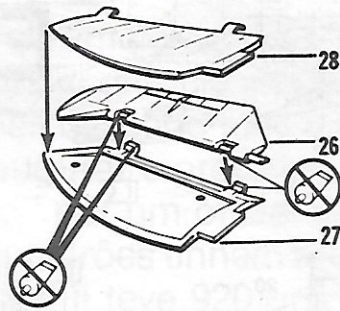

6

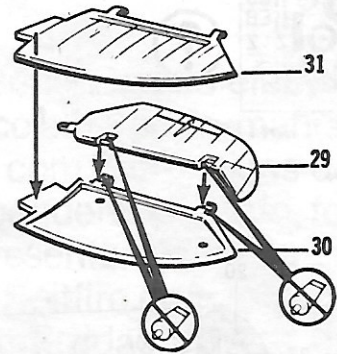

7

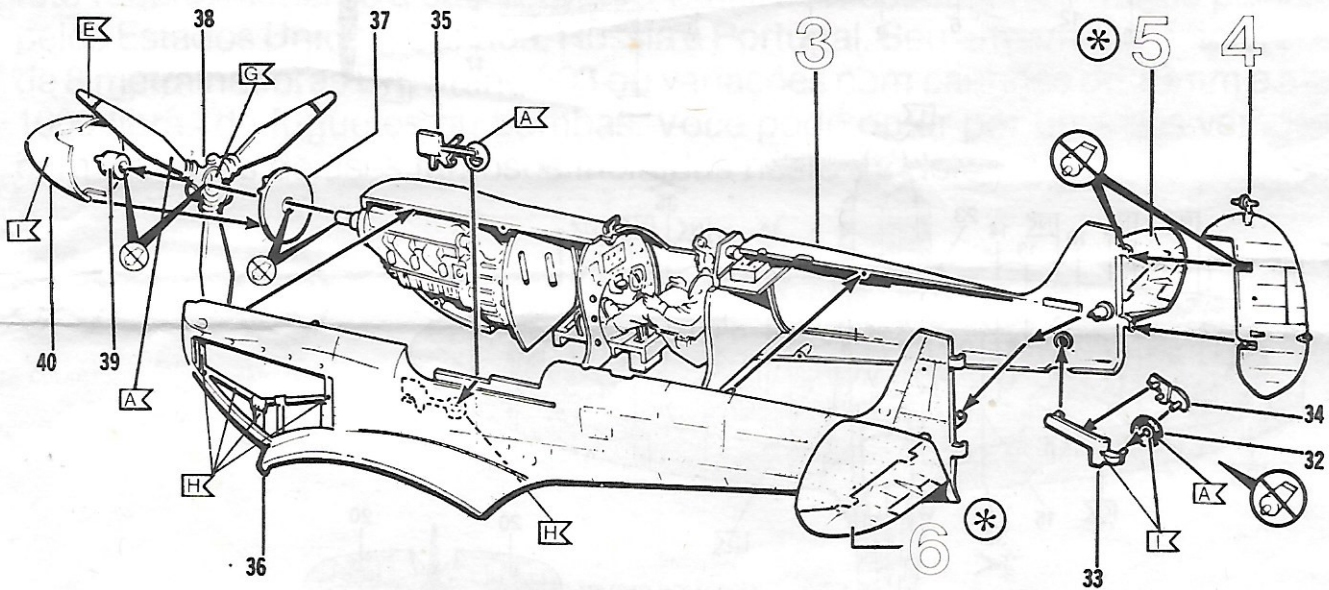

8

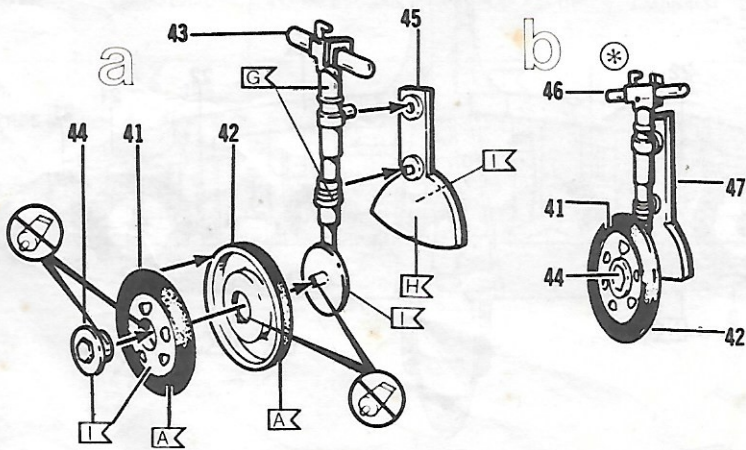

9

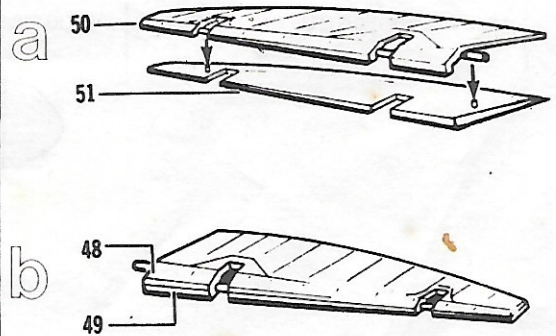



# 10

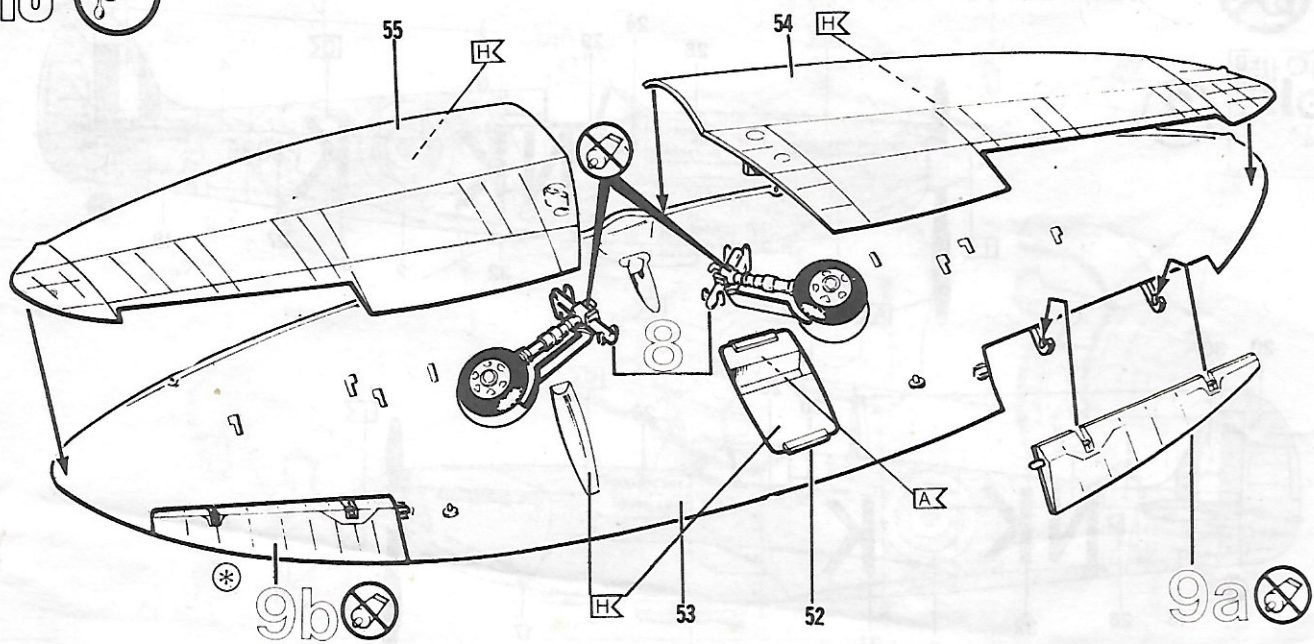

# 11

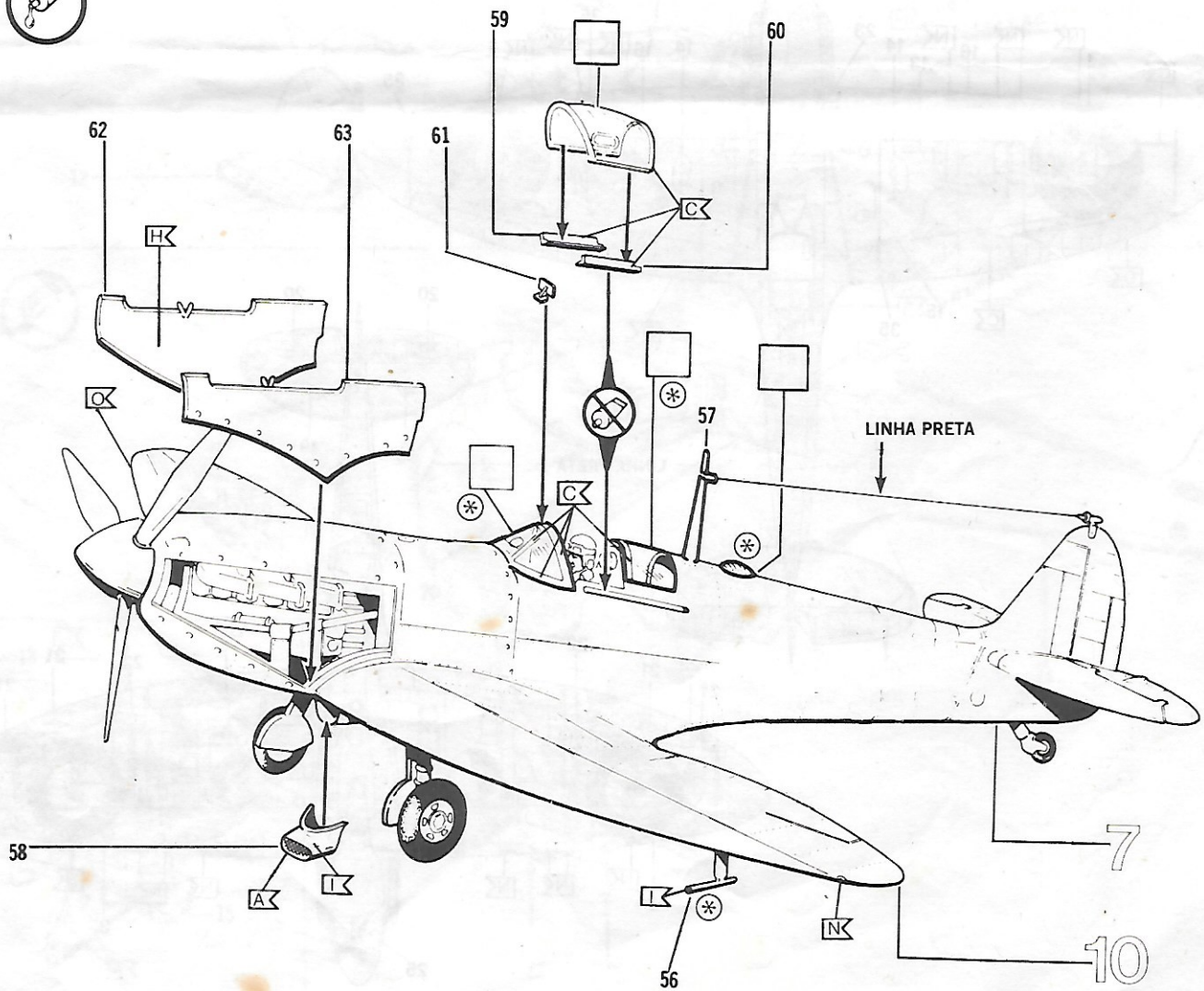



12



# Spitfire MK II A No. 118 (F) Sqn. P.O. A.S.C. Lumsden, Mai 1941 RAF-Station Ibsley, Hants

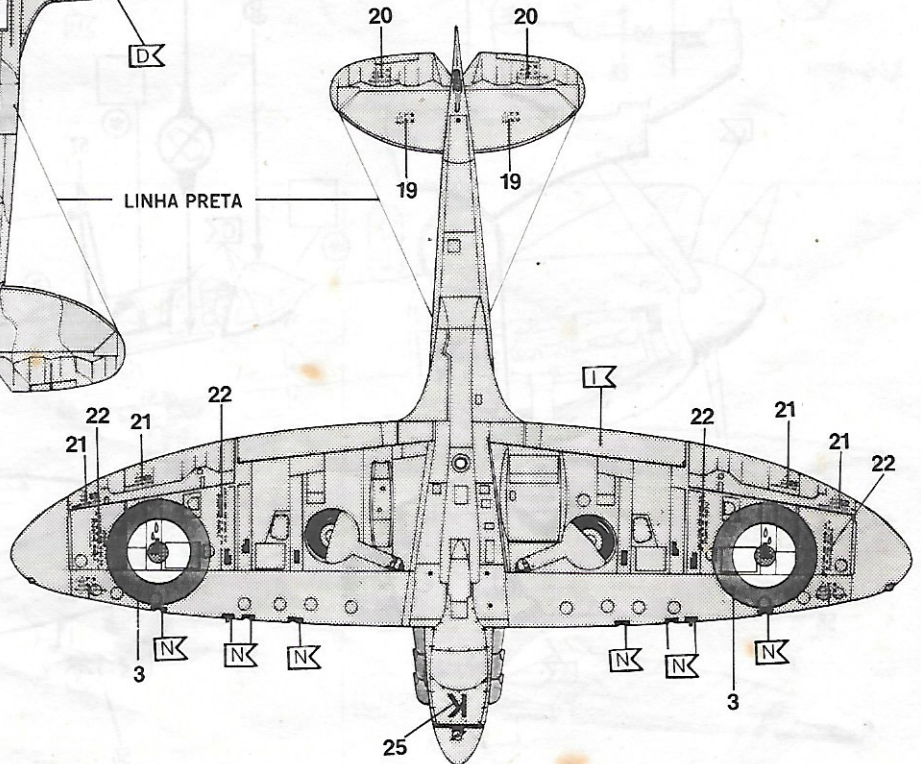
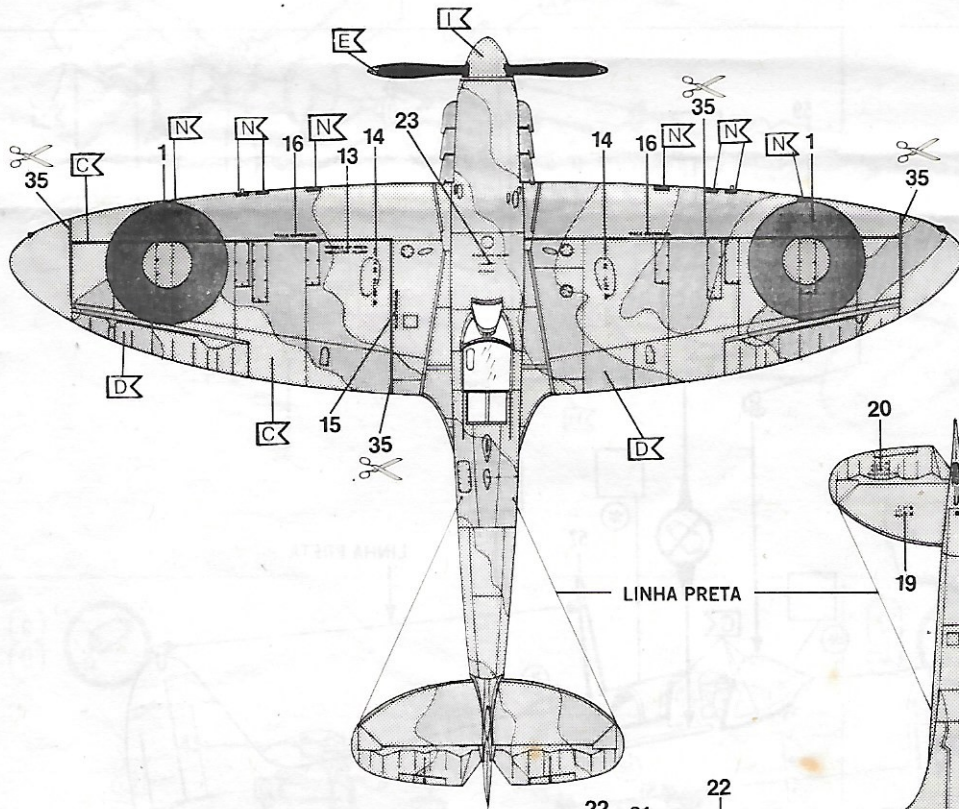
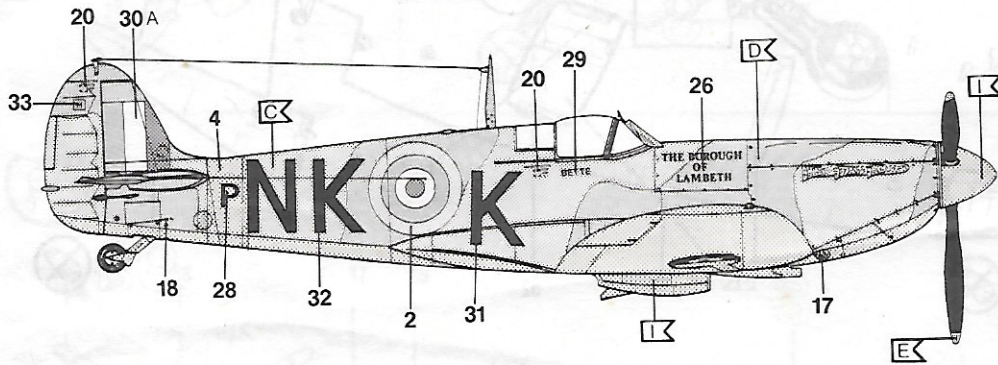
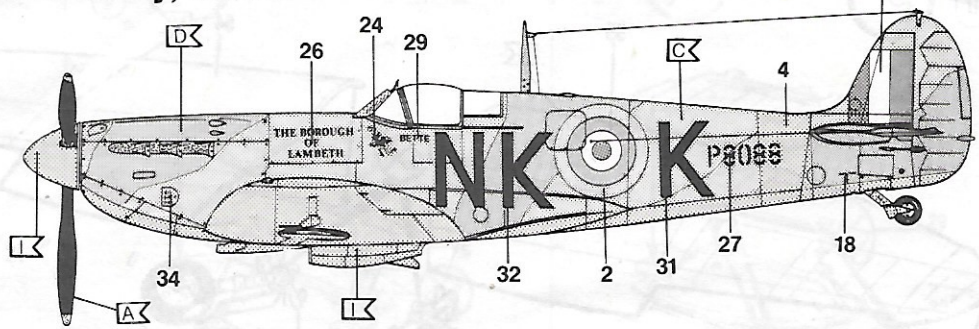



13

# Spitfire MK II A No. 41 (F) Sqn. Sqn. Ldr. D.O. Findlay, DFC, Nov. 1941, RAF-Station Hornchurch

