



MiG-17F

HCI437 • 1:48 • "Flashpoint Fighter"

Kit features: detailed cockpit • landing gear • precise moldings • authentic markings.

Particularités du kit: • l'intérieur détaillé • train d'atterrissage très détaillé • moulage précis • les marques authentiques.

Caratteristiche del modello: • carlinga detagliata e carrello di atterraggio • dettagli incisi • decals autentici.

Der Bausatz enthält: • detailliertes Cockpit und Fahrwerk • fein eingravierte Details • authentische Abziehbilder.

Características del kit: • se detallan la cabina del piloto y el aterrizador • marcas auténticas.

COLOR	FLOQUIL CLASSIC**	HUMBROL**	TESTORS MODELMASTER**
Aluminum	110100	56	1415
	Old Silver	Aluminum	Bare Metal
FS34102 Dark Green	303343	117*	1713
	US Green FS34102	Matt US Light Green	Med. Green

*Approximate Match. **Some paints may not be available in your country. Please check with your local hobby shop for substitute colors.

cyanoacrylate glue coller cyanoacrylate Cyanoacrylate kleben incollare cyanoacrylate pegar cyanoacrylate	cut couper schneiden tagliare cortar	bend plier sich biegen plegar doblar	file / sand ponce verspachteln levigare lijar	weight a lestir Gewicht zavorra lastre	drill or pierce percer bohren forare agujerear	x2 two deux zwei due dos
photoetched photogravées Photoätzteile foto incisa fotograbadse	caution! attention! vorsicht! attenzione! atención	alternative en option Alternativ alternativo alternativa	cement coller kleben incollare pegar	paint peindre bemalen vernicare pintar	decal decalcomania Abziehbild decalcomania calcomanias	no! no! nein! no! no!



Read This Before You Begin!

- study the assembly drawings
- each plastic part is identified by a number
- check the fit of each piece before cementing
- do not use too much cement to join parts
- model may be painted to match box illustration

Lisez Ce Qui Suit Avant De Commencer Le Montage!

- étudier les schémas d'assemblage
- chaque pièce plastique porte un numéro d'identification
- contrôler que chaque pièce soit bien conforme avant de la coller à sa place
- utilisez uniquement une colle spéciale pour polystyrène
- le model peut être peint conformément aux illustrations de la boîte

Vor Zusammenbau lesen sie bitte!

- studiere die Bauanleitung
- die Plastikteile sind gekennzeichnet durch ihre Nummern
- vor dem Kleben prüfe ob die Teile zusammenpassen können
- benutze nicht zuviel Klebstoff
- die Bemalung des Modells kann auf dem Becketbild zeigen

1

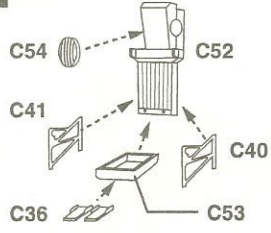

2

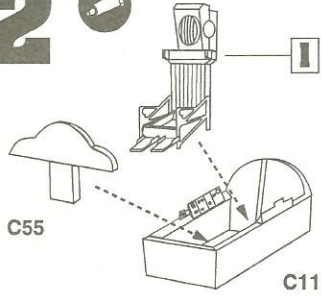

MiG-17F COCKPIT COLORS:

- sidewalls: turquoise
- instruments: black
- seat: gray & brown details

3

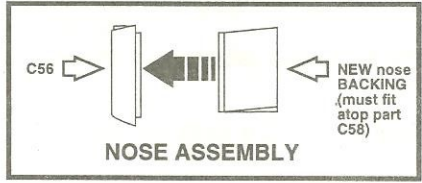

SOME COCKPIT DETAILS OMITTED FOR CLARITY!

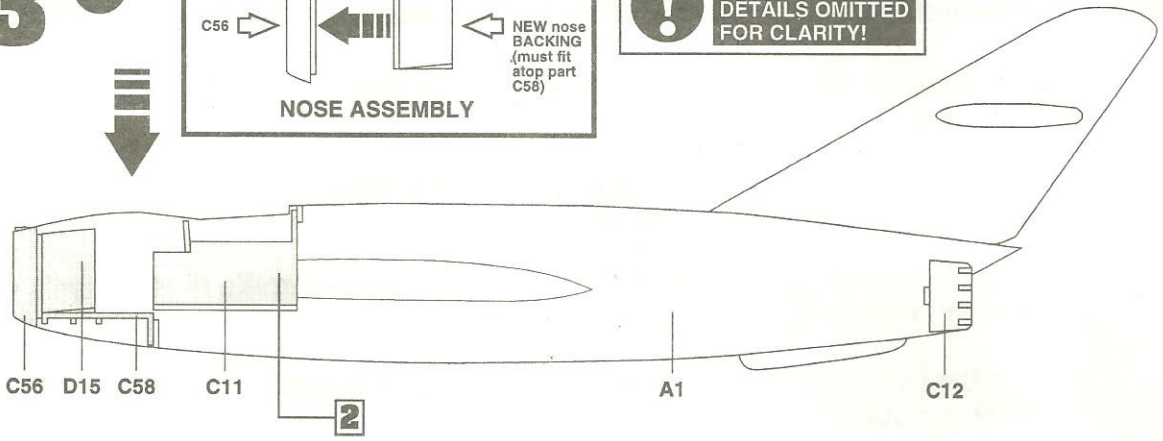

4

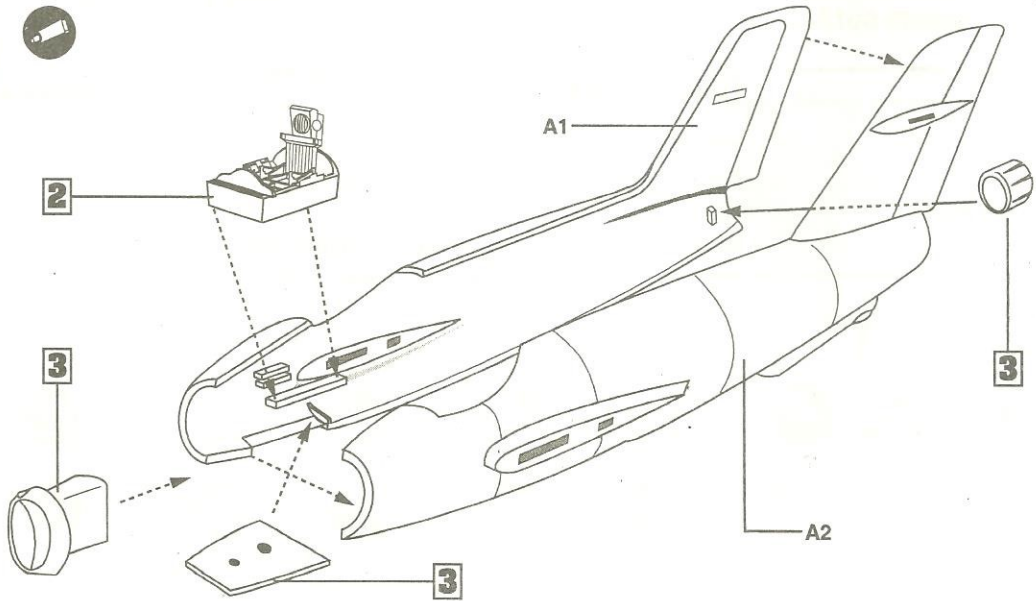

5



open for rockets

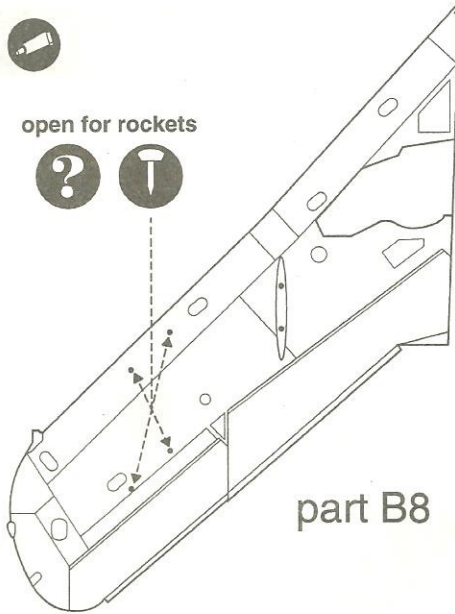

part B8

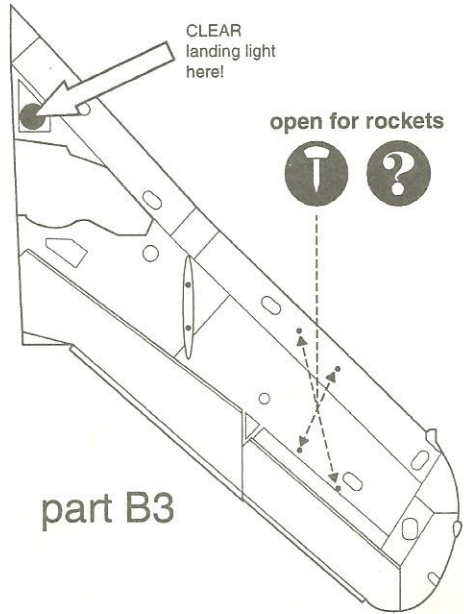

part B3

6

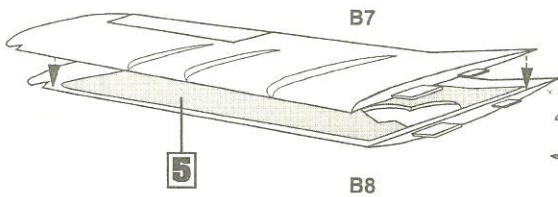

B8

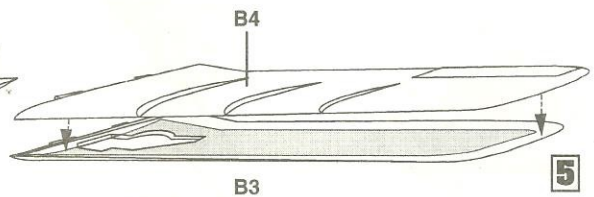

B3

7

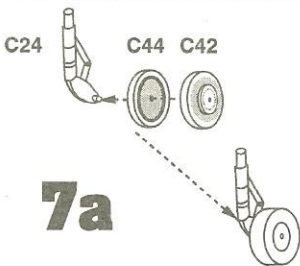

7a

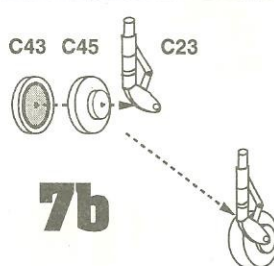

7b

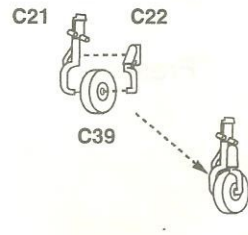

8

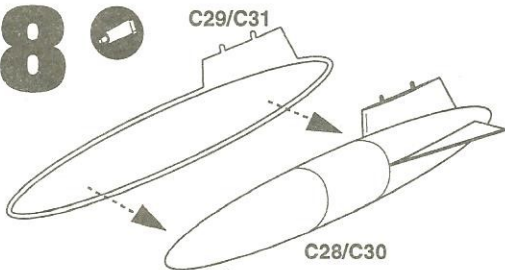

C28/C30

9

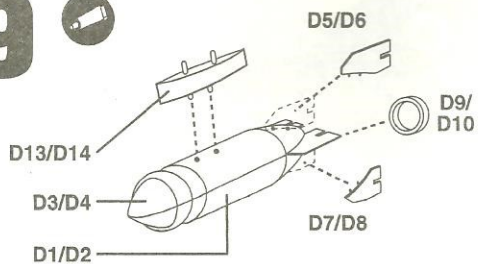

10

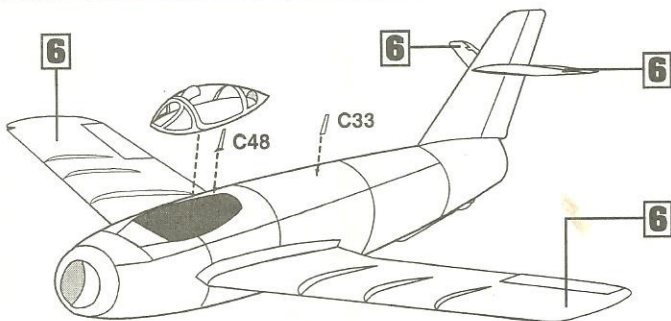
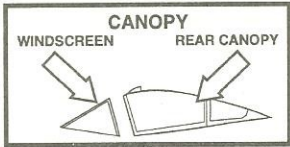

11

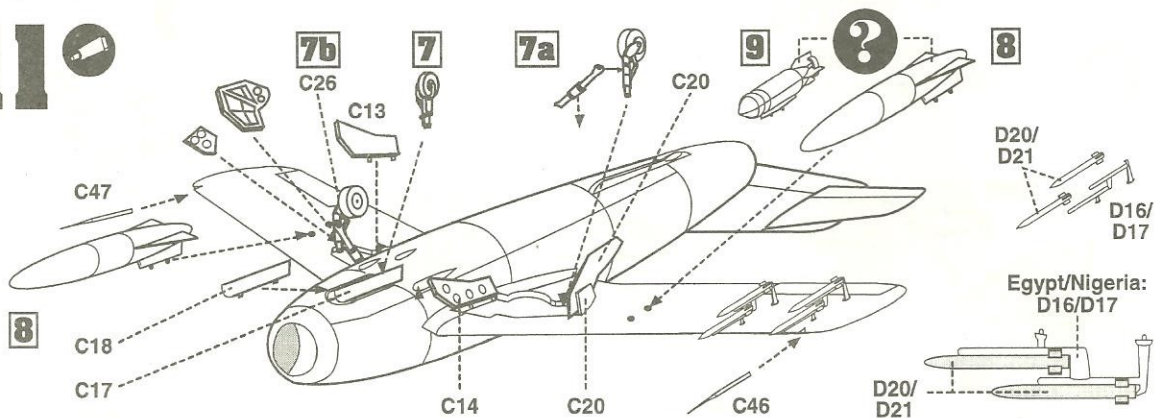

12

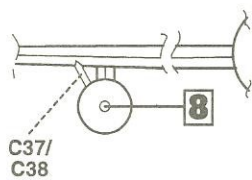

13

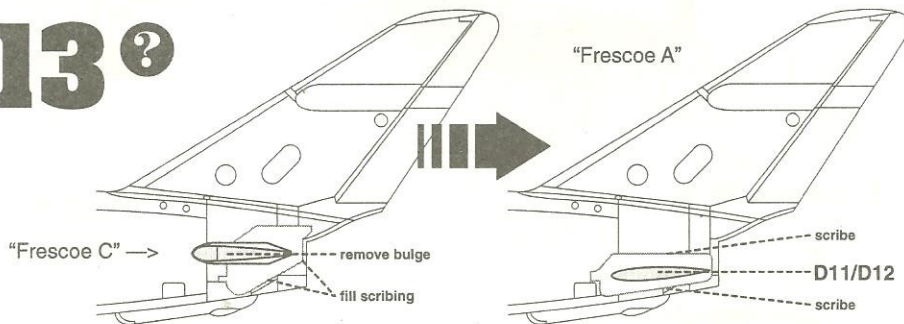

14

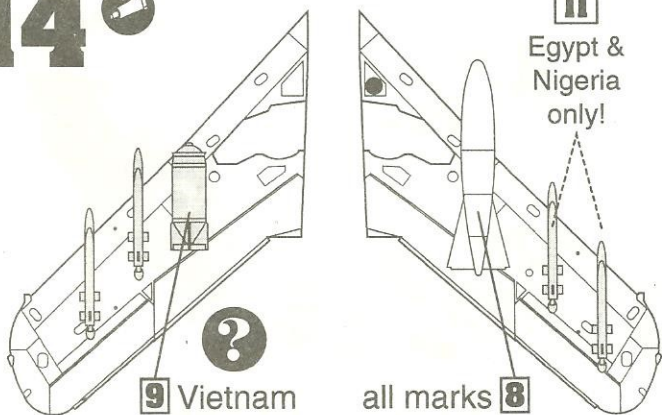

15

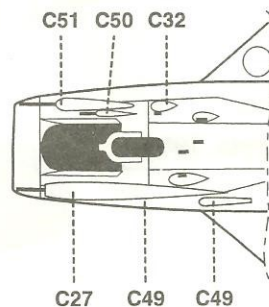

MiG-17F "Flashpoint"

Markings • Appliques



1. Vietnam, 1972

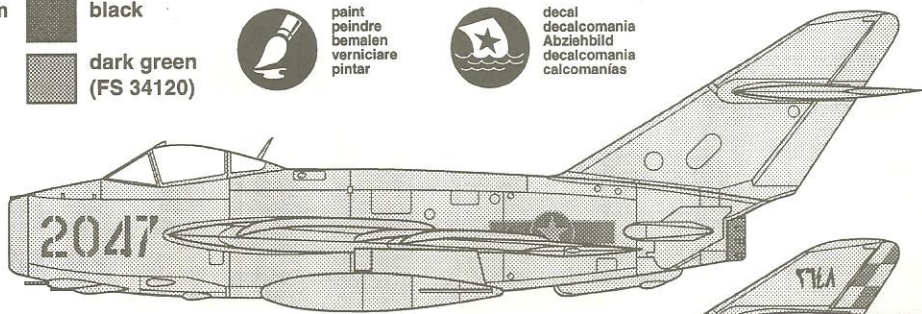

2. Egypt, 1967

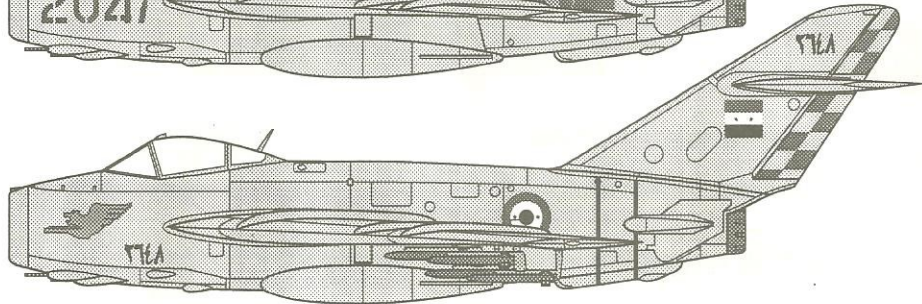
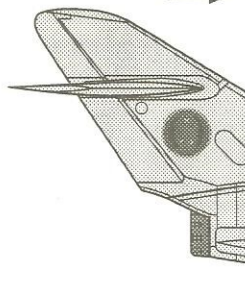

3. Congo, 1997

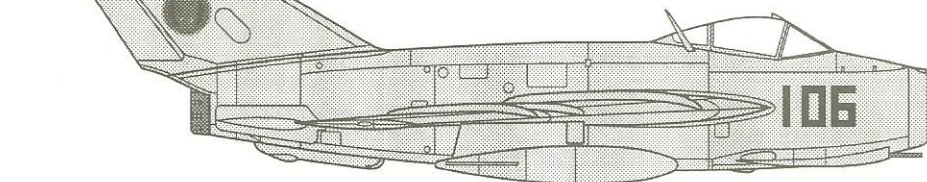

4. Somalia, 1976(?)

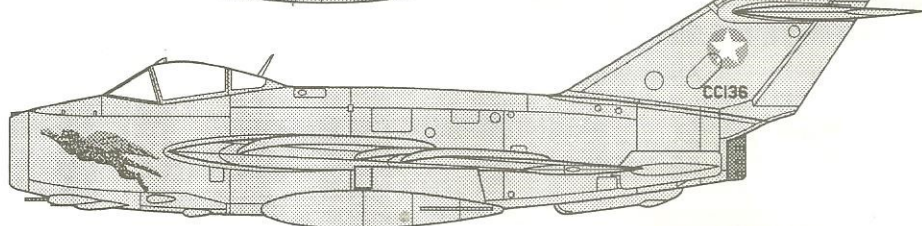
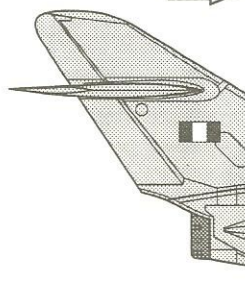

5. Nigeria, 1969

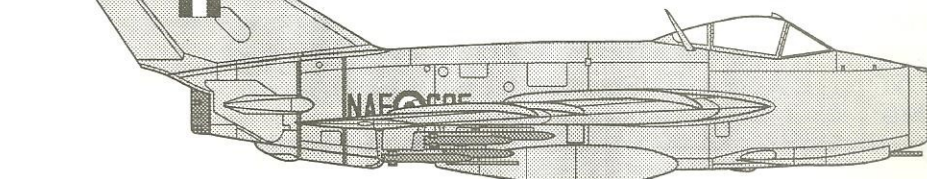

6. Nigeria, 1969

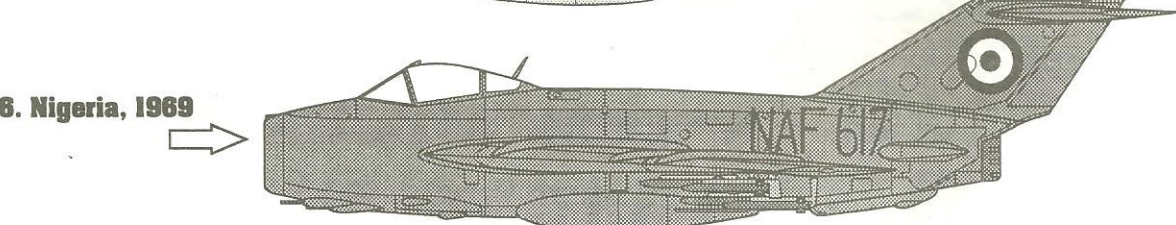

SPECIAL THANKS TO MR. KEITH SISSONS FOR HIS KIND ASSISTANCE!

MiG-17F "Flashpoint"

Markings • Appliques

TOP = BOTTOM • LEFT = RIGHT

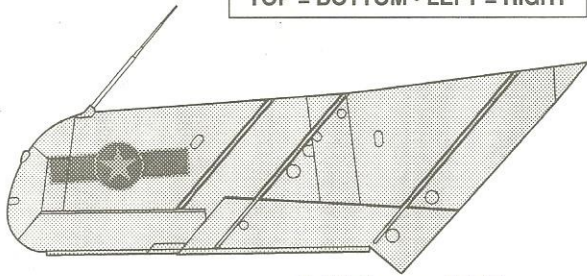

1. Vietnam, 1972

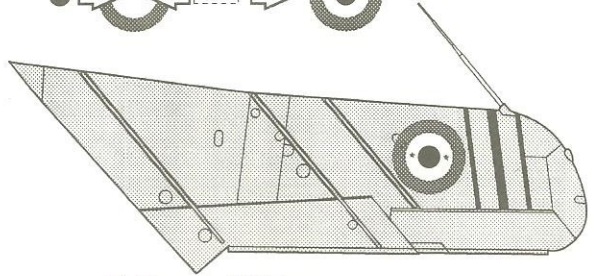

2. Egypt, 1967

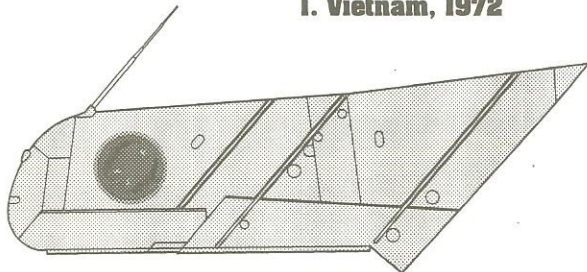

3. Congo, 1997

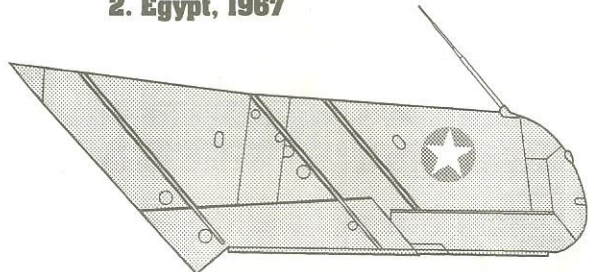

4. Somalia, 1976(?)

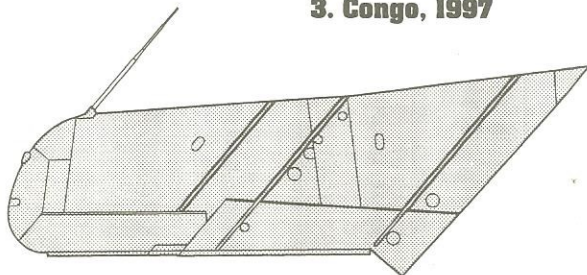

5. Nigeria, 1969

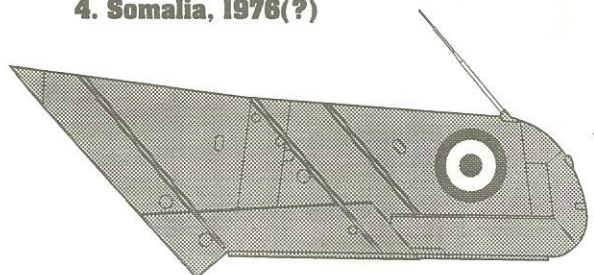

6. Nigeria, 1969

"Frescoe C"

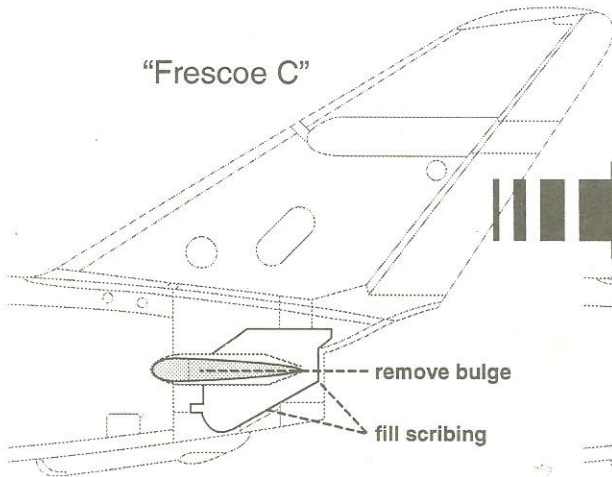

"Frescoe A"

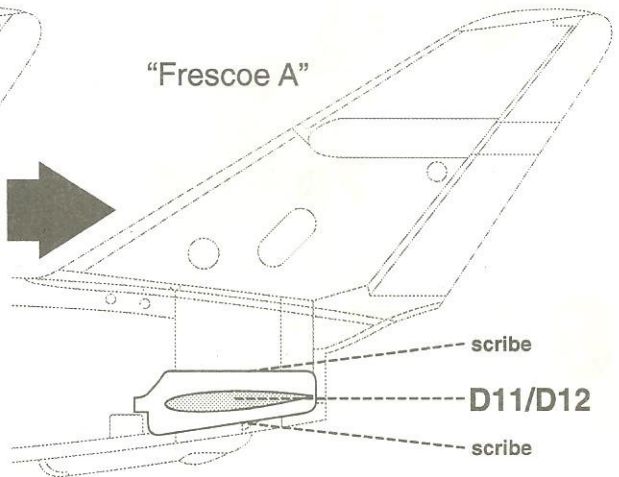

1/48 airbrake scribing templates →

