

MONOGRAM

KIT 5614

85561400200

B-17G FLYING FORTRESS

The B-17G is the most famous bomber of all time. Powered by four 1200 hp Wright Cyclone engines, this was the toughest, strongest, and most reliable bomber of the U.S. Army Air Corps in WWII.

Your Revell model has a superbly detailed interior that is visible through a transparent port side-half of the fuselage. This fuselage-half, complete with panel-joint and rivet detail, is molded in clear plastic to show the realistic interior details of the cockpit, bomb bay and compartments for the navigator, radio operator, gunners and bombardier. Kit also includes an optional opaque fuselage-half, which may be assembled in place of the clear half if desired.

Rotating gun turrets and spinning propellers, bombs and bomb cart and detailed figures of crewmen are also included, as well as authentic waterside WWII insignia decals.



* REPEAT SEVERAL TIMES
* A REPETER PLUSIEURS FOIS

* OPTIONAL PARTS
* PIECES EN OPTION

* DECAL
* DECAL COMANIE

* ALTERNATIVE ASSEMBLY
* ENSEMBLAGE ALTERNATIVE

* CEMENT TOGETHER
* A COLLER

* REMOVE AND THROW AWAY
* A RETIRER ET JETER

* DO NOT CEMENT
* NE PAS COLLER

READ THIS BEFORE YOU BEGIN

- Study the assembly drawings.
- Each plastic part is identified by a number.
- In the assembly drawings, some parts will be marked by a star (★) to indicate chrome plated plastic.
- For better paint and decal adhesion, wash the plastic parts in a mild detergent solution. Rinse and let air dry.
- Check the fit of each piece before cementing in place.
- Use only cement for polystyrene plastic.
- Scrape plating and paint from areas to be cemented.
- Allow paint to dry thoroughly before handling parts.
- Any unused parts may be discarded.

DECAL APPLICATION INSTRUCTIONS

1. Cut desired decal from sheet.
2. Dip decal in water for a few seconds.
3. Place wet decal on paper towel.
4. Wait until decal is movable on paper backing.
5. Place decal in position on model, face up and slide backing away.
6. Press out air bubbles with a soft damp cloth.
7. Milkyness that may appear is for better decal adhesion and will dry clear. Wipe away any excess adhesive.
8. Do not touch decal until fully dry.
9. Allow the decals 48 hours to dry before applying clear coat.

NOTE: Decals are compatible with setting solutions or solvents.

LIRE CE QUI SUIT AVANT DE COMMENCER

- Etudier les schémas de montage.
- Chaque pièce en plastique est identifiée par un numéro.
- Sur les schémas de montage, certaines pièces sont marquées d'une étoile (★) pour indiquer qu'elles sont en plastique chromé.
- Pour une meilleure prise de la peinture et des autocollants, laver les pièces en plastique avec une solution détergente peu concentrée. Les rincer et les laisser sécher à l'air.
- Vérifier que chaque pièce s'ajuste bien avant de la coller en place.
- N'utiliser que de la colle pour polystyrène.
- Gratter les parties à coller pour enlever le chrome et la peinture.
- Laisser la peinture bien sécher avant de manipuler les pièces.
- Toute pièce inutilisée peut être jetée.

DIRECTIVES D'APPLICATION DES AUTOCOLLANTS

1. Découper l'autocollant désiré de la feuille.
2. Tremper l'autocollant dans de l'eau pendant quelques secondes.
3. Placer l'autocollant mouillé sur une serviette en papier.
4. Attendez que l'autocollant puisse être déplacé sur son support en papier.
5. Mettre l'autocollant en position sur le modèle face sur le dessus et faire glisser le support pour l'enlever.
6. Appuyer avec un chiffon doux humide pour éliminer les bulles d'air.
7. La substance laiteuse qui peut apparaître est destinée à améliorer l'adhésion de l'autocollant et devient incolore au séchage. Essuyer pour enlever tout excédent d'adhésif.
8. Ne pas toucher l'autocollant tant qu'il n'est pas bien sec.
9. Laisser l'autocollant sécher pendant 48 heures avant d'appliquer une couche transparente.

REMARQUE: Les autocollants sont compatibles avec les solutions de fixation ou les solvants.

This paint guide is provided to complete this kit as shown on the box.

Ce guide de peintures est fourni pour reproduire le modèle réduit qui apparaît sur la boîte.

Blue	Bleu
Red	Rouge
Aluminum	Aluminium
Semi Gloss Black	Noir satiné
Brass	Laiton
Gun Metal	Bronze
Olive Drab	Gris vert
Natural Wood	Bois
Medium Gray	Gris moyen
Light Green	Vert clair
Flat Black	Noir mat
Light Gray	Gris clair
Zinc Chromate Green	Vert chromate de zinc
Tan	Havane
Flat White	Blanc mat
Flat Brown	Brun clair mat
Yellow	Jaune

If you have any questions or comments, call our hotline at: **(800) 833-3570** or, please write to:

Revell-Monogram Consumer Service Department, 725 Landwehr Road, Northbrook, Illinois 60062

Be sure to include the plan number (85561400200), part number, description, your return address and phone number.

Visit our website: www.revell.com

1

FIGURES

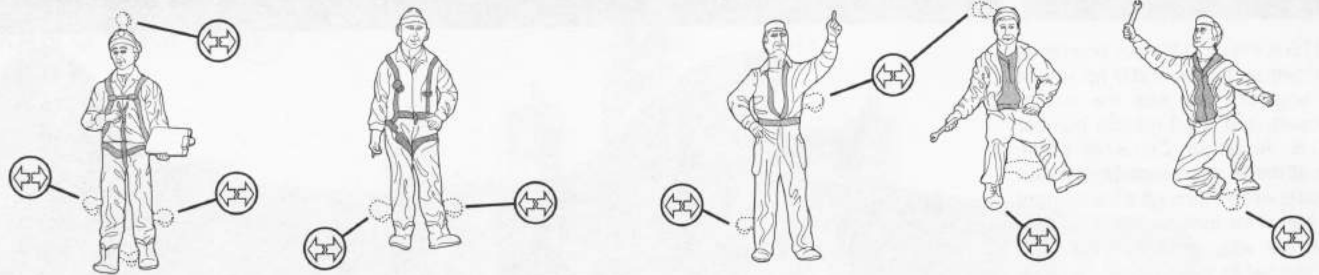

The **Flight Officer** and **Flight Crew** members wore khaki uniforms including the shirt and pants. The jackets were dark brown leather, while the "Mae West" life vests were yellow. Straps were a dirty white or light gray in most cases, but some were tan. The buckles on the straps were silver. Both style of caps were brown, and the saucer cap worn by the flight officer had a brown leather bill. The clipboard was normally dark brown with a silver clip. The boots were brown leather with an off-white fleece lining at the top.

The aircraft **Service Mechanics** wore olive drab, gray, or khaki coveralls and fatigues that were usually quite greasy and dirty from working on the aircraft. Olive green jackets were sometimes worn. Standard issue caps were olive drab, but various units had caps of almost any color to inspire unit identity and pride. The boots were brown leather. The wrench the men are holding would have been silver or a dark gray color.

2

FLIGHT CREW FIGURES



PILOT



CO-PILOT

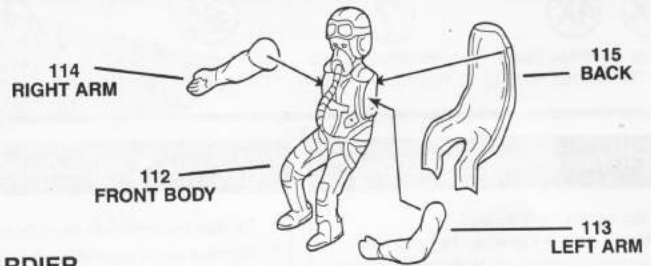

BOMBARDIER



SQUATTING
WAIST GUNNER

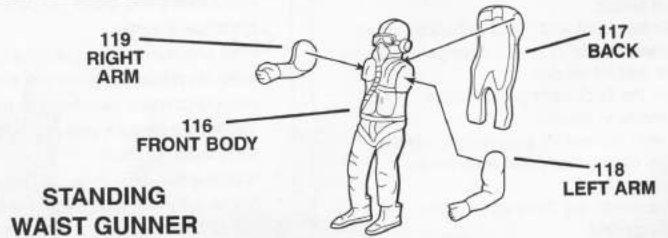

STANDING
WAIST GUNNER

3

SIDEVIEW OF B-17

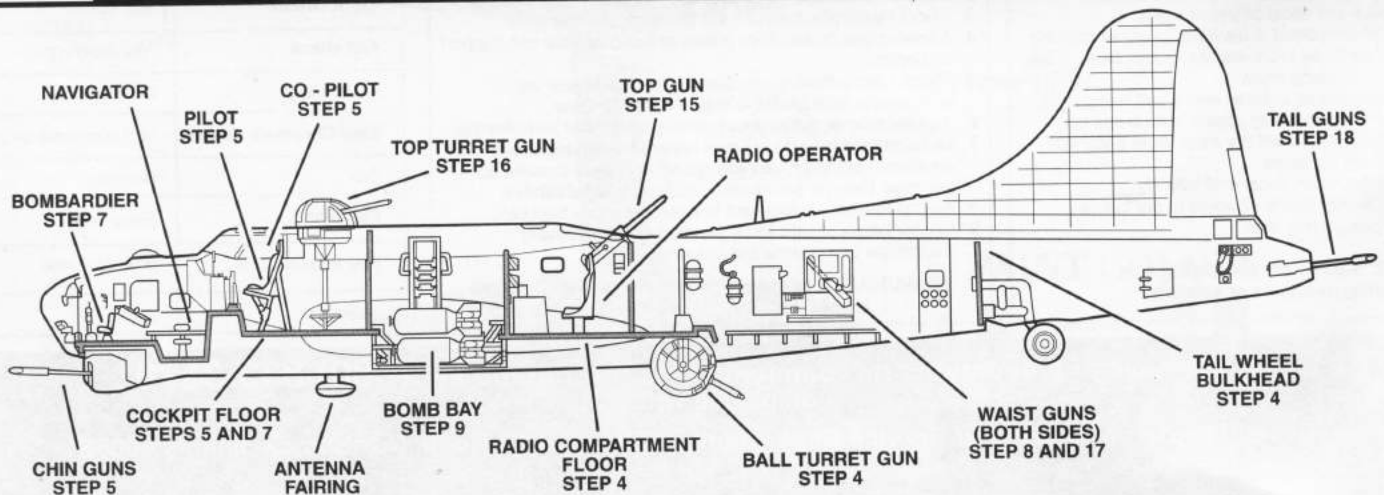

4

RADIO ROOM ASSEMBLY

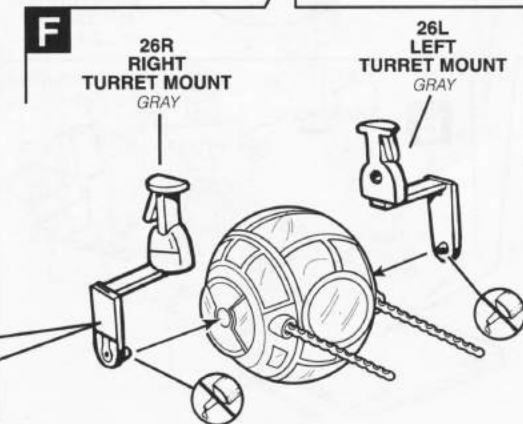
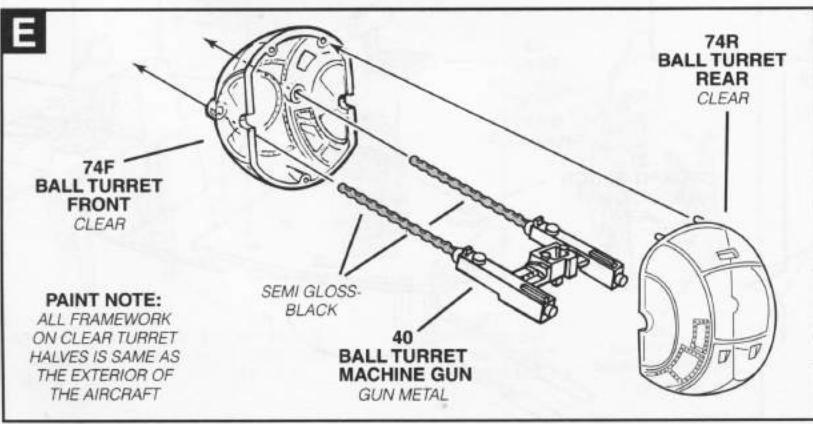
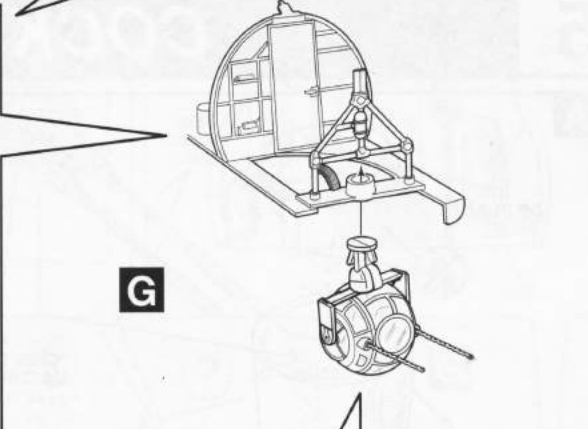
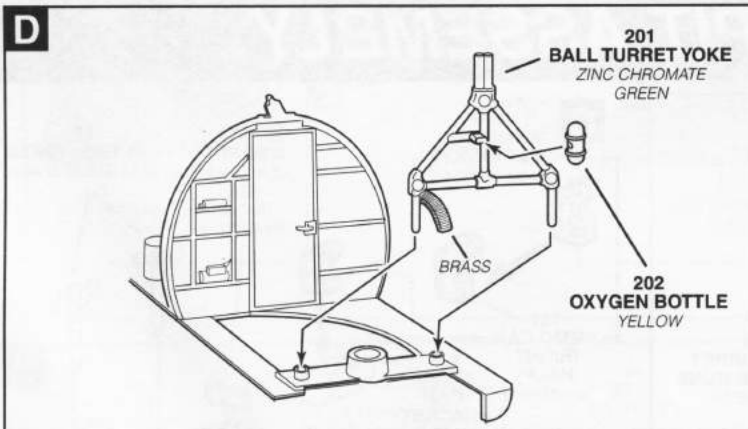
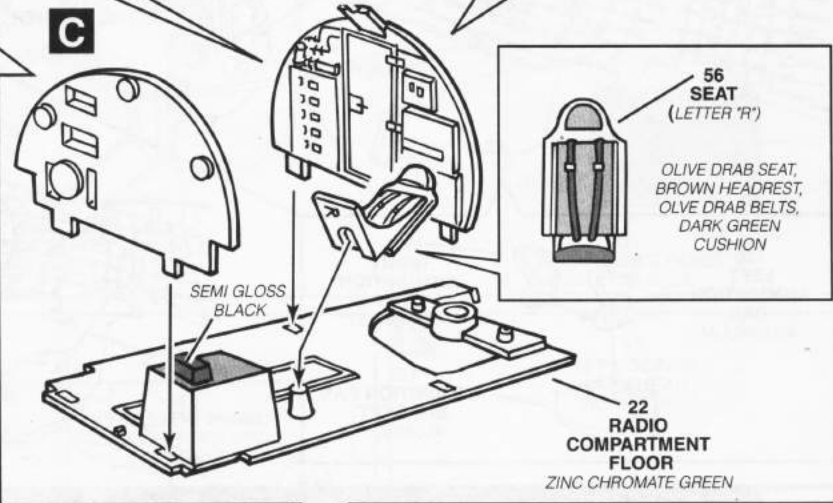
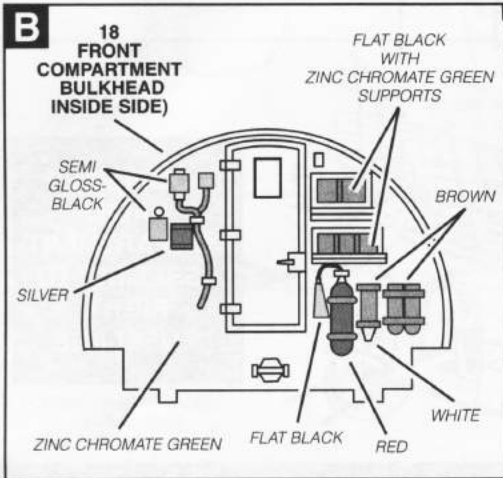
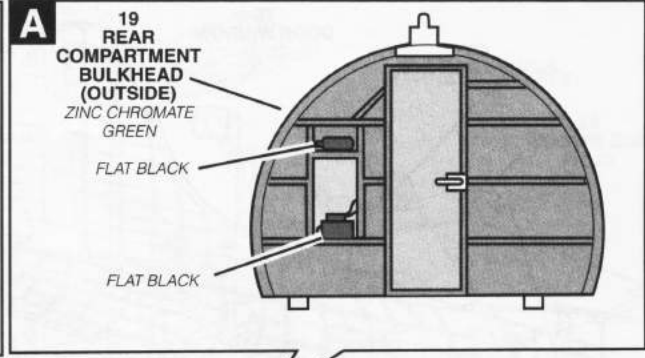
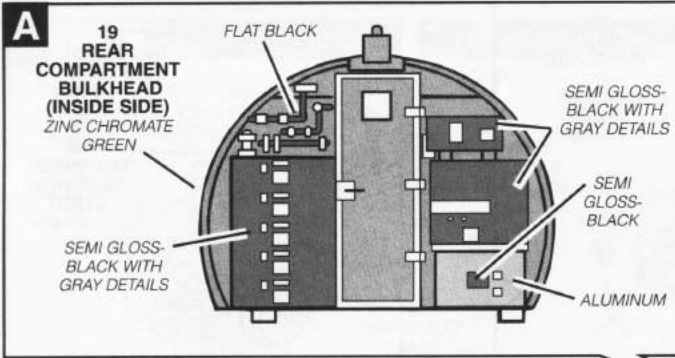

4

RADIO ROOM ASSEMBLY CONTINUED

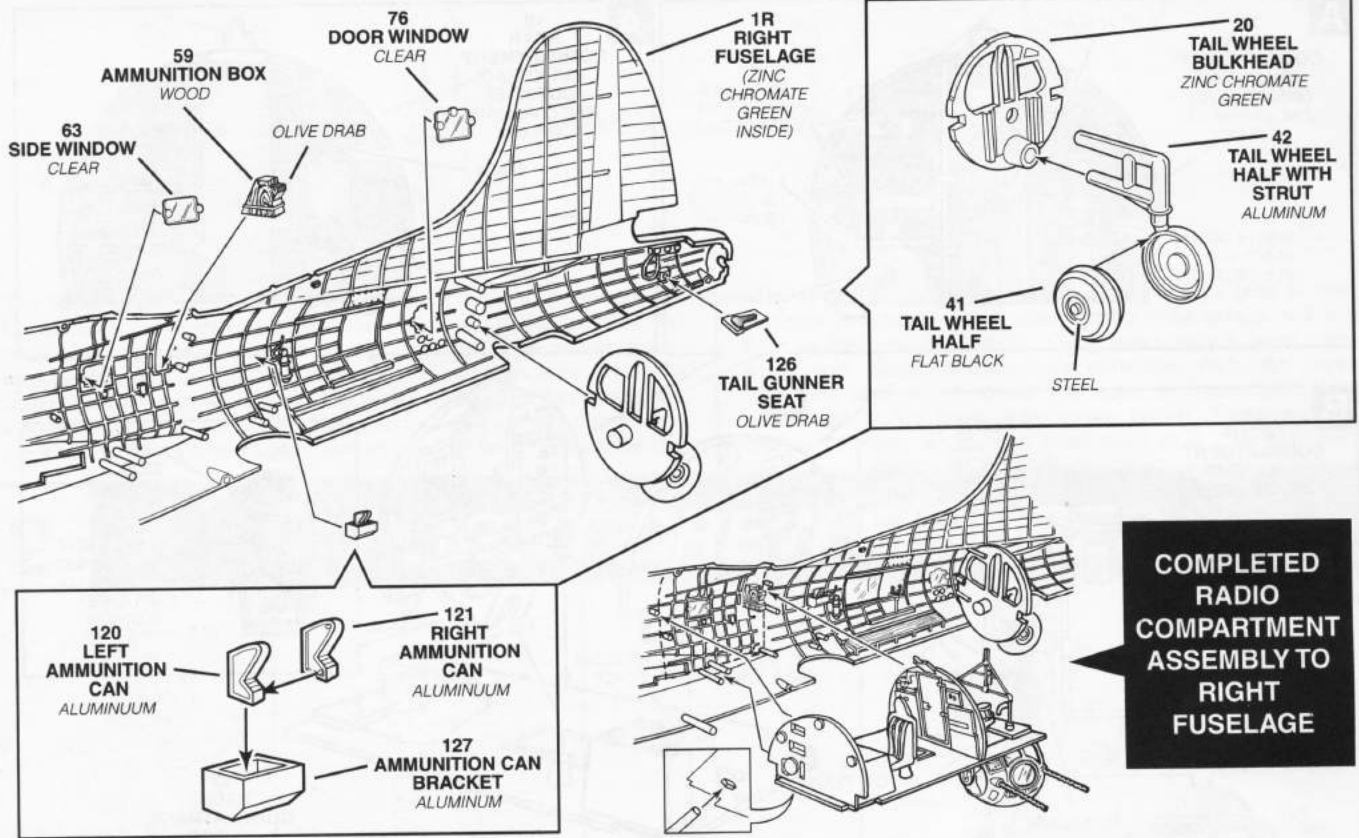

5

COCKPIT ASSEMBLY

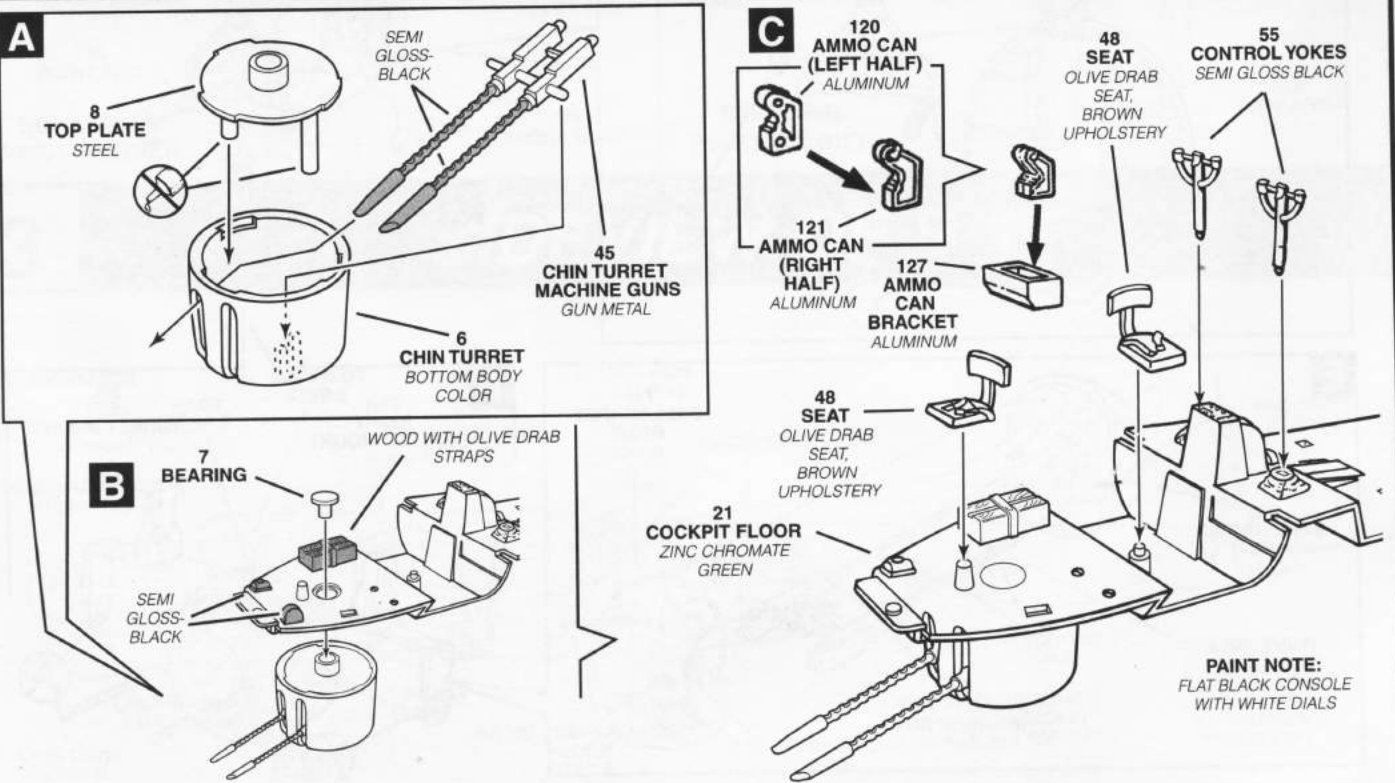

5

COCKPIT ASSEMBLY CONTINUED

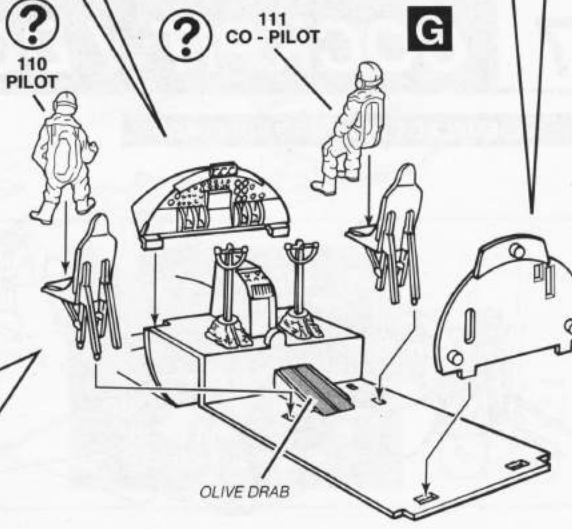
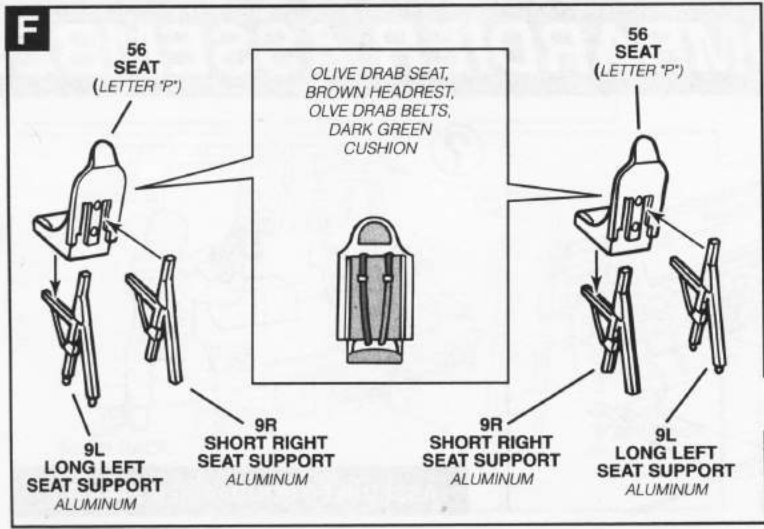
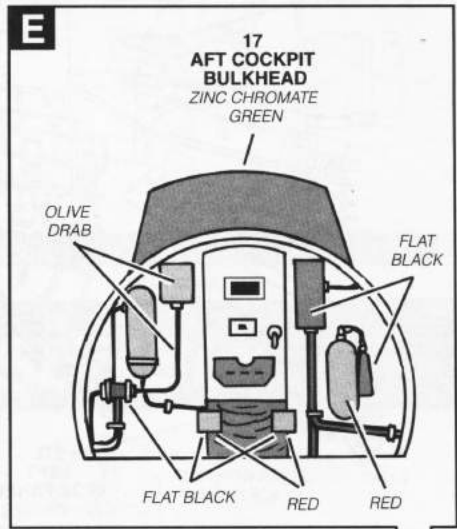
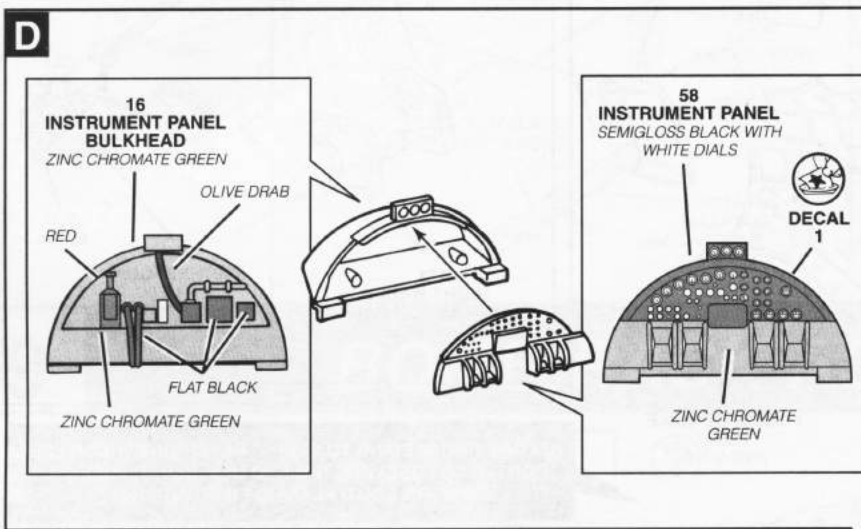
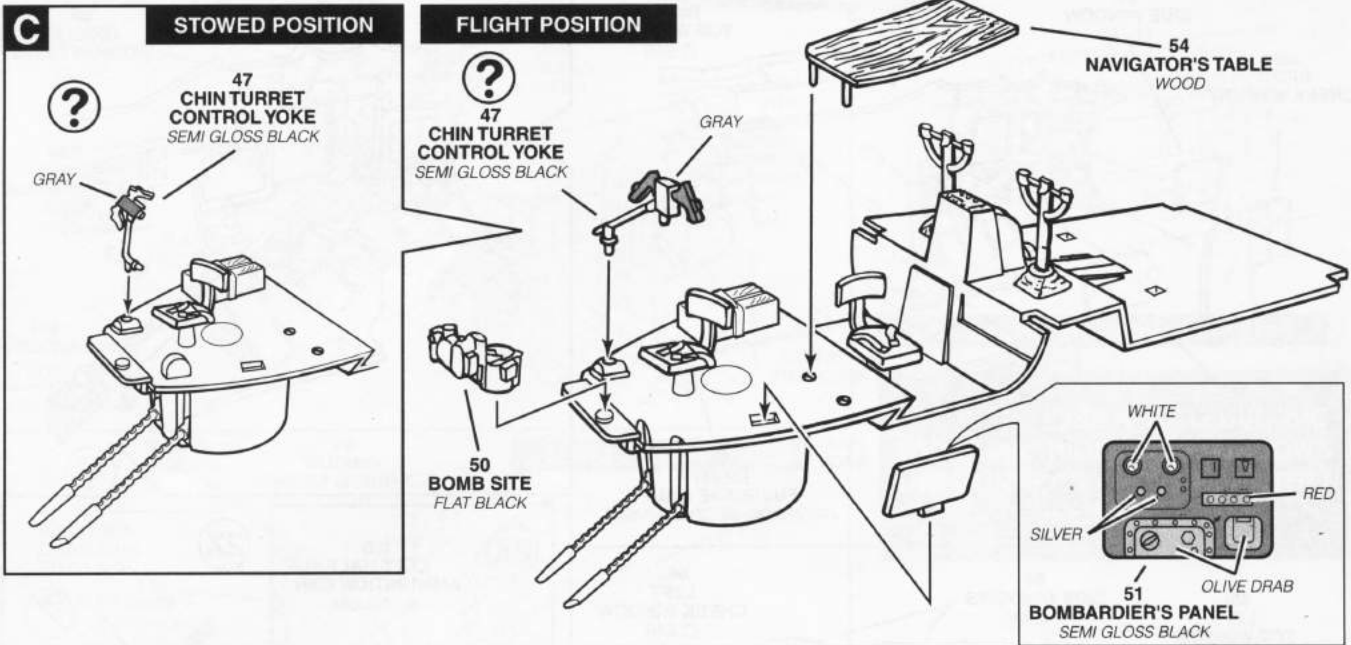

6

FRONT WINDOW / GUN ASSEMBLY

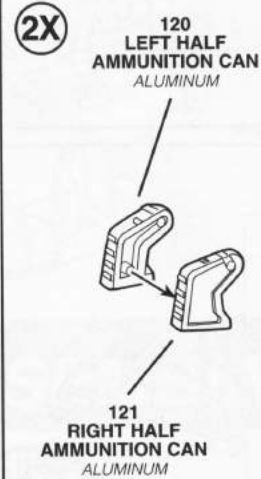
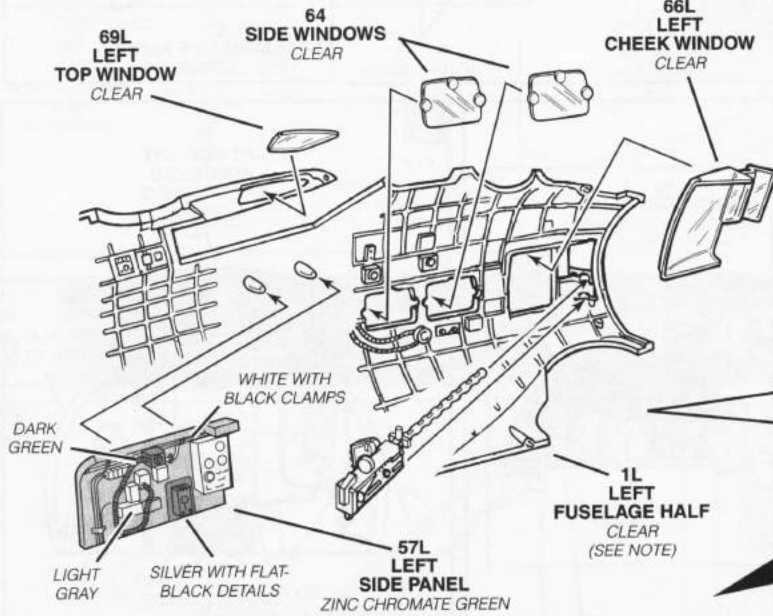
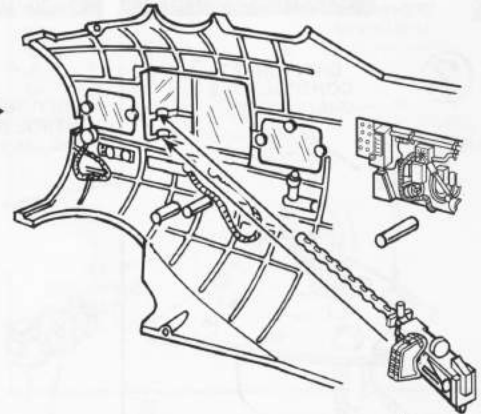
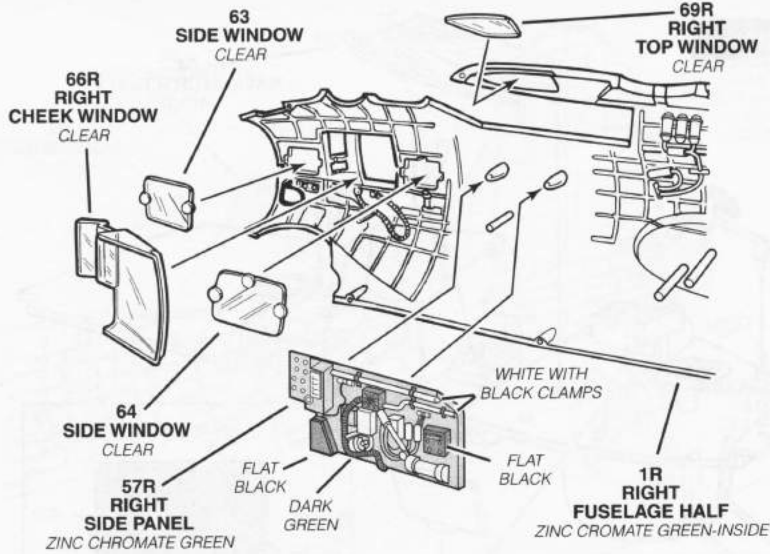

BEFORE PROCEEDING TO STEP 7, DETERMINE WHICH LEFT (PORT) SIDE FUSELAGE HALF TO USE, CLEAR FUSELAGE HALF OR SOLID PLASTIC FUSELAGE HALF

7

COCKPIT / BOMBARDIER ASSEMBLY

ASSEMBLED COCKPIT TO FUSELAGE

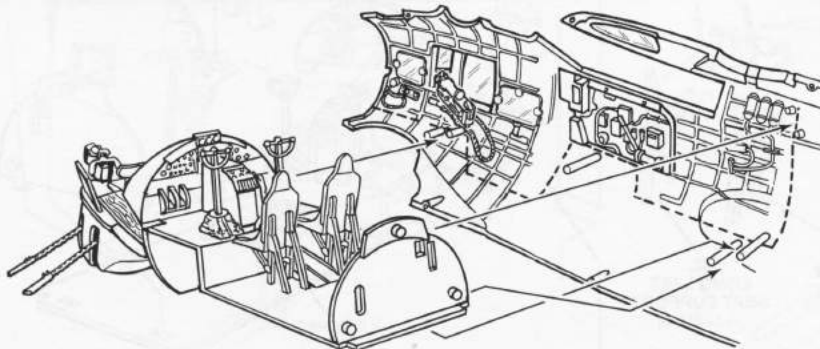

ASSEMBLED BOMBARDIER IN PLACE

8

WAIST GUN AREA ASSEMBLY

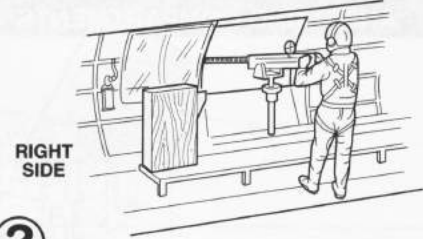
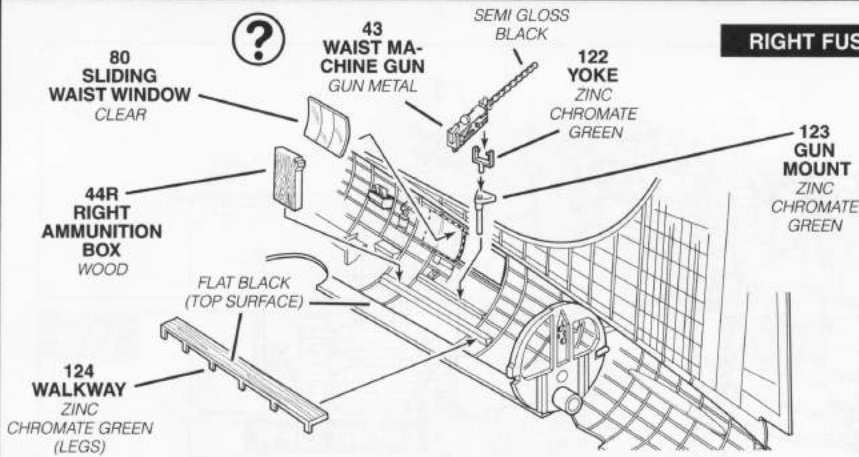

STANDING WAIST GUNNER IN PLACE

IF YOU CHOOSE NOT TO USE THE WAIST MACHINE GUNS, WINDOWS AND GUNNERS IN THIS STEP, THEN SEE STEP 17

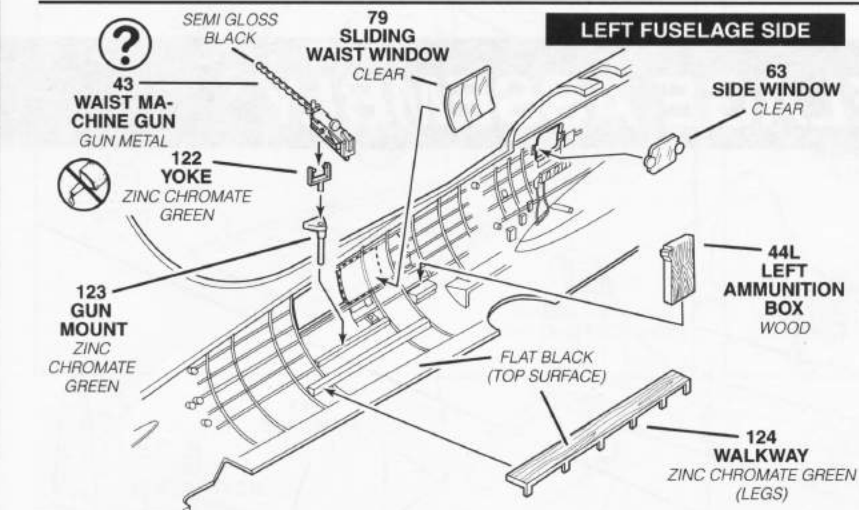

SQUATTING WAIST GUNNER IN PLACE

9

BOMB RACK ASSEMBLY

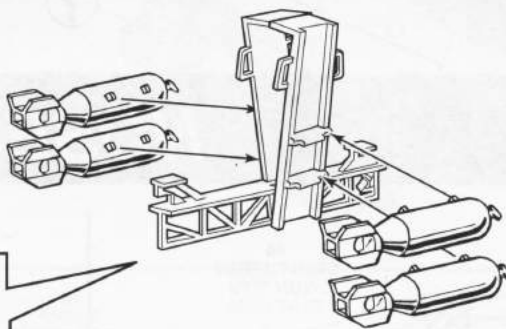
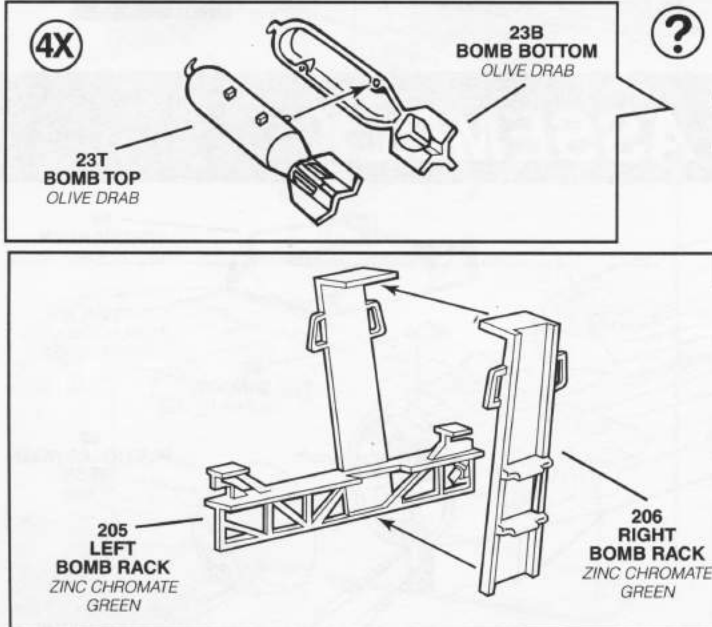

FRONT VIEW OF COMPLETED BOMB RACK WITH BOMBS IN PLACE.

IF YOU CHOOSE NOT TO USE THE BOMBS IN THIS STEP, THEY CAN BE USED IN STEP 22 ON THE BOMB CART.

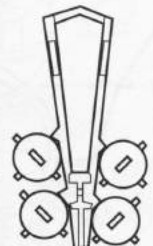

9

BOMB RACK ASSEMBLY FINAL

BOMB RACK BETWEEN COCKPIT AND RADIO COMPARTMENTS

BOMB RACK TO RIGHT FUSELAGE

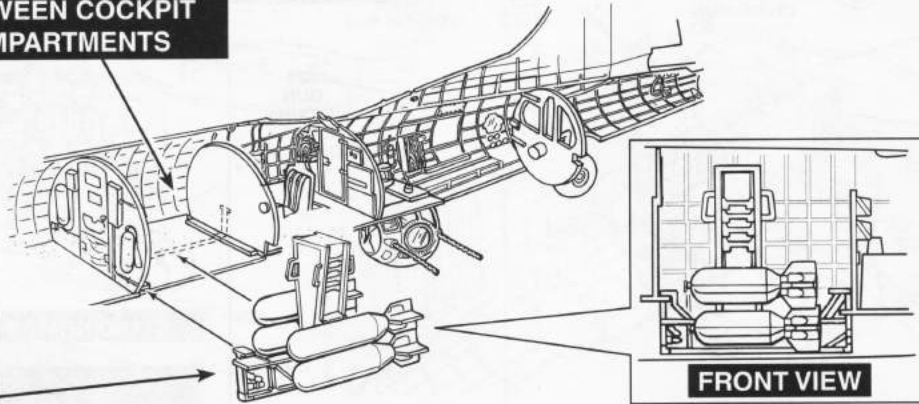

10

FUSELAGE ASSEMBLY

?

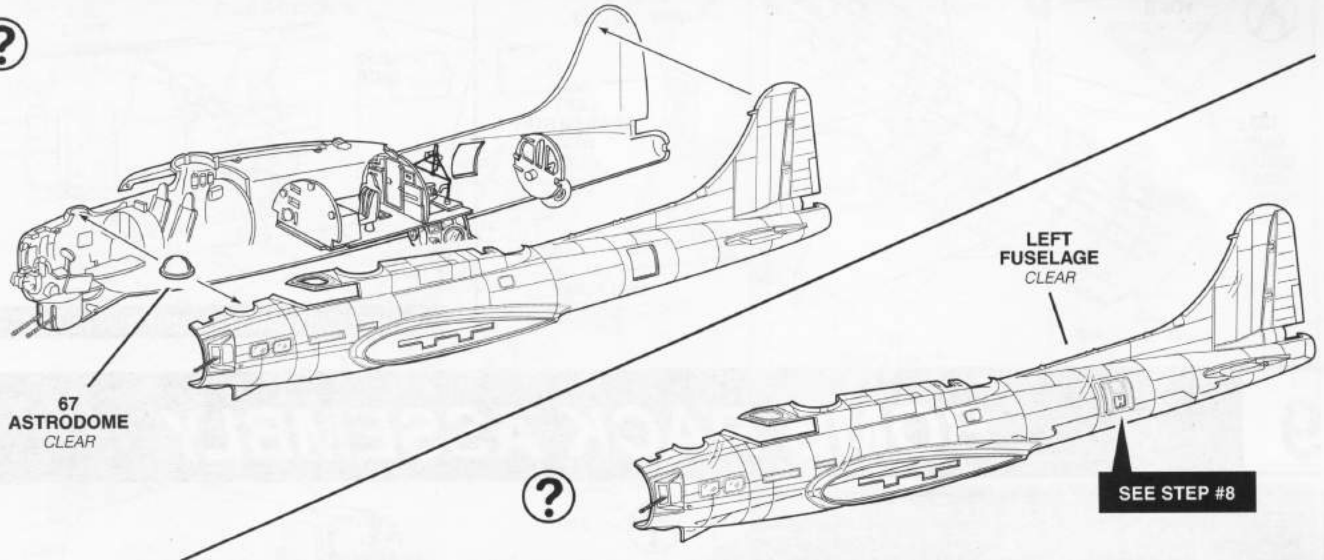

67
ASTRODOME
CLEAR

LEFT
FUSELAGE
CLEAR

SEE STEP #8

?

11

NOSE ASSEMBLY

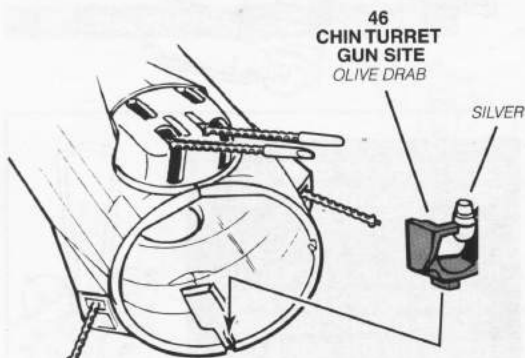

46
CHIN TURRET
GUN SITE
OLIVE DRAB

SILVER

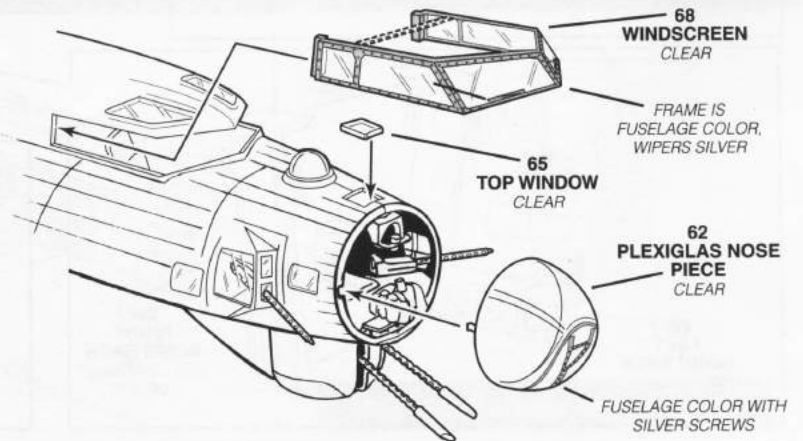

68
WINDSCREEN
CLEAR

FRAME IS
FUSELAGE COLOR,
WIPERS SILVER

65
TOP WINDOW
CLEAR

62
PLEXIGLAS NOSE
PIECE
CLEAR

FUSELAGE COLOR WITH
SILVER SCREWS

12

LANDING GEAR / WING ASSEMBLY

(2X)

32L
LEFT
MAIN WHEEL
FLAT BLACK

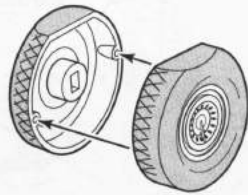

32R
RIGHT
MAIN WHEEL
FLAT BLACK

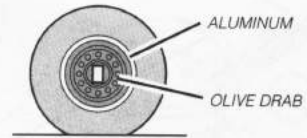

ALUMINUM
OLIVE DRAB

LEFT

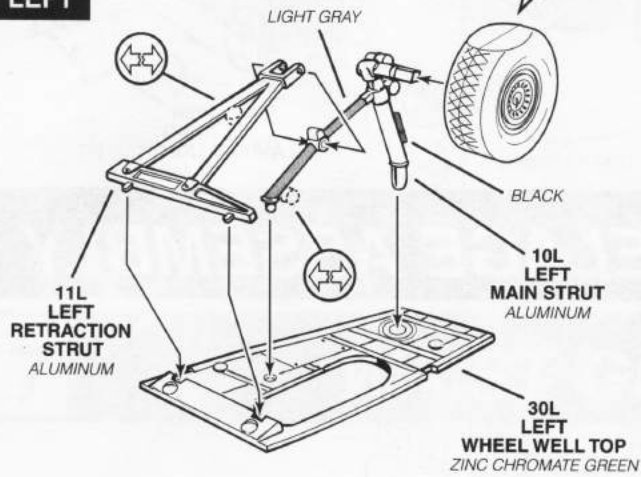

RIGHT

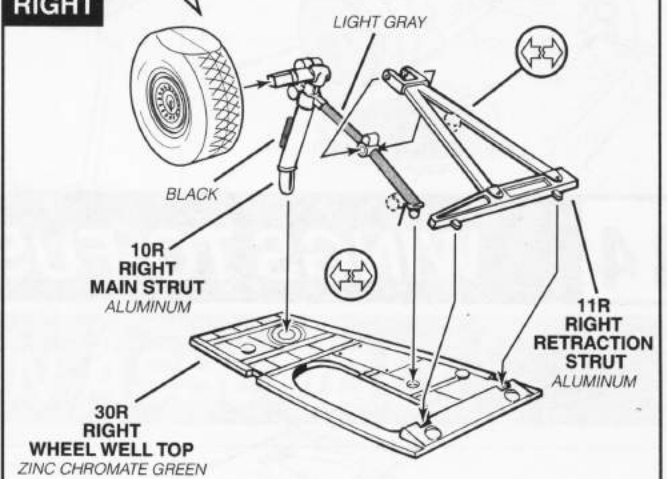

3L
LEFT
WING BOTTOM

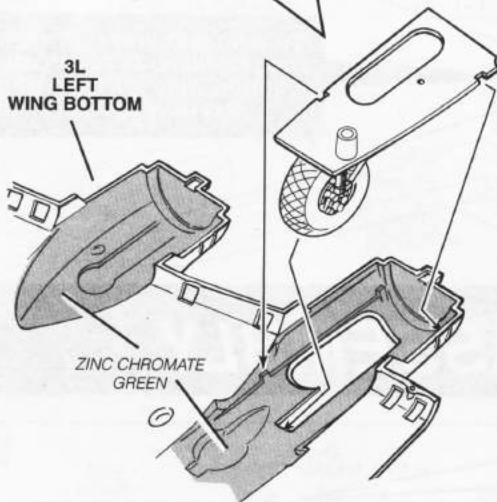

3R
RIGHT
WING BOTTOM

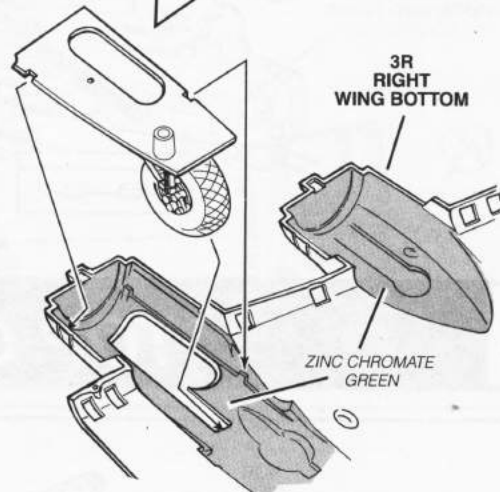

4L
LEFT
WING TOP

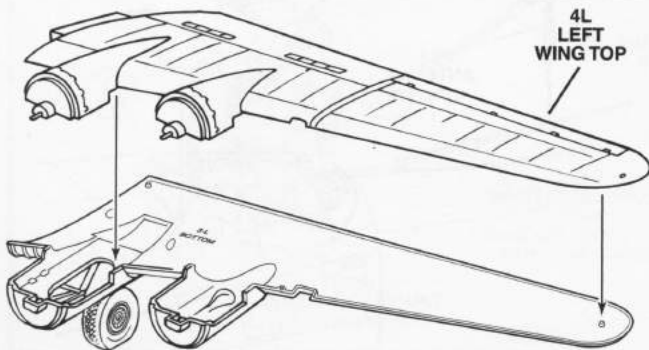

4R
RIGHT
WING TOP

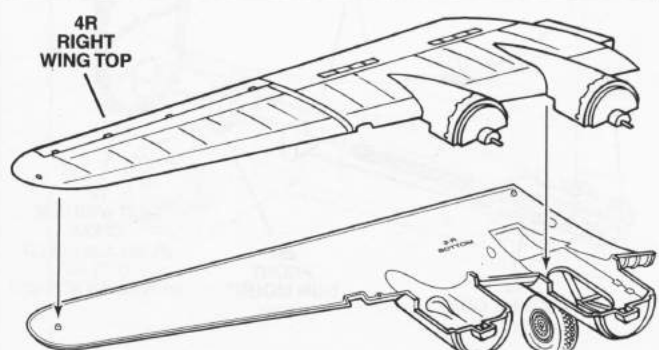

13

EXHAUST PIPE ASSEMBLY

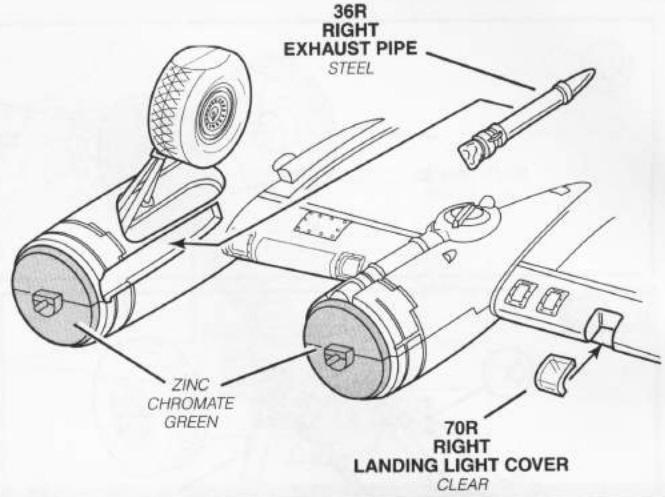
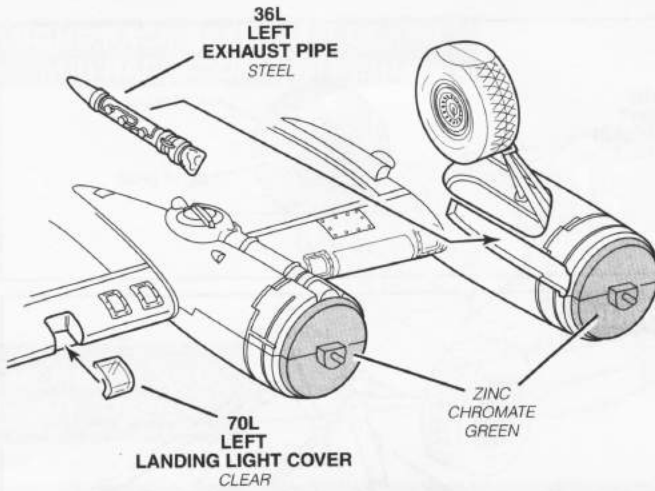

14

WINGS TO FUSELAGE ASSEMBLY

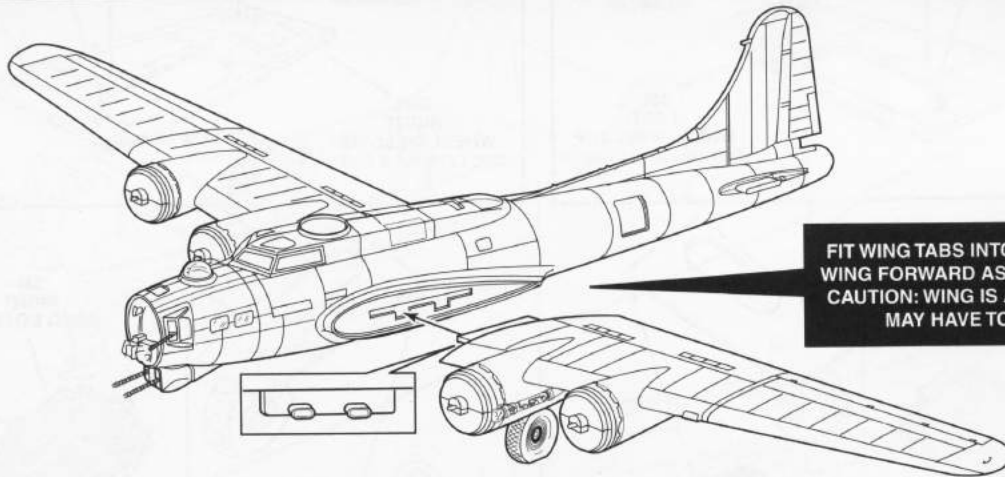

15

TOP GUN ASSEMBLY

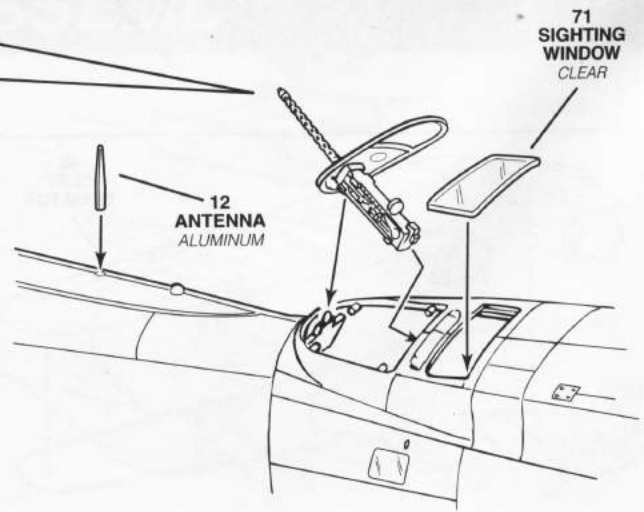
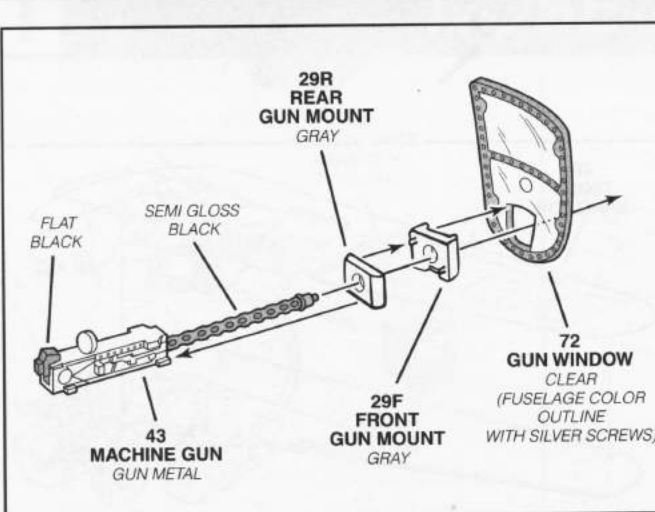

16

TOP TURRET GUN ASSEMBLY

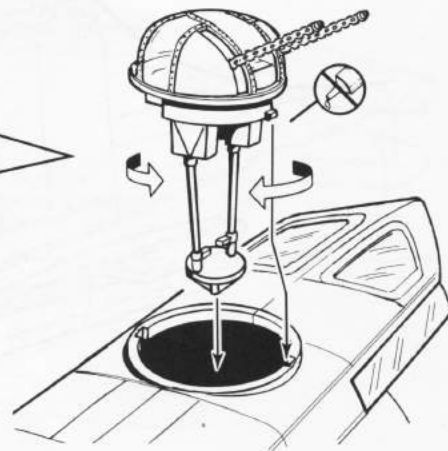
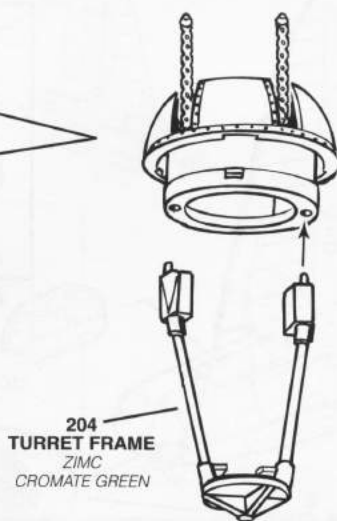
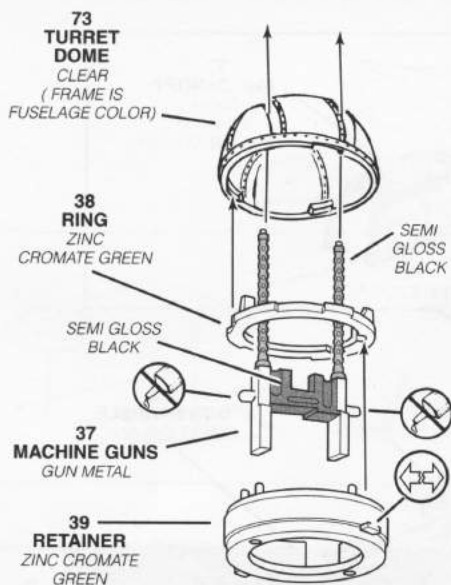

17

WAIST GUN ASSEMBLY

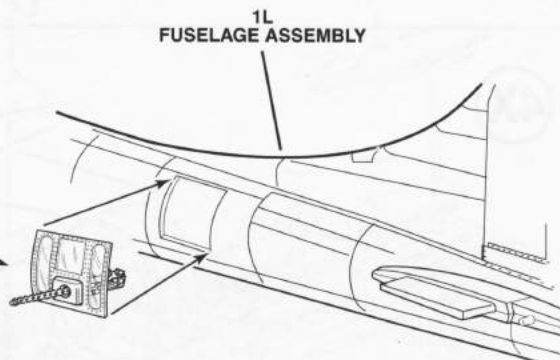
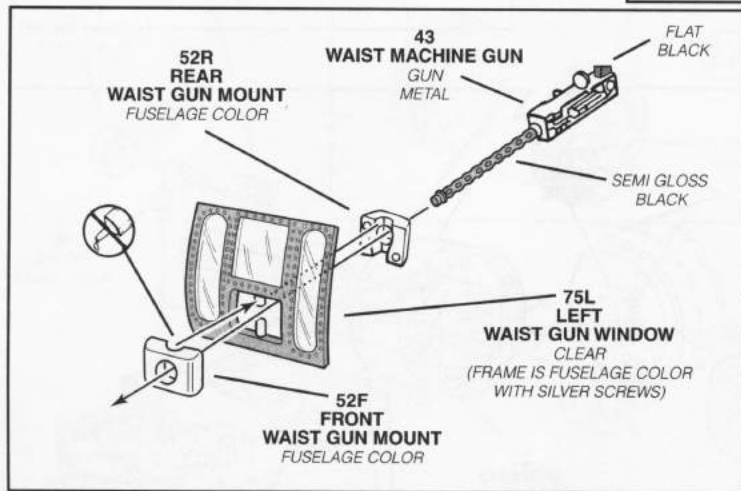
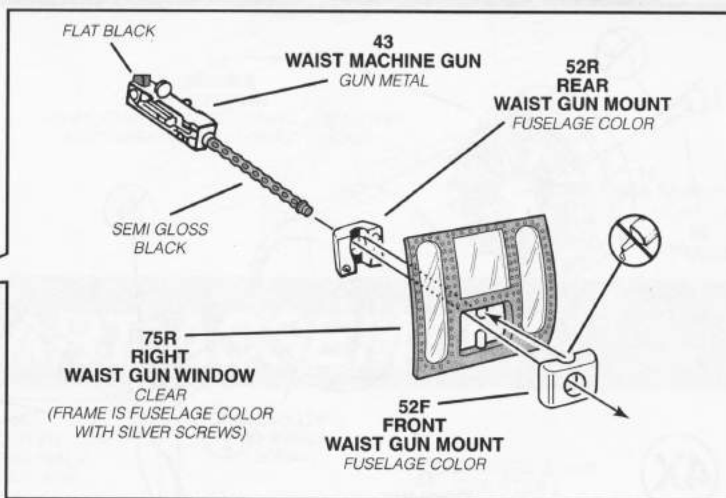
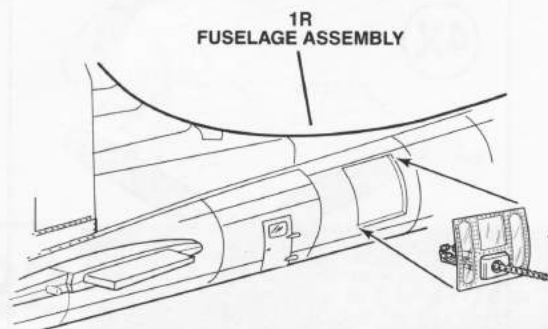

18

TAIL GUN ASSEMBLY

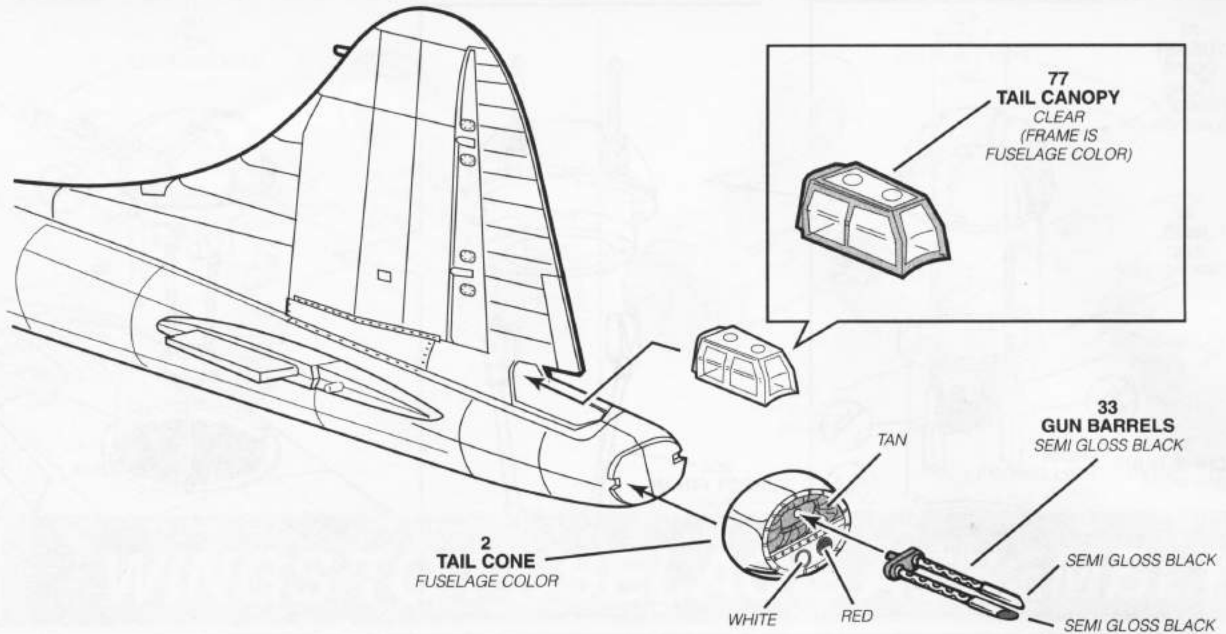

19

PROPELLER / ENGINE ASSEMBLY

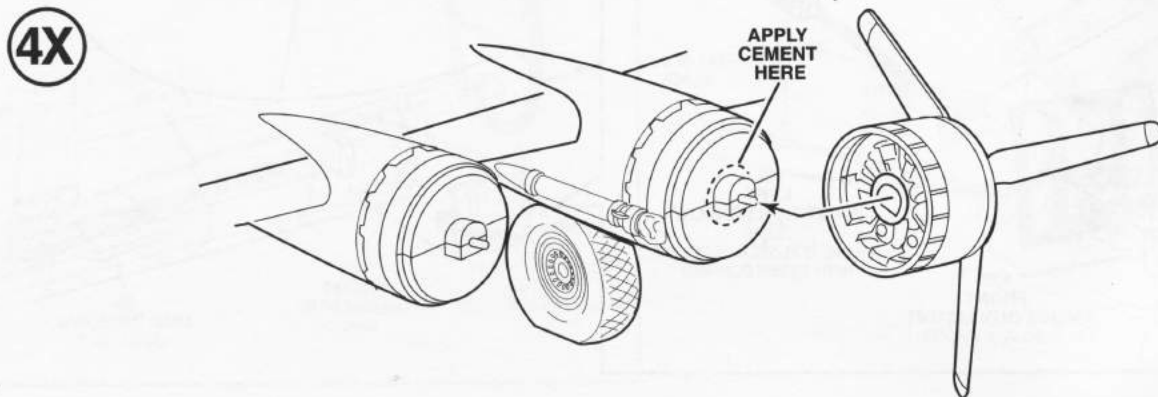
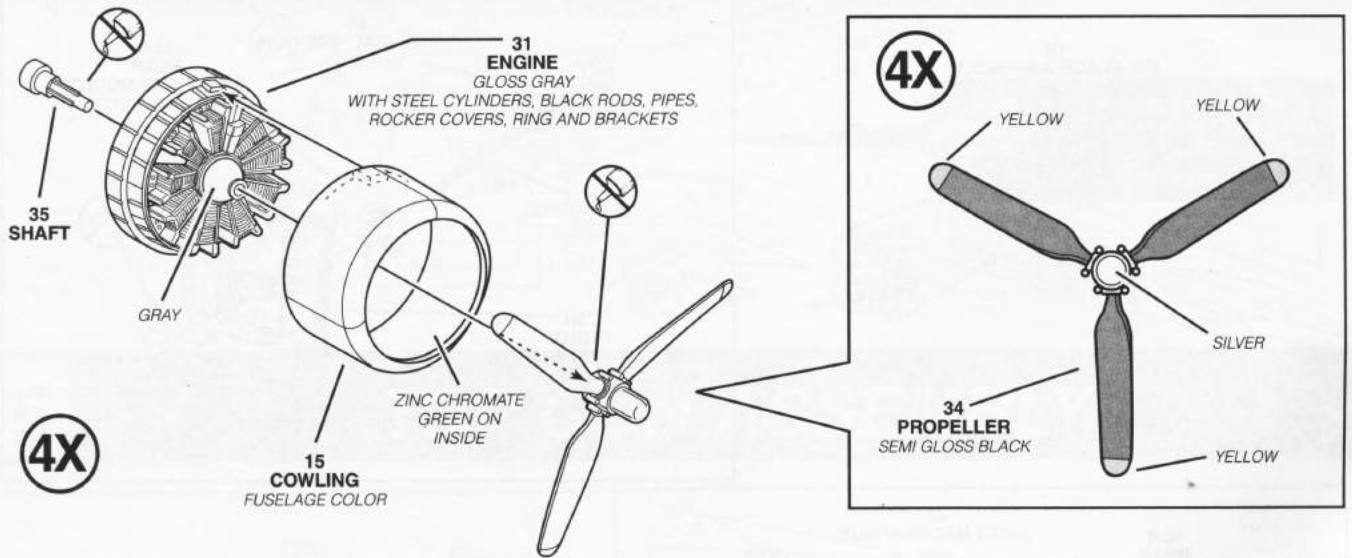

20

STABLIZER ASSEMBLY

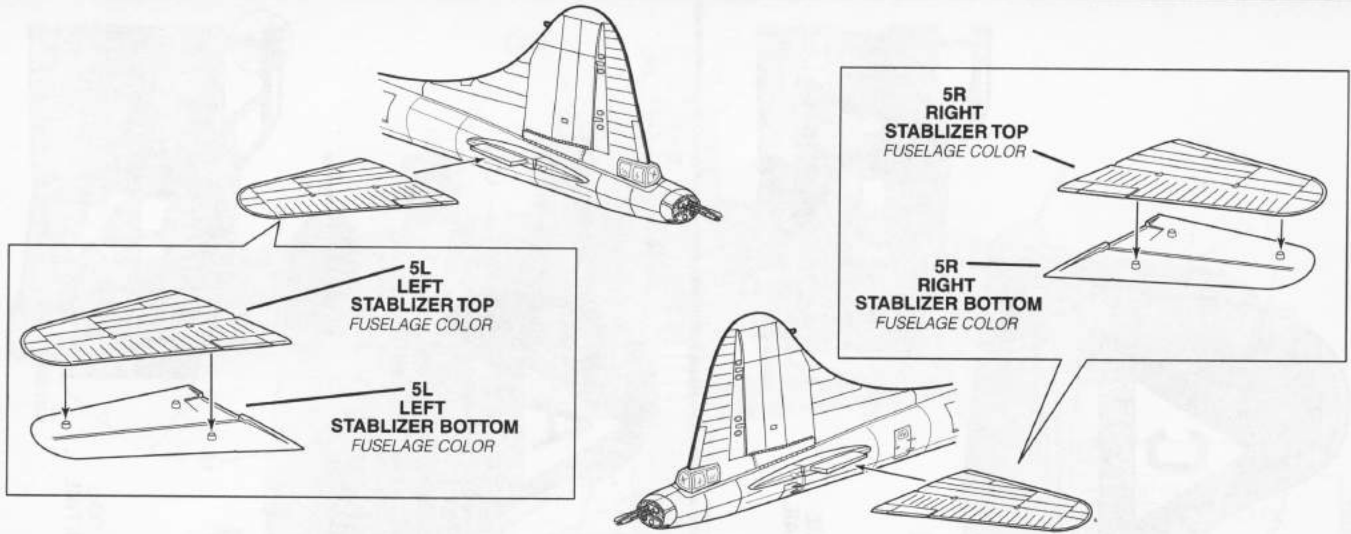

21

FINAL ASSEMBLY

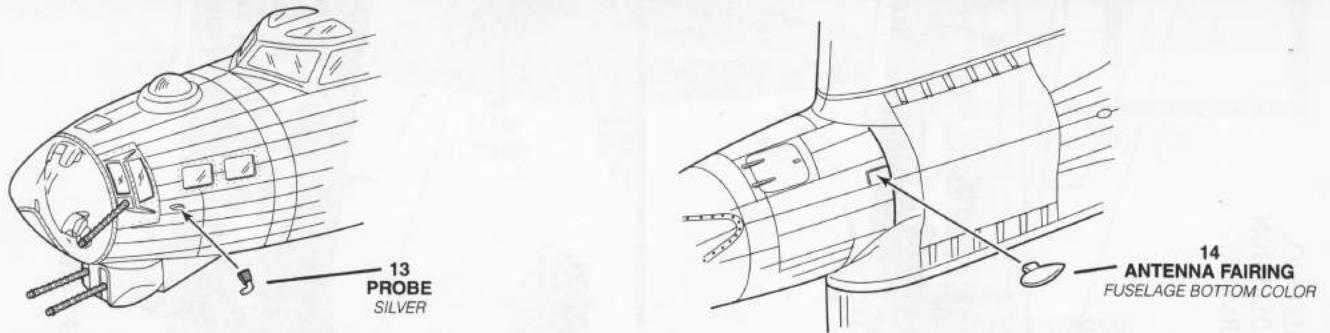

22

BOMB CART ASSEMBLY

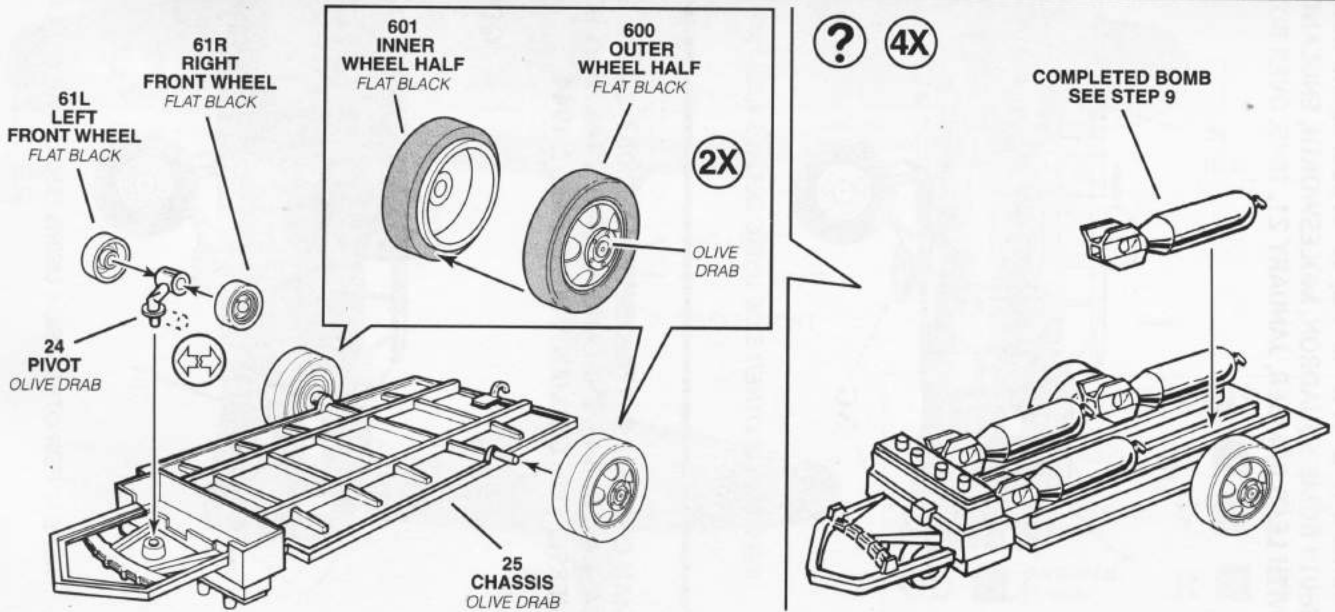

SCORCHY II, B-17G-40-B0, 42-97058, 303RD BOMB GROUP (HEAVY),
360TH BOMB SQUADRON, MOLESWORTH, ENGLAND. LOST IN COLLISION
WITH LEAD BOMBER, JANUARY 21, 1945, OVER ROTTWELL, GERMANY.

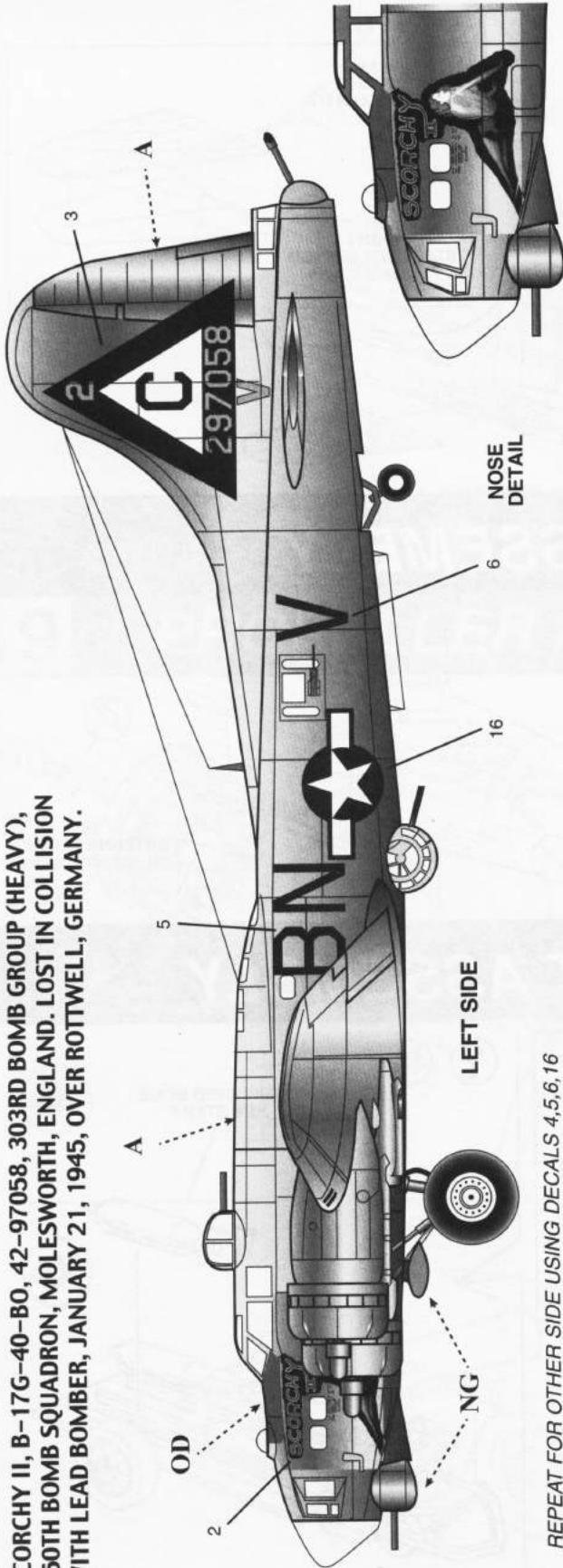

REPEAT FOR OTHER SIDE USING DECALS 4,5,6,16

MAN O WAR II, B-17G-25-VE, 42-38083, 332ND BOMB SQUADRON,
BASINGBOURNE, ENGLAND, MARCH, 1944. SHOT DOWN OVER
MERSEBERG, GERMANY, NOVEMBER 2, 1944.

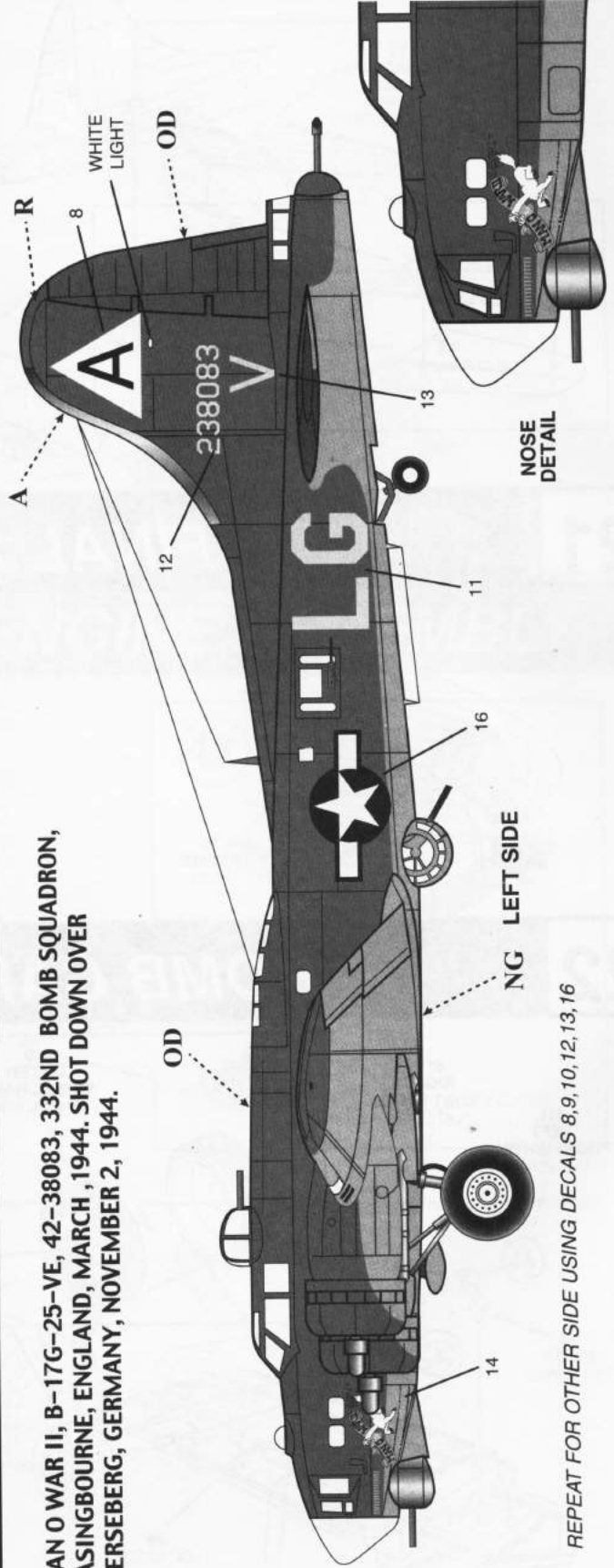

REPEAT FOR OTHER SIDE USING DECALS 8,9,10,12,13,16

DECAL PLACEMENT



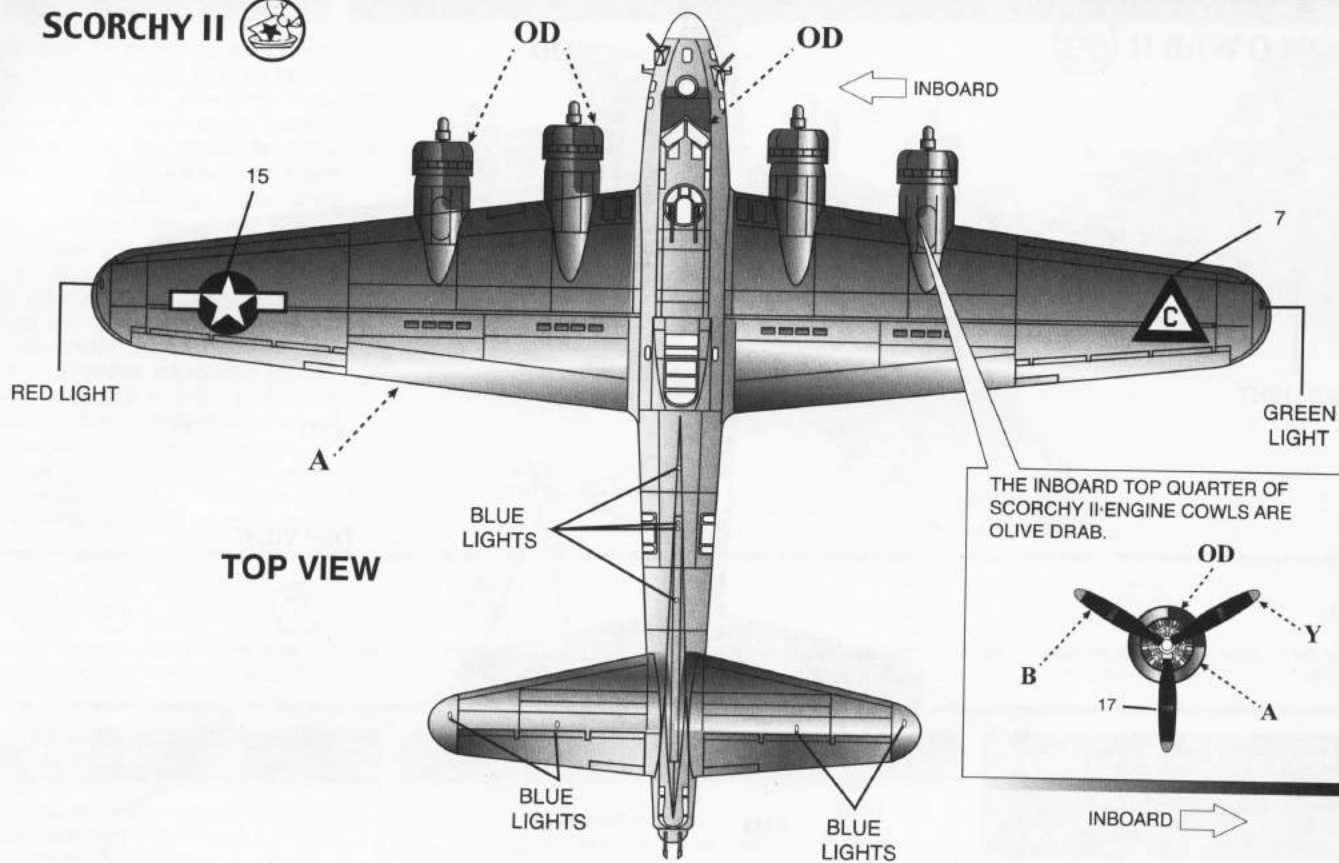

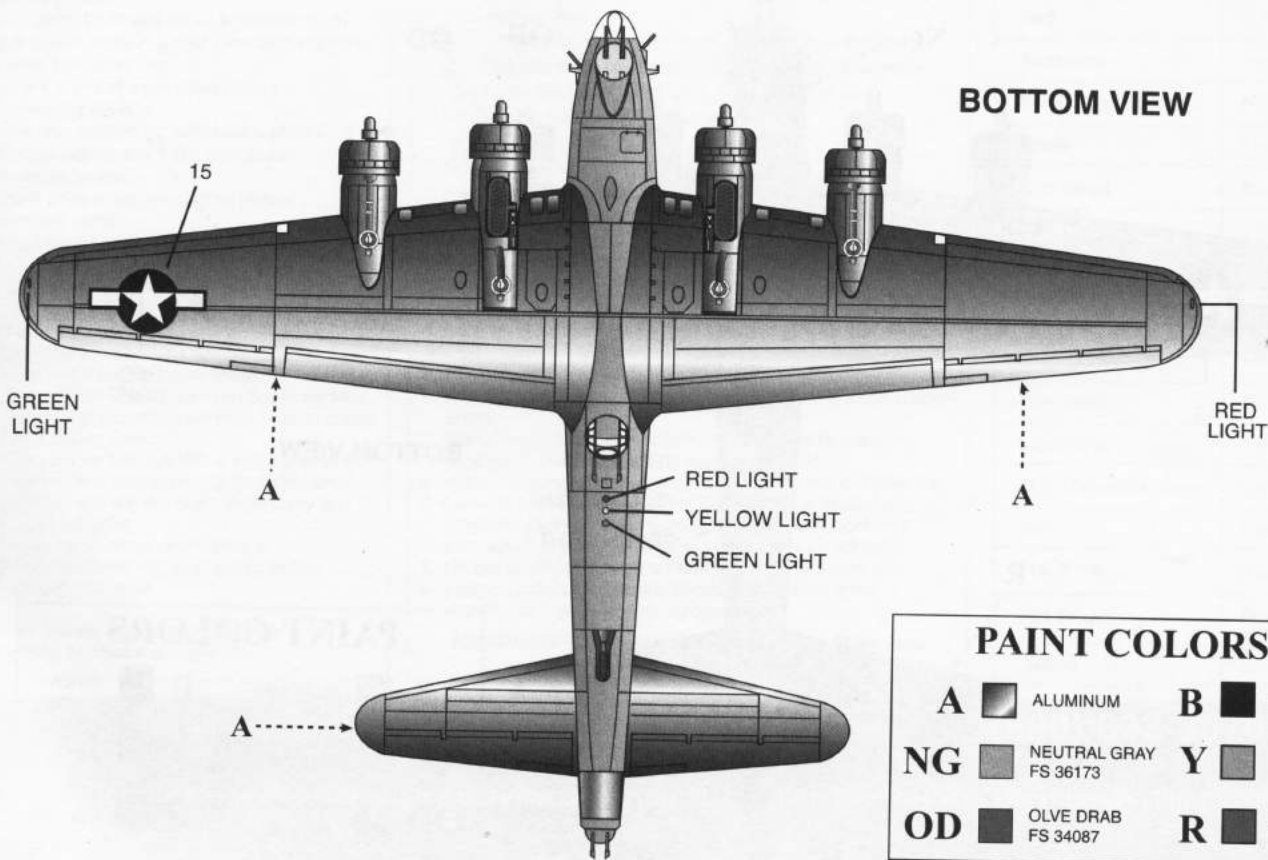

SCORCHY II 



BOTTOM VIEW



PAINT COLORS

A	 ALUMINUM	B	 BLACK
NG	 NEUTRAL GRAY FS 36173	Y	 YELLOW FS 13507
OD	 OLIVE DRAB FS 34087	R	 RED FS 11140

MAN O WAR II 

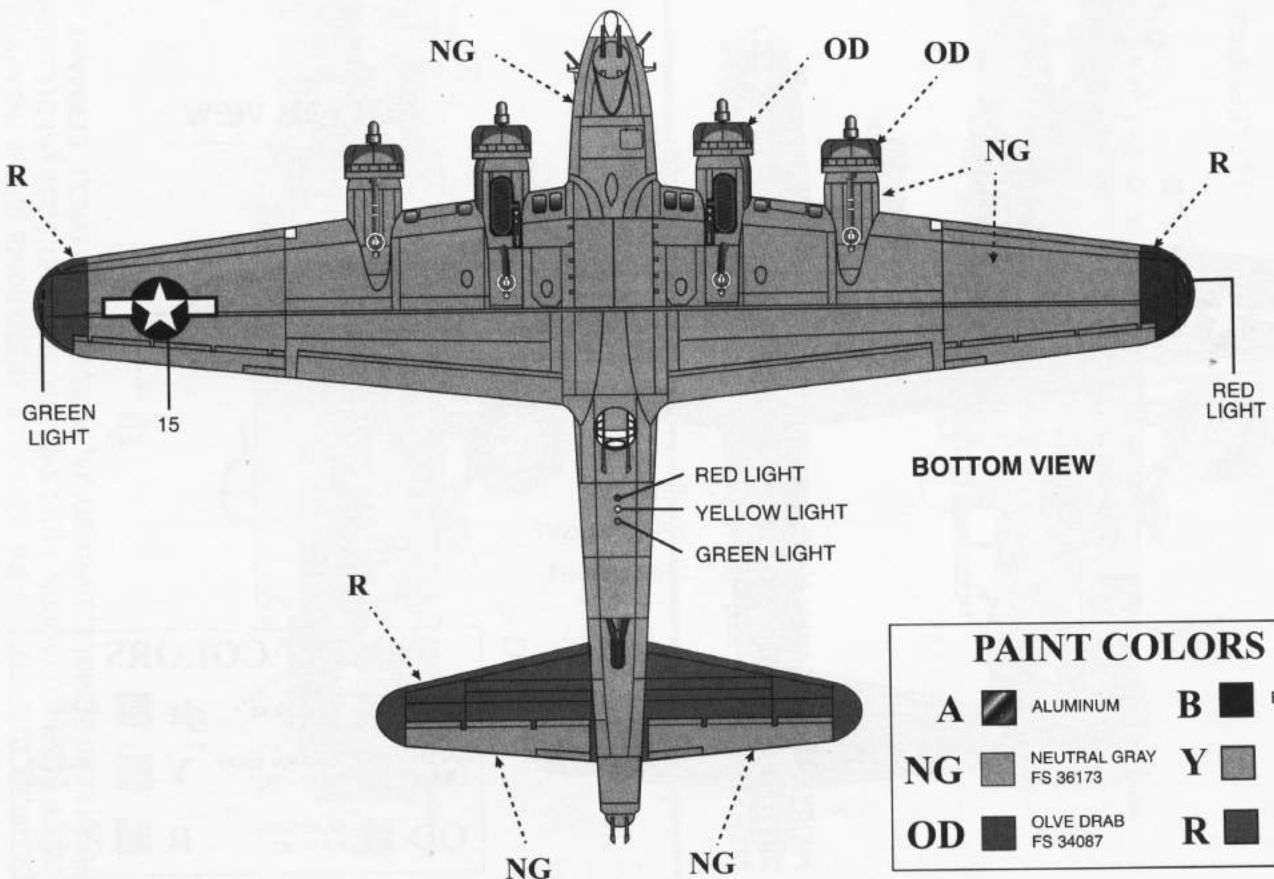
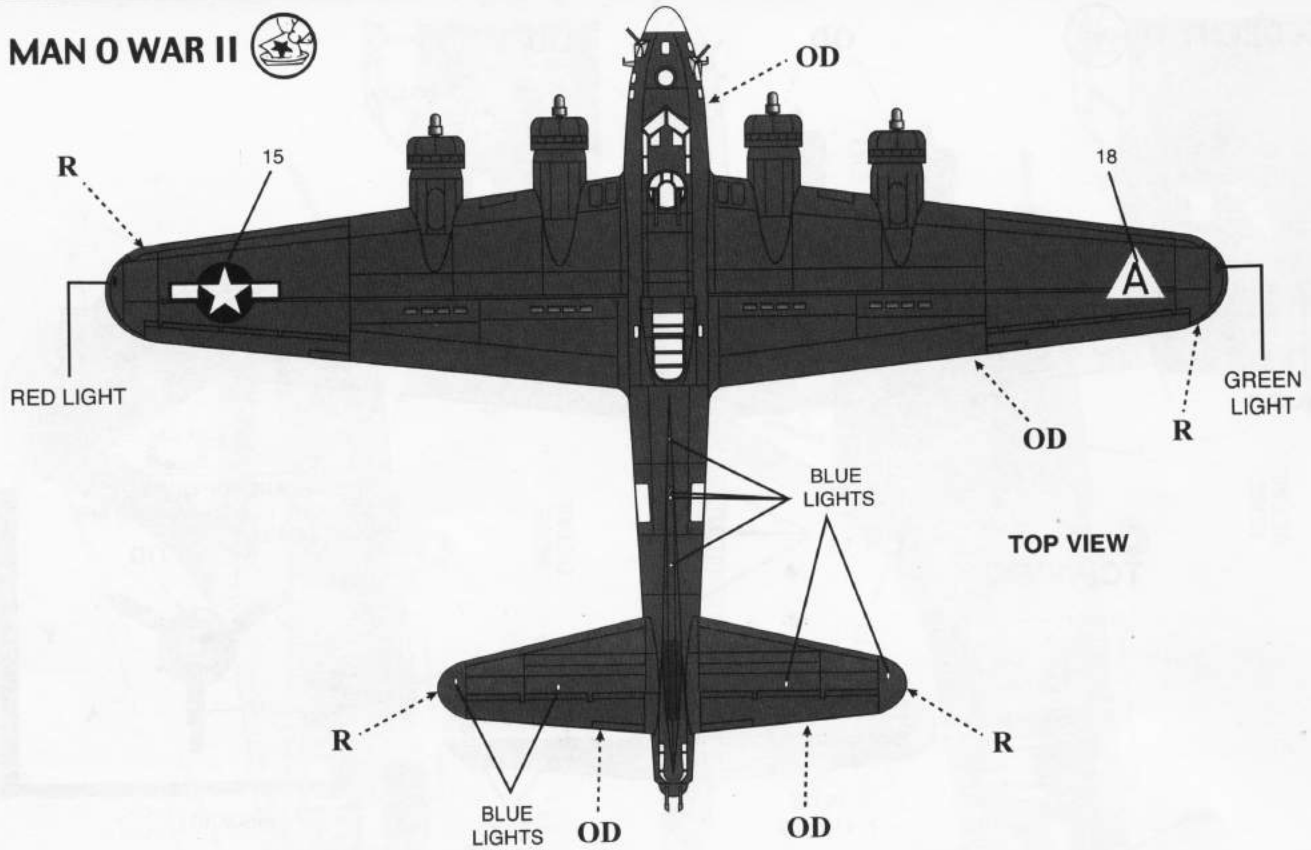

PAINT COLORS					
A		ALUMINUM	B		BLACK
NG		NEUTRAL GRAY FS 36173	Y		YELLOW FS 13507
OD		OLIVE DRAB FS 34087	R		RED FS11140

ST ST ST ST
ST ST 17 ST ST
ST ST ST ST

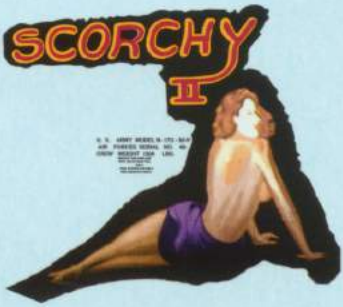

238083 238083

