



Warrior MCV mit Zusatzpanzerung

03144-0389

© 2005 BY REVELL GmbH & CO. KG

PRINTED IN GERMANY



Warrior MCV mit Zusatzpanzerung

Die Serienfertigung des für die britische Armee entwickelten Schützenpanzers Warrior lief 1986 bei GKN Sankey an. Das erste Fahrzeug, offiziell als FV 510 Warrior, Mechanised Combat Vehicle (MCV) bezeichnet, wurde im Mai 1987 an das 1st Battalion Grenadier Guards übergeben. Die Aluminiumpanzerung des Warrior bietet Schutz gegen Geschosse bis zu einem Kaliber von 14,5 mm sowie Artilleriesplittern. Der hintere Kampfraum bietet bis zu sieben Soldaten Platz und eine große rechts angeschlagene Tür im Fahrzeugheck ermöglicht ein zügiges Absitzen. Als Hauptbewaffnung dient eine in dem um 360 Grad drehbaren Turm untergebrachte 30 mm L21A1 Rarden-Maschinenkanone mit einer Kadenz von ca. 80 Schuss/min. Die Munition wird in Drei-Schuss-Clips manuell zugeführt, der Auswurf der leeren Hülsen erfolgt extern. Als Sekundärbewaffnung ist ein 7,62 mm MG (L94A1 chaingun) vorhanden, das links in der Kanonenblende koaxial zur Hauptwaffe eingebaut ist. Der im Bug rechts vom Fahrer eingebaute V8-Zylinder Perkins Engines Condor CV8 TCA Dieselmotor mit 550 PS Leistung ermöglicht dem Warrior, bei einem Gefechts-gewicht von 25.700 kg, eine Höchstgeschwindigkeit von 75 km/h.

Warrior MCV with add-on armour

The Warrior mechanised combat vehicle developed for the British Army went into production at GKN Sankey in 1986. The first vehicle, officially designated the FV510 Warrior Mechanised Combat Vehicle (MCV), was delivered to the 1st Battalion the Grenadier Guards in May 1987. The aluminium armour of the Warrior offers protection against shells up to a calibre of 14.5 mm as well as splinters. There is room for up to seven soldiers in the rear troop compartment and a large right-hung door in the rear to enable rapid debussing. The main armament is a 30 mm L21A1 Rarden cannon, firing at a rate of approx. 80 rounds/minute, which is located in the turret that traverses through 360 degrees. The ammunition is fed manually in three clips, with the empty cases ejected externally. As secondary armament it has a 7.62 mm MG (L94A2 chain gun) mounted coaxial to the main gun and to the left in the same port. The 550 hp Perkins Condor CV8 TCA V-8 diesel engine, mounted in the front to the right of the driver, gives the Warrior a top speed of 75 km/h with a combat weight of 25,700 kg.

Form hergestellt und im Eigentum von Revell GmbH & Co. KG/Revell Monogram Inc. Widerrechtliche Nachahmungen werden gerichtlich verfolgt.

Ce produit est propriété de la société Revell GmbH & Co. KG/Revell Monogram Inc. Toute utilisation ou duplication frauduleuse fera l'objet de poursuites en justice.

Modelado y en propiedad de Revell GmbH & Co. KG/Revell Monogram Inc. Imitaciones ilícitas serán perseguidas por la ley.

Forma prodotta dalla Revell GmbH & Co. KG/Revell Monogram Inc. e di proprietà della stessa impresa, la quale procederà legalmente contro ogni imitazione abusiva.

Malli on Revell GmbH & Co. KG/Revell Monogram Inc. valmistama ja omaisuutta. Laittoaman kopiointiin tullaan puuttamaan oikeudellisiin toimin.

Formen er produsert og eies av Revell GmbH & Co. KG/Revell Monogram Inc. Etterligning uten tillatelse vil bli gjenstand for rettslig forfølgelse.

Produkcja i prawa własności firmy Revell GmbH & Co. KG/Revell Monogram Inc. Nielegalne podrobienie jest zabronione pod odpowiedzialnością sądową.

Model, Revell GmbH & Co. KG/Revell Monogram Inc. firmasının mülkiyeti altında imal edilmiştir. Kanuna aykırı taklitler mahkemeye takip edilecektir.

A forma előállítója és a tulajdonos jogait károsan a Revell GmbH & Co. KG/Revell Monogram Inc. A jogellenes utánzatokat és hamisítványokat bírósággal üldözik, j. üldöz.

Mould manufactured by and property of Revell GmbH & Co. KG/Revell Monogram Inc. Illegal imitations are subject to prosecution.

Vorm vervaardigd door en eigendom van Revell GmbH & Co. KG/Revell Monogram Inc. Onrechtmatige nabootsing worden gerechtelijk vervolgd.

Formas produzidas e de propriedade da Revell GmbH & Co. KG/Revell Monogram Inc. Cópias não autorizadas serão processadas juridicamente como determinado na lei.

Modellen tilverkad av och tillhör Revell GmbH & Co. KG/Revell Monogram Inc. All kopiering beivras enligt lagen om upphovsrätt.

Formen er fremstillet af Revell GmbH & Co. KG/Revell Monogram Inc. som også har ejendomsret. Lovstridige efterligninger sagsages.

Μοδελιζ αποσκευασενα και ειναι της ιδιοτητας της Revell GmbH & Co. KG/Revell Monogram Inc. Οι παρανομες μιμησεις θα καταδικασονται δικαστικως.

Tvar byl vytvořen firmou Revell GmbH & Co. KG/Revell Monogram Inc. a je jejím vlastnictvím. Proti nezákonným napodobením se bude postupovat soudní cestou.

Forma je proizvedene in je vlasništvo Revell GmbH & Co. KG/Revell Monogram Inc. Neovlaštene kopije bodo pravno kažnjene.

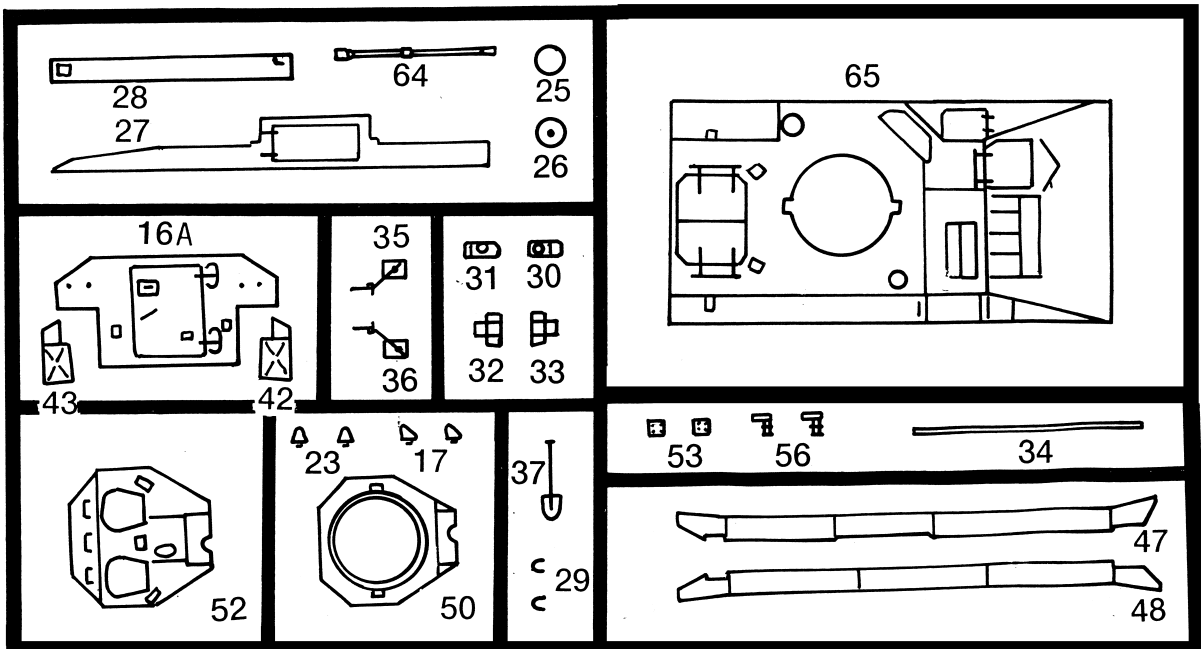
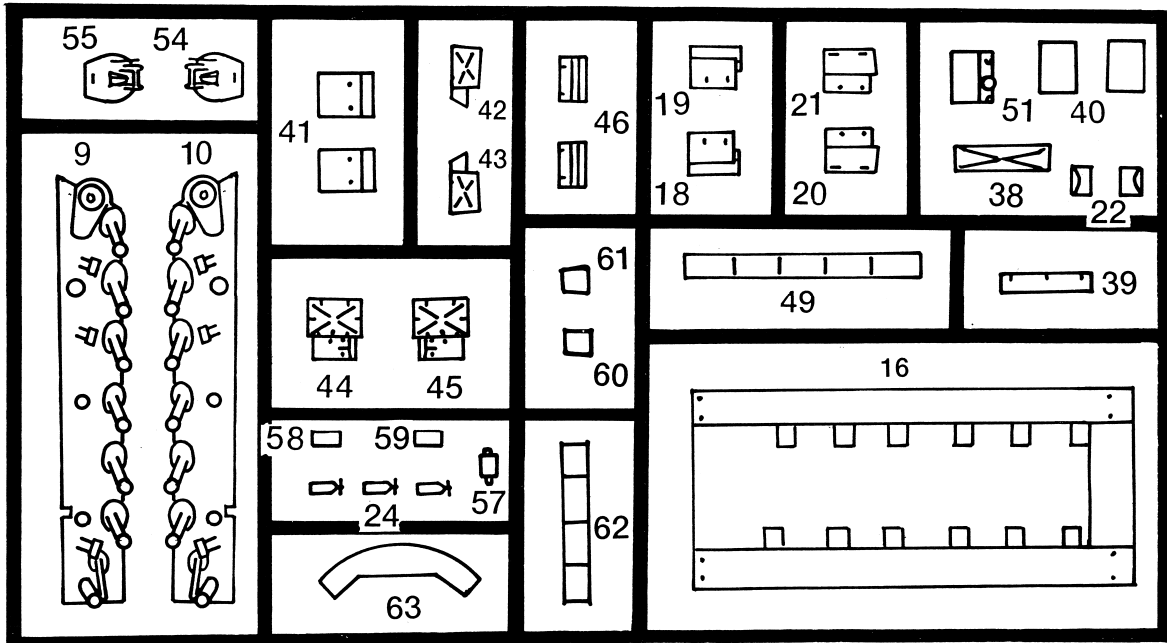
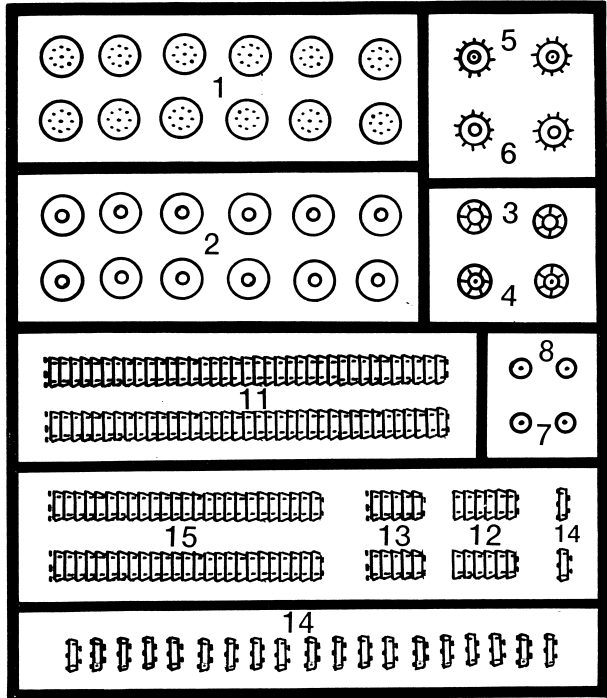
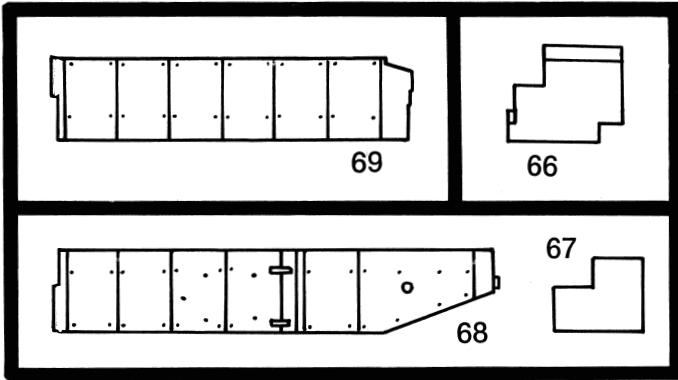

1 

12X

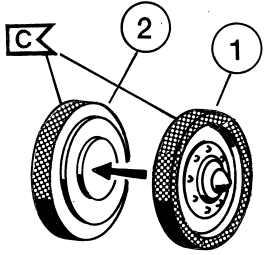

2 

2X

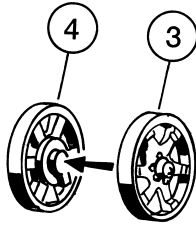

5 

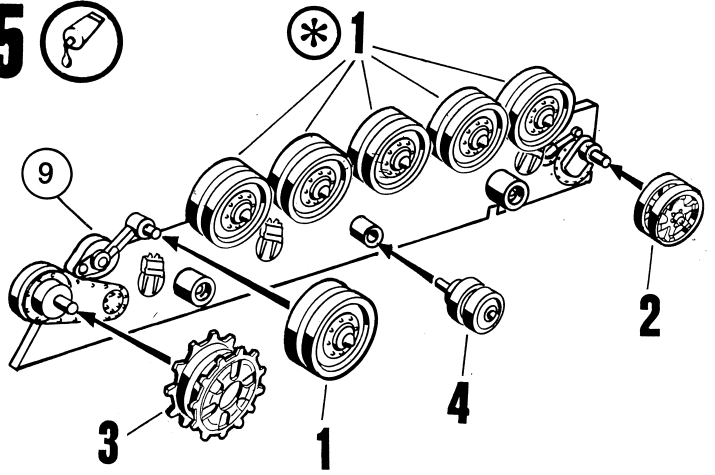

3 

2X

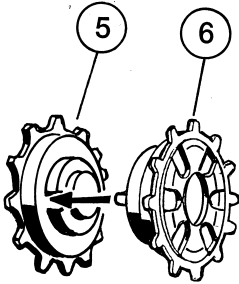

4 

2X

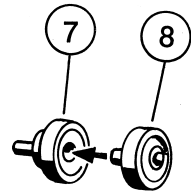

6 

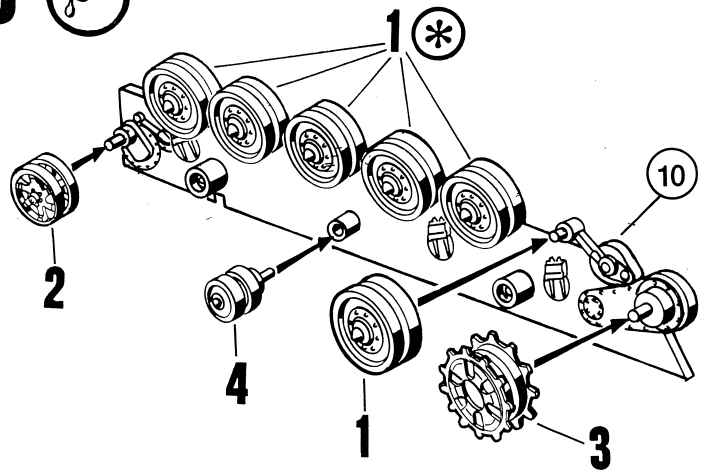

7  

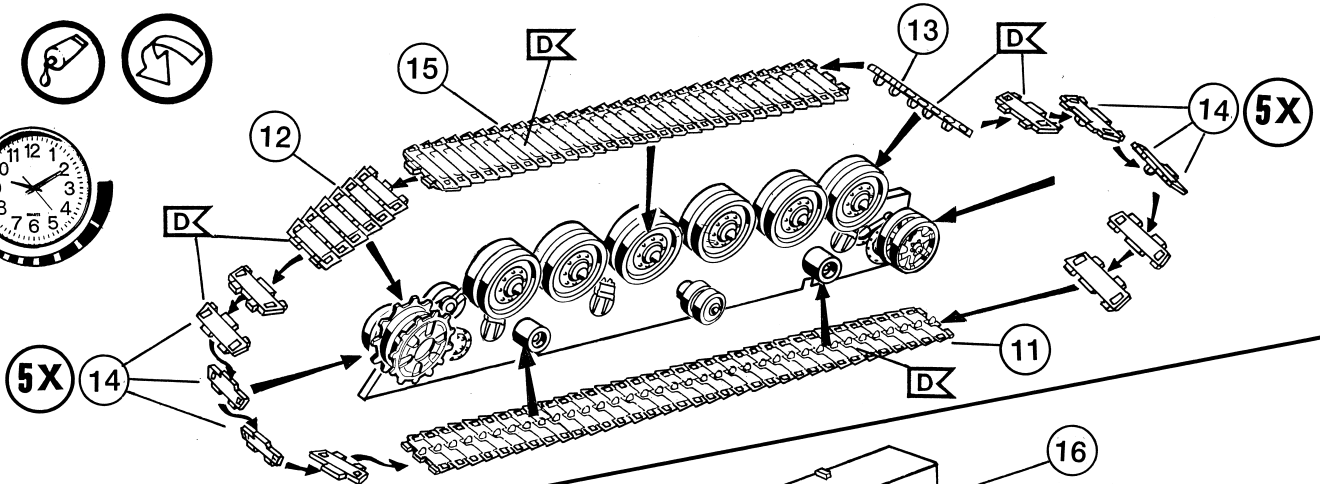

8 

***7**

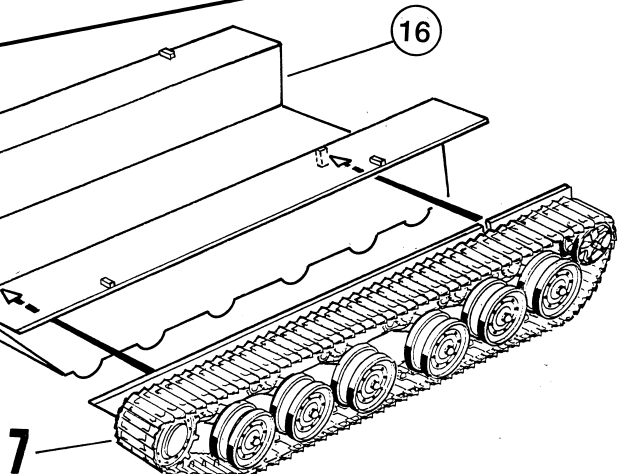

9 

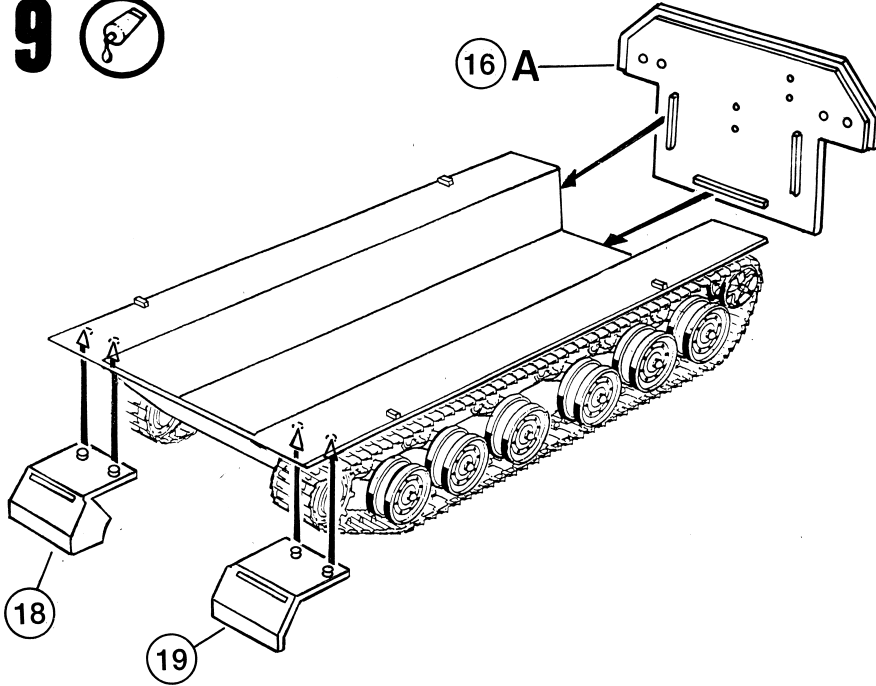

10 

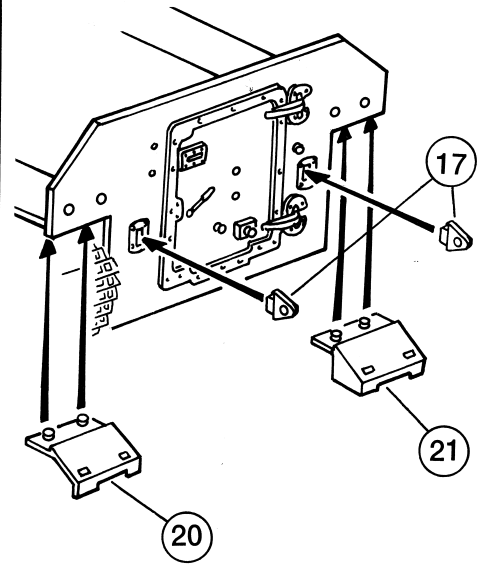

11 

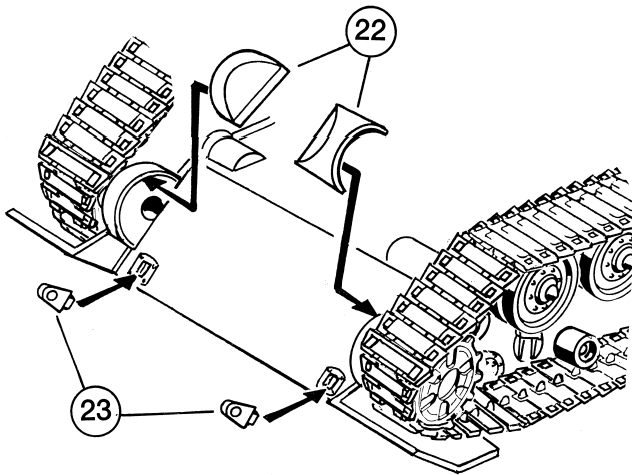

12 

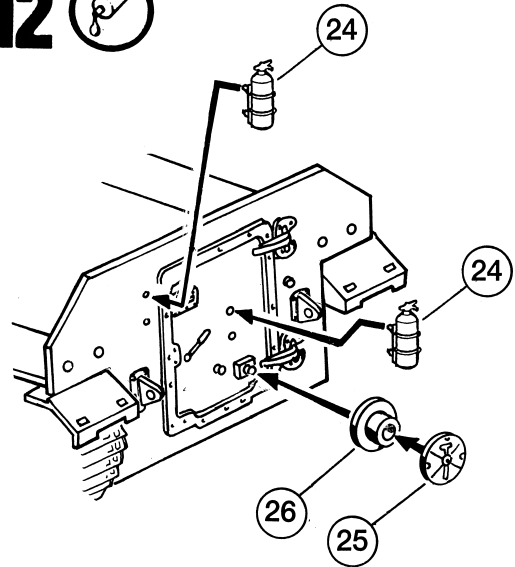

13 

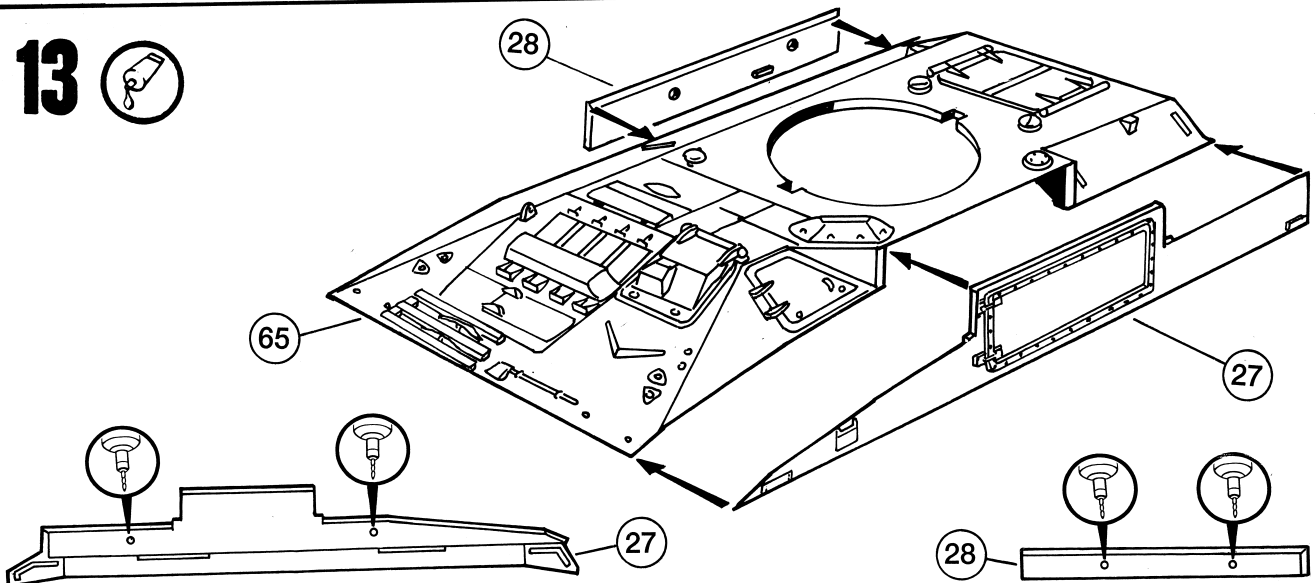

14  

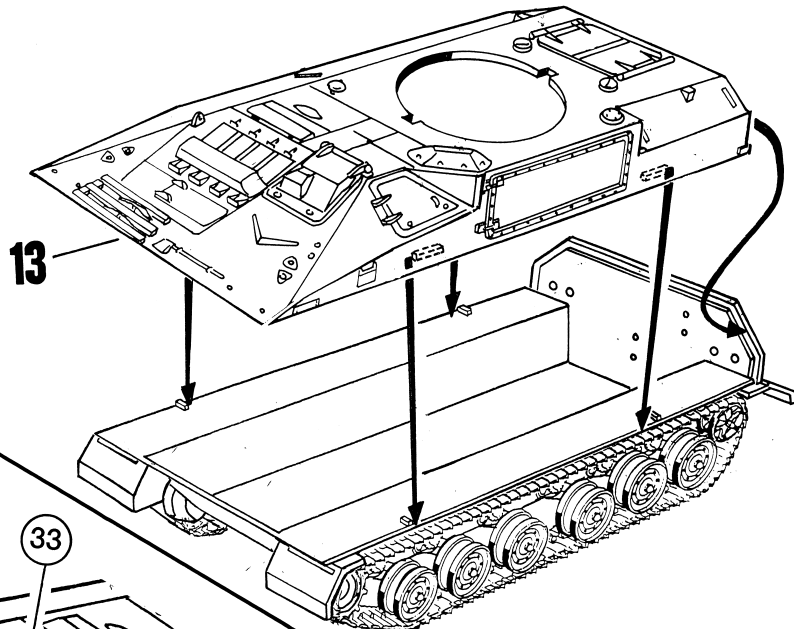

15 

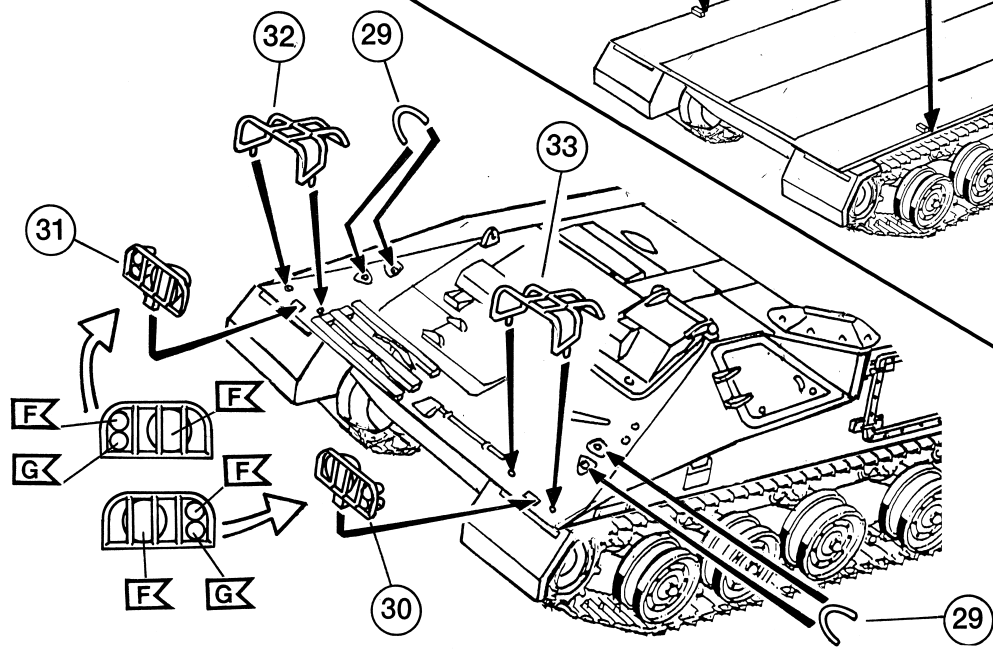

16 

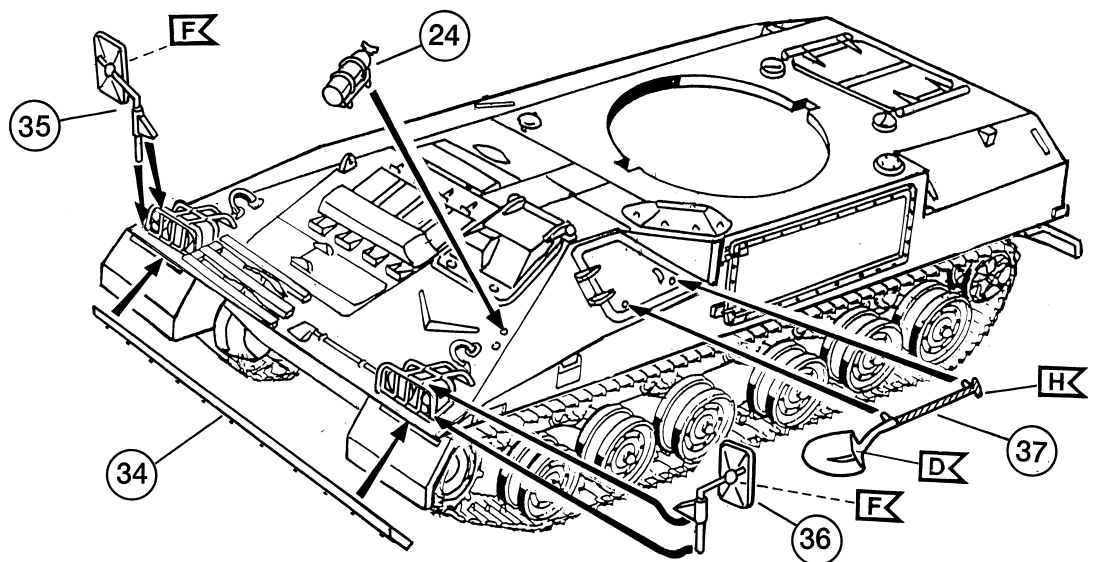

17 

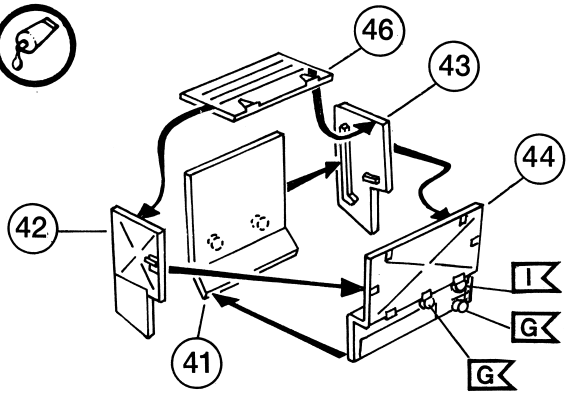

18 

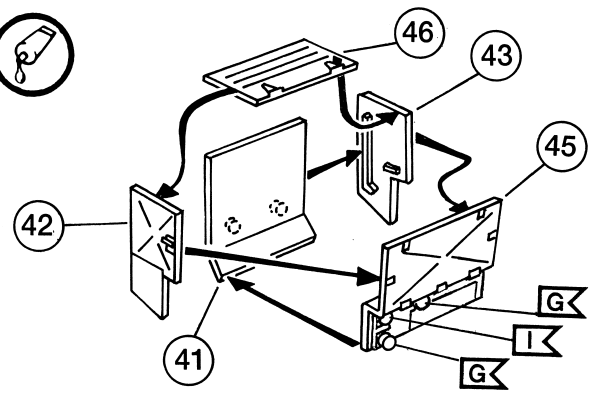

19 

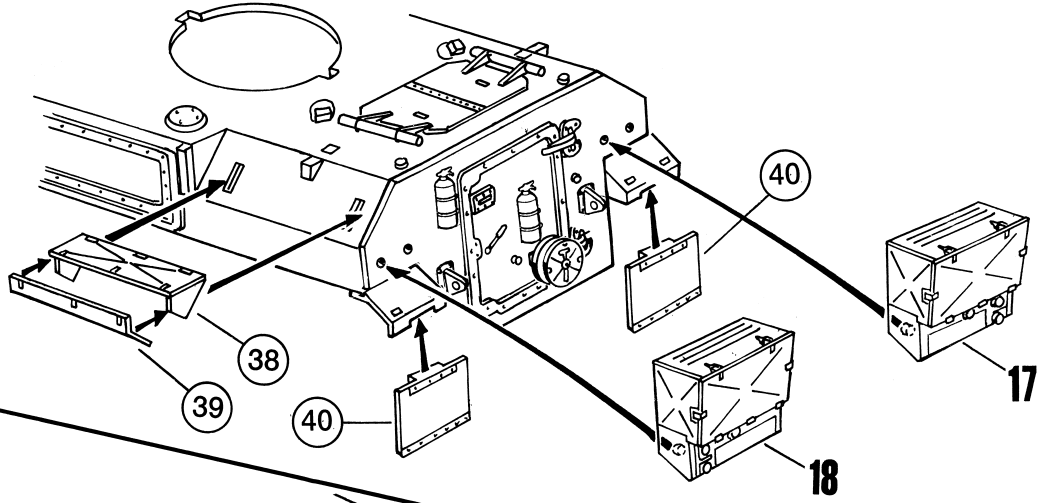

20 

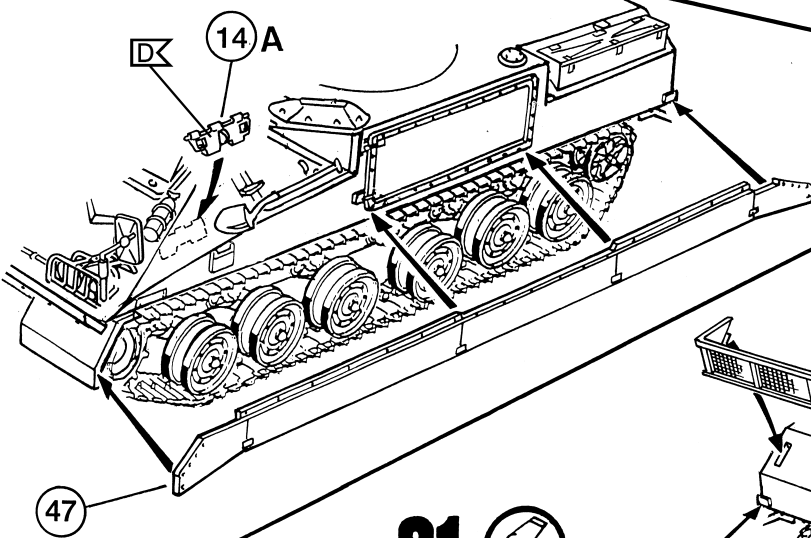

21 

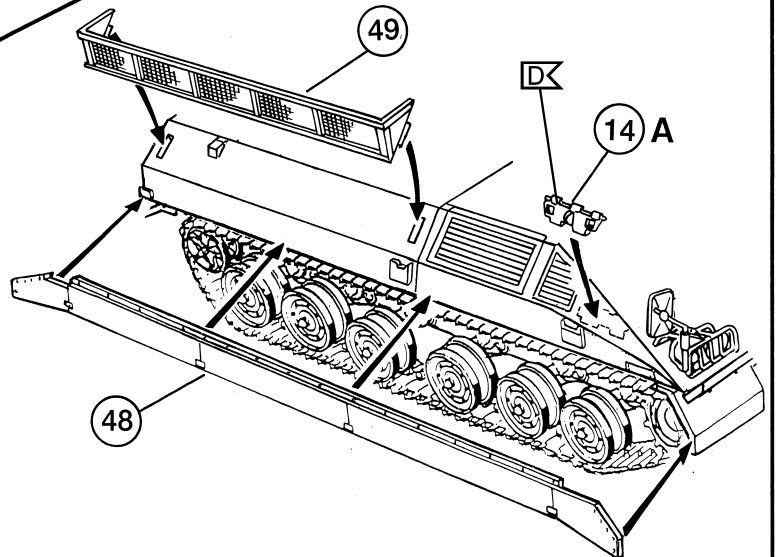

22 

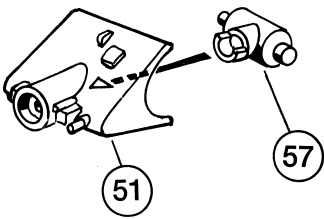

23 

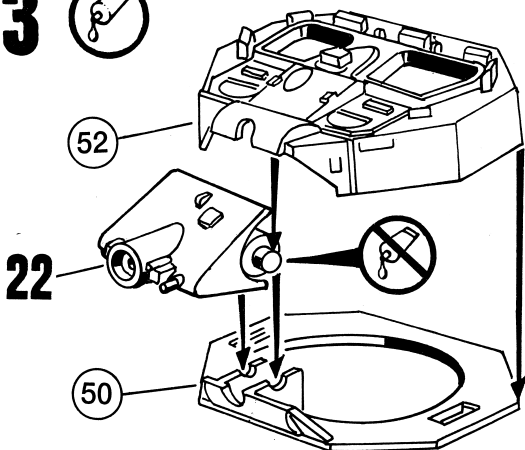

24 

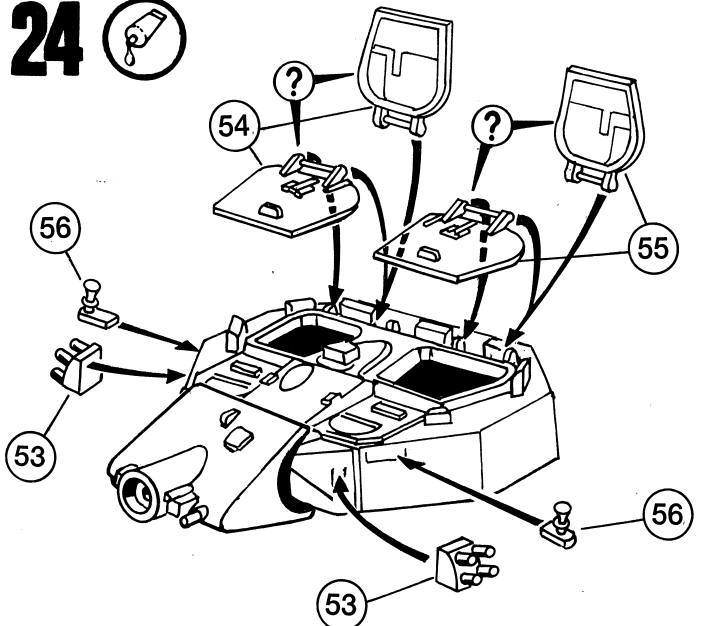

25

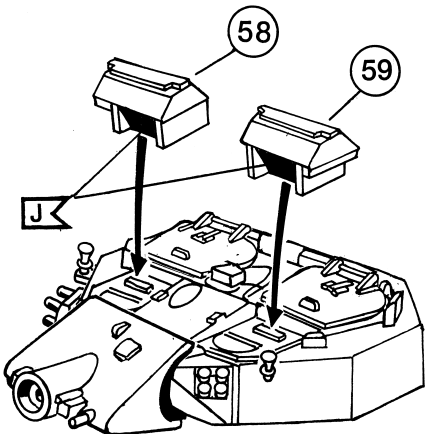

26

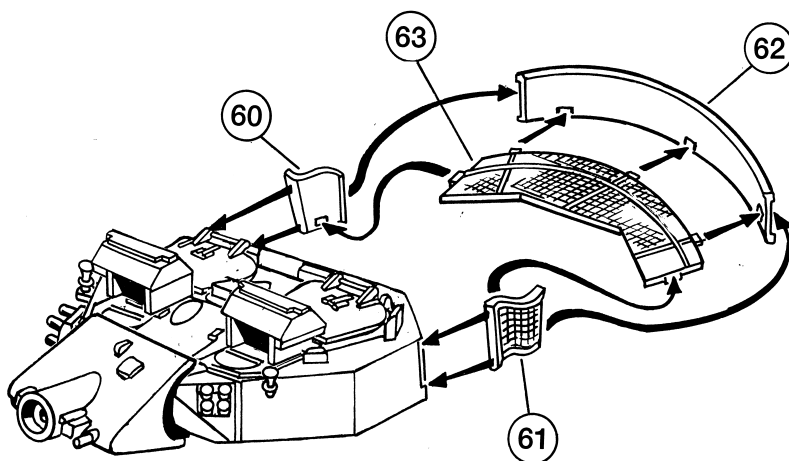

27

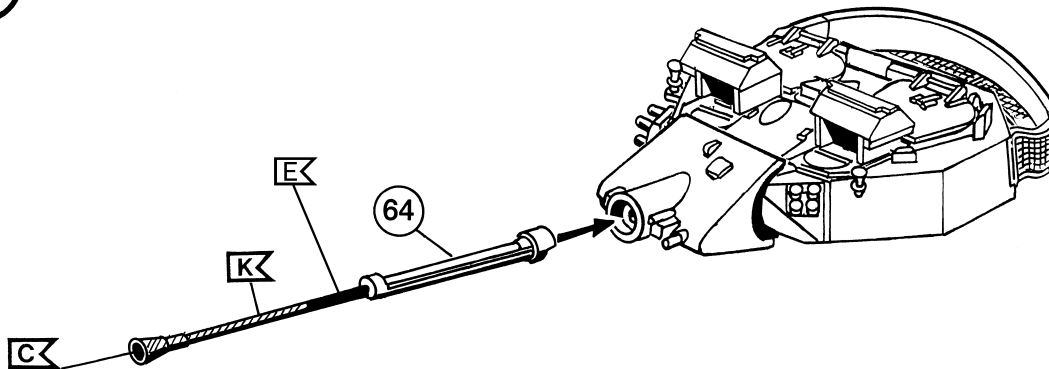

28

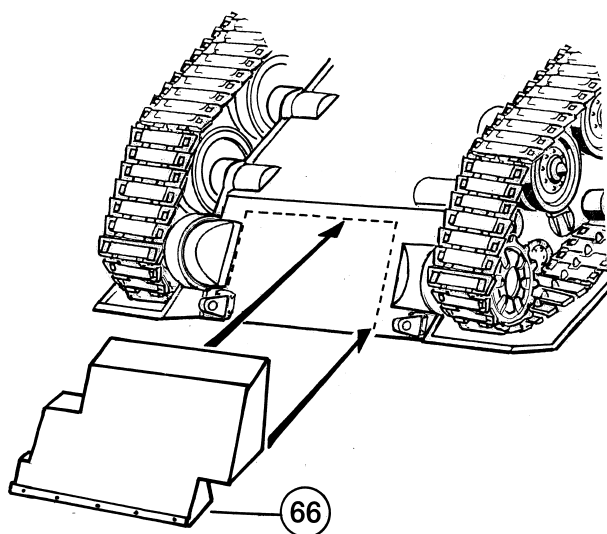

29

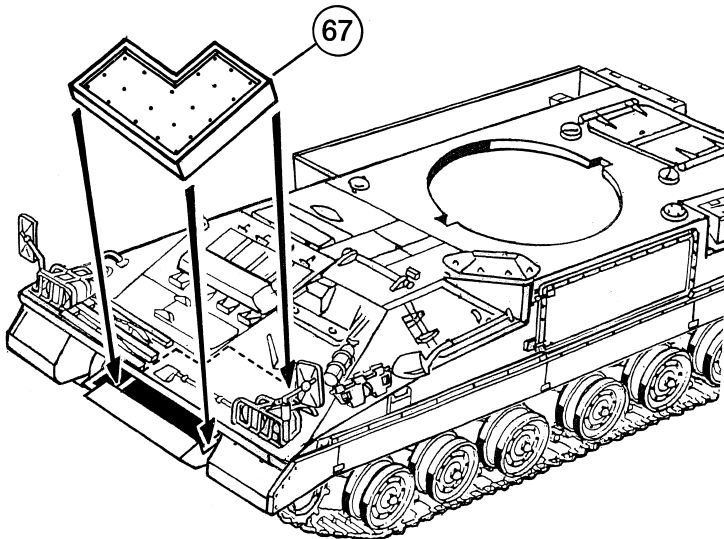

30

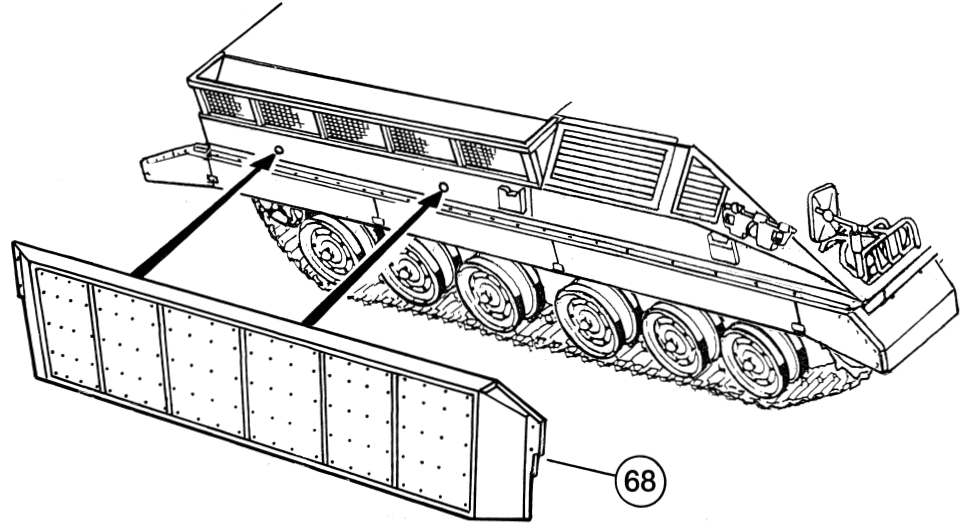

68

31

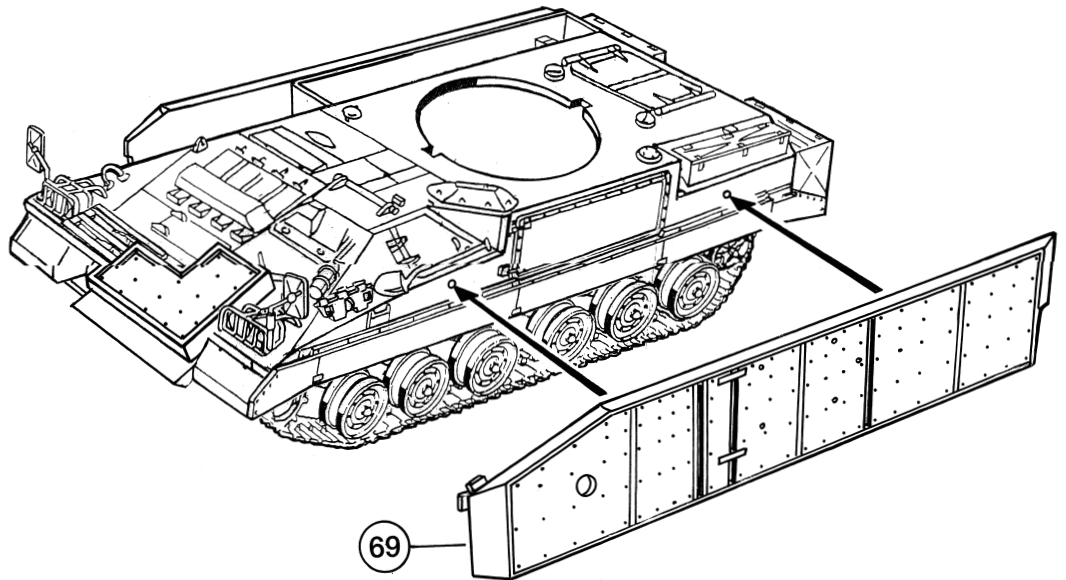

69

32

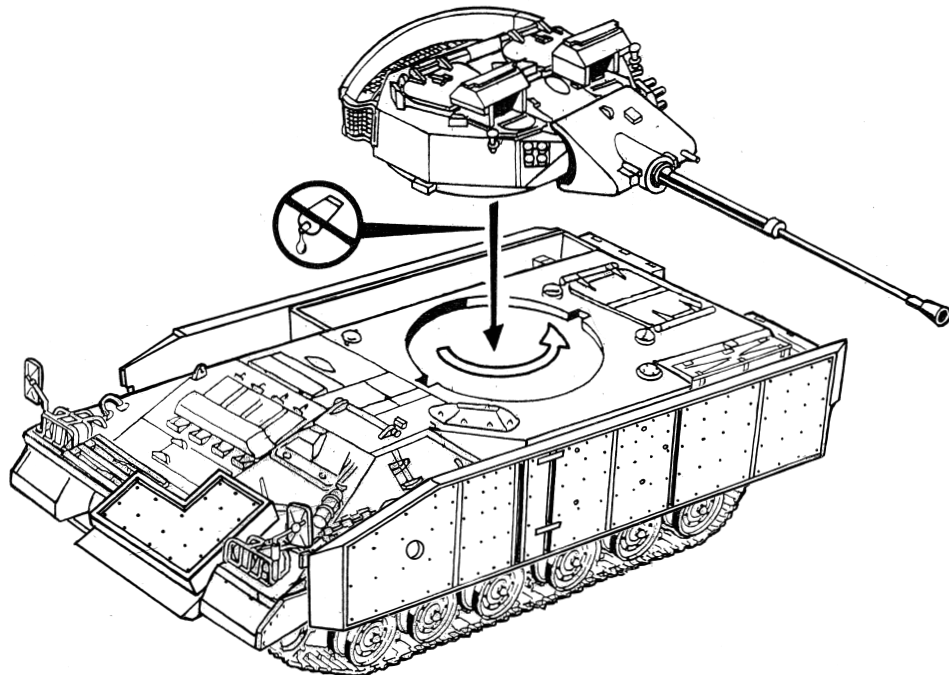

33



B-Company, 1. BN, The Cheshire Regiment
UNPROFOR, Bosnia 1993

37KG90 32 32 32 32

UN UN UN UN

UN UN UN UN

13 13

03144-0240 Warrior MCV
Printed in Italy for Revell GmbH & Co. KG, D-32257 Bünde



BK

