

Revell

KIT 5615

85561500200

AC-47 VIET NAM GUNSHIP

The United States Air Force converted fifty-three C-47's for use as special gun-ships in the Vietnam War. They were AC-47D aircraft armed with three 7.63mm high speed mini-guns that could fire up to an incredible 6,000 rounds per minute. The AC-47D's typically carried about 16,500 rounds of ammunition plus 48 MK-24 MOD3 flares with brightness of 2 million candle-power and a 3 minute maximum burn duration to illuminate their intended target area.



Decal Markings included for AC-47D "Casper", 1969, 4th Special Operations Squadron, Lt "Spooky" Sental No. 43-49010, 432nd Spooky Detachment, 432nd Tactical Recon Wing, Udorn South Vietnam

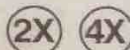

* REPEAT SEVERAL TIMES
* A REPETER PLUSIEURS FOIS



* OPTIONAL PARTS
* PIECES EN OPTION



* DECAL
* DECAL COMANE



* ALTERNATIVE ASSEMBLY
* ENSEMBLAGE ALTERNATIVE



* CEMENT TOGETHER
* A COLLER



* REMOVE AND THROW AWAY
* A RETIRER ET JETER



* DO NOT CEMENT
* NE PAS COLLER

READ THIS BEFORE YOU BEGIN

- * Study the assembly drawings.
- * Each plastic part is identified by a number.
- * In the assembly drawings, some parts will be marked by a star (★) to indicate chrome plated plastic.
- * For better paint and decal adhesion, wash the plastic parts in a mild detergent solution. Rinse and let air dry.
- * Check the fit of each piece before cementing in place.
- * Use only cement for polystyrene plastic.
- * Scrape plating and paint from areas to be cemented.
- * Allow paint to dry thoroughly before handling parts.
- * Any unused parts may be discarded.

DECAL APPLICATION INSTRUCTIONS

1. Cut desired decal from sheet.
2. Dip decal in water for a few seconds.
3. Place wet decal on paper towel.
4. Wait until decal is movable on paper backing.
5. Place decal in position on model, face up and slide backing away.
6. Press out air bubbles with a soft damp cloth.
7. Milkiness that may appear is for better decal adhesion and will dry clear. Wipe away any excess adhesive.
8. Do not touch decal until fully dry.
9. Allow the decals 48 hours to dry before applying clear coat.

NOTE: Decals are compatible with setting solutions or solvents.

LIRE CE QUI SUIV AVANT DE COMMENCER

- * Etudier les schémas de montage.
- * Chaque pièce en plastique est identifiée par un numéro.
- * Sur les schémas de montage, certaines pièces sont marquées d'une étoile (★) pour indiquer qu'elles sont en plastique chromé.
- * Pour une meilleure prise de la peinture et des autocollants, laver les pièces en plastique avec une solution détergente peu concentrée. Les rincer et les laisser sécher à l'air.
- * Vérifier que chaque pièce s'ajuste bien avant de la coller en place.
- * N'utiliser que de la colle pour polystyrène.
- * Gratter les parties à coller pour enlever le chrome et la peinture.
- * Laisser la peinture bien sécher avant de manipuler les pièces.
- * Toute pièce inutilisée peut être jetée.

DIRECTIVES D'APPLICATION DES AUTOCOLLANTS

1. Découper l'autocollant désiré de la feuille.
2. Tremper l'autocollant dans de l'eau pendant quelques secondes.
3. Placer l'autocollant mouillé sur une serviette en papier.
4. Attendez que l'autocollant puisse être déplacé sur son support en papier.
5. Mettre l'autocollant en position sur le modèle face sur le dessus et faire glisser le support pour l'enlever.
6. Appuyer avec un chiffon doux humide pour éliminer les bulles d'air.
7. La substance laiteuse qui peut apparaître est destinée à améliorer l'adhésion de l'autocollant et devient incolore au séchage. Essuyer pour enlever tout excédent d'adhésif.
8. Ne pas toucher l'autocollant tant qu'il n'est pas bien sec.
9. Laisser l'autocollant sécher pendant 48 heures avant d'appliquer une couche transparente.

REMARQUE: Les autocollants sont compatibles avec les solutions de fixation ou les solvants.

This paint guide is provided to complete this kit as shown on the box.

Ce guide de peintures est fourni pour reproduire le modèle réduit qui apparaît sur la boîte.

Interior Green	Interior vert
Flat Black	Noir terre
Black	Noir
White	blanc
Silver	Argent
Brown	Brun
Tan	Brun clair
Olive Drab	Vert Olive
Light Gray	gris clair
Dark Green	Vert foncé
Yellow	Jaune
Red	Rouge
Brass	Laiton

If you have any questions or comments, call our hotline at: **(800) 833-3570**
or, please write to:

Revell Inc Consumer Service Department, 1850 Howard Street Unit A, Elk Grove Village, Illinois 60007
Be sure to include the plan number (85561500200), part number, description, your return address and phone number.

Visit our website: www.revell.com

1

COCKPIT / RADIO ROOM ASSEMBLY

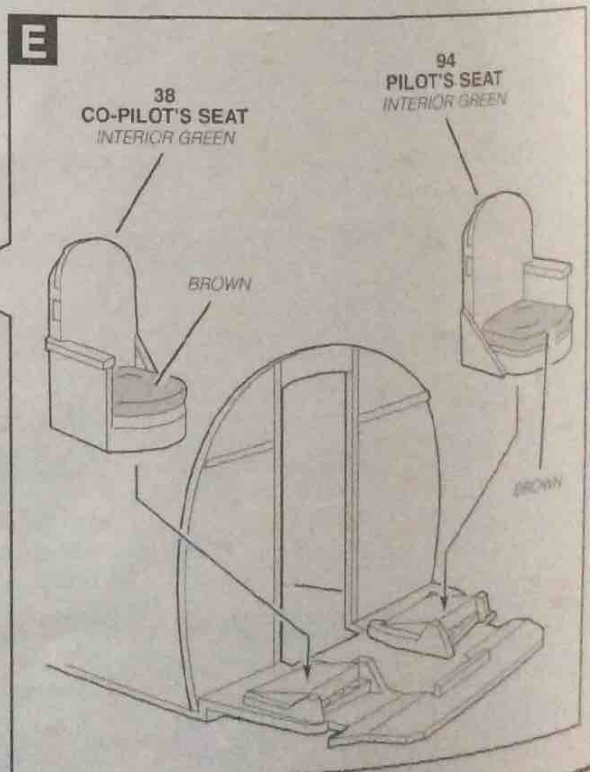
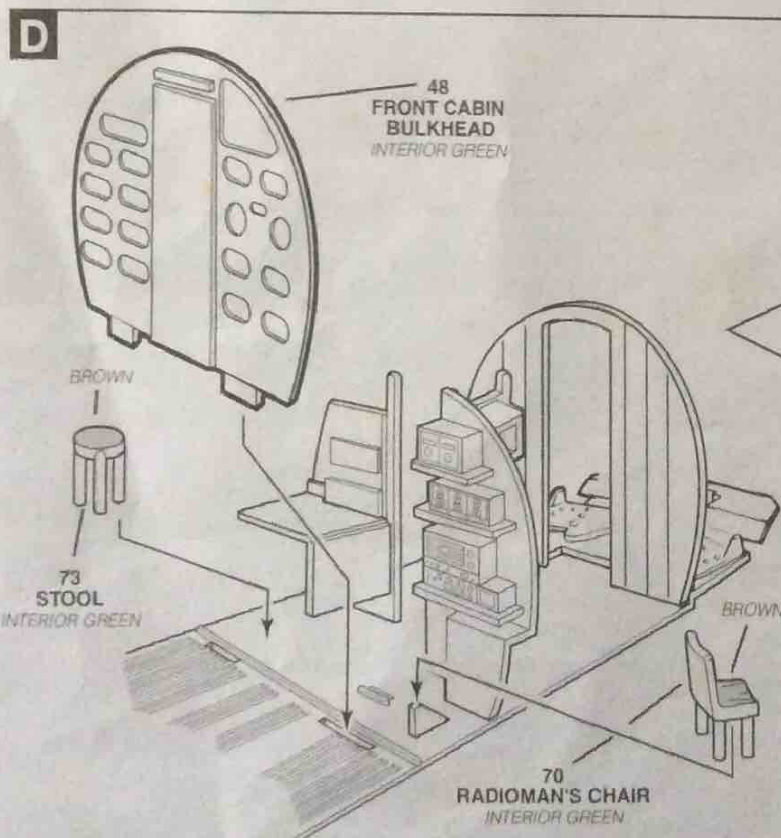
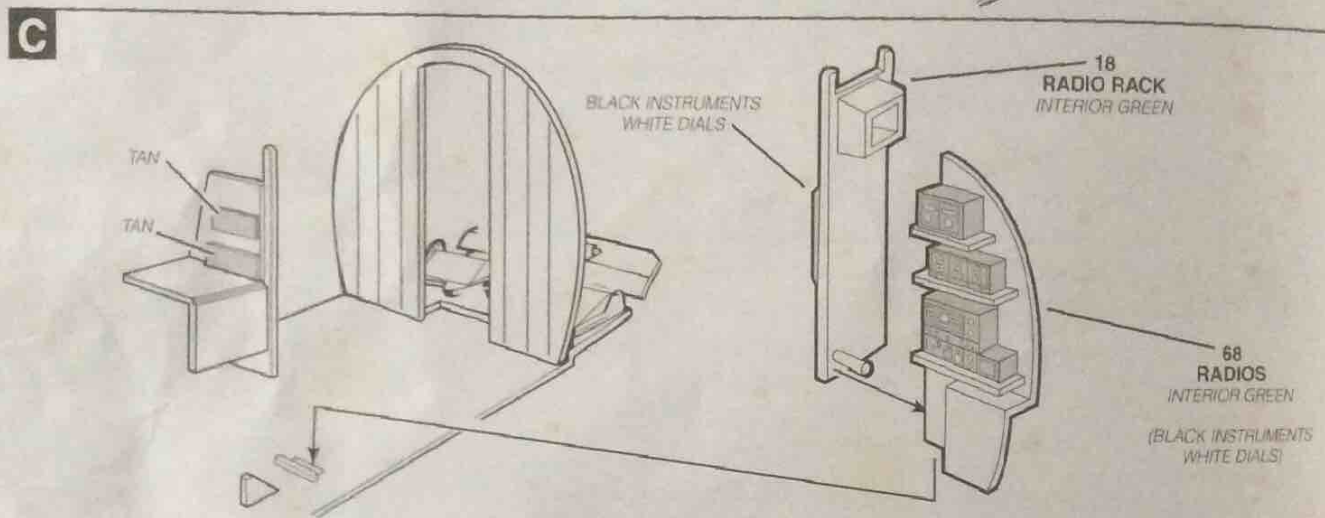
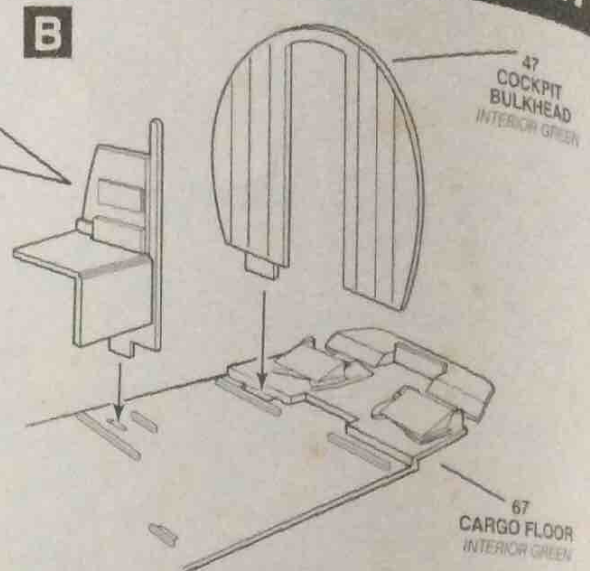
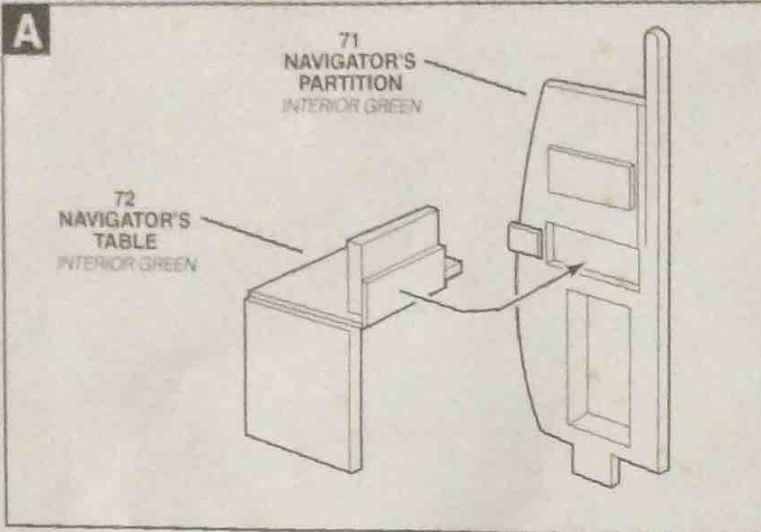

1

COCKPIT ASSEMBLY CONTINUED

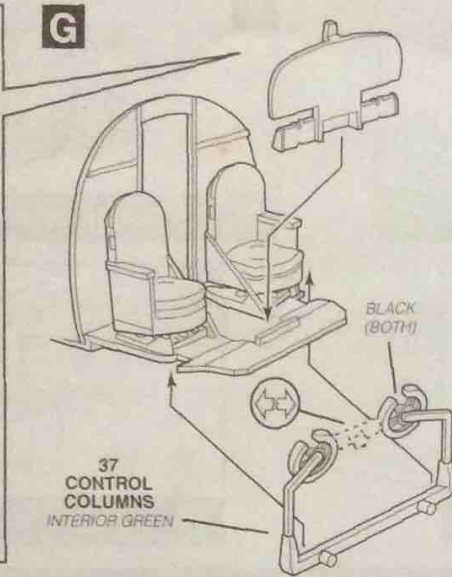
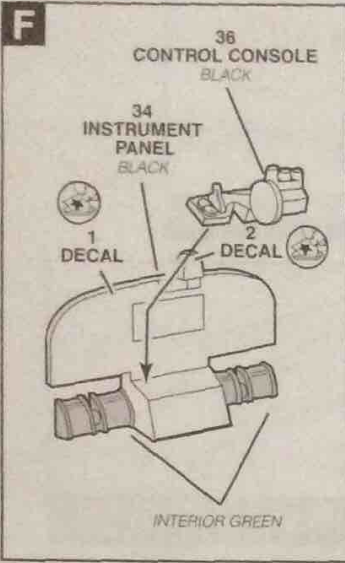

REAR BULKHEAD

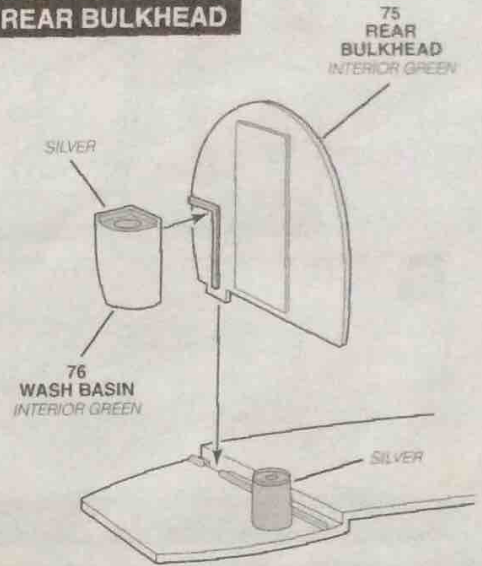

2

RIGHT FUSELAGE WINDOW ASSEMBLY

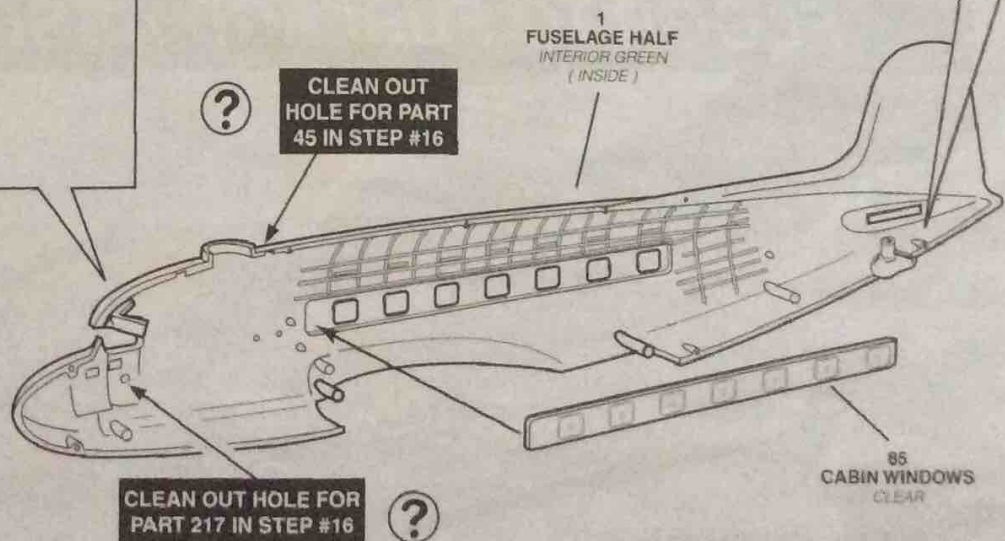
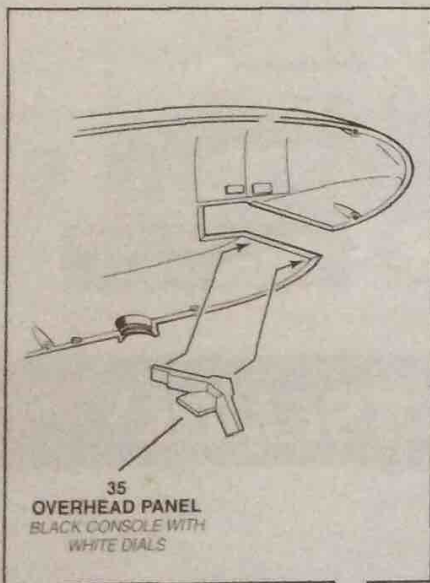

3 LEFT FUSELAGE CARGO DOOR ASSEMBLY

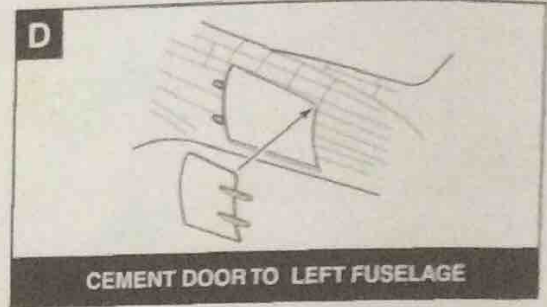
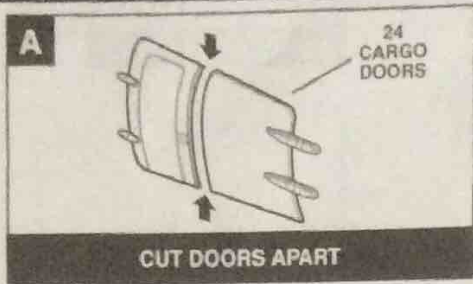

4 LEFT WINDOW / SIGHT ASSEMBLY



5 FLOOR TO FUSLAGE ASSEMBLY

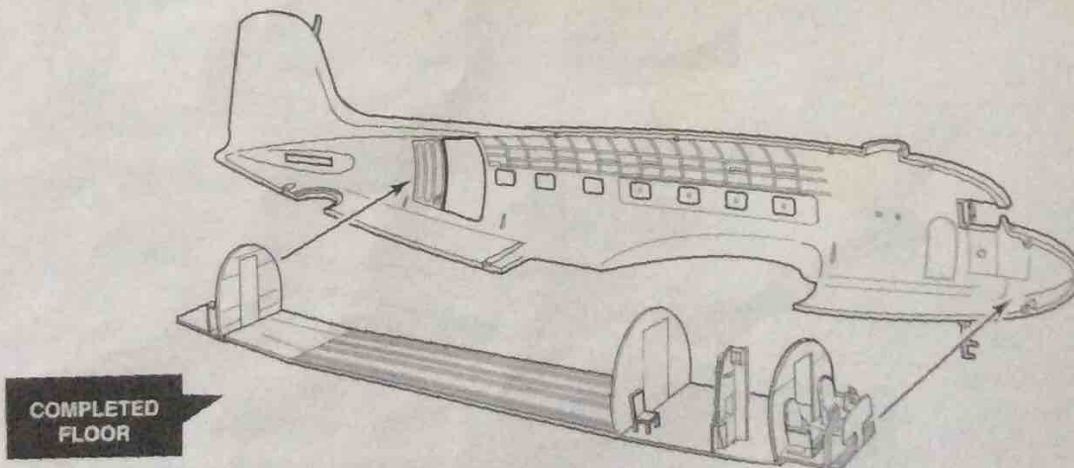

6

LEFT SIDE GUN / SEAT ASSEMBLY

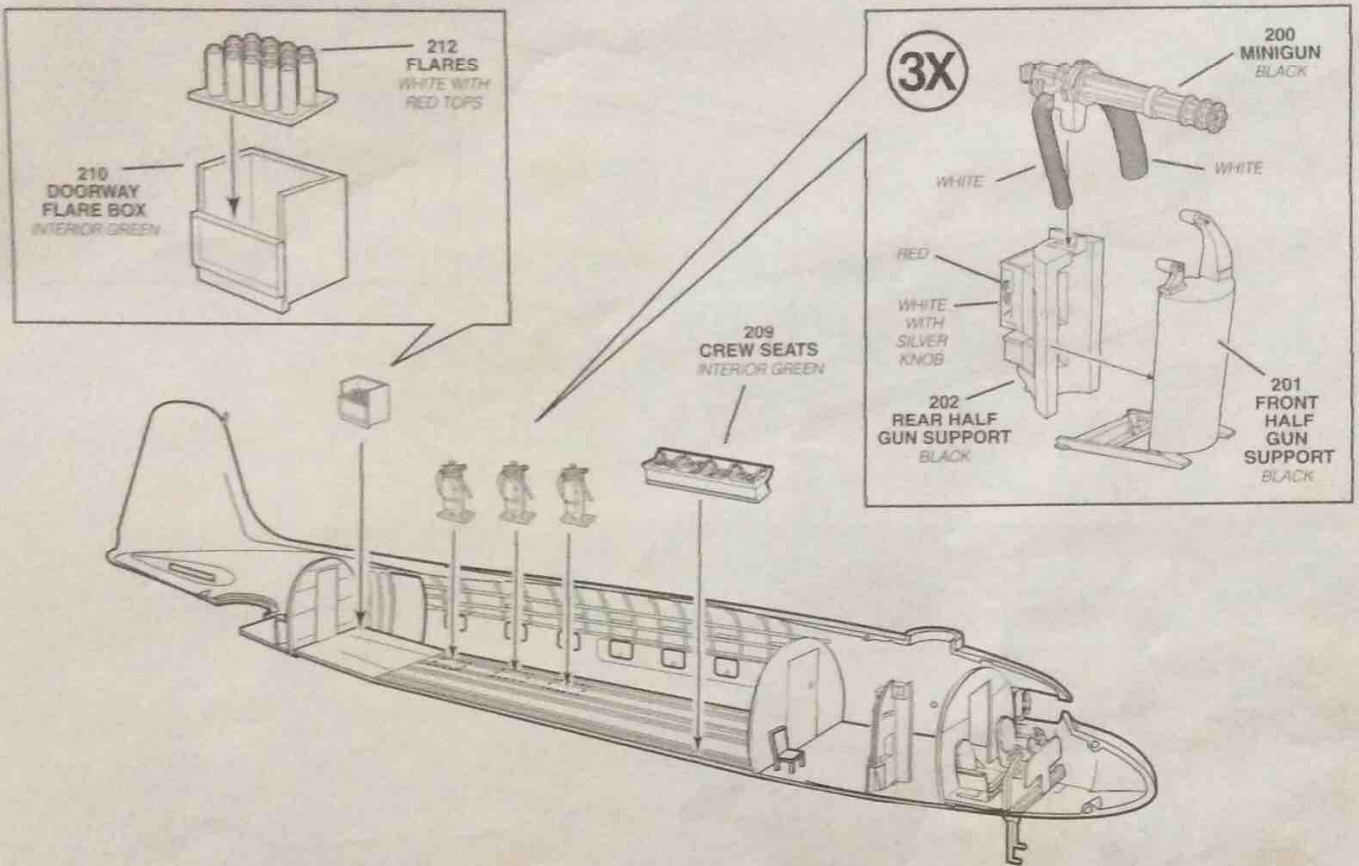

7

LEFT FUSELAGE BLANKET ASSEMBLY

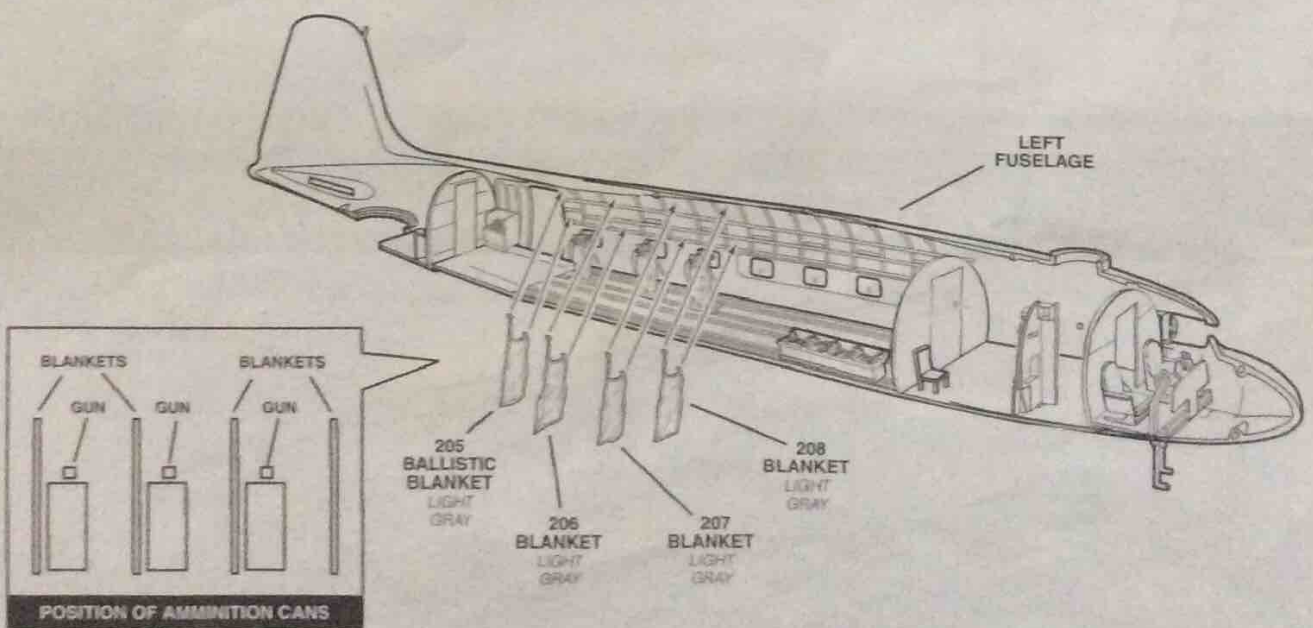

9

WING ASSEMBLY CONTINUED

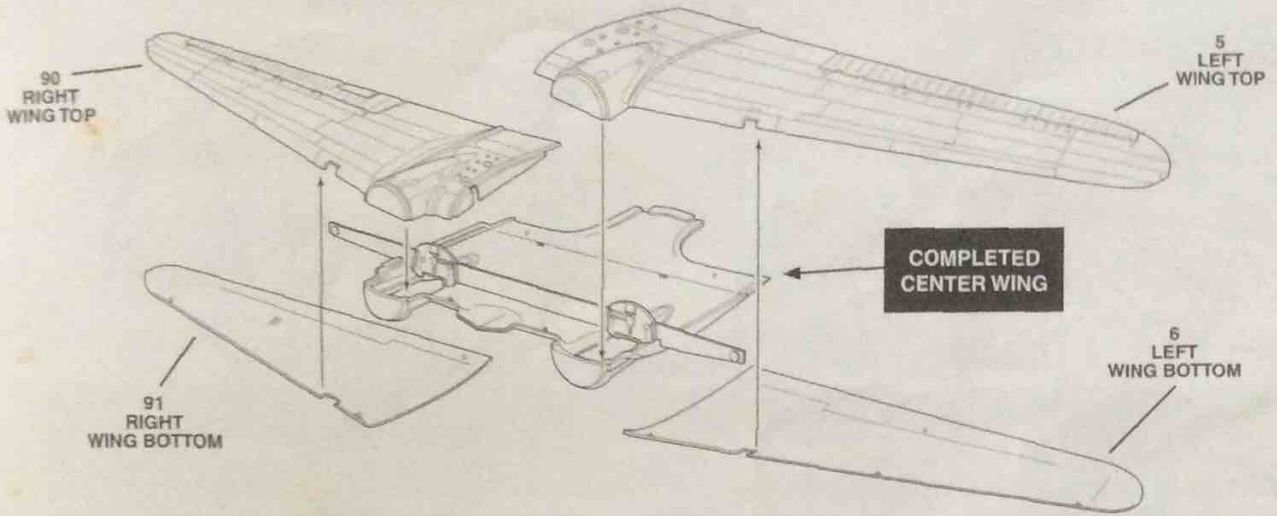

10

COWLING / LIGHTS ASSEMBLY

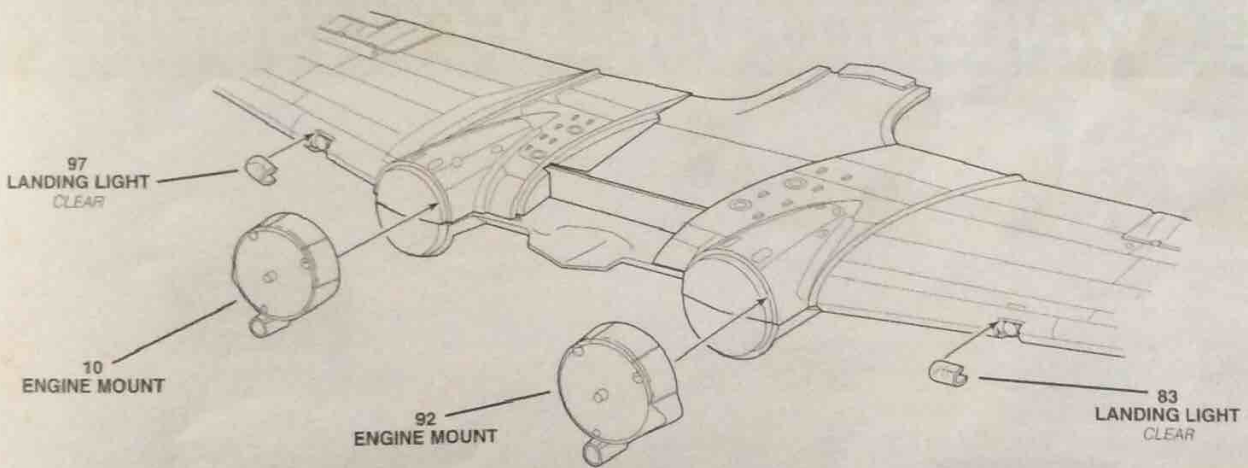

11

LANDING GEAR ASSEMBLY

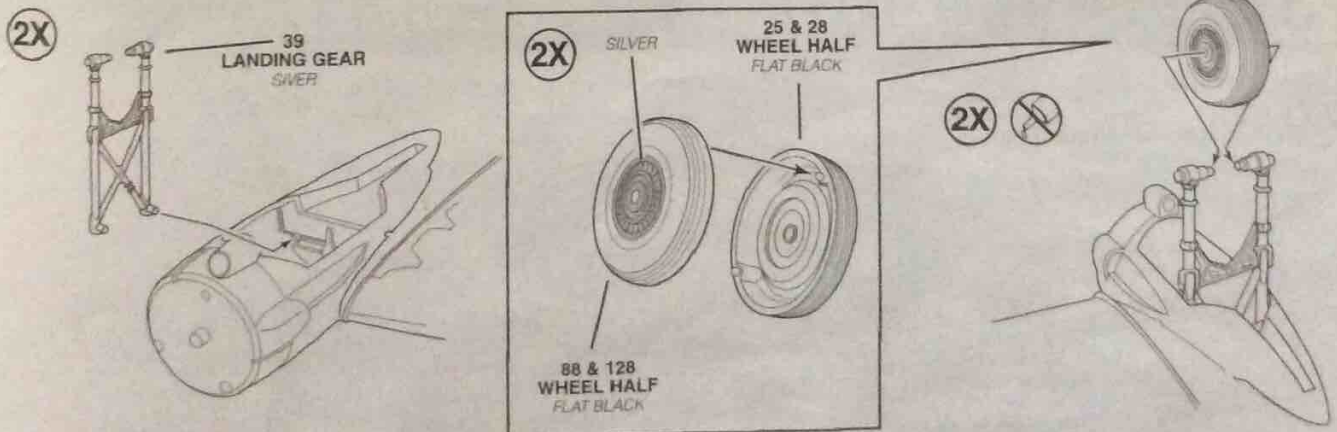

11 LANDING GEAR ASSEMBLY CONTINUED

2X

42
DRAG STRUT
SILVER

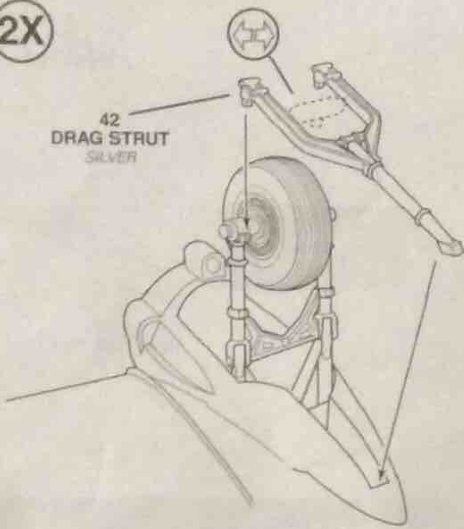

2X

40
GEAR LINK
SILVER

40
GEAR LINK
SILVER

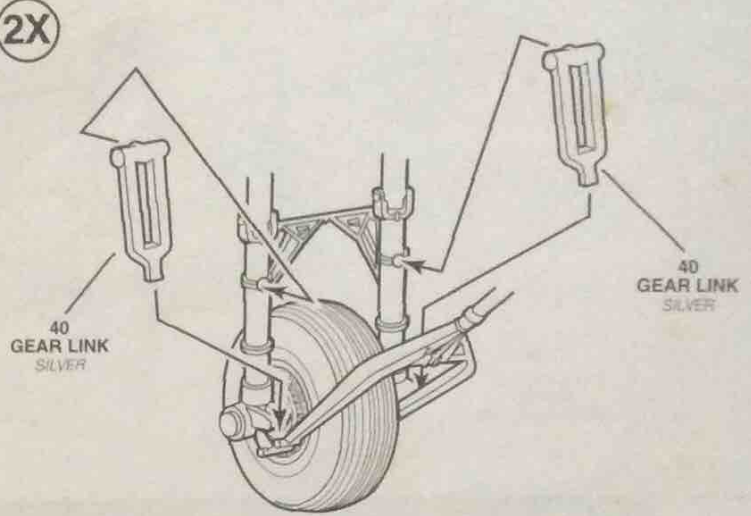

12 WINGS TO FUSELAGE ASSEMBLY

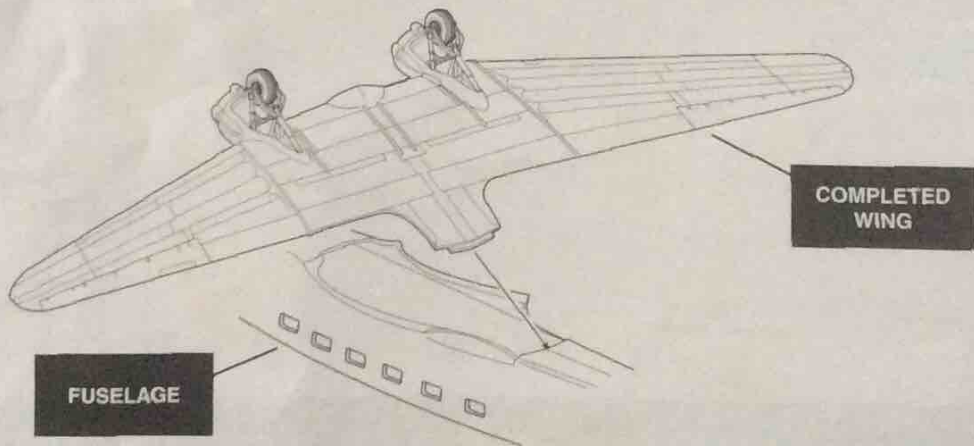

13 ENGINE ASSEMBLY

2X

49
PROPELLER PIN
INTERIOR GREEN

32
ENGINE
INTERIOR GREEN

SILVER

INTERIOR GREEN

YELLOW

11
ENGINE COWLING

SILVER

216
PROPELLER
FLAT BLACK

YELLOW

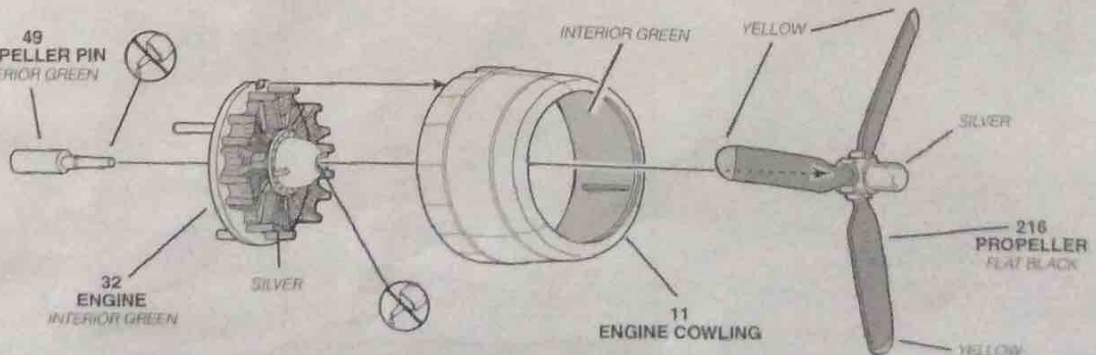

14

ENGINES TO COWLING ASSEMBLY

RIGHT

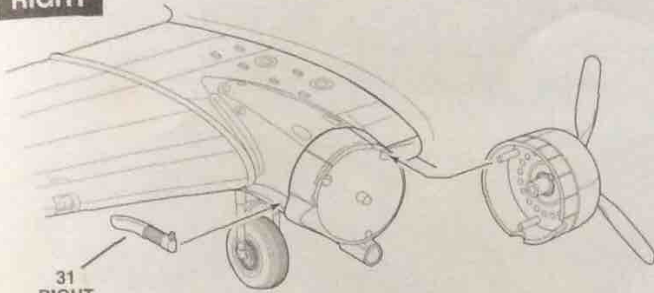

31
RIGHT
EXHAUST
SILVER

LEFT

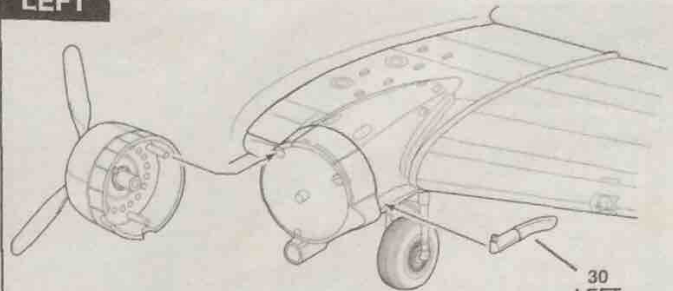

30
LEFT
EXHAUST
SILVER

15

STABLIZER ASSEMBLY

LEFT

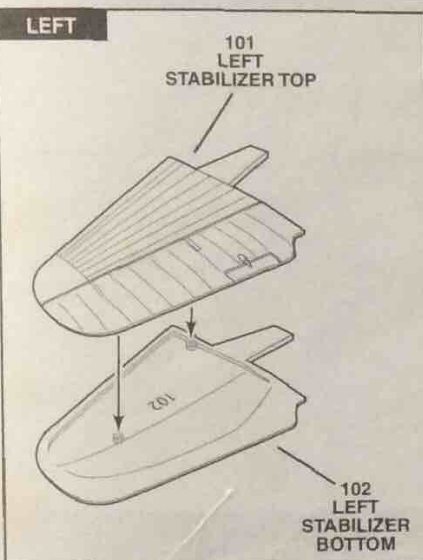

101
LEFT
STABILIZER
TOP

102
LEFT
STABILIZER
BOTTOM

RIGHT

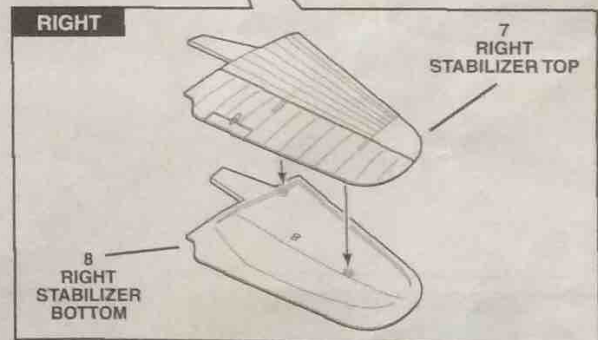

7
RIGHT
STABILIZER
TOP

8
RIGHT
STABILIZER
BOTTOM

16

FILTER / ANTENNA / VENTURE ASSEMBLY

2X

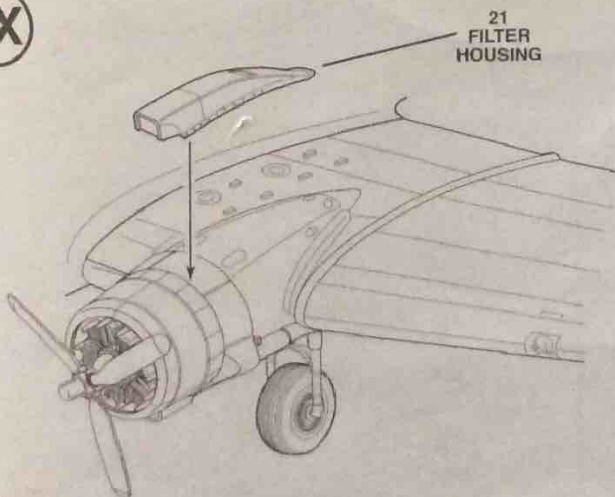

21
FILTER
HOUSING

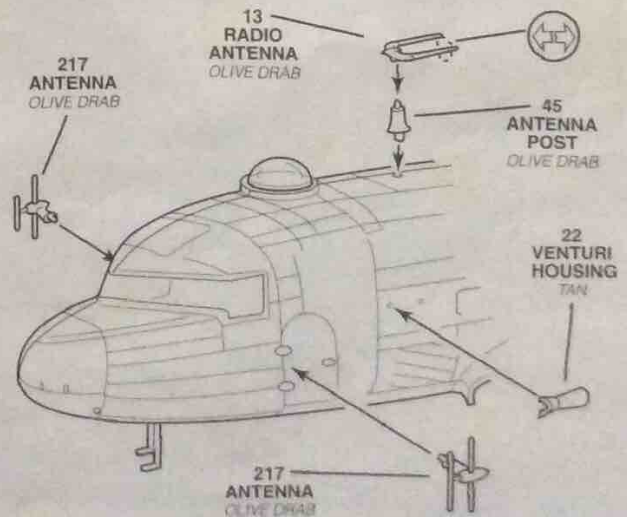

13
RADIO
ANTENNA
OLIVE DRAB

217
ANTENNA
OLIVE DRAB

45
ANTENNA
POST
OLIVE DRAB

22
VENTURI
HOUSING
TAN

217
ANTENNA
OLIVE DRAB

17

WINDSHIELD / ANTENNA ASSEMBLY

NOTE:
LIGHTLY SQUEEZE BOTH
ENDS OF WINDSHIELD TO
FIT IN POSITION

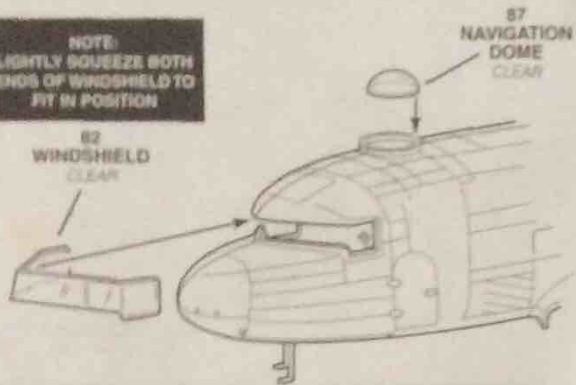

9 DIRECTIONAL ANTENNA BLACK

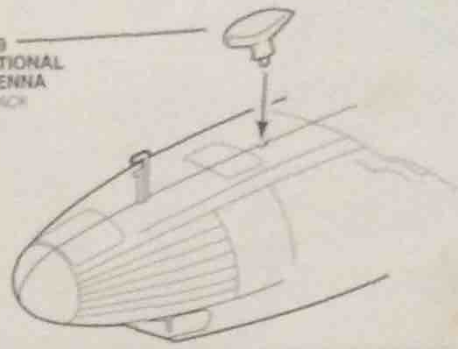

18

TAIL WHEEL ASSEMBLY

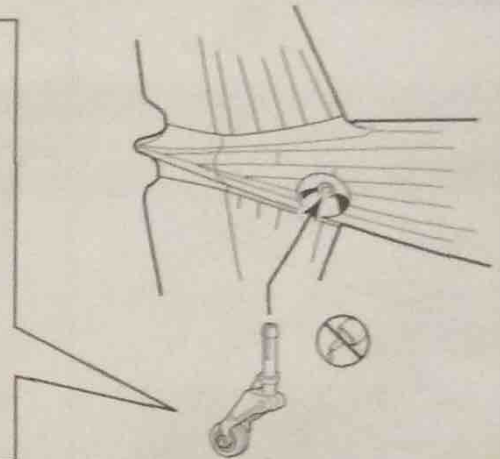
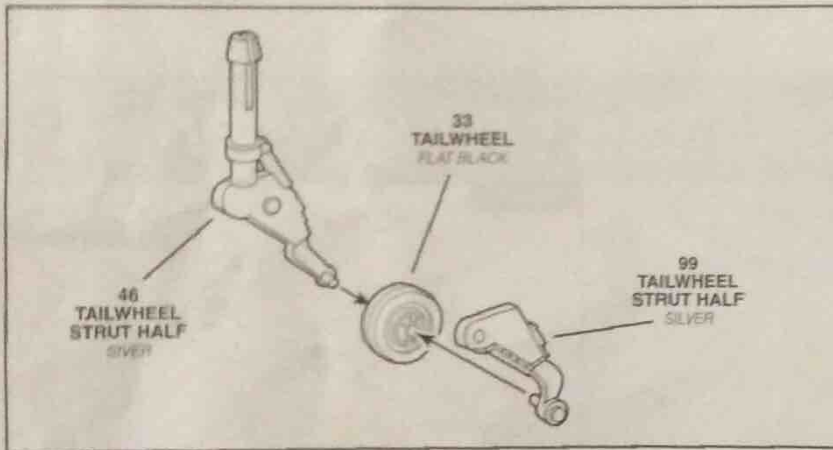

19

FINAL ASSEMBLY

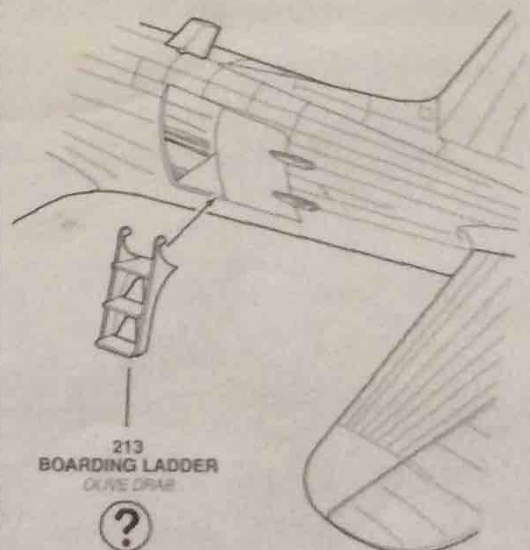
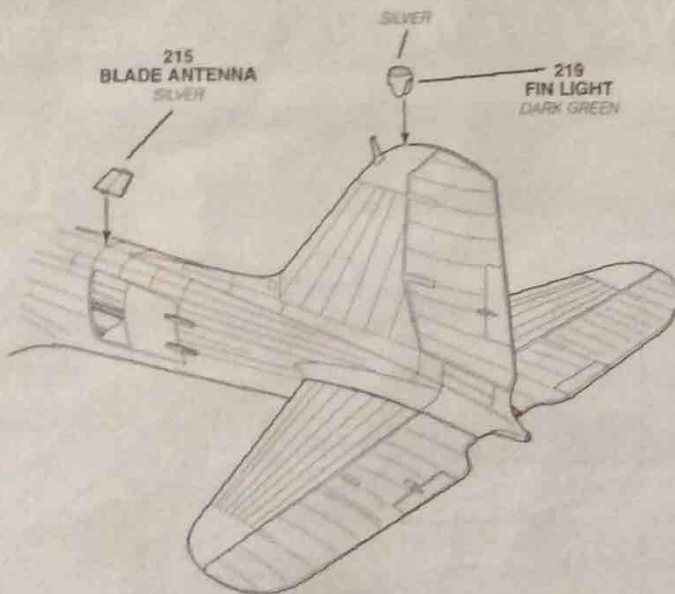

DECAL PLACEMENT

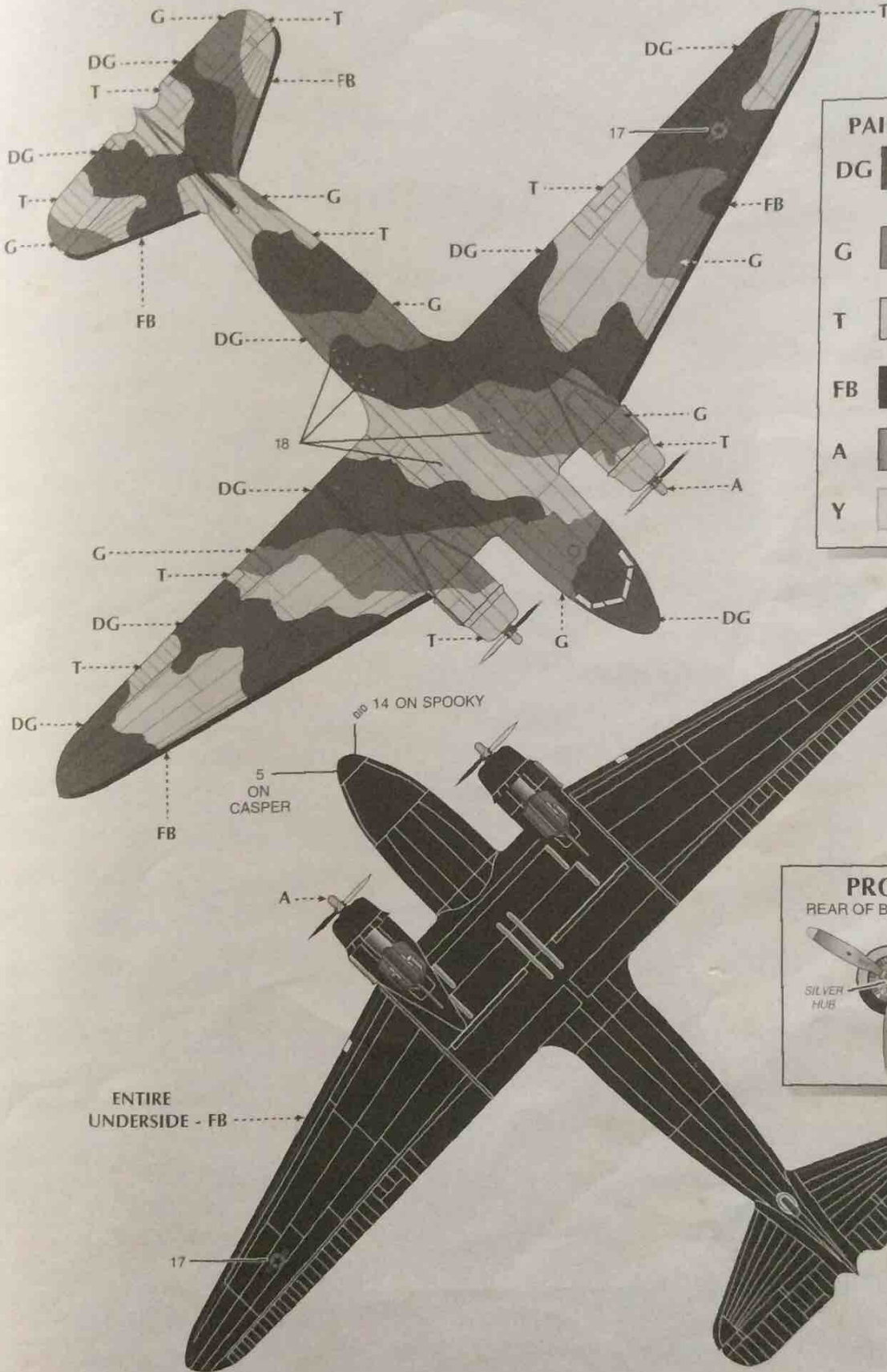

PAINT COLORS	
DG	DARK GREEN FS 34079
G	OLIVE DRAB FS 34102
T	TAN FS30219
FB	FLAT BLACK FS30219
A	SILVER
Y	YELLOW FS13538

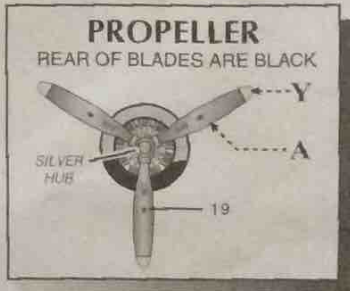

ENTIRE
UNDERSIDE - FB

5 ON CASPER
14 ON SPOOKY